



PO Box 449  
Pewaukee, WI 53072  
www.pdhacademy.com  
888-564-9098



AIA Provider #50119838

## **Florida Building Code, Building, 5<sup>th</sup> Edition 2014: Highlights and Changes Advanced Course**

*Steve Preins, BSCM, Florida International University  
Florida approved instructor for Inspection Certification Associates*

This 2 CE hour Florida Advanced Building Code Course discusses some of the many highlights and changes from the previous code (2010) and focuses only on Chapters 1 to 16 of the 2014 Building Code. It is presented in accordance with the requirements of the Florida Department of Business and Professional Regulation (DBPR) for the required Advanced Florida Building Code Module. It also complies with the AIA requirement of a minimum of 5000 words per hour.

The Florida Building Code, Building, 5th Edition 2014 replaced the 2010 Florida Building Code as of June 30, 2015. Based on the 2012 editions of various International Code Council codes, the 2014 FBC includes numerous changes to the previous Code, including Florida specific amendments to the IBC base code.

One of the most visible changes from the 2010 codes is the reformatting of the Energy Code, which now consists of two independent sub-documents: one for low-rise residential and one for commercial or high-rise residential. The Florida Building Commission also expanded options for compliance methods for commercial and high-rise residential buildings to including the allowance of American Society of Heating, Refrigerating and Air Conditioning Engineers, Inc. (ASHRAE) 90.1.

This course presents only a few of the many important changes from the 2010 Florida Building Code and from the 2012 International Building Code (the base code). While we have tried to include many of the significant changes, each building professional will have their own specialties and areas of expertise, making it incumbent on every Florida architect to carefully study the code sections that most affect their professional practice.

### **Chapter 1, Scope and Administration: *Significant Changes***

#### **102.4 REFERENCED CODES AND STANDARDS**

This section was split into two sections for clarity and for coordination with new Section 102.4.2. The 2010 Section 102.4 remains as Referenced codes and standards while added Section 102.4.1 is Conflicts.

New section 102.4.2 expands upon the requirements in Section 102.4.1 by making it clear that, even if a referenced standard contains requirements that parallel the Florida Building Code Building (FBCB), the provisions of the FBCB will always take precedence.

**From 2014 FBC Building:**

**[A] 102.4 Referenced codes and standards.** The codes and standards referenced in this code shall be considered part of the requirements of this code to the prescribed extent of each such reference and as further regulated in Sections 102.4.1 and 102.4.2.

**[A] 102.4.1 Conflicts.** Where ~~differences~~ conflicts occur between provisions of this code and referenced codes and standards, the provisions of this code shall apply.

**[A] 102.4.2 Provisions in referenced codes and standards.** Where the extent of the reference to a referenced code or standard includes subject matter that is within the scope of this code or the Florida Codes listed in Section 101.4, the provisions of this code or the Florida Codes listed in Section 101.4, as applicable, shall take precedence over the provisions in the referenced code or standard.

A new section was added permitting site plans to be maintained in the form of an electronic copy at the worksite.

**From 2014 FBC Building:**

**107.2.5.2**

For the purpose of inspection and record retention, site plans for a building may be maintained in the form of an electronic copy at the worksite. These plans must be open to inspection by the building official or a duly authorized representative, as required by the Florida Building Code.

**Chapter 2, Definitions: *Significant Changes***

**202 DEFINITIONS**

Many terms have typically been defined to clarify their meaning within the context of the code. Previously, these definitions were located throughout their respective code sections. In order to make the definitions easier to locate, most have been moved to Chapter 2, Definitions. However, some definitions are still located in the various code sections. Additionally, some definitions have been added, deleted or modified.

**From 2014 FBC Building:**

**24 HOUR CARE.** The actual time that a person is an occupant within a facility for the purpose of receiving care. It shall not include a facility that is open for 24 hours and is capable of providing care to someone visiting the facility during any segment of the 24 hours.

**AMBULATORY CARE FACILITY.** Buildings or portions thereof used to provide medical, surgical, psychiatric, nursing or similar care on a less than 24-hour basis to persons who are rendered *incapable of self-preservation* by the services provided.

**CONGREGATE LIVING FACILITIES.** A building or part thereof that contains sleeping units where residents share bathroom and/or kitchen facilities

**CUSTODIAL CARE.** Assistance with day-to-day living tasks; such as assistance with cooking, taking medication, bathing, using toilet facilities, and other tasks of daily living. Custodial care include occupants who evacuate at a slower rate and/or who have mental and psychiatric complications.

**DETOXIFICATION FACILITIES.** Facilities that serve patients who are provided treatment for substance abuse ~~on a 24-hour basis and~~ serving care recipients who are incapable of self-preservation or who are harmful to themselves or others.

**EXIT.** That portion of a means of egress system ~~which is separated from other interior spaces of a building or structure by fire resistance rated construction and opening protective as required to provide a protected path of egress travel~~ between the exit access and the exit discharge or public way. Exit components include exterior exit doors at the level of exit discharge, interior exit stairways, interior exit ramps, exit passageways, exterior exit stairways, and exterior exit ramps and horizontal exit.

**EXIT ACCESS DOORWAY.** A door or access point along the path of egress travel from an occupied room, area or space where the path of egress enters an intervening room, corridor, ~~unenclosed exit access stair~~ or ~~unenclosed exit access ramp~~.

**EXIT ACCESS RAMP.** An interior ramp that is not a required interior exit ramp.

**EXIT ACCESS STAIRWAY.** An interior stairway that is not a required interior exit stairway.

**EXIT ENCLOSURE.** An exit component that is separated from other interior spaces of a building or structure by fire resistance rated construction and opening protectives, and provides for a protected path of egress travel in a vertical or horizontal direction to the exit discharge or the public way.

*The following two definitions were combined for clarity:*

**FIBER REINFORCED POLYMER.** A polymeric composite material consisting of reinforcement fibers, such as glass, impregnated with a fiberbinding polymer which is then molded and hardened. Fiber-reinforced polymers are permitted to contain cores laminated between fiber-reinforced polymer facings.

**FIBERGLASS REINFORCED POLYMER.** Polymeric composite material consisting of glass reinforcement fibers impregnated with a fiber binding polymer which is then molded and hardened.

**FIRE-RATED GLAZING.** Glazing with either a fire protection rating or a fire resistance rating.

**FOSTER CARE FACILITIES.** Facilities that provide care to more than five children, 2½ years of age or less.

**FLY GALLERY.** A raised floor area above a stage from which the movement of scenery and operation of other stage effects are controlled.

**GAS CABINET.** A fully enclosed, ventilated noncombustible enclosure used to provide an isolated environment for *compressed gas* cylinders in storage or use. Doors and access ports for exchanging cylinders and accessing pressure-regulating controls are allowed to be included.

**GRIDIRON.** The structural framing over a stage supporting equipment for hanging or flying scenery and other stage effects.

**HELIPAD.** A structural surface that is used for the landing, taking off, taxiing, and parking of helicopters.

**HOSPITALS AND MENTAL PSYCHIATRIC HOSPITALS.** ~~Facilities buildings, or portions thereof used on a 24-hour basis~~ that provide care or treatment for the medical, psychiatric, obstetrical, or surgical treatment of ~~inpatients who~~ care recipients that are incapable of self-preservation.

**HURRICANE-PRONE REGIONS.** Areas vulnerable to hurricanes defined as:

1. The U. S. Atlantic Ocean and Gulf of Mexico coasts where the ~~basic wind speed~~ ultimate design wind speed,  $V_{ult}$ , for Risk Category II buildings is greater than 115 mph (51.4 m/s) ~~(40 m/s)~~ and
2. Hawaii, Puerto Rico, Guam, Virgin Islands and American Samoa

**ICE-SENSITIVE STRUCTURE .** A structure for which the effect of an atmospheric ice load governs the design of a structure or portion thereof. This includes, but is not limited to, lattice structures, guyed masts, overhead lines, light suspension and cable-stayed bridges, aerial cable systems (e.g., for ski lifts or logging operations), amusement rides, open catwalks and platforms, flagpoles and signs.

**Related 1602 Definitions and Notations**

$D_i$  = Weight of ice in accordance with Chapter 10 of ASCE 7.

$W_i$  = Wind-on-ice in accordance with Chapter 10 of ASCE 7.

**INCAPABLE OF SELF PRESERVATION.** Persons because of age; physical limitations; mental limitations; chemical dependency, or medical treatment who cannot

respond as an individual to an emergency situation.

**INTERIOR EXIT RAMP.** An exit component that serves to meet one or more means of egress design requirements, such as required number of exits or exit access travel distance, and provides for a protected path of egress travel to the exit discharge or public way.

**INTERIOR EXIT STAIRWAY.** An exit component that serves to meet one or more means of egress design requirements, such as required number of exits or exit access travel distance, and provides for a protected path of egress travel to the exit discharge or public way.

**L RATING.** The air leakage rating of a through-penetration firestop system or a fire-resistant joint system when tested in accordance with UL 1479 or UL 2079, respectively.

**LIVE/WORK UNIT.** A dwelling unit or sleeping unit in which a significant portion of the space includes a nonresidential use that is operated by the tenant.

**MECHANICAL EQUIPMENT SCREEN.** A partially enclosed rooftop structure, used to aesthetically conceal heating, ventilating and air conditioning (HVAC) electrical or mechanical equipment from view.

**MEDICAL CARE.** Care involving medical or surgical procedures, nursing, or for psychiatric purposes.

**NURSING HOMES.** Nursing homes are long-term care Facilities that provide care on a 24-hour basis, including both intermediate care facilities and skilled nursing facilities, serving more than five persons where any of the persons are incapable of self-preservation.

**PHOTOVOLTAIC MODULES/SHINGLES.** A roof covering composed of flat-plate photovoltaic modules fabricated in sheets that resemble three tab composite shingles.

**PINRAIL.** A rail on or above a stage through which belaying pins are inserted and to which lines are fastened.

**POLYPROPYLENE SIDING.** A shaped material, made principally from polypropylene homopolymer, or copolymer, which in some cases contain fillers or reinforcements, that is used to clad exterior walls of buildings.

**SUSCEPTIBLE BAY.** A roof, or portion thereof, with: (1) A slope less than ¼ inch per foot (0.0208 rad) or (2) On which water is impounded upon it, in whole or in part, and the secondary drainage system is functional but the primary drainage system is blocked. A roof surface with a slope of ¼ inch per foot (0.0208 rad) or greater toward points of free drainage is not a susceptible bay.

**TECHNICAL PRODUCTION AREA.** Open elevated areas or spaces intended for entertainment technicians to walk on and occupy for servicing and operating entertainment technology systems and equipment. Galleries, including fly and lighting galleries, gridirons, catwalks, and similar areas are designed for these purposes.  
**WIND-BORNE DEBRIS REGION.** Areas within portions of hurricane prone regions located:

1. Within 1 mile (1.61 km) of the coastal mean high water line where the ultimate design wind speed,  $V_{ult}$ , is 130 mph (58 m/s) (~~48 m/s~~) or greater; or
2. In areas where the ultimate design wind speed,  $V_{ult}$ , is 140 mph (63.6 m/s) (~~53 m/s~~) or greater.

## **Chapter 3, Use and Occupancy Classification: *Significant Changes***

### **303.1 ASSEMBLY GROUP A**

The exception for Group E has been relocated to a stand-alone Section 303.1.3. It was revised to apply to assembly purposes “associated” with Group E in lieu of “accessory” to Group E.

Assembly Group A-2 has been relocated to a stand-alone Section 303.3, and now includes gaming areas. It was decided that the activities occurring in the gaming areas of casinos more closely resemble those of night clubs. There are distracting lights, sounds, decorations, and, in many cases, alcoholic beverages are being consumed. Due to the various distractions, it is possible that the occupants will become disoriented and confused in an emergency situation.

Commercial kitchens have historically been characterized as two different types, those that are **directly associated** with a restaurant or similar dining facility and those that are **independent** of any related dining area, such as a catering business. Associated commercial kitchens are now including in new Section 303.3. Commercial kitchens not associated with restaurants and cafeterias have been added to the F-1 list in Section 306.2.

### **From 2014 FBC Building:**

**303.1.3 Associated with Group E occupancies.** A room or space used for assembly purposes that is associated with a Group E occupancy is not considered a separate occupancy.

### **303.3 Assembly Group A-2**

Assembly uses intended for food and/or drink consumption including, but not limited to:

Banquet halls

Casinos (gaming areas)

Nightclubs

Restaurants, cafeterias and similar dining facilities (including associated commercial kitchens)

Taverns and bars

### **308 INSTITUTIONAL GROUP I**

Section 308 has been reworked. Group I-4, day care has been added as Group D has been deleted. Initial stage Alzheimer's facilities have been added to Group I-1. New section 308.3.1 contain text relocated from Section 308.3 and was revised to require such facilities to be sprinklered if designed in accordance with the Florida Building Code Residential. In section 308.4, Group I-2 occupancies include those medical care functions where the recipients receive care on a 24-hour basis, such as nursing homes and hospitals, where most of the care recipients are incapable of self-preservation and require the assistance of others under fire or other emergency conditions. New Section 308.6 provides classification criteria for Group I-4, day care facilities. New Group I-4 replaces Group D which has been deleted.

### **310 RESIDENTIAL GROUP R**

Sub-sections 310.3, 310.4, 310.5, and 310.6 have been added to Section 310. Congregate living facilities with more than 10 occupants have been added to the Group R-1 classification. Boarding houses classified as Group R-1 have been revised to apply to those with more than 10 occupants. Congregate living facilities with more than 16 occupants have been added to the Group R-2 classification. Boarding houses classified as Group R-2 have been revised to apply to those with more than 16 occupants. Boarding houses (nontransient) with 16 or fewer occupants and boarding houses (transient) with 10 or fewer occupants have been added to the Group R-3 classification. Applicability of congregate living facilities classified as Group R-3 has been clarified. Adult and child care facilities have been combined and revised to clarify that care facilities that can comply with the IRC are limited to 5 or fewer individuals receiving care. The listings of applicable uses of Group R- 4 have been revised to correlate the terminology and be more current with industry and licensing descriptions.

The direct relationship between Groups I-1 and R-4 is now more obvious because the types of uses is consistent between both occupancy groups. The only difference between the two classifications is the number of care recipients, as the expectation for both occupancy groups is that the individuals, although supervised, are individually capable of responding to an emergency without physical assistance from others.

## **Chapter 4, Special Detailed Requirements Based on Use and Occupancy: *Significant Changes***

### **402 OPEN MALL BUILDINGS**

The Entire section on malls has been reorganized and revised to include specific provisions for open mall buildings. Although the general provisions were intended to be applied equally to both open mall buildings and covered mall buildings, a number of the previous 2010 requirements did not fully address open mall conditions. The only new concept in the 2014 edition is the establishment of an "open mall building perimeter line" that is to be used to identify the boundary between what is considered to be part of the open mall building and what is outside of the building. This allows for the proper application of a variety of provisions, including those dealing with floor area and means

of egress. By definition, the perimeter line encircles all buildings which comprise the open mall building, including the open-air walkways and courtyards.

Open space requirements have been relocated to new Section 402.1.1. New language requires open malls to be surrounded on all sides by permanent open space not less than 60 feet. New section 402.1.2 specifies the determination of the open mall building perimeter line. The perimeter line is used for measuring the width of the required open space around an open mall building.

New section 402.4.3 requires a minimum of 20 feet of open space between floor and roof assemblies and mall of open mall buildings. New section 402.4.3.2 requires pedestrian walkways connecting balconies in an open mall building to be located not less than 20 feet from any other pedestrian walkway.

There are numerous other new and reworked sections in 402.

### **403.6.1 HIGH RISE BUILDINGS – FIRE SERVICE ACCESS ELEVATORS**

In buildings with an occupied floor more than 120 feet above the lowest level of fire department vehicle access, a minimum of two (or all elevators whichever is less) fire service access elevators are required. Each fire service elevator must have a minimum capacity of 3500 pounds. A minimum of two fire service elevators better ensures that there will be a fire service access elevator available for the firefighters' use in the performance of their duties.

#### **From 2014 FBC Building:**

**403.6.1 Fire service access elevator.** In buildings with an occupied floor more than 120 feet (36 576 mm) above the lowest level of fire department vehicle access, ~~a minimum of one fire service access elevator~~ no fewer than two fire service access elevators, or all elevators, whichever is less, shall be provided in accordance with Section 3007. Each fire service access elevator shall have a capacity of not less than 3500 pounds (1588 kg).

### **406.5.2.1 OPEN PARKING GARAGES – OPENINGS BELOW GRADE**

This new section requires that where openings below grade provide required natural ventilation, the outside horizontal clear space measure perpendicular to the opening shall be one and one-half times the depth of the opening. The width of the horizontal clear space shall be maintained from grade down to the bottom of the lowest required opening. As per 406.5.2, the aggregate length of the openings considered to be providing natural ventilation shall be not less than 40 percent of the perimeter of the tier. Interior walls shall be not less than 20 percent open with uniformly distributed openings.

**Exception:** Openings are not required to be distributed over 40 percent of the building perimeter where the required openings are uniformly distributed over two opposing sides of the building.



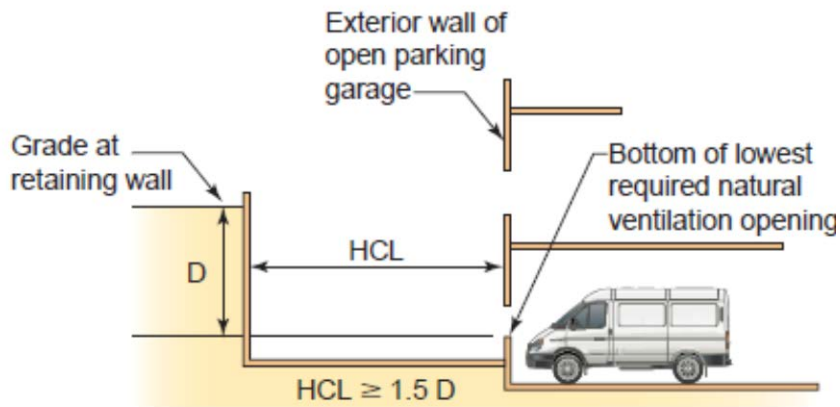

Parking garage openings below grade

**406.5.5 OPEN PARKING GARAGES—HEIGHT AND AREA INCREASES**

For determining area and height increases, the height of the “interior area of the side” is limited to 7 feet (2134 mm) for calculation purposes. In the determination of permitted area and height increases, the revised measurement method removes the unnecessary requirement for larger exterior openings based upon a tier height that exceeds the required minimum.

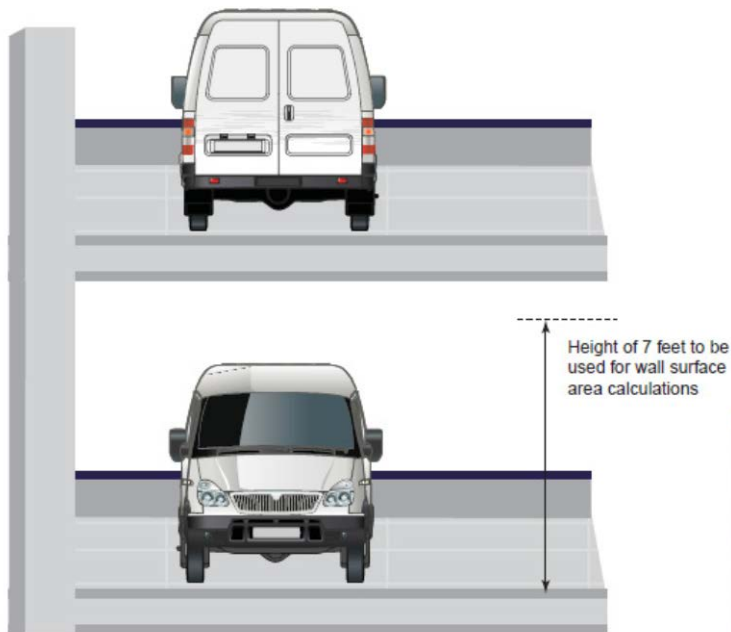

Surface area calculation for opening parking garage

**From 2014 FBC Building for heating equipment in repair garages:**

**406.8.5.1.1 Gas detection system components.** Gas detection system control units shall be listed and labeled in accordance with UL 864 or UL 2017. Gas detectors shall be listed and labeled in accordance with UL 2075 for use with the gases and vapors being detected.

**412.4.6.2 AIRCRAFT HANGAR FIRE AREAS**

This change allows the square footage of ancillary spaces not considered to be a direct part of the aircraft servicing area to not be included in the calculation of the fire area. It reduces the required minimum to a 1-hour fire barrier from a 2-hour fire barrier.

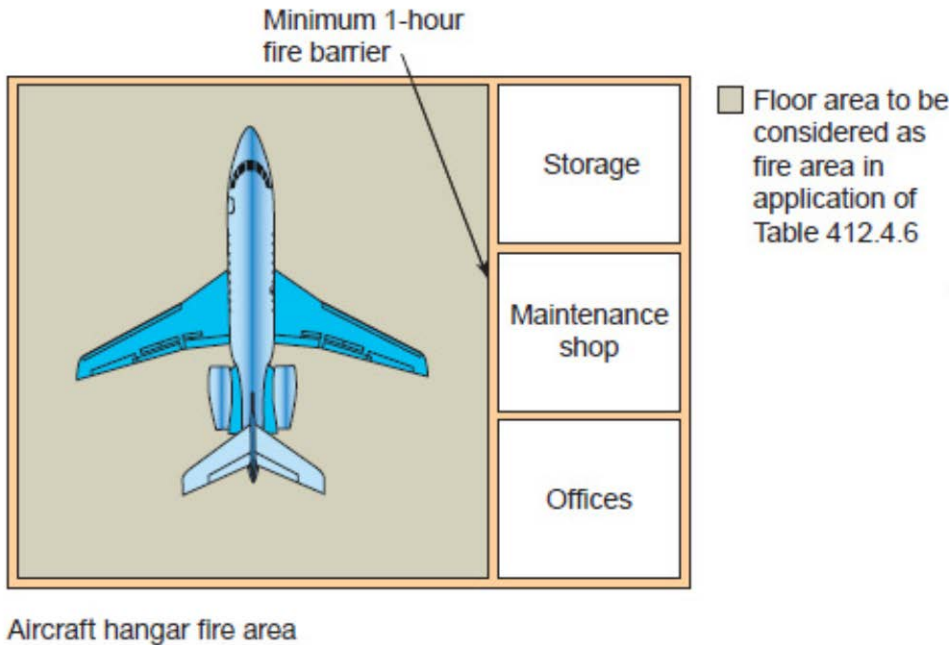

**422**

**AMBULATORY CARE FACILITIES**

In a multi-tenant or mixed-occupancy building where there are uses present other than an ambulatory care facility, a fire partition is now required between the care facility and those nonrelated spaces where the ambulatory care facility is intended to have at least four care recipients.

**SECTION 424 CHILDREN’S PLAY STRUCTURES**

This is a comprehensive new section with several sub-sections that is applicable to play structures inside all occupancies that exceed 10 feet in height and 150 square feet in area. Some of the provisions have been relocated from other parts of the code.

**Chapter 5, General Building Heights and Areas: *Significant Changes***

## 501.2

### ADDRESS IDENTIFICATION

A local fire code official can now require address numbers to be placed in additional locations to allow better response of emergency services.

#### From 2014 FBC Building:

**501.2 Address identification.** New and existing buildings shall be provided with *approved* address numbers or letters. Each character shall be ~~a minimum~~ not less than 4 inches (102 mm) in height and not less than 0.5 inch (12.7 mm) in width. They shall be installed on a contrasting background and be plainly visible from the street or road fronting the property. When required by the fire code official, address numbers shall be provided in additional *approved* locations to facilitate emergency response. Where access is by means of a private road and the building address cannot be viewed from the *public way*, a monument, pole or other *approved* sign or means shall be used to identify the structure. Address numbers shall be maintained.

## 505.2.2

### MEZZANINE MEANS OF EGRESS

The text of this section has been deleted and replaced with a general reference to Chapter 10. The means of egress requirements for a mezzanine are now consistent with those for other portions of the building for exit access. The consideration of an elevated floor level as a mezzanine no longer provides any special allowances for means of egress purposes.

## 506.2.1

### WIDTH LIMITS

The methodology for calculating the width “W” for calculating the appropriate allowable area increase for buildings fronting on public ways and/or open space has been clarified.

#### From 2014 FBC Building:

Weighted average:  $W = (L_1 \times w_1 + L_2 \times w_2 + L_3 \times w_3 \dots) / F$  (Equation 5-3)

Where:

$L_n$  = Length of a portion of the exterior perimeter wall.

$w_n$  = Width of open space associated with that portion of the exterior perimeter wall.

F = Building perimeter that fronts on a *public way* or open space having a width of 20 feet (6096 mm) or more.

Exception: Where ~~when~~ the building meets the requirements of Section 507, *as applicable*, except for compliance with the 60-foot (18 288 mm) *public way* or yard requirement, and the value of W is greater than 30 feet (9144 mm), the value of W divided by 30 shall be limited to a maximum of 2.

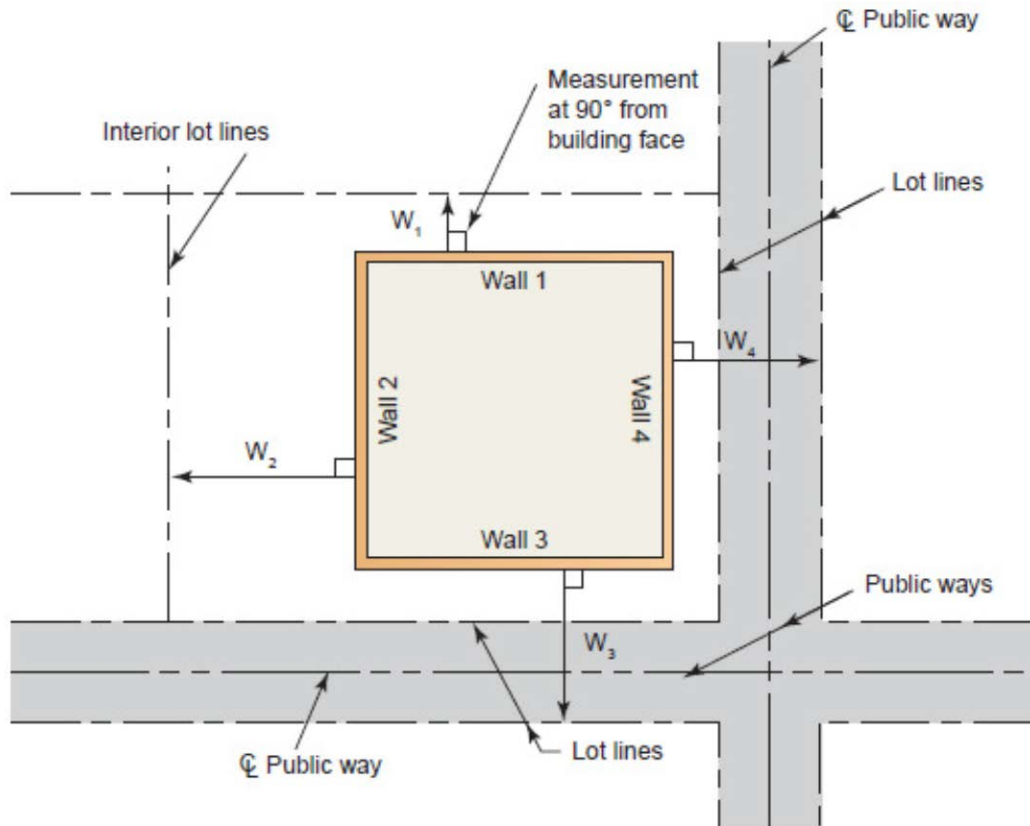

Allowable area frontage increase

**507.1  
UNLIMITED AREA BUILDINGS – GENERAL**

An exception was added to allow accessory occupancies in accordance with Section 508.2 to be located in unlimited area buildings. New language has been added to clarify the measurement of the width of yards and public ways for unlimited area buildings.

**From 2014 FBC Building:**

The area of buildings of the occupancies and configurations specified ~~herein~~ in Sections 507.1 through 507.12 shall not be limited.

**Exception:** Other occupancies shall be permitted in unlimited area buildings in accordance with the provisions of Section 508.2.

Where Sections 507.2 through 507.12 require buildings to be surrounded and adjoined by public ways and yards, those open spaces shall be determined as follows:

1. Yards shall be measured from the building perimeter in all directions to the closest interior lot lines or to the exterior face of an opposing building located on

the same lot, as applicable.

2 Where the building fronts on a public way, the entire width of the public way shall be used.

**509**

**SPECIAL PROVISIONS INCIDENTAL USES**

Provisions for incidental uses have been clarified by relocating the criteria from the mixed-occupancy provisions to this revised stand-alone section specific to incidental uses.

**TABLE 508.25 509**

This table was revised to require and only allow an automatic sprinkler system wherever an automatic fire extinguishing system had previously been required within the table for fire protection at incidental rooms and areas. There were also minor changes to some room or area descriptions as shown below. The list of incidental uses now includes waste and linen collection rooms in Group B ambulatory care facilities and such rooms must have a minimum 1-hour fire-resistance-rated separation.

<b>TABLE <del>508.25</del> 509</b>	
<b>Incidental Accessory Occupancies <u>Uses</u></b>	
ROOM OR AREA	SEPARATION AND/OR PROTECTON
Laboratories and vocational shops, not classified as Group H, located in a Group E or I-2 occupancy	1 hour or provide automatic <del>fire extinguishing</del> <u>sprinkler system</u>
Laundry rooms over 100 sq. ft.	1 hour or provide automatic <del>fire extinguishing</del> <u>sprinkler system</u>
Group I-3 cells equipped with padded surfaces	1 hour
Waste and linen collection rooms located in either Group I-2 occupancies or <u>ambulatory care facilities</u>	1 hour
<del>Group I-2</del> Waste and linen collection rooms over 100 sf	1 hour or provide automatic fire extinguishing <u>sprinkler system</u>
Stationary storage battery systems having a liquid electrolyte capacity of more than 50 gallons <u>for flooded lead-acid, nickel cadmium or VRLA, or more than 1,000 pounds for lithium-ion and lithium metal polymer</u> used for facility standby power, emergency power or <del>uninterrupted</del> <u>uninterruptable</u> power supplies	1 hour in Group B, F, M, S and U occupancies: 2 hour in Group A, E, I, and R occupancies

**510.4  
PARKING BENEATH R-4**

The number of stories to be used in determining the height in stories is now in accordance with Section 903.2.11.3 and shall include the parking garage as a story.

**From 2014 FBC Building:**

Where a maximum one-story above grade plane Group S-2 parking garage, enclosed or open, or combination thereof, of Type I construction or open of Type IV construction, with grade entrance, is provided under a building of Group R, the number of stories to be used in determining the minimum type of construction shall be measured from the floor above such a parking area. The number of stories to be used in determining the height in stories in accordance with Section 903.2.11.3 shall include the parking garage as a story. The floor assembly between the parking garage and the Group R above shall comply with the type of construction required for the parking garage and shall also provide a fire-resistance rating not less than the mixed occupancy separation required in Section 508.4.

**Chapter 6, Types of Construction: Significant Changes**

**TABLE 601  
FIRE RESISTANCE RATING REQUIREMENTS FOR BUILDING ELEMENTS**

The Florida-specific amendments to Table 601 have been deleted and the fire resistance rating requirements are now consistent with the base code.

**Table 602  
FIRE RESISTANCE RATING REQUIREMENTS FOR EXTERIOR WALLS**

The Florida-specific amendments to Table 602 have been deleted and the fire resistance rating requirements are now consistent with the base code. A new note (h) has been added permitting nonbearing exterior walls with unlimited area of unprotected openings per Table 705.8 to have a fire-resistance rating of 0 hrs.

**From 2014 FBC Building:**

<b>TABLE 602 FIRE-RESISTANCE RATING REQUIREMENTS FOR EXTERIOR WALLS BASED ON FIRE RESISTANCE SEPARATION DISTANCE <sup>a,e,h</sup></b>				
<b>FIRE SEPARATION DISTANCE = <math>x</math> (feet)</b>	<b>TYPE OF CONSTRUCTION</b>	<b>GROUP H</b>	<b>GROUP F-1, M, S-1</b>	<b>GROUP A, B, E, F-2, I, R, S-2, U</b>
<b><math>x = 5^c</math></b>	<b>All</b>	<b>3</b>	<b>3</b>	<b>3</b>
		<b>3</b>	<b>2</b>	<b>1</b>
<b><math>5 \leq x &lt; 10</math></b>	<b>1-A</b>	<b>3</b>	<b>2</b>	<b>2</b>
	<b>Others</b>	<b>2</b>	<b>1</b>	<b>1</b>
<b><math>10 \leq x &lt; 30</math></b>	<b>1-A, 1-B IIB, VB Others</b>	<b>2</b>	<b>2</b>	<b>2</b>
		<b>1</b>	<b>0</b>	<b>0</b>
		<b>1</b>	<b>1</b>	<b>1</b>

X > 30	All	0	0	0
--------	-----	---	---	---

h. Where Table 705.8 permits nonbearing exterior walls with unlimited area unprotected openings, the required fire-resistance for the exterior walls is 0 hours.

## **Chapter 7, Fire and Smoke Protection Features: *Significant Changes***

### **701.2**

#### **MULTIPLE-USE FIRE ASSEMBLIES**

NEW SECTION: This clarification states that when a single fire assembly serves multiple purposes, such as a wall being used as a fire barrier and partition, all requirements for both classifications must be met. For example, a door in a 2 hour fire barrier that is required to meet both the 1-1/2 hour fire-resistance rating and the smoke and draft criteria for a door in a corridor wall.

**From 2014 FBC Building:**

**701.2 Multiple use fire assemblies.** Fire assemblies that serve multiple purposes in a building shall comply with all of the requirements that are applicable for each of the individual fire assemblies.

### **703.4**

#### **AUTOMATIC SPRINKLERS**

NEW SECTION: This clarification states that automatic sprinklers and fire suppression systems are not permitted to be included as part of a tested building element, component, or assembly in order to establish the fire-resistance rating.

**From 2014 FBC Building:**

**703.4 Automatic Sprinklers.** Under the prescriptive fire-resistance requirements of the *Florida Building Code, Building*, the fire-resistance rating of a building element, component or assembly shall be established without the use of *automatic sprinklers* or any other fire suppression system being incorporated as part of the assembly tested in accordance with the fire exposure, procedures, and acceptance criteria specified in ASTM E 119 or UL 263. However, this section shall not prohibit or limit the duties and powers of the *building official* allowed by Section 104.11.

### **703.7**

#### **MARKING AND IDENTIFICATION**

Formerly section 703.6, this change revised the size and location of identifying markings required on vertical fire assemblies in accessible above-ceiling spaces to improve visibility. The exception has not changed.

**From 2014 FBC Building:**

**703.6-703.7 Marking and identification.** *Fire walls, fire barriers, fire partitions, smoke barriers* and smoke partitions or any other wall required to have protected openings or penetrations shall be effectively and permanently identified with signs or stenciling. Such identification shall:

1. Be located in accessible concealed floor, floor-ceiling or *attic* spaces;
2. Be ~~repeated~~ located within 15 feet (4572 mm ) of the end of each wall and at intervals not exceeding 30 feet (9144 mm) measured horizontally along the wall or partition; and
3. Include lettering not less than ~~0.5 inch (12.7 mm)~~ 3 inches (76 mm) in height with a minimum 3/8 inch (9.5 mm) stroke in a contrasting color incorporating the suggested wording. “FIRE AND/OR SMOKE BARRIER—PROTECT ALL OPENINGS” or other wording.

Exception: Walls in Group R-2 occupancies that do not have a removable decorative ceiling allowing access to the concealed space.

**704.11**

**BOTTOM FLANGE PROTECTION**

The permitted span of lintels, shelf angles, and plates not requiring fire protection at the bottom flanges has been revised from 6 feet 0 inches to 6 feet 4 inches. This provides a slight increase of 4 inches to better accommodate an opening containing a pair of 3-foot doors.

**705.2**

**EXTERIOR WALLS PROJECTIONS**

A new table was added which establishes a minimum clear distance that is required between the leading edge of the projection and the line used to establish the fire separation distance.

<b>Table 705.2 Minimum Distance of Projection</b>	
<u>Fire Separation Distance (FSD)</u>	<u>Minimum Distance from Line Used to Determine FSD</u>
<u>0 feet to less than 2 feet</u>	<u>Projections not permitted</u>
<u>2 feet to less than 5 feet</u>	<u>24 inches</u>
<u>5 feet or greater</u>	<u>40 inches</u>

**705.2.3**

**COMBUSTIBLE PROJECTIONS**

Combustible projection limitations have been revised to include projections with greater fire separation distances than previously regulated

**From 2014 FBC Building:**



**705.2.3 Combustible projections.** Combustible projections extending to within 5 feet (1524 mm) of the line used to determine the *fire separation distance*, or located where openings are not permitted, or where protection of some openings is required shall be of at least 1-hour fire-resistance-rated construction, Type IV construction, fire-retardant-treated wood or as required by Section 1406.3.

Exception: Type  $\nabla$  VB construction shall be allowed for combustible projections in Group R-3 and U occupancies with a fire separation distance greater than or equal to 5 feet (1524 mm).

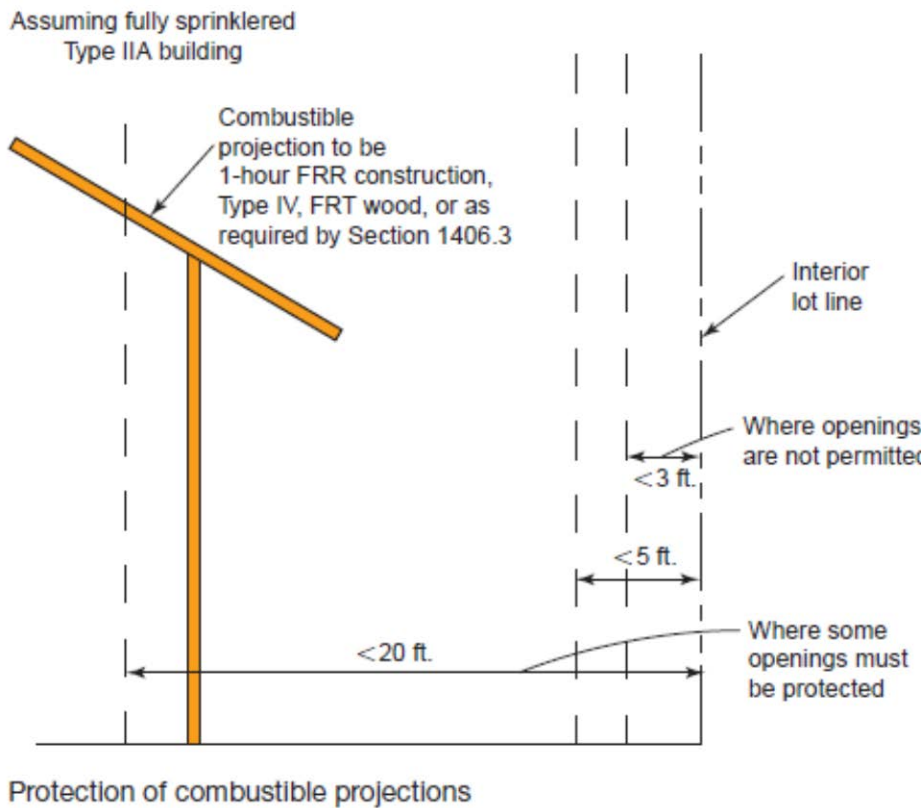

### 705.3 BUILDINGS ON THE SAME LOT

This was revised to require projections for buildings on the same lot to comply with the provisions of Section 705.2. In order to determine the required level of fire protection, if there are or will be multiple buildings on the same lot, the evaluations must now include the building projections.

### 706.2 DOUBLE FIRE WALLS

The use of a double wall in accordance with NFPA 221 is now permitted as an alternative to a single fire wall in order to satisfy the intended objective of structural stability.

## 706.4.1

### TOWNHOUSE FIRE SEPARATION

Similar to the 2010 Code, the 2014 code has had Florida specific fire separation language for townhouses inserted into the base code.

**From 2014 FBC Building:**

#### **706.4.1 Townhouse fire separation.**

706.4.1.1 Each townhouse shall be considered a separate building and shall be separated from adjoining townhouses by a party wall complying with Section 706.1.1 or by the use of separate exterior walls meeting the requirements of Tables 601 and 602 for zero clearance from property lines as required for the type of construction. Separate exterior walls shall include one of the following:

1. A parapet not less than 18 inches (457 mm) above the roof line.
2. Roof sheathing of noncombustible material or fire retardant treated wood, for not less than a 4 foot (1219 mm) width on each side of the exterior dividing wall.
3. One layer of 5/8 inch (15.9 mm) Type X gypsum board attached to the underside of roof decking, for not less than a 4 foot (1219 mm) width on each side of the exterior dividing wall.

706.4.1.2 When not more than three stories in height, townhouses may be separated by a single wall meeting the following requirements:

1. Such wall shall provide not less than a 2-hour fire-resistance rating. Plumbing, piping, ducts, electrical or other building services shall not be installed within or through the 2-hour wall, unless such materials and methods of penetration have been tested in accordance with Section 703.
2. Such wall shall be continuous from the foundation to the underside of no less than a 4-foot (1219 mm) width on each side of the wall shall be of noncombustible material, or fire-retardant-treated wood, or one layer of 5/8-inch (15.9 mm) Type X gypsum wallboard attached to the underside of the roof decking.
3. Each dwelling unit sharing such wall shall be designed and constructed to maintain its structural integrity independent of the unit on the opposite side of the wall.

Exception: Said wall may be penetrated by roof and floor structural members provided that the fire-resistance rating and the structural integrity of the wall is maintained.

## **706.6.2**

### **BUILDINGS WITH SLOPED ROOFS**

This new section addresses conditions where a sloped roof occurs on one or both sides of the fire wall parapet.

#### **From 2014 FBC Building:**

**706.6.2 Buildings with sloped roofs.** Where a *fire wall* serves as an interior wall for a building, and the roof on one side or both sides of the fire wall slopes toward the fire wall at a slope greater than two units vertical in 12 units horizontal (2:12), the *fire wall* shall extend to a height equal to the height of the roof located 4 feet (1219 mm) from the fire wall plus 30 inches (762 mm). In no case shall the extension of the fire wall be less than 30 inches (762mm).

## **707.8**

### **JOINTS**

This section was revised to clarify that compliance with Section 715 is required for joints of fire barriers with the underside of “a fire-resistance-rated” floor.

## **707.9**

### **VOIDS AT INTERSECTIONS**

This is a completely revised section requiring voids created at the intersection of a fire barrier and a non-fire-resistance-rate roof assembly to be filled with an approved material.

#### **From 2014 FBC Building:**

**707.9 Voids at intersections.** The voids created at the intersection of a fire barrier and a non-fire-resistance-rated roof assembly shall be filled. An approved material or system shall be used to fill the void, shall be securely installed in or on the intersection for its entire length so as not to dislodge, loosen or otherwise impair its ability to accommodate expected building movements and to retard the passage of fire and hot gases.

## **708.1**

### **GENERAL (FIRE PARTITIONS)**

Section 708 has been changed from “SHAFT ENCLOSURES” TO “FIRE PARTITIONS”. The requirement that walls separating individual tenant spaces be separated by a fire partition has been deleted. Associated exceptions have also been deleted.

## **709.4**

### **CONTINUITY OF SMOKE BARRIERS**

Smoke barrier walls used for elevator lobbies and areas of refuge are no longer required to extend from outside wall to outside wall.

## 712

### VERTICAL OPENINGS

This was a re-working of SECTION 712, which was formerly “HORIZONTAL ASSEMBLIES”. It now contains requirements previously applicable to shaft enclosures which are now covered in Section 713. Provisions for shaft enclosures have been reorganized for clarity and to remove conflicts resulting in inconsistent interpretations. Previous exceptions to shaft enclosures have been rewritten to become available options for dealing with various vertical openings encountered within a building.

### 713.13.4

#### TERMINATION ROOM

The level of fire protection required for a refuse or laundry chute termination room has been modified to provide consistency with those requirements mandated for the shaft that encloses the chutes.

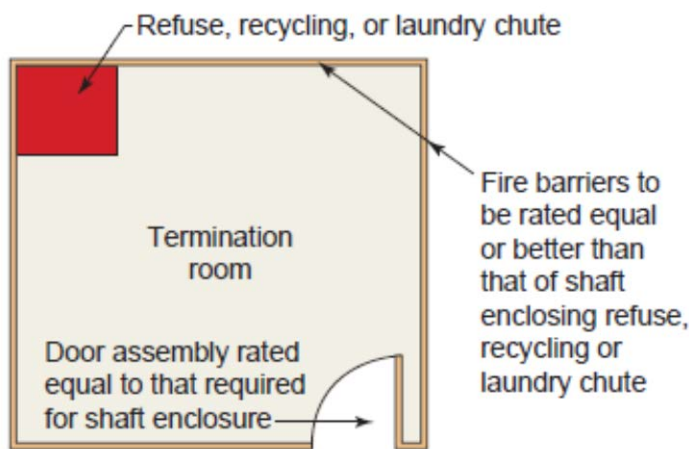

Refuse chute termination room

### 714.4.1.1.2

#### THROUGH-PENETRATION FIRESTOP SYSTEM

An approved through penetration firestop system used to protect floor penetrations of horizontal assemblies due to the presence of floor, tub, and shower drains is no longer required to have a T rating.

### 714.4.1.2

#### MEMBRANE PENETRATIONS

A new exception was added which exempts membrane penetrations by noncombustible items in concrete floors. An additional new exception was added that allows the ceiling membrane of a 1- or 2-hour fire rated floor/ceiling or roof/ceiling assembly to be interrupted by a double wood top plate of a fire rated wall.

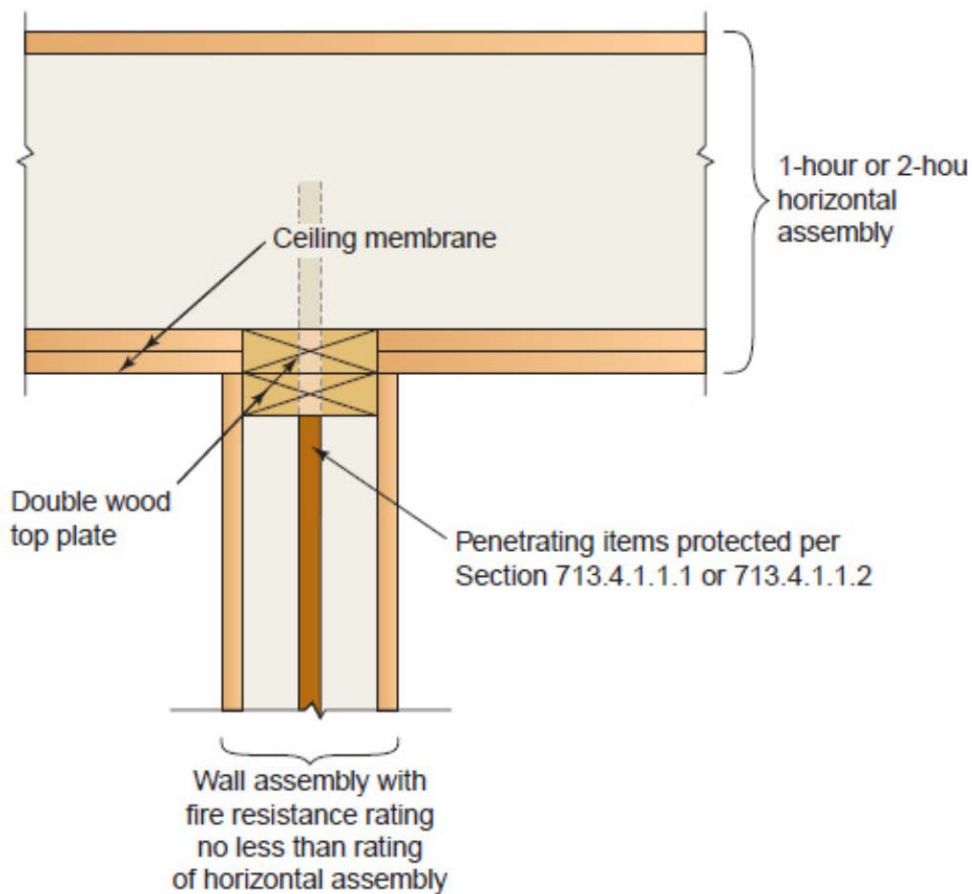

Horizontal assembly continuity at fire-rated wall

#### **714.5 PENETRATIONS IN SMOKE BARRIERS**

Formerly section 713.5, a newly defined “L” rating identifying the air leakage rate is now mandated for through-penetration fire stop systems that are utilized in smoke barrier construction.

#### **715.4 EXTERIOR CURTAIN WALL/FLOOR INTERSECTION**

A new exception added recognizing the use of ASTM E 119 as an acceptable evaluation method for addressing voids at the intersection of fire-resistance-rate floor assemblies and exterior curtain wall assemblies where the vision glass extends down to the finished floor level.

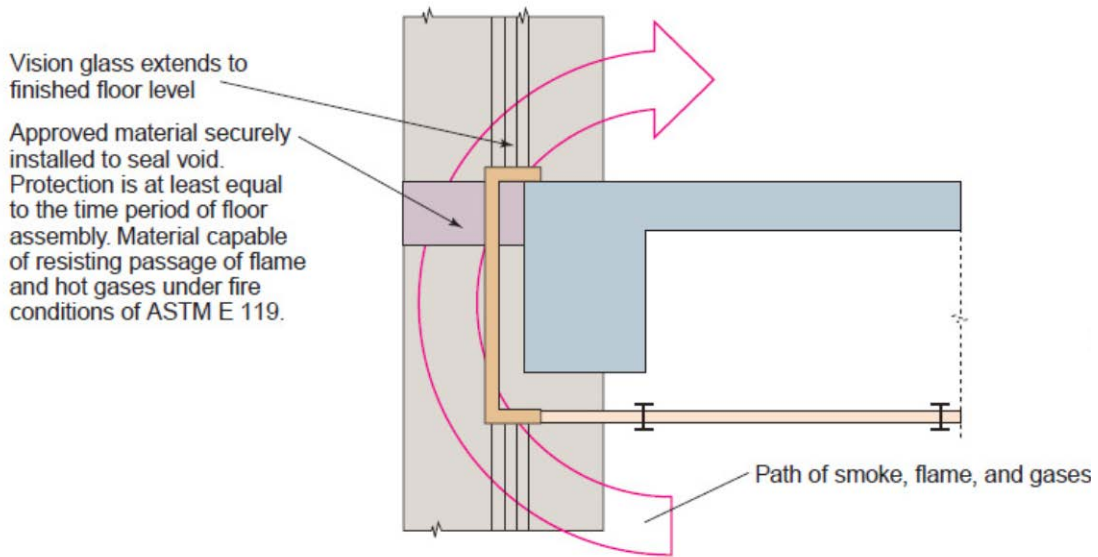

Joint protection at exterior curtain wall/floor intersection

**715.5.4  
WIRED GLASS**

Provisions for using wired glass without compliance with the applicable test standards have been deleted, along with Table 715.5.4.

**716.3  
MARKING FIRE-RATED GLAZING ASSEMBLIES**

A new Table 716.3 was added to define and relate the various test standards for fire-rated glazing to the designations used to mark such glazing

**TABLE 716.3 Marking Fire-Rated Glazing Assemblies**

<u>Fire Test Standard</u>	<u>Marking</u>	<u>Definition Of Marking</u>
<u>ASTM E 119 or UL 263</u>	<u>W</u>	<u>Meets wall assembly criteria.</u>
<u>NFPA 257 or UL 9</u>	<u>OH</u>	<u>Meets fire window assembly criteria including the hose stream test.</u>
<u>NFPA 252 or UL 10B or UL 10C</u>	<u>D</u>	<u>Meets fire door assembly criteria.</u>
	<u>H</u>	<u>Meets fire door assembly "Hose Stream" test.</u>
	<u>T</u>	<u>Meets 450° F temperature rise criteria for 30 minutes</u>
	<u>XXX</u>	<u>The time in minutes of the fire resistance or fire protection rating of the glazing assembly</u>

FOR SI: °C = [(°F) - 32]/1.8.

**Table 716.5**

**OPENING FIRE PROTECTION ASSEMBLIES, RATINGS AND MARKINGS**

This table has been revised and expanded to include the maximum size and marking requirements for door vision panels and the minimum assembly rating, including glazing marking requirements for sidelights and transoms.

**716.5.5.1**

**GLAZING IN DOORS**

This section was renumbered and revised to make the size limits for fire protection glazing in 60- and 90-minute doors in interior exit stairways and ramps and passageways consistent with the size limits in 60- and 90-minute doors elsewhere in the code.

**716.6**

**OPENING PROTECTIVES**

Formerly Section 715, this entire section has been reorganized for clarity and ease of use. Table 716.6, formerly Table 715.5, was revised to identify the markings required on fire-rated glazing.

Table 716.6 Fire Window Assembly Fire-Protection Ratings			
Type of <u>Wall Assembly</u>	Required <u>Wall Assembly Rating (Hours)</u>	Minimum Fire Window Assembly Rating (Hours)	<u>Fire Rated Glazing Marking</u>
Interior Walls			
Fire Walls	All	NP <sup>a</sup>	<u>W-xxx<sup>b</sup></u>
Fire Barriers	>1 1	NP <sup>a</sup> Np <sup>a</sup>	<u>W-xxx<sup>b</sup></u> <u>W-xxx<sup>b</sup></u>
<u>Incidental use areas (707.3.7)</u> <u>Mixed-occupancy separations (707.3.9)</u>	1	$\frac{3}{4}$	<u>OH-45 or W-60</u>
Fire Partitions	1 0.5	$\frac{3}{4}$ $\frac{1}{3}$	<u>OH-45 or W-60</u> <u>OH-20 or W-30</u>
Smoke Barriers	1	$\frac{3}{4}$	<u>OH-45 or W-60</u>
Exterior Walls	>1 1 <u>0.5</u>	1 $\frac{1}{2}$ $\frac{3}{4}$ $\frac{1}{2}$	<u>OH-90 or WXXX<sup>b</sup></u> <u>OH-45 or W-60</u> <u>OH-20 or W-30</u>
Party Wall	ALL	NP	<u>Not Applicable</u>
NP = Not Permitted			
a. Not permitted except <u>fire-resistance rated glazing assemblies tested to ASTM E 119 or UL 263 as specified in Section 716.2.</u>			
b. <u>XXX = the fire rating duration period in minutes which shall be equal to the fire resistance rating required for the wall assembly.</u>			

#### 717.5.4

#### FIRE PARTITIONS

Fire dampers are no longer required in duct and air transfer openings that penetrate fire partitions provided:

- it is a ducted HVAC system.
- the fire-resistance rating of the fire partition is 1 hour or less.
- it is not a Group H occupancy.
- the building is equipped with an automatic sprinkler system.

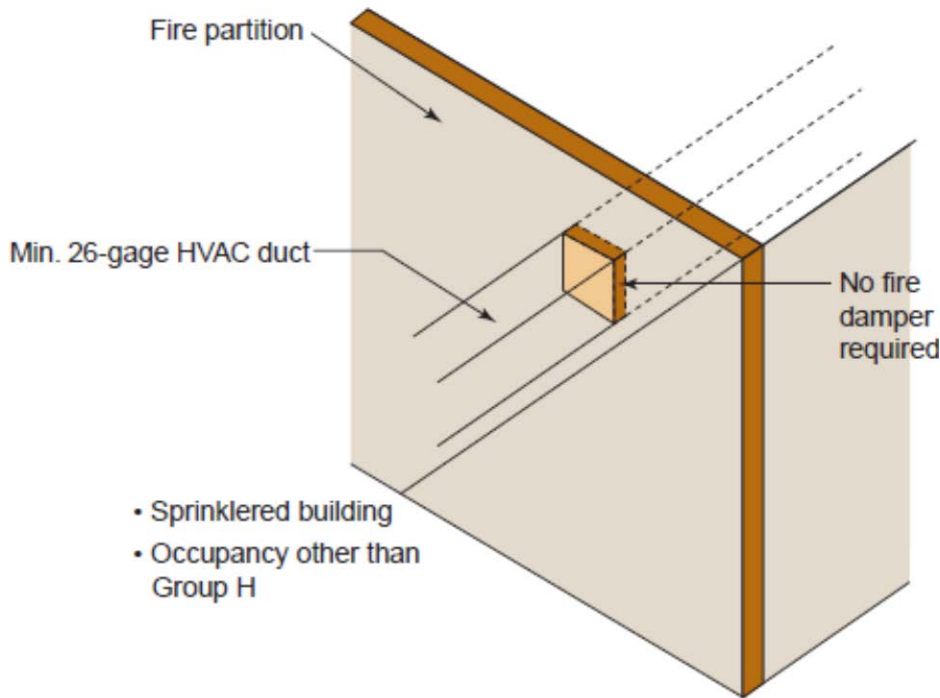

Fire damper omission in fire partition

### Chapter 8, Interior Finishes: *Significant Changes*

#### 803.12

#### HIGH-DENSITY POLYETHYLENE (HDPE) AND POLYPROPYLENE (PP)

Revised to add polypropylene as an interior finish (mainly in restroom partitions) that must to comply with the room corner test for interior wall or ceiling finish materials in accordance with NFPA 286

**From 2014 FBC Building:**

**803.12 High-density Polyethylene (HDPE) and Polypropylene (PP).** Where high-density polyethylene or polypropylene is used as an interior finish it shall comply with Section 803.1.2.



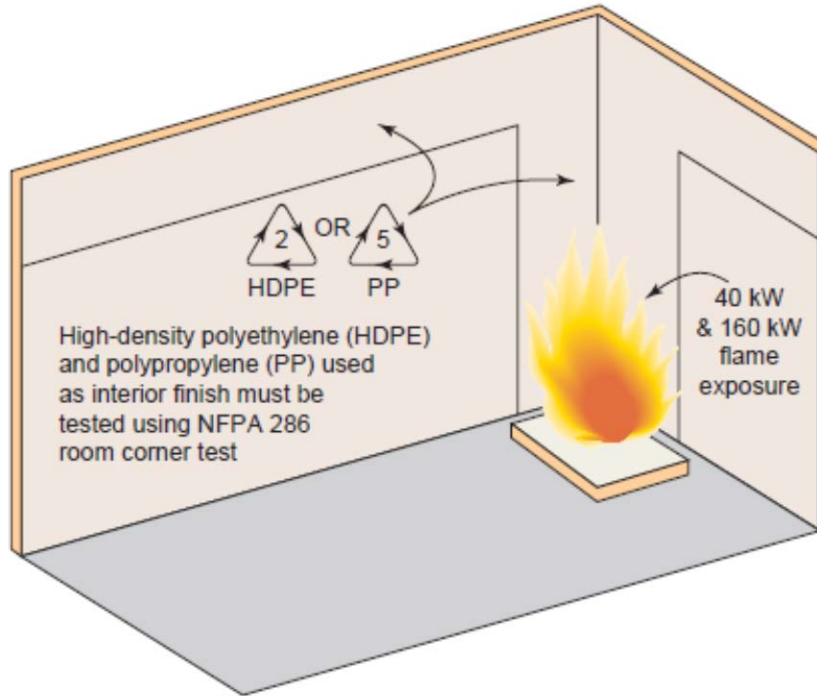

Room corner test

#### **804.4/804.4.1/804.4.2**

#### **INTERIOR FLOOR FINISH**

#### **REQUIREMENTS/TEST/REQUIREMENT/MINIMUM CRITICAL RADIANT FLUX**

These sections were revised to clarify that the floor finish in rooms or spaces that are not separated from the corridor by full-height walls must meet the same requirements as the corridor. These revisions will clarify how the “critical radiant flux” requirements are to be applied to fibrous floor finishes in rooms or spaces that are not separated from corridors by full-height partitions.

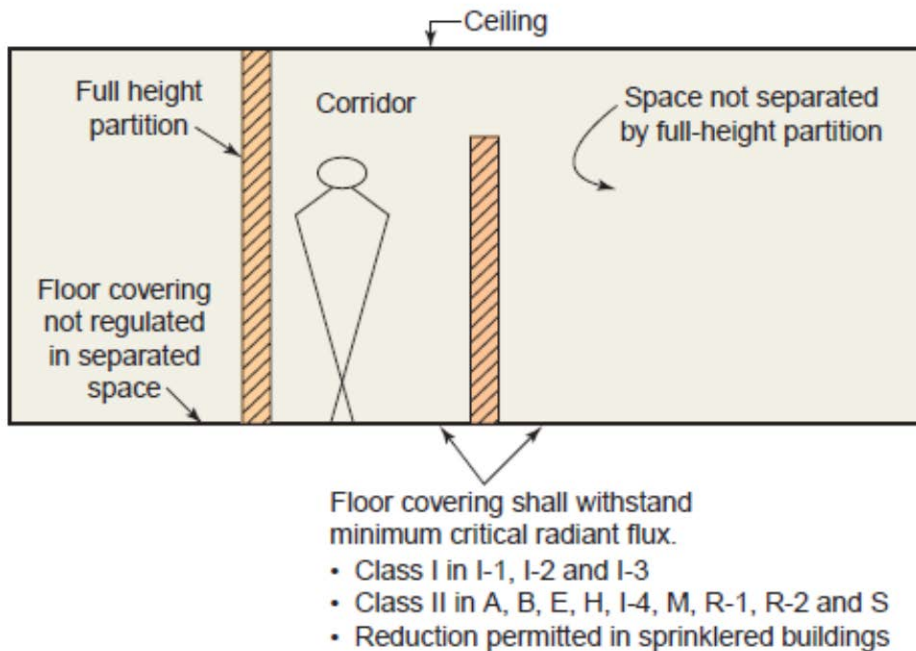

Interior floor finish requirements

## Chapter 9, Fire Protection Systems: *Significant Changes*

### 901.8

#### PUMP AND RISER ROOM SIZE

This is a new section which gives direction as to the design, sizes, and layout of pump and riser rooms so that adequate working clearances are provided for routine maintenance, repairs, and replacing equipment.

#### From 2014 FBC Building:

**901.8 Pump and riser room size.** Fire pump and automatic sprinkler system riser rooms shall be designed with adequate space for all equipment necessary for the installation, as defined by the manufacturer, with sufficient working room around the stationary equipment. Clearances around equipment to elements of permanent construction, including other installed equipment and appliances, shall be sufficient to allow inspection, service, repair or replacement without removing such elements of permanent construction or disabling the function of a required fire-resistance-rated assembly. Fire pump and automatic sprinkler system riser rooms shall be provided with a door(s) and unobstructed passageway large enough to allow removal of the largest piece of equipment.

### 903.2.2

#### AMBULATORY CARE FACILITIES

This section was revised to require all floors between the ambulatory health care facility

and the level of exit discharge serving it, including the level of exit discharge, to be sprinklered. A floor by floor basis will now be used to regulate automatic sprinkler systems for Group B ambulatory care facilities.

#### **903.2.4, 903.2.7, 903.2.9**

#### **GROUP F-1, GROUP M, AND GROUP S-1**

Occupancies that store, display, or manufacture upholstered furniture or mattresses now require automatic sprinkler systems. Such requirements are based on the area of the occupancy.

#### **903.2.11.3**

#### **BUILDINGS THREE STORIES OR MORE IN HEIGHT**

This section is a Florida specific supplement to the base code. Any building 3 stories or taller, shall be equipped with an automatic sprinkler system in accordance with 903.1.

#### **Exceptions:**

1. Single and two-family dwellings
2. Stand-alone parking garage separated from other structures by 20 feet
3. Telecommunications spaces in telecom buildings meeting FBC and State Fire Marshall standards
4. Telecommunication spaces if equipped with:
  - Air sampling smoke detection
  - Remote, proprietary, or central fire alarm monitoring
  - Automatic smoke exhaust system
  - 1 hr. fire-resistance separation wall from adjacent area
  - 2 hr. floor/ceiling assembly separating space from adjacent floors
  - All other areas have sprinkler systems
5. Sprinkler systems installed per standards (NFPA / FBC)

#### **904.3.2**

#### **ACTUATION**

Where multiple hazards could be involved in a fire, new language requires all hazards to be protected by a single system designed to protect all hazards that could become involved. As an alternative, multiple systems shall be permitted to be installed if they are designed to operate simultaneously.

#### **907.2.1**

#### **GROUP A**

Requirements for a fire alarm system in a building housing two or more Group A occupancies are now based on whether or not the occupancies are in separate fire areas.

#### **907.2.9.3**

#### **GROUP R-2 COLLEGE AND UNIVERSITY BUILDINGS**

This a new section requiring a smoke detection system tied into the occupant notification system in the specified public and common spaces of R-2 college and university

buildings. The required smoke alarms within individual dwelling and sleeping units are required to be interconnected with the building's fire alarm and detection system.

**From 2014 FBC Building:**

**907.2.9.3 Group R-2 college and university buildings.** An automatic smoke detection system that activates the occupant notification system in accordance with Section 907.5 shall be installed in Group R-2 college and university buildings in the following locations:

1. Common spaces outside of *dwelling units* and *sleeping units*.
2. Laundry rooms, mechanical equipment rooms, and storage rooms.
3. All interior corridors serving *sleeping units* or *dwelling units*.

Required smoke alarms in *dwelling units* and *sleeping units* in Group R-2 college and university buildings shall be interconnected with the fire alarm system in accordance with NFPA 72.

**Exception:** An automatic smoke detection system is not required in buildings that do not have interior *corridors* serving *sleeping units* or *dwelling units* and where each *sleeping unit* or *dwelling unit* either has a means of egress door opening directly to an exterior *exit access* that leads directly to an *exit* or a *means of egress door* opening directly to an exit.

**907.2.11.3**

**INTERCONNECTION**

This section was revised to apply the smoke alarm interconnection requirements to Group I-1. The revision allows physical interconnection to be omitted where wireless alarms are installed and all alarms sound simultaneously upon activation of one alarm.

**907.5.2.2.4**

**EMERGENCY VOICE/ALARM COMMUNICATION CAPTIONS**

This new Florida specific section (which replaces the old Emergency power section of the same number) requires mass notification fire alarm signals in large stadiums, arenas, and grandstands to have captioned messages.

**From 2014 FBC Building:**

**907.5.2.2.4 Emergency voice/alarm communication captions.** Where stadiums, arenas and grandstands are required to caption audible public announcements in accordance with the Florida Building Code, Accessibility, the emergency/voice alarm communication system shall also be captioned. Prerecorded or live emergency captions shall be from an approved location constantly attended by personnel trained to respond to an emergency.

## **908.7**

### **CARBON MONOXIDE PROTECTION**

This new Florida specific section requires carbon monoxide (CO) alarms in new and existing buildings in Group R and I Occupancies with attached garages or fuel burning appliances *Relocated from FBC-B 2010, Section 916.*

## **Chapter 10, Means of Egress: *Significant Changes***

### **1005.1 through 1005.6**

#### **MEANS OF EGRESS SIZING**

Provisions for means of egress width have been substantially reorganized for clarity. A new exception was added for stairways for all groups other than Group H and I-2. These revisions now allow the use of a stairway means of egress factor of 0.2 in buildings with a sprinkler system in accordance with Section 903.3.1.1 or 903.3.1.2 and an emergency voice/alarm communication system in accordance with Section 907.5.2.2.

### **1008.1.1**

#### **SIZE OF DOORS**

A Florida specific addition: any building that is less than 400 square feet and that is intended for use in conjunction with a one or two family residence is NOT subject to door height and width requirements.

### **1008.1.4.5**

#### **PROTECTION DEVICES FOR EMERGENCY ESCAPE AND RESCUE OPENINGS**

This Florida specific addition allows for temporary hurricane protection devices to be placed on emergency escape openings in Group R occupancies, during the threat of a storm. The hurricane protection devices cannot be located within a garage without a door leading to the exterior, and must be on first floor.

## **1009**

### **STAIRWAYS**

Section 1009 has been extensively revised to coordinate and clarify the provisions for unenclosed interior stairways and ramps that can be used as a portion of the means of egress. The many revisions are primarily a clarification. The term exit enclosure has been deleted. The terms “interior exit ramp, interior exit stairway, exit access ramp, and exit access stairway” have been added to clarify the enclosure requirements. The changes are based on the following concepts:

- All stairs within a building are elements of the means of egress system and must comply with Chapter 10
- Unenclosed stairways are not exits
- All exit stairways must be enclosed with a fire-resistance-rated enclosure
- Exit access stairways may be open unless enclosure is required based on shaft provisions
- Exit access travel distance is measured to an entrance to an exit
- Exit access travel distance includes the travel distance on exit access stairways

- Entrances to exits on each story are not mandatory and access to exits on other stories is permissible within certain limitations

## 1011.2

### FLOOR-LEVEL EXIT SIGNS IN GROUP R-1

This new section requires low-level exit signs in compliance with Section 1011.5 in Group R-1 occupancies where exit signs are required by Section 1011. The bottom of the sign is required to be between 10 and 12 inches of the floor, and is required to be flush-mounted to the door or wall.

**From 2014 FBC Building:**

**1011.2 Floor-level exit signs in Group R-1.** Where exit signs are required in Group R-1 occupancies by Section 1011.1, additional low-level exit signs shall be provided in all areas serving guestrooms in Group R-1 occupancies and shall comply with Section 1011.5.

The bottom of the sign shall be not less than 10 inches (254 mm) nor more than 12 inches (305 mm) above the floor level. The sign shall be flush mounted to the door or wall. Where mounted on the wall, the edge of the sign shall be within 4 inches (102 mm) of the door frame on the latch side.

## 1021.2

### EXITS FROM STORIES

Exits are now permitted to be arranged where they serve a portion of a story instead of requiring that all of the required exits from the story be accessible to all of the occupants.

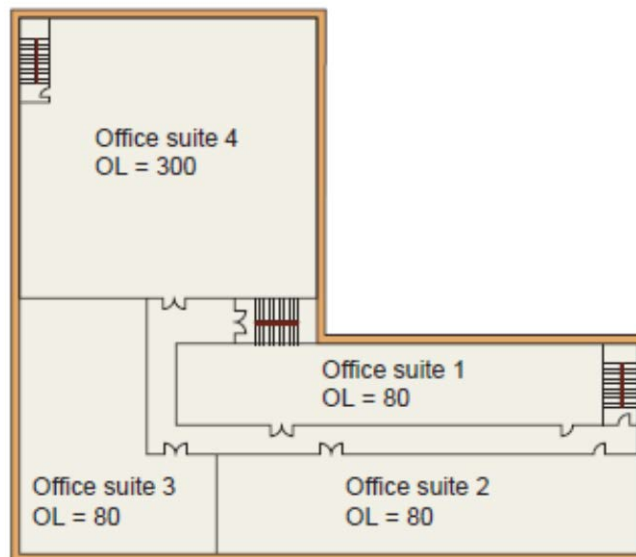

Exits serving specific spaces or areas

### 1021.2.3

#### SINGLE-STORY OR MULTI-STORY DWELLING UNITS

A new section clarifies when a single exit is permitted within or from an individual dwelling unit. Changes to Section 1021.2 and the tables will also provide a second option for compliance.

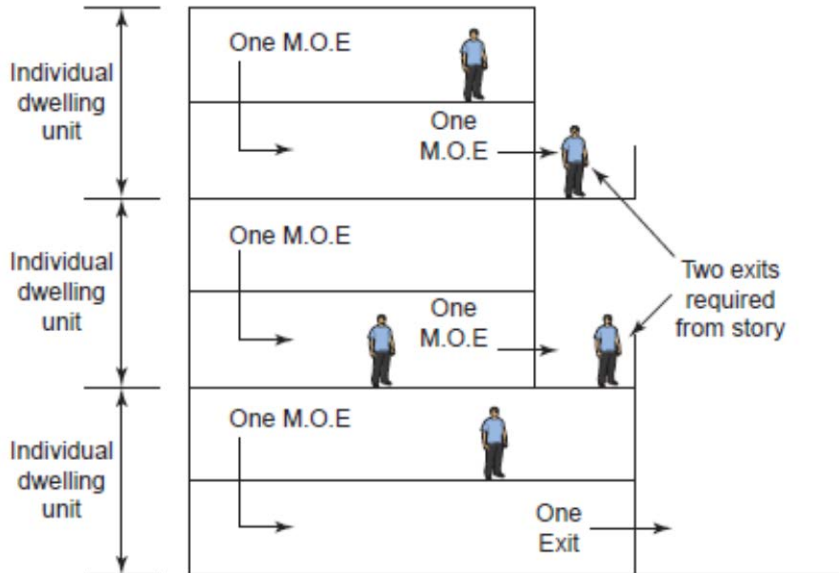

Single exit permitted within or from single-or multi-story dwelling unit if:

- Unit complies with 1015.1 as space with one means of egress, and
- Discharges directly to exterior at level of exit discharge, or
- Exit access outside unit provides access to not less than two exits

Egress from multistory dwelling units

### 1022.5

#### PENETRATIONS

A new exception permits membrane penetrations on the outside of interior exit stairways and ramps provided they are protected in accordance with Section 714.3.2.

## Chapter 12, Interior Environment: *Significant Changes*

### 1203.1

#### GENERAL (VENTILATION)

New language has been added describing a building as “too tight” where the air infiltration rate is less than 5 air changes per hour when tested at 0.3 inch water column. Language permitting compliance with ASHRAE 62.1 in lieu of Section 403.1 through 403.3 has been deleted. If a dwelling unit is tested with a blower door and it is determined that there is not an adequate number of air changes provided in the building, the option of natural ventilation rather than mechanical is now unavailable.

## 1203.2

### VENTILATION OF ATTIC SPACES

This section was revised to change the base requirement for net free ventilation area to 1/150th of the area of the space ventilated. Exception permitting unvented attics designed to eliminate the venting has been deleted.

#### New exceptions:

1. Net free cross-ventilation shall be permitted to be reduced to 1/300, where between 50% and 80% of the required ventilating area is provided by ventilators located in the upper portion of the ventilated space.
2. Net free cross-ventilation area shall be permitted to be reduced to 1/300, where a Class I or II vapor barrier is installed on the warm-in-winter side of the ceiling.
3. The building official can determine if attic ventilation is not necessary due to climate or atmospheric conditions.

## Chapter 14, Exterior Walls: *Significant Changes*

### 1403.5

#### VERTICAL AND LATERAL FLAME PROPAGATION

This new section requires testing and compliance with NFPA 285 where combustible water-resistive barriers are used on exterior walls of Types I, II, III, or IV construction that are higher than 40 feet.

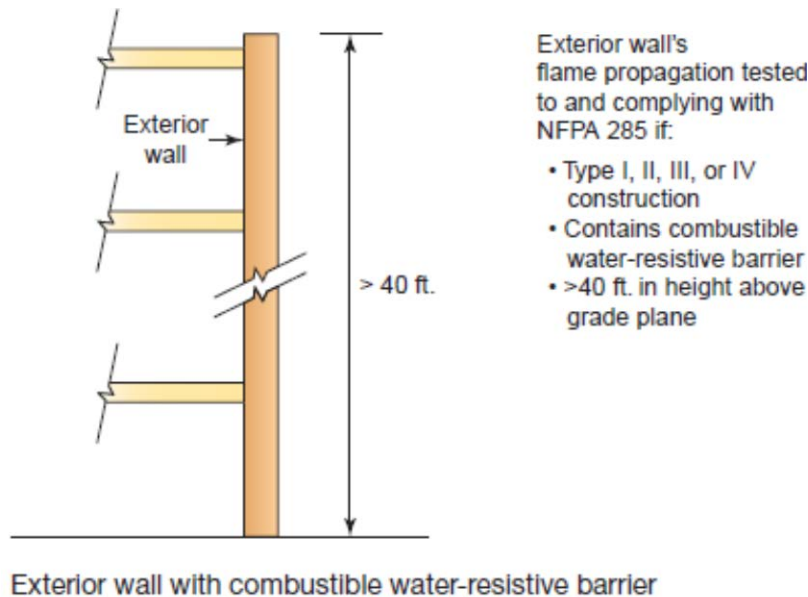



### **1403.8**

#### **TERMITE PROTECTION EXTERIOR WALLS**

A new Florida specific section (replacing the old 1403.8 drained wall...” section) which requires clearance of 6 inches to be maintained between the exterior wall covering and final earth grade in the exterior of the building, in order to provide for inspection of termite infestation.

#### **Exceptions:**

1. Paint or decorative cementitious finish < 5/8”
2. Access or vehicle ramps which rise to the interior finish floor elevation for the width of such ramps.
3. A 4-inch inspection space above patio, entry way, and garage slabs.
4. If the patio has been soli treated for termites, the finish elevation may match the building. (for masonry construction only).
5. Masonry veneers construction in accordance with Section 2114.2.

### **1404.5.1**

#### **ALUMINUM SIDING**

This extensive Florida specific change provides direction that the siding shall conform to the requirements of AAMA 1402 as modified by Florida Amendment TAS 202 and 203 in the HVHZ.

### **1404.12**

#### **POLYPROPYLENE SIDING**

Due to changes in building materials, polypropylene siding is now regulated for:

1. flame-spread
2. testing requirements,
3. fire-separation distance

### **1405.18**

#### **POLYPROPYLENE SIDING**

This new section limits the use of polypropylene siding to exterior walls of type VB construction in areas where wind speed does not exceed 100 mph, and building height is less than or equal to 40 feet in Exposure C. Where construction is located in areas where the basic wind speed exceeds 100 miles per hour (45 m/s), or building heights are in excess of 40 feet (12 192 mm), tests or calculations indicating compliance with Chapter 16 shall be submitted.

## **Chapter 15, Roof Assemblies and Rooftop Structures: *Significant Changes***

### **1503.6**

#### **CRICKETS AND SADDLES**

New exceptions permit unit skylights to be installed without a cricket or saddle when the skylights are installed in accordance with Section 2405.5 and flashed in accordance with the manufacturer’s instructions.

## 1507

### REQUIREMENTS FOR ROOF COVERINGS

Table 1507.2.7 was changed as follows:

TABLE 1507.2.7(1) Classification of Asphalt Roof Shingles per ASTM D 7158 <sup>a</sup>			
Max Basic Wind Speed From Fig. 1609A, B, C or ASCE 7	V <sub>asd</sub>	ASTM D 7158	ASTM D 3161
<b>110</b>	<b>85</b>	<b><u>D, G, OR H</u></b>	<b>A, <u>D or F</u></b>
<b>116</b>	<b>90</b>	<b><u>D, G, OR H</u></b>	<b>A, <u>D or F</u></b>
<b>129</b>	<b>100</b>	<b><u>G OR H</u></b>	<b>A, <u>D or F</u></b>
<b>142</b>	<b>110</b>	<b><u>G OR H</u></b>	<b>E</b>
<b>155</b>	<b>120</b>	<b><u>G OR H</u></b>	<b>E</b>
<b>168</b>	<b>130</b>	<b>H</b>	<b>E</b>
<b>181</b>	<b>140</b>	<b>H</b>	<b>E</b>
<b>194</b>	<b>150</b>	<b>H</b>	<b>E</b>

### 1507.2.8

#### UNDERLAYMENT APPLICATION

Underlayment requirements have been significantly revised. For roof slopes of 2:12 to less than 4:12, a two layer system is required. For roof slopes of 4:12 and greater, a single layer is permitted but underlayment is required to be ASTM D 226 Type II, ASTM D 4869 Type IV, or ASTM D 6757 (all are equivalent to a 30 lb. underlayment). Required fastening of underlayment to the sheathing has been significantly enhanced. Self-adhered underlayment complying with ASTM D 1970 is also permitted.

### 1507.17

#### PHOTOVOLTAIC MODULES/SHINGLES

This change requires all photovoltaic elements, including modules, shingles, or systems, to meet the general code requirements for roofing materials and rooftop structures.

## 1509

### ROOFTOP STRUCTURES

In addition to several technical changes and additions, the provisions addressing rooftop structures have been extensively reformatted to better organize and clarify the requirements.

## Chapter 16, Structural Design: *Significant Changes*

### Table 1604.3

#### DEFLECTION LIMITS

This change clarifies deflection limits for roof and wall members supporting plaster or stucco. Note J was added allowing screen surfaces to have a maximum 25% solid area to allow for kick plates.

TABLE 1604.3 Deflection Limits <sup>a,b,c,h,i</sup>			
Construction	L	S or W <sup>f</sup>	D + L <sup>d,g</sup>
Roof Members <sup>e</sup>			
Supporting plaster <u>or stucco</u> ceiling	l/360	l/360	l/240
Supporting non plaster ceiling	l/240	l/240	l/180
Not supported ceiling	l/180	l/180	l/120
Floor Members	l/360	----	l/240
Exterior Walls and Interior Finishes			
With <u>plaster or stucco finishes</u>	----	l/360	----
With <u>other brittle finishes</u>	----	l/240	----
With flexible finishes	----	l/240	----
Farm buildings	----	----	l/180
Greenhouses	----	----	l/120

Footnote F was also modified for the update to the new ultimate wind loads in the 2010 ASCE/SEI 7 (ASCE 7-10), *Minimum Design Loads for Buildings and Other Structures*.

**From 2014 FBC Building:**

f. The wind load is permitted to be taken as ~~0.7~~ 0.42 times the “component and cladding” loads for the purpose of determining deflection limits herein.

**1605.2**

**LOAD COMBINATIONS USING STRENGTH DESIGN LOAD AND RESISTANCE FACTOR DESIGN**

This change is a coordination of the Florida Building Code – Building with Section 2.3 of ASCE 7-10, and expanded to include loads due to fluids, F, and other lateral pressures, H, as well as ice loads. The self-restraining load, T, was deleted from the load combinations because it is indirectly accounted for under Section 1605.2.2 for other loads.

- $1.4(D + F)$  (Equation 16-1)
- $1.2(D + F + T) + 1.6(L + H) + 0.5(L_r \text{ or } S \text{ or } R)$  (Equation 16-2)
- $1.2(D + F) + 1.6(L_r \text{ or } S \text{ or } R) + 1.6H + (f_1L \text{ or } 0.5W)$  (Equation 16-3)
- $1.2(D + E) + 1.0W + f_1L + 1.6H + 0.5(L_r \text{ or } S \text{ or } R)$  (Equation 16-4)
- $1.2(D + E) + 1.0E + f_1L + 1.6H + f_2S$  (Equation 16-5)
- $0.9D + 1.0W + 1.6H$  (Equation 16-6)
- $0.9(D + E) + 1.0E + 1.6H$  (Equation 16-7)

where:

$f_1 = 1$  for floors in places of public assembly, for live loads in excess of 100 pounds per square foot (4.79kN/m<sup>2</sup>), and for parking garages, and 0.5 for other live loads.

$f_2 = 0.7$  for roof configurations (such as saw tooth) that do not shed snow off the structure, and = 0.2 for other roof configurations.

**Exceptions:**

1. Where other factored load combinations are specifically required by ~~the~~ other provisions of this code, such combinations shall take precedence.
2. Where the effect of  $H$  resists the primary variable load effect, a load factor of 0.9 shall be included with  $H$ , where  $H$  is permanent, and  $H$  shall be set to zero for all other conditions.

**1605.3**

**LOAD COMBINATIONS USING ALLOWABLE STRESS DESIGN**

This change is a coordination of the Florida Building Code – Building with Section 2.4 of ASCE 7-10, and expanded to include loads due to fluids,  $F$ , and other lateral pressures,  $H$ , as well as ice loads. The self-restraining load,  $T$ , was deleted from the load combinations because it is indirectly accounted for under Section 1605.3.2.1 for other loads.

$D + F$	<b>(Equation 16-8)</b>
$D + H + F + L + T$	<b>(Equation 16-9)</b>
$D + H + F + (L_r \text{ or } S \text{ or } R)$	<b>(Equation 16-10)</b>
$D + H + F + 0.75(L + T) + 0.75(L_r \text{ or } S \text{ or } R)$	<b>(Equation 16-11)</b>
$D + H + F + (0.6W \text{ or } 0.7E)$	<b>(Equation 16-12)</b>
$D + H + F + 0.45(0.75(0.6W) + 0.75L + 0.75(L_r \text{ or } S \text{ or } R))$	<b>(Equation 16-13)</b>
$D + H + F + 0.75(0.7E) + 0.75L + 0.75S$	<b>(Equation 16-14)</b>
$0.6D + 0.6W + H$	<b>(Equation 16-14 15)</b>
$0.6(D + F) + 0.7E + H$	<b>(Equation 16-16)</b>

**Exceptions:**

- 1-2. No changes
3. Where the effect of  $H$  resists the primary variable load effect, a load factor of 0.6 shall be included with  $H$ , where  $H$  is permanent, and  $H$  shall be set to zero for all other conditions.
4. In Equation 16-15, the wind load,  $W$ , is permitted to be reduced 10 percent for design of the foundation other than anchorage of the structure to the foundation in accordance with Exception 2 of Section 2.4.1 of ASCE 7.
5. In Equation 16-16,  $0.6D$  is permitted to be increased to  $0.9D$  for the design of special reinforced masonry shear walls complying with Chapter 21.

**Alternative Base Load Calculations**

$D + L + (L_r \text{ or } S \text{ or } R)$	<b>(Equation 16-17)</b>
$D + L + (0.6\omega W)$	<b>(Equation 16-18)</b>
$D + L + 0.6\omega W + S/2$	<b>(Equation 16-19)</b>
$D + L + S + 0.6\omega W/2$	<b>(Equation 16-20)</b>
$D + L + S + E/1.4$	<b>(Equation 16-21)</b>
$0.9D + E/1.4$	<b>(Equation 16-22)</b>

**No changes to exceptions.**

1609

**DETERMINATION OF WIND LOADS**

This change is an update and coordination with the latest wind load provisions in ASCE/SEI 7 (ASCE 7-10) and the wind load maps are based on  $V_{ult}$  which produces a strength level wind load similar to seismic load effects.

$$V_{asd} = V_{ult} \sqrt{0.6}$$

Equation 16-33, conversion of wind speed from  $V_{ult}$  to  $V_{asd}$

$V_{ult}$  = Ultimate design wind speeds.

$V_{ASD}$  = Nominal design wind speeds.

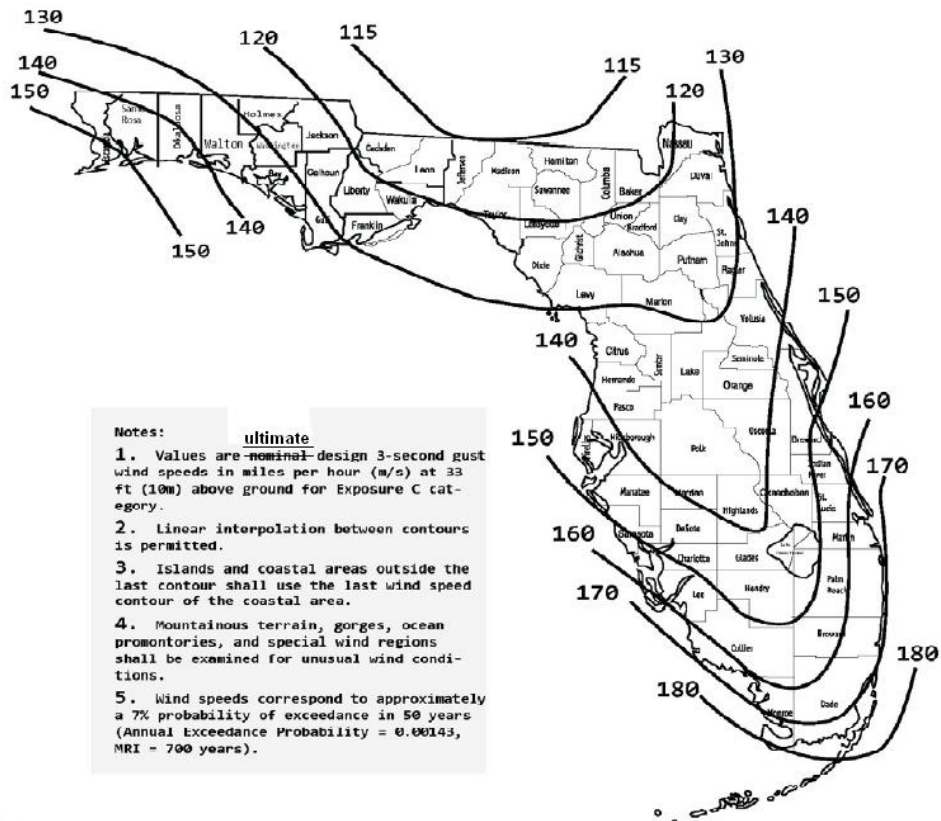

**Figure 1609A Ultimate Design Wind Speeds,  $V_{ult}$  For Risk Category II Buildings and Other Structures**

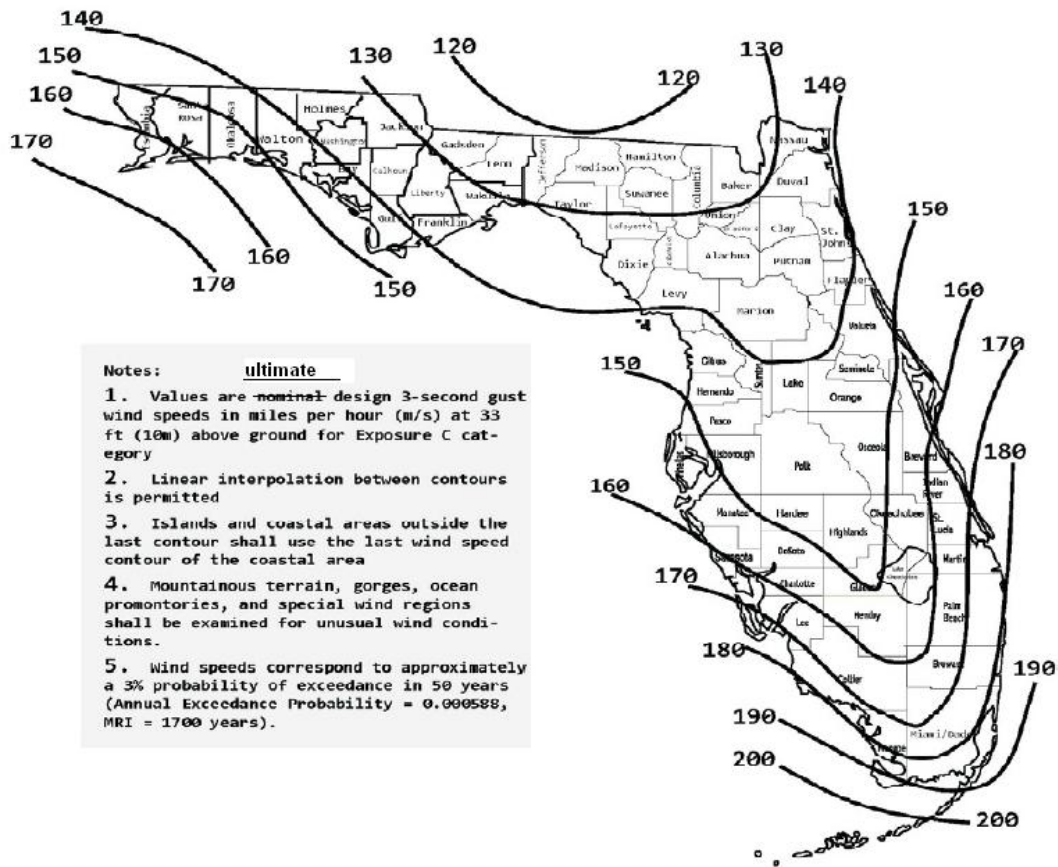

**Figure 1609B Ultimate Design Wind Speeds,  $V_{ult}$  For Risk Category III and IV Buildings and other Structures**

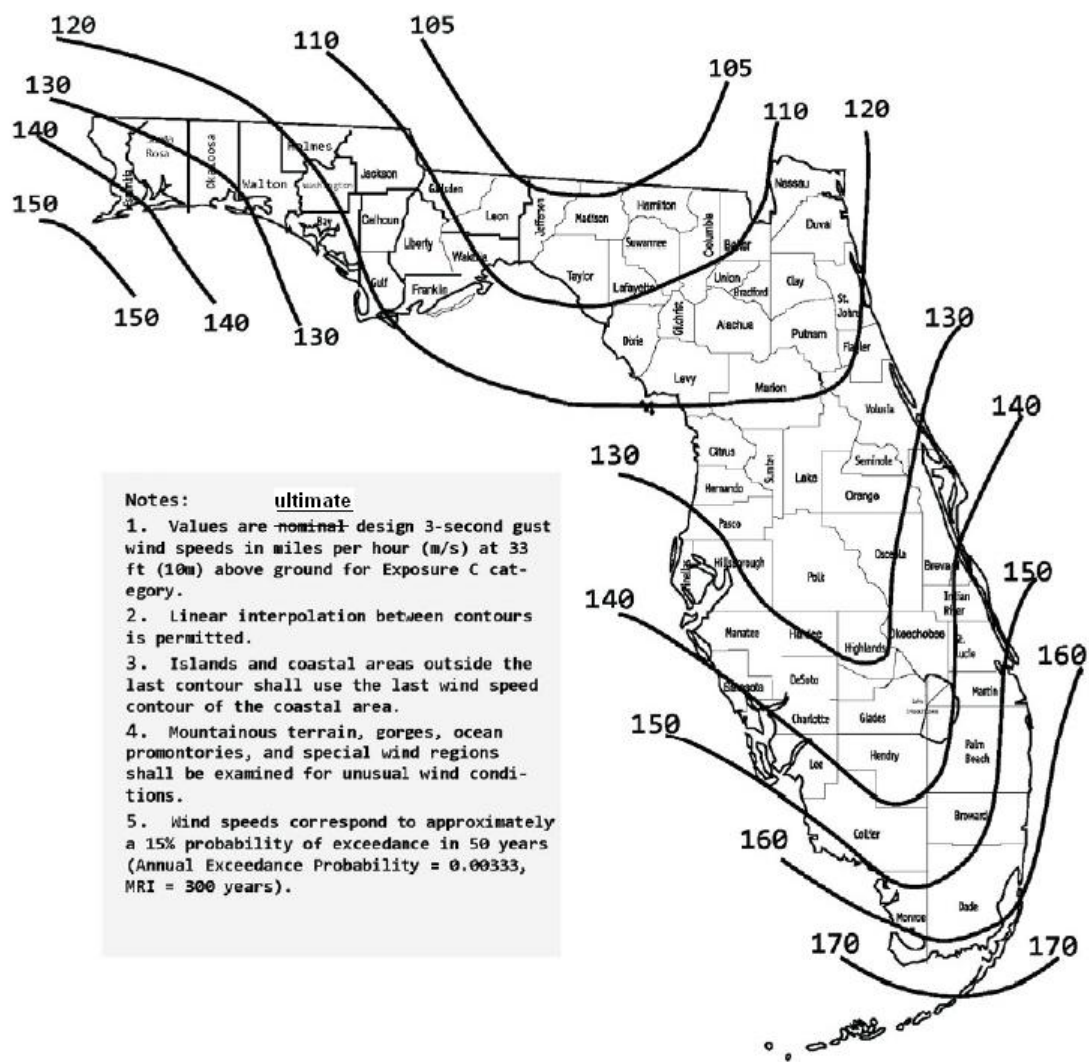

**Notes: ultimate**

1. Values are ~~nominal~~ design 3-second gust wind speeds in miles per hour (m/s) at 33 ft (10m) above ground for Exposure C category.
2. Linear interpolation between contours is permitted.
3. Islands and coastal areas outside the last contour shall use the last wind speed contour of the coastal area.
4. Mountainous terrain, gorges, ocean promontories, and special wind regions shall be examined for unusual wind conditions.
5. Wind speeds correspond to approximately a 15% probability of exceedance in 50 years (Annual Exceedance Probability = 0.00333, MRI = 300 years).

**Figure 1609C Ultimate Design Wind Speeds,  $V_{ult}$  For Risk Category I Buildings and other Structures**

<b>TABLE 1609.3.1 Wind Speed <u>Conversions</u> <sup>a,b,c</sup></b>											
$V_{ul}$	<u>100</u>	<u>110</u>	<u>120</u>	<u>130</u>	<u>140</u>	<u>150</u>	<u>160</u>	<u>170</u>	<u>180</u>	<u>190</u>	<u>200</u>
$V_{asd}$	<u>78</u>	<u>85</u>	<u>93</u>	<u>101</u>	<u>108</u>	<u>116</u>	<u>124</u>	<u>132</u>	<u>139</u>	<u>147</u>	<u>155</u>

a. Linear interpolation is permitted

b.  $V_{asd}$  = nominal design wind speed applicable to methods specified in Exceptions 1 through 5 of Section 1609.1.1

c.  $V_{ult}$  = ultimate design wind speeds determined from Figures 1609A, 1609B, or 1609C

### 1609.1.2

#### PROTECTION OF OPENINGS

Storage sheds that are less than 720 s.f. are not required to comply with the windborne debris standards of the code. Sunrooms, balconies or enclosed porches constructed under existing roofs or decks are not required to be protected provided the spaces are separated from the building interior by a wall and all openings are protected.

### 1609.4.2

#### SURFACE ROUGHNESS CATEGORIES

The language in the Surface Roughness C definition pertaining to short-term changes in the pre-existing terrain for the purposes of development has been deleted.

#### From 2014 FBC Building:

**Surface Roughness C.** Open terrain with scattered obstructions having heights generally less than 30 feet (9144 mm). This category includes flat open country, and grasslands. This surface roughness shall also apply to any building located within surface roughness B-type terrain where the building is within 100 feet horizontally in any direction of open areas of surface roughness C or D-type terrain that extends more than 600 feet (182.9 m) in the upwind direction and a width greater than 150 feet.

This course presents only a few of the many important changes from the 2010 Florida Building Code series and from the 2012 International Building Code (the new base code). While we have tried to include many of the significant changes, each building professional will have their own specialties and areas of expertise, making it incumbent on every Florida contractor to carefully study the code sections that most affect their professional practice.

Congratulations, you have completed this 2 CE hour Florida Advanced Building Code class.

### **Florida Building Code 2014: Highlights and Changes** **Questions for Advanced 2014 FBC Significant Code Changes** (answers in bold)

1. The 2014 Florida Building Code is based on
  - a. **2012 International Building Code**
  - b. 2010 International Building Code
  - c. 2009 NFPA Life Safety 101
  - d. None of the above
  
2. The 2014 Florida Building Code replaced the 2010 Code as of
  - a. January 1, 2014



- b. November 30, 2015
  - c. March 30, 2016
  - d. June 30, 2015**
3. For the purpose of inspection and record retention, site plans for a building may be maintained in the form of \_\_\_\_\_ copy at the worksite.
- a. a carbon
  - b. an electronic**
  - c. an approximate
  - d. none of the above
4. An AMBULATORY CARE FACILITY is defined as: Buildings or portions thereof used to provide \_\_\_\_\_, \_\_\_\_\_, \_\_\_\_\_, nursing or similar care on a less than 24-hour basis to persons who are rendered incapable *of self-preservation* by the services provided.
- a. medical
  - b. surgical
  - c. psychiatric
  - d. All of the above**
5. CONGREGATE LIVING FACILITIES are defined as a building or part thereof that contains sleeping units where residents share:
- a. kitchen facilities
  - b. bathroom facilities
  - c. bathroom and/or kitchen facilities**
  - d. recreation facilities
6. Initial stage Alzheimer's facilities have been added to Group:
- a. I-2
  - b. I-1**
  - c. R-3
  - d. R-4
7. New language requires open malls to be surrounded on all sides by permanent open space not less than:
- a. 300 feet
  - b. 15 feet
  - c. 60 feet**
  - d. 100 feet
8. In buildings with an occupied floor more than 120 feet above the lowest level of fire department vehicle access, each fire service elevator must have a minimum capacity of:
- a. 2000 pounds
  - b. 2500 pounds
  - c. 3500 pounds**
  - d. 5000 pounds

9. For Open Parking Garages, for determining area and height increases, the height of the “interior area of the side” is limited to \_\_\_\_\_ for calculation purposes.
- 9 feet
  - 5 feet
  - 7 feet**
  - 10 feet
10. A local fire code official can now require address numbers to be placed in \_\_\_\_\_ to allow better response of emergency services.
- patio areas
  - additional locations**
  - gardens
  - vehicles
11. Group I-3 cells equipped with padded surfaces require \_\_\_\_\_ separation and/or protection.
- 2 hour
  - 1 hour**
  - 3 hour
  - None of the above
12. Where Table 705.8 permits nonbearing exterior walls with unlimited area unprotected openings, the required fire-resistance for the exterior walls is \_\_\_\_\_ hours.
- 2
  - 1
  - 3
  - 0**
13. The permitted span of lintels, shelf angles, and plates not requiring fire protection at the bottom flanges has been revised from 6 feet 0 inches to:
- 5 feet
  - 6 feet 4 inches**
  - 7 feet
  - 6 feet 10 inches
14. The use of a double wall in accordance with NFPA 221 is now permitted as an alternative to a single fire wall in order to satisfy the intended objective of:
- sound proofing
  - eliminating the sprinkler system
  - smoke control
  - structural stability**
15. An approved through penetration firestop system used to protect floor penetrations of horizontal assemblies due to the presence of \_\_\_\_\_ is no longer required to have a T rating.
- laundry chutes

- b. **floor, tub, and shower drains**
  - c. electrical risers
  - d. ductwork
16. A newly defined \_\_\_\_\_ rating identifying the air leakage rate is now mandated for through-penetration fire stop systems that are utilized in smoke barrier construction.
- a. “AL”
  - b. “A”
  - c. “L”
  - d. “TP”
17. Provisions for using wired glass without compliance with the applicable test standards have been:
- a. **deleted**
  - b. revised
  - c. moved
  - d. clarified
18. Where high-density polyethylene or \_\_\_\_\_ is used as an interior finish it shall comply with Section 803.1.2.
- a. polycarbonate
  - b. polystyrene
  - c. **polypropylene**
  - d. None of the above
19. Occupancies that store, display, or manufacture upholstered furniture or mattresses now require:
- a. additional ventilation
  - b. wire glass
  - c. **automatic sprinkler systems**
  - d. all of the above
20. Any building that is less than \_\_\_\_\_ square feet and that is intended for use in conjunction with a one or two family residence is NOT subject to door height and width requirements.
- a. **400**
  - b. 250
  - c. 750
  - d. 625
21. A new exception permits \_\_\_\_\_ penetrations on the outside of interior exit stairways and ramps provided they are protected in accordance with Section 714.3.2.
- a. mechanical
  - b. horizontal
  - c. vertical
  - d. **membrane**
  - e.

22. Due to changes in building materials, polypropylene siding is now regulated for:
- flame-spread
  - testing requirements
  - fire separation distance
  - all of the above**
23. The use of polypropylene siding is limited to exterior walls of type VB construction in areas where wind speed does not exceed 100 mph, and building height is less than or equal to \_\_\_\_\_ feet in Exposure C.
- 40**
  - 50
  - 60
  - 30
24. Storage sheds that are less than \_\_\_\_\_ s.f. are not required to comply with the windborne debris standards of the code.
- 720**
  - 360
  - 900
  - 575
25. Surface Roughness C is open terrain with scattered obstructions having heights generally less than \_\_\_ feet.
- 40
  - 30**
  - 50
  - 25