



FM-300 Installation Instructions

Markar Architectural Products, Inc. a subsidiary of Adams Rite Manufacturing Co.
260 Santa Fe St, Pomona, CA 91767 909-623-2300 * 909-632-2370 fax www.markar.com

All holes in the door and frame must be drilled correctly and fasteners properly installed. Failure to use the fasteners supplied by Markar Architectural Products, Inc. will void the UL or WHI fire rated listing.

The Universal Screw Pack contains sheet metal, machine and self-drilling Tek screw. This allows three different installation options. If installing a wood or non-reinforced hollow metal door, follow option (A) in the instructions. Follow option (B) if the door is reinforced or at least 1/8" thick. If you use the self-drilling Tek screws (recommended for grouting frames), follow option (C). If the grout is hard, drilling a pilot hole can help.

- Perform each step of these instructions unless specifically labeled (A), (B), or (C).

- (1) Place hinge on frame as shown in Figure 1.
 - Allow 1/8" between top of hinge and underside of header
 - Allow 1/16" between stop and edge of hinge.
- (2) Mark all the hole locations on the door jamb with the hinge held firmly in place.
- (3) Center punch each hole. The use of the Markar MT-806 center punch can help center the hole so that the fasteners will enter straight. The taper on the tool sits in the countersunk hole on the hinge.
- (4) (A)&(B) Drill all the holes using a #25 bit.
- (5) (B) Tap the holes for a 10-24 thread.
- (6) Place the hinge on the edge of the door. Carefully line up the hinge with the top and back edges of the door.

(7) Mark all the hole locations on the door with the hinge held firmly in place.

(8) Center punch each hole.

(9) (A) & (B) Drill all the holes using a #25 bit.

(10) (A) Attach the hinge to the door with #10x1 1/4" flat head undercut sheet metal screws. OR

(10) (B) Tap the holes for a 10-24 thread. Attach the hinge to the door with 10-24 flat head undercut machine screws. OR

(10) (C) Attach the hinge to the door with #10x 1/2" flat head undercut self-drilling Tek screws.

- (11) Attach the hinge to the frame
 - (A) using #10x1 1/4" flat head undercut sheet metal screws. OR
 - (B) using 10-24 flat head undercut machine screws. OR
 - (C) using self-drilling Tek screws.

- (12) Close the door and check for proper alignment.
 - If the door requires adjustment for proper fit, make this adjustment by loosening screws on the frame leaf and shimming where needed using CHS-1 and CHS-2 shims.
 - Follow instructions on the box for field cut-down.
 - Hospital tips on hinges should be placed on the top of the door.

**PRODUCT MUST BE INSTALLED
ACCORDING TO ALL APPLICABLE
BUILDING AND LIFE SAFETY CODES**

FIGURE 1: HINGE PLACEMENT & CLEARANCE TEMPLATE

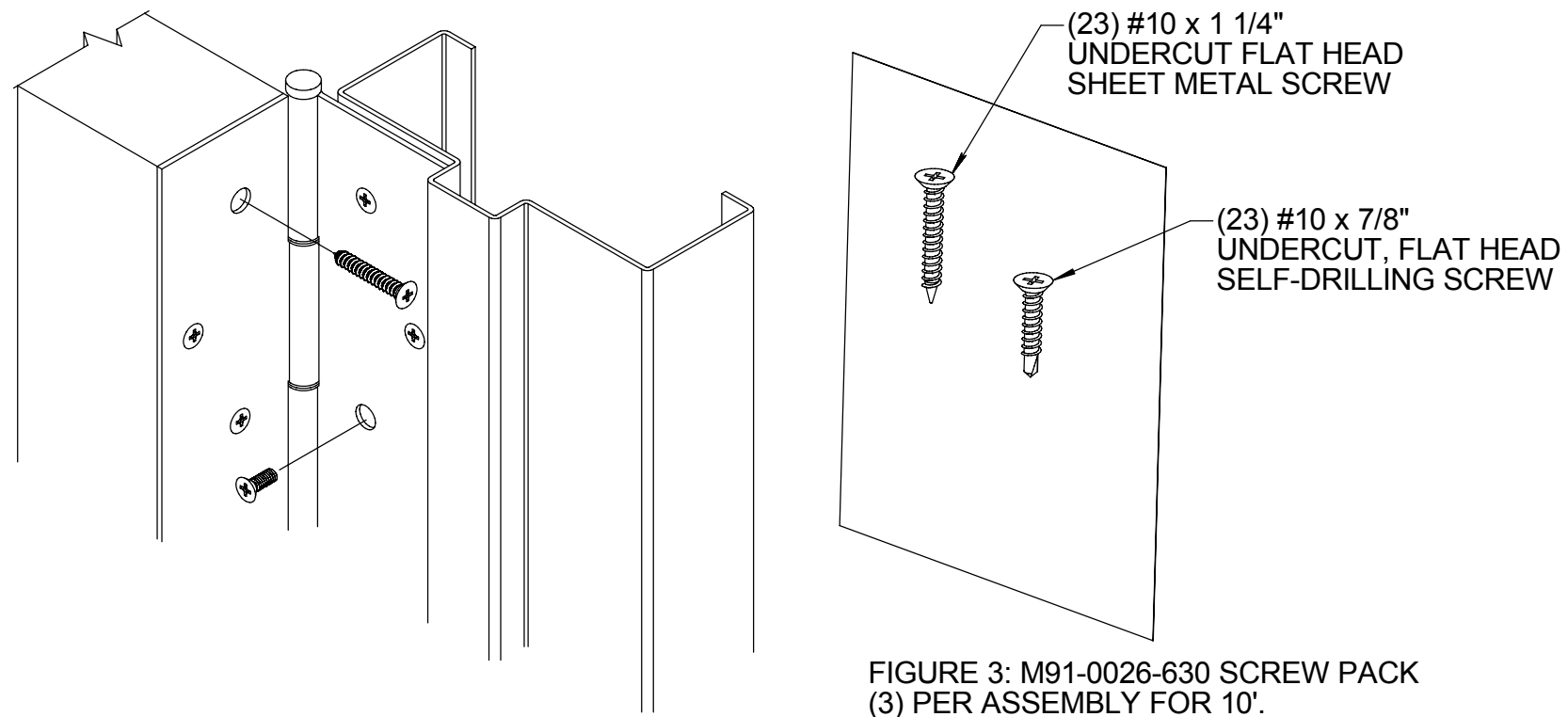
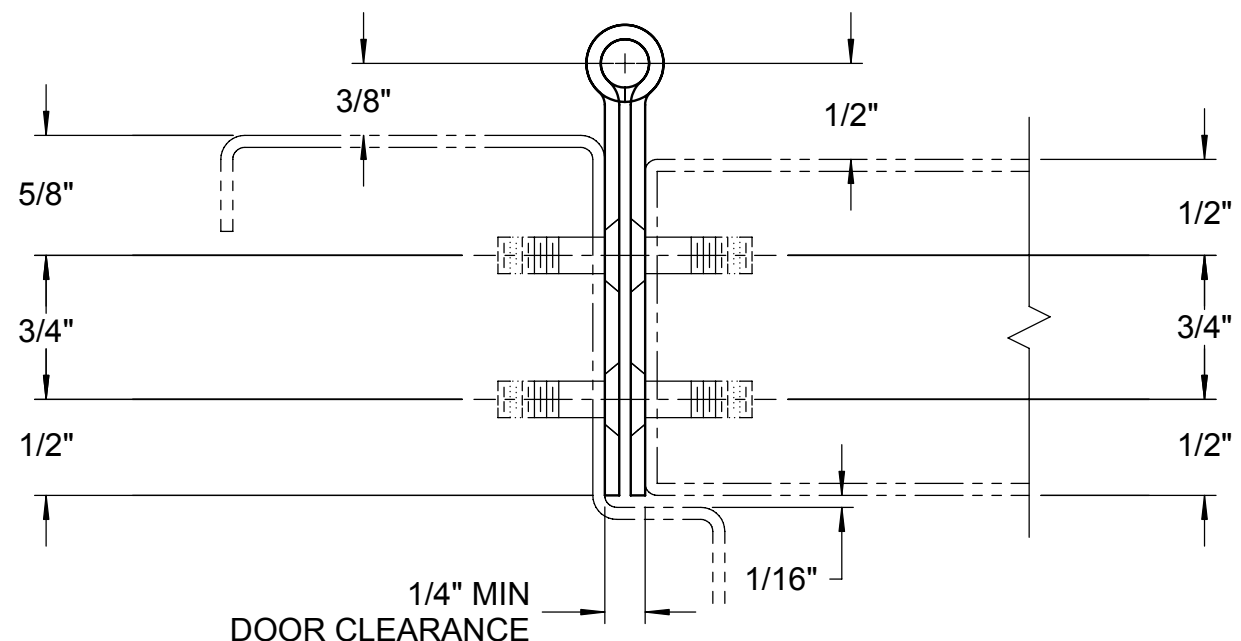

FIGURE 2: INSTALLATION (EXPLODED VIEW)

FIGURE 3: M91-0026-630 SCREW PACK
(3) PER ASSEMBLY FOR 10'.
(2) PER ASSEMBLY ALL OTHERS.



FULL MORTISE HINGE
M80-0180-0300

Rev. B

ECN: M1003

Date: 12-05-06

INSTALLATION INSTRUCTIONS

Page 1 of 1

Appvd:

Date: