

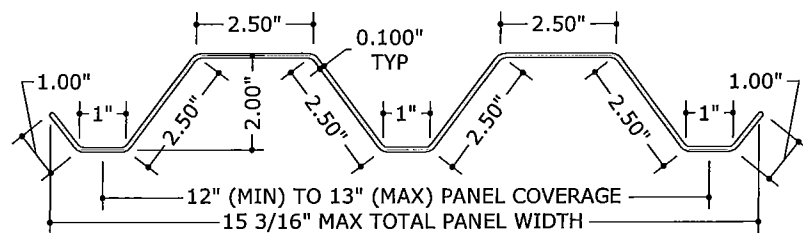

# POLYCARBONATE STORM PANELS (HVHZ)

## GENERAL NOTES:

- THIS SYSTEM HAS BEEN TESTED AND EVALUATED AS A LARGE MISSILE IMPACT PROTECTIVE SYSTEM IN ACCORDANCE WITH THE REQUIREMENTS OF THE 2010 FLORIDA BUILDING CODE PER TAS 201, & 203 TEST PROTOCOLS. PANELS ARE APPROVED FOR USE THROUGHOUT THE STATE OF FLORIDA, INCLUDING WITHIN THE HIGH VELOCITY HURRICANE ZONE (HVHZ) COMPRISED OF MIAMI-DADE & BROWARD COUNTIES.
- NO 33-1/3% INCREASE IN ALLOWABLE STRESS HAS BEEN USED IN THE DESIGN OF THIS PRODUCT.
- POSITIVE AND NEGATIVE DESIGN PRESSURES CALCULATED FOR USE WITH THIS SYSTEM SHALL BE DETERMINED BY OTHERS ON A JOB-SPECIFIC BASIS IN ACCORDANCE WITH THE GOVERNING CODE. SITE-SPECIFIC PRESSURE REQUIREMENTS AS DETERMINED IN ACCORDANCE WITH ASCE 7-10 AND CHAPTER 1609 OF THE 2010 FLORIDA BUILDING CODE SHALL BE LESS THAN OR EQUAL TO THE POSITIVE OR NEGATIVE DESIGN PRESSURE CAPACITY VALUES LISTED HEREIN FOR ANY ASSEMBLY AS SHOWN.
- DESIGN PRESSURES NOTED HEREIN ARE BASED ON MAXIMUM TESTED PRESSURES DIVIDED BY A 1.5 SAFETY FACTOR.
- THE SYSTEM DETAILED HEREIN IS GENERIC AND DOES NOT PROVIDE INFORMATION FOR A SPECIFIC SITE. IF SITE CONDITIONS DEVIATE FROM THE CONDITIONS DETAILED HEREIN, A LICENSED ENGINEER OR REGISTERED ARCHITECT SHALL PREPARE SITE SPECIFIC DOCUMENTS TO BE USED IN CONJUNCTION WITH THIS DOCUMENT.
- THE ADEQUACY OF THE EXISTING STRUCTURE TO WITHSTAND SUPERIMPOSED LOADS IS OUTSIDE THE SCOPE OF THIS CERTIFICATION AND SHALL BE VERIFIED BY OTHERS.
- CLEAR POLYCARBONATE STORM PANELS (FULL, HALF, & DOUBLE-WIDE) MAY VARY IN "COVERAGE" WIDTH UP TO THE RESPECTIVE MAXIMA SHOWN HEREIN, PROVIDED THAT THE PANEL PROFILE HEIGHT BE MAINTAINED. PANELS SHALL BE MOUNTED WITH FASTENERS OR STUDS AT MAXIMUM SPACING SHOWN FOR EACH PROFILE.
- ALL POLYCARBONATE PANELS SHALL BE MANUFACTURED BY TRANSPARENT PROTECTION SYSTEMS, INC.
- THIS PRODUCT APPROVAL IS FOR THE USE OF CLEAR POLYCARBONATE PANELS ONLY. ALL POLYCARBONATE PANELS SHALL BE EXTRUDED WITH THICKNESS  $t=0.100"$  ( $\pm 0.010"$ ) AND SHALL BE MANUFACTURED FROM 100% SYNTHETIC THERMOPLASTIC POLYMER RESIN (UV STABILIZED). ANY PLASTIC MATERIAL TO BE USED IN THE HVHZ MUST DEMONSTRATE COMPLIANCE WITH SECTION 2612 OF THE BUILDING CODE SPECIFIED ABOVE. TYPICAL TENSILE STRENGTH  $F_y=8.908$  KSI, FLEXURAL STRENGTH  $F_{by}=12.90$  KSI, & FLEXURAL MODULUS IS 328.7 KSI.
- ALL EXTRUSIONS SHALL BE 6063-T6 ALUMINUM ALLOY, U.N.O.
- PANELS SHALL BE PERMANENTLY LABELED WITH A MINIMUM OF ONE LABEL PER PANEL CONTAINING THE FOLLOWING:  
TRANSPARENT PROTECTION SYSTEMS, INC.  
WEST PALM BEACH, FLORIDA  
ASTM E330, E1886 & E1996  
PRODUCT APPROVAL NUMBER
- STORM PANELS HAVE BEEN DESIGNED AND TESTED TO THE MAXIMUM SPANS AND CORRESPONDING LOADS SHOWN HEREIN. REFERENCE CONSTRUCTION TESTING CORPORATION (CTC OF MIAMI, FL) TEST REPORTS #04-009-FE-FBC & #04-009-LE-FBC, AS WELL AS HURRICANE TEST LAB (HTL OF RIVIERA BEACH, FL) TEST REPORTS #0239-0107-05, #0239-1013-07, & #0239-0312-06.
- TOP & BOTTOM MOUNTING SECTIONS MAY BE INTERCHANGED AS FIELD CONDITIONS DICTATE. PANELS MAY BE MOUNTED VERTICALLY OR HORIZONTALLY AS APPLICABLE.
- USE OF KEYHOLE WASHERS IS OPTIONAL IN CONJUNCTION WITH ANY MOUNTING CONDITION. HOLES MAY BE FIELD DRILLED IN PANELS AT  $\varnothing 3/8"$  (OR  $\varnothing 5/8"$  WITH KEYHOLE WASHER) WITH ANY FASTENER TYPE. WASHERED WINGNUTS SHALL HAVE 0.865" MINIMUM WASHER DIAMETER.
- ALL BOLTS & WASHERS SHALL BE ZINC COATED STEEL, GALVANIZED STEEL, OR STAINLESS STEEL WITH A MINIMUM TENSILE YIELD STRENGTH OF 60 KSI.



**1 FULL PANEL PROFILE**  
3" = 1'-0" (SEE GEN NOTE 6)

MOUNT WITH FASTENERS OR STUDS AT 13" O.C. MAX

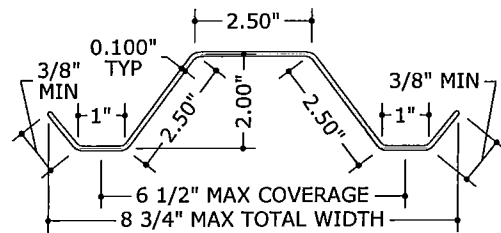

**2 HALF PANEL PROFILE**  
3" = 1'-0" (SEE GEN NOTE 6)

MOUNT WITH FASTENERS OR STUDS AT 6-1/2" O.C. MAX

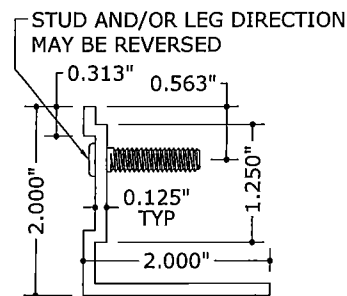

**3 STUD ANGLE**  
6" = 1'-0"

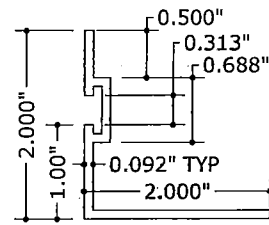

**4 REVERSE 'F' ANGLE**  
6" = 1'-0"

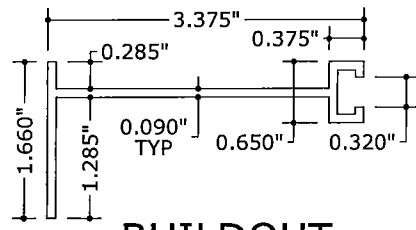

**5 BUILDOUT 'F' TRACK**  
6" = 1'-0"

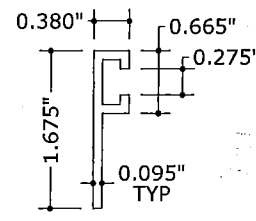

**6 'F' TRACK**  
6" = 1'-0"

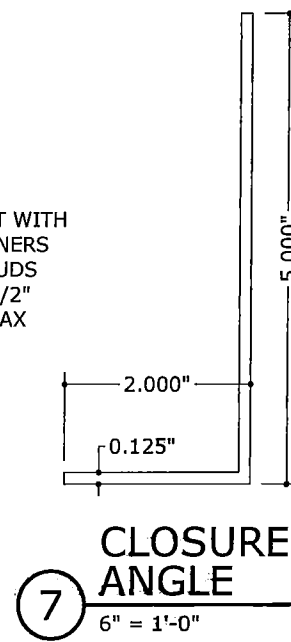

**7 CLOSURE ANGLE**  
6" = 1'-0"

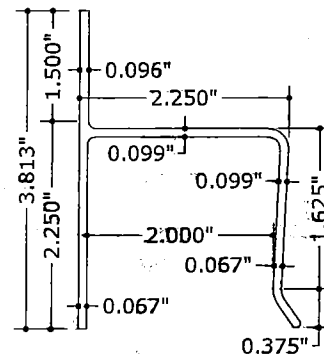

**8 KEYHOLE WASHER**  
6" = 1'-0"

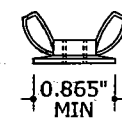

**9 WASHERED WINGNUT**  
6" = 1'-0"

**10 'H' HEADER**  
6" = 1'-0"

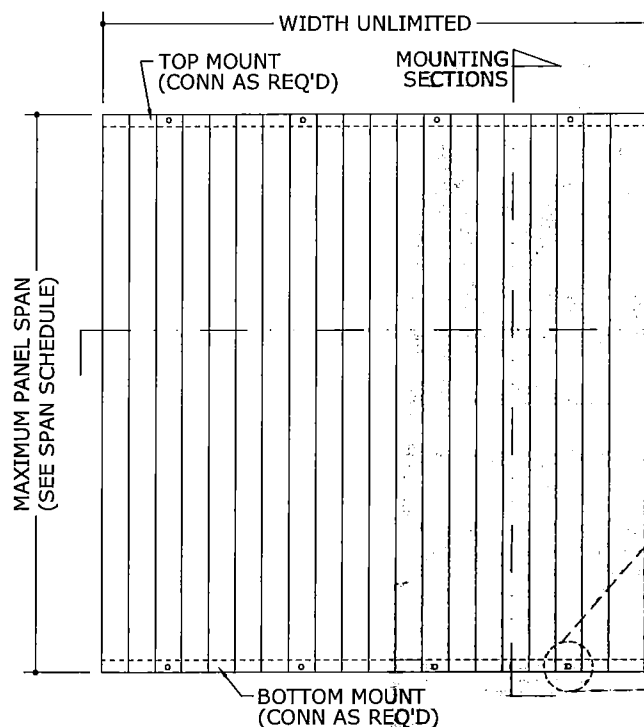

**1 TYPICAL ELEVATION**  
1 N.T.S.

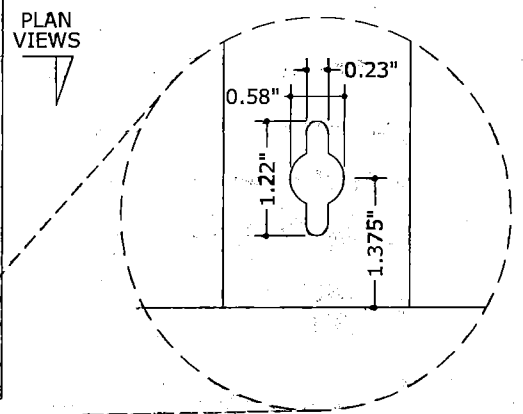

**2 KEYHOLE DETAIL**  
1 N.T.S. ALT: FIELD DRILL  $\varnothing 3/8"$  HOLE (OR  $\varnothing 5/8"$  HOLE W/ KEYHOLE WASHER)

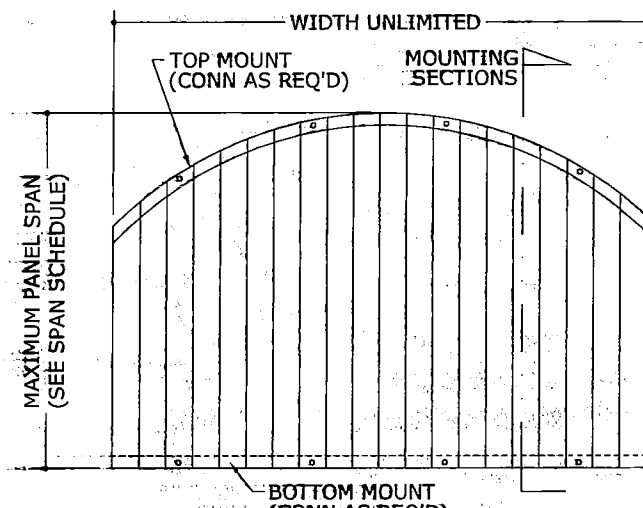

**3 ALT. ARCH TOP\***  
1 N.T.S.

\*NOTE: FOR ALTERNATE ARCH TOP INSTALLATIONS, THE TOP TRACK OR U-HEADER SHALL BE CUT INTO 6" MINIMUM ADJACENT SEGMENTS. EACH SEGMENT SHALL HAVE ANCHORS SPACED PER THE ANCHOR SCHEDULE, WITH A MINIMUM OF (2) ANCHORS PER SEGMENT. ANCHORS SHALL BE 1-1/2" MIN FROM ENDS OF EACH SEGMENT AND SPACED 3" MINIMUM FROM ADJACENT ANCHORS. FOR STUDDED TRACKS ONLY, THERE SHALL BE A MINIMUM OF (1) STUD PER SEGMENT FASTENED TO THE STORM PANEL. STUDS SHALL BE LOCATED 2" MINIMUM FROM ENDS OF EACH SEGMENT.

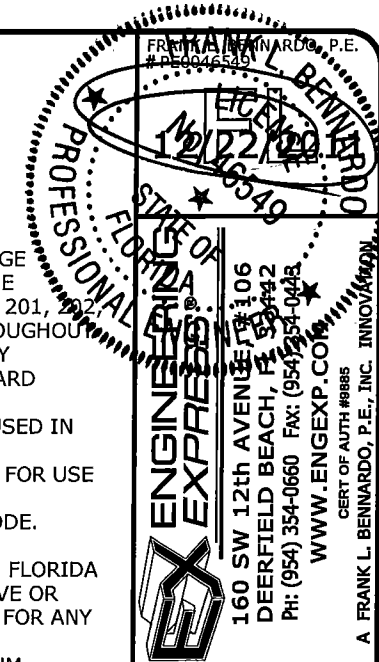

**TPS** Transparent Protection Systems, Inc.  
6643 42nd Terrace North  
West Palm Beach, FL 33407  
FOR USE WITHIN AND OUTSIDE THE HVHZ  
FLORIDA STATEWIDE APPROVAL

REMARKS	DATE	DRWN	CHKD
2004 FBC	8/17/04	CL	FLB
2007 FBC	8/5/05	CL	FLB
2010 FBC UPDATE	2/6/06	CL	FLB
2010 FBC UPDATE	2/6/06	EFT	KL
12/12/11			

COPYRIGHT FRANK L. BENARDO P.E.

**08-TPS-0007**

SCALE: 1/4"

PAGE DESCRIPTION:

1 of 5

12/22/2011 - 9:59am keithl F:\01 Project Files\Transparent Protection (TPS)\2008\06-TPS-0007 ClearGuard Polycarbonate Storm Panels HVHZ (FSA)\_04.FBC 2010 Update\TPS-0007\_04c ClearGuard Polycarbonate Storm Panels HVHZ (FSA).dwg

12/22/2011 - 9:58am keithl F:\01 Project Files\Transparent Protection (TPS)\2008\08-TPS-0007 ClearGuard Polycarbonate Storm Panels, HVHZ (FSA)\_04 FBC 2010 Up08-TPS-0007\_04c ClearGuard Polycarbonate Storm Panels, HVHZ (FSA).dwg

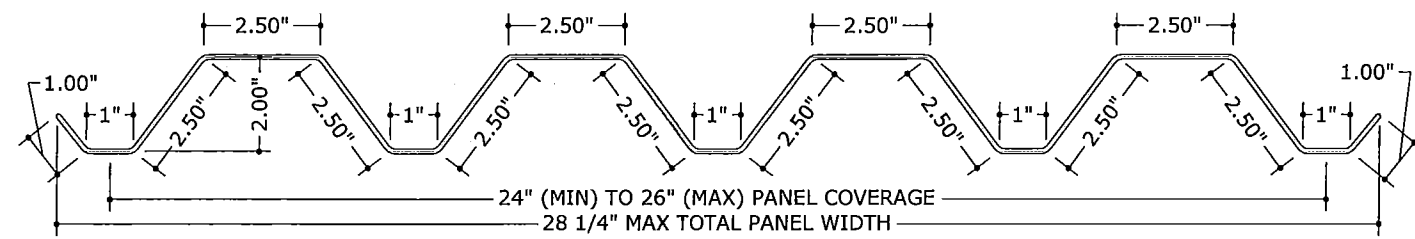

**11** "CLEARMAX™" DOUBLE-WIDE PANEL PROFILE  
3" = 1'-0" (SEE GEN NOTE 6)

MOUNT WITH FASTENERS OR STUDS AT 13" O.C. MAX

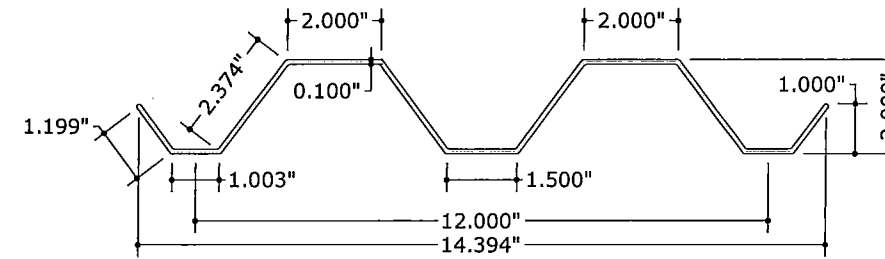

**12** ALT. FULL PANEL PROFILE  
N.T.S. (SEE GEN NOTE 6)

MOUNT WITH FASTENERS OR STUDS AT 13" O.C. MAX

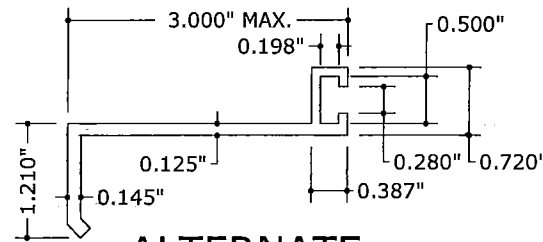

**13** ALTERNATE B.O. 'F' TRACK  
6" = 1'-0"

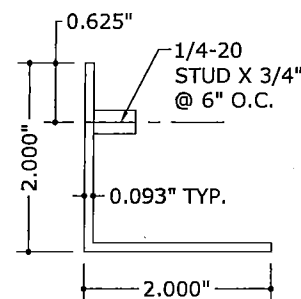

**14** ALTERNATE STUD ANGLE  
6" = 1'-0"

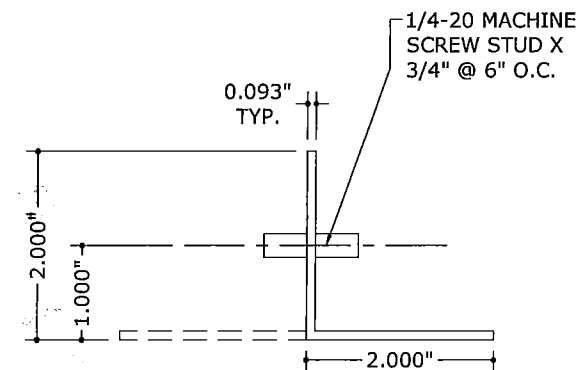

**15** STUDED ANGLE  
6" = 1'-0"

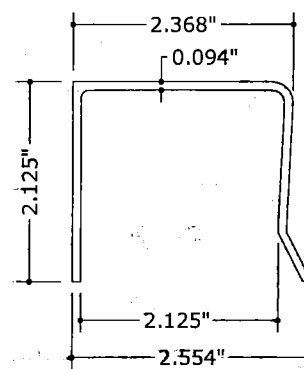

**16** U-HEADER  
N.T.S. 6063-T6

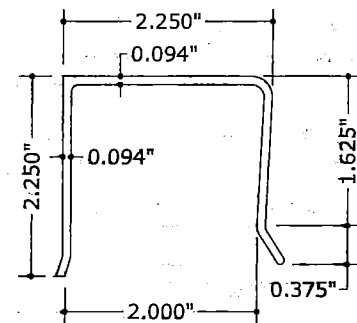

**17** ALTERNATE U-HEADER  
N.T.S. 6063-T6

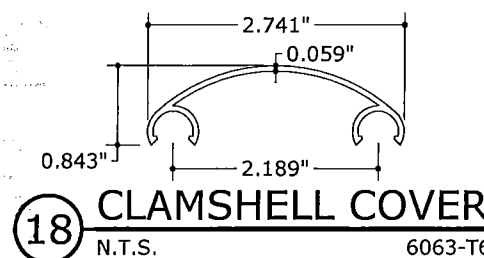

**18** CLAMSHELL COVER  
N.T.S. 6063-T6

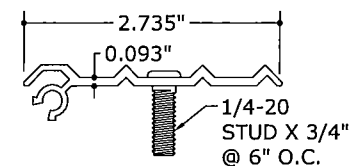

**19** CLAMSHELL TRACK  
N.T.S. 6063-T6

FRANK L. BENNARDO, P.E.  
PROFESSIONAL ENGINEER  
STATE OF FLORIDA  
ENGINEERING EXPERTS, INC.  
160 SW 12th Avenue, #106  
Deerfield Beach, FL 33442  
PH: (954) 354-0660 FAX: (954) 354-0443  
WWW.ENGEXP.COM  
CERT OF AUTH #9885  
A FRANK L. BENNARDO, P.E., INC. INNOVATION

Transparent Protection Systems, Inc.  
6643 42nd Terrace North  
West Palm Beach, FL 33407  
CLEARGUARD POLYCARBONATE STORM PANELS  
FOR USE WITHIN AND OUTSIDE THE HVHZ  
FLORIDA STATEWIDE APPROVAL

DRWN	CHKD	DATE
CL	FLB	8/17/04
CL	FLB	8/5/05
CL	FLB	2/6/06
EFT	KL	12/12/11

REMARKS: 2004 FBC, 2007 FBC, 2010 FBC UPDATE. THIS DOCUMENT IS THE PROPERTY OF FRANK L. BENNARDO, P.E. REPRODUCTION OR TRANSMISSION OF THIS DOCUMENT WITHOUT WRITTEN CONSENT OF FRANK L. BENNARDO, P.E. IS PROHIBITED. ANY ALTERATIONS, ADDITIONS, DELETIONS OR OTHER HANDS TO THIS DOCUMENT ARE NOT PERMITTED AND INVALIDATE OUR CERTIFICATION.

COPYRIGHT FRANK L. BENNARDO P.E.

08-TPS-0007  
SCALE: 04  
PAGE DESCRIPTION:  
2 of 5

12/22/2011 - 9:59am keithl F:\01 Project Files\Transparent Protection (TPS)\2008\08-TPS-0007 ClearGuard Polycarbonate Storm Panels, HVHZ (FSA).dwg 04 FBC 2010 Up08-TPS-0007\_04c ClearGuard Polycarbonate Storm Panels, HVHZ (FSA).dwg

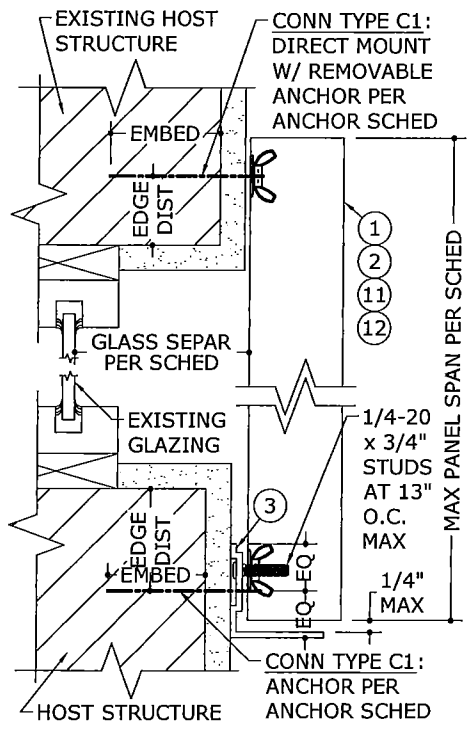

**1** MOUNTING SECTION  
3" = 1'-0" VERT SECTION

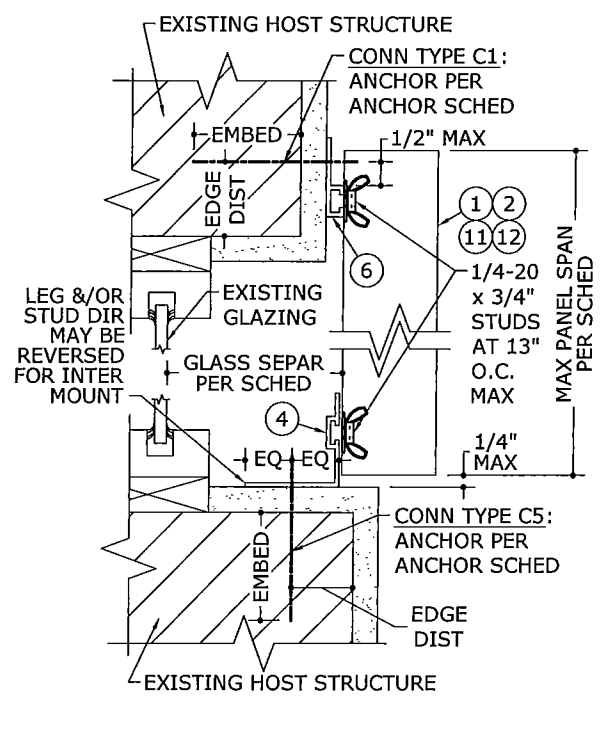

**2** MOUNTING SECTION  
3" = 1'-0" VERT SECTION

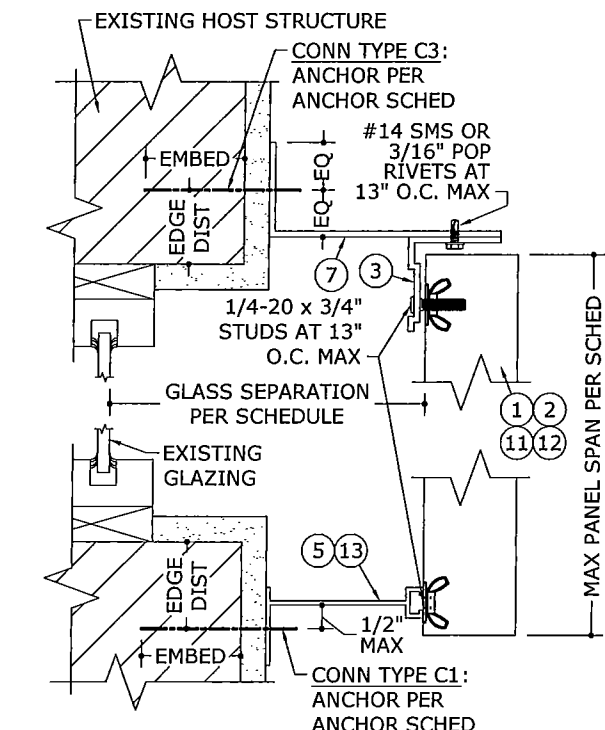

**3** MOUNTING SECTION  
3" = 1'-0" VERT SECTION

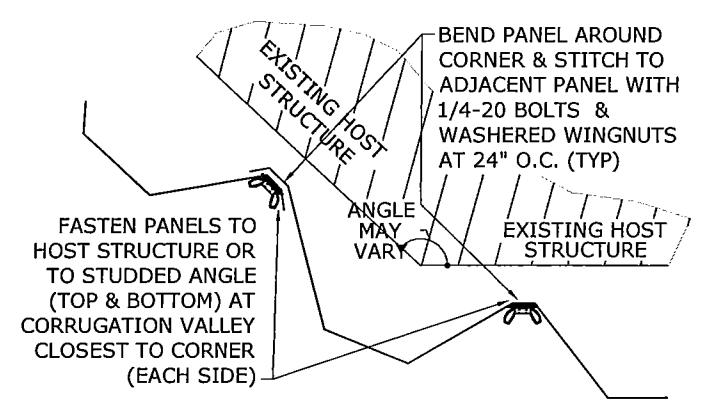

**5** CORNER CLOSURE  
3" = 1'-0" PLAN VIEW

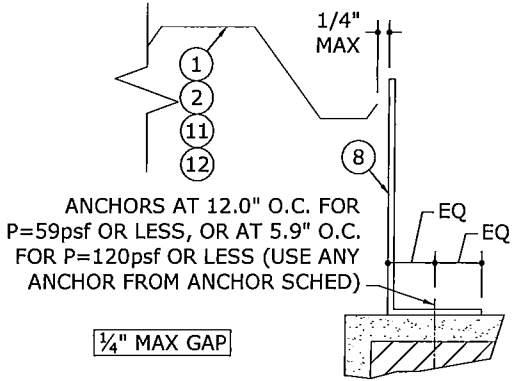

**6** BUILD-OUT CLOSURE  
3" = 1'-0" PLAN VIEW

NOTE: DETAIL 9/3 MAY BE USED AS AN ALTERNATE TO CLOSURE DETAILS 7/3 AND 6/3.

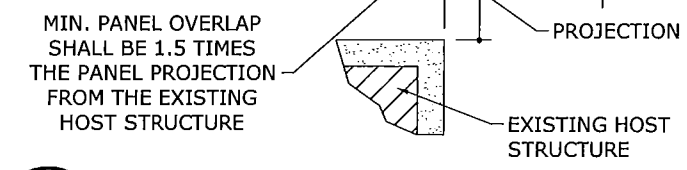

**9** PANEL OVERLAP  
3" = 1'-0" PLAN VIEW

**MAXIMUM PANEL SPAN SCHEDULE (POSITIVE CONN.)**

LOAD (psf)	MAX SPAN (ft)
±25	6'-5"
±30	6'-2"
±32	6'-1"
±35	5'-11"
±40	5'-9"
±45	5'-7"
±50	5'-5"
±55	5'-3"
±60	5'-2"
±65	5'-1"
±70	5'-0"
±75	4'-10"
±80	4'-9"
±90	4'-7"
±100	4'-4"
±110	3'-11"
±120	3'-7"

**MAXIMUM SPAN SCHEDULE NOTES:**

1. SPANS SHOWN IN "MAX PANEL SPAN SCHEDULE" ABOVE ARE MAXIMUM ALLOWABLE SPANS AT EACH RESPECTIVE DESIGN PRESSURE.
2. THIS SCHEDULE MAY BE USED TO DETERMINE MAXIMUM ALLOWABLE SPANS FOR PANELS INSTALLED USING ANY COMBINATION OF MOUNTING EXTRUSIONS INVOLVING A POSITIVE CONNECTION - i.e. ALL INSTALLATIONS WHICH DO NOT INCLUDE AN "H" OR "U" HEADER.
3. WHERE THE "H" HEADER IS USED, THE MAXIMUM ALLOWABLE SPAN IS 5'-0" (60") AND THE MAXIMUM ALLOWABLE PRESSURE IS 55.47psf.
4. WHERE "U" HEADER IS USED, THE MAXIMUM ALLOWABLE SPAN IS 4'-4" (52") AND THE MAXIMUM ALLOWABLE PRESSURE IS +78/-80 PSF.
5. TABLE ABOVE IS VALID FOR PANELS MOUNTED HORIZONTALLY OR VERTICALLY. SPAN DIRECTION IS ALWAYS PERPENDICULAR TO LINE OF ANCHORAGE.

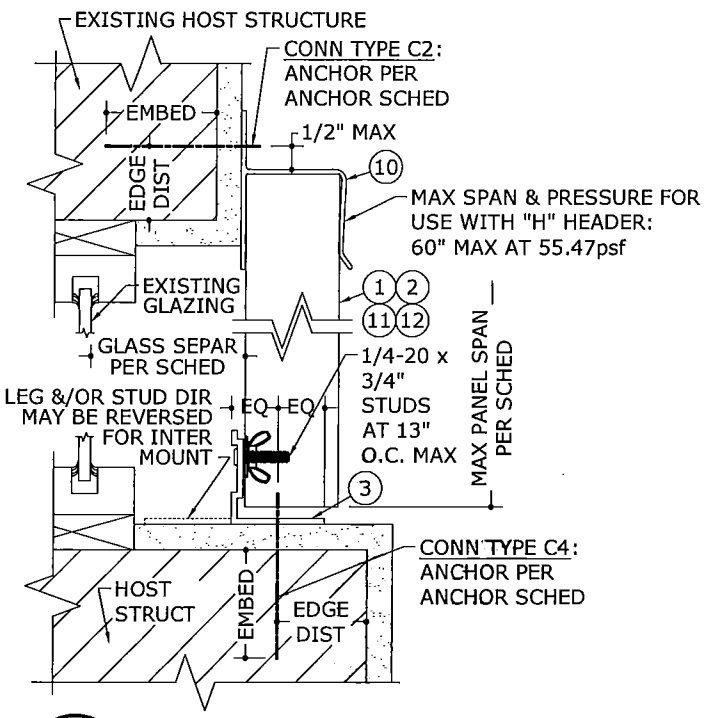

**4** MOUNTING SECTION  
3" = 1'-0" VERT SECTION

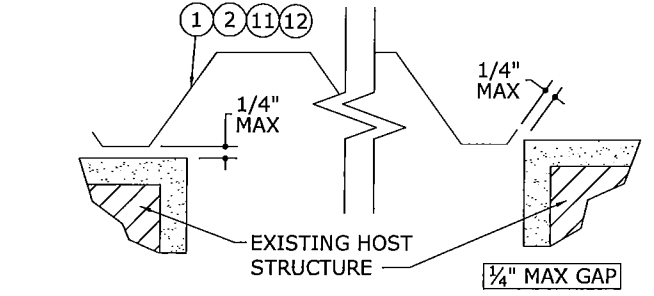

**7** WALL MOUNT CLOSURE  
3" = 1'-0" PLAN VIEW

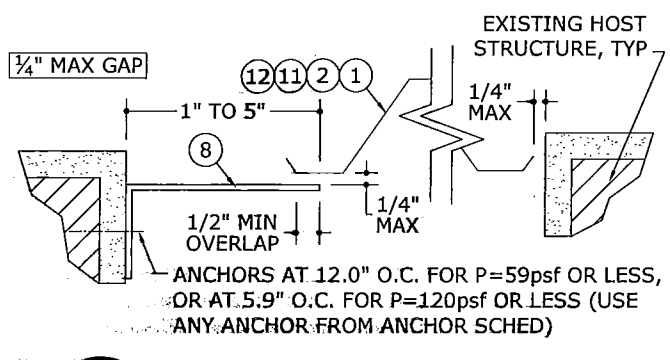

**8** TRAP MOUNT CLOSURE  
3" = 1'-0" PLAN VIEW

**FRANK L. BENNARDO, P.E.**  
PROFESSIONAL ENGINEER  
STATE OF FLORIDA  
12/22/2011

**TPS ENGINEERING EXPRESS**  
160 SW 12th Avenue, Suite 106  
Deerfield Beach, FL 33442  
PH: (954) 354-0660 FAX: (954) 354-0443  
WWW.ENGEXP.COM  
CERT OF AUTH #9885  
A FRANK L. BENNARDO, P.E., INC. INNOVATION

**TPS**  
Transparent Protection Systems, Inc.  
6643 42nd Terrace North  
West Palm Beach, FL 33407

CLEARGUARD POLYCARBONATE STORM PANELS  
FOR USE WITHIN AND OUTSIDE THE HVHZ  
FLORIDA STATEWIDE APPROVAL

DRWN	CHKD	DATE
CL	FLB	8/17/04
CL	FLB	8/5/05
CL	FLB	2/6/06
CL	FLB	2/6/06
KL	FLB	12/12/11

REMARKS: 2004 FBC, 2007 FBC, 2010 FBC UPDATE. THIS DOCUMENT IS NOT PERMITTED AND INVALIDATE OUR CERTIFICATION.

COPYRIGHT FRANK L. BENNARDO P.E.

**08-TPS-0007**

SCALE: 1/4" = 1'-0"

PAGE DESCRIPTION:

3 OF 5

F:\01 Project Files\Transparent Protection (TPS)\2008\08-TPS-0007 ClearGuard Polycarbonate Storm Panels, HVHZ (FSA).dwg

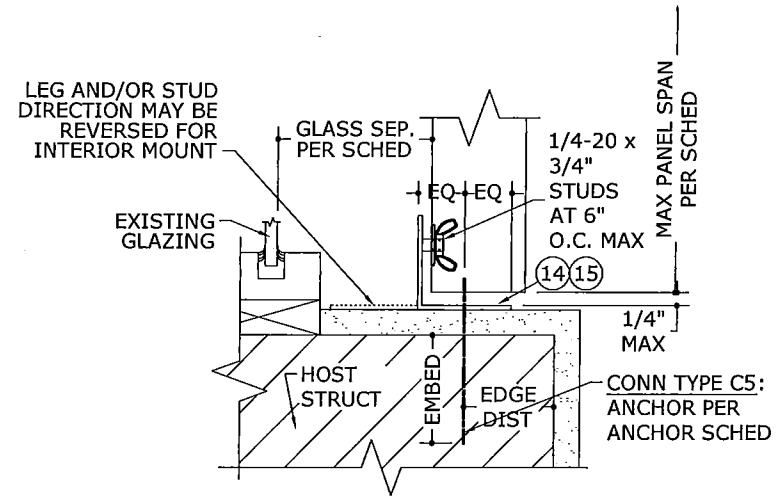

**1** MOUNTING SECTION  
**4** 3" = 1'-0" VERT SECTION

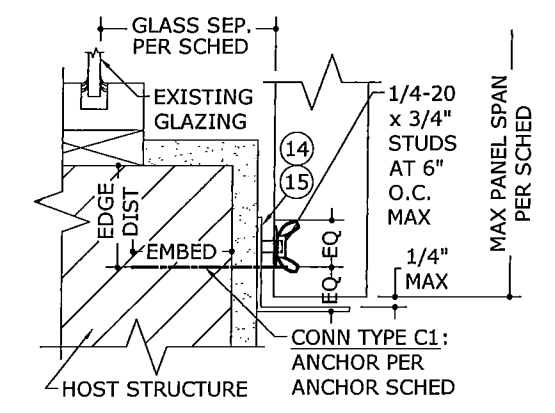

**2** MOUNTING SECTION  
**4** 3" = 1'-0" VERT SECTION

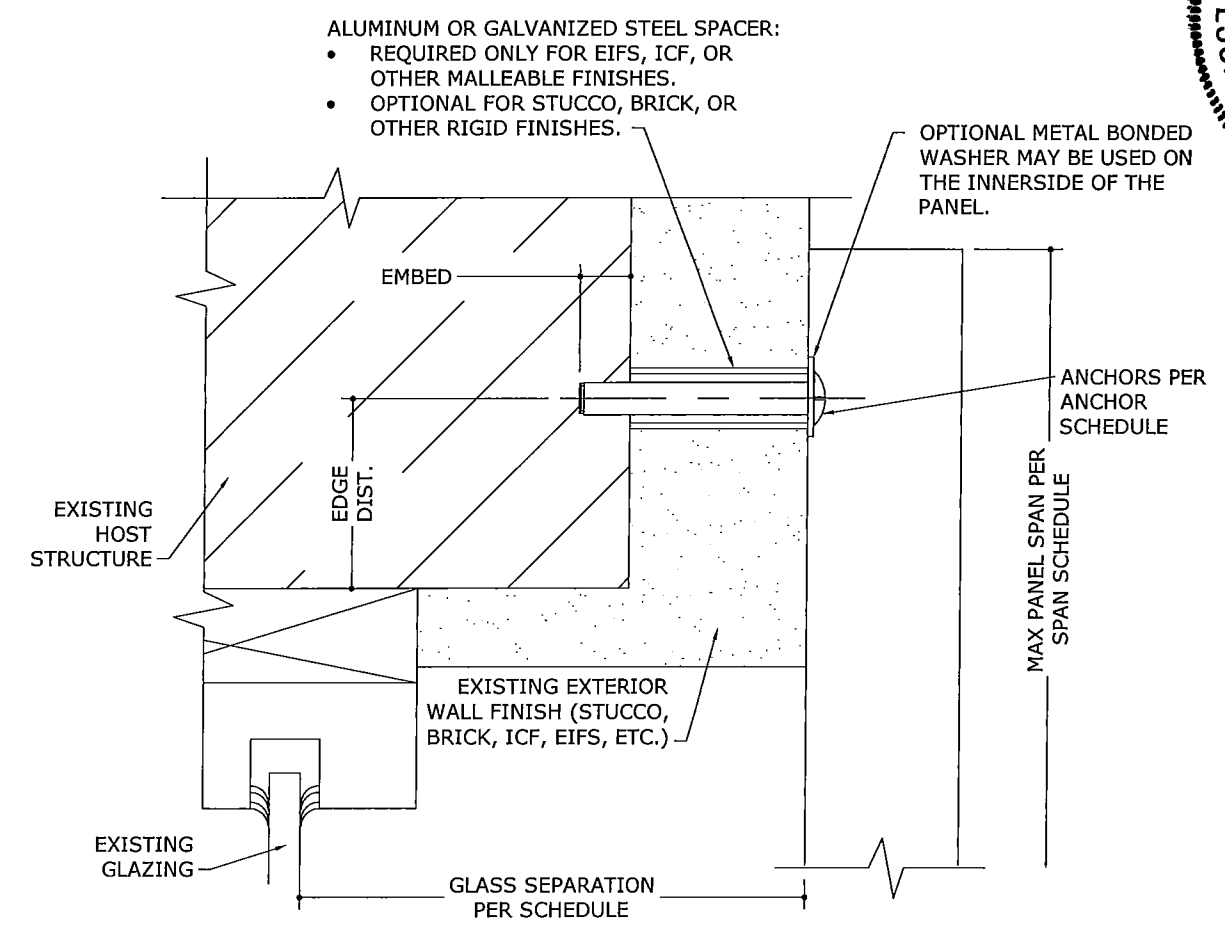

NOTE: SHUTTER SYSTEM MAY BE ANCHORED THROUGH EXTERIOR WALL FINISH TO HOST STRUCTURE WITH ANY MOUNTING CONDITION SHOWN HEREIN.

**5** MOUNTING SECTION THRU EXTERIOR WALL FINISH (BRICK, ICF, EIFS, ETC.)  
**4** N.T.S. VERT SECTION

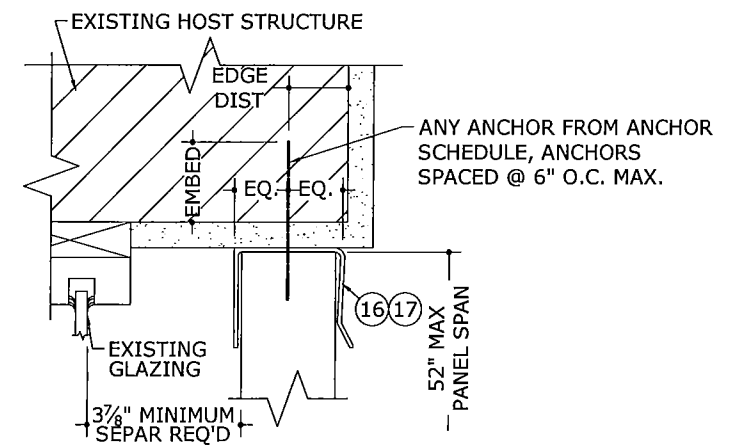

NOTE: MAXIMUM SPAN AND PRESSURE FOR USE WITH 'U' HEADERS: 52" MAX PANEL SPAN, +78/-80 PSF MAX DESIGN PRESSURE

**3** MOUNTING SECTION  
**4** N.T.S. VERT SECTION

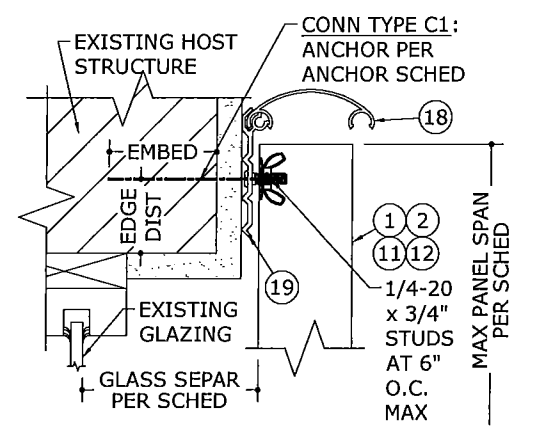

**4** MOUNTING SECTION  
**4** N.T.S. VERT SECTION

FRANK L. BENNARDO, P.E.  
 #12922  
 12/22/11  
 PROFESSIONAL ENGINEER  
 STATE OF FLORIDA

**ENGINEERING EXPRESS**

160 SW 12th Avenue, #1106  
 Deerfield Beach, FL 33442  
 Ph: (954) 354-0660 Fax: (954) 354-9448  
 WWW.ENGEXP.COM  
 CERT OF AUTH #9885  
 A FRANK L. BENNARDO, P.E., INC. INNOVATION

**TPS** Transparent Protection Systems, Inc.  
 6643 42nd Terrace North  
 West Palm Beach, FL 33407

CLEARGUARD POLYCARBONATE STORM PANELS  
 FOR USE WITHIN AND OUTSIDE THE HVHZ  
 FLORIDA STATEWIDE APPROVAL

REMARKS	DRWN	CHKD	DATE
ORIG ISSUE	CL	FLB	8/17/04
2004 FBC	CL	FLB	8/15/05
ClearMAX PROFILE ADDED	CL	FLB	2/6/06
2007 FBC	KL	FLB	2/6/06
2010 FBC UPDATE	EFT	KL	12/12/11

THIS DOCUMENT IS THE PROPERTY OF FRANK L. BENNARDO, P.E. AND SHALL BE REPRODUCED IN WHOLE OR PART WITHOUT WRITTEN CONSENT OF FRANK L. BENNARDO, P.E. ALTERATIONS, ADDITIONS, MODIFICATIONS, OR OTHER MARKINGS TO THIS DOCUMENT ARE NOT PERMITTED AND INVALIDATE OUR CERTIFICATION.

COPYRIGHT FRANK L. BENNARDO P.E.

**08-TPS-0007**

SCALE: **04**

PAGE DESCRIPTION:

**4** of **5**

