

# CERTIFIED TESTING LABORATORIES

Architectural Division • 7252 Narcoossee Rd. • Orlando, FL 32822  
(407) 384-7744 • Fax (407) 384-7751  
Web Site: www.ctlarch.com  
E-mail: ctlarch.com

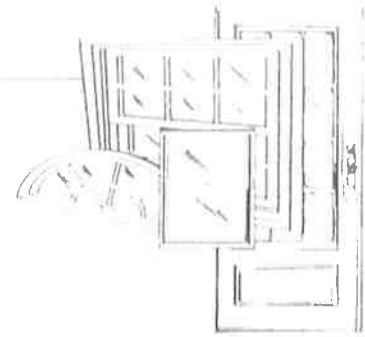

**Report No.:** CTLA 2037W-2  
**DC Not. No.:** CTL 10011  
**CTL Certification #:** 08-0528.05

**Date:** June 28, 2010  
**Test Dates:** June 21<sup>st</sup> - 26<sup>th</sup>, 2010

**Test Requested By:** Ingersoll Rand  
9017 Blue Ash Rd.  
Cincinnati, Ohio 45242

**Tests Conducted:** TAS 201 (Lg. Missile), TAS 202 (with deviations, no water test) & TAS 203

**Design Pressures:**

Specimen 1	(TAS 202) - Outswing	+ 80.0 psf.	- 60.0 psf.
Specimen 2	(TAS 202) - Inswing	+ 60.0 psf.	- 80.0 psf.
Specimen 3 & 4	(TAS 201, TAS 203)	+ 70.0 psf.	- 70.0 psf.

## (1) DESCRIPTION OF SERIES

**Model Designation:** SZ Series 3070 Steel Commercial Flush Door, 18 gauge  
**Overall Size:** All Specimens - (Frame) 40.00" wide x 86.00" high x 5.75" deep.  
**Configuration:** All Specimens - X  
**No. & Size of Panels:** All Specimens - (1) Slab 35.79" wide x 83.19" high.

## (2) MATERIAL CHARACTERISTICS

**Frame Material:**  
All Specimens ASTM A-366 16 Ga. Steel, cold rolled as stated by manufacturer

**Frame Construction:**  
All Specimens Cold rolled steel measuring 2.0" wide face x 5.75" deep x 4.875" throat opening. Mitered corner tab and slot construction. Extruded aluminum threshold measuring 0.500" high x 5" wide x 36" long coped to fit into main frame and secured with three (3) #12 x 1.50" wood screws.

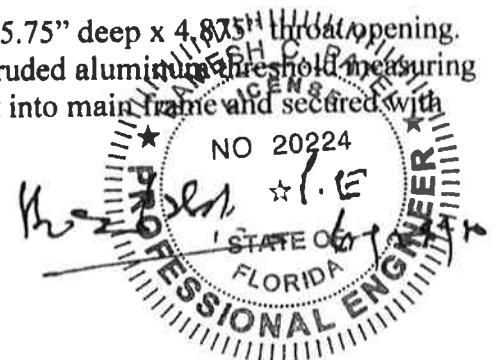

**Slab Construction:**

All Specimens

Single slab measure 35.79" x 83.19" x 1.75". 18 Ga. Galvanized steel skins. Polystyrene core laminated to both inside faces. Vertical edges square with a continuous mechanical seam. Top and bottom rails contained 16 GA. steel channels measuring .688" x 1.660" x 35.66" long, spot welded to face sheets nominally 2" from each end and 6" on center thereafter. Lock reinforcement is 14 Ga. and 8 Ga. hinge reinforcements.

**Glazing:**

N/A

**Weather-stripping:**

All Specimens

<u>QTY</u>	<u>DESCRIPTION</u>	<u>LOCATION</u>
One (1) Strip	PS-074 Weather-strip	Frame Head
One (1) Strip	PS-074 Weather-strip	Frame Jambs
One (1) Strip	Bulb vinyl bumper basket .250" o.d.	Length of threshold
One (1) piece	Fas-seal door sweep two (2) fin	Slab bottom

**Hardware:**

All Specimens

<u>QTY</u>	<u>DESCRIPTION</u>	<u>LOCATION</u>
Three (3)	Ives 5BB1 hinges 4.5" x 4.5" x .134" thick with four (4) .210" dia. X .525" self threading Phillips head countersunk screws to frame and four (4) Phillips head countersunk screws to the leaf.	Three in each frame jamb measuring from rabbet in head to center of hinge at 9.75", 41.69" and 73.625"
Six (6)	Wire hinge spacer.	One behind each hinge on door leaf.
One (1)	Falcon T series, Grade 1, cylindrical lock 1/2" latch throw.	Door Slab
One (1)	National Guard 950A Threshold w/bumper.	Frame Sill.

**Reinforcement:**

All Specimens

<u>QTY</u>	<u>DESCRIPTION</u>	<u>LOCATION</u>
One (1)	Cylindrical lock reinforcement, 14 GA galvanized steel	Door leaf lock stile
Three (3)	Hinge reinforcement, 8 GA galvanized steel measuring 1.25" x 8" long.	Door leaf hinge stile
Three (3)	Hinge reinforcement, 7 GA steel measuring 1.23" x 9.19" long.	Frame hinge jamb

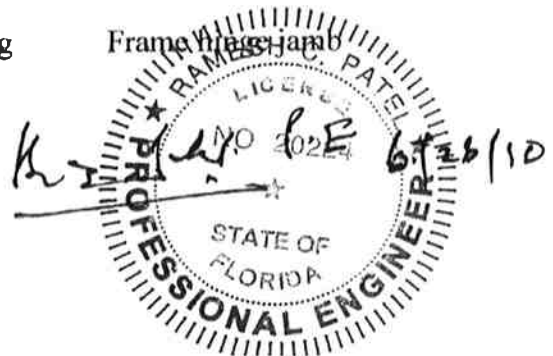

**Weep holes:** N/A

**Sealant:**  
All Specimens Latex caulking as needed to seal unit into rough opening.

**INSTALLATION:**

**Screws and Method of Attachment:**

All Specimens Specimens were tested in wooden test buck, installed with eight (8) 3/8 x 4" lag bolts (4 per jamb) and three (3) #12 x 1.50" wood screws.  
Head: None  
Sill: Three (3) #12 x 1.5" wood screws located 6.5", 18", 29.5"  
Jambs: Eight (8) 3/8" x 4" lag bolts. Four (4) in each Jamb, located measuring from bottom to top at 4", 19.97", 51.9", and 80.1"

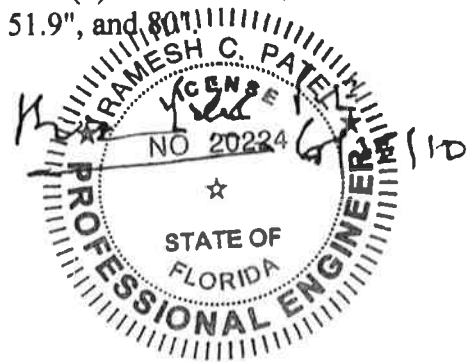

**Performance Test Results**

**Test Sequence: TAS 202**

- |                                |              |
|--------------------------------|--------------|
| 1. Air Infiltration            | ASTM 283-91  |
| 2. ½ Test Pressure Positive    | ASTM E330-02 |
| 3. ½ Test Pressure Negative    | ASTM E330-02 |
| 4. Design Pressure Positive    | ASTM E330-02 |
| 5. Design Pressure Negative    | ASTM E330-02 |
| 6. Full Test pressure Positive | ASTM E330-02 |
| 7. Full Test Pressure Negative | ASTM E330-02 |

**Deflection Gauges locations**

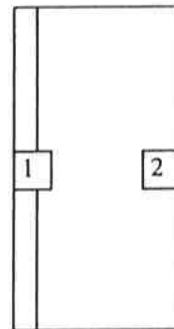

Deflection was measured with two (2) 5” CDI Dial Indicators  
 Location #1 2” above lock. Location # 2 Mid-span of fasteners in jamb.

**X**

**AIR INFILTRATION**

Air Infiltration Tests were conducted in accordance with **TAS 202-94**

Air @ 1.57 psf.	<u>Actual</u>	<u>Allowable</u>
Specimen 1	.13 cfm/ft <sup>2</sup>	.34 cfm/ft <sup>2</sup>
Specimen 2	.14 cfm/ft <sup>2</sup>	.34 cfm/ft <sup>2</sup>

**STATIC AIR PRESSURE TESTS**

Static Tests were conducted in accordance with **TAS 202-94**

**Specimen 1 - Outswing**

<u>Range of test</u>	<u>Time (Sec.)</u>	<u>Load (psf.)</u>	<u>Loc.</u>	<u>Deflection</u>	<u>Perm. Set</u>	<u>Allowable</u>
<b>Positive loads</b> (Design Pressure + 80.0 psf.)						
1/2 Test	30	60				
Design	30	80	Loc. 1	0.286”		
			Loc. 2	0.149”		
Test	30	120	Loc. 1		0.022”	0.333”
			Loc. 2		0.041”	0.128”
<b>Negative loads</b> (Design Pressure – 60.0 psf.)						
1/2 Test	30	45				
Design	30	60	Loc. 1	0.322”		
			Loc. 2	0.087”		
Test	30	90	Loc. 1		0.140”	0.333”
			Loc. 2		0.014”	0.128”

**All Permanent set numbers are gross numbers**

Location (1) - Max. allowable Perm. Set after test load (0.4% of 83.25” span) = 0.333”

Location (2) - Max. allowable Perm. Set after test load (0.4% of 32.0” span) = 0.128”

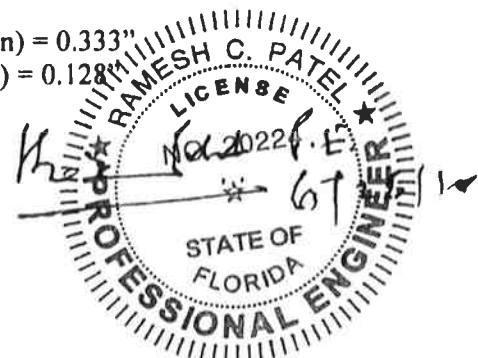

**Performance Test Results (Continued)**

**STATIC AIR PRESSURE TESTS (Continued)**

**Specimen 2 - Inswing**

<u>Range of test</u>	<u>Time (Sec.)</u>	<u>Load (psf.)</u>	<u>Loc.</u>	<u>Deflection</u>	<u>Perm. Set</u>	<u>Allowable</u>
<b>Positive loads</b> (Design Pressure + 60.0 psf.)						
1/2 Test	30	60				
Design	30	80	Loc. 1	0.336"		
			Loc. 2	0.091"		
Test	30	120	Loc. 1		0.145"	0.333"
			Loc. 2		0.015"	0.128"
<b>Negative loads</b> (Design Pressure – 80.0 psf.)						
1/2 Test	30	45				
Design	30	60	Loc. 1	0.275"		
			Loc. 2	0.145"		
Test	30	90	Loc. 1		0.023"	0.333"
			Loc. 2		0.042"	0.128"

**All Permanent set numbers are gross numbers**

Location (1) - Max. allowable Perm. Set after test load (0.4% of 83.25" span) = 0.333"

Location (2) - Max. allowable Perm. Set after test load (0.4% of 32.0" span) = 0.128"

<u>Specimen</u>	<u>Title of Test</u>	<u>Method</u>	<u>Result</u>	<u>Load</u>
Specimen 1	Forced Entry Resistance Load peak was 30 seconds	AAMA 1304 -02	Passed	300 lbs
Specimen 2	Forced Entry Resistance Load peak was 30 seconds	AAMA 1304 -02	Passed	300 lbs

**Note: At the conclusion of testing, there was no opening thru which access to the interior hardware, or locking devices could be gained. In addition there was no opening which allowed for entrance into the specimen tested. The leaf remained locked, closed and no locks or hinges disengaged.**

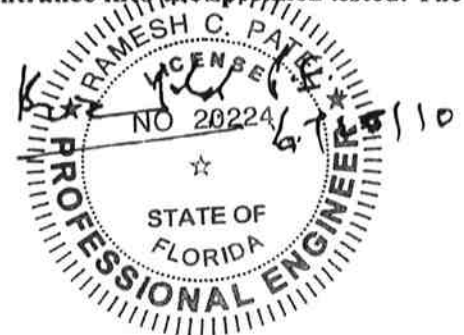

**Performance Test Results (Continued)**

**Impact Test: Large Missile**

Impact tests were conducted in accordance with TAS 201-94

Each specimen was impacted with an 8 ft., 9 lb. Southern yellow pine 50mm x 100mm (2" x 4") at the following locations:

**Note: Specimen 3 (Outswing) & 4 (Inswing)**

X measurement from left edge of specimen.

Y measurement from top edge of test specimen.

Type and weight of missile: # 2 Southern Yellow Pine 2x4, Length approx. 89-5/16" & 9 lb.

**Specimen 3**

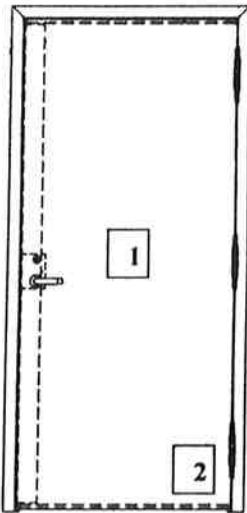

**Specimen 4**

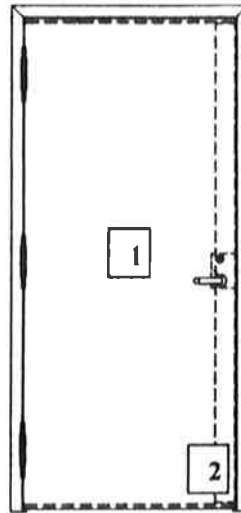

Specimen #	Impact No.	Speed Ft/Sec.	X Meas.	Y Meas.
3	1	49.7	20.00"	41.50"
3	2	49.5	33.50"	75.00"
4	1	49.3	20.00"	42.00"
4	2	50.1	33.00"	76.00"

**Result:** None of the impacts penetrated the specimen.



**Performance Test Results (Continued)**

**Fatigue Loading Test**

Cycle tests were conducted in accordance with TAS 203

**Specimen 3 & 4**

**Positive loads**

**Design Pressure + 70.0 psf.**

<u>Range of Test</u>	<u>Actual Load (psf.)</u>	<u># of Cycles</u>	<u>Cycles/min.</u>
+ .0 to 0.5	35.0	600	56
+ .0 to 0.6	42.0	70	56
+ .0 to 1.3	91.0	1	

671 cycles completed

**Deflection**      **Set**  
 0.375"              0.00"

**Negative Loads**

**Design Pressure - 70.0 psf.**

<u>Range of Test</u>	<u>Actual Load (psf.)</u>	<u># of Cycles</u>	<u>Cycles/min.</u>
+ .0 to 0.5	35.0	600	56
+ .0 to 0.6	42.0	70	56
+ .0 to 1.3	91.0	1	

671 cycles completed

**Deflection**      **Set**  
 0.250"              0.00"

**Result:** Specimen showed no resultant failure or duress after cycle test. No failure of fasteners. There were no cracks longer than 5" x 1/16" through which air could pass observed.

The results obtained and reported apply only to the specimens tested.

**Comment:** Nominal 2 mil polyethylene film was used to seal against air leakage during structural loads. The film was used in a manner that did not influence the test results.

**Drawings to be Submitted:**

Submittal drawings numbered, 2037W sheets 1 thru 3 of 3, and marked with the CTL stamp are a part of this report.

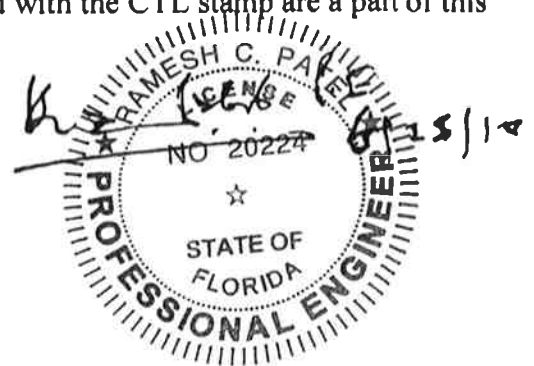

**Remarks:** Detailed drawings were available for laboratory records and comparison to the test specimen at the time of this report. A copy of this report along with representative sections of the test specimen will be retained by CTL for a period of ten (10) years. The results obtained apply only to the specimen tested.

This test report does not constitute certification of this product, but only that the above test results were obtained using the designated test methods and they indicate compliance with the performance requirements (paragraphs as listed) of the above referenced specifications.

Certified Testing Laboratories assumes that all information provided by the client is accurate and that the physical and chemical properties of the components are as stated by the manufacturer.

Observers

Yuriy Farber - Ingersoll-Rand  
Kevin Schmidt - Ingersoll-Rand  
Snehil Solanki - Ingersoll-Rand

Dade County Witness:

Not present

All Tests Witnessed by:

Ramesh Patel P.E.  
Stephen Gibbs      - CTL



Jonathan Pittenger  
Lab Technician  
Architectural Division  
Certified Testing Laboratories



cc:    Ingersoll-Rand      (4)  
      Ramesh Patel      (1)  
      File                (1)



CTLA No. **20371w-3**

Date Verified: **1/28/10**  
 Verified By: **[Signature]**

R E V I S I O N S		
LTR	DESCRIPTION	DATE
A	APPROVAL DWG	06/28/10
		APPROVED

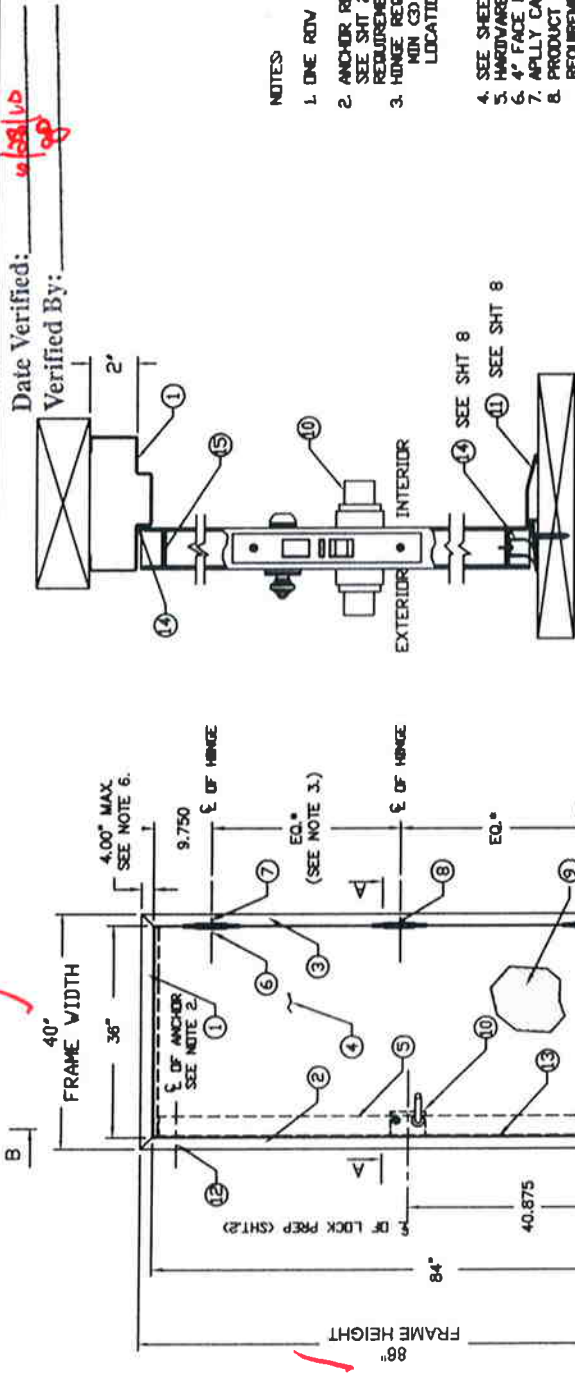

**NOTES**

- ONE RDV OF PS074 WEATHERSTRIPPING PER JAMB AND HEAD.
- ANCHOR REQUIREMENTS SEE SHT 2 FOR TESTED ANCHOR AND INSTALLATION REQUIREMENTS.
- HINGE REQUIREMENTS: MIN CD HINGES: LOCATIONS: 9.75" FROM RABBIT IN HEAD TO CL OF TOP HINGE 10.38" FROM FLOOR TO CL OF BOTTOM HINGE, EQUALLY SPACED IN BETWEEN.
- SEE SHEET 6 FOR AVAILABLE STANDARD OPENING SIZES AND SPECIFICATIONS.
- HARDWARE INSTALLATION AS PER MANUFACTURER'S INSTRUCTIONS.
- 4" FACE HEAD IS AVAILABLE WHEN FRAME IS GROUTED WITH CONCRETE.
- APPLY CALK AS NEEDED.
- PRODUCT IS NOT APPROVED WHERE WATER INFILTRATION REQUIREMENT IS NEEDED.

SECTION B-B SHOWN WITH MORTISE LOCK

ITEM	QUANTITY	DESCRIPTION	MATERIAL	SIZE
1	1	HEAD SEE SHT 2, ASTM A366 STRIKE JAMB SEE SHT 2	.053" MIN. STL	MAX. 40"
2	1	HINGE JAMB SEE SHT 2, ASTM A366 DOOR SLAB	.053" MIN. STL	MAX. 88"
3	1	LOCK SLAB	SEE SHT 8	MAX. 88"
4	1	LOCK SIZE REINFORCEMENT	.070" (14 GA. STL)	3.0" X 7.0" MAX.
5	NOTE 3	HINGE REINFORCEMENT DOOR	8 GA. MIN. STL	1.25" X 8"
6	NOTE 3	HINGE REINFORCEMENT FRAME	.171" (7 GA.) MIN. STL	1.25" X 5.19"
8	NOTE 3	4.5" X 4.5" BUTT HINGES	.134 MIN.	(4) #12-24 MS PER HINGE
9	1	CORE MATERIAL: POLYSTYRENE		35.66" X 81.5" MAX.
10	1	LOCKING HARDWARE - LOCKS BY FALCON BY FALCON HARDWARE LOCKS BY FALCON 2.1 SERIES OR B SERIES CYLINDRICAL LOCK		
11	1	THRESHOLD SILL W/BUMPER GASKET, SHT.2 NATL. GUARD 950A	.100" ALUM. 6063 T5	5.5" X 0.5" X .36" MAX
12	NOTE 2	JAMB ANCHOR	SEE SHT. 5	
13	3	PS074 WEATHER STRIPPING, SHEET 2	ITE	MAX. 21"
14	1	FAS-SEAL DOOR SWEEP, SHEET 2	ITE	MAX. 35.66"
15	2	END CHANNEL ASTM A924	.070" MIN. STL	.69" X 1.66" X 35.66" MAX.
16	AS NEEDED	BUTYL RUBBER OR LOCK SILICONE		

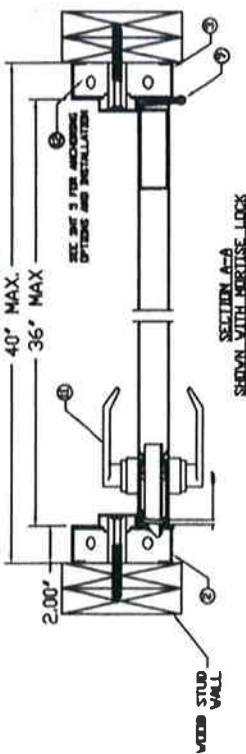
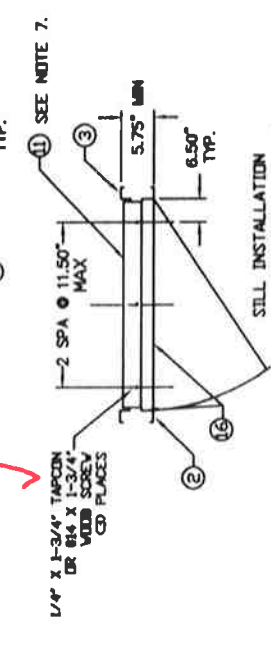

**Ingersoll Rand**  
 Security Technologies

TITLE: HWZ TEST FOR S2 SERIES SINGLE FLUSH DOOR BY STEELORF WITH LOCKS BY FALCON WITH LOCKS BY FALCON

DATE: 06/28/10

SIZE: 11" X 17"

SCALE: NTS

PROJECT: 2037W

SHEET 1 OF 3

REVISIONS

LTR	DESCRIPTION	DATE	APPROVED
A	TEST DWGS.	06/28/10	

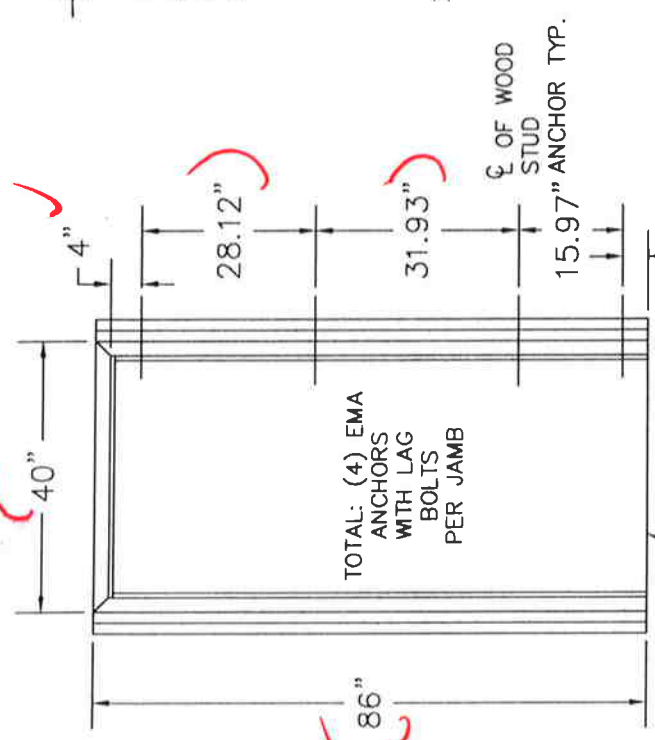

TOTAL: (4) EMA ANCHORS WITH LAG BOLTS PER JAMB

REFER TO SILL INSTALLATION DETAIL (SHT.1)

EXISTING MASONRY ANCHOR (EMA) WITH LAG BOLT INTO WOOD STUD WALL

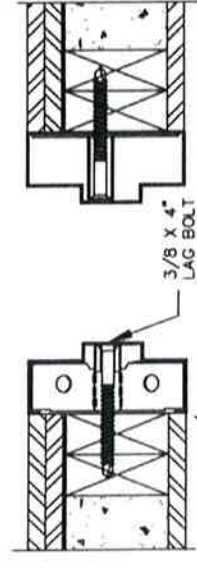

SHIM SPACE 1/4" MAX.

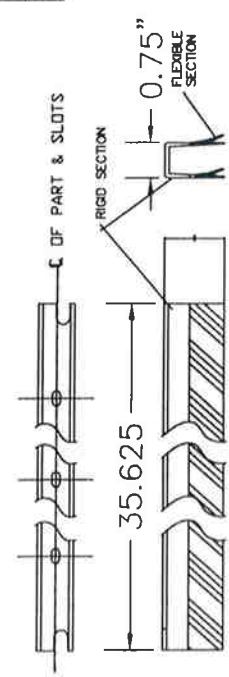

FAS-SEAL DOOR SWEEP

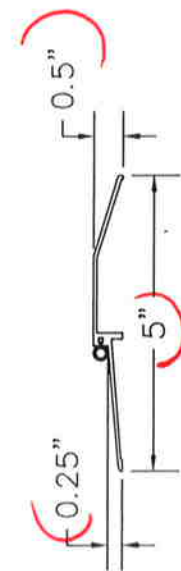

NATIONAL GUARD 950 SERIES THRESHOLD WITH SILICONE, VINYL OR NEOPRENE BUMPER

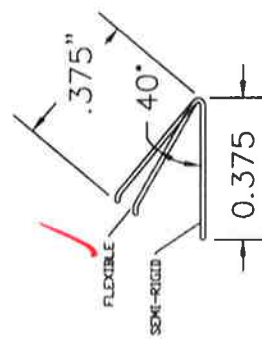

PS-07A SELF-ADHESIVE WEATHERSTRIPPING

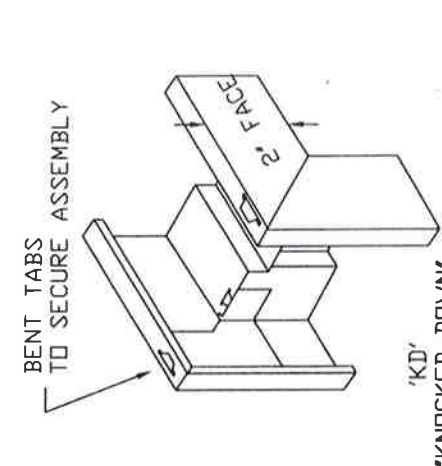

'KD' 'KNOCKED-DOWN' ASSEMBLY

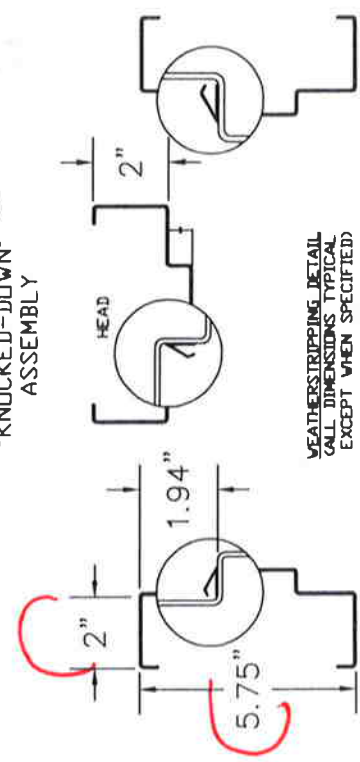

HINGE JAMB

STRIKE JAMB

WEATHERSTRIPPING DETAIL CALL DIMENSIONS TYPICAL EXCEPT WHEN SPECIFIED

		TITLE: DADE COUNTY ANCHOR DETAILS / MOUNTING CONDITIONS	
BEND RADIUS 	DATE: 06/28/10	SCALE: NTS	AUTOCAD: 2037W
TYPED AND CHECKED: YMF	APPROVED:	SIZE: FLAT	REV: A
DATE: 06/28/10	ENG. NO.: 2037W	SHEET: 2 OF 3	REV: A

**CTLA**  
 ARCHITECTURAL DIVISION  
 7252 NARCOOSSEE ROAD  
 ORLANDO, FLORIDA 32822

CTLA No. 2037W-2  
 Date Verified: 6/28/10  
 Verified By: [Signature]



ARCHITECTURAL DIVISION  
7252 NARCOOSSEE ROAD  
ORLANDO, FLORIDA 32822

CTLA No. 203710-2  
Date Verified: 6/28/10  
Verified By: gg

R E V I S I O N S		
LTR	DESCRIPTION	DATE
A	TEST DVG	06/28/10

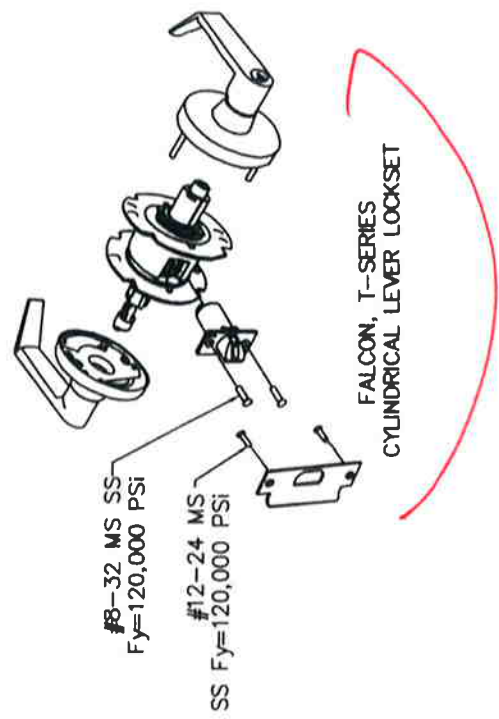
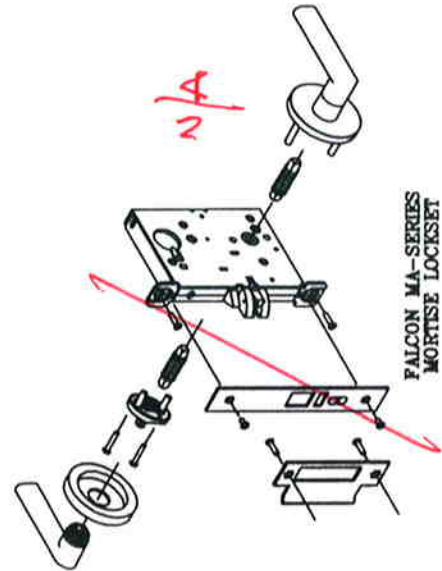
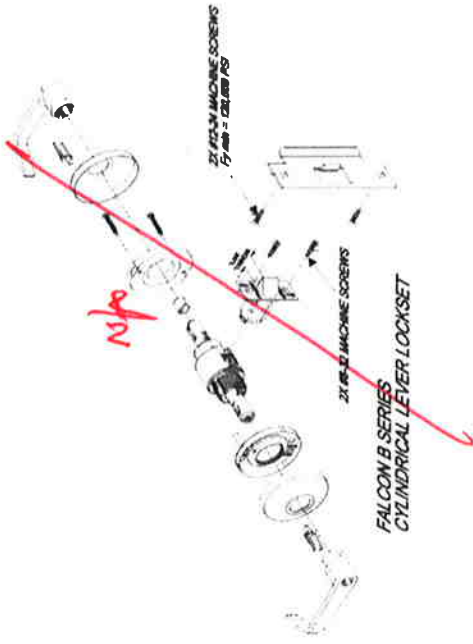

		<b>Ingersoll Rand</b> Security Technologies	
TITLE HVAZ TEST FOR SZ SERIES SINGLE FLUSH DOOR BY STEELCRAFT WITH LOCKS BY FALCON: T, B AND MA-SERIES	DATE 06/28/10	DRAWN YMF	ENG. NO. 2037W
CHECKED	APPROVED	SCALE NTS	SHEET 3 OF 3

DESIGN PRESSURE RATING			
MAX. DOOR SIZE	MIN. LATCH THROW	OUTSWING	INSWING
3070	9/16"	+80/-60 PSF	+60/-80 PSF

LARGE AND SMALL MISSILE RESISTANT PER TAS 201 & 203

R E V I S I O N S			
LTR	DESCRIPTION	DATE	APPROVED
A	NEW	YMF 6/29/10	

**CTLA**  
 CERTIFIED TESTING LABORATORIES  
 ARCHITECTURAL DIVISION  
 7252 NARCOOSSEE ROAD  
 ORLANDO, FLORIDA 32822

CTLA No. 2037W-2  
 Date Verified: 012810  
 Verified By: \_\_\_\_\_

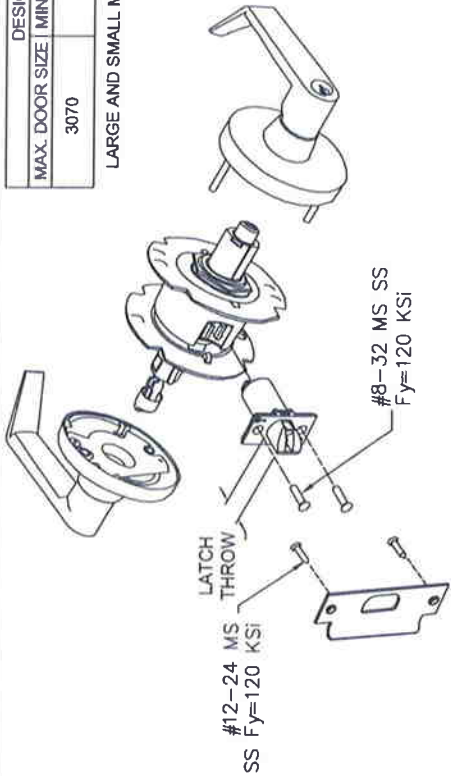

CYLINDRICAL LOCKSET FALCON T-SERIES

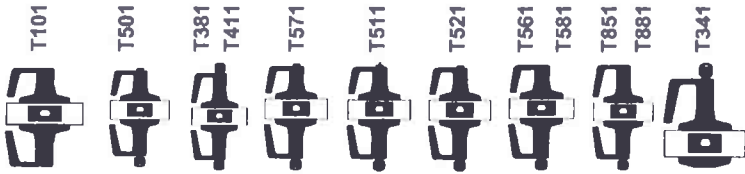

AVAILABLE LEVER DESIGNS

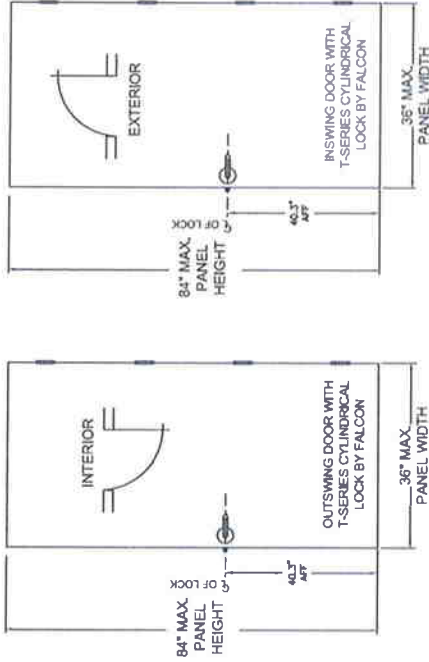

NOTES:

1. ALL FINISHES OFFERED.
2. SEE CHART FOR AVAILABLE FUNCTIONAL OPTIONS.
3. ELECTRICAL INSTALLATION IS UNDER SEPARATE APPROVAL AND MUST BE REVIEWED BY CORRESPONDING AUTHORITY.
4. THIS LOCKSET IS APPROVED TO BE EQUAL ALTERNATIVE TO BE USED IN SINGLE 18 GA STEEL COMMERCIAL DOORS HOLDING CURRENT APPROVAL WITH MID PANEL HARDWARE LATCHING.
5. THE LOWEST DESIGN PRESSURE RATING SHALL APPLY.
6. THE DEVICE SHOULD BE INSTALLED IN COMMERCIAL STEEL DOOR NO WIDER THAN 36" AND NO HIGHER THAN 84".
7. OPTIONAL SIGNAL SWITCH AND POWER TRANSFER UNITS MAY BE USED AS ALLOWED BY CODE AND IF DOESNT AFFECT THE MECHANICAL PROPERTIES OF THIS EXIT DEVICE AND/OR INHIBIT EGRESS.
8. THIS HARDWARE CAN BE INSTALLED AS PART OF IMPACT RESISTANT UNIT.

	THIRD ANGLE PROJECTION
YMF	DATE
DECDED	APPROVED
	ENG. APPROV.



TITLE  
 FLORIDA BUILDING CODE  
 PRODUCT APPROVAL  
 T-SERIES BY FALCON  
 CYLINDRICAL LOCK

SIZE	SCALE
FLAT	NTS
IRFBCT	AUTOCAD

SHEET	REV
1 OF 1	A