

Evaluation Report

of

Millennium Metals, Inc.

“M-Seam”

Metal Roof Assembly

for

Florida Product Approval

FL 4866.1 R1

Florida Building Code 2007

Per Rule 9B-72

Method: 1 - D

Category: Roofing

Sub - Category: Metal Roofing

Product: M-Seam Roof Panel

Material: Steel

Panel Thickness: 26 Gauge Minimum

Panel Dimensions: 16” Net Coverage Width

Support Type: 1/2” Plywood Deck

Prepared for:

Millennium Metals, Inc.

10200 Eastport Road

Jacksonville, FL 32218

Prepared by:

James L. Buckner, P.E.

Florida Professional Engineer # 31242

Florida Evaluation ANE ID: 1916

Project Manager: Diana Galloway

Report No. 08-135-MSeam-16-S6W-1/2”-ER

Date: 3 / 19 / 08

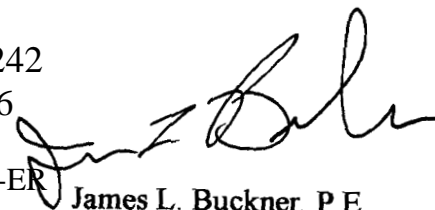

James L. Buckner, P.E.

Florida P.E. # 31242

3/26/08

Contents:

Evaluation Report Pages 1 – 7

CBUCK, Inc.

1334 S. Killian Drive, Suite 4, West Palm Beach, Florida 33403

Phone: (561)491-9927 Fax: (561)491-9928 Website: www.cbuckinc.net

CBUCK Engineering

Specialty Structural Engineering

CBUCK, Inc. Florida Certificate of Authorization # 8064

Manufacturer:	Millennium Metals, Inc.
Product Name:	M-Seam
Product Category:	Roofing
Product Sub-Category	Metal Roofing
Compliance Method:	State Product Approval Rule 9B-72.070 (1) (d)
Panel Description:	M-Seam, Nailstrip, Standing Seam, Steel Roof Panel
Panel Material / Standards:	Material Type: Steel Yield Strength: 40 ksi minimum Corrosion Resistance: Material shall comply with the Florida Building Code (FBC), 2007 Table 1507.4.3.
Panel Dimension(s)	Width: 16" Maximum (Net Coverage Width) Thickness: 26 gauge minimum Rib Height: 1"
Support Type:	Wood Deck (Design of support system is not included in this evaluation)
Support Description:	<ul style="list-style-type: none">• 15/32" or greater plywood, or• Wood plank
Slope Range:	Minimum slope shall be per FBC 2007, Section 1507.4.2, and in compliance with the Manufacturers recommendations But no less than: 2 : 12.
Design Uplift Pressure:	<ul style="list-style-type: none">• Method 1: -84.25 PSF (Safety Factor of 2 : 1)• Method 2: -91.75 PSF (Safety Factor of 2 : 1)
Underlayment:	Underlayment shall be per manufacturer's guidelines as required in FBC Section 1507.4.5
Insulation:	(Optional) Rigid Insulation Board, 3" maximum thickness and with a density of 2.25 pcf (lbs/ft ³) minimum or a compressive strength of 25 psi minimum.
Fire Classification:	Fire Classification is outside the scope of Rule 9B-72, and is therefore not included in this evaluation. Additional approved substrates may be added for Fire Classification purposes.

CBUCK Engineering

Specialty Structural Engineering

CBUCK, Inc. Florida Certificate of Authorization # 8064

Component(s) Description: **Roof Panel Fasteners**
Type: Pancake-Head wood screws
Size: #10 x minimum penetration through deck 3/16"
Corrosion Resistance: Per FBC Section 1507.4.4
Standard: Per ANSI/ASME B18.6.1.

Installation:

METHOD 1:

1. **"M-Seam" Roof Panel to Deck**
 - Row spacing: 8" o.c.
(along the length of the panel and within 3" from all ends)
 - Panel ribs shall be fully engaged to form an integral snap-lock

METHOD 2:

2. **"M-Seam" Roof Panel to Deck**
 - Row spacing: 4" o.c.
(along the length of the panel and within 3" from all ends)
 - Panel ribs shall be fully engaged to form an integral snap-lock

Fasteners shall penetrate through deck a minimum of 3/16".

Install the system in compliance with the attached installation method.
Refer to manufacturer's installation instructions as a supplemental guide for attachment.

Quality Assurance: The manufacturer has demonstrated compliance of roof panel products in accordance with the Florida Building Code and Rule 9B-72.070 (3) for manufacturing under a quality assurance program audited by an approved quality assurance entity through **Keystone Certifications, Inc.** (FBC Organization #: QUA 1824)

Performance Standards: The product described herein has been tested in accordance with:

- **UL580-94 – Test for Uplift Resistance of Roof Assemblies—with Revisions through February 1998**
- **UL 1897-98 – Uplift test for roof covering systems**

Code Compliance: The product described herein has demonstrated compliance with the Florida Building Code 2007, Section 1504.3.2

Evaluation Report Scope: This product evaluation is limited to compliance with the structural wind load requirements of the Florida Building Code, as related to Rule 9B-72.

CBUCK Engineering

Specialty Structural Engineering

CBUCK, Inc. Florida Certificate of Authorization # 8064

System Limitations:

The required design wind loads shall be determined for each project per FBC, 2007, Section 1603.1.4. Any rational analysis shall be prepared by a qualified design professional and in compliance with FBC 2007, Sections 104, 105, 106. The maximum fastener spacing listed herein shall not be exceeded. This product is not approved for use in the High Velocity Hurricane Zone.

Referenced Data:

1. UL580-94 & UL 1897-98 Uplift Test
By Hurricane Test Laboratory, LLC (FBC Organization #TST ID: 1527)
Report #: 0232-0508-05, Report Date: 6/29/05
Specimens #1-3
2. Quality Assurance
By Keystone Certifications, Inc., (FBC Organization #QUA ID:1824)
Millennium Metals Licensee # 423
3. Certification of Independence
By James L. Buckner, P.E. @ C-Buck Engineering
(FBC Organization # ANE 1916)
4. Engineering Calculations
By C-Buck Engineering
 - Report #C08-135, Dated: 3/20/08

CBUCK Engineering

Specialty Structural Engineering

CBUCK, Inc. Florida Certificate of Authorization # 8064

Installation Method Millennium Metals, Inc. "M-Seam" (26 Ga. Steel) Roof Panel Attached to 1/2" Wood Deck

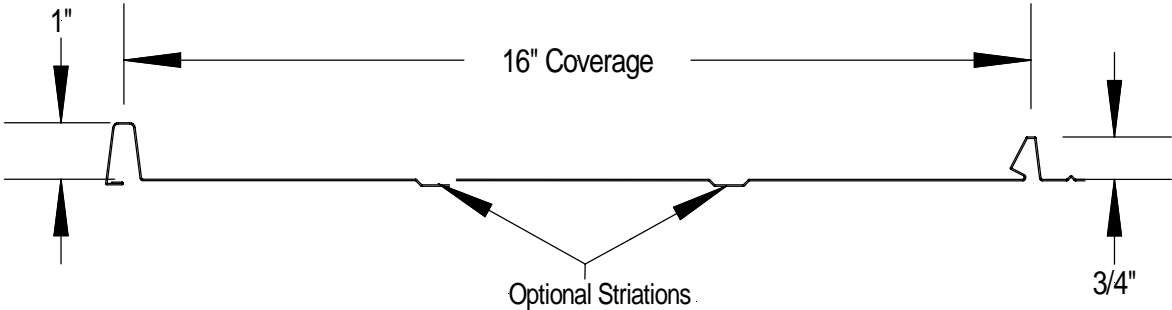

"M-Seam" Typical Panel Profile View

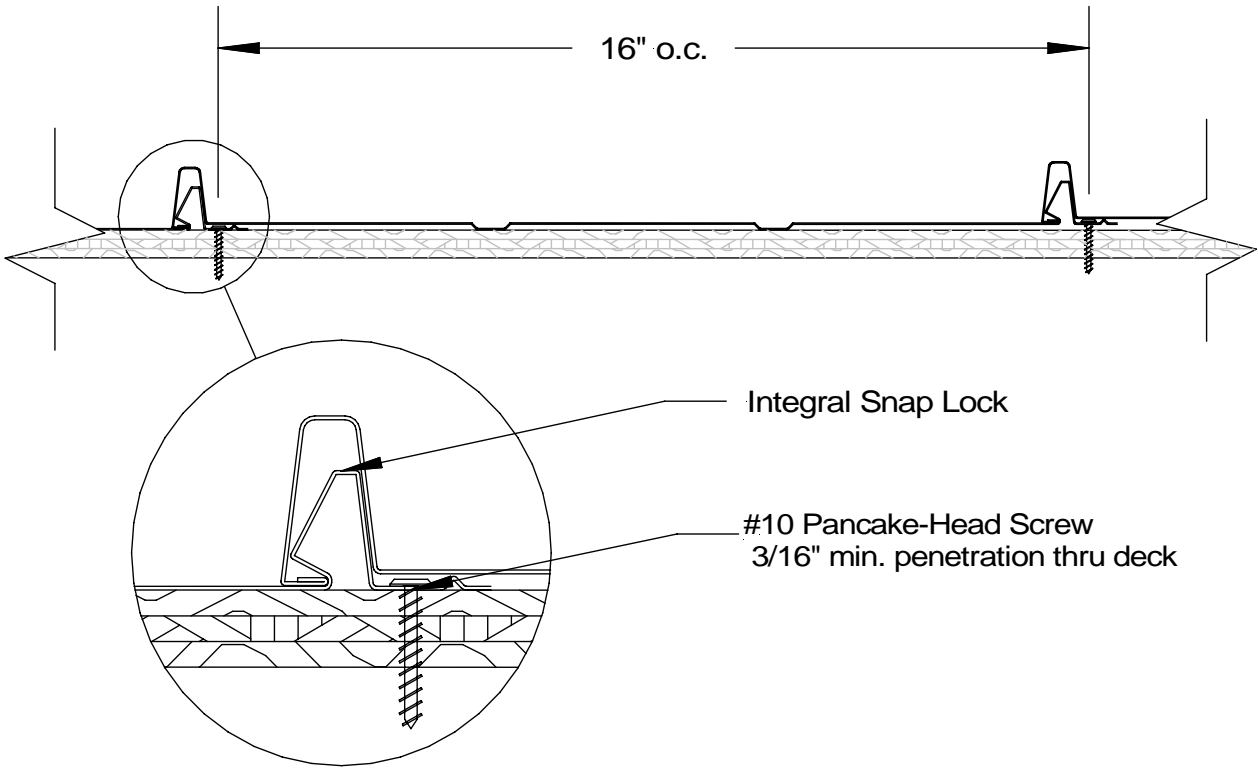

Typical Assembly Profile View

CBUCK Engineering

Specialty Structural Engineering

CBUCK, Inc. Florida Certificate of Authorization # 8064

Installation Method Millennium Metals, Inc. "M-Seam" (26 Ga. Steel) Roof Panel Attached to 1/2" Wood Deck

Method 1 (For -84.25 PSF Design Pressure)

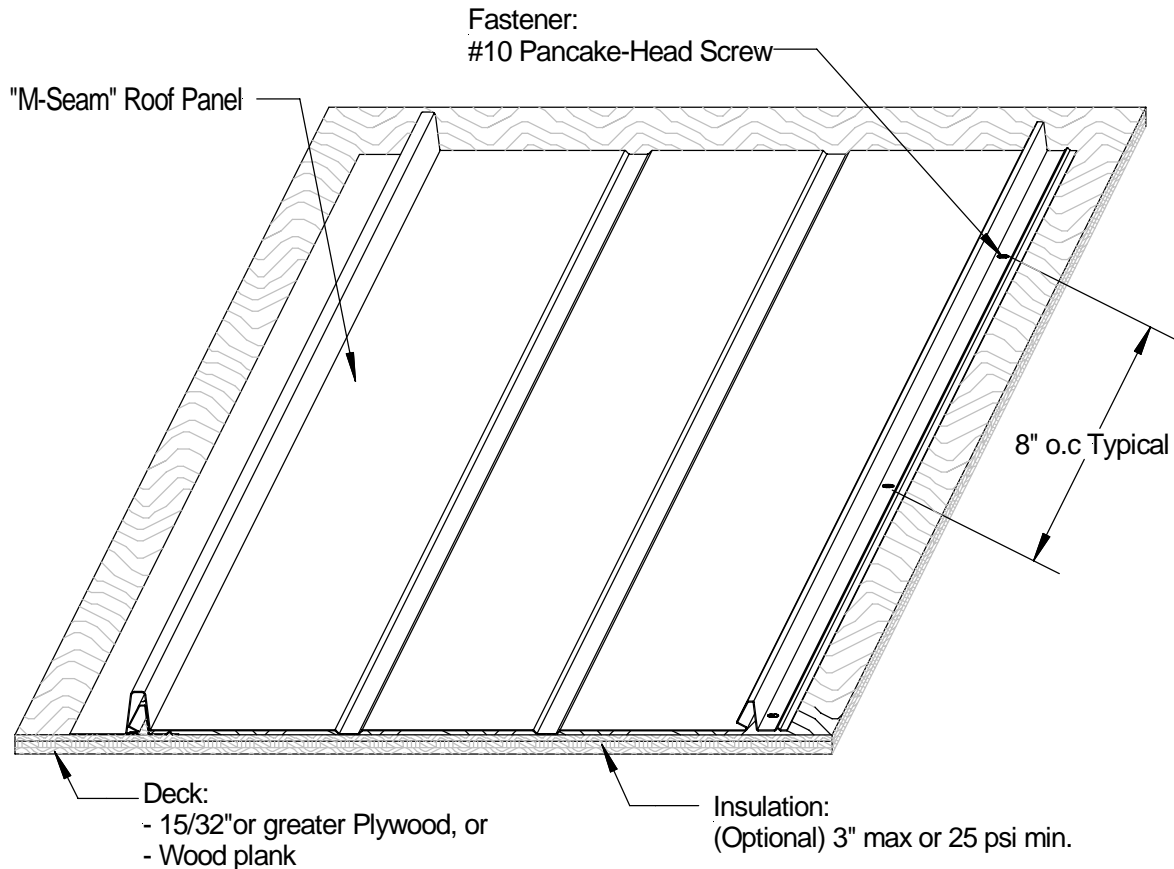

Typical Assembly Isometric View

CBUCK Engineering

Specialty Structural Engineering

CBUCK, Inc. Florida Certificate of Authorization # 8064

Installation Method Millennium Metals, Inc. "M-Seam" (26 Ga. Steel) Roof Panel Attached to 1/2" Wood Deck

Method 2 (For -91.75 PSF Design Pressure)

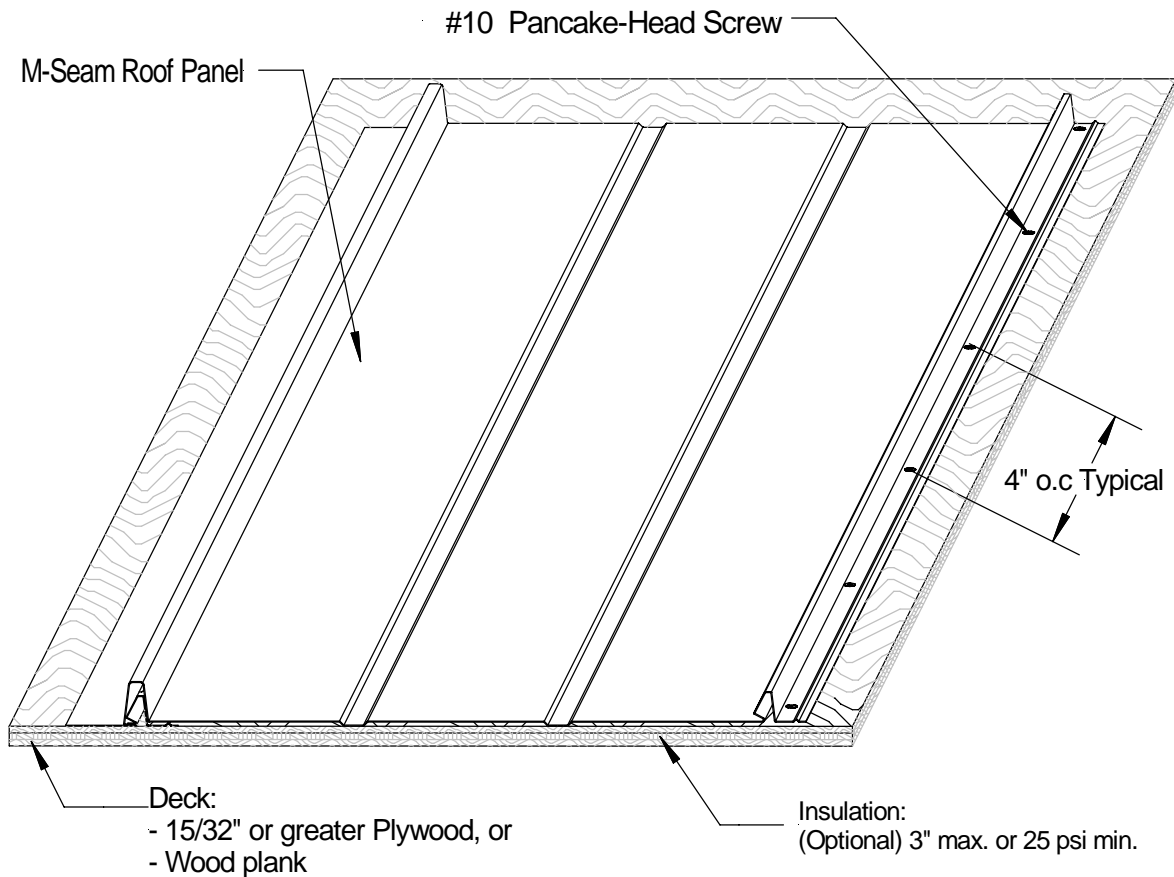

Typical Assembly Isometric View