

Code Review

2018 Changes to International Codes

IRC - BUILDING - STRUCTURAL - STRUCTURAL TAC

W A R N I N G

Copyright Notice: This document has been reproduced solely for considering proposed changes to the Florida Building Code with the permission of the International Code Council, Inc., is the copyrighted property of the International Code Council, Inc., all rights reserved, and may not be further reproduced or distributed.

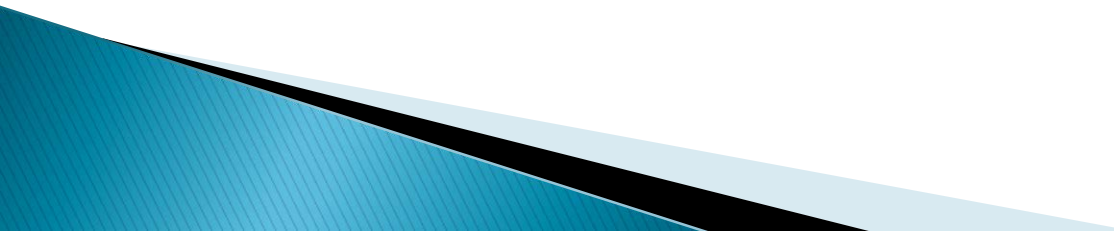
W A R N I N G



Residential Code (IRC) - (Structural)

RCCIWG and

Structural Technical Advisory Committee (TAC)



2018 International Residential Code – Building/Structural TAC

IRC-Building Code Change No.	IRC-Building Section	Change Summary b/t 2015 IRC-B and 2018 IRC-B	Change Summary b/t 2017 IRC-B and 2018 IRC-B	Staff comments
RB2-16	R202, M1305.1, M1407.4, M1503.4, M1601.1.2, M1601.4.1, M1803.3.5, M1803.4.3, M2204.2, M2301.2.1, R1001.2.1, R1003.9.2, R202, R202 (New), R301.5, R302.7, R308.4.3, R308.4.6, R308.6.2, R308.6.5, R310.5, R311.3, R807.1	<p>Deletes definitions “ACCESSIBLE”, “ACCESSIBLE”. Adds definitions “READILY”, “ACCESS (TO)”, “READY ACESS (TO)”. Modifies Definitions “CLEANOUT”, “FIXTURE FITTING”. Modifies text of Table R301.5 “MINIMUM UNIFORMLY DISTRIBUTED LIVE LOADS”.</p> <p>Modifies text of Section R302.7 “Under-stair protection”, R308.4.3 “Glazing in windows”, R308.4.6 “Glazing adjacent to stairs and ramps”, R308.6.2 “Materials.” R308.6.5 “Screens not required”, R310.5 “Dwelling additions”, R311.3 “Floors and landings at exterior doors”, R807.1 “Attic access”, R1001.2.1 “Ash dump cleanout”, R1003.9.2 “Spark arrestors”, M1305.1 “Appliance access for inspection service, repair and replacement”, M1407.4 “Access”, M1503.4 “Makeup air required”, M1601.1.2 “Underground duct systems”, M1601.4.1 “Joints, seams and connections”, M1803.3.5 “Access,” M1803.4.3 “Connection to masonry fireplace flue,” M2204.2 “Shutoff valves”, M2301.2.1 “Access”.</p> <p>The intent of this proposal is for clarification of terminology. This proposal will clarify where the provisions are for access for repair, not accessibility for persons with disabilities. This clarifies the code by separating something that is accessible from something that is accessed.</p> <p>Cost Impact: Will not increase the cost of construction. This is a clarification of terminology that will have no change on code requirements.</p>	Same as change between 2015 IRC-B and 2018 IRC-B	

Rule 61G20-2.002 2. Technical amendments needed to accommodate the specific needs of this state include but are not limited to amendments to the Florida Building Code that provide for the following: a. Establish minimum life safety construction requirements to protect buildings and their occupants from fire, wind, flood, and storm surge using the latest technical research and engineering standards for buildings and materials products. b. Provide for flood protection provisions that are consistent with the latest flood protection requirements of the National Flood Insurance Program. c. Maintain eligibility for federal funding and discounts from the National Flood Insurance Program, the Federal Emergency Management Agency, and the United States Department of Housing and Urban Development. d. Provide for energy efficiency standards for buildings that meet or exceed the national energy standards as mandated by Title III of the Energy Conservation and Protection Act. e. Maintain coordination with the Florida Fire Prevention Code. f. Provide for the latest industry standards and design

RCCIWG – Comment		TAC Action	Commission Action		TAC	Commission
Impactful (Explain) <input type="checkbox"/>		Accommodate Florida Specific Need: YES (Select Criteria) <input type="checkbox"/> NO: <input type="checkbox"/> a. <input type="checkbox"/> b. <input type="checkbox"/> c. <input type="checkbox"/> d. <input type="checkbox"/> e. <input type="checkbox"/> f. <input type="checkbox"/> Others (Explain):	Accommodate Florida Specific Need: YES (Select Criteria) <input type="checkbox"/> NO: <input type="checkbox"/> a. <input type="checkbox"/> b. <input type="checkbox"/> c. <input type="checkbox"/> d. <input type="checkbox"/> e. <input type="checkbox"/> f. <input type="checkbox"/> Others (Explain):	<input type="checkbox"/> No Action Needed	<input type="checkbox"/>	<input type="checkbox"/>
				<input type="checkbox"/> Overlapping provisions	<input type="checkbox"/>	<input type="checkbox"/>
RB6-16	R202	Adds definition “CRAWL SPACE.” to Section R202. Per reasoning necessary to create a definition that is appropriate and to distinguish those spaces from "basement". Cost Impact: Will not increase the cost of construction. This is an editorial revision that will have no impact on construction costs.	Same as change between 2015 IRC-B and 2018 IRC-B			
Impactful (Explain) <input type="checkbox"/>		Accommodate Florida Specific Need: YES (Select Criteria) <input type="checkbox"/> NO: <input type="checkbox"/> a. <input type="checkbox"/> b. <input type="checkbox"/> c. <input type="checkbox"/> d. <input type="checkbox"/> e. <input type="checkbox"/> f. <input type="checkbox"/> Others (Explain):	Accommodate Florida Specific Need: YES (Select Criteria) <input type="checkbox"/> NO: <input type="checkbox"/> a. <input type="checkbox"/> b. <input type="checkbox"/> c. <input type="checkbox"/> d. <input type="checkbox"/> e. <input type="checkbox"/> f. <input type="checkbox"/> Others (Explain):	<input type="checkbox"/> No Action Needed	<input type="checkbox"/>	<input type="checkbox"/>
				<input type="checkbox"/> Overlapping provisions	<input type="checkbox"/>	<input type="checkbox"/>
RB17-16	R301.2, R301.2(3) (New), R301.2(3)-continued (New), R301.2.2.1.1, R301.2.2.1.2	Modifies text of Section R301.2.2.1.1 “Alternate determination of seismic design category”, R301.2.2.1.2 “Alternative determination of Seismic Design Category E”. Adds new Figure R301.2(3). Deletes FIGURE R301.2(2) “SEISMIC DESIGN CATEGORIES”. This proposal incorporates the most current seismic design maps prepared by the U.S. Geological Survey (USGS) in collaboration with the Federal Emergency Management Agency (FEMA) and the Building Seismic Safety Council (BSSC). A separate coordinated code change updates the seismic design maps in the IBC to be consistent with these IRC maps and the maps incorporated into ASCE 7-16. Cost Impact: Will increase the cost of construction. This code change can result in modest increases OR decreases in construction cost depending on geographic region. Where the	Same as change between 2015 IRC-B and 2018 IRC-B (Seismic provisions do not apply to buildings in Florida)	No action needed.		

Rule 61G20-2.002 2. Technical amendments needed to accommodate the specific needs of this state include but are not limited to amendments to the Florida Building Code that provide for the following: a. Establish minimum life safety construction requirements to protect buildings and their occupants from fire, wind, flood, and storm surge using the latest technical research and engineering standards for buildings and materials products. b. Provide for flood protection provisions that are consistent with the latest flood protection requirements of the National Flood Insurance Program. c. Maintain eligibility for federal funding and discounts from the National Flood Insurance Program, the Federal Emergency Management Agency, and the United States Department of Housing and Urban Development. d. Provide for energy efficiency standards for buildings that meet or exceed the national energy standards as mandated by Title III of the Energy Conservation and Protection Act. e. Maintain coordination with the Florida Fire Prevention Code. f. Provide for the latest industry standards and design

		<p>R301.2(2) Seismic Design Category maps are used, limited locations as illustrated by the attached USGS maps, will increase or decrease in Seismic Design Category, increasing or decreasing seismic bracing requirements and cost a modest amount. The amount of increase will vary depending on the specific change in Seismic Design Category, the wind bracing requirements, and the particulars of the dwelling and its construction. In some cases increases in Seismic Design Category and resulting cost can be reduced if not eliminated where the site soils allow the use of the Alternate Seismic Design Category maps. NIST GCR 14-917-26, Cost Analyses and Benefits for Earthquake-Resistant Construction in Memphis, Tennessee, provides one example of the magnitude of seismic design cost impact; the increment in cost for apartment building construction between design for code required wind loads and national seismic design provisions is on the order of one percent of construction cost.</p>												
<p>RCCIWG – Comment</p> <p>Impactful (Explain) <input type="checkbox"/></p>	<p>TAC Action</p> <p>Accommodate Florida Specific Need: YES (Select Criteria) <input type="checkbox"/> NO: <input type="checkbox"/></p> <p>a. <input type="checkbox"/> b. <input type="checkbox"/> c. <input type="checkbox"/> d. <input type="checkbox"/> e. <input type="checkbox"/> f. <input type="checkbox"/></p> <p>Others (Explain):</p>	<p>Commission Action</p> <p>Accommodate Florida Specific Need: YES (Select Criteria) <input type="checkbox"/> NO: <input type="checkbox"/></p> <p>a. <input type="checkbox"/> b. <input type="checkbox"/> c. <input type="checkbox"/> d. <input type="checkbox"/> e. <input type="checkbox"/> f. <input type="checkbox"/></p> <p>Others (Explain):</p>	<p><input type="checkbox"/> No Action Needed</p> <p><input type="checkbox"/> Overlapping provisions</p>	<table border="1"> <thead> <tr> <th></th> <th>TAC</th> <th>Commission</th> </tr> </thead> <tbody> <tr> <td><input type="checkbox"/> No Action Needed</td> <td><input type="checkbox"/></td> <td><input type="checkbox"/></td> </tr> <tr> <td><input type="checkbox"/> Overlapping provisions</td> <td><input type="checkbox"/></td> <td><input type="checkbox"/></td> </tr> </tbody> </table>		TAC	Commission	<input type="checkbox"/> No Action Needed	<input type="checkbox"/>	<input type="checkbox"/>	<input type="checkbox"/> Overlapping provisions	<input type="checkbox"/>	<input type="checkbox"/>	
	TAC	Commission												
<input type="checkbox"/> No Action Needed	<input type="checkbox"/>	<input type="checkbox"/>												
<input type="checkbox"/> Overlapping provisions	<input type="checkbox"/>	<input type="checkbox"/>												
<p>RB23-16</p>	<p>R301.2.2, R301.2.2.4</p>	<p>Modifies text of Section R301.2.2 “Seismic provisions” and modifies R301.2.2.4 “Seismic Design Category E”. The purpose of this code change is to clarify the application of the IRC for seismic design.</p> <p>Cost Impact: Will not increase the cost of construction. The code change provides editorial clarifications to the application of the code in high-seismic areas. No seismic requirements are added or removed with this change, thus there should be no impact on cost.</p>	<p>Same as change between 2015 IRC-B and 2018 IRC-B (Seismic provisions do not apply to buildings in Florida)</p>	<p>No action needed</p>										

Rule 61G20-2.002 2. Technical amendments needed to accommodate the specific needs of this state include but are not limited to amendments to the Florida Building Code that provide for the following: a. Establish minimum life safety construction requirements to protect buildings and their occupants from fire, wind, flood, and storm surge using the latest technical research and engineering standards for buildings and materials products. b. Provide for flood protection provisions that are consistent with the latest flood protection requirements of the National Flood Insurance Program. c. Maintain eligibility for federal funding and discounts from the National Flood Insurance Program, the Federal Emergency Management Agency, and the United States Department of Housing and Urban Development. d. Provide for energy efficiency standards for buildings that meet or exceed the national energy standards as mandated by Title III of the Energy Conservation and Protection Act. e. Maintain coordination with the Florida Fire Prevention Code. f. Provide for the latest industry standards and design

RCCIWG – Comment		TAC Action	Commission Action		TAC	Commission
Impactful (Explain) <input type="checkbox"/>		Accommodate Florida Specific Need: YES (Select Criteria) <input type="checkbox"/> NO: <input type="checkbox"/> a. <input type="checkbox"/> b. <input type="checkbox"/> c. <input type="checkbox"/> d. <input type="checkbox"/> e. <input type="checkbox"/> f. <input type="checkbox"/> Others (Explain): <input type="text"/>	Accommodate Florida Specific Need: YES (Select Criteria) <input type="checkbox"/> NO: <input type="checkbox"/> a. <input type="checkbox"/> b. <input type="checkbox"/> c. <input type="checkbox"/> d. <input type="checkbox"/> e. <input type="checkbox"/> f. <input type="checkbox"/> Others (Explain): <input type="text"/>	<input type="checkbox"/> No Action Needed	<input type="checkbox"/>	<input type="checkbox"/>
				<input type="checkbox"/> Overlapping provisions	<input type="checkbox"/>	<input type="checkbox"/>
RB24-16	R301.2.2, R301.2.2.2, R301.2.2.2.1, R301.2.2.2.2, R301.2.2.2.3, R301.2.2.2.4, R301.2.2.2.5, R301.2.2.3, R301.2.2.3.1, R301.2.2.3.2, R301.2.2.3.3, R301.2.2.3.4, R301.2.2.3.5, R301.2.2.3.6, R301.2.2.3.7, R301.2.2.4, R301.2.2.6.1 (New), R301.2.2.6.2 (New), R301.2.2.6.3 (New), R301.2.2.6.4 (New), R301.2.2.6.5 (New), R301.2.2.6.6 (New), R301.2.2.6.7 (New)	<p>Modifies text of Section R301.2.2 “Seismic provisions”, R301.2.2.2 “Weights of materials”, R301.2.2.3 “Stone and masonry veneer”, R301.2.2.4 “Masonry construction”, R301.2.2.5 “Concrete construction”, R301.2.2.6 “Irregular buildings”, R301.2.2.7 “Height limitations”, R301.2.2.8 “Cold-formed steel framing in Seismic Design Categories D0, D1 and D2”. Revises text of Section R301.2.2.9 “Masonry chimneys”, R301.2.2.10 “Anchorage of water heaters”, R301.2.2.11 “Seismic Design Category E”. Deleted Section R301.2.2.3.3 Masonry construction R301.2.2.2 Seismic Design Category C. R301.2.2.4 Concrete construction. R301.2.2.3 Seismic Design Categories D0, D1 and D2. R301.2.2.3.2 Stone and masonry veneer, R302.3.3.7 “Height Limitations”.</p> <p>The purpose of this code change is to reorganize the seismic provisions of Chapter 3. Builders in regions of the country where seismic design is required have expressed confusion regarding the requirements and limitations of Section R301.2.2</p> <p>Cost Impact: Will not increase the cost of construction. The code change provides an editorial clarification and reorganization to the irregularity and material requirements and limitations in high-seismic areas. No seismic requirements are added or removed with this change, thus there should be no impact on cost.</p>	Same as change between 2015 IRC-B and 2018 IRC-B (Seismic provisions do not apply to buildings in Florida)	No action needed		

Rule 61G20-2.002 2. Technical amendments needed to accommodate the specific needs of this state include but are not limited to amendments to the Florida Building Code that provide for the following: a. Establish minimum life safety construction requirements to protect buildings and their occupants from fire, wind, flood, and storm surge using the latest technical research and engineering standards for buildings and materials products. b. Provide for flood protection provisions that are consistent with the latest flood protection requirements of the National Flood Insurance Program. c. Maintain eligibility for federal funding and discounts from the National Flood Insurance Program, the Federal Emergency Management Agency, and the United States Department of Housing and Urban Development. d. Provide for energy efficiency standards for buildings that meet or exceed the national energy standards as mandated by Title III of the Energy Conservation and Protection Act. e. Maintain coordination with the Florida Fire Prevention Code. f. Provide for the latest industry standards and design

RCCIWG – Comment		TAC Action	Commission Action		TAC	Commission
Impactful (Explain) <input type="checkbox"/>		Accommodate Florida Specific Need: YES (Select Criteria) <input type="checkbox"/> NO: <input type="checkbox"/> a. <input type="checkbox"/> b. <input type="checkbox"/> c. <input type="checkbox"/> d. <input type="checkbox"/> e. <input type="checkbox"/> f. <input type="checkbox"/> Others (Explain): 	Accommodate Florida Specific Need: YES (Select Criteria) <input type="checkbox"/> NO: <input type="checkbox"/> a. <input type="checkbox"/> b. <input type="checkbox"/> c. <input type="checkbox"/> d. <input type="checkbox"/> e. <input type="checkbox"/> f. <input type="checkbox"/> Others (Explain): 	<input type="checkbox"/> No Action Needed	<input type="checkbox"/>	<input type="checkbox"/>
				<input type="checkbox"/> Overlapping provisions	<input type="checkbox"/>	<input type="checkbox"/>
RB160-16	R322.3.3, R322.3.4	<p>Modifies text of Section R322.3.3 “Foundations”. Adds new section R322.3.4 “Concrete slabs”. Coastal high hazard areas (Zone V) and Coastal A Zones are portions of flood hazard areas along open shorelines where wave action will occur. The presence of concrete slabs can increase damage to elevated buildings, in part by shifting such that added loads or increased scour occurs on the building foundation. This proposal helps clarify what is intended by the requirement in R322.3.3. The code change was further modified by public comment. The public comment provides for a performance statement which would require assessment as to whether damage would result if slabs were displaced and two options. The first is prescriptive – slabs built as specified will break up when undermined by scour and erosion thus site-specific consideration of scour is not required. The second retains the requirement to consider erosion and local scour (removing the word "expected"), which is necessary for slabs to actually function as self-supporting slabs. Final</p> <p>Cost Impact: Will not increase the cost of construction. The free of obstruction requirement has been enforced by communities that participate in the National Flood Insurance Program and FEMA guidance has long advised the requirement can be satisfied by requiring concrete slabs to meet the proposed specifications.</p>	Same as change between 2015 IRC-B and 2018 IRC-B		Flood provisions	

Rule 61G20-2.002 2. Technical amendments needed to accommodate the specific needs of this state include but are not limited to amendments to the Florida Building Code that provide for the following: a. Establish minimum life safety construction requirements to protect buildings and their occupants from fire, wind, flood, and storm surge using the latest technical research and engineering standards for buildings and materials products. b. Provide for flood protection provisions that are consistent with the latest flood protection requirements of the National Flood Insurance Program. c. Maintain eligibility for federal funding and discounts from the National Flood Insurance Program, the Federal Emergency Management Agency, and the United States Department of Housing and Urban Development. d. Provide for energy efficiency standards for buildings that meet or exceed the national energy standards as mandated by Title III of the Energy Conservation and Protection Act. e. Maintain coordination with the Florida Fire Prevention Code. f. Provide for the latest industry standards and design

RCCIWG – Comment		TAC Action	Commission Action		TAC	Commission
Impactful (Explain) <input type="checkbox"/>		Accommodate Florida Specific Need: YES (Select Criteria) <input type="checkbox"/> NO: <input type="checkbox"/> a. <input type="checkbox"/> b. <input type="checkbox"/> c. <input type="checkbox"/> d. <input type="checkbox"/> e. <input type="checkbox"/> f. <input type="checkbox"/> Others (Explain): <input type="text"/>	Accommodate Florida Specific Need: YES (Select Criteria) <input type="checkbox"/> NO: <input type="checkbox"/> a. <input type="checkbox"/> b. <input type="checkbox"/> c. <input type="checkbox"/> d. <input type="checkbox"/> e. <input type="checkbox"/> f. <input type="checkbox"/> Others (Explain): <input type="text"/>	<input type="checkbox"/> No Action Needed	<input type="checkbox"/>	<input type="checkbox"/>
				<input type="checkbox"/> Overlapping provisions	<input type="checkbox"/>	<input type="checkbox"/>
RB161-16	R322.3.6 (New)	<p>Adds new Section R322.3.6 “Stairways and ramps”. Coastal high hazard areas (Zone V) and Coastal A Zones are portions of flood hazard areas along open shorelines where wave action will occur. Stairways and ramp for dwellings are affected by flooding, erosion and scour and the presence of stairways and ramps can increase damage to elevated buildings. This proposal helps clarify what is intended by the requirement in R322.3.3 that the area below elevated buildings shall be free of obstructions. The code change was further modified by the Committee as follows: In the modification, Section R322.3.6 Item 1 went from language that is wide open and vague to something that is concrete, which is very helpful in the code. The proposal adds needed clarity.</p> <p>Per comment “The purpose of this public comment is to revise and expand the guidance on stairways and ramps added by this proposal.”</p> <p>Cost Impact: Will not increase the cost of construction. The requirement to avoid obstructions and to have elements below elevated buildings breakaway has been enforced by communities that participate in the NFIP, whether by enforcement of the IRC or local floodplain management regulations. FEMA guidance has long advised the requirement can be satisfied by requiring stairways and ramps to meet the proposed specifications.</p>	Same as change between 2015 IRC-B and 2018 IRC-B	Flood provision		

Rule 61G20-2.002 2. Technical amendments needed to accommodate the specific needs of this state include but are not limited to amendments to the Florida Building Code that provide for the following: a. Establish minimum life safety construction requirements to protect buildings and their occupants from fire, wind, flood, and storm surge using the latest technical research and engineering standards for buildings and materials products. b. Provide for flood protection provisions that are consistent with the latest flood protection requirements of the National Flood Insurance Program. c. Maintain eligibility for federal funding and discounts from the National Flood Insurance Program, the Federal Emergency Management Agency, and the United States Department of Housing and Urban Development. d. Provide for energy efficiency standards for buildings that meet or exceed the national energy standards as mandated by Title III of the Energy Conservation and Protection Act. e. Maintain coordination with the Florida Fire Prevention Code. f. Provide for the latest industry standards and design

RCCIWG – Comment		TAC Action	Commission Action		TAC	Commission
Impactful (Explain) <input type="checkbox"/>		Accommodate Florida Specific Need: YES (Select Criteria) <input type="checkbox"/> NO: <input type="checkbox"/> a. <input type="checkbox"/> b. <input type="checkbox"/> c. <input type="checkbox"/> d. <input type="checkbox"/> e. <input type="checkbox"/> f. <input type="checkbox"/> Others (Explain): <input type="text"/>	Accommodate Florida Specific Need: YES (Select Criteria) <input type="checkbox"/> NO: <input type="checkbox"/> a. <input type="checkbox"/> b. <input type="checkbox"/> c. <input type="checkbox"/> d. <input type="checkbox"/> e. <input type="checkbox"/> f. <input type="checkbox"/> Others (Explain): <input type="text"/>	<input type="checkbox"/> No Action Needed <input type="checkbox"/> Overlapping provisions	<input type="checkbox"/>	<input type="checkbox"/>
RB162-16	R322.3.6 (New)	Adds text of Section R322.3.6 “Decks and porches”. Coastal high hazard areas (Zone V) and Coastal A Zones are portions of flood hazard areas along open shorelines where wave action will occur. Decks and porches attached to or adjacent to dwellings are affected by flooding, erosion and scour. The presence of decks and porches can increase damage to elevated buildings unless they are constructed in ways intended to minimize damage. This proposal clarifies how decks and porches are treated and is based on the requirements of referenced standard ASCE 24-14, Flood Resistant Design and Construction and best practices documented in several publications issued by the Federal Emergency Management Agency Cost Impact: Will not increase the cost of construction. The elevation requirement and free of obstruction requirement have been enforced by communities that participate in the National Flood Insurance Program and FEMA guidance has long advised the requirement can be satisfied by requiring decks and porches to meet the proposed specifications.		Same as change between 2015 IRC-B and 2018 IRC-B	Flood provision	
Impactful (Explain) <input type="checkbox"/>		Accommodate Florida Specific Need: YES (Select Criteria) <input type="checkbox"/> NO: <input type="checkbox"/> a. <input type="checkbox"/> b. <input type="checkbox"/> c. <input type="checkbox"/> d. <input type="checkbox"/> e. <input type="checkbox"/> f. <input type="checkbox"/> Others (Explain): <input type="text"/>	Accommodate Florida Specific Need: YES (Select Criteria) <input type="checkbox"/> NO: <input type="checkbox"/> a. <input type="checkbox"/> b. <input type="checkbox"/> c. <input type="checkbox"/> d. <input type="checkbox"/> e. <input type="checkbox"/> f. <input type="checkbox"/> Others (Explain): <input type="text"/>	<input type="checkbox"/> No Action Needed <input type="checkbox"/> Overlapping provisions	<input type="checkbox"/>	<input type="checkbox"/>

Rule 61G20-2.002 2. Technical amendments needed to accommodate the specific needs of this state include but are not limited to amendments to the Florida Building Code that provide for the following: a. Establish minimum life safety construction requirements to protect buildings and their occupants from fire, wind, flood, and storm surge using the latest technical research and engineering standards for buildings and materials products. b. Provide for flood protection provisions that are consistent with the latest flood protection requirements of the National Flood Insurance Program. c. Maintain eligibility for federal funding and discounts from the National Flood Insurance Program, the Federal Emergency Management Agency, and the United States Department of Housing and Urban Development. d. Provide for energy efficiency standards for buildings that meet or exceed the national energy standards as mandated by Title III of the Energy Conservation and Protection Act. e. Maintain coordination with the Florida Fire Prevention Code. f. Provide for the latest industry standards and design

<p>RB164-16</p>	<p>R324.3, R324.3.1, R324.4, R324.4.1, R324.5, R324.5.1, R324.5.2 (New), R907, R907.1, R907.2, R907.3, R907.4, R907.5, R909, R909.1, R909.2, R909.3</p>	<p>Modifies Sections R324.3 “Photovoltaic systems”, R324.3.1 “Equipment listings”, R324.4 “Rooftop-mounted photovoltaic systems”, R324.4.1 “Structural requirements”, R324.4.1.1 “Roof live load”, R324.4.1.2 “Wind resistance”, R324.4.2 “Fire classification”, R324.4.3 “Roof penetrations”, R324.5 “Building-integrated photovoltaic systems”, R324.5.1 “Photovoltaic shingles”, Section R907 “ROOFTOP-MOUNTED PHOTOVOLTAIC PANEL SYSTEMS”. Adds new Section R324.5.2 “Fire classification”.</p> <p>Deletes Section R907.4 “Installation”, R907.5 “Photovoltaic panels and modules”, SECTION R909 “ROOFTOP-MOUNTED PHOTOVOLTAIC PANEL SYSTEMS”.</p> <p>Proposal RM98-13 established R324, which was intended to consolidate and organize all the requirements, with necessary section revisions and section additions, in an easily-used format that assists the user to find all the applicable requirements – fire, electrical, structural, plumbing, and mechanical – related to solar thermal and photovoltaic systems. The intent of this proposal is to address redundant code requirements and consolidate/reorganize requirements that were also included in Chapter 9 during the last code cycle. These changes will help to address any confusion regarding the installation of photovoltaic systems.</p> <p>Cost Impact: Will not increase the cost of construction. The proposal clarifies the applicable requirements for photovoltaic systems.</p>	<p>Same as change between 2015 IRC-B and 2018 IRC-B</p>		
<p>RCCIWG – Comment</p> <p>Impactful (Explain) <input type="checkbox"/></p>	<p>TAC Action</p> <p>Accommodate Florida Specific Need: YES (Select Criteria) <input type="checkbox"/> NO: <input type="checkbox"/> a. <input type="checkbox"/> b. <input type="checkbox"/> c. <input type="checkbox"/> d. <input type="checkbox"/> e. <input type="checkbox"/> f. <input type="checkbox"/> Others (Explain):</p>	<p>Commission Action</p> <p>Accommodate Florida Specific Need: YES (Select Criteria) <input type="checkbox"/> NO: <input type="checkbox"/> a. <input type="checkbox"/> b. <input type="checkbox"/> c. <input type="checkbox"/> d. <input type="checkbox"/> e. <input type="checkbox"/> f. <input type="checkbox"/> Others (Explain):</p>	<p><input type="checkbox"/> No Action Needed</p> <p><input type="checkbox"/> Overlapping provisions</p>	<p>TAC</p> <p><input type="checkbox"/></p> <p><input type="checkbox"/></p>	<p>Commission</p> <p><input type="checkbox"/></p> <p><input type="checkbox"/></p>

Rule 61G20-2.002 2. Technical amendments needed to accommodate the specific needs of this state include but are not limited to amendments to the Florida Building Code that provide for the following:

a. Establish minimum life safety construction requirements to protect buildings and their occupants from fire, wind, flood, and storm surge using the latest technical research and engineering standards for buildings and materials products. b. Provide for flood protection provisions that are consistent with the latest flood protection requirements of the National Flood Insurance Program. c. Maintain eligibility for federal funding and discounts from the National Flood Insurance Program, the Federal Emergency Management Agency, and the United States Department of Housing and Urban Development. d. Provide for energy efficiency standards for buildings that meet or exceed the national energy standards as mandated by Title III of the Energy Conservation and Protection Act. e. Maintain coordination with the Florida Fire Prevention Code. f. Provide for the latest industry standards and design

RB165-16	R324.4.1	<p>Revises text of section R324.4.1 “Roof live load”. This proposal is intended to clarify and correct the requirements for design loads for roofs with PV panels. The current code text is confusing, incomplete, and technically incorrect.</p> <p>Cost Impact: Will not increase the cost of construction. This proposal merely clarifies how loads are to be applied to the roof structure. Properly-designed roof structures should have been using the load cases in this proposal, so no change in cost or construction is anticipated.</p>	Same as change between 2015 IRC-B and 2018 IRC-B		
<p>RCCIWG – Comment</p> <p>Impactful (Explain) <input type="checkbox"/></p>	<p>TAC Action</p> <p>Accommodate Florida Specific Need:</p> <p>YES (Select Criteria) <input type="checkbox"/> NO: <input type="checkbox"/></p> <p>a. <input type="checkbox"/> b. <input type="checkbox"/> c. <input type="checkbox"/> d. <input type="checkbox"/> e. <input type="checkbox"/> f. <input type="checkbox"/></p> <p>Others (Explain):</p>	<p>Commission Action</p> <p>Accommodate Florida Specific Need:</p> <p>YES (Select Criteria) <input type="checkbox"/> NO: <input type="checkbox"/></p> <p>a. <input type="checkbox"/> b. <input type="checkbox"/> c. <input type="checkbox"/> d. <input type="checkbox"/> e. <input type="checkbox"/> f. <input type="checkbox"/></p> <p>Others (Explain):</p>	<p><input type="checkbox"/> No Action Needed</p> <p><input type="checkbox"/> Overlapping provisions</p>	<p>TAC</p> <p><input type="checkbox"/></p> <p><input type="checkbox"/></p>	<p>Commission</p> <p><input type="checkbox"/></p> <p><input type="checkbox"/></p>
RB172-16	R202 (New), R401.4, R801.3R202 (New), R401.4, R801.3	<p>Adds definitions “COLLAPSIBLE SOILS”, “COMPRESSIBLE SOILS”, “EXPANSIVE SOILS”. Modifies text of Section R401.4 “Soil tests”, R801.3 “Roof drainage”. There is currently no definition for collapsible soils to provide guidance to design professionals and building officials on identification and design procedures to address these soils. These terms are used in IRC Section R401.4 and R801.3.</p> <p>Cost Impact: Will not increase the cost of construction. The change is for clarification so there is not change to construction requirements.</p>	Same as change between 2015 IRC-B and 2018 IRC-B		
<p>RCCIWG – Comment</p> <p>Impactful (Explain) <input type="checkbox"/></p>	<p>TAC Action</p> <p>Accommodate Florida Specific Need:</p> <p>YES (Select Criteria) <input type="checkbox"/> NO: <input type="checkbox"/></p> <p>a. <input type="checkbox"/> b. <input type="checkbox"/> c. <input type="checkbox"/> d. <input type="checkbox"/> e. <input type="checkbox"/> f. <input type="checkbox"/></p> <p>Others (Explain):</p>	<p>Commission Action</p> <p>Accommodate Florida Specific Need:</p> <p>YES (Select Criteria) <input type="checkbox"/> NO: <input type="checkbox"/></p> <p>a. <input type="checkbox"/> b. <input type="checkbox"/> c. <input type="checkbox"/> d. <input type="checkbox"/> e. <input type="checkbox"/> f. <input type="checkbox"/></p> <p>Others (Explain):</p>	<p><input type="checkbox"/> No Action Needed</p> <p><input type="checkbox"/> Overlapping provisions</p>	<p>TAC</p> <p><input type="checkbox"/></p> <p><input type="checkbox"/></p>	<p>Commission</p> <p><input type="checkbox"/></p> <p><input type="checkbox"/></p>

Rule 61G20-2.002 2. Technical amendments needed to accommodate the specific needs of this state include but are not limited to amendments to the Florida Building Code that provide for the following:

a. Establish minimum life safety construction requirements to protect buildings and their occupants from fire, wind, flood, and storm surge using the latest technical research and engineering standards for buildings and materials products. b. Provide for flood protection provisions that are consistent with the latest flood protection requirements of the National Flood Insurance Program. c. Maintain eligibility for federal funding and discounts from the National Flood Insurance Program, the Federal Emergency Management Agency, and the United States Department of Housing and Urban Development. d. Provide for energy efficiency standards for buildings that meet or exceed the national energy standards as mandated by Title III of the Energy Conservation and Protection Act. e. Maintain coordination with the Florida Fire Prevention Code. f. Provide for the latest industry standards and design

RB173-16	R401.2	<p>Modifies text of Section R401.2 “Requirements”. The recommendation is to eliminate the last sentence from Section R401.2 for clarification concerning gravel fill.</p> <p>Cost Impact: Will not increase the cost of construction. This proposal will not increase the cost of construction because it merely seeks to provide clarification and eliminates superfluous language without changing the technical requirements of the code.</p>	This change is not similar to that of the FRC. The FRC provides for Florida specific changes to this section	Overlapping provision to be considered during step 2 of the code change process
----------	--------	--	--	---

RCCIWG – Comment	TAC Action	Commission Action		TAC	Commission
Impactful (Explain) <input type="checkbox"/>	Accommodate Florida Specific Need: YES (Select Criteria) <input type="checkbox"/> NO: <input type="checkbox"/> a. <input type="checkbox"/> b. <input type="checkbox"/> c. <input type="checkbox"/> d. <input type="checkbox"/> e. <input type="checkbox"/> f. <input type="checkbox"/> Others (Explain): <input type="text"/>	Accommodate Florida Specific Need: YES (Select Criteria) <input type="checkbox"/> NO: <input type="checkbox"/> a. <input type="checkbox"/> b. <input type="checkbox"/> c. <input type="checkbox"/> d. <input type="checkbox"/> e. <input type="checkbox"/> f. <input type="checkbox"/> Others (Explain): <input type="text"/>	<input type="checkbox"/> No Action Needed <input type="checkbox"/> Overlapping provisions	<input type="checkbox"/> <input type="checkbox"/>	<input type="checkbox"/> <input type="checkbox"/>

RB176-16	R403.1.1	<p>Modifies text of Section R403.1.1 “Minimum size.” This proposal simply adds one sentence to section R403.1.1 that points the reader to the precast footing section (Section R403.4) for instructions on constructing footings for precast.</p> <p>Cost Impact: Will not increase the cost of construction. This proposal will not increase the cost of construction because it only seeks to provide clarification by restoring a reference to precast footings that was lost in a previous code change. This proposal is not changing the technical requirements of the code.</p>	This change is not similar to that of the FRC. The FRC provides for Florida specific changes to this section	Overlapping provision to be considered during step 2 of the code change process
----------	----------	---	--	---

RCCIWG – Comment	TAC Action	Commission Action		TAC	Commission
Impactful (Explain) <input type="checkbox"/>	Accommodate Florida Specific Need: YES (Select Criteria) <input type="checkbox"/> NO: <input type="checkbox"/> a. <input type="checkbox"/> b. <input type="checkbox"/> c. <input type="checkbox"/> d. <input type="checkbox"/> e. <input type="checkbox"/> f. <input type="checkbox"/> Others (Explain): <input type="text"/>	Accommodate Florida Specific Need: YES (Select Criteria) <input type="checkbox"/> NO: <input type="checkbox"/> a. <input type="checkbox"/> b. <input type="checkbox"/> c. <input type="checkbox"/> d. <input type="checkbox"/> e. <input type="checkbox"/> f. <input type="checkbox"/> Others (Explain): <input type="text"/>	<input type="checkbox"/> No Action Needed <input type="checkbox"/> Overlapping provisions	<input type="checkbox"/> <input type="checkbox"/>	<input type="checkbox"/> <input type="checkbox"/>

Rule 61G20-2.002 2. Technical amendments needed to accommodate the specific needs of this state include but are not limited to amendments to the Florida Building Code that provide for the following:

a. Establish minimum life safety construction requirements to protect buildings and their occupants from fire, wind, flood, and storm surge using the latest technical research and engineering standards for buildings and materials products. b. Provide for flood protection provisions that are consistent with the latest flood protection requirements of the National Flood Insurance Program. c. Maintain eligibility for federal funding and discounts from the National Flood Insurance Program, the Federal Emergency Management Agency, and the United States Department of Housing and Urban Development. d. Provide for energy efficiency standards for buildings that meet or exceed the national energy standards as mandated by Title III of the Energy Conservation and Protection Act. e. Maintain coordination with the Florida Fire Prevention Code. f. Provide for the latest industry standards and design

RB177-16	R403.1.6	<p>Modifies text of Section R403.1.6 “Foundation anchorage”. This proposed revision is an editorial change intended to clarify the anchorage requirements for cold-formed steel wall assemblies.</p> <p>Cost Impact: Will not increase the cost of construction. This is simply a proposed editorial change that does not affect the intended prescribed construction requirements.</p>	Same as change between 2015 IRC-B and 2018 IRC-B			
<p>RCCIWG – Comment</p> <p>Impactful (Explain) <input type="checkbox"/></p>		<p>TAC Action</p> <p>Accommodate Florida Specific Need: YES (Select Criteria) <input type="checkbox"/> NO: <input type="checkbox"/></p> <p>a. <input type="checkbox"/> b. <input type="checkbox"/> c. <input type="checkbox"/> d. <input type="checkbox"/> e. <input type="checkbox"/> f. <input type="checkbox"/></p> <p>Others (Explain):</p>	<p>Commission Action</p> <p>Accommodate Florida Specific Need: YES (Select Criteria) <input type="checkbox"/> NO: <input type="checkbox"/></p> <p>a. <input type="checkbox"/> b. <input type="checkbox"/> c. <input type="checkbox"/> d. <input type="checkbox"/> e. <input type="checkbox"/> f. <input type="checkbox"/></p> <p>Others (Explain):</p>	<p><input type="checkbox"/> No Action Needed</p> <p><input type="checkbox"/> Overlapping provisions</p>	<p>TAC</p> <p><input type="checkbox"/></p> <p><input type="checkbox"/></p>	<p>Commission</p> <p><input type="checkbox"/></p> <p><input type="checkbox"/></p>
RB178-16	R403.4	<p>Modifies table R403.4 “MINIMUM DEPTH AND WIDTH OF CRUSHED STONE FOOTINGS”. This proposal changes this table to include both the depth (D) and width (W) as is already shown in figure R403.4(1). This table (Table R403.4 Minimum Depth of Crushed Stone Footings) only provides the Depth (D) in inches of crushed stone footings for precast, but the Width (W) is also needed to fully describe a crushed stone footing and how it spreads the load of the precast concrete wall into the soil.</p> <p>Cost Impact: Will not increase the cost of construction. This proposal will not increase the cost of construction because the changes to this table do not increase the average amount of crushed stone that is typically used for footings to support precast foundations. It is already standard practice for builders and precast foundation manufacturers to include crushed stone footing widths (W) wider than the maximum widths (W) that are required in the table. Stone depths and widths in the table are minimums and in the field, these depths and widths are usually over estimated to assure minimums are easily met. The width dimension (W) has been added to the table to prevent anyone from overlooking this important minimum dimension of a crushed stone footing. When recalculating all of the depths for the table, some of the crushed stone footing depths (D) also change by 1 inch, some increased and some</p>	Same as change between 2015 IRC-B and 2018 IRC-B			

Rule 61G20-2.002 2. Technical amendments needed to accommodate the specific needs of this state include but are not limited to amendments to the Florida Building Code that provide for the following: a. Establish minimum life safety construction requirements to protect buildings and their occupants from fire, wind, flood, and storm surge using the latest technical research and engineering standards for buildings and materials products. b. Provide for flood protection provisions that are consistent with the latest flood protection requirements of the National Flood Insurance Program. c. Maintain eligibility for federal funding and discounts from the National Flood Insurance Program, the Federal Emergency Management Agency, and the United States Department of Housing and Urban Development. d. Provide for energy efficiency standards for buildings that meet or exceed the national energy standards as mandated by Title III of the Energy Conservation and Protection Act. e. Maintain coordination with the Florida Fire Prevention Code. f. Provide for the latest industry standards and design

		decreased, but the changes are negligible and it will not increase the cost of construction.		
RCCIWG – Comment	TAC Action	Commission Action	TAC	Commission
Impactful (Explain) <input type="checkbox"/>	Accommodate Florida Specific Need: YES (Select Criteria) <input type="checkbox"/> NO: <input type="checkbox"/> a. <input type="checkbox"/> b. <input type="checkbox"/> c. <input type="checkbox"/> d. <input type="checkbox"/> e. <input type="checkbox"/> f. <input type="checkbox"/> Others (Explain):	Accommodate Florida Specific Need: YES (Select Criteria) <input type="checkbox"/> NO: <input type="checkbox"/> a. <input type="checkbox"/> b. <input type="checkbox"/> c. <input type="checkbox"/> d. <input type="checkbox"/> e. <input type="checkbox"/> f. <input type="checkbox"/> Others (Explain):	<input type="checkbox"/> No Action Needed	<input type="checkbox"/>
			<input type="checkbox"/> Overlapping provisions	<input type="checkbox"/>
RB179-16	R403.3	<p>Modifies text of table “MINIMUM FOOTING DEPTH AND INSULATION REQUIREMENTS FOR FROST-PROTECTED FOOTINGS IN HEATED BUILDINGS.” This proposal updates the IRC to be consistent with the latest published design values for insulation materials used on frost-protected shallow foundations (FPSF), per ASCE 32-01 Design and Construction of Frost-Protected Shallow Foundations; and to be consistent with the current requirements in the IBC.</p> <p>Cost Impact: Will increase the cost of construction. Depending on the project's design, this proposal may increase the cost of construction, as the design values for below-grade EPS and XPS are revised by this proposal. For most vertical applications, slightly less EPS or XPS will be needed to achieve the required thermal performance. For most horizontal applications, slightly more EPS or XPS will be needed.</p>	Same as change between 2015 IRC-B and 2018 IRC-B	
RCCIWG – Comment	TAC Action	Commission Action	TAC	Commission
Impactful (Explain) <input type="checkbox"/>	Accommodate Florida Specific Need: YES (Select Criteria) <input type="checkbox"/> NO: <input type="checkbox"/> a. <input type="checkbox"/> b. <input type="checkbox"/> c. <input type="checkbox"/> d. <input type="checkbox"/> e. <input type="checkbox"/> f. <input type="checkbox"/> Others (Explain):	Accommodate Florida Specific Need: YES (Select Criteria) <input type="checkbox"/> NO: <input type="checkbox"/> a. <input type="checkbox"/> b. <input type="checkbox"/> c. <input type="checkbox"/> d. <input type="checkbox"/> e. <input type="checkbox"/> f. <input type="checkbox"/> Others (Explain):	<input type="checkbox"/> No Action Needed	<input type="checkbox"/>
			<input type="checkbox"/> Overlapping provisions	<input type="checkbox"/>
RB181-16	R403.4	Modifies text of FIGURE R403.4 (2) “BASEMENT OR CRAWL SPACE WITH PRECAST FOUNDATION WALL ON SPREAD FOOTING”. This proposal updates the figure to add the dimension T for the footing thickness. The modification reverts the figure to the original with dimension T added. The proposed	Same as change between 2015 IRC-B and 2018 IRC-B	

Rule 61G20-2.002 2. Technical amendments needed to accommodate the specific needs of this state include but are not limited to amendments to the Florida Building Code that provide for the following: a. Establish minimum life safety construction requirements to protect buildings and their occupants from fire, wind, flood, and storm surge using the latest technical research and engineering standards for buildings and materials products. b. Provide for flood protection provisions that are consistent with the latest flood protection requirements of the National Flood Insurance Program. c. Maintain eligibility for federal funding and discounts from the National Flood Insurance Program, the Federal Emergency Management Agency, and the United States Department of Housing and Urban Development. d. Provide for energy efficiency standards for buildings that meet or exceed the national energy standards as mandated by Title III of the Energy Conservation and Protection Act. e. Maintain coordination with the Florida Fire Prevention Code. f. Provide for the latest industry standards and design

		<p>figure was too restrictive. The code change was further modified by the Committee. The modification reverts the figure to the original with dimension T added. The proposed figure was too restrictive.</p> <p>Cost Impact: Will not increase the cost of construction. This proposal will not increase the cost of construction. This proposal is NOT changing the technical requirements of the code, it is just clarifying the code by representing a more realistic sill plate connection for a precast foundation and it is adding the thickness (T) dimension, which is currently missing from the figure 403.4(2). Concrete footing requirements remain the same.</p>											
RCCIWG – Comment Impactful (Explain) <input type="checkbox"/>		TAC Action Accommodate Florida Specific Need: YES (Select Criteria) <input type="checkbox"/> NO: <input type="checkbox"/> a. <input type="checkbox"/> b. <input type="checkbox"/> c. <input type="checkbox"/> d. <input type="checkbox"/> e. <input type="checkbox"/> f. <input type="checkbox"/> Others (Explain): _____	Commission Action Accommodate Florida Specific Need: YES (Select Criteria) <input type="checkbox"/> NO: <input type="checkbox"/> a. <input type="checkbox"/> b. <input type="checkbox"/> c. <input type="checkbox"/> d. <input type="checkbox"/> e. <input type="checkbox"/> f. <input type="checkbox"/> Others (Explain): _____	<table border="1"> <tr> <td></td> <td>TAC</td> <td>Commission</td> </tr> <tr> <td><input type="checkbox"/> No Action Needed</td> <td><input type="checkbox"/></td> <td><input type="checkbox"/></td> </tr> <tr> <td><input type="checkbox"/> Overlapping provisions</td> <td><input type="checkbox"/></td> <td><input type="checkbox"/></td> </tr> </table>		TAC	Commission	<input type="checkbox"/> No Action Needed	<input type="checkbox"/>	<input type="checkbox"/>	<input type="checkbox"/> Overlapping provisions	<input type="checkbox"/>	<input type="checkbox"/>
	TAC	Commission											
<input type="checkbox"/> No Action Needed	<input type="checkbox"/>	<input type="checkbox"/>											
<input type="checkbox"/> Overlapping provisions	<input type="checkbox"/>	<input type="checkbox"/>											
RB184-16	R405.1	<p>Modifies text of Section R405.1 Concrete or masonry foundations. Per reasoning "area to be protected" is unclear and should be specified in the code. Placing drain tile too high is a primary cause of leaking basements.</p> <p>Cost Impact: Will not increase the cost of construction. There is no cost increase. Material & labor should be the same.</p>	Same as change between 2015 IRC-B and 2018 IRC-B										
RCCIWG – Comment Impactful (Explain) <input type="checkbox"/>		TAC Action Accommodate Florida Specific Need: YES (Select Criteria) <input type="checkbox"/> NO: <input type="checkbox"/> a. <input type="checkbox"/> b. <input type="checkbox"/> c. <input type="checkbox"/> d. <input type="checkbox"/> e. <input type="checkbox"/> f. <input type="checkbox"/> Others (Explain): _____	Commission Action Accommodate Florida Specific Need: YES (Select Criteria) <input type="checkbox"/> NO: <input type="checkbox"/> a. <input type="checkbox"/> b. <input type="checkbox"/> c. <input type="checkbox"/> d. <input type="checkbox"/> e. <input type="checkbox"/> f. <input type="checkbox"/> Others (Explain): _____	<table border="1"> <tr> <td></td> <td>TAC</td> <td>Commission</td> </tr> <tr> <td><input type="checkbox"/> No Action Needed</td> <td><input type="checkbox"/></td> <td><input type="checkbox"/></td> </tr> <tr> <td><input type="checkbox"/> Overlapping provisions</td> <td><input type="checkbox"/></td> <td><input type="checkbox"/></td> </tr> </table>		TAC	Commission	<input type="checkbox"/> No Action Needed	<input type="checkbox"/>	<input type="checkbox"/>	<input type="checkbox"/> Overlapping provisions	<input type="checkbox"/>	<input type="checkbox"/>
	TAC	Commission											
<input type="checkbox"/> No Action Needed	<input type="checkbox"/>	<input type="checkbox"/>											
<input type="checkbox"/> Overlapping provisions	<input type="checkbox"/>	<input type="checkbox"/>											
RB187-16	R408.3	<p>Modifies text of Section R408.3 "Unvented crawl space". This code change allows another means of conditioning and controlling moisture, specifically dehumidification.</p>	Same as change between 2015 IRC-B and 2018 IRC-B										

Rule 61G20-2.002 2. Technical amendments needed to accommodate the specific needs of this state include but are not limited to amendments to the Florida Building Code that provide for the following: a. Establish minimum life safety construction requirements to protect buildings and their occupants from fire, wind, flood, and storm surge using the latest technical research and engineering standards for buildings and materials products. b. Provide for flood protection provisions that are consistent with the latest flood protection requirements of the National Flood Insurance Program. c. Maintain eligibility for federal funding and discounts from the National Flood Insurance Program, the Federal Emergency Management Agency, and the United States Department of Housing and Urban Development. d. Provide for energy efficiency standards for buildings that meet or exceed the national energy standards as mandated by Title III of the Energy Conservation and Protection Act. e. Maintain coordination with the Florida Fire Prevention Code. f. Provide for the latest industry standards and design

		<p>Cost Impact: Will not increase the cost of construction. This is a no cost change. This is an option. It allows another approach to conditioning crawl spaces that is equal to or less cost compared to providing supply and return air or an exhaust ventilation approach.</p>											
<p>RCCIWG – Comment</p> <p>Impactful (Explain) <input type="checkbox"/></p>	<p>TAC Action</p> <p>Accommodate Florida Specific Need: YES (Select Criteria) <input type="checkbox"/> NO: <input type="checkbox"/> a. <input type="checkbox"/> b. <input type="checkbox"/> c. <input type="checkbox"/> d. <input type="checkbox"/> e. <input type="checkbox"/> f. <input type="checkbox"/> Others (Explain): <input type="text"/></p>	<p>Commission Action</p> <p>Accommodate Florida Specific Need: YES (Select Criteria) <input type="checkbox"/> NO: <input type="checkbox"/> a. <input type="checkbox"/> b. <input type="checkbox"/> c. <input type="checkbox"/> d. <input type="checkbox"/> e. <input type="checkbox"/> f. <input type="checkbox"/> Others (Explain): <input type="text"/></p>	<p><input type="checkbox"/> No Action Needed</p> <p><input type="checkbox"/> Overlapping provisions</p>	<table border="1"> <thead> <tr> <th></th> <th>TAC</th> <th>Commission</th> </tr> </thead> <tbody> <tr> <td><input type="checkbox"/> No Action Needed</td> <td><input type="checkbox"/></td> <td><input type="checkbox"/></td> </tr> <tr> <td><input type="checkbox"/> Overlapping provisions</td> <td><input type="checkbox"/></td> <td><input type="checkbox"/></td> </tr> </tbody> </table>		TAC	Commission	<input type="checkbox"/> No Action Needed	<input type="checkbox"/>	<input type="checkbox"/>	<input type="checkbox"/> Overlapping provisions	<input type="checkbox"/>	<input type="checkbox"/>
	TAC	Commission											
<input type="checkbox"/> No Action Needed	<input type="checkbox"/>	<input type="checkbox"/>											
<input type="checkbox"/> Overlapping provisions	<input type="checkbox"/>	<input type="checkbox"/>											
<p>RB189-16</p>	<p>R502.1.3, R602.1.3, R802.1.2</p>	<p>Modifies text of Section R502.1.3 “Structural glued laminated timbers”, R602.1.3 “Structural glued-laminated timbers”, R802.1.2 “Structural glued laminated timbers”. Adds new standards “ANSI 117-2015 Standard Specifications for Structural Glued Laminated Timber of Softwood Species” ANSI/AITC A190.1 and AITC 117 were renamed as ANSI A190.1 and ANSI 117 with the approval by ANSI. The new name for ANSI A190.1 found its way into Chapter 44 during the 2015 code cycle, but this change corrects references in code chapters.</p> <p>Cost Impact: Will not increase the cost of construction. This code change will not increase the cost of construction. It simply changes the entity responsible for the maintenance of these standards from the now defunct AITC to APA-The Engineered Wood Association.</p>	<p>Same as change between 2015 IRC-B and 2018 IRC-B</p>	<p>No action needed</p> <p>As per R301.2.1.1 of the 2017 FRC, these sections are part of those prescriptive provisions that are not applicable to Florida.</p>									
<p>RCCIWG – Comment</p> <p>Impactful (Explain) <input type="checkbox"/></p>	<p>TAC Action</p> <p>Accommodate Florida Specific Need: YES (Select Criteria) <input type="checkbox"/> NO: <input type="checkbox"/> a. <input type="checkbox"/> b. <input type="checkbox"/> c. <input type="checkbox"/> d. <input type="checkbox"/> e. <input type="checkbox"/> f. <input type="checkbox"/> Others (Explain): <input type="text"/></p>	<p>Commission Action</p> <p>Accommodate Florida Specific Need: YES (Select Criteria) <input type="checkbox"/> NO: <input type="checkbox"/> a. <input type="checkbox"/> b. <input type="checkbox"/> c. <input type="checkbox"/> d. <input type="checkbox"/> e. <input type="checkbox"/> f. <input type="checkbox"/> Others (Explain): <input type="text"/></p>	<p><input type="checkbox"/> No Action Needed</p> <p><input type="checkbox"/> Overlapping provisions</p>	<table border="1"> <thead> <tr> <th></th> <th>TAC</th> <th>Commission</th> </tr> </thead> <tbody> <tr> <td><input type="checkbox"/> No Action Needed</td> <td><input type="checkbox"/></td> <td><input type="checkbox"/></td> </tr> <tr> <td><input type="checkbox"/> Overlapping provisions</td> <td><input type="checkbox"/></td> <td><input type="checkbox"/></td> </tr> </tbody> </table>		TAC	Commission	<input type="checkbox"/> No Action Needed	<input type="checkbox"/>	<input type="checkbox"/>	<input type="checkbox"/> Overlapping provisions	<input type="checkbox"/>	<input type="checkbox"/>
	TAC	Commission											
<input type="checkbox"/> No Action Needed	<input type="checkbox"/>	<input type="checkbox"/>											
<input type="checkbox"/> Overlapping provisions	<input type="checkbox"/>	<input type="checkbox"/>											

Rule 61G20-2.002 2. Technical amendments needed to accommodate the specific needs of this state include but are not limited to amendments to the Florida Building Code that provide for the following:

a. Establish minimum life safety construction requirements to protect buildings and their occupants from fire, wind, flood, and storm surge using the latest technical research and engineering standards for buildings and materials products. b. Provide for flood protection provisions that are consistent with the latest flood protection requirements of the National Flood Insurance Program. c. Maintain eligibility for federal funding and discounts from the National Flood Insurance Program, the Federal Emergency Management Agency, and the United States Department of Housing and Urban Development. d. Provide for energy efficiency standards for buildings that meet or exceed the national energy standards as mandated by Title III of the Energy Conservation and Protection Act. e. Maintain coordination with the Florida Fire Prevention Code. f. Provide for the latest industry standards and design

RB192-16	R502.6	<p>Modifies text of Section R502.6 “Bearing”. Change provides better organization of this section for current construction techniques and clarification.</p> <p>Cost Impact: Will not increase the cost of construction.</p>	Same as change between 2015 IRC-B and 2018 IRC-B	<p>No action needed</p> <p>As per R301.2.1.1 of the 2017 FRC, this section is part of those prescriptive provisions that are not applicable to Florida.</p>
----------	--------	---	--	--

<p>RCCIWG – Comment</p> <p>Impactful (Explain) <input type="checkbox"/></p>	<p>TAC Action</p> <p>Accommodate Florida Specific Need: YES (Select Criteria) <input type="checkbox"/> NO: <input type="checkbox"/> a. <input type="checkbox"/> b. <input type="checkbox"/> c. <input type="checkbox"/> d. <input type="checkbox"/> e. <input type="checkbox"/> f. <input type="checkbox"/> Others (Explain):</p>	<p>Commission Action</p> <p>Accommodate Florida Specific Need: YES (Select Criteria) <input type="checkbox"/> NO: <input type="checkbox"/> a. <input type="checkbox"/> b. <input type="checkbox"/> c. <input type="checkbox"/> d. <input type="checkbox"/> e. <input type="checkbox"/> f. <input type="checkbox"/> Others (Explain):</p>	<p><input type="checkbox"/> No Action Needed</p> <p><input type="checkbox"/> Overlapping provisions</p>	<p>TAC</p> <p><input type="checkbox"/></p>	<p>Commission</p> <p><input type="checkbox"/></p>
--	---	--	---	---	--

RB195-16	R505, R505.1.1, R505.1.3, R505.2.6.2, R505.3.2, R505.3.7	<p>Modifies text of Section R505.1.1 “Applicability limits”, R505.1.3 “Floor trusses”, R505.2.6.2 “Web hole reinforcing”, R505.3.7 “Splicing”. Modifies text of Table R505.3.2 “ALLOWABLE SPANS FOR COLD-FORMED STEEL JOISTS—SINGLE OR CONTINUOUS SPANS”. Adds new standard “AISI S240-15, North American Standard for Cold-Formed Steel Structural Framing (2015)”. This proposal is intended to update the content of the Cold-Formed Steel (CFS) light-framed construction provisions of the IRC.</p> <p>Cost Impact: Will increase the cost of construction. The proposed changes to this section will not increase the cost of construction in general. While the overwhelming majority of the prescribed members have not changed or are reduced in size, there may be conditions for which the minimum member size will increase.</p>	Same as change between 2015 IRC-B and 2018 IRC-B	<p>No action needed</p> <p>As per R301.2.1.1 of the 2017 FRC, these sections are part of those prescriptive provisions that are not applicable to Florida.</p>
----------	--	---	--	---

<p>RCCIWG – Comment</p> <p>Impactful (Explain) <input type="checkbox"/></p>	<p>TAC Action</p> <p>Accommodate Florida Specific Need: YES (Select Criteria) <input type="checkbox"/> NO: <input type="checkbox"/> a. <input type="checkbox"/> b. <input type="checkbox"/> c. <input type="checkbox"/> d. <input type="checkbox"/> e. <input type="checkbox"/> f. <input type="checkbox"/> Others (Explain):</p>	<p>Commission Action</p> <p>Accommodate Florida Specific Need: YES (Select Criteria) <input type="checkbox"/> NO: <input type="checkbox"/> a. <input type="checkbox"/> b. <input type="checkbox"/> c. <input type="checkbox"/> d. <input type="checkbox"/> e. <input type="checkbox"/> f. <input type="checkbox"/> Others (Explain):</p>	<p><input type="checkbox"/> No Action Needed</p> <p><input type="checkbox"/> Overlapping provisions</p>	<p>TAC</p> <p><input type="checkbox"/></p>	<p>Commission</p> <p><input type="checkbox"/></p>
--	---	--	---	---	--

Rule 61G20-2.002 2. Technical amendments needed to accommodate the specific needs of this state include but are not limited to amendments to the Florida Building Code that provide for the following:

a. Establish minimum life safety construction requirements to protect buildings and their occupants from fire, wind, flood, and storm surge using the latest technical research and engineering standards for buildings and materials products. b. Provide for flood protection provisions that are consistent with the latest flood protection requirements of the National Flood Insurance Program. c. Maintain eligibility for federal funding and discounts from the National Flood Insurance Program, the Federal Emergency Management Agency, and the United States Department of Housing and Urban Development. d. Provide for energy efficiency standards for buildings that meet or exceed the national energy standards as mandated by Title III of the Energy Conservation and Protection Act. e. Maintain coordination with the Florida Fire Prevention Code. f. Provide for the latest industry standards and design

<p>RB198-16</p>	<p>507.3.5, R507, R507.1, R507.2, R507.2.1, R507.2.2, R507.2.3, R507.2.4, R507.3, R507.3 (New), R507.3.1, R507.3.2, R507.3.3, R507.3.4, R507.4, R507.5, R507.5.1, R507.6, R507.7, R507.7.1, R507.8, R507.8 (New), R507.8.1, R507.8.1 (New)</p>	<p>Revises section R507.1 “Decks”. Modifies text of Sections R507. R507.2 “Plastic composite deck boards, stair treads, guards, or handrails”, R507.2.1 “Labeling”, R507.2.2 “Flame spread index”, R507.2.3 “Decay resistance”, R507.2.4 “Termite resistance”, R507.2.5 “Installation of plastic composites”, R507.4 “Deck posts”, R507.4.1 “Deck post to deck footing”, R507.5 “Deck Beams”, R507.5.1 “Deck post to deck beam”, R507.6 “Deck joists”, R507.6.1 “Lateral restraint at supports”, R507.6.2 “Deck joist and deck beam bearing”, R507.7 “Decking”, R507.8.1.1 “Ledger details”, R507.8.1.2 “Band joist details”, R507.8.1.3 “Ledger to band joist fastener details”, R507.8.2 “Deck lateral load connection”. Adds new Section R507.3 “Deck footings”. R507.8 “Vertical and lateral supports”, R507.8.1 “Vertical supports”.</p> <p>Modifies Figure R507.3 “TYPICAL DECK POSTS TO DECK FOOTINGS” and Figure R507.5 “Typical Deck Beam Spans”, R507.5.1 “DECK BEAM TO DECK POST”, R507.6 “TYPICAL DECK JOIST SPANS”, R507.8.1.3(2) “PLACEMENT OF LAG SCREWS AND BOLTS IN BAND JOISTS”, R507.8.1.3(1) “PLACEMENT OF LAG SCREWS AND BOLTS IN LEDGERS”, R507.8.2(2) “DECK ATTACHMENT FOR LATERAL LOADS”, R507.8.2(1) “DECK ATTACHMENT FOR LATERAL LOADS”. Modifies table R507.4 “DECK POST HEIGHT”, Table R507.5 “DECK BEAM SPAN LENGTHS”, R507.6 “DECK JOIST SPANS FOR COMMON LUMBER SPECIES”, Table R507.7 “MAXIMUM JOIST SPACING”, TABLE R507.8.1.3(1) “DECK LEDGER CONNECTION TO BAND JOIST”, R507.8.1.3(2) “PLACEMENT OF LAG SCREWS AND BOLTS IN DECK LEDGERS AND BAND JOISTS.” The entire section is reorganized without any technical changes, based on similar organization in the IRC, namely, starting at the footings and working upward.</p> <p>Cost Impact: Will not increase the cost of construction. There should be no cost impact, as this is purely a non-technical code change.</p>	<p>Same as change between 2015 IRC-B and 2018 IRC-B</p>	
-----------------	--	--	---	--

Rule 61G20-2.002 2. Technical amendments needed to accommodate the specific needs of this state include but are not limited to amendments to the Florida Building Code that provide for the following: a. Establish minimum life safety construction requirements to protect buildings and their occupants from fire, wind, flood, and storm surge using the latest technical research and engineering standards for buildings and materials products. b. Provide for flood protection provisions that are consistent with the latest flood protection requirements of the National Flood Insurance Program. c. Maintain eligibility for federal funding and discounts from the National Flood Insurance Program, the Federal Emergency Management Agency, and the United States Department of Housing and Urban Development. d. Provide for energy efficiency standards for buildings that meet or exceed the national energy standards as mandated by Title III of the Energy Conservation and Protection Act. e. Maintain coordination with the Florida Fire Prevention Code. f. Provide for the latest industry standards and design

RCCIWG – Comment		TAC Action	Commission Action		TAC	Commission
Impactful (Explain) <input type="checkbox"/>		Accommodate Florida Specific Need: YES (Select Criteria) <input type="checkbox"/> NO: <input type="checkbox"/> a. <input type="checkbox"/> b. <input type="checkbox"/> c. <input type="checkbox"/> d. <input type="checkbox"/> e. <input type="checkbox"/> f. <input type="checkbox"/> Others (Explain): <input type="text"/>	Accommodate Florida Specific Need: YES (Select Criteria) <input type="checkbox"/> NO: <input type="checkbox"/> a. <input type="checkbox"/> b. <input type="checkbox"/> c. <input type="checkbox"/> d. <input type="checkbox"/> e. <input type="checkbox"/> f. <input type="checkbox"/> Others (Explain): <input type="text"/>	<input type="checkbox"/> No Action Needed <input type="checkbox"/> Overlapping provisions	<input type="checkbox"/>	<input type="checkbox"/>
RB200-16	R507, R507.5.1(2) (New), R507.6, R507.7, R507.7.1	Modifies text of Section R507.5 “Deck Beams”, R507.5.1 “Deck”, R507.5.2 “Deck beam connections to supports”, Table R507.5 “DECK BEAM SPAN LENGTHS”. Modified Figure R507.5.1(1) “TYPICAL DECK BEAM TO DECK POST CONNECTION”, Figure R507.5.1(2) “NOTCHED POST-TO-BEAM CONNECTION”, FIGURE R507.5 “TYPICAL DECK”. Moves together sections R507.6, R507.7 and R507.1 into a new section BEAMS. Provides new figures and updates table. The code change was further modified by public comment to correct an improper word choice in the original proposal. Cost Impact: Will not increase the cost of construction. There is no cost impact. It may even save a few dollars by allowing single ply beams.	Same as change between 2015 IRC-B and 2018 IRC-B			
Impactful (Explain) <input type="checkbox"/>		Accommodate Florida Specific Need: YES (Select Criteria) <input type="checkbox"/> NO: <input type="checkbox"/> a. <input type="checkbox"/> b. <input type="checkbox"/> c. <input type="checkbox"/> d. <input type="checkbox"/> e. <input type="checkbox"/> f. <input type="checkbox"/> Others (Explain): <input type="text"/>	Accommodate Florida Specific Need: YES (Select Criteria) <input type="checkbox"/> NO: <input type="checkbox"/> a. <input type="checkbox"/> b. <input type="checkbox"/> c. <input type="checkbox"/> d. <input type="checkbox"/> e. <input type="checkbox"/> f. <input type="checkbox"/> Others (Explain): <input type="text"/>	<input type="checkbox"/> No Action Needed <input type="checkbox"/> Overlapping provisions	<input type="checkbox"/>	<input type="checkbox"/>
RB202-16	507.3.5, R507, R507.2 (New), R507.2.1 (New), R507.2.1.1 (New), R507.2.3 (New), R507.2.4	Adds new sections to Section R507 “Exterior Decks”. Adds new section R507.2 “Materials”, R507.2.1 “Wood materials”, R507.2.1.1 “Engineered wood products”, R507.2.3 “Fasteners and connectors”, R507.2.4 “Flashing”, R507.2.5 “Alternate materials”. Adds new table R507.2.3 “FASTENER AND CONNECTOR SPECIFICATIONS FOR DECKS”. Modifies text of R507.2.2 “Plastic composite deck boards, stair treads, guards, or handrails”, R507.2.2.1 “Labeling”, R507.2.2.2 “Flame spread index”, R507.2.2.3 “Decay resistance”, R507.2.2.4	Same as change between 2015 IRC-B and 2018 IRC-B			

Rule 61G20-2.002 2. Technical amendments needed to accommodate the specific needs of this state include but are not limited to amendments to the Florida Building Code that provide for the following: a. Establish minimum life safety construction requirements to protect buildings and their occupants from fire, wind, flood, and storm surge using the latest technical research and engineering standards for buildings and materials products. b. Provide for flood protection provisions that are consistent with the latest flood protection requirements of the National Flood Insurance Program. c. Maintain eligibility for federal funding and discounts from the National Flood Insurance Program, the Federal Emergency Management Agency, and the United States Department of Housing and Urban Development. d. Provide for energy efficiency standards for buildings that meet or exceed the national energy standards as mandated by Title III of the Energy Conservation and Protection Act. e. Maintain coordination with the Florida Fire Prevention Code. f. Provide for the latest industry standards and design

	<p>(New), R507.2.5 (New), R507.3, R507.3.1, R507.3.2, R507.3.3, R507.3.4</p>	<p>"Termite resistance", R507.2.2.5 "Installation of plastic composites".</p> <p>This code change proposal provides design specifications for deck construction materials frequently found in deck construction. Includes design specifications for wood, fasteners and other materials. The code change was further modified by the Committee. The modification changes alternate to equivalent which is the more appropriate terminology.</p> <p>Cost Impact: Will not increase the cost of construction. There is no cost impact. These materials are already required by other sections of the IRC for connecting members outdoors.</p>		
--	--	---	--	--

RCCIWG – Comment	TAC Action	Commission Action		TAC	Commission
<p>Impactful (Explain) <input type="checkbox"/></p>	<p>Accommodate Florida Specific Need: YES (Select Criteria) <input type="checkbox"/> NO: <input type="checkbox"/> a. <input type="checkbox"/> b. <input type="checkbox"/> c. <input type="checkbox"/> d. <input type="checkbox"/> e. <input type="checkbox"/> f. <input type="checkbox"/> Others (Explain): <input type="text"/></p>	<p>Accommodate Florida Specific Need: YES (Select Criteria) <input type="checkbox"/> NO: <input type="checkbox"/> a. <input type="checkbox"/> b. <input type="checkbox"/> c. <input type="checkbox"/> d. <input type="checkbox"/> e. <input type="checkbox"/> f. <input type="checkbox"/> Others (Explain): <input type="text"/></p>	<p><input type="checkbox"/> No Action Needed</p> <p><input type="checkbox"/> Overlapping provisions</p>	<p><input type="checkbox"/></p> <p><input type="checkbox"/></p>	<p><input type="checkbox"/></p> <p><input type="checkbox"/></p>

<p>RB203-16</p>	<p>R507, R507.2, R507.2.1, R507.2.2, R507.2.3, R507.2.4, R507.9.1 (New), R507.9.1.4 (New)</p>	<p>Modifies text of Section 507 "Exterior Decks". R507.9 "Vertical and lateral supports at band joist", R507.9.1 "Vertical supports", R507.9.1.1 "Ledger details", R507.9.1.2 "Band joist details", R507.9.1.3 "Ledger to band joist details", R507.9.1.4 "Alternate ledger details", R507.9.2 "Lateral connection." Adds Table R507.9.1.3(1) "DECK LEDGER CONNECTION TO BAND JOIST", Table R507.9.1.3.(2) "PLACEMENT OF LAG SCREWS AND BOLTS IN DECK LEDGERS AND BAND JOISTS". Modifies Figure R507.9.1.3(1) "PLACEMENT OF LAG SCREWS AND BOLTS IN LEDGERS", Figure R507.9.1.3(2) "PLACEMENT OF LAG SCREWS AND BOLTS IN BAND JOISTS", Figure R507.9.2(1) "DECK ATTACHMENT FOR LATERAL LOADS", R507.9.2(2) "DECK ATTACHMENT FOR LATERAL LOADS".</p> <p>This code change moves the deck ledger attachment and lateral resistance details from Section R507. 2 to the end of the</p>	<p>Same as change between 2015 IRC-B and 2018 IRC-B</p>	
-----------------	---	---	---	--

Rule 61G20-2.002 2. Technical amendments needed to accommodate the specific needs of this state include but are not limited to amendments to the Florida Building Code that provide for the following: a. Establish minimum life safety construction requirements to protect buildings and their occupants from fire, wind, flood, and storm surge using the latest technical research and engineering standards for buildings and materials products. b. Provide for flood protection provisions that are consistent with the latest flood protection requirements of the National Flood Insurance Program. c. Maintain eligibility for federal funding and discounts from the National Flood Insurance Program, the Federal Emergency Management Agency, and the United States Department of Housing and Urban Development. d. Provide for energy efficiency standards for buildings that meet or exceed the national energy standards as mandated by Title III of the Energy Conservation and Protection Act. e. Maintain coordination with the Florida Fire Prevention Code. f. Provide for the latest industry standards and design

		<p>section.</p> <p>Cost Impact: Will not increase the cost of construction. There is no cost impact. This is a non-technical code change - it only moved the requirements from R507.2 to the end of the section.</p>											
<p>RCCIWG – Comment</p> <p>Impactful (Explain) <input type="checkbox"/></p>		<p>TAC Action</p> <p>Accommodate Florida Specific Need: YES (Select Criteria) <input type="checkbox"/> NO: <input type="checkbox"/></p> <p>a. <input type="checkbox"/> b. <input type="checkbox"/> c. <input type="checkbox"/> d. <input type="checkbox"/> e. <input type="checkbox"/> f. <input type="checkbox"/></p> <p>Others (Explain):</p>	<p>Commission Action</p> <p>Accommodate Florida Specific Need: YES (Select Criteria) <input type="checkbox"/> NO: <input type="checkbox"/></p> <p>a. <input type="checkbox"/> b. <input type="checkbox"/> c. <input type="checkbox"/> d. <input type="checkbox"/> e. <input type="checkbox"/> f. <input type="checkbox"/></p> <p>Others (Explain):</p>	<table border="1"> <thead> <tr> <th></th> <th>TAC</th> <th>Commission</th> </tr> </thead> <tbody> <tr> <td><input type="checkbox"/> No Action Needed</td> <td><input type="checkbox"/></td> <td><input type="checkbox"/></td> </tr> <tr> <td><input type="checkbox"/> Overlapping provisions</td> <td><input type="checkbox"/></td> <td><input type="checkbox"/></td> </tr> </tbody> </table>		TAC	Commission	<input type="checkbox"/> No Action Needed	<input type="checkbox"/>	<input type="checkbox"/>	<input type="checkbox"/> Overlapping provisions	<input type="checkbox"/>	<input type="checkbox"/>
	TAC	Commission											
<input type="checkbox"/> No Action Needed	<input type="checkbox"/>	<input type="checkbox"/>											
<input type="checkbox"/> Overlapping provisions	<input type="checkbox"/>	<input type="checkbox"/>											
RB205-16	R507, R507.3 (New), R507.3.1 (New), R507.3.2 (New)	<p>Adds new Sections R507.3 “Footings”, R507.3.1 “Minimum size”, R507.3.2 “Minimum depth”. This code change provides an exception for "freestanding wood patios" from having to comply with the requirement in R403 footings below frost line. It will allow a freestanding deck to be totally supported on the ground without any footings. The code change was further modified by the Committee. The modification moves the exception to the proper section.</p> <p>Cost Impact: Will not increase the cost of construction. There is no cost impact. The code already provides an exception for footings below the frost line in Section R403.1.4.1 for freestanding decks.</p>	Same as change between 2015 IRC-B and 2018 IRC-B										
<p>RCCIWG – Comment</p> <p>Impactful (Explain) <input type="checkbox"/></p>		<p>TAC Action</p> <p>Accommodate Florida Specific Need: YES (Select Criteria) <input type="checkbox"/> NO: <input type="checkbox"/></p> <p>a. <input type="checkbox"/> b. <input type="checkbox"/> c. <input type="checkbox"/> d. <input type="checkbox"/> e. <input type="checkbox"/> f. <input type="checkbox"/></p> <p>Others (Explain):</p>	<p>Commission Action</p> <p>Accommodate Florida Specific Need: YES (Select Criteria) <input type="checkbox"/> NO: <input type="checkbox"/></p> <p>a. <input type="checkbox"/> b. <input type="checkbox"/> c. <input type="checkbox"/> d. <input type="checkbox"/> e. <input type="checkbox"/> f. <input type="checkbox"/></p> <p>Others (Explain):</p>	<table border="1"> <thead> <tr> <th></th> <th>TAC</th> <th>Commission</th> </tr> </thead> <tbody> <tr> <td><input type="checkbox"/> No Action Needed</td> <td><input type="checkbox"/></td> <td><input type="checkbox"/></td> </tr> <tr> <td><input type="checkbox"/> Overlapping provisions</td> <td><input type="checkbox"/></td> <td><input type="checkbox"/></td> </tr> </tbody> </table>		TAC	Commission	<input type="checkbox"/> No Action Needed	<input type="checkbox"/>	<input type="checkbox"/>	<input type="checkbox"/> Overlapping provisions	<input type="checkbox"/>	<input type="checkbox"/>
	TAC	Commission											
<input type="checkbox"/> No Action Needed	<input type="checkbox"/>	<input type="checkbox"/>											
<input type="checkbox"/> Overlapping provisions	<input type="checkbox"/>	<input type="checkbox"/>											
RB206-16	R507, R507.3 (New), R507.3.1 (New),	<p>Adds new Sections R507.3 “Footing”, R507.3.1 “Minimum size”, R507.3.2 “Minimum depth”. This code change provides the specifications for when a freestanding deck can be constructed on precast concrete pier blocks at grade.</p>	Same as change between 2015 IRC-B and 2018 IRC-B										

Rule 61G20-2.002 2. Technical amendments needed to accommodate the specific needs of this state include but are not limited to amendments to the Florida Building Code that provide for the following: a. Establish minimum life safety construction requirements to protect buildings and their occupants from fire, wind, flood, and storm surge using the latest technical research and engineering standards for buildings and materials products. b. Provide for flood protection provisions that are consistent with the latest flood protection requirements of the National Flood Insurance Program. c. Maintain eligibility for federal funding and discounts from the National Flood Insurance Program, the Federal Emergency Management Agency, and the United States Department of Housing and Urban Development. d. Provide for energy efficiency standards for buildings that meet or exceed the national energy standards as mandated by Title III of the Energy Conservation and Protection Act. e. Maintain coordination with the Florida Fire Prevention Code. f. Provide for the latest industry standards and design

	R507.3.2 (New)	<p>Cost Impact: Will not increase the cost of construction. There is no cost impact. The builder was always required to provide deck footings in accordance with Section 4. In fact it might actually reduce the cost by giving prescriptive acceptance for footings on concrete pier blocks.</p>											
RCCIWG – Comment Impactful (Explain) <input type="checkbox"/>		TAC Action Accommodate Florida Specific Need: YES (Select Criteria) <input type="checkbox"/> NO: <input type="checkbox"/> a. <input type="checkbox"/> b. <input type="checkbox"/> c. <input type="checkbox"/> d. <input type="checkbox"/> e. <input type="checkbox"/> f. <input type="checkbox"/> Others (Explain): <input type="text"/>	Commission Action Accommodate Florida Specific Need: YES (Select Criteria) <input type="checkbox"/> NO: <input type="checkbox"/> a. <input type="checkbox"/> b. <input type="checkbox"/> c. <input type="checkbox"/> d. <input type="checkbox"/> e. <input type="checkbox"/> f. <input type="checkbox"/> Others (Explain): <input type="text"/>	<table border="1"> <tr> <td></td> <td>TAC</td> <td>Commission</td> </tr> <tr> <td><input type="checkbox"/> No Action Needed</td> <td><input type="checkbox"/></td> <td><input type="checkbox"/></td> </tr> <tr> <td><input type="checkbox"/> Overlapping provisions</td> <td><input type="checkbox"/></td> <td><input type="checkbox"/></td> </tr> </table>		TAC	Commission	<input type="checkbox"/> No Action Needed	<input type="checkbox"/>	<input type="checkbox"/>	<input type="checkbox"/> Overlapping provisions	<input type="checkbox"/>	<input type="checkbox"/>
	TAC	Commission											
<input type="checkbox"/> No Action Needed	<input type="checkbox"/>	<input type="checkbox"/>											
<input type="checkbox"/> Overlapping provisions	<input type="checkbox"/>	<input type="checkbox"/>											
RB207-16	R507, R507.3 (New), R507.3.1 (New), R507.3.2 (New), TABLE R507.3.1 (New)	<p>Adds new section R507.3 “Footings”, R507.3.1 “Minimum size”, R507.3.2 “Minimum depth”. Adds new Table R507.3.1 “MINIMUM FOOTING SIZE FOR DECKS”. This code change provides prescriptive language and a table for determining the minimum size and depth of deck footings based on tributary area, live load and soil bearing pressure. It provides the size based on either square or cylindrical footings.</p> <p>Cost Impact: Will not increase the cost of construction. If deck footings were correctly sized in the past, there will not be a cost increase based on this table.</p>	Same as change between 2015 IRC-B and 2018 IRC-B										
RCCIWG – Comment Impactful (Explain) <input type="checkbox"/>		TAC Action Accommodate Florida Specific Need: YES (Select Criteria) <input type="checkbox"/> NO: <input type="checkbox"/> a. <input type="checkbox"/> b. <input type="checkbox"/> c. <input type="checkbox"/> d. <input type="checkbox"/> e. <input type="checkbox"/> f. <input type="checkbox"/> Others (Explain): <input type="text"/>	Commission Action Accommodate Florida Specific Need: YES (Select Criteria) <input type="checkbox"/> NO: <input type="checkbox"/> a. <input type="checkbox"/> b. <input type="checkbox"/> c. <input type="checkbox"/> d. <input type="checkbox"/> e. <input type="checkbox"/> f. <input type="checkbox"/> Others (Explain): <input type="text"/>	<table border="1"> <tr> <td></td> <td>TAC</td> <td>Commission</td> </tr> <tr> <td><input type="checkbox"/> No Action Needed</td> <td><input type="checkbox"/></td> <td><input type="checkbox"/></td> </tr> <tr> <td><input type="checkbox"/> Overlapping provisions</td> <td><input type="checkbox"/></td> <td><input type="checkbox"/></td> </tr> </table>		TAC	Commission	<input type="checkbox"/> No Action Needed	<input type="checkbox"/>	<input type="checkbox"/>	<input type="checkbox"/> Overlapping provisions	<input type="checkbox"/>	<input type="checkbox"/>
	TAC	Commission											
<input type="checkbox"/> No Action Needed	<input type="checkbox"/>	<input type="checkbox"/>											
<input type="checkbox"/> Overlapping provisions	<input type="checkbox"/>	<input type="checkbox"/>											
RB208-16	R507, R507.3 (New), R507.3.1 (New), R507.3.2 (New)	<p>Added text of Section R507.3 “Footings”, R507.3.1 “Minimum size”, R507.3.2 “Minimum depth”. This code change provides prescriptive language for where the minimum size and depth of deck footings can be found, namely in Chapter 4. It also copies an exception from R403.1.4.</p>	Same as change between 2015 IRC-B and 2018 IRC-B										

Rule 61G20-2.002 2. Technical amendments needed to accommodate the specific needs of this state include but are not limited to amendments to the Florida Building Code that provide for the following: a. Establish minimum life safety construction requirements to protect buildings and their occupants from fire, wind, flood, and storm surge using the latest technical research and engineering standards for buildings and materials products. b. Provide for flood protection provisions that are consistent with the latest flood protection requirements of the National Flood Insurance Program. c. Maintain eligibility for federal funding and discounts from the National Flood Insurance Program, the Federal Emergency Management Agency, and the United States Department of Housing and Urban Development. d. Provide for energy efficiency standards for buildings that meet or exceed the national energy standards as mandated by Title III of the Energy Conservation and Protection Act. e. Maintain coordination with the Florida Fire Prevention Code. f. Provide for the latest industry standards and design

		<p>Cost Impact: Will not increase the cost of construction. There will not be a cost impact. This code change does not alter the way deck footings have been sized under the current code</p>											
<p>RCCIWG – Comment</p> <p>Impactful (Explain) <input type="checkbox"/></p>		<p>TAC Action</p> <p>Accommodate Florida Specific Need: YES (Select Criteria) <input type="checkbox"/> NO: <input type="checkbox"/> a. <input type="checkbox"/> b. <input type="checkbox"/> c. <input type="checkbox"/> d. <input type="checkbox"/> e. <input type="checkbox"/> f. <input type="checkbox"/> Others (Explain):</p>	<p>Commission Action</p> <p>Accommodate Florida Specific Need: YES (Select Criteria) <input type="checkbox"/> NO: <input type="checkbox"/> a. <input type="checkbox"/> b. <input type="checkbox"/> c. <input type="checkbox"/> d. <input type="checkbox"/> e. <input type="checkbox"/> f. <input type="checkbox"/> Others (Explain):</p>	<table border="1"> <tr> <td></td> <td>TAC</td> <td>Commission</td> </tr> <tr> <td><input type="checkbox"/> No Action Needed</td> <td><input type="checkbox"/></td> <td><input type="checkbox"/></td> </tr> <tr> <td><input type="checkbox"/> Overlapping provisions</td> <td><input type="checkbox"/></td> <td><input type="checkbox"/></td> </tr> </table>		TAC	Commission	<input type="checkbox"/> No Action Needed	<input type="checkbox"/>	<input type="checkbox"/>	<input type="checkbox"/> Overlapping provisions	<input type="checkbox"/>	<input type="checkbox"/>
	TAC	Commission											
<input type="checkbox"/> No Action Needed	<input type="checkbox"/>	<input type="checkbox"/>											
<input type="checkbox"/> Overlapping provisions	<input type="checkbox"/>	<input type="checkbox"/>											
RB209-16	R507, R507.4	<p>Modifies text of Section R507.7 “Decking”. Modifies text of R507.7 “MAXIMUM JOIST SPACING FOR DECKING”. This code change modifies the decking text to permit custom decking materials and custom fasteners.</p> <p>Cost Impact: Will not increase the cost of construction. There is no cost impact. It may even save a bit by allowing proprietary fastening systems.</p>	Same as change between 2015 IRC-B and 2018 IRC-B										
<p>RCCIWG – Comment</p> <p>Impactful (Explain) <input type="checkbox"/></p>		<p>TAC Action</p> <p>Accommodate Florida Specific Need: YES (Select Criteria) <input type="checkbox"/> NO: <input type="checkbox"/> a. <input type="checkbox"/> b. <input type="checkbox"/> c. <input type="checkbox"/> d. <input type="checkbox"/> e. <input type="checkbox"/> f. <input type="checkbox"/> Others (Explain):</p>	<p>Commission Action</p> <p>Accommodate Florida Specific Need: YES (Select Criteria) <input type="checkbox"/> NO: <input type="checkbox"/> a. <input type="checkbox"/> b. <input type="checkbox"/> c. <input type="checkbox"/> d. <input type="checkbox"/> e. <input type="checkbox"/> f. <input type="checkbox"/> Others (Explain):</p>	<table border="1"> <tr> <td></td> <td>TAC</td> <td>Commission</td> </tr> <tr> <td><input type="checkbox"/> No Action Needed</td> <td><input type="checkbox"/></td> <td><input type="checkbox"/></td> </tr> <tr> <td><input type="checkbox"/> Overlapping provisions</td> <td><input type="checkbox"/></td> <td><input type="checkbox"/></td> </tr> </table>		TAC	Commission	<input type="checkbox"/> No Action Needed	<input type="checkbox"/>	<input type="checkbox"/>	<input type="checkbox"/> Overlapping provisions	<input type="checkbox"/>	<input type="checkbox"/>
	TAC	Commission											
<input type="checkbox"/> No Action Needed	<input type="checkbox"/>	<input type="checkbox"/>											
<input type="checkbox"/> Overlapping provisions	<input type="checkbox"/>	<input type="checkbox"/>											
RB210-16	R507, R507.5, R507.5.1, R507.7	<p>Modifies text of Section R507.6 “Deck joists”, R507.6.1 “Deck joist”, R507.6.2 “Deck joist lateral restraint”. Modifies Table R507.6 “DECK JOIST SPANS FOR COMMON LUMBER SPECIES”. Adds Figure R507.6 “Typical Deck Joist Spans”. Modifies the joist text, replaces the figure, and amends a table.</p> <p>Cost Impact: Will not increase the cost of construction. There is no cost impact. It could allow for longer cantilevers in some situations.</p>	Same as change between 2015 IRC-B and 2018 IRC-B										

Rule 61G20-2.002 2. Technical amendments needed to accommodate the specific needs of this state include but are not limited to amendments to the Florida Building Code that provide for the following: a. Establish minimum life safety construction requirements to protect buildings and their occupants from fire, wind, flood, and storm surge using the latest technical research and engineering standards for buildings and materials products. b. Provide for flood protection provisions that are consistent with the latest flood protection requirements of the National Flood Insurance Program. c. Maintain eligibility for federal funding and discounts from the National Flood Insurance Program, the Federal Emergency Management Agency, and the United States Department of Housing and Urban Development. d. Provide for energy efficiency standards for buildings that meet or exceed the national energy standards as mandated by Title III of the Energy Conservation and Protection Act. e. Maintain coordination with the Florida Fire Prevention Code. f. Provide for the latest industry standards and design

RCCIWG – Comment		TAC Action	Commission Action		TAC	Commission
Impactful (Explain) <input type="checkbox"/>		Accommodate Florida Specific Need: YES (Select Criteria) <input type="checkbox"/> NO: <input type="checkbox"/> a. <input type="checkbox"/> b. <input type="checkbox"/> c. <input type="checkbox"/> d. <input type="checkbox"/> e. <input type="checkbox"/> f. <input type="checkbox"/> Others (Explain): 	Accommodate Florida Specific Need: YES (Select Criteria) <input type="checkbox"/> NO: <input type="checkbox"/> a. <input type="checkbox"/> b. <input type="checkbox"/> c. <input type="checkbox"/> d. <input type="checkbox"/> e. <input type="checkbox"/> f. <input type="checkbox"/> Others (Explain): 	<input type="checkbox"/> No Action Needed <input type="checkbox"/> Overlapping provisions	<input type="checkbox"/>	<input type="checkbox"/>
RB212-16	R507, R507.8, R507.8.1	Modifies text of Section R507.4 “Deck posts”, R507.4.1 “Deck post to deck footing connection”. Modifies Table R507.4 “DECK POST HEIGHT”. Modifies Figure R507.4.1 “TYPICAL DECK POSTS TO DECK FOOTINGS”. This code proposal relocates the deck post section. Also, it adds 8x8 posts to the table. Cost Impact: Will not increase the cost of construction. There is no cost impact. This proposal adds more options to the table.		Same as change between 2015 IRC-B and 2018 IRC-B		
Impactful (Explain) <input type="checkbox"/>		Accommodate Florida Specific Need: YES (Select Criteria) <input type="checkbox"/> NO: <input type="checkbox"/> a. <input type="checkbox"/> b. <input type="checkbox"/> c. <input type="checkbox"/> d. <input type="checkbox"/> e. <input type="checkbox"/> f. <input type="checkbox"/> Others (Explain): 	Accommodate Florida Specific Need: YES (Select Criteria) <input type="checkbox"/> NO: <input type="checkbox"/> a. <input type="checkbox"/> b. <input type="checkbox"/> c. <input type="checkbox"/> d. <input type="checkbox"/> e. <input type="checkbox"/> f. <input type="checkbox"/> Others (Explain): 	<input type="checkbox"/> No Action Needed <input type="checkbox"/> Overlapping provisions	<input type="checkbox"/>	<input type="checkbox"/>
RB213-16	R507.8, R507.8.1	Modifies text of Section R507.4 “Deck posts”, R507.4.1 “Deck post to deck footing”. Modifies Table R507.4 “Deck Post Height”. Modifies Figure R507.4.1 “TYPICAL DECK POSTS TO DECK FOOTINGS”. This code proposal relocates the deck post section also adds an exception that says deck posts cannot use embedded soil for lateral support if the surrounding soils are problematic. Modifies Figure. Cost Impact: Will not increase the cost of construction. There is no cost impact. The code already requires lateral restraint at the bottom of the footings.		Same as change between 2015 IRC-B and 2018 IRC-B		

Rule 61G20-2.002 2. Technical amendments needed to accommodate the specific needs of this state include but are not limited to amendments to the Florida Building Code that provide for the following: a. Establish minimum life safety construction requirements to protect buildings and their occupants from fire, wind, flood, and storm surge using the latest technical research and engineering standards for buildings and materials products. b. Provide for flood protection provisions that are consistent with the latest flood protection requirements of the National Flood Insurance Program. c. Maintain eligibility for federal funding and discounts from the National Flood Insurance Program, the Federal Emergency Management Agency, and the United States Department of Housing and Urban Development. d. Provide for energy efficiency standards for buildings that meet or exceed the national energy standards as mandated by Title III of the Energy Conservation and Protection Act. e. Maintain coordination with the Florida Fire Prevention Code. f. Provide for the latest industry standards and design

RCCIWG – Comment		TAC Action	Commission Action		TAC	Commission
Impactful (Explain) <input type="checkbox"/>		Accommodate Florida Specific Need: YES (Select Criteria) <input type="checkbox"/> NO: <input type="checkbox"/> a. <input type="checkbox"/> b. <input type="checkbox"/> c. <input type="checkbox"/> d. <input type="checkbox"/> e. <input type="checkbox"/> f. <input type="checkbox"/> Others (Explain):	Accommodate Florida Specific Need: YES (Select Criteria) <input type="checkbox"/> NO: <input type="checkbox"/> a. <input type="checkbox"/> b. <input type="checkbox"/> c. <input type="checkbox"/> d. <input type="checkbox"/> e. <input type="checkbox"/> f. <input type="checkbox"/> Others (Explain):	<input type="checkbox"/> No Action Needed	<input type="checkbox"/>	<input type="checkbox"/>
				<input type="checkbox"/> Overlapping provisions	<input type="checkbox"/>	<input type="checkbox"/>
RB214-16	R507, R507.8, R507.8.1	<p>Modifies text of Section R507.4 “Deck posts”, R507.4.1 “Deck post to deck footing connection”. Modifies Table R507.4 “Deck Post Height”. Modifies Figure R507.4.1 “Deck post to deck footing connection”. This code change eliminates the wording that posts have to bear on footings. The new wording specifically allows new proprietary footing systems which may or may not have footing. This code change also provides a better drawing of how posts are to be attached to footings.</p> <p>Cost Impact: Will not increase the cost of construction. There is no cost impact. The code already requires lateral restraint at the bottom of the footings. It may actually reduce the cost by allowing optional proprietary footing systems.</p>		Same as change between 2015 IRC-B and 2018 IRC-B		
Impactful (Explain) <input type="checkbox"/>		Accommodate Florida Specific Need: YES (Select Criteria) <input type="checkbox"/> NO: <input type="checkbox"/> a. <input type="checkbox"/> b. <input type="checkbox"/> c. <input type="checkbox"/> d. <input type="checkbox"/> e. <input type="checkbox"/> f. <input type="checkbox"/> Others (Explain):	Accommodate Florida Specific Need: YES (Select Criteria) <input type="checkbox"/> NO: <input type="checkbox"/> a. <input type="checkbox"/> b. <input type="checkbox"/> c. <input type="checkbox"/> d. <input type="checkbox"/> e. <input type="checkbox"/> f. <input type="checkbox"/> Others (Explain):	<input type="checkbox"/> No Action Needed	<input type="checkbox"/>	<input type="checkbox"/>
				<input type="checkbox"/> Overlapping provisions	<input type="checkbox"/>	<input type="checkbox"/>
RB217-16	R602.1.11 (New), R610.10, R610.10.1, R610.2, R610.3, R610.3.1, R610.3.2, R610.3.3, R610.3.4, R610.3.5,	<p>Add new Section R602.1.11 “Structural insulated panels”. R610.5.3 “Panel to panel connection”, R610.5.4 “Corner framing”, R610.5.6 “Thermal barrier”. Modifies Section R610.3.2 “Lumber”, R610.3.3 “SIP screws”, R610.3.4 “Nails”, R610.4 “SIP wall panels”, R610.8 “Headers”. Modifies text of Section R610.2 “Applicability limits”, R610.5.5 “Wall bracing”. Modifies Table R610.8 “MAXIMUM SPANS FOR 11-7 /8 INCH OR DEEPER SIP HEADERS”. Adds new standards “ANSI/APA PRS 610.1. Standard for Performance-Rated Structural Insulated Panels in Wall Applications”. Delete Table R610.3 “MINIMUM PROPERTIES FOR POLYURETHANE</p>		Same as change between 2015 IRC-B and 2018 IRC-B		

Rule 61G20-2.002 2. Technical amendments needed to accommodate the specific needs of this state include but are not limited to amendments to the Florida Building Code that provide for the following: a. Establish minimum life safety construction requirements to protect buildings and their occupants from fire, wind, flood, and storm surge using the latest technical research and engineering standards for buildings and materials products. b. Provide for flood protection provisions that are consistent with the latest flood protection requirements of the National Flood Insurance Program. c. Maintain eligibility for federal funding and discounts from the National Flood Insurance Program, the Federal Emergency Management Agency, and the United States Department of Housing and Urban Development. d. Provide for energy efficiency standards for buildings that meet or exceed the national energy standards as mandated by Title III of the Energy Conservation and Protection Act. e. Maintain coordination with the Florida Fire Prevention Code. f. Provide for the latest industry standards and design

	<p>R610.3.6, R610.4, R610.4.1, R610.5, R610.5.1, R610.5.2, R610.5.3, R610.5.3 (New), R610.5.4 (New), R610.5.6 (New), R610.6, R610.7, R610.8, R610.9</p>	<p>INSULATION USED AS SIPS CORE, R610.3.2 MINIMUM PROPERTIES". Deletes Section R610.3.1 "Core", Section R610.3.2, R610.3.3 "Adhesive", Section R610.4.1 "Labeling". Delete and substitute Figure 610.5(1), Figure R610.5(2), Figure R610.5(3), Figure R610.5(5), R610.8 Connection. Deletes Figure R610.8 "TYPICAL SIP WALL PANEL-TO-PANEL CONNECTION DETAILS", R610.9 "Corner framing". R610.3.1 "Core".</p> <p>The proposal is a minor reorganization and clarification of the Structural Insulated Panels (SIPs) section. The intention is to add clarity to the proposal as it is currently written. The original SIP language was based on the HUD document Prescriptive Method for Structural Insulated Panels (SIPs) Used in Wall Systems in Residential Construction. The code change was further modified by the Committee. The modification corrects several errors that occurred during the proposal submittal process. Also, it was modified by public comment. The public comment addresses Sections R610.3. Section R610.3 was inadvertently left out of the monograph. It references the new ANSI/APA standard for SIPs panels and is the justification for the removal of the core, facers, and adhesives tables from the code as these are covered in the standard.</p> <p>Cost Impact: Will not increase the cost of construction. This proposal reorganizes the existing provisions, corrects typo errors in text and figures, and recognizes new consensus standards.</p>		
--	---	---	--	--

RCCIWG – Comment	TAC Action	Commission Action		TAC	Commission
<p>Impactful (Explain) <input type="checkbox"/></p>	<p>Accommodate Florida Specific Need: YES (Select Criteria) <input type="checkbox"/> NO: <input type="checkbox"/> a. <input type="checkbox"/> b. <input type="checkbox"/> c. <input type="checkbox"/> d. <input type="checkbox"/> e. <input type="checkbox"/> f. <input type="checkbox"/> Others (Explain):</p>	<p>Accommodate Florida Specific Need: YES (Select Criteria) <input type="checkbox"/> NO: <input type="checkbox"/> a. <input type="checkbox"/> b. <input type="checkbox"/> c. <input type="checkbox"/> d. <input type="checkbox"/> e. <input type="checkbox"/> f. <input type="checkbox"/> Others (Explain):</p>	<p><input type="checkbox"/> No Action Needed</p> <p><input type="checkbox"/> Overlapping provisions</p>		

S243-16, Part II	IRC: R606.2.3	Modifies text of Section R606.2.3 "AAC masonry". Adds new Standards ASTM C1691- 11 "Standard Specification for Unreinforced Autoclaved Aerated Concrete (AAC) Masonry Units", ASTM C1693-11 "Standard Specification for Autoclaved	Same as change between 2015 IBC-B and 2018 IBC-B	
------------------	---------------	--	--	--

Rule 61G20-2.002 2. Technical amendments needed to accommodate the specific needs of this state include but are not limited to amendments to the Florida Building Code that provide for the following: a. Establish minimum life safety construction requirements to protect buildings and their occupants from fire, wind, flood, and storm surge using the latest technical research and engineering standards for buildings and materials products. b. Provide for flood protection provisions that are consistent with the latest flood protection requirements of the National Flood Insurance Program. c. Maintain eligibility for federal funding and discounts from the National Flood Insurance Program, the Federal Emergency Management Agency, and the United States Department of Housing and Urban Development. d. Provide for energy efficiency standards for buildings that meet or exceed the national energy standards as mandated by Title III of the Energy Conservation and Protection Act. e. Maintain coordination with the Florida Fire Prevention Code. f. Provide for the latest industry standards and design

		<p>Aerated Concrete (AAC)". This proposal updates the standard for autoclaved aerated concrete by deleting a withdrawn standard and adding two new standards for this product</p> <p>Cost Impact: Will not increase the cost of construction. Revision of this section does not impact the cost of construction. The definition is not needed, and the referenced standard has been withdrawn. The change merely eliminates this error in the IBC</p>			
<p>RCCIWG – Comment</p> <p>Impactful (Explain) <input type="checkbox"/></p>	<p>TAC Action</p> <p>Accommodate Florida Specific Need: YES (Select Criteria) <input type="checkbox"/> NO: <input type="checkbox"/></p> <p>a. <input type="checkbox"/> b. <input type="checkbox"/> c. <input type="checkbox"/> d. <input type="checkbox"/> e. <input type="checkbox"/> f. <input type="checkbox"/></p> <p>Others (Explain):</p>	<p>Commission Action</p> <p>Accommodate Florida Specific Need: YES (Select Criteria) <input type="checkbox"/> NO: <input type="checkbox"/></p> <p>a. <input type="checkbox"/> b. <input type="checkbox"/> c. <input type="checkbox"/> d. <input type="checkbox"/> e. <input type="checkbox"/> f. <input type="checkbox"/></p> <p>Others (Explain):</p>	<p><input type="checkbox"/> No Action Needed</p> <p><input type="checkbox"/> Overlapping provisions</p>	<p>TAC</p> <p><input type="checkbox"/></p> <p><input type="checkbox"/></p>	<p>Commission</p> <p><input type="checkbox"/></p> <p><input type="checkbox"/></p>
<p>S245-16, Part II</p>	<p>2103.1</p>	<p>Adds new Section R606.2.6 “Adhered manufactured stone masonry veneer units”. Adds new standard ASTM C1670-16 “Standard Specification for Adhered Manufactured Stone Masonry Veneer Units”. This proposal adds a new section for adhered manufactured stone masonry veneer and brings the current standard for design and installation of the product into the IRC.</p> <p>Cost Impact: Will not increase the cost of construction. Adoption of this standard establishes minimum physical requirements for manufactured stone veneer units consistent with existing industry practices.</p>	<p>Same as change between 2015 IBC-R and 2018 IBC-R</p>		
<p>RCCIWG – Comment</p> <p>Impactful (Explain) <input type="checkbox"/></p>	<p>TAC Action</p> <p>Accommodate Florida Specific Need: YES (Select Criteria) <input type="checkbox"/> NO: <input type="checkbox"/></p> <p>a. <input type="checkbox"/> b. <input type="checkbox"/> c. <input type="checkbox"/> d. <input type="checkbox"/> e. <input type="checkbox"/> f. <input type="checkbox"/></p> <p>Others (Explain):</p>	<p>Commission Action</p> <p>Accommodate Florida Specific Need: YES (Select Criteria) <input type="checkbox"/> NO: <input type="checkbox"/></p> <p>a. <input type="checkbox"/> b. <input type="checkbox"/> c. <input type="checkbox"/> d. <input type="checkbox"/> e. <input type="checkbox"/> f. <input type="checkbox"/></p> <p>Others (Explain):</p>	<p><input type="checkbox"/> No Action Needed</p> <p><input type="checkbox"/> Overlapping provisions</p>	<p>TAC</p> <p><input type="checkbox"/></p> <p><input type="checkbox"/></p>	<p>Commission</p> <p><input type="checkbox"/></p> <p><input type="checkbox"/></p>

Rule 61G20-2.002 2. Technical amendments needed to accommodate the specific needs of this state include but are not limited to amendments to the Florida Building Code that provide for the following: a. Establish minimum life safety construction requirements to protect buildings and their occupants from fire, wind, flood, and storm surge using the latest technical research and engineering standards for buildings and materials products. b. Provide for flood protection provisions that are consistent with the latest flood protection requirements of the National Flood Insurance Program. c. Maintain eligibility for federal funding and discounts from the National Flood Insurance Program, the Federal Emergency Management Agency, and the United States Department of Housing and Urban Development. d. Provide for energy efficiency standards for buildings that meet or exceed the national energy standards as mandated by Title III of the Energy Conservation and Protection Act. e. Maintain coordination with the Florida Fire Prevention Code. f. Provide for the latest industry standards and design

S275-16, Part II	R317.3.1, R317.3.3	<p>Modifies text of Section R317.3.1 “Fasteners for preservative-treated wood”, R317.3.3 “Fasteners for fire-retardant-treated wood used in exterior applications or wet or damp locations”. The intention of this proposal is to better integrate staples into the code so that the provisions for small diameter fasteners (nail and timber rivets) also are explicitly extended to staples where applicable. The second part of this proposal is to specifically limit staples to stainless steel where exposed to high corrosion environments.</p> <p>Cost Impact: Will increase the cost of construction. Currently when staples are used in treated wood the only known available option is to use stainless steel staples. In this case there would be no cost increase in construction. For use in treated wood if staples are not presently stainless then there would be a slight cost increase, however we do not feel that these staples would be code conforming. In this case any increase in performance would justify the additional cost</p>	Same as change between 2015 IBC-B and 2018 IBC-B	
------------------	-----------------------	--	--	--

RCCIWG – Comment	TAC Action	Commission Action		TAC	Commission
Impactful (Explain) <input type="checkbox"/>	Accommodate Florida Specific Need: YES (Select Criteria) <input type="checkbox"/> NO: <input type="checkbox"/> a. <input type="checkbox"/> b. <input type="checkbox"/> c. <input type="checkbox"/> d. <input type="checkbox"/> e. <input type="checkbox"/> f. <input type="checkbox"/> Others (Explain): <input type="text"/>	Accommodate Florida Specific Need: YES (Select Criteria) <input type="checkbox"/> NO: <input type="checkbox"/> a. <input type="checkbox"/> b. <input type="checkbox"/> c. <input type="checkbox"/> d. <input type="checkbox"/> e. <input type="checkbox"/> f. <input type="checkbox"/> Others (Explain): <input type="text"/>	<input type="checkbox"/> No Action Needed <input type="checkbox"/> Overlapping provisions	<input type="checkbox"/> <input type="checkbox"/>	<input type="checkbox"/> <input type="checkbox"/>

S300-16, Part II	R702.3.1, R702.3.1.1 (New)	<p>Modifies text of Section R702.3.1 “Materials”. Adds new Section R702.3.1.1 “Adhesives”. Adds new standard ASTM D 6464-03a(2009)e1 “Standard Specification for Expandable Foam Adhesives for Fastening Gypsum Wallboard to Wood Framing”. This proposal adds a new referenced standard, ASTM D 6464, which applies to expandable foam adhesives used with gypsum products. The code today refers only to ASTM C 557 for adhesives used with gypsum board, but not all adhesives are included in the scope of ASTM C 557. Additionally, the proposal adds a pointer to Table R702.3.5 or requires approved fastening methods for gypsum products using adhesives. The code change was further modified by the Committee. The modification corrects the reference standard number. With the modification this is a good code change that</p>	Same as change between 2015 IRC and 2018 IRC	
------------------	----------------------------------	--	--	--

Rule 61G20-2.002 2. Technical amendments needed to accommodate the specific needs of this state include but are not limited to amendments to the Florida Building Code that provide for the following: a. Establish minimum life safety construction requirements to protect buildings and their occupants from fire, wind, flood, and storm surge using the latest technical research and engineering standards for buildings and materials products. b. Provide for flood protection provisions that are consistent with the latest flood protection requirements of the National Flood Insurance Program. c. Maintain eligibility for federal funding and discounts from the National Flood Insurance Program, the Federal Emergency Management Agency, and the United States Department of Housing and Urban Development. d. Provide for energy efficiency standards for buildings that meet or exceed the national energy standards as mandated by Title III of the Energy Conservation and Protection Act. e. Maintain coordination with the Florida Fire Prevention Code. f. Provide for the latest industry standards and design

		add a new standard for expandable foam adhesive.		
		<p>Cost Impact: Will not increase the cost of construction. The proposal increases product selection options, but contains no mandatory requirements.</p>		

RCCIWG – Comment	TAC Action	Commission Action	TAC	Commission
Impactful (Explain) <input type="checkbox"/>	Accommodate Florida Specific Need: YES (Select Criteria) <input type="checkbox"/> NO: <input type="checkbox"/> a. <input type="checkbox"/> b. <input type="checkbox"/> c. <input type="checkbox"/> d. <input type="checkbox"/> e. <input type="checkbox"/> f. <input type="checkbox"/> Others (Explain): _____	Accommodate Florida Specific Need: YES (Select Criteria) <input type="checkbox"/> NO: <input type="checkbox"/> a. <input type="checkbox"/> b. <input type="checkbox"/> c. <input type="checkbox"/> d. <input type="checkbox"/> e. <input type="checkbox"/> f. <input type="checkbox"/> Others (Explain): _____	<input type="checkbox"/> No Action Needed <input type="checkbox"/> Overlapping provisions	<input type="checkbox"/> <input type="checkbox"/>

RB218-16	R602.3(6) (New), R602.3.1	Modifies text of Section R602.3.1 “Stud size, height and spacing”. Adds Table R602.3(6) “ALTERNATE WOOD BEARING WALL STUD SIZE, HEIGHT AND SPACING.” The purpose of this code change is to introduce a new table for load-bearing studs over 10 feet in height but not exceeding 12 feet in height Cost Impact: Will not increase the cost of construction. The code change will actually save builders the cost of hiring an engineer to design the portion of the building falling outside the limits of Table R602.3(5) or Exception #2 of Section R602.3.1. The minimum cost to retain an engineer to design the limited area of tall studs is estimated to be \$400 to \$800. The code change will also allow 2x4 studs to be used in cases where 2x6 studs would have been needed previously, for a modest savings in material costs (about \$3-4 per stud).	Same as change between 2015 IRC-B and 2018 IRC-B	No action needed As per R301.2.1.1 of the 2017 FRC, these sections are part of those prescriptive provisions that are not applicable to Florida.
----------	---------------------------	---	--	--

RCCIWG – Comment	TAC Action	Commission Action	TAC	Commission
Impactful (Explain) <input type="checkbox"/>	Accommodate Florida Specific Need: YES (Select Criteria) <input type="checkbox"/> NO: <input type="checkbox"/> a. <input type="checkbox"/> b. <input type="checkbox"/> c. <input type="checkbox"/> d. <input type="checkbox"/> e. <input type="checkbox"/> f. <input type="checkbox"/> Others (Explain): _____	Accommodate Florida Specific Need: YES (Select Criteria) <input type="checkbox"/> NO: <input type="checkbox"/> a. <input type="checkbox"/> b. <input type="checkbox"/> c. <input type="checkbox"/> d. <input type="checkbox"/> e. <input type="checkbox"/> f. <input type="checkbox"/> Others (Explain): _____	<input type="checkbox"/> No Action Needed <input type="checkbox"/> Overlapping provisions	<input type="checkbox"/> <input type="checkbox"/>

Rule 61G20-2.002 2. Technical amendments needed to accommodate the specific needs of this state include but are not limited to amendments to the Florida Building Code that provide for the following:

a. Establish minimum life safety construction requirements to protect buildings and their occupants from fire, wind, flood, and storm surge using the latest technical research and engineering standards for buildings and materials products. b. Provide for flood protection provisions that are consistent with the latest flood protection requirements of the National Flood Insurance Program. c. Maintain eligibility for federal funding and discounts from the National Flood Insurance Program, the Federal Emergency Management Agency, and the United States Department of Housing and Urban Development. d. Provide for energy efficiency standards for buildings that meet or exceed the national energy standards as mandated by Title III of the Energy Conservation and Protection Act. e. Maintain coordination with the Florida Fire Prevention Code. f. Provide for the latest industry standards and design

<p>RB219-16</p>	<p>R602.10.3, R602.3</p>	<p>Modifies text of Table R602.3(1) "FASTENING SCHEDULE", Table R602.10.3 (4) "SEISMIC ADJUSTMENT FACTORS TO THE REQUIRED LENGTH OF WALL BRACING". Revises length of the 10d Common nail, changes to top plate spice nailing. Added bridging to joists. Change to add 7/16" crown.</p> <p>Cost Impact: Will not increase the cost of construction. Because these are mostly editorial corrections and correlations, it is not anticipated that the cost of construction will increase. For rows where the nailing changes slightly, current alternatives are also retained.</p>	<p>Same as change between 2015 IRC-B and 2018 IRC-B</p>	<p>No action needed</p> <p>As per R301.2.1.1 of the 2017 FRC, these sections are part of those prescriptive provisions that are not applicable to Florida.</p>									
<p>RCCIWG – Comment</p> <p>Impactful (Explain) <input type="checkbox"/></p>		<p>TAC Action</p> <p>Accommodate Florida Specific Need: YES (Select Criteria) <input type="checkbox"/> NO: <input type="checkbox"/> a. <input type="checkbox"/> b. <input type="checkbox"/> c. <input type="checkbox"/> d. <input type="checkbox"/> e. <input type="checkbox"/> f. <input type="checkbox"/> Others (Explain): <input type="text"/></p>	<p>Commission Action</p> <p>Accommodate Florida Specific Need: YES (Select Criteria) <input type="checkbox"/> NO: <input type="checkbox"/> a. <input type="checkbox"/> b. <input type="checkbox"/> c. <input type="checkbox"/> d. <input type="checkbox"/> e. <input type="checkbox"/> f. <input type="checkbox"/> Others (Explain): <input type="text"/></p>	<table border="1"> <thead> <tr> <th></th> <th>TAC</th> <th>Commission</th> </tr> </thead> <tbody> <tr> <td><input type="checkbox"/> No Action Needed</td> <td><input type="checkbox"/></td> <td><input type="checkbox"/></td> </tr> <tr> <td><input type="checkbox"/> Overlapping provisions</td> <td><input type="checkbox"/></td> <td><input type="checkbox"/></td> </tr> </tbody> </table>		TAC	Commission	<input type="checkbox"/> No Action Needed	<input type="checkbox"/>	<input type="checkbox"/>	<input type="checkbox"/> Overlapping provisions	<input type="checkbox"/>	<input type="checkbox"/>
	TAC	Commission											
<input type="checkbox"/> No Action Needed	<input type="checkbox"/>	<input type="checkbox"/>											
<input type="checkbox"/> Overlapping provisions	<input type="checkbox"/>	<input type="checkbox"/>											
<p>R220-16</p>	<p>R602.3</p>	<p>Modifies text of Table R602.3(1) This change adds a new standardized roof sheathing ring shank (RSRS) nail for roof sheathing applications.</p> <p>Cost Impact: Will not increase the cost of construction. An alternative nail is being added only, so there is no increase in cost since the current nailing alternatives may still be used.</p>	<p>Same as change between 2015 IRC-B and 2018 IRC-B</p>	<p>No action needed</p> <p>As per R301.2.1.1 of the 2017 FRC, this section is part of those prescriptive provisions that are not applicable to Florida.</p>									
<p>RCCIWG – Comment</p> <p>Impactful (Explain) <input type="checkbox"/></p>		<p>TAC Action</p> <p>Accommodate Florida Specific Need: YES (Select Criteria) <input type="checkbox"/> NO: <input type="checkbox"/> a. <input type="checkbox"/> b. <input type="checkbox"/> c. <input type="checkbox"/> d. <input type="checkbox"/> e. <input type="checkbox"/> f. <input type="checkbox"/> Others (Explain): <input type="text"/></p>	<p>Commission Action</p> <p>Accommodate Florida Specific Need: YES (Select Criteria) <input type="checkbox"/> NO: <input type="checkbox"/> a. <input type="checkbox"/> b. <input type="checkbox"/> c. <input type="checkbox"/> d. <input type="checkbox"/> e. <input type="checkbox"/> f. <input type="checkbox"/> Others (Explain): <input type="text"/></p>	<table border="1"> <thead> <tr> <th></th> <th>TAC</th> <th>Commission</th> </tr> </thead> <tbody> <tr> <td><input type="checkbox"/> No Action Needed</td> <td><input type="checkbox"/></td> <td><input type="checkbox"/></td> </tr> <tr> <td><input type="checkbox"/> Overlapping provisions</td> <td><input type="checkbox"/></td> <td><input type="checkbox"/></td> </tr> </tbody> </table>		TAC	Commission	<input type="checkbox"/> No Action Needed	<input type="checkbox"/>	<input type="checkbox"/>	<input type="checkbox"/> Overlapping provisions	<input type="checkbox"/>	<input type="checkbox"/>
	TAC	Commission											
<input type="checkbox"/> No Action Needed	<input type="checkbox"/>	<input type="checkbox"/>											
<input type="checkbox"/> Overlapping provisions	<input type="checkbox"/>	<input type="checkbox"/>											
<p>RB221-16</p>	<p>R602.3, R803.2.3</p>	<p>Modifies text of Table R602.3(1) "Fastening Schedule" and R803.2.3 "Installation". Nailing requirements for common species of roof framing with specific gravities of 0.42 or greater (e.g. SPF, Hem-Fir) were analyzed and it was found that the nail spacing requirements in footnote "f" needed to be</p>	<p>Same as change between 2015 IRC-B and 2018 IRC-B</p>	<p>No action needed</p> <p>As per R301.2.1.1 of the 2017 FRC, these sections are part of those prescriptive provisions</p>									

Rule 61G20-2.002 2. Technical amendments needed to accommodate the specific needs of this state include but are not limited to amendments to the Florida Building Code that provide for the following: a. Establish minimum life safety construction requirements to protect buildings and their occupants from fire, wind, flood, and storm surge using the latest technical research and engineering standards for buildings and materials products. b. Provide for flood protection provisions that are consistent with the latest flood protection requirements of the National Flood Insurance Program. c. Maintain eligibility for federal funding and discounts from the National Flood Insurance Program, the Federal Emergency Management Agency, and the United States Department of Housing and Urban Development. d. Provide for energy efficiency standards for buildings that meet or exceed the national energy standards as mandated by Title III of the Energy Conservation and Protection Act. e. Maintain coordination with the Florida Fire Prevention Code. f. Provide for the latest industry standards and design

		<p>slightly modified to clarify that nail spacing for all sheathing to framing attached to intermediate supports within 48" of roof end zones, eaves, and ridges must be reduced, not just at the gable end roof framing. A sentence was also added to R803.2.3 to clarify the appropriate limit on the distance unsupported sheathing can cantilever past the gable end roof framing</p> <p>Cost Impact: Will not increase the cost of construction. The change to footnote "f" is a clarification of the current footnote "f" intent. The 9" limit on gable overhang is not really an increase in requirement, but a limitation to allow more efficient nailing patterns.</p>		<p>that are not applicable to Florida.</p>							
<p>RCCIWG – Comment</p> <p>Impactful (Explain) <input type="checkbox"/></p>	<p>TAC Action</p> <p>Accommodate Florida Specific Need:</p> <p>YES (Select Criteria) <input type="checkbox"/> NO: <input type="checkbox"/></p> <p>a. <input type="checkbox"/> b. <input type="checkbox"/> c. <input type="checkbox"/> d. <input type="checkbox"/> e. <input type="checkbox"/> f. <input type="checkbox"/></p> <p>Others (Explain):</p>	<p>Commission Action</p> <p>Accommodate Florida Specific Need:</p> <p>YES (Select Criteria) <input type="checkbox"/> NO: <input type="checkbox"/></p> <p>a. <input type="checkbox"/> b. <input type="checkbox"/> c. <input type="checkbox"/> d. <input type="checkbox"/> e. <input type="checkbox"/> f. <input type="checkbox"/></p> <p>Others (Explain):</p>	<p><input type="checkbox"/> No Action Needed</p> <p><input type="checkbox"/> Overlapping provisions</p>	<table border="1"> <thead> <tr> <th>TAC</th> <th>Commission</th> </tr> </thead> <tbody> <tr> <td><input type="checkbox"/></td> <td><input type="checkbox"/></td> </tr> <tr> <td><input type="checkbox"/></td> <td><input type="checkbox"/></td> </tr> </tbody> </table>	TAC	Commission	<input type="checkbox"/>	<input type="checkbox"/>	<input type="checkbox"/>	<input type="checkbox"/>	
TAC	Commission										
<input type="checkbox"/>	<input type="checkbox"/>										
<input type="checkbox"/>	<input type="checkbox"/>										
<p>RB226-16</p>	<p>R602.7, R602.7(2) (New)</p>	<p>Deletes table R602.7. Adds Table R602.7(2) "GIRDER SPANS AND HEADER SPANS FOR INTERIOR BEARING WALLS." Proposal to update of Table R602.7(2). to address use of Southern Pine No. 2 in lieu of Southern Pine No. 1. Added Footnote "e" to clarify that header spans are based on laterally braced assumption such as when the header is raised.</p> <p>Cost Impact: Will increase the cost of construction. Increased cost may be associated with reduced spans that result from the not laterally braced condition and application of footnote e. Due to smaller building width column (12'), permissible use of Southern Pine No. 2, and the laterally braced assumption for tabulated spans, there are also cases where this change will not increase the cost of construction and may reduce cost of construction.</p>	<p>Same as change between 2015 IRC-B and 2018 IRC-B</p>	<p>No action needed</p> <p>As per R301.2.1.1 of the 2017 FRC, these sections are part of those prescriptive provisions that are not applicable to Florida.</p>							

Rule 61G20-2.002 2. Technical amendments needed to accommodate the specific needs of this state include but are not limited to amendments to the Florida Building Code that provide for the following: a. Establish minimum life safety construction requirements to protect buildings and their occupants from fire, wind, flood, and storm surge using the latest technical research and engineering standards for buildings and materials products. b. Provide for flood protection provisions that are consistent with the latest flood protection requirements of the National Flood Insurance Program. c. Maintain eligibility for federal funding and discounts from the National Flood Insurance Program, the Federal Emergency Management Agency, and the United States Department of Housing and Urban Development. d. Provide for energy efficiency standards for buildings that meet or exceed the national energy standards as mandated by Title III of the Energy Conservation and Protection Act. e. Maintain coordination with the Florida Fire Prevention Code. f. Provide for the latest industry standards and design

RCCIWG – Comment		TAC Action	Commission Action		TAC	Commission
Impactful (Explain) <input type="checkbox"/>		Accommodate Florida Specific Need: YES (Select Criteria) <input type="checkbox"/> NO: <input type="checkbox"/> a. <input type="checkbox"/> b. <input type="checkbox"/> c. <input type="checkbox"/> d. <input type="checkbox"/> e. <input type="checkbox"/> f. <input type="checkbox"/> Others (Explain):	Accommodate Florida Specific Need: YES (Select Criteria) <input type="checkbox"/> NO: <input type="checkbox"/> a. <input type="checkbox"/> b. <input type="checkbox"/> c. <input type="checkbox"/> d. <input type="checkbox"/> e. <input type="checkbox"/> f. <input type="checkbox"/> Others (Explain):	<input type="checkbox"/> No Action Needed	<input type="checkbox"/>	<input type="checkbox"/>
				<input type="checkbox"/> Overlapping provisions	<input type="checkbox"/>	<input type="checkbox"/>
RB227-16	R602.7, R602.7(1) (New)	Deletes Table R602.7. Adds Table R602.7(1) "GIRDER SPANS AND HEADER SPANS FOR EXTERIOR BEARING WALLS". The update of Table R602.7(1) Girder Spans and Header Spans for Exterior Bearing Walls is proposed. Updated spans address use of Southern Pine No. 2 in lieu of Southern Pine No. 1. Footnote "e" is added to clarify that header spans are based on laterally braced assumption such as when the header is raised. Cost Impact: Will increase the cost of construction. Increased cost may be associated with reduced spans that result from the not laterally braced condition and application of footnote f. Due to smaller building width column (12'), permissible use of Southern Pine No. 2, and the laterally braced assumption for tabulated spans, there are also cases where this change will not increase the cost of construction and may reduce cost of construction.	Same as change between 2015 IRC-B and 2018 IRC-B	No action needed As per R301.2.1.1 of the 2017 FRC, these sections are part of those prescriptive provisions that are not applicable to Florida.		
Impactful (Explain) <input type="checkbox"/>		Accommodate Florida Specific Need: YES (Select Criteria) <input type="checkbox"/> NO: <input type="checkbox"/> a. <input type="checkbox"/> b. <input type="checkbox"/> c. <input type="checkbox"/> d. <input type="checkbox"/> e. <input type="checkbox"/> f. <input type="checkbox"/> Others (Explain):	Accommodate Florida Specific Need: YES (Select Criteria) <input type="checkbox"/> NO: <input type="checkbox"/> a. <input type="checkbox"/> b. <input type="checkbox"/> c. <input type="checkbox"/> d. <input type="checkbox"/> e. <input type="checkbox"/> f. <input type="checkbox"/> Others (Explain):	<input type="checkbox"/> No Action Needed	<input type="checkbox"/>	<input type="checkbox"/>
				<input type="checkbox"/> Overlapping provisions	<input type="checkbox"/>	<input type="checkbox"/>
RB228-16	R602.7.2	Modifies Figure R602.7.2 "Rim Board Header Construction". This figure revision clarifies requirements for joist hangers in rim board header applications. Cost Impact: Will not increase the cost of construction. This revision corrects the illustration detail in the previous code edition, and is primarily editorial in nature. Therefore, no	Same as change between 2015 IRC-B and 2018 IRC-B	No action needed As per R301.2.1.1 of the 2017 FRC, this section is part of those prescriptive provisions that are not applicable to		

Rule 61G20-2.002 2. Technical amendments needed to accommodate the specific needs of this state include but are not limited to amendments to the Florida Building Code that provide for the following: a. Establish minimum life safety construction requirements to protect buildings and their occupants from fire, wind, flood, and storm surge using the latest technical research and engineering standards for buildings and materials products. b. Provide for flood protection provisions that are consistent with the latest flood protection requirements of the National Flood Insurance Program. c. Maintain eligibility for federal funding and discounts from the National Flood Insurance Program, the Federal Emergency Management Agency, and the United States Department of Housing and Urban Development. d. Provide for energy efficiency standards for buildings that meet or exceed the national energy standards as mandated by Title III of the Energy Conservation and Protection Act. e. Maintain coordination with the Florida Fire Prevention Code. f. Provide for the latest industry standards and design

		increased cost are associated with this change.		Florida.						
RCCIWG – Comment Impactful (Explain) <input type="checkbox"/>		TAC Action Accommodate Florida Specific Need: YES (Select Criteria) <input type="checkbox"/> NO: <input type="checkbox"/> a. <input type="checkbox"/> b. <input type="checkbox"/> c. <input type="checkbox"/> d. <input type="checkbox"/> e. <input type="checkbox"/> f. <input type="checkbox"/> Others (Explain): _____	Commission Action Accommodate Florida Specific Need: YES (Select Criteria) <input type="checkbox"/> NO: <input type="checkbox"/> a. <input type="checkbox"/> b. <input type="checkbox"/> c. <input type="checkbox"/> d. <input type="checkbox"/> e. <input type="checkbox"/> f. <input type="checkbox"/> Others (Explain): _____	<table border="1"> <tr> <td><input type="checkbox"/> No Action Needed</td> <td>TAC</td> <td>Commission</td> </tr> <tr> <td><input type="checkbox"/> Overlapping provisions</td> <td><input type="checkbox"/></td> <td><input type="checkbox"/></td> </tr> </table>	<input type="checkbox"/> No Action Needed	TAC	Commission	<input type="checkbox"/> Overlapping provisions	<input type="checkbox"/>	<input type="checkbox"/>
<input type="checkbox"/> No Action Needed	TAC	Commission								
<input type="checkbox"/> Overlapping provisions	<input type="checkbox"/>	<input type="checkbox"/>								
RB229-16	R602.7.5	Modifies text of Section R602.7.5 “Supports for headers”. Modifies Table R602.7.5 “MINIMUM NUMBER OF FULL HEIGHT STUDS AT EACH END OF HEADERS IN EXTERIOR WALLS”. change simplifies the full height stud (e.g. king stud) table while also removing conservatism and limited applicability of the 16" maximum stud spacing case. Cost Impact: Will not increase the cost of construction. The proposed table will require less full-height studs than are currently required in some circumstances, and will never require more than are currently required. Therefore the cost of construction will not increase.	Same as change between 2015 IRC-B and 2018 IRC-B	No action needed As per R301.2.1.1 of the 2017 FRC, this section is part of those prescriptive provisions that are not applicable to Florida.						
RCCIWG – Comment Impactful (Explain) <input type="checkbox"/>		TAC Action Accommodate Florida Specific Need: YES (Select Criteria) <input type="checkbox"/> NO: <input type="checkbox"/> a. <input type="checkbox"/> b. <input type="checkbox"/> c. <input type="checkbox"/> d. <input type="checkbox"/> e. <input type="checkbox"/> f. <input type="checkbox"/> Others (Explain): _____	Commission Action Accommodate Florida Specific Need: YES (Select Criteria) <input type="checkbox"/> NO: <input type="checkbox"/> a. <input type="checkbox"/> b. <input type="checkbox"/> c. <input type="checkbox"/> d. <input type="checkbox"/> e. <input type="checkbox"/> f. <input type="checkbox"/> Others (Explain): _____	<table border="1"> <tr> <td><input type="checkbox"/> No Action Needed</td> <td>TAC</td> <td>Commission</td> </tr> <tr> <td><input type="checkbox"/> Overlapping provisions</td> <td><input type="checkbox"/></td> <td><input type="checkbox"/></td> </tr> </table>	<input type="checkbox"/> No Action Needed	TAC	Commission	<input type="checkbox"/> Overlapping provisions	<input type="checkbox"/>	<input type="checkbox"/>
<input type="checkbox"/> No Action Needed	TAC	Commission								
<input type="checkbox"/> Overlapping provisions	<input type="checkbox"/>	<input type="checkbox"/>								
RB230-16	R602, R602.10.10, R602.10.3	Modifies text of table R602.10.3 (2) “WIND ADJUSTMENT FACTORS TO THE REQUIRED LENGTH OF WALL BRACING”. Table R602.10.3 (4) “SEISMIC ADJUSTMENT FACTORS TO THE REQUIRED LENGTH OF WALL BRACING”. Modifies Section R602.10.4.4 “Panel joints”. This code change proposal is intended to move requirements for construction of braced wall panels in R602.10.10 and move it to the section on construction methods for braced wall panels in R602.10.4, and move an existing bracing amount correction from R602.10.10 (exception #3) into the Adjustment	Same as change between 2015 IRC-B and 2018 IRC-B	No action needed As per R301.2.1.1 of the 2017 FRC, these sections are part of those prescriptive provisions that are not applicable to Florida.						

Rule 61G20-2.002 2. Technical amendments needed to accommodate the specific needs of this state include but are not limited to amendments to the Florida Building Code that provide for the following: a. Establish minimum life safety construction requirements to protect buildings and their occupants from fire, wind, flood, and storm surge using the latest technical research and engineering standards for buildings and materials products. b. Provide for flood protection provisions that are consistent with the latest flood protection requirements of the National Flood Insurance Program. c. Maintain eligibility for federal funding and discounts from the National Flood Insurance Program, the Federal Emergency Management Agency, and the United States Department of Housing and Urban Development. d. Provide for energy efficiency standards for buildings that meet or exceed the national energy standards as mandated by Title III of the Energy Conservation and Protection Act. e. Maintain coordination with the Florida Fire Prevention Code. f. Provide for the latest industry standards and design

		<p>Factor Tables, R602.10.3(2) for wind and R602.10.3(4) for seismic.</p> <p>Cost Impact: Will not increase the cost of construction. This change should not increase the cost of construction. Under the 2015 IRC, it is possible that if the bracing amount is doubled, then blocking could be omitted for SFB, vertical GB, or HPS. This option will not be available if this proposal is approved. But the cost of the blocking is far less than the cost of doubling the bracing amount so there should be no cost increase.</p>											
<p>RCCIWG – Comment</p> <p>Impactful (Explain) <input type="checkbox"/></p>		<p>TAC Action</p> <p>Accommodate Florida Specific Need: YES (Select Criteria) <input type="checkbox"/> NO: <input type="checkbox"/></p> <p>a. <input type="checkbox"/> b. <input type="checkbox"/> c. <input type="checkbox"/> d. <input type="checkbox"/> e. <input type="checkbox"/> f. <input type="checkbox"/></p> <p>Others (Explain):</p>	<p>Commission Action</p> <p>Accommodate Florida Specific Need: YES (Select Criteria) <input type="checkbox"/> NO: <input type="checkbox"/></p> <p>a. <input type="checkbox"/> b. <input type="checkbox"/> c. <input type="checkbox"/> d. <input type="checkbox"/> e. <input type="checkbox"/> f. <input type="checkbox"/></p> <p>Others (Explain):</p>	<table border="1"> <thead> <tr> <th></th> <th>TAC</th> <th>Commission</th> </tr> </thead> <tbody> <tr> <td><input type="checkbox"/> No Action Needed</td> <td><input type="checkbox"/></td> <td><input type="checkbox"/></td> </tr> <tr> <td><input type="checkbox"/> Overlapping provisions</td> <td><input type="checkbox"/></td> <td><input type="checkbox"/></td> </tr> </tbody> </table>		TAC	Commission	<input type="checkbox"/> No Action Needed	<input type="checkbox"/>	<input type="checkbox"/>	<input type="checkbox"/> Overlapping provisions	<input type="checkbox"/>	<input type="checkbox"/>
	TAC	Commission											
<input type="checkbox"/> No Action Needed	<input type="checkbox"/>	<input type="checkbox"/>											
<input type="checkbox"/> Overlapping provisions	<input type="checkbox"/>	<input type="checkbox"/>											
RB231-16	R602, R602.10.3	<p>Modifies text of Table R602.10.3(2) “WIND ADJUSTMENT FACTORS TO THE REQUIRED LENGTH OF WALL BRACING”. The added footnote clarifies how to apply the adjustment factor for Exposure Category when there are multiple categories on the site.</p> <p>Cost Impact: Not listed.</p>	Same as change between 2015 IRC-B and 2018 IRC-B	<p>No action needed</p> <p>As per R301.2.1.1 of the 2017 FRC, this section is part of those prescriptive provisions that are not applicable to Florida.</p>									
<p>RCCIWG – Comment</p> <p>Impactful (Explain) <input type="checkbox"/></p>		<p>TAC Action</p> <p>Accommodate Florida Specific Need: YES (Select Criteria) <input type="checkbox"/> NO: <input type="checkbox"/></p> <p>a. <input type="checkbox"/> b. <input type="checkbox"/> c. <input type="checkbox"/> d. <input type="checkbox"/> e. <input type="checkbox"/> f. <input type="checkbox"/></p> <p>Others (Explain):</p>	<p>Commission Action</p> <p>Accommodate Florida Specific Need: YES (Select Criteria) <input type="checkbox"/> NO: <input type="checkbox"/></p> <p>a. <input type="checkbox"/> b. <input type="checkbox"/> c. <input type="checkbox"/> d. <input type="checkbox"/> e. <input type="checkbox"/> f. <input type="checkbox"/></p> <p>Others (Explain):</p>	<table border="1"> <thead> <tr> <th></th> <th>TAC</th> <th>Commission</th> </tr> </thead> <tbody> <tr> <td><input type="checkbox"/> No Action Needed</td> <td><input type="checkbox"/></td> <td><input type="checkbox"/></td> </tr> <tr> <td><input type="checkbox"/> Overlapping provisions</td> <td><input type="checkbox"/></td> <td><input type="checkbox"/></td> </tr> </tbody> </table>		TAC	Commission	<input type="checkbox"/> No Action Needed	<input type="checkbox"/>	<input type="checkbox"/>	<input type="checkbox"/> Overlapping provisions	<input type="checkbox"/>	<input type="checkbox"/>
	TAC	Commission											
<input type="checkbox"/> No Action Needed	<input type="checkbox"/>	<input type="checkbox"/>											
<input type="checkbox"/> Overlapping provisions	<input type="checkbox"/>	<input type="checkbox"/>											
RB233-16	R602.10.3	<p>Modifies text of table R602.10.3 (1) “BRACING REQUIREMENTS BASED ON WIND SPEED”. The callout for Footnote (c) was inadvertently left off of the table. This proposal places it in the table in the appropriate location.</p> <p>Cost Impact: Will not increase the cost of construction.</p>	Same as change between 2015 IRC-B and 2018 IRC-B	<p>No action needed</p> <p>As per R301.2.1.1 of the 2017 FRC, this section is part of those prescriptive provisions</p>									

Rule 61G20-2.002 2. Technical amendments needed to accommodate the specific needs of this state include but are not limited to amendments to the Florida Building Code that provide for the following: a. Establish minimum life safety construction requirements to protect buildings and their occupants from fire, wind, flood, and storm surge using the latest technical research and engineering standards for buildings and materials products. b. Provide for flood protection provisions that are consistent with the latest flood protection requirements of the National Flood Insurance Program. c. Maintain eligibility for federal funding and discounts from the National Flood Insurance Program, the Federal Emergency Management Agency, and the United States Department of Housing and Urban Development. d. Provide for energy efficiency standards for buildings that meet or exceed the national energy standards as mandated by Title III of the Energy Conservation and Protection Act. e. Maintain coordination with the Florida Fire Prevention Code. f. Provide for the latest industry standards and design

						that are not applicable to Florida.										
RCCIWG – Comment Impactful (Explain) <input type="checkbox"/>		TAC Action Accommodate Florida Specific Need: YES (Select Criteria) <input type="checkbox"/> NO: <input type="checkbox"/> a. <input type="checkbox"/> b. <input type="checkbox"/> c. <input type="checkbox"/> d. <input type="checkbox"/> e. <input type="checkbox"/> f. <input type="checkbox"/> Others (Explain): _____		Commission Action Accommodate Florida Specific Need: YES (Select Criteria) <input type="checkbox"/> NO: <input type="checkbox"/> a. <input type="checkbox"/> b. <input type="checkbox"/> c. <input type="checkbox"/> d. <input type="checkbox"/> e. <input type="checkbox"/> f. <input type="checkbox"/> Others (Explain): _____		<table border="1"> <tr> <td></td> <td>TAC</td> <td>Commission</td> </tr> <tr> <td><input type="checkbox"/> No Action Needed</td> <td><input type="checkbox"/></td> <td><input type="checkbox"/></td> </tr> <tr> <td><input type="checkbox"/> Overlapping provisions</td> <td><input type="checkbox"/></td> <td><input type="checkbox"/></td> </tr> </table>			TAC	Commission	<input type="checkbox"/> No Action Needed	<input type="checkbox"/>	<input type="checkbox"/>	<input type="checkbox"/> Overlapping provisions	<input type="checkbox"/>	<input type="checkbox"/>
	TAC	Commission														
<input type="checkbox"/> No Action Needed	<input type="checkbox"/>	<input type="checkbox"/>														
<input type="checkbox"/> Overlapping provisions	<input type="checkbox"/>	<input type="checkbox"/>														
RB234-16	R602.10.3	Modifies text of table “R602.10.3 (2) WIND ADJUSTMENT FACTORS TO THE REQUIRED LENGTH OF WALL BRACING”. The proposed change does three things. It first makes the adjustment based on story height to put it in line with the seismic adjustment table as well as Section R301.3. Secondly, it limits the story height to 11'-7" per Section R301.3 and the new corresponding adjustment factor was interpolated based on the existing values for the adjustment factors for 11 and 12 feet. The third proposed change is to format the "ADJUSTMENT BASED ON" cell. Cost Impact: Will not increase the cost of construction.		Same as change between 2015 IRC-B and 2018 IRC-B		No action needed As per R301.2.1.1 of the 2017 FRC, this section is part of those prescriptive provisions that are not applicable to Florida.										
RCCIWG – Comment Impactful (Explain) <input type="checkbox"/>		TAC Action Accommodate Florida Specific Need: YES (Select Criteria) <input type="checkbox"/> NO: <input type="checkbox"/> a. <input type="checkbox"/> b. <input type="checkbox"/> c. <input type="checkbox"/> d. <input type="checkbox"/> e. <input type="checkbox"/> f. <input type="checkbox"/> Others (Explain): _____		Commission Action Accommodate Florida Specific Need: YES (Select Criteria) <input type="checkbox"/> NO: <input type="checkbox"/> a. <input type="checkbox"/> b. <input type="checkbox"/> c. <input type="checkbox"/> d. <input type="checkbox"/> e. <input type="checkbox"/> f. <input type="checkbox"/> Others (Explain): _____		<table border="1"> <tr> <td></td> <td>TAC</td> <td>Commission</td> </tr> <tr> <td><input type="checkbox"/> No Action Needed</td> <td><input type="checkbox"/></td> <td><input type="checkbox"/></td> </tr> <tr> <td><input type="checkbox"/> Overlapping provisions</td> <td><input type="checkbox"/></td> <td><input type="checkbox"/></td> </tr> </table>			TAC	Commission	<input type="checkbox"/> No Action Needed	<input type="checkbox"/>	<input type="checkbox"/>	<input type="checkbox"/> Overlapping provisions	<input type="checkbox"/>	<input type="checkbox"/>
	TAC	Commission														
<input type="checkbox"/> No Action Needed	<input type="checkbox"/>	<input type="checkbox"/>														
<input type="checkbox"/> Overlapping provisions	<input type="checkbox"/>	<input type="checkbox"/>														
RB235-16	R602.10.3, R602.10.4.1	Modifies text of table R602.10.3 (3) “BRACING REQUIREMENTS BASED ON SEISMIC DESIGN CATEGORY”. Modifies text of Section R602.10.4.1 “Mixing methods”. Modification to the code by listing all the applicable bracing methods in the column heading for the seismic bracing length table, giving the user guidance on when all the methods can be combined, and adding the correct method for determining the length of bracing when certain methods are combined.		Same as change between 2015 IRC-B and 2018 IRC-B		No action needed As per R301.2.1.1 of the 2017 FRC, these sections are part of those prescriptive provisions that are not applicable to Florida. Also, they are seismic design provisions that are not applicable to Florida.										

Rule 61G20-2.002 2. Technical amendments needed to accommodate the specific needs of this state include but are not limited to amendments to the Florida Building Code that provide for the following: a. Establish minimum life safety construction requirements to protect buildings and their occupants from fire, wind, flood, and storm surge using the latest technical research and engineering standards for buildings and materials products. b. Provide for flood protection provisions that are consistent with the latest flood protection requirements of the National Flood Insurance Program. c. Maintain eligibility for federal funding and discounts from the National Flood Insurance Program, the Federal Emergency Management Agency, and the United States Department of Housing and Urban Development. d. Provide for energy efficiency standards for buildings that meet or exceed the national energy standards as mandated by Title III of the Energy Conservation and Protection Act. e. Maintain coordination with the Florida Fire Prevention Code. f. Provide for the latest industry standards and design

		Cost Impact: Will not increase the cost of construction.									
RCCIWG – Comment		TAC Action		Commission Action							
Impactful (Explain) <input type="checkbox"/>		Accommodate Florida Specific Need: YES (Select Criteria) <input type="checkbox"/> NO: <input type="checkbox"/> a. <input type="checkbox"/> b. <input type="checkbox"/> c. <input type="checkbox"/> d. <input type="checkbox"/> e. <input type="checkbox"/> f. <input type="checkbox"/> Others (Explain):		Accommodate Florida Specific Need: YES (Select Criteria) <input type="checkbox"/> NO: <input type="checkbox"/> a. <input type="checkbox"/> b. <input type="checkbox"/> c. <input type="checkbox"/> d. <input type="checkbox"/> e. <input type="checkbox"/> f. <input type="checkbox"/> Others (Explain):							
				<table border="1"> <tr> <td><input type="checkbox"/> No Action Needed</td> <td>TAC <input type="checkbox"/></td> <td>Commission <input type="checkbox"/></td> </tr> <tr> <td><input type="checkbox"/> Overlapping provisions</td> <td><input type="checkbox"/></td> <td><input type="checkbox"/></td> </tr> </table>		<input type="checkbox"/> No Action Needed	TAC <input type="checkbox"/>	Commission <input type="checkbox"/>	<input type="checkbox"/> Overlapping provisions	<input type="checkbox"/>	<input type="checkbox"/>
<input type="checkbox"/> No Action Needed	TAC <input type="checkbox"/>	Commission <input type="checkbox"/>									
<input type="checkbox"/> Overlapping provisions	<input type="checkbox"/>	<input type="checkbox"/>									
RB237-16	R602.10.3	Modifies text of table R602.10.3 (4) “SEISMIC ADJUSTMENT FACTORS TO THE REQUIRED LENGTH OF WALL BRACING”. This proposal will correct the error resulting from the wording change at last cycle and bring the provisions back in line with the 2012 and earlier IRCs Cost Impact: Will not increase the cost of construction.	Same as change between 2015 IRC-B and 2018 IRC-B	No action needed As per R301.2.1.1 of the 2017 FRC, this section is part of those prescriptive provisions that are not applicable to Florida.							
RCCIWG – Comment		TAC Action		Commission Action							
Impactful (Explain) <input type="checkbox"/>		Accommodate Florida Specific Need: YES (Select Criteria) <input type="checkbox"/> NO: <input type="checkbox"/> a. <input type="checkbox"/> b. <input type="checkbox"/> c. <input type="checkbox"/> d. <input type="checkbox"/> e. <input type="checkbox"/> f. <input type="checkbox"/> Others (Explain):		Accommodate Florida Specific Need: YES (Select Criteria) <input type="checkbox"/> NO: <input type="checkbox"/> a. <input type="checkbox"/> b. <input type="checkbox"/> c. <input type="checkbox"/> d. <input type="checkbox"/> e. <input type="checkbox"/> f. <input type="checkbox"/> Others (Explain):							
				<table border="1"> <tr> <td><input type="checkbox"/> No Action Needed</td> <td>TAC <input type="checkbox"/></td> <td>Commission <input type="checkbox"/></td> </tr> <tr> <td><input type="checkbox"/> Overlapping provisions</td> <td><input type="checkbox"/></td> <td><input type="checkbox"/></td> </tr> </table>		<input type="checkbox"/> No Action Needed	TAC <input type="checkbox"/>	Commission <input type="checkbox"/>	<input type="checkbox"/> Overlapping provisions	<input type="checkbox"/>	<input type="checkbox"/>
<input type="checkbox"/> No Action Needed	TAC <input type="checkbox"/>	Commission <input type="checkbox"/>									
<input type="checkbox"/> Overlapping provisions	<input type="checkbox"/>	<input type="checkbox"/>									
RB239-16	R602.10.3, R602.10.6.5	Modifies text of table R602.10.3 (4) “SEISMIC ADJUSTMENT FACTORS TO THE REQUIRED LENGTH OF WALL BRACING”. Modifies text of R602.10.6.5 “Wall bracing for dwellings with stone and masonry veneer in Seismic Design Categories D0, D1 and D2”. The intent of this code change is to provide another alternative in which a moderate amount of second story veneer is permitted with a moderate increase in the bracing wall length, while maintaining a similar level of seismic safety. Cost Impact: Will not increase the cost of construction. This proposal will notably reduce the cost of construction by removing the cost of most or all tie-down hardware. For one example dwelling the cost savings is estimated to be approximately \$3,500.00, including \$3,000 for materials and	Same as change between 2015 IRC-B and 2018 IRC-B	No action needed As per R301.2.1.1 of the 2017 FRC, these sections are part of those prescriptive provisions that are not applicable to Florida. Also, they are seismic design provisions that are not applicable to Florida.							

Rule 61G20-2.002 2. Technical amendments needed to accommodate the specific needs of this state include but are not limited to amendments to the Florida Building Code that provide for the following: a. Establish minimum life safety construction requirements to protect buildings and their occupants from fire, wind, flood, and storm surge using the latest technical research and engineering standards for buildings and materials products. b. Provide for flood protection provisions that are consistent with the latest flood protection requirements of the National Flood Insurance Program. c. Maintain eligibility for federal funding and discounts from the National Flood Insurance Program, the Federal Emergency Management Agency, and the United States Department of Housing and Urban Development. d. Provide for energy efficiency standards for buildings that meet or exceed the national energy standards as mandated by Title III of the Energy Conservation and Protection Act. e. Maintain coordination with the Florida Fire Prevention Code. f. Provide for the latest industry standards and design

		labor to install tie-downs, and \$500.00 in design costs.						
RCCIWG – Comment Impactful (Explain) <input type="checkbox"/>		TAC Action Accommodate Florida Specific Need: YES (Select Criteria) <input type="checkbox"/> NO: <input type="checkbox"/> a. <input type="checkbox"/> b. <input type="checkbox"/> c. <input type="checkbox"/> d. <input type="checkbox"/> e. <input type="checkbox"/> f. <input type="checkbox"/> Others (Explain): _____		Commission Action Accommodate Florida Specific Need: YES (Select Criteria) <input type="checkbox"/> NO: <input type="checkbox"/> a. <input type="checkbox"/> b. <input type="checkbox"/> c. <input type="checkbox"/> d. <input type="checkbox"/> e. <input type="checkbox"/> f. <input type="checkbox"/> Others (Explain): _____		<input type="checkbox"/> No Action Needed <input type="checkbox"/> Overlapping provisions	TAC <input type="checkbox"/> <input type="checkbox"/>	Commission <input type="checkbox"/> <input type="checkbox"/>
RB240-16	R602.10.4	Modifies text of table R602.10.4 “BRACING METHODS”. 8d common nails are no longer recommended for use with structural fiberboard sheathing Cost Impact: Will not increase the cost of construction. Other code approved, prescriptive methods are permitted in lieu of the 8d nail size. Therefore there is no cost increase associated with this revision.	Same as change between 2015 IRC-B and 2018 IRC-B	No action needed As per R301.2.1.1 of the 2017 FRC, this section is part of those prescriptive provisions that are not applicable to Florida.				
RCCIWG – Comment Impactful (Explain) <input type="checkbox"/>		TAC Action Accommodate Florida Specific Need: YES (Select Criteria) <input type="checkbox"/> NO: <input type="checkbox"/> a. <input type="checkbox"/> b. <input type="checkbox"/> c. <input type="checkbox"/> d. <input type="checkbox"/> e. <input type="checkbox"/> f. <input type="checkbox"/> Others (Explain): _____		Commission Action Accommodate Florida Specific Need: YES (Select Criteria) <input type="checkbox"/> NO: <input type="checkbox"/> a. <input type="checkbox"/> b. <input type="checkbox"/> c. <input type="checkbox"/> d. <input type="checkbox"/> e. <input type="checkbox"/> f. <input type="checkbox"/> Others (Explain): _____		<input type="checkbox"/> No Action Needed <input type="checkbox"/> Overlapping provisions	TAC <input type="checkbox"/> <input type="checkbox"/>	Commission <input type="checkbox"/> <input type="checkbox"/>
RB241-16	R602.10.5	Modifies text of Section R602.10.5 “MINIMUM LENGTH OF BRACED WALL PANELS”. The proposed table was reorganized to place the portal frame bracing methods at the bottom of the table for clarity. This change proposal is the results of full-scale tests conducted to determine the correct way to measure portal frame height-to-leg-length aspect ratios. Cost Impact: Will not increase the cost of construction. These provisions will not increase the cost of construction. It provides information based on full scale testing that will permit slightly narrower portal frame leg lengths where appropriate based on the aspect ratio of the portal height as opposed to the wall height. The elimination of the conflict with the footnotes and the table discussed above should clarify, make the code easier to	Same as change between 2015 IRC-B and 2018 IRC-B	No action needed As per R301.2.1.1 of the 2017 FRC, this section is part of those prescriptive provisions that are not applicable to Florida.				

Rule 61G20-2.002 2. Technical amendments needed to accommodate the specific needs of this state include but are not limited to amendments to the Florida Building Code that provide for the following: a. Establish minimum life safety construction requirements to protect buildings and their occupants from fire, wind, flood, and storm surge using the latest technical research and engineering standards for buildings and materials products. b. Provide for flood protection provisions that are consistent with the latest flood protection requirements of the National Flood Insurance Program. c. Maintain eligibility for federal funding and discounts from the National Flood Insurance Program, the Federal Emergency Management Agency, and the United States Department of Housing and Urban Development. d. Provide for energy efficiency standards for buildings that meet or exceed the national energy standards as mandated by Title III of the Energy Conservation and Protection Act. e. Maintain coordination with the Florida Fire Prevention Code. f. Provide for the latest industry standards and design

		use and permit narrower panels to count toward bracing.						
RCCIWG – Comment Impactful (Explain) <input type="checkbox"/>		TAC Action Accommodate Florida Specific Need: YES (Select Criteria) <input type="checkbox"/> NO: <input type="checkbox"/> a. <input type="checkbox"/> b. <input type="checkbox"/> c. <input type="checkbox"/> d. <input type="checkbox"/> e. <input type="checkbox"/> f. <input type="checkbox"/> Others (Explain): _____		Commission Action Accommodate Florida Specific Need: YES (Select Criteria) <input type="checkbox"/> NO: <input type="checkbox"/> a. <input type="checkbox"/> b. <input type="checkbox"/> c. <input type="checkbox"/> d. <input type="checkbox"/> e. <input type="checkbox"/> f. <input type="checkbox"/> Others (Explain): _____		<input type="checkbox"/> No Action Needed <input type="checkbox"/> Overlapping provisions	TAC <input type="checkbox"/> <input type="checkbox"/>	Commission <input type="checkbox"/> <input type="checkbox"/>
RB243-16	R602.10.6.2	Modifies text of Figure R602.10.6.2 “METHOD PFH—PORTAL FRAME WITH HOLD-DOWNS”. The required nailing on the 3500 lb strap provides sufficient anchorage for the wood structural panel to framing connection while prevent the potential for splitting of the framing while anchoring the strap. Cost Impact: Will not increase the cost of construction.		Same as change between 2015 IRC-B and 2018 IRC-B		No action needed As per R301.2.1.1 of the 2017 FRC, this section is part of those prescriptive provisions that are not applicable to Florida.		
RCCIWG – Comment Impactful (Explain) <input type="checkbox"/>		TAC Action Accommodate Florida Specific Need: YES (Select Criteria) <input type="checkbox"/> NO: <input type="checkbox"/> a. <input type="checkbox"/> b. <input type="checkbox"/> c. <input type="checkbox"/> d. <input type="checkbox"/> e. <input type="checkbox"/> f. <input type="checkbox"/> Others (Explain): _____		Commission Action Accommodate Florida Specific Need: YES (Select Criteria) <input type="checkbox"/> NO: <input type="checkbox"/> a. <input type="checkbox"/> b. <input type="checkbox"/> c. <input type="checkbox"/> d. <input type="checkbox"/> e. <input type="checkbox"/> f. <input type="checkbox"/> Others (Explain): _____		<input type="checkbox"/> No Action Needed <input type="checkbox"/> Overlapping provisions	TAC <input type="checkbox"/> <input type="checkbox"/>	Commission <input type="checkbox"/> <input type="checkbox"/>
RB244-16	R602.10.6.4	Modifies Figure R602.10.6.4 “METHOD CS-PF—CONTINUOUSLY SHEATHED PORTAL FRAME PANEL CONSTRUCTION”. Changed min wood structural panel sheathing to 3/8”. Modified area to show two rows of nails to match other cut section views. Cost Impact: Will not increase the cost of construction.		Same as change between 2015 IRC-B and 2018 IRC-B		No action needed As per R301.2.1.1 of the 2017 FRC, this section is part of those prescriptive provisions that are not applicable to Florida.		
RCCIWG – Comment Impactful (Explain) <input type="checkbox"/>		TAC Action Accommodate Florida Specific Need: YES (Select Criteria) <input type="checkbox"/> NO: <input type="checkbox"/> a. <input type="checkbox"/> b. <input type="checkbox"/> c. <input type="checkbox"/> d. <input type="checkbox"/> e. <input type="checkbox"/> f. <input type="checkbox"/> Others (Explain): _____		Commission Action Accommodate Florida Specific Need: YES (Select Criteria) <input type="checkbox"/> NO: <input type="checkbox"/> a. <input type="checkbox"/> b. <input type="checkbox"/> c. <input type="checkbox"/> d. <input type="checkbox"/> e. <input type="checkbox"/> f. <input type="checkbox"/> Others (Explain): _____		<input type="checkbox"/> No Action Needed <input type="checkbox"/> Overlapping provisions	TAC <input type="checkbox"/> <input type="checkbox"/>	Commission <input type="checkbox"/> <input type="checkbox"/>

Rule 61G20-2.002 2. Technical amendments needed to accommodate the specific needs of this state include but are not limited to amendments to the Florida Building Code that provide for the following: a. Establish minimum life safety construction requirements to protect buildings and their occupants from fire, wind, flood, and storm surge using the latest technical research and engineering standards for buildings and materials products. b. Provide for flood protection provisions that are consistent with the latest flood protection requirements of the National Flood Insurance Program. c. Maintain eligibility for federal funding and discounts from the National Flood Insurance Program, the Federal Emergency Management Agency, and the United States Department of Housing and Urban Development. d. Provide for energy efficiency standards for buildings that meet or exceed the national energy standards as mandated by Title III of the Energy Conservation and Protection Act. e. Maintain coordination with the Florida Fire Prevention Code. f. Provide for the latest industry standards and design

RB245-16	R602.10.6.4	<p>Modifies text of Figure “R602.10.6.4 METHOD CS-PF— CONTINUOUSLY SHEATHED PORTAL FRAME PANEL CONSTRUCTION”. The proposed code change more clearly states the intent of the language shown in the figure. Reference to Table R602.10.5.</p> <p>Cost Impact: Will not increase the cost of construction.</p>	Same as change between 2015 IRC-B and 2018 IRC-B	<p>No action needed</p> <p>As per R301.2.1.1 of the 2017 FRC, this section is part of those prescriptive provisions that are not applicable to Florida.</p>									
<p>RCCIWG – Comment</p> <p>Impactful (Explain) <input type="checkbox"/></p>		<p>TAC Action</p> <p>Accommodate Florida Specific Need: YES (Select Criteria) <input type="checkbox"/> NO: <input type="checkbox"/></p> <p>a. <input type="checkbox"/> b. <input type="checkbox"/> c. <input type="checkbox"/> d. <input type="checkbox"/> e. <input type="checkbox"/> f. <input type="checkbox"/></p> <p>Others (Explain):</p>	<p>Commission Action</p> <p>Accommodate Florida Specific Need: YES (Select Criteria) <input type="checkbox"/> NO: <input type="checkbox"/></p> <p>a. <input type="checkbox"/> b. <input type="checkbox"/> c. <input type="checkbox"/> d. <input type="checkbox"/> e. <input type="checkbox"/> f. <input type="checkbox"/></p> <p>Others (Explain):</p>	<table border="1"> <thead> <tr> <th></th> <th>TAC</th> <th>Commission</th> </tr> </thead> <tbody> <tr> <td><input type="checkbox"/> No Action Needed</td> <td><input type="checkbox"/></td> <td><input type="checkbox"/></td> </tr> <tr> <td><input type="checkbox"/> Overlapping provisions</td> <td><input type="checkbox"/></td> <td><input type="checkbox"/></td> </tr> </tbody> </table>		TAC	Commission	<input type="checkbox"/> No Action Needed	<input type="checkbox"/>	<input type="checkbox"/>	<input type="checkbox"/> Overlapping provisions	<input type="checkbox"/>	<input type="checkbox"/>
	TAC	Commission											
<input type="checkbox"/> No Action Needed	<input type="checkbox"/>	<input type="checkbox"/>											
<input type="checkbox"/> Overlapping provisions	<input type="checkbox"/>	<input type="checkbox"/>											
RB248-16	<p>R603.1.1, R603.3.1, R603.3.1.1, R603.3.2, R603.3.2.1, R603.3.5, R603.6, R603.7, R603.8, R603.9.2, R603.9.4.1</p>	<p>Modifies text of Section R603.1.1 “Applicability limits”, R603.3.5 “Splicing”, R603.6 “Headers”. Modifies text of Table R603.3.1 “WALL TO FOUNDATION OR FLOOR CONNECTION REQUIREMENTS”, Table R603.3.1.1 (1) “GABLE ENDWALL TO FLOOR CONNECTION REQUIREMENTS”, TABLE R603.3.1.1 (2) “GABLE ENDWALL BOTTOM TRACK TO FOUNDATION CONNECTION REQUIREMENTS”, TABLE R603.3.2 (2) thru (16) “__-FOOT-WIDE BUILDING SUPPORTING ROOF AND CEILING ONLY,” Table R603.3.2.1 (1) “ALL BUILDING WIDTHS GABLE ENDWALLS 8, 9 OR 10 FEET IN HEIGHT”, TABLE R603.3.2.1 (2) “ALL BUILDING WIDTHS GABLE ENDWALLS OVER 10 FEET IN HEIGHT”, TABLE R603.7 (2) “HEADER TO KING STUD CONNECTION REQUIREMENTS”, TABLE R603.8 “HEAD AND SILL TRACK SPAN”, TABLE R603.9.2 (1) “MINIMUM PERCENTAGE OF FULL-HEIGHT STRUCTURAL SHEATHING ON EXTERIOR WALLS”. Adds new standard “AISI S240-15, North American</p>	Same as change between 2015 IRC-B and 2018 IRC-B	<p>No action needed</p> <p>As per R301.2.1.1 of the 2017 FRC, these sections are part of those prescriptive provisions that are not applicable to Florida. In addition, they are seismic design provisions that are not applicable to Florida.</p>									

Rule 61G20-2.002 2. Technical amendments needed to accommodate the specific needs of this state include but are not limited to amendments to the Florida Building Code that provide for the following: a. Establish minimum life safety construction requirements to protect buildings and their occupants from fire, wind, flood, and storm surge using the latest technical research and engineering standards for buildings and materials products. b. Provide for flood protection provisions that are consistent with the latest flood protection requirements of the National Flood Insurance Program. c. Maintain eligibility for federal funding and discounts from the National Flood Insurance Program, the Federal Emergency Management Agency, and the United States Department of Housing and Urban Development. d. Provide for energy efficiency standards for buildings that meet or exceed the national energy standards as mandated by Title III of the Energy Conservation and Protection Act. e. Maintain coordination with the Florida Fire Prevention Code. f. Provide for the latest industry standards and design

		<p>Standard for Cold-Formed Steel Structural Framing (2015)".</p> <p>This proposal is one in a series intended to update the content of the Cold-Formed Steel (CFS) light-framed construction provisions of the IRC. The proposed revisions align the IRC with the provisions of AISI S230-15, Standard for Cold-Formed Steel Framing - Prescriptive Method for One- and Two-Family Dwellings. Also, the applicable design wind speed is changed to less than 140 mph ultimate. The framing tables are revised to reflect the wind load increase and to align with ASCE 7-10. Directional Method.</p> <p>Cost Impact: Will increase the cost of construction. The proposed changes to this section will not increase the cost of construction in general. While the overwhelming majority of the prescribed members have not changed or are reduced in size, there may be conditions for which the minimum member size will increase.</p>			
<p>RCCIWG – Comment</p> <p>Impactful (Explain) <input type="checkbox"/></p>	<p>TAC Action</p> <p>Accommodate Florida Specific Need: YES (Select Criteria) <input type="checkbox"/> NO: <input type="checkbox"/> a. <input type="checkbox"/> b. <input type="checkbox"/> c. <input type="checkbox"/> d. <input type="checkbox"/> e. <input type="checkbox"/> f. <input type="checkbox"/> Others (Explain): <input type="text"/></p>	<p>Commission Action</p> <p>Accommodate Florida Specific Need: YES (Select Criteria) <input type="checkbox"/> NO: <input type="checkbox"/> a. <input type="checkbox"/> b. <input type="checkbox"/> c. <input type="checkbox"/> d. <input type="checkbox"/> e. <input type="checkbox"/> f. <input type="checkbox"/> Others (Explain): <input type="text"/></p>	<p><input type="checkbox"/> No Action Needed</p> <p><input type="checkbox"/> Overlapping provisions</p>	<p>TAC</p> <p><input type="checkbox"/></p> <p><input type="checkbox"/></p>	<p>Commission</p> <p><input type="checkbox"/></p> <p><input type="checkbox"/></p>
<p>RB249-16</p>	<p>R606.1</p>	<p>Modifies text of Section R606.1 "General". Adds new standard "TMS 404-16 – Standard for the Design of Architectural Cast Stone". Added standard TMS 404-16 to R606.1.</p> <p>Cost Impact: Will not increase the cost of construction. The addition of these news standards is an alternative to the existing IRC provisions based on existing industry best practices</p>	<p>Same as change between 2015 IRC-B and 2018 IRC-B</p>		

Rule 61G20-2.002 2. Technical amendments needed to accommodate the specific needs of this state include but are not limited to amendments to the Florida Building Code that provide for the following: a. Establish minimum life safety construction requirements to protect buildings and their occupants from fire, wind, flood, and storm surge using the latest technical research and engineering standards for buildings and materials products. b. Provide for flood protection provisions that are consistent with the latest flood protection requirements of the National Flood Insurance Program. c. Maintain eligibility for federal funding and discounts from the National Flood Insurance Program, the Federal Emergency Management Agency, and the United States Department of Housing and Urban Development. d. Provide for energy efficiency standards for buildings that meet or exceed the national energy standards as mandated by Title III of the Energy Conservation and Protection Act. e. Maintain coordination with the Florida Fire Prevention Code. f. Provide for the latest industry standards and design

RCCIWG – Comment		TAC Action	Commission Action		TAC	Commission
Impactful (Explain) <input type="checkbox"/>		Accommodate Florida Specific Need: YES (Select Criteria) <input type="checkbox"/> NO: <input type="checkbox"/> a. <input type="checkbox"/> b. <input type="checkbox"/> c. <input type="checkbox"/> d. <input type="checkbox"/> e. <input type="checkbox"/> f. <input type="checkbox"/> Others (Explain): <input type="text"/>	Accommodate Florida Specific Need: YES (Select Criteria) <input type="checkbox"/> NO: <input type="checkbox"/> a. <input type="checkbox"/> b. <input type="checkbox"/> c. <input type="checkbox"/> d. <input type="checkbox"/> e. <input type="checkbox"/> f. <input type="checkbox"/> Others (Explain): <input type="text"/>		<input type="checkbox"/> No Action Needed <input type="checkbox"/> Overlapping provisions	
RB254-16	R609.2	Modifies text of Section R609.2 “Performance”. This proposal is intended to clarify that the use of the 0.6 conversion multiplier is allowed with respect to the determination of design wind pressures in accordance with ASCE 7 and testing of the respective assemblies in accordance with Section R609.3 or R609.5 accordingly. The code change was further modified by the Committee. The modification clarifies where the 0.6 multiplier is to be applied. Cost Impact: Will not increase the cost of construction. This is a clarification. No substantive change.		Same as change between 2015 IRC-B and 2018 IRC-B		
Impactful (Explain) <input type="checkbox"/>		Accommodate Florida Specific Need: YES (Select Criteria) <input type="checkbox"/> NO: <input type="checkbox"/> a. <input type="checkbox"/> b. <input type="checkbox"/> c. <input type="checkbox"/> d. <input type="checkbox"/> e. <input type="checkbox"/> f. <input type="checkbox"/> Others (Explain): <input type="text"/>	Accommodate Florida Specific Need: YES (Select Criteria) <input type="checkbox"/> NO: <input type="checkbox"/> a. <input type="checkbox"/> b. <input type="checkbox"/> c. <input type="checkbox"/> d. <input type="checkbox"/> e. <input type="checkbox"/> f. <input type="checkbox"/> Others (Explain): <input type="text"/>		<input type="checkbox"/> No Action Needed <input type="checkbox"/> Overlapping provisions	
RB259-16	R202 (New), R609.6, R609.6.1, R609.6.2 (New)	Adds new definition “Impact Protective System”. Modifies text of Section R609.6 “Wind-borne debris protection”, R609.6.1 “Fenestration testing and labeling”. Adds new standards R609.6.2 “Impact protective systems testing and labeling”. The primary purpose of this code change is to require that impact protective systems (hurricane shutters) have a permanent label that provides a way for building owners, homeowners, and others to be able to determine their performance characteristics after the building has been occupied. Cost Impact: Will increase the cost of construction. Will result in an increase in cost. A consultant representing the industry estimates the cost of providing labels on impact		This change is not similar to that of the FRC. The FRC provides for Florida specific changes to this section	Overlapping provision to be considered during step 2 of the code change process	

Rule 61G20-2.002 2. Technical amendments needed to accommodate the specific needs of this state include but are not limited to amendments to the Florida Building Code that provide for the following: a. Establish minimum life safety construction requirements to protect buildings and their occupants from fire, wind, flood, and storm surge using the latest technical research and engineering standards for buildings and materials products. b. Provide for flood protection provisions that are consistent with the latest flood protection requirements of the National Flood Insurance Program. c. Maintain eligibility for federal funding and discounts from the National Flood Insurance Program, the Federal Emergency Management Agency, and the United States Department of Housing and Urban Development. d. Provide for energy efficiency standards for buildings that meet or exceed the national energy standards as mandated by Title III of the Energy Conservation and Protection Act. e. Maintain coordination with the Florida Fire Prevention Code. f. Provide for the latest industry standards and design

		resistant covering products to be as follows: a). Water Resistant Self-adhering Permanent Labels approximately \$0.15 per label. Such labels would most likely be used on Accordion, Roll, Bahama, and Colonial style shutters. b). Embossed or ink jet labels used on metal and plastic panels would cost approximately \$0.05 per label.									
RCCIWG – Comment Impactful (Explain) <input type="checkbox"/>		TAC Action Accommodate Florida Specific Need: YES (Select Criteria) <input type="checkbox"/> NO: <input type="checkbox"/> a. <input type="checkbox"/> b. <input type="checkbox"/> c. <input type="checkbox"/> d. <input type="checkbox"/> e. <input type="checkbox"/> f. <input type="checkbox"/> Others (Explain): _____	Commission Action Accommodate Florida Specific Need: YES (Select Criteria) <input type="checkbox"/> NO: <input type="checkbox"/> a. <input type="checkbox"/> b. <input type="checkbox"/> c. <input type="checkbox"/> d. <input type="checkbox"/> e. <input type="checkbox"/> f. <input type="checkbox"/> Others (Explain): _____	<input type="checkbox"/> No Action Needed <input type="checkbox"/> Overlapping provisions	<table border="1"> <tr> <th>TAC</th> <th>Commission</th> </tr> <tr> <td><input type="checkbox"/></td> <td><input type="checkbox"/></td> </tr> <tr> <td><input type="checkbox"/></td> <td><input type="checkbox"/></td> </tr> </table>	TAC	Commission	<input type="checkbox"/>	<input type="checkbox"/>	<input type="checkbox"/>	<input type="checkbox"/>
TAC	Commission										
<input type="checkbox"/>	<input type="checkbox"/>										
<input type="checkbox"/>	<input type="checkbox"/>										
RB260-16	R702.2.1	Modifies text of Section R702.2.1 “Gypsum plaster”. Adds new standards “ASTM C 841-03 (Reapproved 2013) Standard Specification for Installation of Interior Lathing and Furring” and “ASTM C 842-05 (Reapproved 2015) Standard Specification for Application of Interior Gypsum Plaster”. Adding ASTM C 841-03 and ASTM C 842-05 to Section R702.2.1 and reference to ASTM C844 added to R702.2.1. Cost Impact: Will not increase the cost of construction. There is no cost of construction significance in this item.	Same as change between 2015 IRC-B and 2018 IRC-B								
RCCIWG – Comment Impactful (Explain) <input type="checkbox"/>		TAC Action Accommodate Florida Specific Need: YES (Select Criteria) <input type="checkbox"/> NO: <input type="checkbox"/> a. <input type="checkbox"/> b. <input type="checkbox"/> c. <input type="checkbox"/> d. <input type="checkbox"/> e. <input type="checkbox"/> f. <input type="checkbox"/> Others (Explain): _____	Commission Action Accommodate Florida Specific Need: YES (Select Criteria) <input type="checkbox"/> NO: <input type="checkbox"/> a. <input type="checkbox"/> b. <input type="checkbox"/> c. <input type="checkbox"/> d. <input type="checkbox"/> e. <input type="checkbox"/> f. <input type="checkbox"/> Others (Explain): _____	<input type="checkbox"/> No Action Needed <input type="checkbox"/> Overlapping provisions	<table border="1"> <tr> <th>TAC</th> <th>Commission</th> </tr> <tr> <td><input type="checkbox"/></td> <td><input type="checkbox"/></td> </tr> <tr> <td><input type="checkbox"/></td> <td><input type="checkbox"/></td> </tr> </table>	TAC	Commission	<input type="checkbox"/>	<input type="checkbox"/>	<input type="checkbox"/>	<input type="checkbox"/>
TAC	Commission										
<input type="checkbox"/>	<input type="checkbox"/>										
<input type="checkbox"/>	<input type="checkbox"/>										
RB261-16	R702.2.2	Modifies text of Section R702.2.2 Cement plaster. Currently there is a misplacement error in the reference standards as listed in the current section. Deletes text of Section as well. Cost Impact: Will not increase the cost of construction. There is no cost of construction significance in this item.	Same as change between 2015 IRC-B and 2018 IRC-B								

Rule 61G20-2.002 2. Technical amendments needed to accommodate the specific needs of this state include but are not limited to amendments to the Florida Building Code that provide for the following: a. Establish minimum life safety construction requirements to protect buildings and their occupants from fire, wind, flood, and storm surge using the latest technical research and engineering standards for buildings and materials products. b. Provide for flood protection provisions that are consistent with the latest flood protection requirements of the National Flood Insurance Program. c. Maintain eligibility for federal funding and discounts from the National Flood Insurance Program, the Federal Emergency Management Agency, and the United States Department of Housing and Urban Development. d. Provide for energy efficiency standards for buildings that meet or exceed the national energy standards as mandated by Title III of the Energy Conservation and Protection Act. e. Maintain coordination with the Florida Fire Prevention Code. f. Provide for the latest industry standards and design

RCCIWG – Comment		TAC Action	Commission Action		TAC	Commission
Impactful (Explain) <input type="checkbox"/>		Accommodate Florida Specific Need: YES (Select Criteria) <input type="checkbox"/> NO: <input type="checkbox"/> a. <input type="checkbox"/> b. <input type="checkbox"/> c. <input type="checkbox"/> d. <input type="checkbox"/> e. <input type="checkbox"/> f. <input type="checkbox"/> Others (Explain): <input type="text"/>	Accommodate Florida Specific Need: YES (Select Criteria) <input type="checkbox"/> NO: <input type="checkbox"/> a. <input type="checkbox"/> b. <input type="checkbox"/> c. <input type="checkbox"/> d. <input type="checkbox"/> e. <input type="checkbox"/> f. <input type="checkbox"/> Others (Explain): <input type="text"/>	<input type="checkbox"/> No Action Needed <input type="checkbox"/> Overlapping provisions	<input type="checkbox"/>	<input type="checkbox"/>
RB264-16	R702.3.1	Modifies text of Section R702.3.1 “Materials”. Adds new standard “ASTM C 1766-13 Standard Specification for Factory-Laminated Gypsum Panel Products”. ASTM C1766 was developed by ASTM subcommittee C11.01, assigned the responsibility for the development and maintenance of test methods and materials for gypsum products. Cost Impact: Will not increase the cost of construction. The proposal adds in a product standard that extends performance requirements for factory-laminated products to meet the current intent of the code. The proposal increases product selection options , but contains no mandatory requirements.		Same as change between 2015 IRC-B and 2018 IRC-B		
Impactful (Explain) <input type="checkbox"/>		Accommodate Florida Specific Need: YES (Select Criteria) <input type="checkbox"/> NO: <input type="checkbox"/> a. <input type="checkbox"/> b. <input type="checkbox"/> c. <input type="checkbox"/> d. <input type="checkbox"/> e. <input type="checkbox"/> f. <input type="checkbox"/> Others (Explain): <input type="text"/>	Accommodate Florida Specific Need: YES (Select Criteria) <input type="checkbox"/> NO: <input type="checkbox"/> a. <input type="checkbox"/> b. <input type="checkbox"/> c. <input type="checkbox"/> d. <input type="checkbox"/> e. <input type="checkbox"/> f. <input type="checkbox"/> Others (Explain): <input type="text"/>	<input type="checkbox"/> No Action Needed <input type="checkbox"/> Overlapping provisions	<input type="checkbox"/>	<input type="checkbox"/>
RB265-16	R702.3.3	Modifies text of Section R702.3.3 Cold-formed steel framing. Adds new standard “AISI S240-15, North American Standard for Cold-Formed Steel Structural Framing (2015)”. The screw penetration test, as referenced to ASTM C645, Section 10, has been incorporated into AISI S220-15, North American Standard for Cold-Formed Steel Framing - Non-Structural Members. Reference to AISI S220 is added to cover those requirements. Cost Impact: Will not increase the cost of construction. This proposal is intended to update the referenced AISI standards and does not affect the intended prescribed construction requirements.		Same as change between 2015 IRC-B and 2018 IRC-B		

Rule 61G20-2.002 2. Technical amendments needed to accommodate the specific needs of this state include but are not limited to amendments to the Florida Building Code that provide for the following: a. Establish minimum life safety construction requirements to protect buildings and their occupants from fire, wind, flood, and storm surge using the latest technical research and engineering standards for buildings and materials products. b. Provide for flood protection provisions that are consistent with the latest flood protection requirements of the National Flood Insurance Program. c. Maintain eligibility for federal funding and discounts from the National Flood Insurance Program, the Federal Emergency Management Agency, and the United States Department of Housing and Urban Development. d. Provide for energy efficiency standards for buildings that meet or exceed the national energy standards as mandated by Title III of the Energy Conservation and Protection Act. e. Maintain coordination with the Florida Fire Prevention Code. f. Provide for the latest industry standards and design

RCCIWG – Comment		TAC Action	Commission Action		TAC	Commission
Impactful (Explain) <input type="checkbox"/>		Accommodate Florida Specific Need: YES (Select Criteria) <input type="checkbox"/> NO: <input type="checkbox"/> a. <input type="checkbox"/> b. <input type="checkbox"/> c. <input type="checkbox"/> d. <input type="checkbox"/> e. <input type="checkbox"/> f. <input type="checkbox"/> Others (Explain): <input type="text"/>	Accommodate Florida Specific Need: YES (Select Criteria) <input type="checkbox"/> NO: <input type="checkbox"/> a. <input type="checkbox"/> b. <input type="checkbox"/> c. <input type="checkbox"/> d. <input type="checkbox"/> e. <input type="checkbox"/> f. <input type="checkbox"/> Others (Explain): <input type="text"/>	<input type="checkbox"/> No Action Needed <input type="checkbox"/> Overlapping provisions	<input type="checkbox"/>	<input type="checkbox"/>
RB276-16	R702.7.3	Modifies text of Section R702.7.3 “Minimum clear airspaces and vented openings for vented cladding”. Adding recognition of polypropylene to R702.7.3. Cost Impact: Will not increase the cost of construction. This change simply identifies another type of vented cladding.		Same as change between 2015 IRC-B and 2018 IRC-B		
Impactful (Explain) <input type="checkbox"/>		Accommodate Florida Specific Need: YES (Select Criteria) <input type="checkbox"/> NO: <input type="checkbox"/> a. <input type="checkbox"/> b. <input type="checkbox"/> c. <input type="checkbox"/> d. <input type="checkbox"/> e. <input type="checkbox"/> f. <input type="checkbox"/> Others (Explain): <input type="text"/>	Accommodate Florida Specific Need: YES (Select Criteria) <input type="checkbox"/> NO: <input type="checkbox"/> a. <input type="checkbox"/> b. <input type="checkbox"/> c. <input type="checkbox"/> d. <input type="checkbox"/> e. <input type="checkbox"/> f. <input type="checkbox"/> Others (Explain): <input type="text"/>	<input type="checkbox"/> No Action Needed <input type="checkbox"/> Overlapping provisions	<input type="checkbox"/>	<input type="checkbox"/>
RB280-16	R703.1.1	Modifies text of Section R703.1.1 “Water resistance”. Replaces references to veneer with “cladding”. Also the last sentence is deleted as it does not belong the section of the code and is addressed in the APA code change proposal on R702.7. Cost Impact: Will not increase the cost of construction. This code change will not increase the cost of construction as it clarifies the intent of the original code provisions.		Same as change between 2015 IRC-B and 2018 IRC-B		
Impactful (Explain) <input type="checkbox"/>		Accommodate Florida Specific Need: YES (Select Criteria) <input type="checkbox"/> NO: <input type="checkbox"/> a. <input type="checkbox"/> b. <input type="checkbox"/> c. <input type="checkbox"/> d. <input type="checkbox"/> e. <input type="checkbox"/> f. <input type="checkbox"/> Others (Explain): <input type="text"/>	Accommodate Florida Specific Need: YES (Select Criteria) <input type="checkbox"/> NO: <input type="checkbox"/> a. <input type="checkbox"/> b. <input type="checkbox"/> c. <input type="checkbox"/> d. <input type="checkbox"/> e. <input type="checkbox"/> f. <input type="checkbox"/> Others (Explain): <input type="text"/>	<input type="checkbox"/> No Action Needed <input type="checkbox"/> Overlapping provisions	<input type="checkbox"/>	<input type="checkbox"/>

Rule 61G20-2.002 2. Technical amendments needed to accommodate the specific needs of this state include but are not limited to amendments to the Florida Building Code that provide for the following: a. Establish minimum life safety construction requirements to protect buildings and their occupants from fire, wind, flood, and storm surge using the latest technical research and engineering standards for buildings and materials products. b. Provide for flood protection provisions that are consistent with the latest flood protection requirements of the National Flood Insurance Program. c. Maintain eligibility for federal funding and discounts from the National Flood Insurance Program, the Federal Emergency Management Agency, and the United States Department of Housing and Urban Development. d. Provide for energy efficiency standards for buildings that meet or exceed the national energy standards as mandated by Title III of the Energy Conservation and Protection Act. e. Maintain coordination with the Florida Fire Prevention Code. f. Provide for the latest industry standards and design

<p>RB282-16</p>	<p>R703.1.2, R703.11.1.4, R703.3, R703.3.1, R703.3.1 (New), R703.3.1.1 (New), R703.3.2</p>	<p>Modifies text of Section R703.1.2 “Wind resistance”, R703.3.1.1 “Wood structural panel soffit”, R703.3.1.2 “Vinyl soffit panels”, R703.3.2 “Wind limitations”. Revises R703.3.1 “Soffit Installation”. Proposal, which was modified by committee, to improve the durability of soffits in high wind regions while allowing continued use of traditional soffit materials in the low wind regions.</p> <p>Cost Impact: <u>Will increase the cost of construction.</u> May result in an increase in the cost of construction for lower wind regions as the IRC doesn't specifically address soffit installation or attachment. However, any initial minimal up front construction costs will result in reduced owner residual risk through improved resilience to high wind loading, reduced wind driven rain associated damages and more than offset costs through mitigating already well documented failure modes and vulnerabilities.</p>	<p>This change is not similar to that of the FRC. The FRC provides for Florida specific changes to this section</p>	<p>Overlapping provision to be considered during step 2 of the code change process</p>									
<p>RCCIWG – Comment</p> <p>Impactful (Explain) <input type="checkbox"/></p>		<p>TAC Action</p> <p>Accommodate Florida Specific Need: YES (Select Criteria) <input type="checkbox"/> NO: <input type="checkbox"/></p> <p>a. <input type="checkbox"/> b. <input type="checkbox"/> c. <input type="checkbox"/> d. <input type="checkbox"/> e. <input type="checkbox"/> f. <input type="checkbox"/></p> <p>Others (Explain):</p>	<p>Commission Action</p> <p>Accommodate Florida Specific Need: YES (Select Criteria) <input type="checkbox"/> NO: <input type="checkbox"/></p> <p>a. <input type="checkbox"/> b. <input type="checkbox"/> c. <input type="checkbox"/> d. <input type="checkbox"/> e. <input type="checkbox"/> f. <input type="checkbox"/></p> <p>Others (Explain):</p>	<table border="1"> <thead> <tr> <th></th> <th>TAC</th> <th>Commission</th> </tr> </thead> <tbody> <tr> <td><input type="checkbox"/> No Action Needed</td> <td><input type="checkbox"/></td> <td><input type="checkbox"/></td> </tr> <tr> <td><input type="checkbox"/> Overlapping provisions</td> <td><input type="checkbox"/></td> <td><input type="checkbox"/></td> </tr> </tbody> </table>		TAC	Commission	<input type="checkbox"/> No Action Needed	<input type="checkbox"/>	<input type="checkbox"/>	<input type="checkbox"/> Overlapping provisions	<input type="checkbox"/>	<input type="checkbox"/>
	TAC	Commission											
<input type="checkbox"/> No Action Needed	<input type="checkbox"/>	<input type="checkbox"/>											
<input type="checkbox"/> Overlapping provisions	<input type="checkbox"/>	<input type="checkbox"/>											
<p>RB283-16</p>	<p>R703.2</p>	<p>Modifies text of Section R703.2 “Water-resistive barrier”. This proposal clarifies requirements for No. 15 asphalt felt and distinguishes requirements for other approved water resistive barriers (WRBs) to improve application and enforceability.</p> <p>Cost Impact: Will not increase the cost of construction. The proposal clarifies requirements and may actually help avoid unintended cost impacts or material choice limitations</p>	<p>Same as change between 2015 IRC-B and 2018 IRC-B</p>										

Rule 61G20-2.002 2. Technical amendments needed to accommodate the specific needs of this state include but are not limited to amendments to the Florida Building Code that provide for the following: a. Establish minimum life safety construction requirements to protect buildings and their occupants from fire, wind, flood, and storm surge using the latest technical research and engineering standards for buildings and materials products. b. Provide for flood protection provisions that are consistent with the latest flood protection requirements of the National Flood Insurance Program. c. Maintain eligibility for federal funding and discounts from the National Flood Insurance Program, the Federal Emergency Management Agency, and the United States Department of Housing and Urban Development. d. Provide for energy efficiency standards for buildings that meet or exceed the national energy standards as mandated by Title III of the Energy Conservation and Protection Act. e. Maintain coordination with the Florida Fire Prevention Code. f. Provide for the latest industry standards and design

RCCIWG – Comment		TAC Action	Commission Action		TAC	Commission
Impactful (Explain) <input type="checkbox"/>		Accommodate Florida Specific Need: YES (Select Criteria) <input type="checkbox"/> NO: <input type="checkbox"/> a. <input type="checkbox"/> b. <input type="checkbox"/> c. <input type="checkbox"/> d. <input type="checkbox"/> e. <input type="checkbox"/> f. <input type="checkbox"/> Others (Explain): <input type="text"/>	Accommodate Florida Specific Need: YES (Select Criteria) <input type="checkbox"/> NO: <input type="checkbox"/> a. <input type="checkbox"/> b. <input type="checkbox"/> c. <input type="checkbox"/> d. <input type="checkbox"/> e. <input type="checkbox"/> f. <input type="checkbox"/> Others (Explain): <input type="text"/>	<input type="checkbox"/> No Action Needed <input type="checkbox"/> Overlapping provisions	<input type="checkbox"/>	<input type="checkbox"/>
RB284-16	R703.2	Modifies text of Section R703.2 Water-resistive barrier. Adds a water-resistive barrier requirement into R703.2 for detached accessory buildings. Cost Impact: Will not increase the cost of construction. There is no cost impact as the water-resistive barrier is required by the manufacturer and should already be including in the cost of the installation. This code change simply eliminates confusion.	Same as change between 2015 IRC-B and 2018 IRC-B			
Impactful (Explain) <input type="checkbox"/>		Accommodate Florida Specific Need: YES (Select Criteria) <input type="checkbox"/> NO: <input type="checkbox"/> a. <input type="checkbox"/> b. <input type="checkbox"/> c. <input type="checkbox"/> d. <input type="checkbox"/> e. <input type="checkbox"/> f. <input type="checkbox"/> Others (Explain): <input type="text"/>	Accommodate Florida Specific Need: YES (Select Criteria) <input type="checkbox"/> NO: <input type="checkbox"/> a. <input type="checkbox"/> b. <input type="checkbox"/> c. <input type="checkbox"/> d. <input type="checkbox"/> e. <input type="checkbox"/> f. <input type="checkbox"/> Others (Explain): <input type="text"/>	<input type="checkbox"/> No Action Needed <input type="checkbox"/> Overlapping provisions	<input type="checkbox"/>	<input type="checkbox"/>
RB296-16	Table R702.1(3), R703.7, R703.7.1, R703.7.2	Modifies text of Table R702.1 (3) "CEMENT PLASTER PROPORTIONS, PARTS BY VOLUME." Modifies Section R703.7 "Exterior plaster (stucco)", adds exception to R703.7.1 "Lath." Modifies text of R703.7.2 "Plaster". The purpose of this code change is to correlate the requirements for exterior lath and plaster (stucco) with the requirements of ASTM C926 and C1063 and ACI 524R-08 Cost Impact: Will not increase the cost of construction. The code change will not increase the cost of construction. The change corrects the designations for acceptable, currently available cement types clarifies that lath is not required where stucco is permitted to be placed directly on concrete or masonry surfaces.	Same as change between 2015 IRC-B and 2018 IRC-B			

Rule 61G20-2.002 2. Technical amendments needed to accommodate the specific needs of this state include but are not limited to amendments to the Florida Building Code that provide for the following: a. Establish minimum life safety construction requirements to protect buildings and their occupants from fire, wind, flood, and storm surge using the latest technical research and engineering standards for buildings and materials products. b. Provide for flood protection provisions that are consistent with the latest flood protection requirements of the National Flood Insurance Program. c. Maintain eligibility for federal funding and discounts from the National Flood Insurance Program, the Federal Emergency Management Agency, and the United States Department of Housing and Urban Development. d. Provide for energy efficiency standards for buildings that meet or exceed the national energy standards as mandated by Title III of the Energy Conservation and Protection Act. e. Maintain coordination with the Florida Fire Prevention Code. f. Provide for the latest industry standards and design

RCCIWG – Comment		TAC Action	Commission Action		TAC	Commission
Impactful (Explain) <input type="checkbox"/>		Accommodate Florida Specific Need: YES (Select Criteria) <input type="checkbox"/> NO: <input type="checkbox"/> a. <input type="checkbox"/> b. <input type="checkbox"/> c. <input type="checkbox"/> d. <input type="checkbox"/> e. <input type="checkbox"/> f. <input type="checkbox"/> Others (Explain): <input type="text"/>	Accommodate Florida Specific Need: YES (Select Criteria) <input type="checkbox"/> NO: <input type="checkbox"/> a. <input type="checkbox"/> b. <input type="checkbox"/> c. <input type="checkbox"/> d. <input type="checkbox"/> e. <input type="checkbox"/> f. <input type="checkbox"/> Others (Explain): <input type="text"/>	<input type="checkbox"/> No Action Needed <input type="checkbox"/> Overlapping provisions	<input type="checkbox"/>	<input type="checkbox"/>
RB303-16	R703.8.4, R703.8.4(2) (New)	<p>Modifies text of Section R703.8.4 “Anchorage”. Adds Table R703.8.4(2) “BRICK TIE MINIMUM FASTENING REQUIREMENTS (VERTICAL TIE SPACING/ HORIZONTAL TIE SPACING) FOR DIRECT APPLICATION OVER UP TO TWO INCHES OF FOAM TO MINIMUM 7/16 PERFORMANCE CATEGORY WOOD STRUCTURAL PANEL SHEATHING”. The proposed table provides brick-tie attachment recommendations for attachment direct to a minimum 7/16 performance category wood structural panels. As the wood structural panel thickness does not permit the full use of the nail's shank, it is essential that either ring-shank nails or screws be used to keep the brick veneer in place. The code change was further modified by public comment to include Exposure B. The above reflects this change.</p> <p>Cost Impact: <u>Will increase the cost of construction.</u> The proposed change will increase the cost of construction. The increase will be due to the use of ring-shank nails or screws over the more traditional nailed connections. The increase in construction costs can be partially offset by the fact that the builder will not have to locate the studs behind the various materials covering the studs (sheathing, foam, building paper) when attaching the brick ties, as attachment to the studs will not be required. The proposed solution will also eliminate the need to provide extra wall framing just to facilitate the attachment of the brick ties. The use of extra framing adds cost as well as reduces the thermal efficiency of the system.</p>		Same as change between 2015 IRC-B and 2018 IRC-B		

Rule 61G20-2.002 2. Technical amendments needed to accommodate the specific needs of this state include but are not limited to amendments to the Florida Building Code that provide for the following: a. Establish minimum life safety construction requirements to protect buildings and their occupants from fire, wind, flood, and storm surge using the latest technical research and engineering standards for buildings and materials products. b. Provide for flood protection provisions that are consistent with the latest flood protection requirements of the National Flood Insurance Program. c. Maintain eligibility for federal funding and discounts from the National Flood Insurance Program, the Federal Emergency Management Agency, and the United States Department of Housing and Urban Development. d. Provide for energy efficiency standards for buildings that meet or exceed the national energy standards as mandated by Title III of the Energy Conservation and Protection Act. e. Maintain coordination with the Florida Fire Prevention Code. f. Provide for the latest industry standards and design

RCCIWG – Comment		TAC Action		Commission Action			TAC	Commission
Impactful (Explain) <input type="checkbox"/>		Accommodate Florida Specific Need: YES (Select Criteria) <input type="checkbox"/> NO: <input type="checkbox"/> a. <input type="checkbox"/> b. <input type="checkbox"/> c. <input type="checkbox"/> d. <input type="checkbox"/> e. <input type="checkbox"/> f. <input type="checkbox"/> Others (Explain):		Accommodate Florida Specific Need: YES (Select Criteria) <input type="checkbox"/> NO: <input type="checkbox"/> a. <input type="checkbox"/> b. <input type="checkbox"/> c. <input type="checkbox"/> d. <input type="checkbox"/> e. <input type="checkbox"/> f. <input type="checkbox"/> Others (Explain):		<input type="checkbox"/> No Action Needed	<input type="checkbox"/>	<input type="checkbox"/>
						<input type="checkbox"/> Overlapping provisions	<input type="checkbox"/>	<input type="checkbox"/>
RB305-16		R703.11.2, R703.11.2 (New), R703.11.2.1, R703.11.2.2, R703.11.2.3		<p>Modifies text of Section R703.11.2 “Installation over foam plastic sheathing”. Deletes Section R703.11.2.1 “Basic wind speed not exceeding 115 miles per hour and Exposure Category B”, R703.11.2.2 “Basic wind speed exceeding 115 miles per hour or Exposure Categories C and D”. R703.11.2.3 “Manufacturer specification”. Adds Table R703.11.2 “ADJUSTED MINIMUM DESIGN WIND PRESSURE REQUIREMENT FOR VINYL SIDING”. The provisions for application of vinyl siding with foam plastic sheathing are revised to coordinate with changes made last code cycle to address foam sheathing wind pressure resistance in Section R316.8 and to reference the clarified attachment requirements in Section R703.11.1 and R703.3.3. In addition, the proposal improves and simplifies the installation requirements to comply with the latest industry standards. The modification further simplifies by eliminating the modification factor by providing a table to determine design wind pressures. The code change was further modified by the Committee. The modification further simplifies by eliminating the modification factor by providing a table to determine design wind pressures.</p> <p>Cost Impact: Will not increase the cost of construction. This proposal simplifies the code and compliance while maintaining equivalent performance with no cost impact.</p>		This change is not similar to that of the FRC. The FRC provides for Florida specific changes to this section		Overlapping provision to be considered during step 2 of the code change process
Impactful (Explain) <input type="checkbox"/>		Accommodate Florida Specific Need: YES (Select Criteria) <input type="checkbox"/> NO: <input type="checkbox"/> a. <input type="checkbox"/> b. <input type="checkbox"/> c. <input type="checkbox"/> d. <input type="checkbox"/> e. <input type="checkbox"/> f. <input type="checkbox"/> Others (Explain):		Accommodate Florida Specific Need: YES (Select Criteria) <input type="checkbox"/> NO: <input type="checkbox"/> a. <input type="checkbox"/> b. <input type="checkbox"/> c. <input type="checkbox"/> d. <input type="checkbox"/> e. <input type="checkbox"/> f. <input type="checkbox"/> Others (Explain):		<input type="checkbox"/> No Action Needed	<input type="checkbox"/>	<input type="checkbox"/>
						<input type="checkbox"/> Overlapping provisions	<input type="checkbox"/>	<input type="checkbox"/>

Rule 61G20-2.002 2. Technical amendments needed to accommodate the specific needs of this state include but are not limited to amendments to the Florida Building Code that provide for the following: a. Establish minimum life safety construction requirements to protect buildings and their occupants from fire, wind, flood, and storm surge using the latest technical research and engineering standards for buildings and materials products. b. Provide for flood protection provisions that are consistent with the latest flood protection requirements of the National Flood Insurance Program. c. Maintain eligibility for federal funding and discounts from the National Flood Insurance Program, the Federal Emergency Management Agency, and the United States Department of Housing and Urban Development. d. Provide for energy efficiency standards for buildings that meet or exceed the national energy standards as mandated by Title III of the Energy Conservation and Protection Act. e. Maintain coordination with the Florida Fire Prevention Code. f. Provide for the latest industry standards and design

<p>RB307-16</p>	<p>R703.14, R703.14.1, R703.14.1.1, R703.14.1.2, R703.14.3 (New)</p>	<p>Modifies text of R703.14 and adds R703.14.3 “Flame spread index”. Proposal concerning flame spread index of polypropylene and siding. The code change was further modified by the Committee. The modification replicates the IBC language for polypropylene siding.</p> <p>Cost Impact: Will increase the cost of construction. The added requirements are consistent with those in the IBC and with requirements to ensure safe use of polypropylene siding.</p>	<p>Same as change between 2015 IRC-B and 2018 IRC-B</p>			
<p>RCCIWG – Comment</p> <p>Impactful (Explain) <input type="checkbox"/></p>		<p>TAC Action</p> <p>Accommodate Florida Specific Need: YES (Select Criteria) <input type="checkbox"/> NO: <input type="checkbox"/></p> <p>a. <input type="checkbox"/> b. <input type="checkbox"/> c. <input type="checkbox"/> d. <input type="checkbox"/> e. <input type="checkbox"/> f. <input type="checkbox"/></p> <p>Others (Explain):</p>	<p>Commission Action</p> <p>Accommodate Florida Specific Need: YES (Select Criteria) <input type="checkbox"/> NO: <input type="checkbox"/></p> <p>a. <input type="checkbox"/> b. <input type="checkbox"/> c. <input type="checkbox"/> d. <input type="checkbox"/> e. <input type="checkbox"/> f. <input type="checkbox"/></p> <p>Others (Explain):</p>	<p><input type="checkbox"/> No Action Needed</p> <p><input type="checkbox"/> Overlapping provisions</p>	<p>TAC</p> <p><input type="checkbox"/></p> <p><input type="checkbox"/></p>	<p>Commission</p> <p><input type="checkbox"/></p> <p><input type="checkbox"/></p>
<p>RB308-16</p>	<p>R703.15.1, R703.15.2</p>	<p>Modifies text of table R703.15.1 “CLADDING MINIMUM FASTENING REQUIREMENTS FOR DIRECT ATTACHMENT OVER FOAM PLASTIC SHEATHING TO SUPPORT CLADDING WEIGHT” and table R703.15.2 “FURRING MINIMUM FASTENING REQUIREMENTS FOR APPLICATION OVER FOAM PLASTIC SHEATHING TO SUPPORT CLADDING WEIGHT”.</p> <p>This proposal updates the table values to a consistent rounding approach by rounding the values down to the nearest 0.05" to address actual thicknesses of foam sheathing materials that often vary from nominal dimensions such as 0.5", 1", 1.5" 2", 3" and 4" as used in the existing table.</p> <p>Cost Impact: Will not increase the cost of construction. The proposal adds an additional option (18 psf cladding weight) and does not increase cost.</p>	<p>Same as change between 2015 IRC-B and 2018 IRC-B</p>			

Rule 61G20-2.002 2. Technical amendments needed to accommodate the specific needs of this state include but are not limited to amendments to the Florida Building Code that provide for the following: a. Establish minimum life safety construction requirements to protect buildings and their occupants from fire, wind, flood, and storm surge using the latest technical research and engineering standards for buildings and materials products. b. Provide for flood protection provisions that are consistent with the latest flood protection requirements of the National Flood Insurance Program. c. Maintain eligibility for federal funding and discounts from the National Flood Insurance Program, the Federal Emergency Management Agency, and the United States Department of Housing and Urban Development. d. Provide for energy efficiency standards for buildings that meet or exceed the national energy standards as mandated by Title III of the Energy Conservation and Protection Act. e. Maintain coordination with the Florida Fire Prevention Code. f. Provide for the latest industry standards and design

RCCIWG – Comment		TAC Action	Commission Action		TAC	Commission
Impactful (Explain) <input type="checkbox"/>		Accommodate Florida Specific Need: YES (Select Criteria) <input type="checkbox"/> NO: <input type="checkbox"/> a. <input type="checkbox"/> b. <input type="checkbox"/> c. <input type="checkbox"/> d. <input type="checkbox"/> e. <input type="checkbox"/> f. <input type="checkbox"/> Others (Explain):	Accommodate Florida Specific Need: YES (Select Criteria) <input type="checkbox"/> NO: <input type="checkbox"/> a. <input type="checkbox"/> b. <input type="checkbox"/> c. <input type="checkbox"/> d. <input type="checkbox"/> e. <input type="checkbox"/> f. <input type="checkbox"/> Others (Explain):	<input type="checkbox"/> No Action Needed	<input type="checkbox"/>	<input type="checkbox"/>
				<input type="checkbox"/> Overlapping provisions	<input type="checkbox"/>	<input type="checkbox"/>
RB309-16	R703.16.1, R703.16.2	Modifies text of Table R703.16.1 “CLADDING MINIMUM FASTENING REQUIREMENTS FOR DIRECT ATTACHMENT OVER FOAM PLASTIC SHEATHING TO SUPPORT CLADDING WEIGHT” and table R703.16.2 “FURRING MINIMUM FASTENING REQUIREMENTS FOR APPLICATION OVER FOAM PLASTIC SHEATHING TO SUPPORT CLADDING WEIGHT”. This proposal updates the table values to a consistent rounding approach by rounding the values down to the nearest 0.05" to address actual thicknesses of foam sheathing materials that often vary from nominal dimensions such as 0.5", 1", 1.5", 2", 3", and 4" as used in the existing table. Cost Impact: Will not increase the cost of construction. This proposal adds an additional option (18 psf cladding weight) and does not increase cost.	Same as change between 2015 IRC-B and 2018 IRC-B			
Impactful (Explain) <input type="checkbox"/>		Accommodate Florida Specific Need: YES (Select Criteria) <input type="checkbox"/> NO: <input type="checkbox"/> a. <input type="checkbox"/> b. <input type="checkbox"/> c. <input type="checkbox"/> d. <input type="checkbox"/> e. <input type="checkbox"/> f. <input type="checkbox"/> Others (Explain):	Accommodate Florida Specific Need: YES (Select Criteria) <input type="checkbox"/> NO: <input type="checkbox"/> a. <input type="checkbox"/> b. <input type="checkbox"/> c. <input type="checkbox"/> d. <input type="checkbox"/> e. <input type="checkbox"/> f. <input type="checkbox"/> Others (Explain):	<input type="checkbox"/> No Action Needed	<input type="checkbox"/>	<input type="checkbox"/>
				<input type="checkbox"/> Overlapping provisions	<input type="checkbox"/>	<input type="checkbox"/>
RB310-16	R802, R802.2, R802.3, R802.3 (New), R802.3.1, R802.3.2, R802.3.3, R802.4,	Modifies text of Section R802 “Wood Roof Framing”, R802.3 “Ridge”, R802.4 “Rafters”, R802.4.1 “Rafter size”, R802.4.2 “Framing details”, R802.4.3 “Hips and Valleys”, R802.4.4 “Rafter supports”, R802.4.5 “Purlins”, R802.4.6 “Collar ties”, R802.5 “Ceiling joists”, R802.5.1 “Ceiling joist size”, R802.5.2 “Ceiling joist and rafter connections”, R802.5.2.1 “Ceiling joists lapped”, R802.5.2.2 “Rafter ties”, R802.5.2.3 “Blocking”.	Same as change between 2015 IRC-B and 2018 IRC-B	No action needed		As per R301.2.1.1 of the 2017 FRC, these sections are part of those prescriptive provisions that are not applicable to

Rule 61G20-2.002 2. Technical amendments needed to accommodate the specific needs of this state include but are not limited to amendments to the Florida Building Code that provide for the following: a. Establish minimum life safety construction requirements to protect buildings and their occupants from fire, wind, flood, and storm surge using the latest technical research and engineering standards for buildings and materials products. b. Provide for flood protection provisions that are consistent with the latest flood protection requirements of the National Flood Insurance Program. c. Maintain eligibility for federal funding and discounts from the National Flood Insurance Program, the Federal Emergency Management Agency, and the United States Department of Housing and Urban Development. d. Provide for energy efficiency standards for buildings that meet or exceed the national energy standards as mandated by Title III of the Energy Conservation and Protection Act. e. Maintain coordination with the Florida Fire Prevention Code. f. Provide for the latest industry standards and design

	<p>R802.4 (New), R802.4.3 (New), R802.4.4 (New), R802.4.6 (New), R802.5, R802.5 (New), R802.5.1, R802.5.2.2 (New)</p>	<p>Renumber the following tables: R802.4(1) as R802.5.1(1) - no change to table. R802.4(2) as R802.5.1(2) - no change to table. R802.5.1(1) as R802.4.1(1) - no change to table. R802.5.1(2) as R802.4.1(2) - no change to table. R802.5.1(3) as R802.4.1(3) - no change to table. R802.5.1(4) as R802.4.1(4) - no change to table. R802.5.1(5) as R802.4.1(5) - no change to table. R802.5.1(6) as R802.4.1(6) - no change to table. R802.5.1(7) as R802.4.1(7) - no change to table. R802.5.1(8) as R802.4.1(8) - no change to table. R802.5.1(9) as R802.5.2 - no change to table.</p> <p>Renumber Figure R802.5.1 as R802.4.5 and delete all cross references to section numbers from the table. Deletes "Note: Where ceiling joists...". Renumber the cross reference in Table R602.3(1), item 4: Table R802.5.1(9) as R802.5.2</p> <p>This code proposal is a rewrite with minor technical changes. It is intended to reorganize the roof and ceiling assembly by separating out the requirements of the components:</p> <p>R802.3 Ridge R802.4 Rafters R802.5 Ceiling joists</p> <p>The code change was further modified by the Committee. The modifications clarifies the continuous ties, provides a pointer for the ridge strap back to the fastener table and adds the requirement for bearing for beams of roofs with slope less than 3:12.</p> <p>Cost Impact: Will not increase the cost of construction. This rewrite is essentially a non-technical code change intended to reorganize the section by components of the roof-ceiling assembly. It should not impact the cost of roof construction.</p>		<p>Florida.</p>
--	--	--	--	-----------------

Rule 61G20-2.002 2. Technical amendments needed to accommodate the specific needs of this state include but are not limited to amendments to the Florida Building Code that provide for the following: a. Establish minimum life safety construction requirements to protect buildings and their occupants from fire, wind, flood, and storm surge using the latest technical research and engineering standards for buildings and materials products. b. Provide for flood protection provisions that are consistent with the latest flood protection requirements of the National Flood Insurance Program. c. Maintain eligibility for federal funding and discounts from the National Flood Insurance Program, the Federal Emergency Management Agency, and the United States Department of Housing and Urban Development. d. Provide for energy efficiency standards for buildings that meet or exceed the national energy standards as mandated by Title III of the Energy Conservation and Protection Act. e. Maintain coordination with the Florida Fire Prevention Code. f. Provide for the latest industry standards and design

RCCIWG – Comment		TAC Action	Commission Action		TAC	Commission
Impactful (Explain) <input type="checkbox"/>		Accommodate Florida Specific Need: YES (Select Criteria) <input type="checkbox"/> NO: <input type="checkbox"/> a. <input type="checkbox"/> b. <input type="checkbox"/> c. <input type="checkbox"/> d. <input type="checkbox"/> e. <input type="checkbox"/> f. <input type="checkbox"/> Others (Explain): <input type="text"/>	Accommodate Florida Specific Need: YES (Select Criteria) <input type="checkbox"/> NO: <input type="checkbox"/> a. <input type="checkbox"/> b. <input type="checkbox"/> c. <input type="checkbox"/> d. <input type="checkbox"/> e. <input type="checkbox"/> f. <input type="checkbox"/> Others (Explain): <input type="text"/>	<input type="checkbox"/> No Action Needed <input type="checkbox"/> Overlapping provisions	<input type="checkbox"/>	<input type="checkbox"/>
RB314-16	R802.1.5.4	Modifies text of Section R802.1.5.4 Labeling. This change clarifies that FRTW must have two labels: one for the grading of the wood, the other for the treatment. There are also manufacturers making the claim for a lift of lumber or wood structural panel. The change clarifies each piece must be labeled with both marks. Cost Impact: Will not increase the cost of construction. Manufacturer's treating in accordance with the code requirement for pressure treatment or other means during manufacturer already mark each piece. The proposal clarifies , for others, what is already being done.	Same as change between 2015 IRC-B and 2018 IRC-B	No action needed As per R301.2.1.1 of the 2017 FRC, this section is part of those prescriptive provisions that are not applicable to Florida.		
Impactful (Explain) <input type="checkbox"/>		Accommodate Florida Specific Need: YES (Select Criteria) <input type="checkbox"/> NO: <input type="checkbox"/> a. <input type="checkbox"/> b. <input type="checkbox"/> c. <input type="checkbox"/> d. <input type="checkbox"/> e. <input type="checkbox"/> f. <input type="checkbox"/> Others (Explain): <input type="text"/>	Accommodate Florida Specific Need: YES (Select Criteria) <input type="checkbox"/> NO: <input type="checkbox"/> a. <input type="checkbox"/> b. <input type="checkbox"/> c. <input type="checkbox"/> d. <input type="checkbox"/> e. <input type="checkbox"/> f. <input type="checkbox"/> Others (Explain): <input type="text"/>	<input type="checkbox"/> No Action Needed <input type="checkbox"/> Overlapping provisions	<input type="checkbox"/>	<input type="checkbox"/>
RB315-16	R802.1.8	Adds new Section R802.1.8 Prefabricated wood I-joists. This proposal adds prefabricated wood I-joists to the list of wood and wood-based products listed in the IRC for roof framing. Cost Impact: Will not increase the cost of construction.	Same as change between 2015 IRC-B and 2018 IRC-B	No action needed As per R301.2.1.1 of the 2017 FRC, this section is part of those prescriptive provisions that are not applicable to Florida.		

Rule 61G20-2.002 2. Technical amendments needed to accommodate the specific needs of this state include but are not limited to amendments to the Florida Building Code that provide for the following: a. Establish minimum life safety construction requirements to protect buildings and their occupants from fire, wind, flood, and storm surge using the latest technical research and engineering standards for buildings and materials products. b. Provide for flood protection provisions that are consistent with the latest flood protection requirements of the National Flood Insurance Program. c. Maintain eligibility for federal funding and discounts from the National Flood Insurance Program, the Federal Emergency Management Agency, and the United States Department of Housing and Urban Development. d. Provide for energy efficiency standards for buildings that meet or exceed the national energy standards as mandated by Title III of the Energy Conservation and Protection Act. e. Maintain coordination with the Florida Fire Prevention Code. f. Provide for the latest industry standards and design

RCCIWG – Comment		TAC Action	Commission Action		TAC	Commission
Impactful (Explain) <input type="checkbox"/>		Accommodate Florida Specific Need: YES (Select Criteria) <input type="checkbox"/> NO: <input type="checkbox"/> a. <input type="checkbox"/> b. <input type="checkbox"/> c. <input type="checkbox"/> d. <input type="checkbox"/> e. <input type="checkbox"/> f. <input type="checkbox"/> Others (Explain):	Accommodate Florida Specific Need: YES (Select Criteria) <input type="checkbox"/> NO: <input type="checkbox"/> a. <input type="checkbox"/> b. <input type="checkbox"/> c. <input type="checkbox"/> d. <input type="checkbox"/> e. <input type="checkbox"/> f. <input type="checkbox"/> Others (Explain):	<input type="checkbox"/> No Action Needed	<input type="checkbox"/>	<input type="checkbox"/>
				<input type="checkbox"/> Overlapping provisions	<input type="checkbox"/>	<input type="checkbox"/>
RB319-16	R802.5.1	Modifies text of Section TABLE R802.5.1 (9) “RAFTER/CEILING JOIST HEEL JOINT CONNECTIONS”. Footnote “f” should have been removed at the time footnote “h” was added to better account for the effect of rafter ties located above the bottom of the attic space. Proposal to address this. Cost Impact: Will not increase the cost of construction.	Same as change between 2015 IRC-B and 2018 IRC-B	No action needed As per R301.2.1.1 of the 2017 FRC, this section is part of those prescriptive provisions that are not applicable to Florida.		
Impactful (Explain) <input type="checkbox"/>		Accommodate Florida Specific Need: YES (Select Criteria) <input type="checkbox"/> NO: <input type="checkbox"/> a. <input type="checkbox"/> b. <input type="checkbox"/> c. <input type="checkbox"/> d. <input type="checkbox"/> e. <input type="checkbox"/> f. <input type="checkbox"/> Others (Explain):	Accommodate Florida Specific Need: YES (Select Criteria) <input type="checkbox"/> NO: <input type="checkbox"/> a. <input type="checkbox"/> b. <input type="checkbox"/> c. <input type="checkbox"/> d. <input type="checkbox"/> e. <input type="checkbox"/> f. <input type="checkbox"/> Others (Explain):	<input type="checkbox"/> No Action Needed	<input type="checkbox"/>	<input type="checkbox"/>
				<input type="checkbox"/> Overlapping provisions	<input type="checkbox"/>	<input type="checkbox"/>
RB321-16	R804.1.1, R804.3.1.1, R804.3.2.1, R804.3.6, R804.3.7.1	Modifies text of Section R804.1.1 “Applicability limits”, R804.3.1.1 “Minimum ceiling joist size”, R804.3.6 “Roof trusses”. Revises Table R804.3.1.1(1) “CEILING JOIST SPANS 10 PSF LIVE LOAD (NO ATTIC STORAGE”, TABLE R804.3.1.1 (2) “CEILING JOIST SPANS 20 PSF LIVE LOAD (LIMITED ATTIC STORAGE”, TABLE R804.3.2.1 (1) “ROOF RAFTER SPANS”, TABLE R804.3.2.1 (2) “ULTIMATE DESIGN WIND SPEED TO EQUIVALENT SNOW LOAD CONVERSION”, TABLE 804.3.7.1 “REQUIRED LENGTHS FOR CEILING DIAPHRAGMS AT GABLE ENDWALLS GYPSUM BOARD SHEATHED, CEILING HEIGHT”. Adds new standard “AISI S240-15, North American Standard for Cold-Formed Steel Structural Framing (2015)”. The proposed revisions align the IRC with the provisions of AISI S230-15, “Standard for Cold-Formed Steel Framing - Prescriptive Method for One- and Two-Family Dwellings”. The	Same as change between 2015 IRC-B and 2018 IRC-B	No action needed As per R301.2.1.1 of the 2017 FRC, these sections are part of those prescriptive provisions that are not applicable to Florida.		

Rule 61G20-2.002 2. Technical amendments needed to accommodate the specific needs of this state include but are not limited to amendments to the Florida Building Code that provide for the following: a. Establish minimum life safety construction requirements to protect buildings and their occupants from fire, wind, flood, and storm surge using the latest technical research and engineering standards for buildings and materials products. b. Provide for flood protection provisions that are consistent with the latest flood protection requirements of the National Flood Insurance Program. c. Maintain eligibility for federal funding and discounts from the National Flood Insurance Program, the Federal Emergency Management Agency, and the United States Department of Housing and Urban Development. d. Provide for energy efficiency standards for buildings that meet or exceed the national energy standards as mandated by Title III of the Energy Conservation and Protection Act. e. Maintain coordination with the Florida Fire Prevention Code. f. Provide for the latest industry standards and design

		<p>wind loads are adjusted to conform to the provisions of the ASCE 7-10 Directional Procedure, and the wind speed increments are modified to correlate with increments as shown in the wind speed maps (Figures R301.2(4)A and B).</p> <p>Cost Impact: Will increase the cost of construction. The proposed changes to this section will not increase the cost of construction in general. While the overwhelming majority of the prescribed members have not changed or are reduced in size, there may be conditions for which the minimum member size will increase.</p>		
--	--	--	--	--

RCCIWG – Comment	TAC Action	Commission Action	TAC	Commission
Impactful (Explain) <input type="checkbox"/>	Accommodate Florida Specific Need: YES (Select Criteria) <input type="checkbox"/> NO: <input type="checkbox"/> a. <input type="checkbox"/> b. <input type="checkbox"/> c. <input type="checkbox"/> d. <input type="checkbox"/> e. <input type="checkbox"/> f. <input type="checkbox"/> Others (Explain): <input type="text"/>	Accommodate Florida Specific Need: YES (Select Criteria) <input type="checkbox"/> NO: <input type="checkbox"/> a. <input type="checkbox"/> b. <input type="checkbox"/> c. <input type="checkbox"/> d. <input type="checkbox"/> e. <input type="checkbox"/> f. <input type="checkbox"/> Others (Explain): <input type="text"/>	<input type="checkbox"/> No Action Needed <input type="checkbox"/> Overlapping provisions	<input type="checkbox"/> <input type="checkbox"/>

RB323-16	R806.1, R806.3	<p>Modifies text of Section R806.1 “Ventilation required”, R806.3 “Vent and insulation clearance”. This proposal is editorial and will bring the IRC requirements into alignment with the IBC ventilation requirements.</p> <p>Cost Impact: Will not increase the cost of construction. The proposal is editorial and adds no additional requirements.</p>	Same as change between 2015 IRC-B and 2018 IRC-B	
----------	----------------	--	--	--

RCCIWG – Comment	TAC Action	Commission Action	TAC	Commission
Impactful (Explain) <input type="checkbox"/>	Accommodate Florida Specific Need: YES (Select Criteria) <input type="checkbox"/> NO: <input type="checkbox"/> a. <input type="checkbox"/> b. <input type="checkbox"/> c. <input type="checkbox"/> d. <input type="checkbox"/> e. <input type="checkbox"/> f. <input type="checkbox"/> Others (Explain): <input type="text"/>	Accommodate Florida Specific Need: YES (Select Criteria) <input type="checkbox"/> NO: <input type="checkbox"/> a. <input type="checkbox"/> b. <input type="checkbox"/> c. <input type="checkbox"/> d. <input type="checkbox"/> e. <input type="checkbox"/> f. <input type="checkbox"/> Others (Explain): <input type="text"/>	<input type="checkbox"/> No Action Needed <input type="checkbox"/> Overlapping provisions	<input type="checkbox"/> <input type="checkbox"/>

Rule 61G20-2.002 2. Technical amendments needed to accommodate the specific needs of this state include but are not limited to amendments to the Florida Building Code that provide for the following:

a. Establish minimum life safety construction requirements to protect buildings and their occupants from fire, wind, flood, and storm surge using the latest technical research and engineering standards for buildings and materials products. b. Provide for flood protection provisions that are consistent with the latest flood protection requirements of the National Flood Insurance Program. c. Maintain eligibility for federal funding and discounts from the National Flood Insurance Program, the Federal Emergency Management Agency, and the United States Department of Housing and Urban Development. d. Provide for energy efficiency standards for buildings that meet or exceed the national energy standards as mandated by Title III of the Energy Conservation and Protection Act. e. Maintain coordination with the Florida Fire Prevention Code. f. Provide for the latest industry standards and design

<p>RB324-16</p>	<p>R806.2</p>	<p>Modifies text of Section R806.2 “Minimum vent area”. The proposal is a clarification to align the IRC with the IBC requirements for the reduction in ventilation area.</p> <p>Cost Impact: Will increase the cost of construction. The proposal may increase the cost of construction due to additional requirements to reduce the net free vent area.</p>	<p>Same as change between 2015 IRC-B and 2018 IRC-B</p>		
<p>RCCIWG – Comment</p> <p>Impactful (Explain) <input type="checkbox"/></p>	<p>TAC Action</p> <p>Accommodate Florida Specific Need: YES (Select Criteria) <input type="checkbox"/> NO: <input type="checkbox"/> a. <input type="checkbox"/> b. <input type="checkbox"/> c. <input type="checkbox"/> d. <input type="checkbox"/> e. <input type="checkbox"/> f. <input type="checkbox"/> Others (Explain):</p>	<p>Commission Action</p> <p>Accommodate Florida Specific Need: YES (Select Criteria) <input type="checkbox"/> NO: <input type="checkbox"/> a. <input type="checkbox"/> b. <input type="checkbox"/> c. <input type="checkbox"/> d. <input type="checkbox"/> e. <input type="checkbox"/> f. <input type="checkbox"/> Others (Explain):</p>	<p><input type="checkbox"/> No Action Needed</p> <p><input type="checkbox"/> Overlapping provisions</p>	<p>TAC</p> <p><input type="checkbox"/></p> <p><input type="checkbox"/></p>	<p>Commission</p> <p><input type="checkbox"/></p> <p><input type="checkbox"/></p>
<p>RB325-16</p>	<p>R806.2</p>	<p>Modifies text of Section R806.2 “Minimum vent area”. Due to property line separation requirements, restricting the lower vents to the eave or cornice, may not be achievable. The intent of this change does not restrict the use of eave or cornice vents when they are located in the bottom 1/3 of the attic space</p> <p>Cost Impact: Will not increase the cost of construction. Design flexibility will not increase costs.</p>	<p>Same as change between 2015 IRC-B and 2018 IRC-B</p>		
<p>RCCIWG – Comment</p> <p>Impactful (Explain) <input type="checkbox"/></p>	<p>TAC Action</p> <p>Accommodate Florida Specific Need: YES (Select Criteria) <input type="checkbox"/> NO: <input type="checkbox"/> a. <input type="checkbox"/> b. <input type="checkbox"/> c. <input type="checkbox"/> d. <input type="checkbox"/> e. <input type="checkbox"/> f. <input type="checkbox"/> Others (Explain):</p>	<p>Commission Action</p> <p>Accommodate Florida Specific Need: YES (Select Criteria) <input type="checkbox"/> NO: <input type="checkbox"/> a. <input type="checkbox"/> b. <input type="checkbox"/> c. <input type="checkbox"/> d. <input type="checkbox"/> e. <input type="checkbox"/> f. <input type="checkbox"/> Others (Explain):</p>	<p><input type="checkbox"/> No Action Needed</p> <p><input type="checkbox"/> Overlapping provisions</p>	<p>TAC</p> <p><input type="checkbox"/></p> <p><input type="checkbox"/></p>	<p>Commission</p> <p><input type="checkbox"/></p> <p><input type="checkbox"/></p>
<p>RB326-16</p>	<p>R806.5</p>	<p>Modifies text of Section R806.5 Unvented attic and unvented enclosed rafter assemblies. This is an editorial improvement, which makes the code clearer. There is no change in the requirements.</p> <p>Cost Impact: Will not increase the cost of construction. This clarifies the code.</p>	<p>Same as change between 2015 IRC-B and 2018 IRC-B</p>		

Rule 61G20-2.002 2. Technical amendments needed to accommodate the specific needs of this state include but are not limited to amendments to the Florida Building Code that provide for the following: a. Establish minimum life safety construction requirements to protect buildings and their occupants from fire, wind, flood, and storm surge using the latest technical research and engineering standards for buildings and materials products. b. Provide for flood protection provisions that are consistent with the latest flood protection requirements of the National Flood Insurance Program. c. Maintain eligibility for federal funding and discounts from the National Flood Insurance Program, the Federal Emergency Management Agency, and the United States Department of Housing and Urban Development. d. Provide for energy efficiency standards for buildings that meet or exceed the national energy standards as mandated by Title III of the Energy Conservation and Protection Act. e. Maintain coordination with the Florida Fire Prevention Code. f. Provide for the latest industry standards and design

RCCIWG – Comment		TAC Action	Commission Action		TAC	Commission
Impactful (Explain) <input type="checkbox"/>		Accommodate Florida Specific Need: YES (Select Criteria) <input type="checkbox"/> NO: <input type="checkbox"/> a. <input type="checkbox"/> b. <input type="checkbox"/> c. <input type="checkbox"/> d. <input type="checkbox"/> e. <input type="checkbox"/> f. <input type="checkbox"/> Others (Explain): <input type="text"/>	Accommodate Florida Specific Need: YES (Select Criteria) <input type="checkbox"/> NO: <input type="checkbox"/> a. <input type="checkbox"/> b. <input type="checkbox"/> c. <input type="checkbox"/> d. <input type="checkbox"/> e. <input type="checkbox"/> f. <input type="checkbox"/> Others (Explain): <input type="text"/>	<input type="checkbox"/> No Action Needed <input type="checkbox"/> Overlapping provisions	<input type="checkbox"/>	<input type="checkbox"/>
RB327-16	R202 (New), R806.5	Modifies text of Section R806.5 “Unvented attic and unvented enclosed rafter assemblies”. Adds new definition “Vapor Diffusion Port”. The proposed code change allows the use of lower cost alternatives. Specifically, the proposed code change allows the use of fiberglass batts, blown cellulose and blown fiberglass to construct unvented attic assemblies. Cost Impact: Will not increase the cost of construction. This will provide options.	Same as change between 2015 IRC-B and 2018 IRC-B			
Impactful (Explain) <input type="checkbox"/>		Accommodate Florida Specific Need: YES (Select Criteria) <input type="checkbox"/> NO: <input type="checkbox"/> a. <input type="checkbox"/> b. <input type="checkbox"/> c. <input type="checkbox"/> d. <input type="checkbox"/> e. <input type="checkbox"/> f. <input type="checkbox"/> Others (Explain): <input type="text"/>	Accommodate Florida Specific Need: YES (Select Criteria) <input type="checkbox"/> NO: <input type="checkbox"/> a. <input type="checkbox"/> b. <input type="checkbox"/> c. <input type="checkbox"/> d. <input type="checkbox"/> e. <input type="checkbox"/> f. <input type="checkbox"/> Others (Explain): <input type="text"/>	<input type="checkbox"/> No Action Needed <input type="checkbox"/> Overlapping provisions	<input type="checkbox"/>	<input type="checkbox"/>
RB359-16	R1005.8	Adds new Section R1005.8 “Insulation shield”. Proposal to address insulation shield for factory-built chimneys. Cost Impact: Will not increase the cost of construction. Will not increase cost as the insulation shield should already be used, however, when the code does not call it out as required many times it gets overlooked.	Same as change between 2015 IRC-B and 2018 IRC-B			
Impactful (Explain) <input type="checkbox"/>		Accommodate Florida Specific Need: YES (Select Criteria) <input type="checkbox"/> NO: <input type="checkbox"/> a. <input type="checkbox"/> b. <input type="checkbox"/> c. <input type="checkbox"/> d. <input type="checkbox"/> e. <input type="checkbox"/> f. <input type="checkbox"/> Others (Explain): <input type="text"/>	Accommodate Florida Specific Need: YES (Select Criteria) <input type="checkbox"/> NO: <input type="checkbox"/> a. <input type="checkbox"/> b. <input type="checkbox"/> c. <input type="checkbox"/> d. <input type="checkbox"/> e. <input type="checkbox"/> f. <input type="checkbox"/> Others (Explain): <input type="text"/>	<input type="checkbox"/> No Action Needed <input type="checkbox"/> Overlapping provisions	<input type="checkbox"/>	<input type="checkbox"/>

Rule 61G20-2.002 2. Technical amendments needed to accommodate the specific needs of this state include but are not limited to amendments to the Florida Building Code that provide for the following: a. Establish minimum life safety construction requirements to protect buildings and their occupants from fire, wind, flood, and storm surge using the latest technical research and engineering standards for buildings and materials products. b. Provide for flood protection provisions that are consistent with the latest flood protection requirements of the National Flood Insurance Program. c. Maintain eligibility for federal funding and discounts from the National Flood Insurance Program, the Federal Emergency Management Agency, and the United States Department of Housing and Urban Development. d. Provide for energy efficiency standards for buildings that meet or exceed the national energy standards as mandated by Title III of the Energy Conservation and Protection Act. e. Maintain coordination with the Florida Fire Prevention Code. f. Provide for the latest industry standards and design

RB360-16	AE101.1,AE101.2	<p>Modifies Section AE101.1 “General”. Adds new Section AE101.2 “Flood hazard areas”. This proposal is editorial. The text current in an exception should be a separate section. It is not good code writing to have an exception written to add to the basic requirement.</p> <p>Cost Impact: Will not increase the cost of construction. Proposal only clarifies and puts the provision in proper format.</p>											
<p>RCCIWG – Comment</p> <p>Impactful (Explain) <input type="checkbox"/></p>		<p>TAC Action</p> <p>Accommodate Florida Specific Need: YES (Select Criteria) <input type="checkbox"/> NO: <input type="checkbox"/></p> <p>a. <input type="checkbox"/> b. <input type="checkbox"/> c. <input type="checkbox"/> d. <input type="checkbox"/> e. <input type="checkbox"/> f. <input type="checkbox"/></p> <p>Others (Explain):</p>	<p>Commission Action</p> <p>Accommodate Florida Specific Need: YES (Select Criteria) <input type="checkbox"/> NO: <input type="checkbox"/></p> <p>a. <input type="checkbox"/> b. <input type="checkbox"/> c. <input type="checkbox"/> d. <input type="checkbox"/> e. <input type="checkbox"/> f. <input type="checkbox"/></p> <p>Others (Explain):</p>	<table border="1"> <thead> <tr> <th></th> <th>TAC</th> <th>Commission</th> </tr> </thead> <tbody> <tr> <td><input type="checkbox"/> No Action Needed</td> <td><input type="checkbox"/></td> <td><input type="checkbox"/></td> </tr> <tr> <td><input type="checkbox"/> Overlapping provisions</td> <td><input type="checkbox"/></td> <td><input type="checkbox"/></td> </tr> </tbody> </table>		TAC	Commission	<input type="checkbox"/> No Action Needed	<input type="checkbox"/>	<input type="checkbox"/>	<input type="checkbox"/> Overlapping provisions	<input type="checkbox"/>	<input type="checkbox"/>
	TAC	Commission											
<input type="checkbox"/> No Action Needed	<input type="checkbox"/>	<input type="checkbox"/>											
<input type="checkbox"/> Overlapping provisions	<input type="checkbox"/>	<input type="checkbox"/>											
RB365-16	<p>202, AR101, AR101.1, AR102, AR102.1, AR103, AR103.1, AR103.2, AR103.2.1, AR103.2.2, AR103.2.3, AR103.2.3 (New), AR103.2.4, AR103.2.4(1) (New), AR103.2.4(2) (New), AR103.2.4(3) (New), AR103.3, AR103.3.1, AR103.3.2, AR103.3.3, AR103.3.4,</p>	<p>Modifies Section AR101.1 “Scope”, AR103.2.2 “Bracing”, AR103.2.3 “Requirements and properties of light straw-clay mixtures”, AR103.2.4 “Stabilization of light straw-clay”, AR103.3 “Materials”, AR103.3.1 “Straw requirements”, AR103.3.2 “Clay subsoil requirements”, AR103.3.3 “Light straw-clay mixture”, AR103.4 “Wall construction”, AR103.4.1 “Light straw-clay maximum thickness”, AR103.4.6 “Installation”, AR103.5.1 “Dimensional stability of light straw-clay prior to application of plaster finish”, AR103.5.2 “Plaster finish”, AR103.5.5 “Exterior cladding”, Section AR104 “Thermal Performance”, AR104.1 “Thermal characteristics”, AR104.2 “Thermal resistance”.</p> <p>Modifies definitions of Section AR102. “CLAY SLIP”, “CLAY SUBSOIL”, “INFILL”, “LIGHT STRAW-CLAY”, “VOID”. Modifies Table AR103.2.3 “REQUIREMENTS AND PROPERTIES OF LIGHT STRAW-CLAY MIXTURES”. Modifies Figure R103.2.4(1) “ LIGHT STRAW-CLAY WALL WITH LARSEN TRUSSES”, Figure AR103.2.4(2) “LIGHT STRAW-CLAY WALL SINGLE STUD WIDTH”, FIGURE AR103.2.4(3) “LIGHT STRAW-CLAY WALL WITH BLIND STUDS”. Deletes Section AR103.3.3 “Clay slip” and Section AR105 “REFERENCED STANDARD”.</p> <p>Updates to Appendix R Light Straw Clay Construction will</p>	<p>Same as change between 2015 IRC-B and 2018 IRC-B</p> <p>Updates to Appendix R</p>										

Rule 61G20-2.002 2. Technical amendments needed to accommodate the specific needs of this state include but are not limited to amendments to the Florida Building Code that provide for the following: a. Establish minimum life safety construction requirements to protect buildings and their occupants from fire, wind, flood, and storm surge using the latest technical research and engineering standards for buildings and materials products. b. Provide for flood protection provisions that are consistent with the latest flood protection requirements of the National Flood Insurance Program. c. Maintain eligibility for federal funding and discounts from the National Flood Insurance Program, the Federal Emergency Management Agency, and the United States Department of Housing and Urban Development. d. Provide for energy efficiency standards for buildings that meet or exceed the national energy standards as mandated by Title III of the Energy Conservation and Protection Act. e. Maintain coordination with the Florida Fire Prevention Code. f. Provide for the latest industry standards and design

	AR103.4, AR103.4.1, AR103.4.2, AR103.4.3, AR103.4.4, AR103.4.5, AR103.4.6, AR103.4.7, AR103.5, AR103.5.1, AR103.5.2, AR103.5.3, AR103.5.4, AR103.5.5, AR104, AR104.1, AR104.2 (New), AR105	provide clarification and incorporate new scientific information regarding material performance and construction methodology. This proposal adds new Figures and a Table, information previously published in the 2015 IRC Commentary Appendix R, and proposes text changes to certain Sections to coordinate with same. Cost Impact: Will not increase the cost of construction.											
RCCIWG – Comment Impactful (Explain) <input type="checkbox"/>	TAC Action Accommodate Florida Specific Need: YES (Select Criteria) <input type="checkbox"/> NO: <input type="checkbox"/> a. <input type="checkbox"/> b. <input type="checkbox"/> c. <input type="checkbox"/> d. <input type="checkbox"/> e. <input type="checkbox"/> f. <input type="checkbox"/> Others (Explain): _____	Commission Action Accommodate Florida Specific Need: YES (Select Criteria) <input type="checkbox"/> NO: <input type="checkbox"/> a. <input type="checkbox"/> b. <input type="checkbox"/> c. <input type="checkbox"/> d. <input type="checkbox"/> e. <input type="checkbox"/> f. <input type="checkbox"/> Others (Explain): _____	<input type="checkbox"/> No Action Needed <input type="checkbox"/> Overlapping provisions	<table border="1"> <thead> <tr> <th></th> <th>TAC</th> <th>Commission</th> </tr> </thead> <tbody> <tr> <td><input type="checkbox"/> No Action Needed</td> <td><input type="checkbox"/></td> <td><input type="checkbox"/></td> </tr> <tr> <td><input type="checkbox"/> Overlapping provisions</td> <td><input type="checkbox"/></td> <td><input type="checkbox"/></td> </tr> </tbody> </table>		TAC	Commission	<input type="checkbox"/> No Action Needed	<input type="checkbox"/>	<input type="checkbox"/>	<input type="checkbox"/> Overlapping provisions	<input type="checkbox"/>	<input type="checkbox"/>
	TAC	Commission											
<input type="checkbox"/> No Action Needed	<input type="checkbox"/>	<input type="checkbox"/>											
<input type="checkbox"/> Overlapping provisions	<input type="checkbox"/>	<input type="checkbox"/>											
RB366-16	AS101.1, AS102.1, AS103.4, AS103.5, AS104.4.5, AS104.4.6, AS104.4.8, AS105.2, AS105.4, AS105.4.1, AS105.4.2, AS105.6.4, AS105.6.8, AS105.8 (New),	Modifies definitions of Section AS102.1 Definitions, LAID FLAT, MESH, ON-EDGE. , “PLASTER”. Modifies Section AS103.4 “Moisture content”, AS103.5 “Density”, AS104.4.5 “Gypsum plaster”, AS104.4.6 “Lime plaster”, AS104.4.8 “Cement plaster”, AS105.2 “Building limitations and requirements for use of strawbale nonstructural walls”, AS105.4 “Out-of-plane resistance methods and unrestrained wall dimension limits”, AS105.4.1 “Determination of out-of-plane loading”, AS105.4.2 “Pins”, AS105.6.4 “Horizontal surfaces”, AS105.6.8 “Separation of wood and plaster”, AS106.11 “Transfer of loads to and from plaster skins”, AS106.12 “Load-bearing walls”, AS106.13 “Braced wall panels”, AS106.13.1 “Bale wall thickness”. Modifies Table AS105.4 “OUT-OF-PLANE RESISTANCE METHODS AND UNRESTRAINED WALL DIMENSION	Same as change between 2015 IRC-B and 2018 IRC-B Update Appendix S										

Rule 61G20-2.002 2. Technical amendments needed to accommodate the specific needs of this state include but are not limited to amendments to the Florida Building Code that provide for the following: a. Establish minimum life safety construction requirements to protect buildings and their occupants from fire, wind, flood, and storm surge using the latest technical research and engineering standards for buildings and materials products. b. Provide for flood protection provisions that are consistent with the latest flood protection requirements of the National Flood Insurance Program. c. Maintain eligibility for federal funding and discounts from the National Flood Insurance Program, the Federal Emergency Management Agency, and the United States Department of Housing and Urban Development. d. Provide for energy efficiency standards for buildings that meet or exceed the national energy standards as mandated by Title III of the Energy Conservation and Protection Act. e. Maintain coordination with the Florida Fire Prevention Code. f. Provide for the latest industry standards and design

	AS106.11, AS106.12, AS106.13, AS106.13.1, AS106.5	<p>LIMITS”, TABLE AS106.13 (2) “BRACING REQUIREMENTS FOR STRAWBALE BRACED WALL PANELS BASED ON WIND SPEED”, TABLE AS106.13 (3) “BRACING REQUIREMENTS FOR STRAWBALE BRACED WALL PANELS BASED ON SEISMIC DESIGN CATEGORY”. Deletes AS106.5 Voids and stuffing.</p> <p>The proposal is to simplify or clarify ambiguous language. Also to correct typographical errors, errata, and changes to referenced section numbers in the IRC that changed from the 2012 to the 2015 IRC, but were not identified in Appendix S in the process of publishing the 2015 IRC. And change "basic wind speed" to "ultimate design wind speed" terminology and wind speeds in Tables AS105.4 and AS106.13(2), and update associated braced wall panel lengths in Table AS106.13(2).</p> <p>Cost Impact: Will not increase the cost of construction. The proposed changes in this proposal address matters of ambiguous language and corrections of errata. Therefore they have no cost impact.</p>			
<p>RCCIWG – Comment</p> <p>Impactful (Explain) <input type="checkbox"/></p>	<p>TAC Action</p> <p>Accommodate Florida Specific Need: YES (Select Criteria) <input type="checkbox"/> NO: <input type="checkbox"/> a. <input type="checkbox"/> b. <input type="checkbox"/> c. <input type="checkbox"/> d. <input type="checkbox"/> e. <input type="checkbox"/> f. <input type="checkbox"/> Others (Explain):</p>	<p>Commission Action</p> <p>Accommodate Florida Specific Need: YES (Select Criteria) <input type="checkbox"/> NO: <input type="checkbox"/> a. <input type="checkbox"/> b. <input type="checkbox"/> c. <input type="checkbox"/> d. <input type="checkbox"/> e. <input type="checkbox"/> f. <input type="checkbox"/> Others (Explain):</p>	<p><input type="checkbox"/> No Action Needed</p> <p><input type="checkbox"/> Overlapping provisions</p>	<p>TAC</p> <p><input type="checkbox"/></p> <p><input type="checkbox"/></p>	<p>Commission</p> <p><input type="checkbox"/></p> <p><input type="checkbox"/></p>
RB367-16	AS101.2 (New), AS102.1, AS103.2, AS103.2 (New), AS105.1, AS105.1(1) (New), AS105.1(2) (New), AS105.1(3)	Modifies text of Section AS101.2 “Strawbale wall systems”, AS103.2 “Size”, AS105.1 “General”, AS105.3 “Sill plates”, AS106.3 “Foundations”, AS106.10 “Support of plaster skins”, AS106.11 “Transfer of loads to and from plaster skins”. Modifies FIGURE AS103.2 “APPROXIMATE DIMENSIONS OF COMMON STRAW BALES”, Figure AS101.2 “TYPICAL STRAWBALE WALL SYSTEMS”, FIGURE AS105.1(1) “TYPICAL BASE OF PLASTERED STRAWBALE WALL ON CONCRETE SLAB AND FOOTING”, FIGURE AS105.1(2) “TYPICAL BASE OF PLASTERED STRAWBALE WALL OVER RAISED FLOOR”, FIGURE AS105.1(3) “TYPICAL TOP OF LOAD-BEARING STRAWBALE WALL”, FIGURE AS105.1(4)	Same as change between 2015 IRC-B and 2018 IRC-B Update Appendix S		

Rule 61G20-2.002 2. Technical amendments needed to accommodate the specific needs of this state include but are not limited to amendments to the Florida Building Code that provide for the following: a. Establish minimum life safety construction requirements to protect buildings and their occupants from fire, wind, flood, and storm surge using the latest technical research and engineering standards for buildings and materials products. b. Provide for flood protection provisions that are consistent with the latest flood protection requirements of the National Flood Insurance Program. c. Maintain eligibility for federal funding and discounts from the National Flood Insurance Program, the Federal Emergency Management Agency, and the United States Department of Housing and Urban Development. d. Provide for energy efficiency standards for buildings that meet or exceed the national energy standards as mandated by Title III of the Energy Conservation and Protection Act. e. Maintain coordination with the Florida Fire Prevention Code. f. Provide for the latest industry standards and design

	<p>(New), AS105.1(4) (New), AS105.3, AS106.10, AS106.11, AS106.12.3 (New), AS106.12.3.1 (New), AS106.15 (New), AS106.3</p>	<p>"TYPICAL TOP OF POST-AND-BEAM WALL WITH PLASTERED STRAW BALE INFILL". Adds new Section AS106.12.3 "Roof bearing assembly", AS106.12.3.1 "Roof bearing assembly spanning openings", AS106.15 "Post-and-beam with strawbale infill". Modifies Definition of AS102.1 Definitions, "LAID FLAT", "ON-EDGE". Adds definition "ON-END".</p> <p>This proposal brings seven Figures that illustrate strawbale wall systems and their components from the Commentary into Appendix S.</p> <p>Cost Impact: Will not increase the cost of construction.</p>			
<p>RCCIWG – Comment</p> <p>Impactful (Explain) <input type="checkbox"/></p>	<p>TAC Action</p> <p>Accommodate Florida Specific Need:</p> <p>YES (Select Criteria) <input type="checkbox"/> NO: <input type="checkbox"/></p> <p>a. <input type="checkbox"/> b. <input type="checkbox"/> c. <input type="checkbox"/> d. <input type="checkbox"/> e. <input type="checkbox"/> f. <input type="checkbox"/></p> <p>Others (Explain):</p>	<p>Commission Action</p> <p>Accommodate Florida Specific Need:</p> <p>YES (Select Criteria) <input type="checkbox"/> NO: <input type="checkbox"/></p> <p>a. <input type="checkbox"/> b. <input type="checkbox"/> c. <input type="checkbox"/> d. <input type="checkbox"/> e. <input type="checkbox"/> f. <input type="checkbox"/></p> <p>Others (Explain):</p>	<p><input type="checkbox"/> No Action Needed</p> <p><input type="checkbox"/> Overlapping provisions</p>	<p>TAC</p> <p><input type="checkbox"/></p> <p><input type="checkbox"/></p>	<p>Commission</p> <p><input type="checkbox"/></p> <p><input type="checkbox"/></p>
<p>RB368-16</p>	<p>AS102.1, AS104.2, AS104.4.3.1, AS104.4.3.2, AS104.4.4.1, AS105.3.1 (New), AS105.4, AS105.6, AS105.6.9 (New), AS106.1, AS106.12.3 (New), AS106.12.3.1 (New), AS106.12.5 (New),</p>	<p>Modifies definitions of Section AS102.1 Definition, "CLAY SLIP". Adds definition "CLAY SUBSOIL" and "ON-END". Modifies text of Section AS104.2 "Purpose, and where required", AS104.4.3.1 "General", AS104.4.3.2 "Clay subsoil requirements", AS104.4.4.1 "General", AS105.6 "Moisture control", AS106.1 "General", AS108.1 "R-value". Modifies Table AS105.4 "OUT-OF-PLANE RESISTANCE METHODS AND UNRESTRAINED WALL DIMENSION LIMITS". Adds new Section AS105.3.1 "Exterior sill plate flashing", AS105.6.9 "Separation of exterior plaster and foundation", AS106.2 "Building limitations and requirements for use of strawbale structural walls", AS106.12.3 "Roof bearing assembly", AS106.12.3.1 "Roof bearing assembly spanning openings", AS106.12.5 "Post-and-beam with strawbale infill", AS108.2 "Compliance with Section R302.10.1". Adds new standard to AS109 "reference standards", E2392/E2392M-10 "Standard Guide for Design of Earthen Wall Building Systems".</p>	<p>Same as change between 2015 IRC-B and 2018 IRC-B</p> <p>Update Appendix S</p>		

Rule 61G20-2.002 2. Technical amendments needed to accommodate the specific needs of this state include but are not limited to amendments to the Florida Building Code that provide for the following:

a. Establish minimum life safety construction requirements to protect buildings and their occupants from fire, wind, flood, and storm surge using the latest technical research and engineering standards for buildings and materials products.

b. Provide for flood protection provisions that are consistent with the latest flood protection requirements of the National Flood Insurance Program.

c. Maintain eligibility for federal funding and discounts from the National Flood Insurance Program, the Federal Emergency Management Agency, and the United States Department of Housing and Urban Development.

d. Provide for energy efficiency standards for buildings that meet or exceed the national energy standards as mandated by Title III of the Energy Conservation and Protection Act.

e. Maintain coordination with the Florida Fire Prevention Code.

f. Provide for the latest industry standards and design

	AS106.2 (New), AS108.1, AS108.2 (New), AS109	The proposed code changes in this proposal create new or revised requirements relative to the appendix as first approved for the 2015 IRC. These changes are based on further experience and additional input from prominent straw bale construction design and building professionals in different regions of the United States. Cost Impact: Will not increase the cost of construction. The proposed code changes in this proposal are minor relative to the overall system of strawbale construction and therefore will have no cost impact when using this method of construction.		
--	--	---	--	--

RCCIWG – Comment	TAC Action	Commission Action		TAC	Commission
Impactful (Explain) <input type="checkbox"/>	Accommodate Florida Specific Need: YES (Select Criteria) <input type="checkbox"/> NO: <input type="checkbox"/> a. <input type="checkbox"/> b. <input type="checkbox"/> c. <input type="checkbox"/> d. <input type="checkbox"/> e. <input type="checkbox"/> f. <input type="checkbox"/> Others (Explain): _____	Accommodate Florida Specific Need: YES (Select Criteria) <input type="checkbox"/> NO: <input type="checkbox"/> a. <input type="checkbox"/> b. <input type="checkbox"/> c. <input type="checkbox"/> d. <input type="checkbox"/> e. <input type="checkbox"/> f. <input type="checkbox"/> Others (Explain): _____	<input type="checkbox"/> No Action Needed <input type="checkbox"/> Overlapping provisions	<input type="checkbox"/> <input type="checkbox"/>	<input type="checkbox"/> <input type="checkbox"/>

RB376-16	R703.8.4	Modifies text of table R703.8.4 “TIE ATTACHMENT AND AIRSPACE REQUIREMENTS”. This clarification to the code is proposed to acknowledge that the airspace may contain some mortar from construction as long as it provides drainage. Cost Impact: Will not increase the cost of construction. This code change proposal is a clarification of the existing code language. It is intended to acknowledge and reflect more closely the common practice used in the field for the construction of anchored stone and masonry veneer construction. As such, there should be no cost impact.	Same as change between 2015 IRC-B and 2018 IRC-B	
----------	----------	--	--	--

RCCIWG – Comment	TAC Action	Commission Action		TAC	Commission
Impactful (Explain) <input type="checkbox"/>	Accommodate Florida Specific Need: YES (Select Criteria) <input type="checkbox"/> NO: <input type="checkbox"/> a. <input type="checkbox"/> b. <input type="checkbox"/> c. <input type="checkbox"/> d. <input type="checkbox"/> e. <input type="checkbox"/> f. <input type="checkbox"/> Others (Explain): _____	Accommodate Florida Specific Need: YES (Select Criteria) <input type="checkbox"/> NO: <input type="checkbox"/> a. <input type="checkbox"/> b. <input type="checkbox"/> c. <input type="checkbox"/> d. <input type="checkbox"/> e. <input type="checkbox"/> f. <input type="checkbox"/> Others (Explain): _____	<input type="checkbox"/> No Action Needed <input type="checkbox"/> Overlapping provisions	<input type="checkbox"/> <input type="checkbox"/>	<input type="checkbox"/> <input type="checkbox"/>

Rule 61G20-2.002 2. Technical amendments needed to accommodate the specific needs of this state include but are not limited to amendments to the Florida Building Code that provide for the following:

- a. Establish minimum life safety construction requirements to protect buildings and their occupants from fire, wind, flood, and storm surge using the latest technical research and engineering standards for buildings and materials products.
- b. Provide for flood protection provisions that are consistent with the latest flood protection requirements of the National Flood Insurance Program.
- c. Maintain eligibility for federal funding and discounts from the National Flood Insurance Program, the Federal Emergency Management Agency, and the United States Department of Housing and Urban Development.
- d. Provide for energy efficiency standards for buildings that meet or exceed the national energy standards as mandated by Title III of the Energy Conservation and Protection Act.
- e. Maintain coordination with the Florida Fire Prevention Code.
- f. Provide for the latest industry standards and design

<p>G10-16 Part IV</p>	<p>R202</p>	<p>Revises section R202 definition “Skylights and sloped glazing” to clarify which products fall under the “skylight” category.</p> <p>Cost Impact: Will not increase the cost of construction. The proposal simply clarifies which products fall under the category of "skylight", and by default, which do not. It will not impact the cost of construction</p>	<p>Same as change between 2015 IBC and 2018 IBC</p>			
<p>RCCIWG – Comment</p> <p>Impactful (Explain) <input type="checkbox"/></p>		<p>TAC Action</p> <p>Accommodate Florida Specific Need: YES (Select Criteria) <input type="checkbox"/> NO: <input type="checkbox"/></p> <p>a. <input type="checkbox"/> b. <input type="checkbox"/> c. <input type="checkbox"/> d. <input type="checkbox"/> e. <input type="checkbox"/> f. <input type="checkbox"/></p> <p>Others (Explain):</p>	<p>Commission Action</p> <p>Accommodate Florida Specific Need: YES (Select Criteria) <input type="checkbox"/> NO: <input type="checkbox"/></p> <p>a. <input type="checkbox"/> b. <input type="checkbox"/> c. <input type="checkbox"/> d. <input type="checkbox"/> e. <input type="checkbox"/> f. <input type="checkbox"/></p> <p>Others (Explain):</p>	<p><input type="checkbox"/> No Action Needed</p> <p><input type="checkbox"/> Overlapping provisions</p>	<p>TAC</p> <p><input type="checkbox"/></p> <p><input type="checkbox"/></p>	<p>Commission</p> <p><input type="checkbox"/></p> <p><input type="checkbox"/></p>

Rule 61G20-2.002 2. Technical amendments needed to accommodate the specific needs of this state include but are not limited to amendments to the Florida Building Code that provide for the following:

a. Establish minimum life safety construction requirements to protect buildings and their occupants from fire, wind, flood, and storm surge using the latest technical research and engineering standards for buildings and materials products. b. Provide for flood protection provisions that are consistent with the latest flood protection requirements of the National Flood Insurance Program. c. Maintain eligibility for federal funding and discounts from the National Flood Insurance Program, the Federal Emergency Management Agency, and the United States Department of Housing and Urban Development. d. Provide for energy efficiency standards for buildings that meet or exceed the national energy standards as mandated by Title III of the Energy Conservation and Protection Act. e. Maintain coordination with the Florida Fire Prevention Code. f. Provide for the latest industry standards and design

Code Change No: **RB2-16**

Original Proposal

Section: R202, M1305.1, M1407.4, M1503.4, M1601.1.2, M1601.4.1, M1803.3.5, M1803.4.3, M2204.2, M2301.2.1, R1001.2.1, R1003.9.2, R202, R202 (New), R301.5, R302.7, R308.4.3, R308.4.6, R308.6.2, R308.6.5, R310.5, R311.3, R807.1

Proponent: David Collins (dcollins@preview-group.com); Dan Buuck (dbuuck@nahb.org); Steven Orłowski (sorłowski@boma.org)

Delete and substitute as follows:

~~**ACCESSIBLE.** Signifies access that requires the removal of an access panel or similar removable obstruction.~~

~~**ACCESS (TO)** That which enables a device, appliance or equipment to be reached by *ready access* or by a means that first requires the removal or movement of a panel, door or similar obstruction.~~

~~**ACCESSIBLE, READILY.** Signifies access without the necessity for removing a panel or similar obstruction.~~

~~**READY ACCESS (TO)** That which enables a device, appliance or equipment to be directly reached, without requiring the removal or movement of any panel, door or similar obstruction.~~

Revise as follows:

~~**CLEANOUT.** An *accessible* opening in the drainage system used for the removal of possible obstruction and located to allow for *access*.~~

FIXTURE FITTING.

Supply fitting. A fitting that controls the volume or directional flow or both of water and that is either attached to or ~~accessible~~ is *accessed* from a fixture or is used with an open or atmospheric discharge.

Waste fitting. A combination of components that conveys the sanitary waste from the outlet of a fixture to the connection of the sanitary drainage system.

TABLE R301.5
MINIMUM UNIFORMLY DISTRIBUTED LIVE LOADS (in pounds per square foot)

USE	LIVE LOAD
Uninhabitable attics without storage ^b	10
Uninhabitable attics with limited storage ^{b,g}	20
Habitable attics and attics served with fixed stairs	30
Balconies (exterior) and decks ^e	40
Fire escapes	40
Guards and handrails ^d	200 ^h
Guard in-fill components ^f	50 ^h
Passenger vehicle garages ^a	50 ^a
Rooms other than sleeping rooms	40
Sleeping rooms	30
Stairs	40 ^c

For SI: 1 pound per square foot = 0.0479 kPa, 1 square inch = 645 mm², 1 pound = 4.45 N.

- a. Elevated garage floors shall be capable of supporting a 2,000-pound load applied over a 20-square-inch area.
- b. Uninhabitable *attics* without storage are those where the clear height between joists and rafters is not more than 42 inches, or where there are not two or more adjacent trusses with web configurations capable of accommodating an assumed rectangle 42 inches in height by 24 inches in width, or greater, within the plane of the trusses. This live load need not be assumed to act concurrently with any other live load requirements.
- c. Individual stair treads shall be designed for the uniformly distributed live load or a 300-pound concentrated load acting over an area of 4 square inches, whichever produces the greater stresses.
- d. A single concentrated load applied in any direction at any point along the top.
- e. See Section R507.1 for decks attached to *exterior walls*.
- f. *Guard* in-fill components (all those except the handrail), balusters and panel fillers shall be designed to withstand a horizontally applied normal load of 50 pounds on an area equal to 1 square foot. This load need not be assumed to act concurrently with any other live load requirement.
- g. Uninhabitable *attics* with limited storage are those where the clear height between joists and rafters is not greater than 42 inches, or where there are two or more adjacent trusses with web configurations capable of accommodating an assumed rectangle 42 inches in height by 24 inches in width, or greater, within the plane of the trusses. The live load need only be applied to those portions of the joists or truss bottom chords where all of the following conditions are met:
 1. The *attic* area is accessible accessed from an opening not less than 20 inches in width by 30 inches in length that is located where the clear height in the *attic* is not less than 30 inches.
 2. The slopes of the joists or truss bottom chords are not greater than 2 inches vertical to 12 units horizontal.
 3. Required insulation depth is less than the joist or truss bottom chord member depth.
 The remaining portions of the joists or truss bottom chords shall be designed for a uniformly distributed concurrent live load of not less than 10 pounds per square foot.
- h. Glazing used in handrail assemblies and *guards* shall be designed with a safety factor of 4. The safety factor shall be applied to each of the concentrated loads applied to the top of the rail, and to the load on the in-fill components. These loads shall be determined independent of one another, and loads are assumed not to occur with any other live load.

R302.7 Under-stair protection. Enclosed ~~accessible~~ space under stairs that is accessed by a door or access panel, shall have walls, under-stair surface and any soffits protected on the enclosed side with ¹/₂-inch (12.7 mm) gypsum board.

R308.4.3 Glazing in windows. Glazing in an individual fixed or operable panel that meets all of the following conditions shall be considered to be a hazardous location:

1. The exposed area of an individual pane is larger than 9 square feet (0.836 m²),
2. The bottom edge of the glazing is less than 18 inches (457 mm) above the floor,
3. The top edge of the glazing is more than 36 inches (914 mm) above the floor; and
4. One or more walking surfaces are within 36 inches (914 mm), measured horizontally and in a straight line, of the glazing.

Exceptions:

1. Decorative glazing.
2. Where glazing is adjacent to a walking surface and a horizontal rail is installed on the accessible side(s) of the glazing 34 to 38 inches (864 to 965 mm) above the walking surface. The rail shall be capable of withstanding a horizontal load of 50 pounds per linear foot (730 N/m) without contacting the glass and have a cross-sectional height of not less than 1¹/₂ inches (38 mm).
3. Outboard panes in insulating glass units and other multiple glazed panels where the bottom edge of the glass is 25 feet (7620 mm) or more above *grade*, a roof, walking surfaces or other horizontal [within 45 degrees (0.79 rad) of horizontal] surface adjacent to the glass exterior.

R308.4.6 Glazing adjacent to stairs and ramps. Glazing where the bottom exposed edge of the glazing is less than 36 inches (914 mm) above the plane of the adjacent walking surface of stairways, landings between flights of stairs and ramps shall be considered to be a hazardous location.

Exceptions:

1. Where glazing is adjacent to a walking surface and a horizontal rail is installed on the accessible side(s) of the glazing at 34 to 38 inches (864 to 965 mm) above the walking

- surface. The rail shall be capable of withstanding a horizontal load of 50 pounds per linear foot (730 N/m) without contacting the glass and have a cross-sectional height of not less than 1 1/2 inches (38 mm).
2. Glazing 36 inches (914 mm) or more measured horizontally from the walking surface.

R308.6.2 Materials. The following types of glazing shall be permitted to be used:

1. Laminated glass with not less than a 0.015-inch (0.38 mm) polyvinyl butyral interlayer for glass panes 16 square feet (1.5 m²) or less in area located such that the highest point of the glass is not more than 12 feet (3658 mm) above a walking surface ~~or other accessible area~~; for higher or larger sizes, the interlayer thickness shall be not less than 0.030 inch (0.76 mm).
2. Fully tempered glass.
3. Heat-strengthened glass.
4. Wired glass.
5. *Approved rigid plastics.*

R308.6.5 Screens not required. Screens shall not be required where fully tempered glass is used as single glazing or the inboard pane in multiple glazing and either of the following conditions are met:

1. Glass area 16 square feet (1.49 m²) or less. Highest point of glass not more than 12 feet (3658 mm) above a walking surface ~~or other accessible area~~, nominal glass thickness not more than 3/16 inch (4.8 mm), and (for multiple glazing only) the other pane or panes fully tempered, laminated or wired glass.
2. Glass area greater than 16 square feet (1.49 m²). Glass sloped 30 degrees (0.52 rad) or less from vertical, and highest point of glass not more than 10 feet (3048 mm) above a walking surface ~~or other accessible area~~.

R310.5 Dwelling additions. Where *dwelling additions* occur that contain sleeping rooms, an emergency escape and rescue opening shall be provided in each new sleeping room. Where *dwelling additions* occur that have *basements*, an emergency escape and rescue opening shall be provided in the new *basement*.

Exceptions:

1. An emergency escape and rescue opening is not required in a new *basement* that contains a sleeping room with an emergency escape and rescue opening.
2. An emergency escape and rescue opening is not required in a new *basement* where there is an emergency escape and rescue opening in an existing *basement* that is accessible accessed from the new *basement*.

R311.3 Floors and landings at exterior doors. There shall be a landing or floor on each side of each exterior door. The width of each landing shall be not less than the door served. Every landing shall have a dimension of not less than 36 inches (914 mm) measured in the direction of travel. The slope at exterior landings shall not exceed 1/4 unit vertical in 12 units horizontal (2 percent).

Exception: Exterior balconies less than 60 square feet (5.6 m²) and only accessible accessed from a door are permitted to have a landing less than 36 inches (914 mm) measured in the direction of travel.

R807.1 Attic access. Buildings with combustible ceiling or roof construction shall have an *attic* access opening to *attic* areas that have a vertical height of 30 inches (762 mm) or greater over an area of not less than 30 square feet (2.8 m²). The vertical height shall be measured from the top of the ceiling framing members to the underside of the roof framing members.

The rough-framed opening shall be not less than 22 inches by 30 inches (559 mm by 762 mm) and shall be located in a hallway or other ~~readily accessible~~ location with ready access. Where located in a wall, the opening shall be not less than 22 inches wide by 30 inches high (559 mm wide by 762 mm high). Where the access is located in a ceiling, minimum unobstructed headroom in the *attic* space shall be 30

inches (762 mm) at some point above the access measured vertically from the bottom of ceiling framing members. See Section M1305.1.3 for access requirements where mechanical *equipment* is located in *attics*.

R1001.2.1 Ash dump cleanout. Cleanout openings located within foundation walls below fireboxes, when provided, shall be equipped with ferrous metal or masonry doors and frames constructed to remain tightly closed except when in use. Cleanouts shall be ~~accessible~~located to allow access and ~~located~~ so that ash removal will not create a hazard to combustible materials.

R1003.9.2 Spark arrestors. Where a spark arrestor is installed on a masonry chimney, the spark arrestor shall meet all of the following requirements:

1. The net free area of the arrestor shall be not less than four times the net free area of the outlet of the chimney flue it serves.
2. The arrestor screen shall have heat and corrosion resistance equivalent to 19-gage galvanized steel or 24-gage stainless steel.
3. Openings shall not permit the passage of spheres having a diameter greater than $1\frac{1}{2}$ inch (12.7 mm) nor block the passage of spheres having a diameter less than $\frac{3}{8}$ inch (9.5 mm).
4. The spark arrestor shall be ~~accessible~~located with access for cleaning and the screen or chimney cap shall be removable to allow for cleaning of the chimney flue.

M1305.1 Appliance access for inspection service, repair and replacement. *Appliances* shall be ~~accessible~~located to allow for access for inspection, service, repair and replacement without removing permanent construction, other *appliances*, or any other piping or ducts not connected to the *appliance* being inspected, serviced, repaired or replaced. A level working space not less than 30 inches deep and 30 inches wide (762 mm by 762 mm) shall be provided in front of the control side to service an *appliance*.

M1407.4 Access. Duct heaters shall be ~~accessible~~located to allow access for servicing, and clearance shall be maintained to permit adjustment, servicing and replacement of controls and heating elements.

M1503.4 Makeup air required. Exhaust hood systems capable of exhausting in excess of 400 cubic feet per minute (0.19 m³/s) shall be mechanically or naturally provided with makeup air at a rate approximately equal to the exhaust air rate. Such makeup air systems shall be equipped with not less than one damper. Each damper shall be a gravity damper or an electrically operated damper that automatically opens when the exhaust system operates. Dampers shall be ~~accessible~~located to allow access for inspection, service, repair and replacement without removing permanent construction or any other ducts not connected to the damper being inspected, serviced, repaired or replaced.

M1601.1.2 Underground duct systems. Underground *duct systems* shall be constructed of *approved* concrete, clay, metal or plastic. The maximum duct temperature for plastic ducts shall not be greater than 150°F (66°C). Metal ducts shall be protected from corrosion in an *approved* manner or shall be completely encased in concrete not less than 2 inches (51 mm) thick. Nonmetallic ducts shall be installed in accordance with the manufacturer's instructions. Plastic pipe and fitting materials shall conform to cell classification 12454-B of ASTM D 1248 or ASTM D 1784 and external loading properties of ASTM D 2412. Ducts shall slope to ~~an accessible~~a point for drainage that has access. Where encased in concrete, ducts shall be sealed and secured prior to any concrete being poured. Metallic ducts having an *approved* protective coating and nonmetallic ducts shall be installed in accordance with the manufacturer's instructions.

M1601.4.1 Joints, seams and connections. Longitudinal and transverse joints, seams and connections in metallic and nonmetallic ducts shall be constructed as specified in SMACNA HVAC *Duct Construction Standards—Metal and Flexible* and NAIMA *Fibrous Glass Duct Construction Standards*. Joints, longitudinal and transverse seams, and connections in ductwork shall be securely fastened and sealed with welds, gaskets, mastics (adhesives), mastic-plus-embedded-fabric systems, liquid sealants or tapes. Tapes and mastics used to seal fibrous glass ductwork shall be *listed* and *labeled* in accordance with UL

181A and shall be marked "181A-P" for pressure-sensitive tape, "181 A-M" for mastic or "181 A-H" for heat-sensitive tape.

Tapes and mastics used to seal metallic and flexible air ducts and flexible air connectors shall comply with UL 181B and shall be marked "181 B-FX" for pressure-sensitive tape or "181 BM" for mastic. Duct connections to flanges of air distribution system equipment shall be sealed and mechanically fastened. Mechanical fasteners for use with flexible nonmetallic air ducts shall comply with UL 181B and shall be marked 181B-C. Crimp joints for round metallic ducts shall have a contact lap of not less than 1 inch (25 mm) and shall be mechanically fastened by means of not less than three sheet-metal screws or rivets equally spaced around the joint.

Closure systems used to seal all ductwork shall be installed in accordance with the manufacturers' instructions.

Exceptions:

1. Spray polyurethane foam shall be permitted to be applied without additional joint seals.
2. Where a duct connection is made that is partially ~~inaccessible~~ without access, three screws or rivets shall be equally spaced on the exposed portion of the joint so as to prevent a hinge effect.
3. For ducts having a static pressure classification of less than 2 inches of water column (500 Pa), additional closure systems shall not be required for continuously welded joints and seams and locking-type joints and seams of other than the snap-lock and button-lock types.

M1803.3.5 Access. The entire length of a connector shall ~~be accessible~~ allow access for inspection, cleaning and replacement.

M1803.4.3 Connection to masonry fireplace flue. A connector shall extend from the *appliance* to the flue serving a masonry fireplace to convey the flue gases directly into the flue. The connector shall ~~be accessible~~ allow access or removable for inspection and cleaning of both the connector and the flue. *Listed* direct-connection devices shall be installed in accordance with their *listing*.

M2204.2 Shutoff valves. A ~~readily accessible~~ manual shutoff valve shall be installed to allow for ready access and be located between the oil supply tank and the burner. Where the shutoff valve is installed in the discharge line of an oil pump, a pressure-relief valve shall be incorporated to bypass or return surplus oil. Valves shall comply with UL 842.

M2301.2.1 Access. Solar energy collectors, controls, dampers, fans, blowers and pumps shall ~~be accessible~~ located to allow access for inspection, maintenance, repair and replacement.

Reason: The intent of this proposal is for clarification of terminology. This proposal will clarify where the provisions are for access for repair, not accessibility for persons with disabilities.

The term 'accessible' is defined in the IBC and relates to elements and facilities that serve or have special accommodations for persons with mobility impairments. This term is used that way in IRC Section R320 and R321.3. The IPC, IFGC and IMC use the defined term "Access (to)" or "Ready Access" for access to equipment. Using those terms are proposed here for the IRC where applicable.

The phrase "other accessible area" has been removed from Sections R308.4.6, R308.6.2 and R308.6.5. This is confusing and not uniformly enforceable.

There is a similar proposal for the IECC, including Chapter 11 of the IRC. A similar proposal was approved for the International Plumbing Code as part of Group A - P84-15.

Cost Impact: Will not increase the cost of construction

This is a clarification of terminology that will have no change on code requirements.

**Report of Committee Action
Hearings**

Committee Action:

Approved as Submitted

Committee Reason: This clarifies that code by separating something that is accessible from something that is accessed.

Assembly Action:

None

Final Action Results

RB2-16

AS

[←BACK](#)

[←BACK](#)

Code Change No: **RB6-16**

Original Proposal

Section: R202 (New)

Proponent: Richard Davidson, representing Self

Add new definition as follows:

CRAWL SPACE. An underfloor space that is not a basement.

Reason: There is no definition for "crawl space" yet the term is used forty four times in the code. Because definitions in Merriam-Webster are not appropriate to the use of the term in the IRC, it is necessary to create a definition that is appropriate and to distinguish those spaces from "basement".

For information: **BASEMENT.** A *story* that is not a story above grade plane. (see "Story above grade plane").

Cost Impact: Will not increase the cost of construction
This is an editorial revision that will have no impact on construction costs.

Report of Committee Action Hearings

Committee Action:

Approved as Submitted

Committee Reason: A crawlspace is something that is not a basement and this proposal makes that clear. Although the committee supports the proposal as submitted, grammatically, a first floor space under the second floor would meet the definition. The committee encourages the proponent to address this in the public comment period.

Assembly Action:

None

Final Action Results

RB6-16

AS

[←BACK](#)

Code Change No: RB17-16

Original Proposal

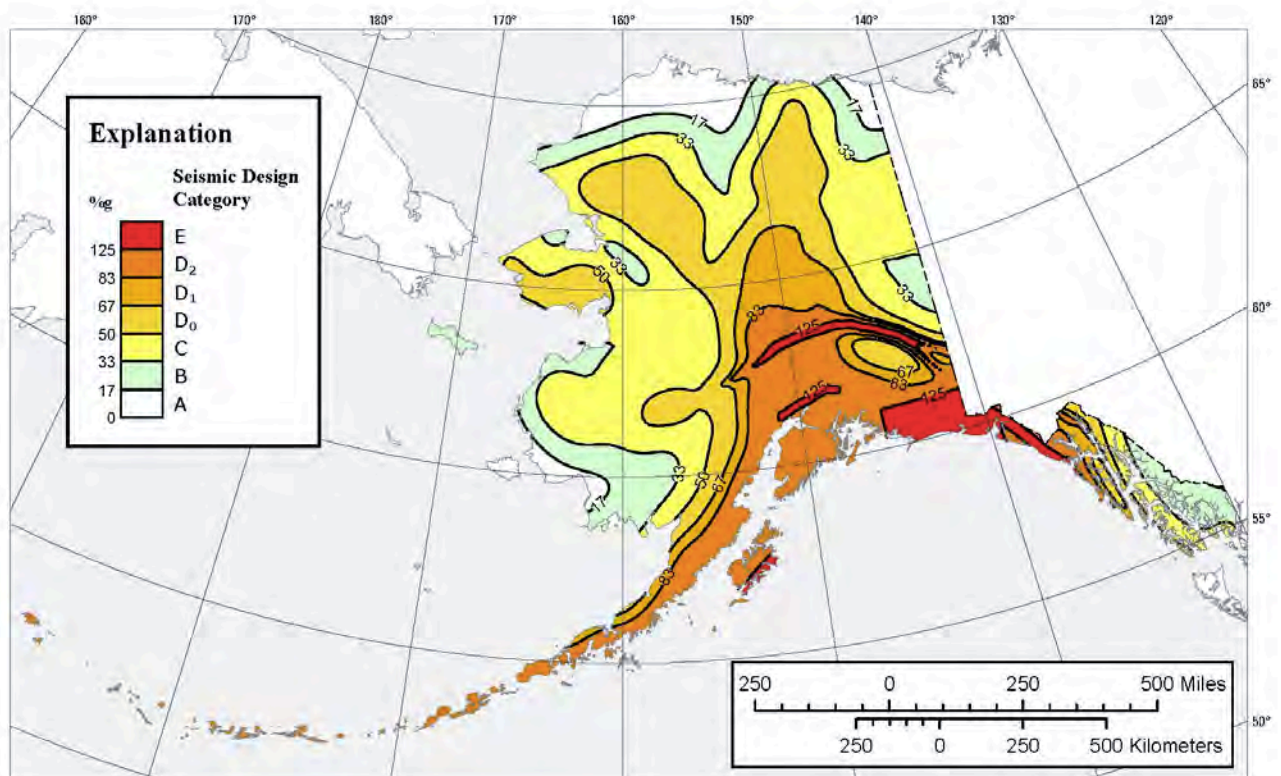
Section: R301.2, R301.2(3) (New), R301.2(3)-continued (New), R301.2.2.1.1, R301.2.2.1.2

Proponent: Kelly Cobeen, Wiss Janney Elstner Associates, Inc., representing Federal Emergency Management Agency and National Institute of Building Sciences Building Seismic Safety Council's Code Resource Support Committee (KCobeen@wje.com)

Delete and substitute as follows:

**FIGURE R301.2(2)
SEISMIC DESIGN CATEGORIES—SITE CLASS D**

(Existing code figure not shown for clarity)



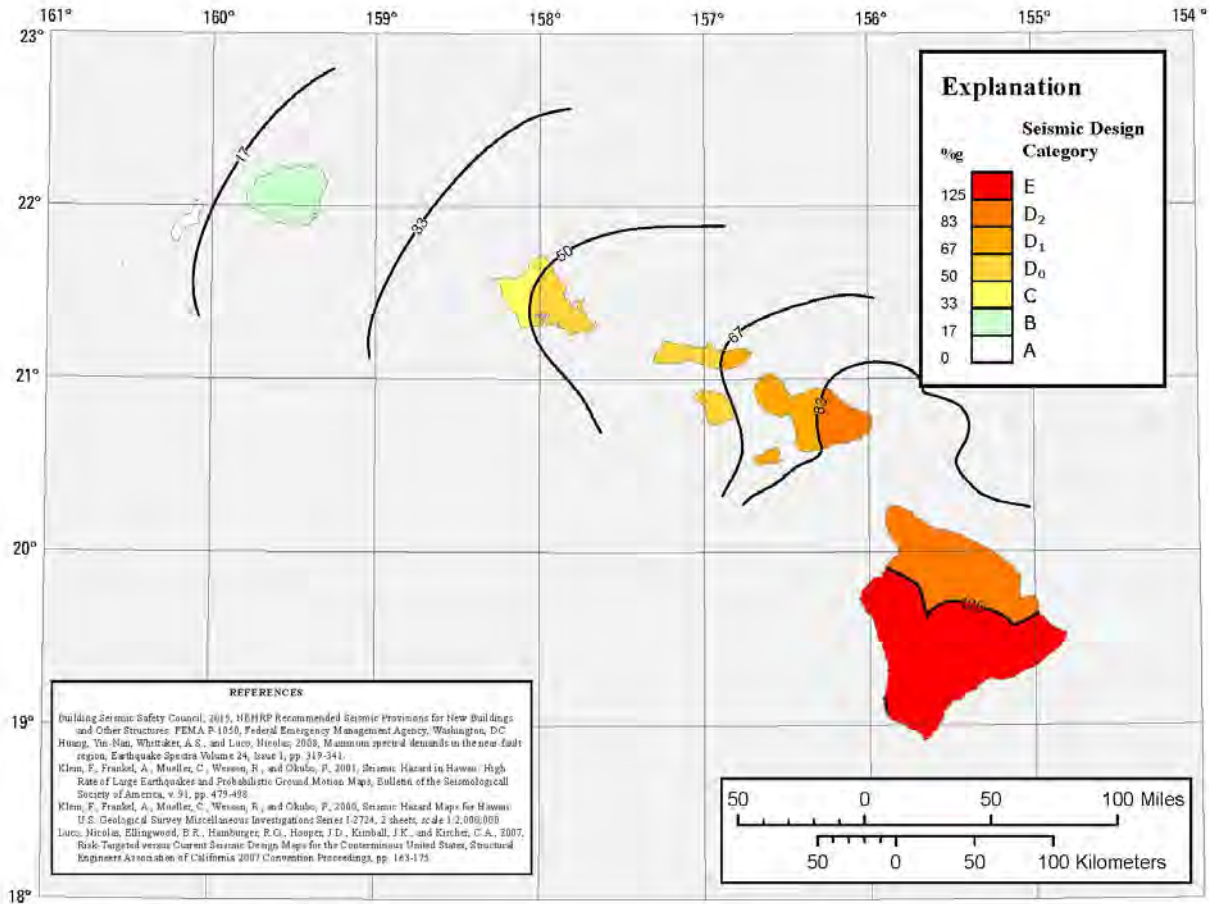
Map prepared by U.S. Geological Survey in collaboration with the Federal Emergency Management Agency (FEMA)-funded Building Seismic Safety Council's (BSSC) Code Resource Support Committee (CRSC)

REFERENCES
 Building Seismic Safety Council, 2015, NEHRP Recommended Seismic Provisions for New Buildings and Other Structures, FEMA P-1050, Federal Emergency Management Agency, Washington, DC.
 Huang, Yin-Nan, Whitaker, A. S., and Lusa, Nicolas, 2008, Maximum spectral demands in the near-fault region, Earthquake Spectra Volume 24, Issue 1, pp. 319-341.
 Lusa, Nicolas, Elingswood, B. R., Hamburger, R. O., Hooper, J. D., Kimball, J. K., and Kircher, C. A., 2007, Risk-Targeted versus Current Seismic Design Maps for the Conterminous United States, Structural Engineers Association of California 2007 Convention Proceedings, pp. 163-175.
 Wesson, Robert L., Boyd, Oliver S., Mueller, Charles S., Bufe, Charles O., Frankel, Arthur D., Petersen, Mark D., 2007, Revision of time-independent probabilistic seismic hazard maps for Alaska, U.S. Geological Survey Open-File Report 2007-1043.

**FIGURE R301.2(2) - continued
SEISMIC DESIGN CATEGORIES**

**FIGURE R301.2(2)-continued
SEISMIC DESIGN CATEGORIES—SITE CLASS-D**

(Existing code figure not shown for clarity)

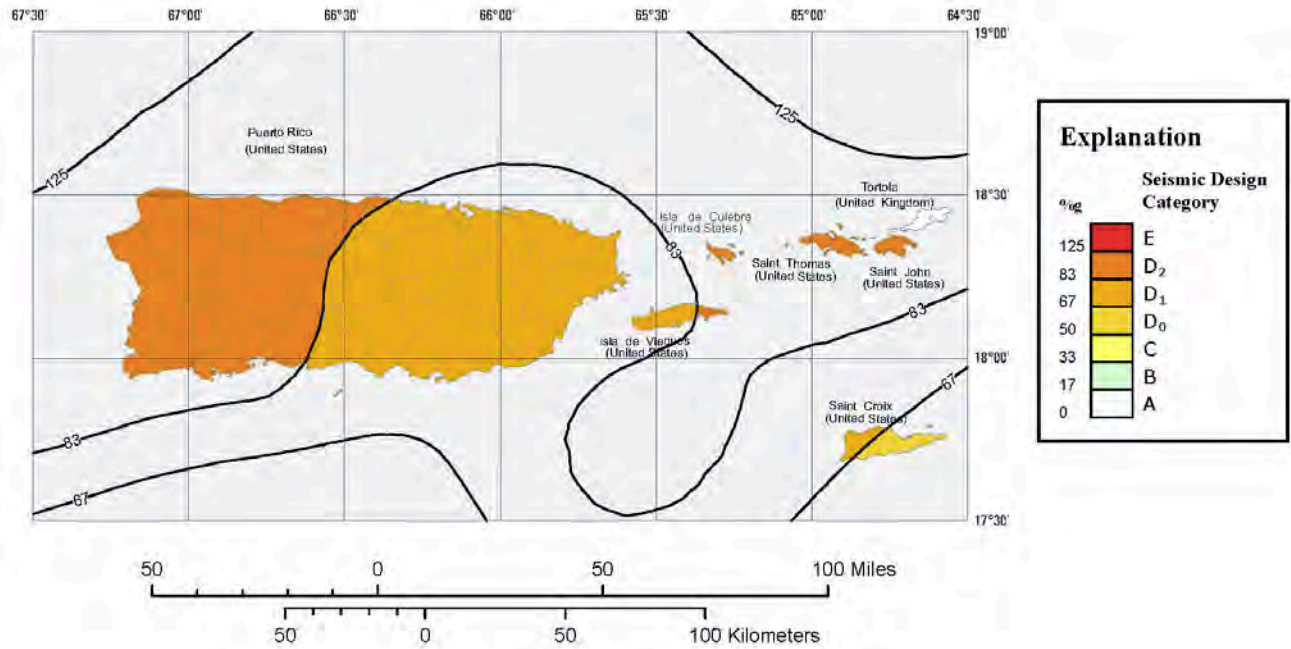


Map prepared by U.S. Geological Society in collaboration with the Federal Emergency Management Agency (FEMA), Sealed Building Seismic Safety Council's (BSSC) Code Resource Support Committee (CRSC)

**FIGURE R301.2(2) - continued
SEISMIC DESIGN CATEGORIES**

**FIGURE R301.2(2)-continued
SEISMIC DESIGN CATEGORIES—SITE CLASS-D**

(Existing code figure not shown for clarity)



REFERENCES

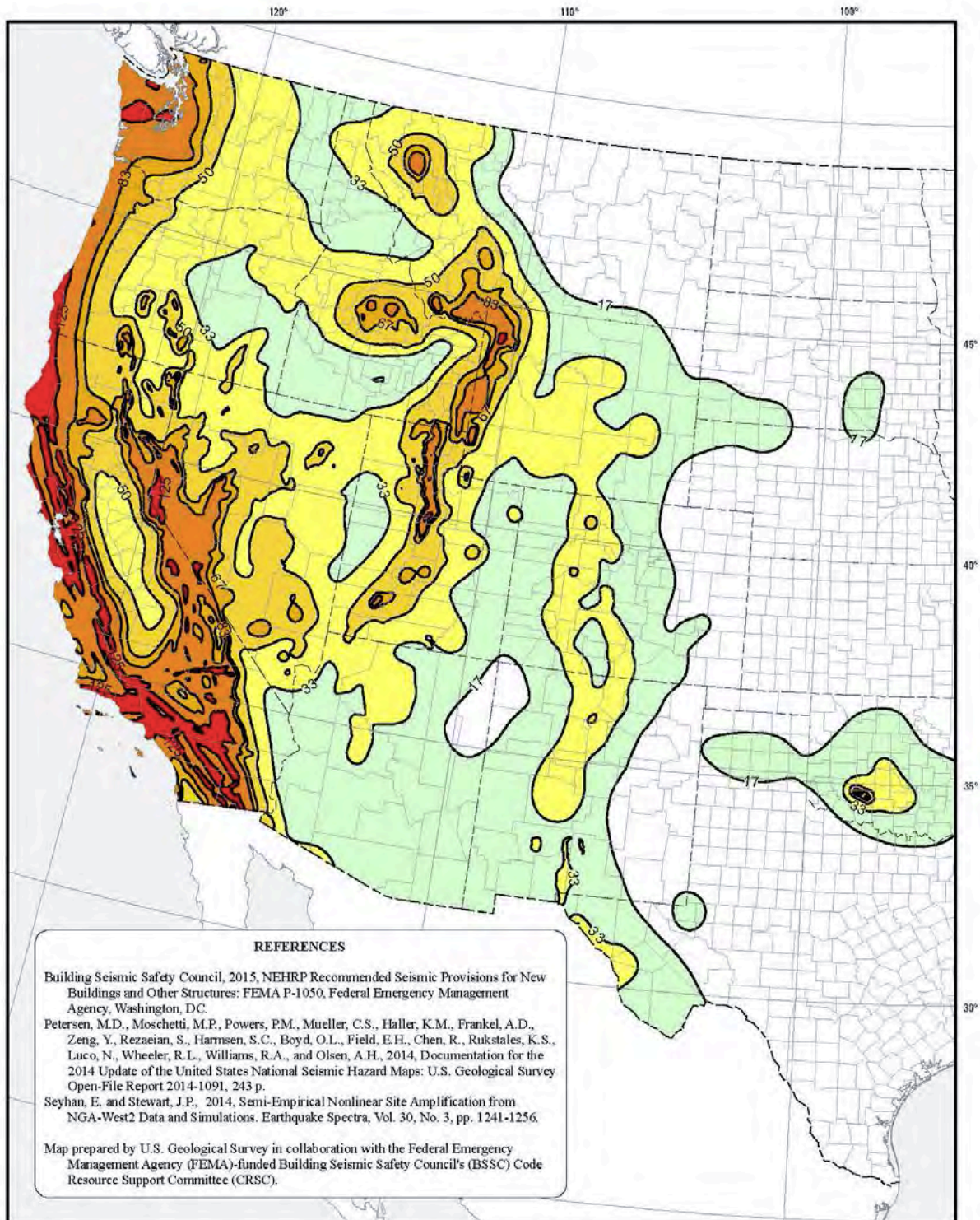
Building Seismic Safety Council, 2015, IBC/ASCE Recommended Seismic Provisions for New Buildings and Other Structures: FEMA P-1050, Federal Emergency Management Agency, Washington, DC
 Huang, Yin-Nan, Whittaker, A. S., and Luco, Nicolas, 2008, Maximum spectral demands in the near-fault region, Earthquake Spectra Volume 24, Issue 1, pp. 319-341.
 Luco, Nicolas, Ellingwood, B.R., Hamburger, E.C., Hooper, J.D., Kimball, J.K., and Krawiec, C.A., 2007, Risk-Targeted versus Current Seismic Design Maps for the Conterminous United States, Structural Engineers Association of California 2007 Convention Proceedings, pp. 163-175
 Mueller, C., Frankel, A., Petersen, M., and Leyendecker, E., 2003, Documentation for 2003 USGS Seismic Hazard Maps for Puerto Rico and the U.S. Virgin Islands, U.S. Geological Survey Open-File Report 03-175

Map prepared by U.S. Geological Survey in collaboration with the Federal Emergency Management Agency (FEMA)-funded Building Seismic Safety Council's (BSSC) Code Resource Support Committee (CRSC).

**FIGURE R301.2(2) - continued
SEISMIC DESIGN CATEGORIES**

**FIGURE R301.2(2)-continued
SEISMIC DESIGN CATEGORIES—SITE CLASS-D**

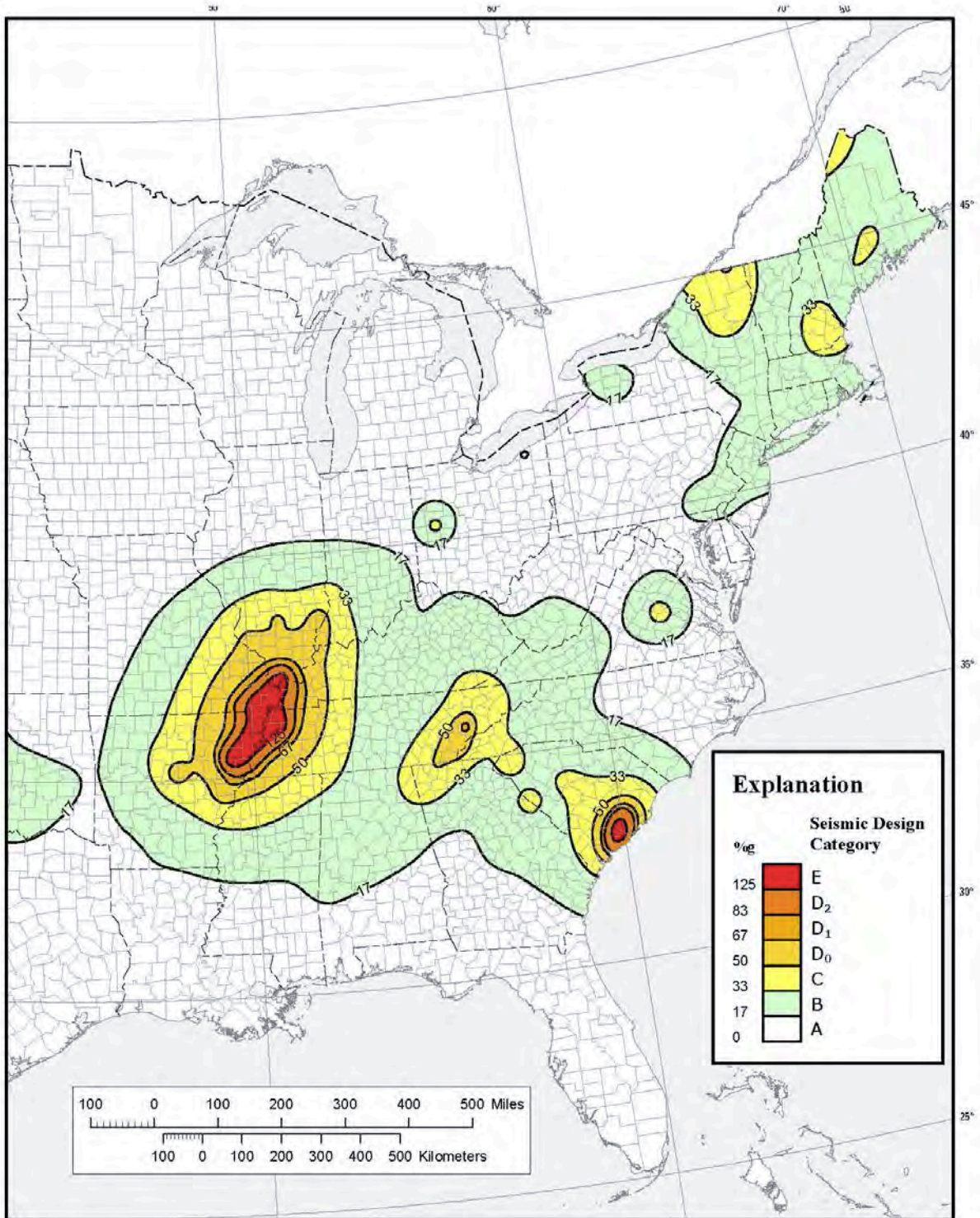
(Existing code figure not shown for clarity)



**FIGURE R301.2(2)
SEISMIC DESIGN CATEGORIES**

**FIGURE R301.2(2)-continued
SEISMIC DESIGN CATEGORIES—SITE CLASS-D**

(Existing code figure not shown for clarity)



**FIGURE R301.2(2) - continued
SEISMIC DESIGN CATEGORIES**

Revise as follows:

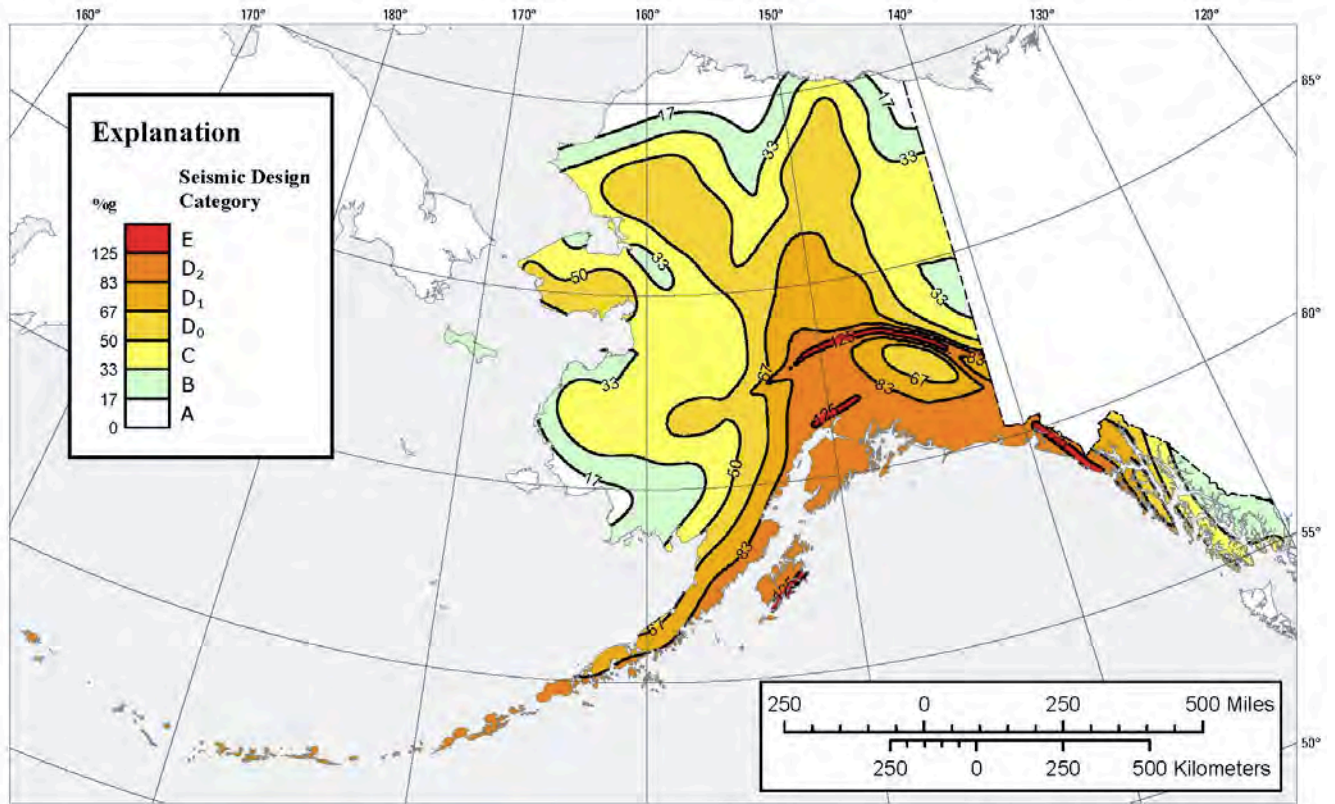
R301.2.2.1.1 Alternate determination of seismic design category. The seismic design categories and corresponding short-period design spectral response accelerations, S_{DS} , shown in Figure R301.2(2) are based on soil Site Class D, used as an assumed default, as defined in Section 1613.3.2 of the *International Building Code*. If soil conditions are ~~other than determined by the building official to be Site Class A, B, or D~~, the ~~short period seismic design category and short period design spectral response accelerations, S_{DS} , for a site can~~ shall be allowed to be determined in accordance with Figure R301.2(3) or Section 1613.3 of the International Building Code. The value of S_{DS} determined in accordance with Section 1613.3 of the International Building Code is permitted to be used to set the seismic design category in accordance with Table R301.2.2.1.1, and to interpolate between values in Tables R602.10.3(3), R603.9.2(1) and other seismic design requirements of this code.

R301.2.2.1.2 Alternative determination of Seismic Design Category E. Buildings located in Seismic Design Category E in accordance with Figure R301.2(2), or Figure R301.2(3) where applicable, are permitted to be reclassified as being in Seismic Design Category D_2 provided that one of the following is done:

1. A more detailed evaluation of the seismic design category is made in accordance with the provisions and maps of the *International Building Code*. Buildings located in Seismic Design Category E in accordance with Table R301.2.2.1.1, but located in Seismic Design Category D in accordance with the *International Building Code*, shall be permitted to be designed using the Seismic Design Category D_2 requirements of this code.
2. Buildings located in Seismic Design Category E that conform to the following additional restrictions are permitted to be constructed in accordance with the provisions for Seismic Design Category D_2 of this code:
 - 2.1. All exterior shear wall lines or *braced wall panels* are in one plane vertically from the foundation to the uppermost *story*.
 - 2.2. Floors shall not cantilever past the *exterior walls*.
 - 2.3. The building is within the requirements of Section R301.2.2.2.5 for being considered as regular.

Add new text as follows:

FIGURE R301.2(3)
Alternate Seismic Design Categories



Map prepared by U.S. Geological Survey in collaboration with the Federal Emergency Management Agency (FEMA), Building Seismic Safety Council's (BSSC) Code Resource Support Committee (CRSC).

REFERENCES

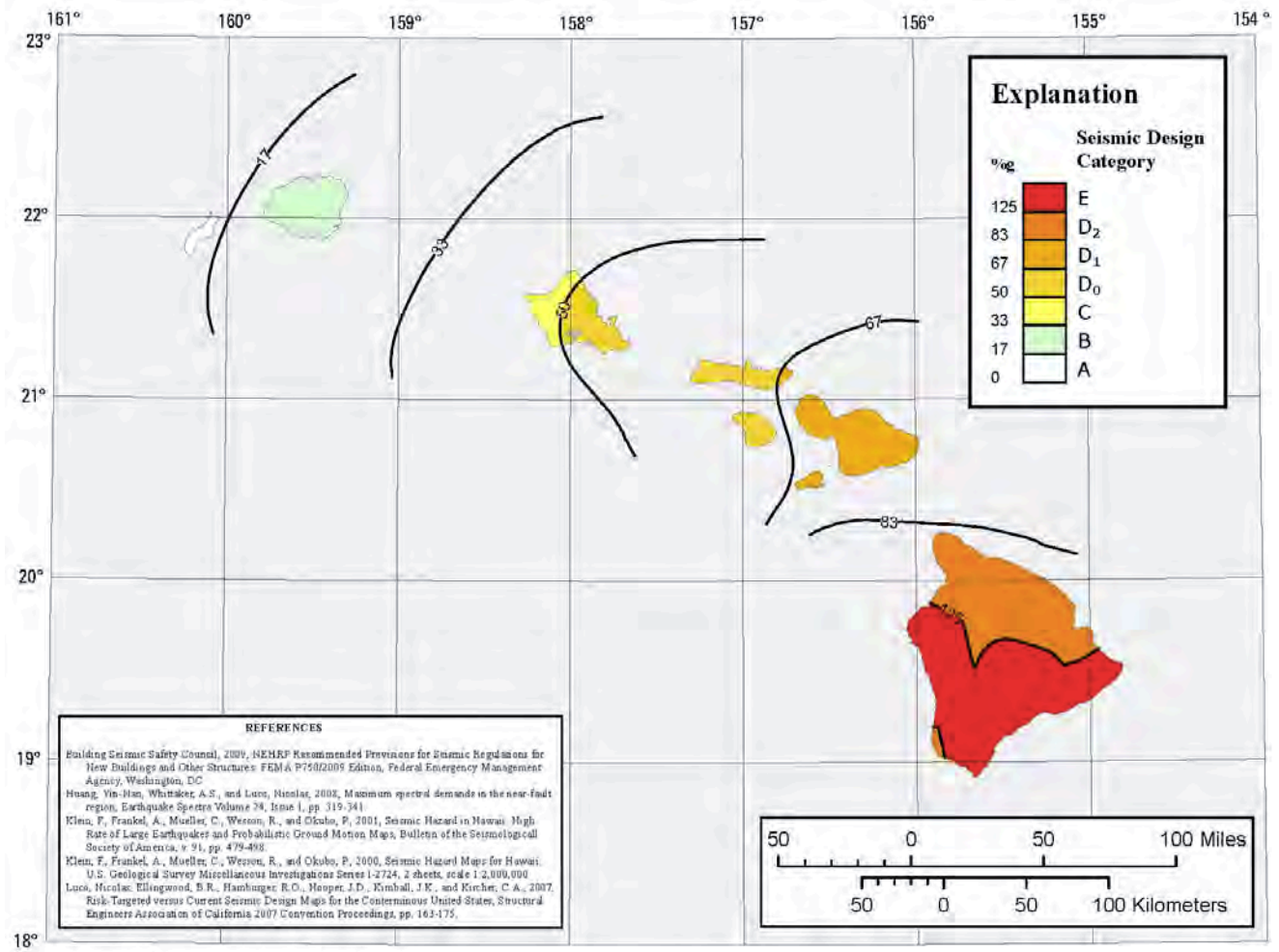
Building Seismic Safety Council, 2009, NEHRP Recommended Provisions for Seismic Regulations for New Buildings and Other Structures: FEMA P750/2009 Edition, Federal Emergency Management Agency, Washington, DC

Huang, Yin-Nan, Whittaker, A.S., and Luco, Nicolas, 2008, Maximum spectral demands in the near-fault region, Earthquake Spectra Volume 24, Issue 1, pp. 319-341.

Luco, Nicolas, Ellingwood, B.R., Hamburger, R.O., Hooper, J.D., Kimball, J.K., and Kircher, C.A., 2007, Risk-Targeted versus Current Seismic Design Maps for the Conterminous United States, Structural Engineers Association of California 2007 Convention Proceedings, pp. 143-175.

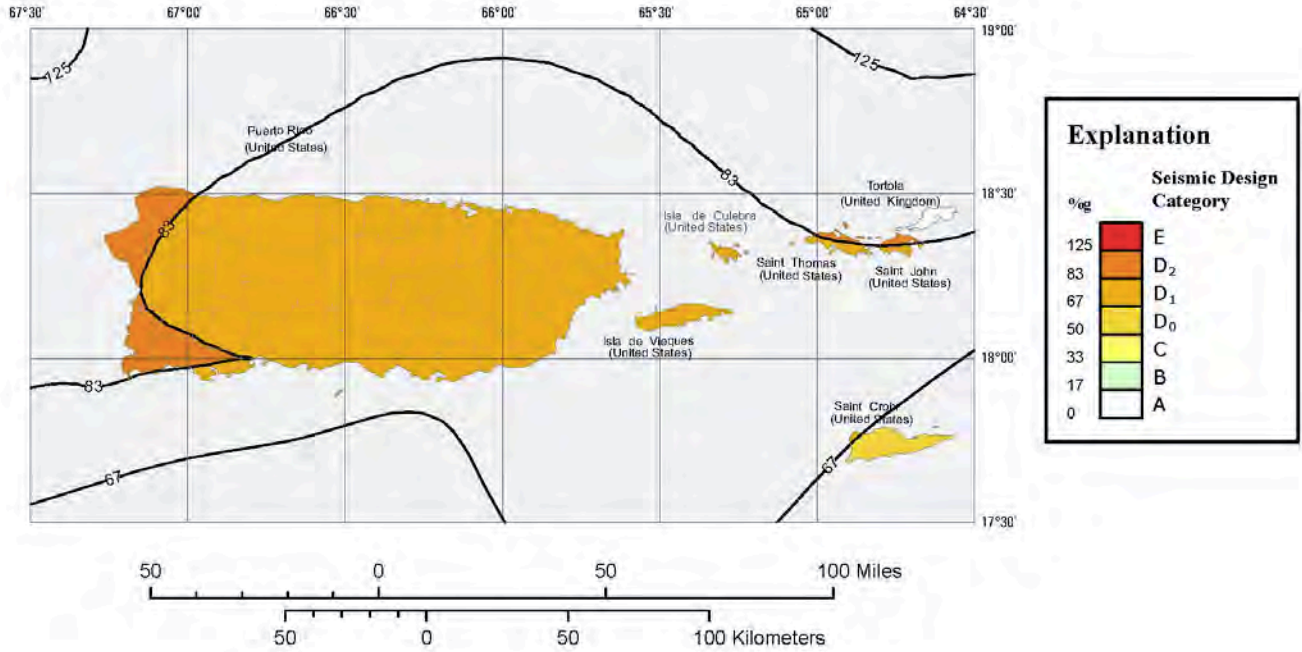
Wesson, Robert L., Boyd, Oliver S., Mueller, Charles S., Bufe, Charles G., Frankel, Arthur D., Peterson, Mark D., 2007, Revision of time-independent probabilistic seismic hazard maps for Alaska U.S. Geological Survey Open-File Report 2007-1043.

FIGURE R301.2(3)-continued
Alternate Seismic Design Categories



Map prepared by U.S. Geological Survey in collaboration with the Federal Emergency Management Agency (FEMA) Building Seismic Safety Council's (BSSC) Code Resource Support Committee (CRSC)

FIGURE R301.2(3)-continued
Alternate Seismic Design Categories



REFERENCES

Building Seismic Safety Council, 2009, NEHRP Recommended Provisions for Seismic Regulations for New Buildings and Other Structures, FEMA P750/2009 Edition, Federal Emergency Management Agency, Washington, DC
 Huang, Yin-Nan, Whitaker, A. S., and Lugo, Nicolas, 2005, Maximum spectral demands in the near fault region, Earthquake Spectra Volume 24, Issue 1, pp. 319-341.
 Lugo, Nicolas, Ellingwood, B. R., Hamburger, R. O., Hooper, J. D., Kimball, J. K., and Kircher, C. A., 2007, Risk Targeted versus Current Seismic Design Maps for the Conterminous United States, Structural Engineers Association of California 2007 Convention Proceedings, pp. 163-175.
 Mueller, C., Frankel, A., Peterien, M., and Leyendecker, E., 2003, Documentation for 2003 USGS Seismic Hazard Maps for Puerto Rico and the U.S. Virgin Islands, U.S. Geological Survey Open-File Report 03-375.

Map prepared by U.S. Geological Survey in collaboration with the Federal Emergency Management Agency (FEMA)-funded Building Seismic Safety Council's (BSSC) Code Research Support Committee (CRSC)

FIGURE R301.2(3)-continued
Alternate Seismic Design Categories

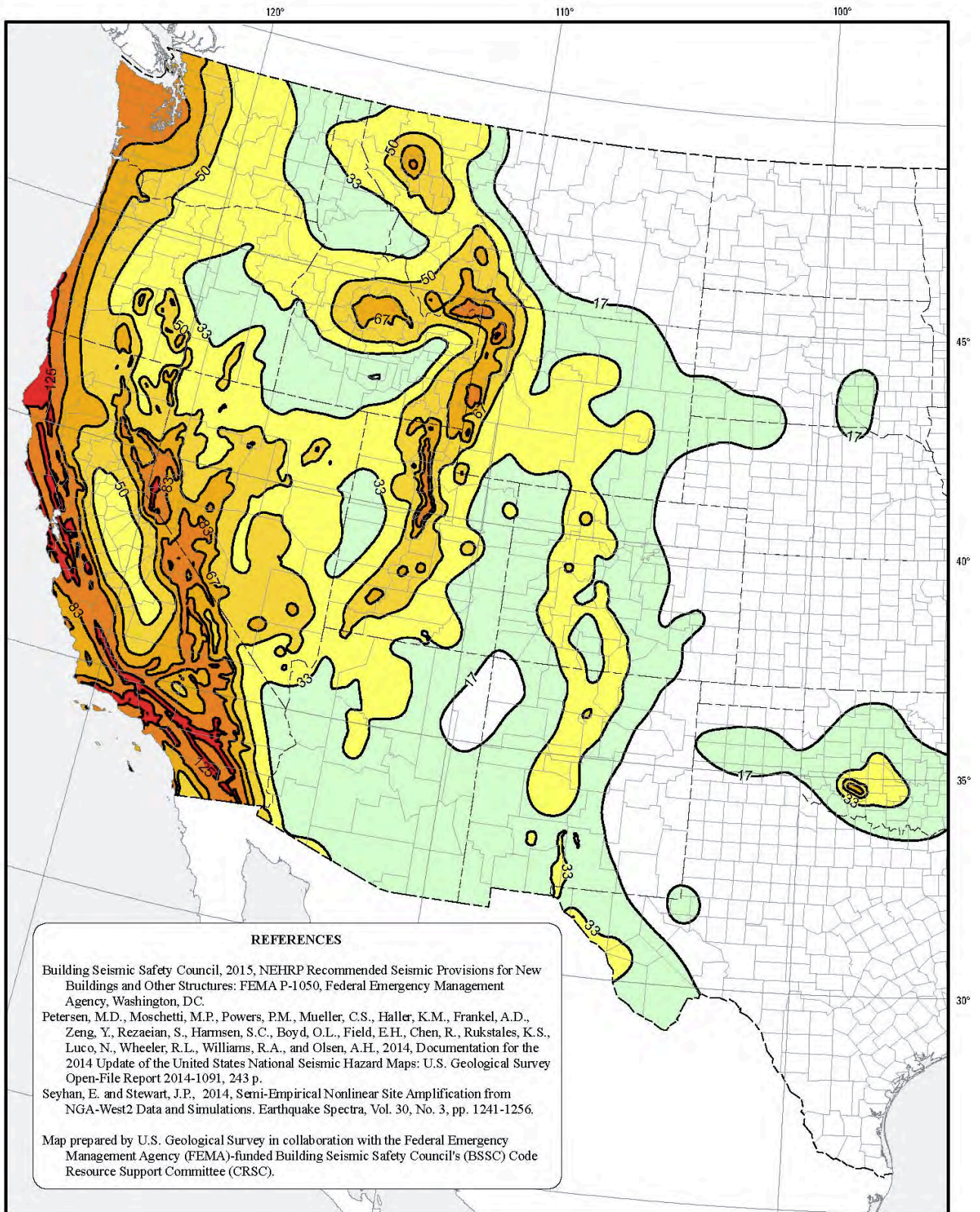
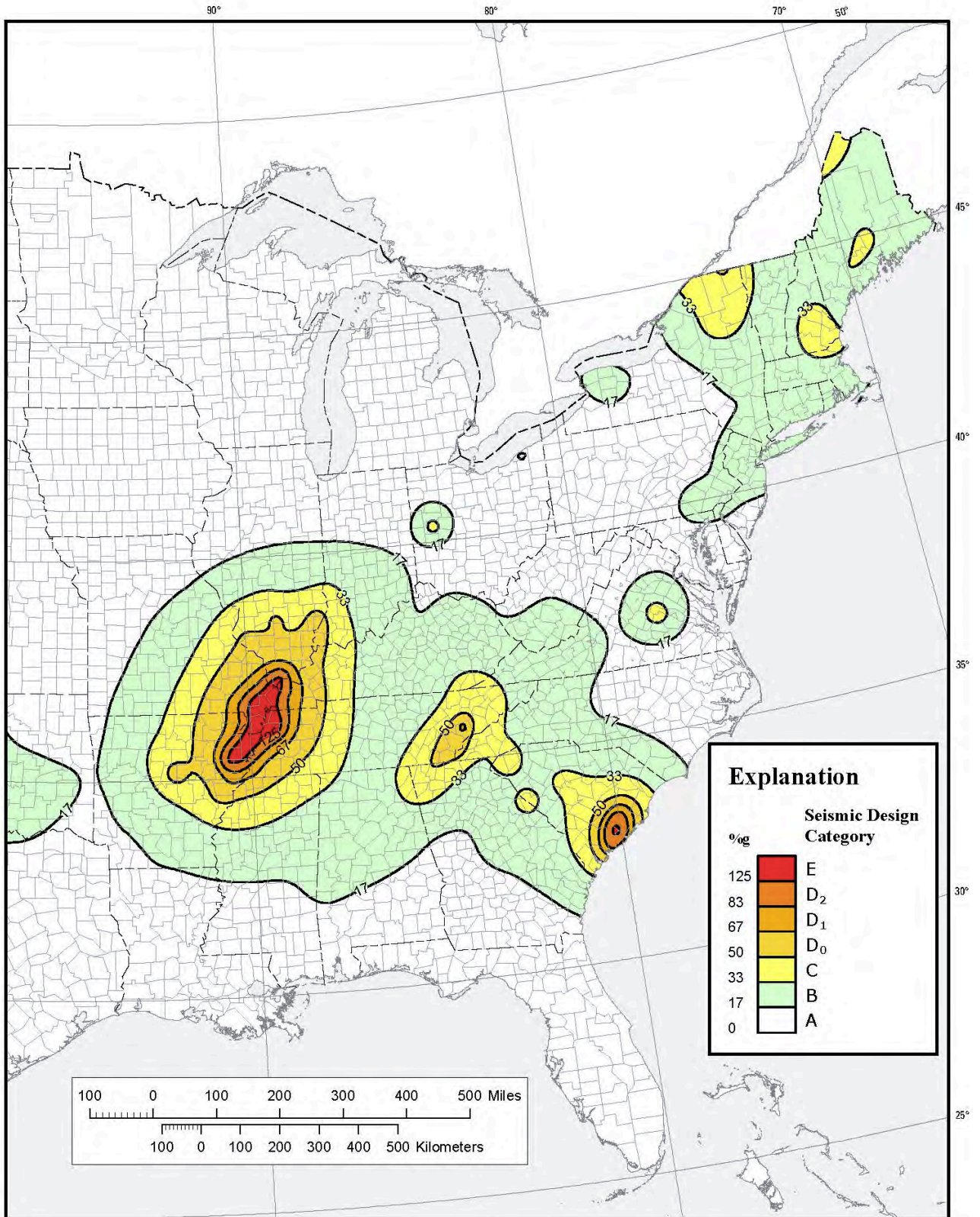


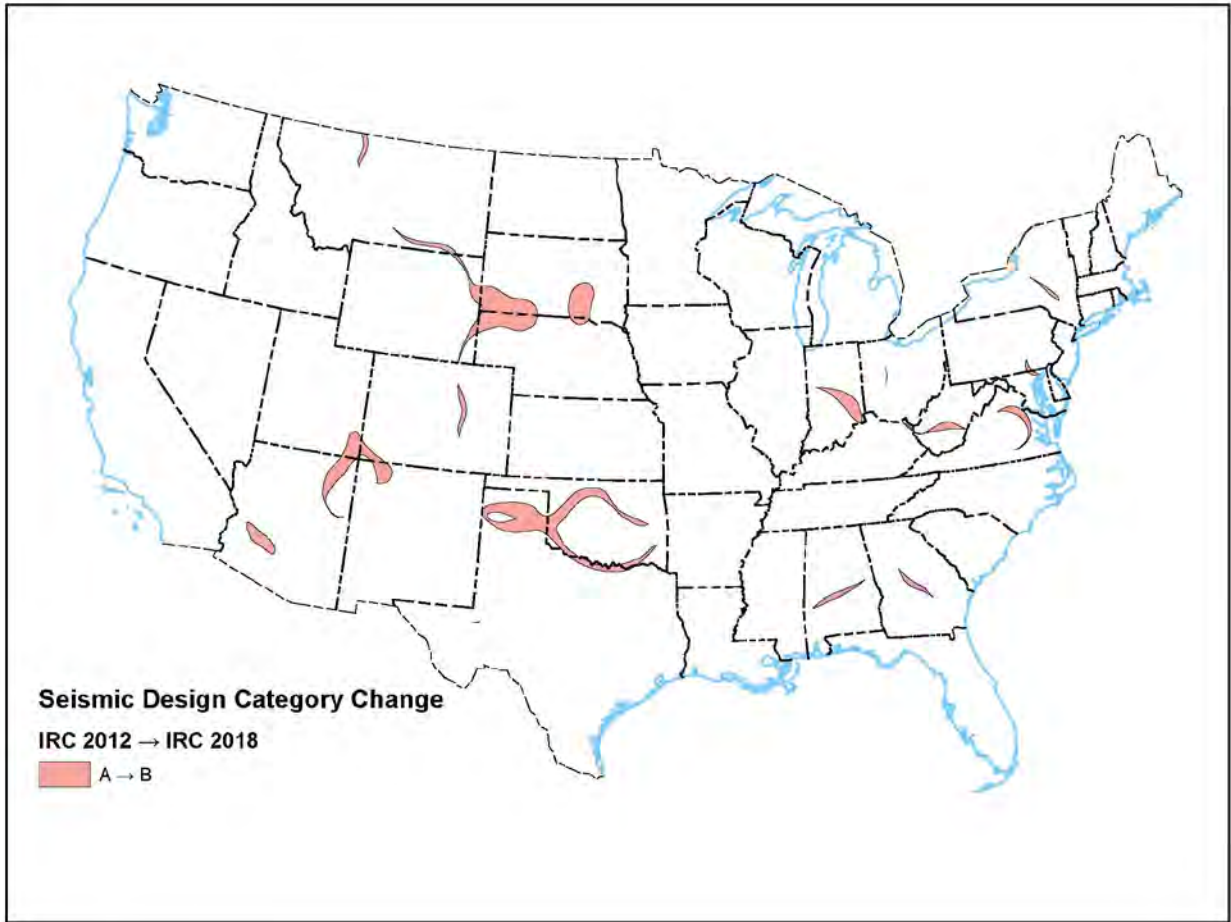
FIGURE R301.2(3)-continued
Alternate Seismic Design Categories

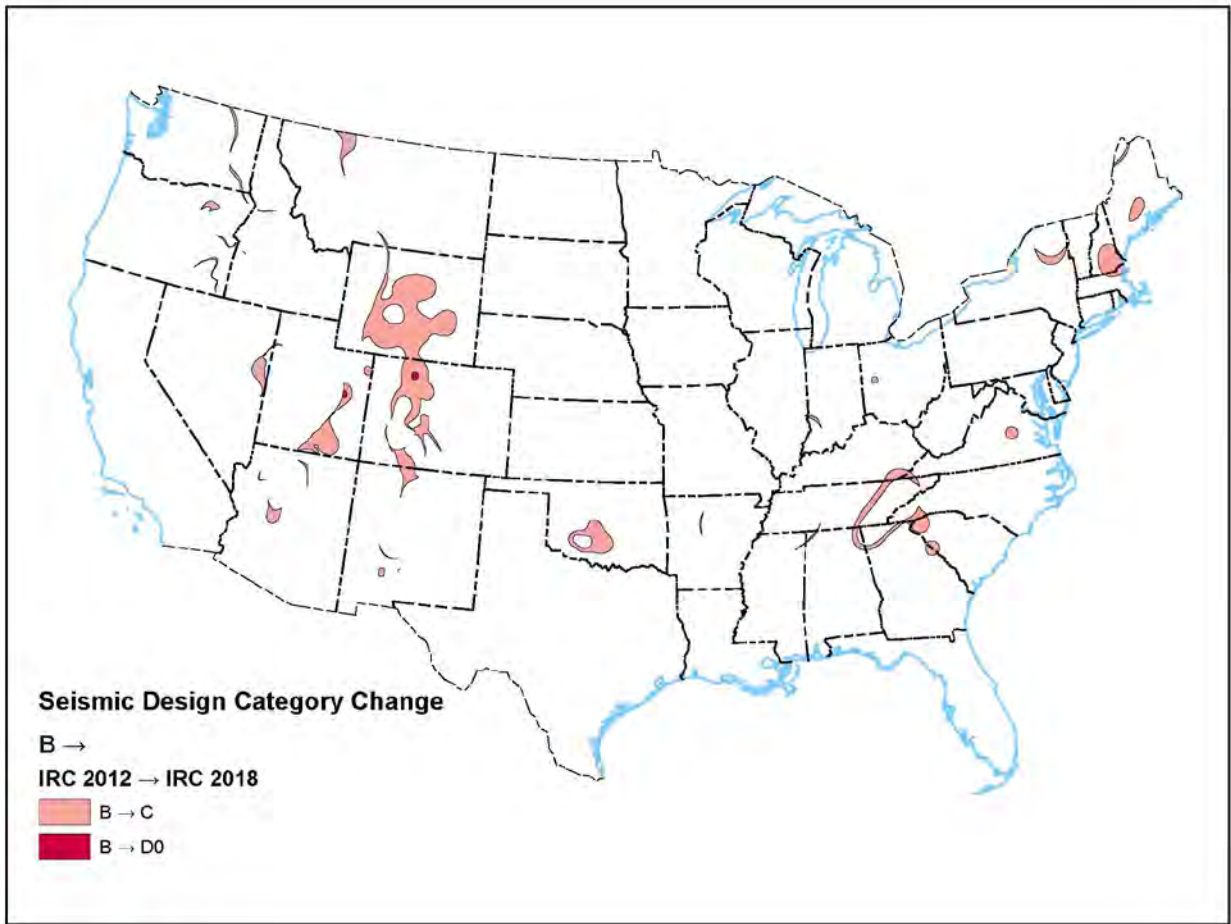


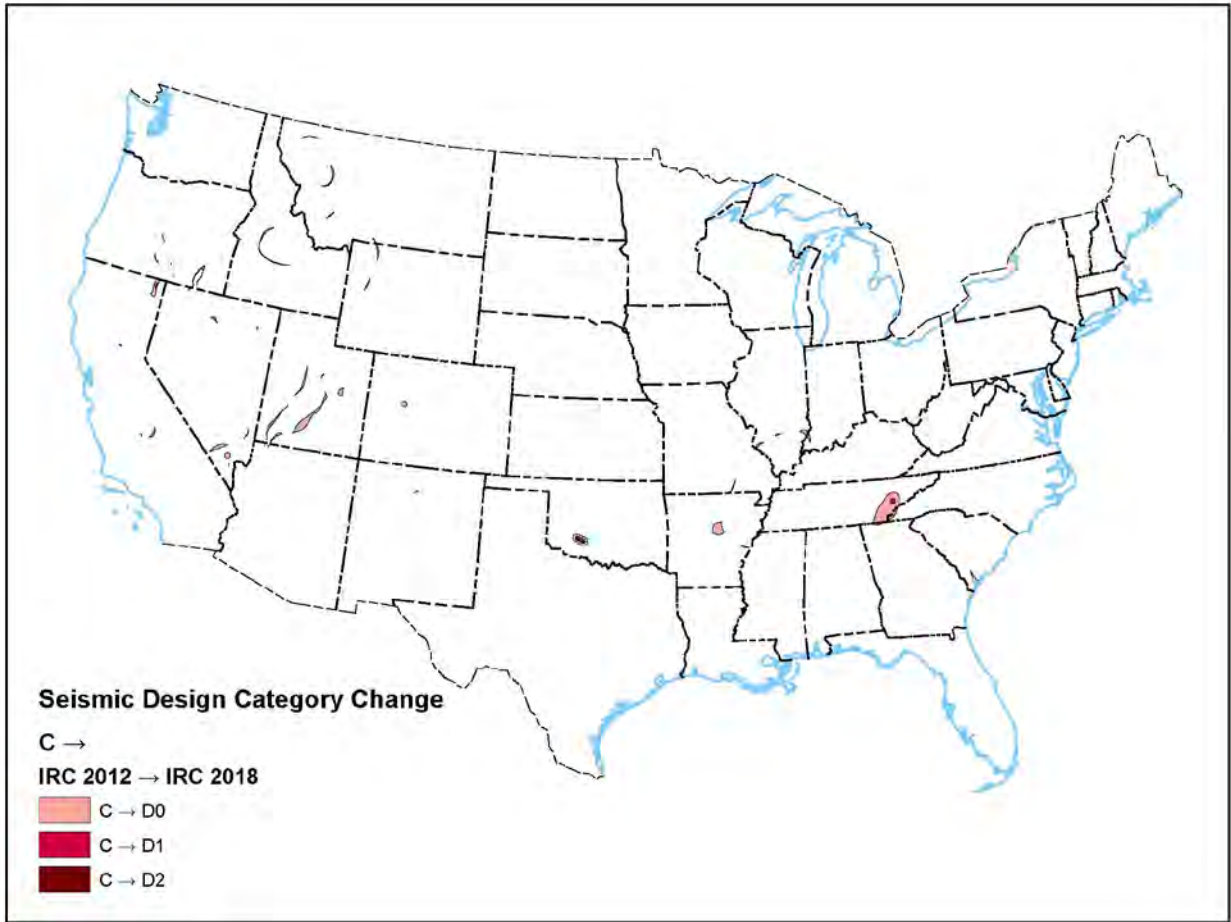
Reason: This proposal incorporates the most current seismic design maps prepared by the U.S. Geological Survey (USGS) in collaboration with the Federal Emergency Management Agency (FEMA) and the Building Seismic Safety Council (BSSC). A separate coordinated code change updates the seismic design maps in the IBC to be consistent with these IRC maps and the maps incorporated into ASCE 7-16. In addition to incorporating updated information on faults and ground motion attenuation, these maps incorporate revisions to site coefficients F_a and F_v . Technical reasons behind the revisions are documented in FEMA P-1050-1, 2015 Edition, Sections C11.4.2 (site classes), C11.4.3 (site coefficients), and C22 (seismic maps). Further documentation is provided in Seyhan and Stewart (2012, 2014) and Luco et al. (2015). As excerpted from FEMA P-1050-1, 2015 Edition, Section C11.4.3: "Motivation for the revisions to these site factors includes (Seyhan and Stewart, 2012): (1) updating the reference site condition used for the factors to match the condition on the national maps, which in $V_s=760$ m/s (2500 ft/s); (2) incorporating into the factors the substantial knowledge gains (stemming in large part from an enormous increase in available data) on site response over the past two decades."

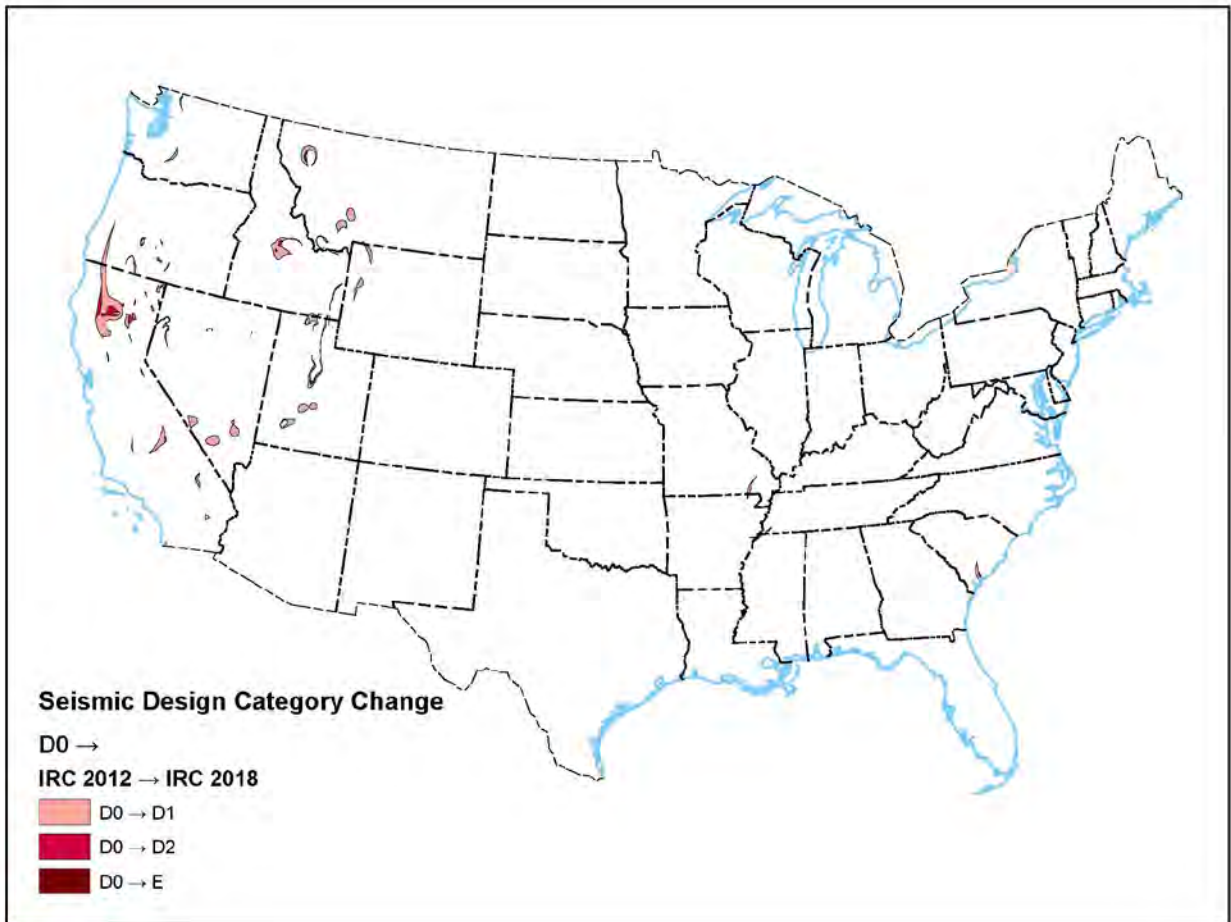
As in past versions, the IRC seismic design maps directly indicate Seismic Design Category for a given location. Development of the maps in the past incorporated a default assumption of a Site (soil) Class D, which provided the most conservative assignment of Seismic Design Category. For this update, (1) changes made to the site coefficients resulted in Site Class D no longer being the most critical site class at all spectral response acceleration levels, and (2) spectral response accelerations and resulting Seismic Design Categories increased at a number of locations when the most critical site coefficients were used. Because of these two effects, it is proposed that two sets of maps be adopted into the IRC. The updated R301.2(2) Seismic Design Category maps will provide the most conservative assignment of Seismic Design Category and can be used with any site/soil type within the limits of current IRC provisions. The new R301.2(3) Alternate Seismic Design Category maps will provide less conservative assignments of Seismic Design Category, permitted to be used when it can be determined that Site Class A, B or D is applicable. The building official may make a determination that use of the alternate maps is permitted, provided adequate information is available to determine site class, either on a community-wide basis or site-by-site basis. As in the past, alternate determination in accordance with the IBC is still permitted.

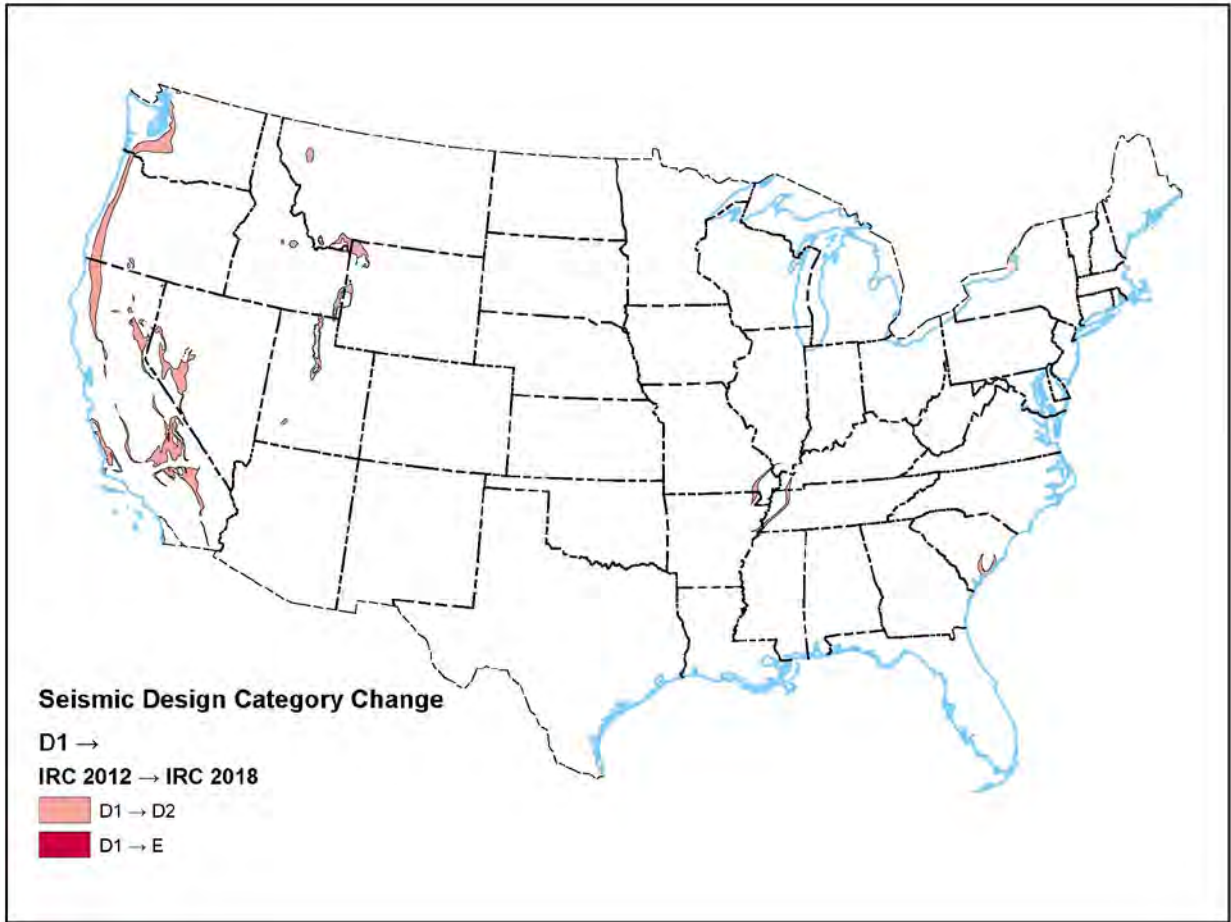
Maps have been developed by USGS to illustrate locations where Seismic Design Categories increase and decrease when comparing the 2015 IRC maps to the R301.2(2) default maps. These are included as an attachment to this code change proposal. Seyhan and Stewart (2014) and Luco et al. (2015) provide discussion of maps changes at some specific locations, including a region near Charleston, South Carolina where Seismic Design Category increased from D_2 to E. This increase is due to changes in both site coefficients and mapped ground motions, the latter due to an improved earthquake source model for the Central and Eastern United States developed through a three and one-half year collaboration of approximately 35 experts (<http://www.ceus-ssc.com>).



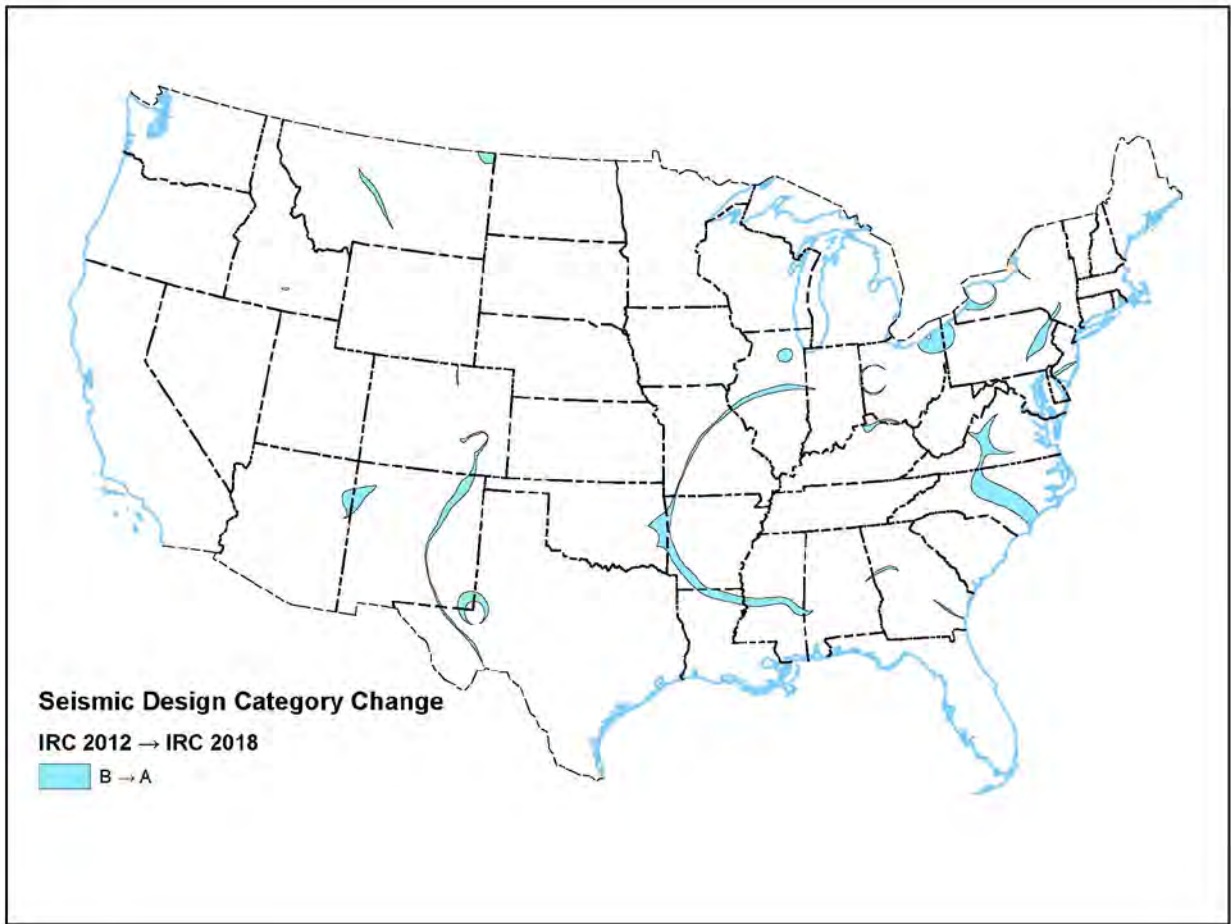


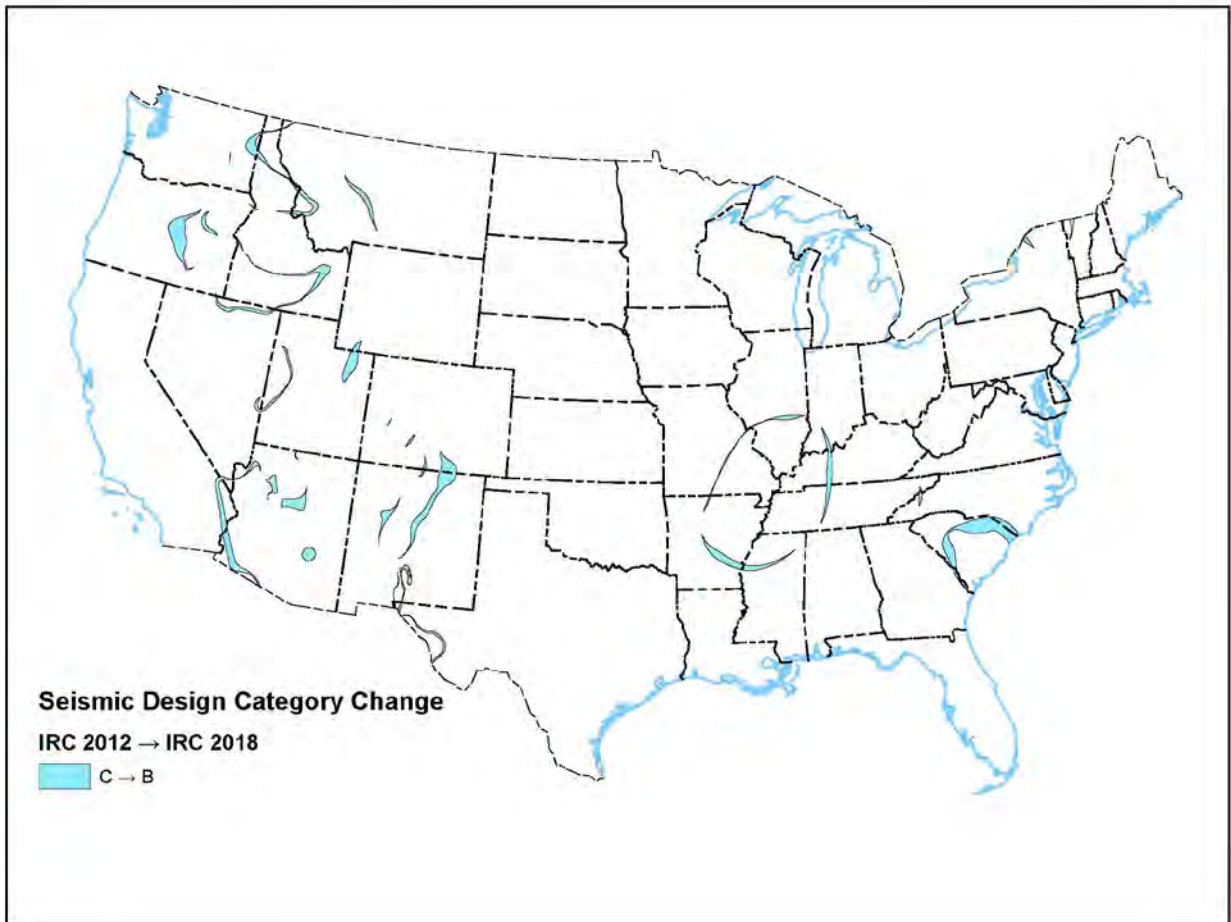


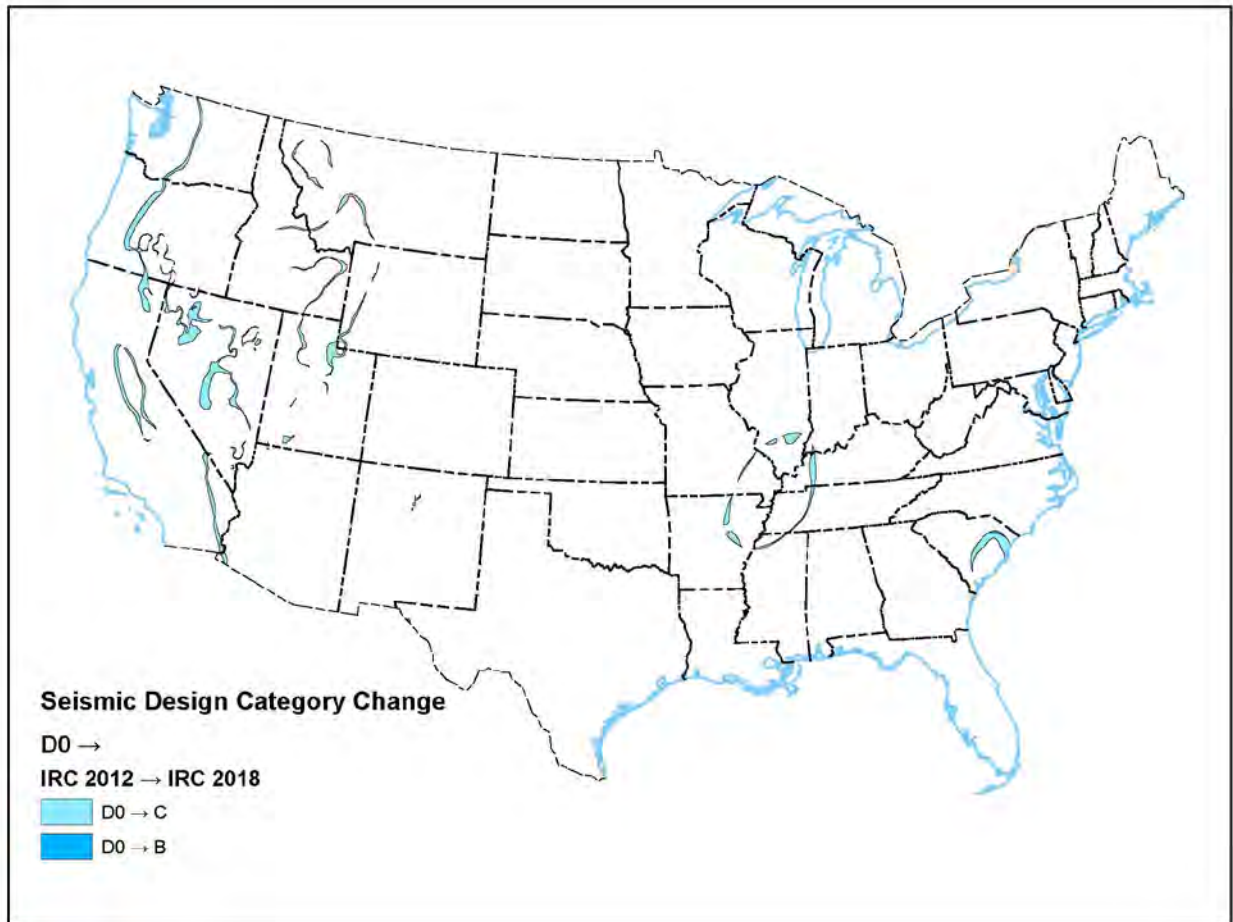


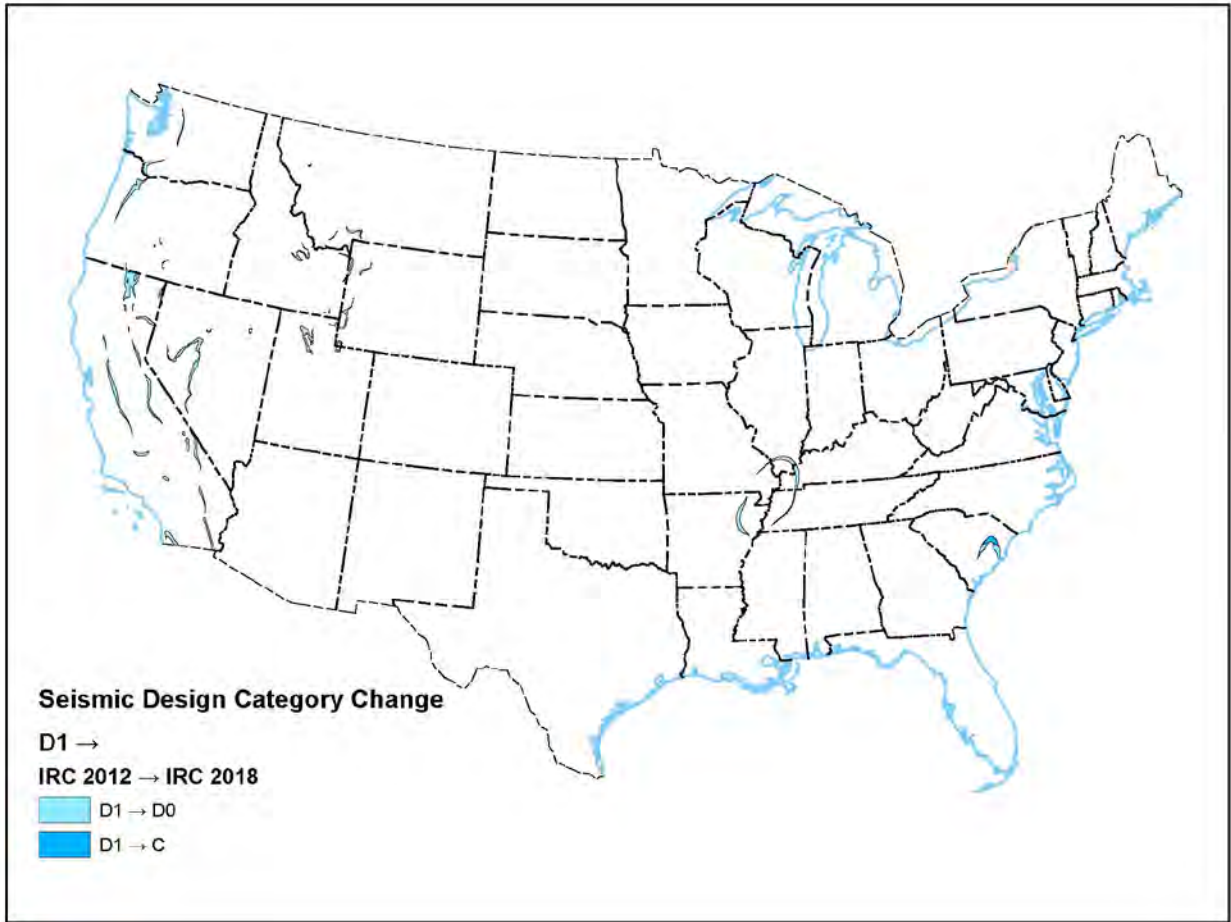


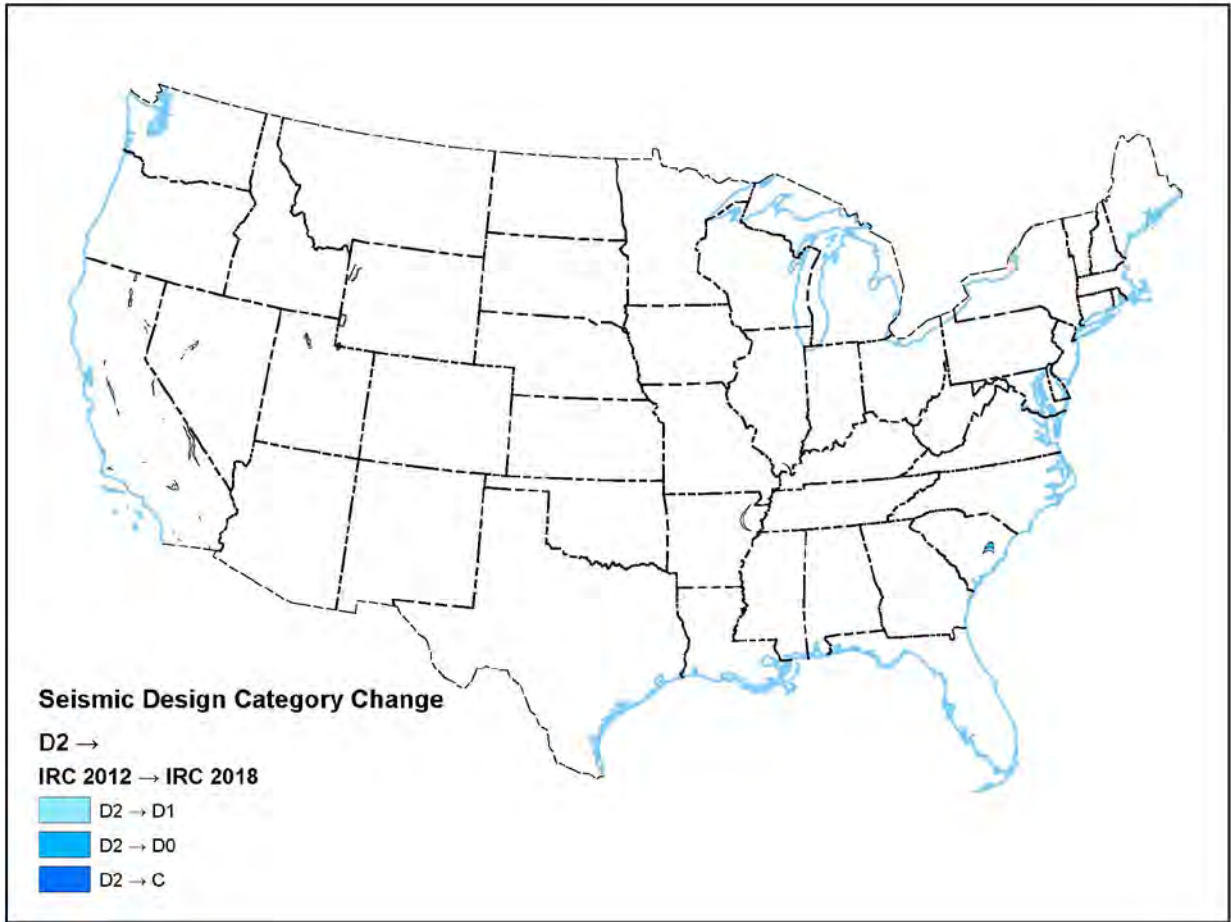


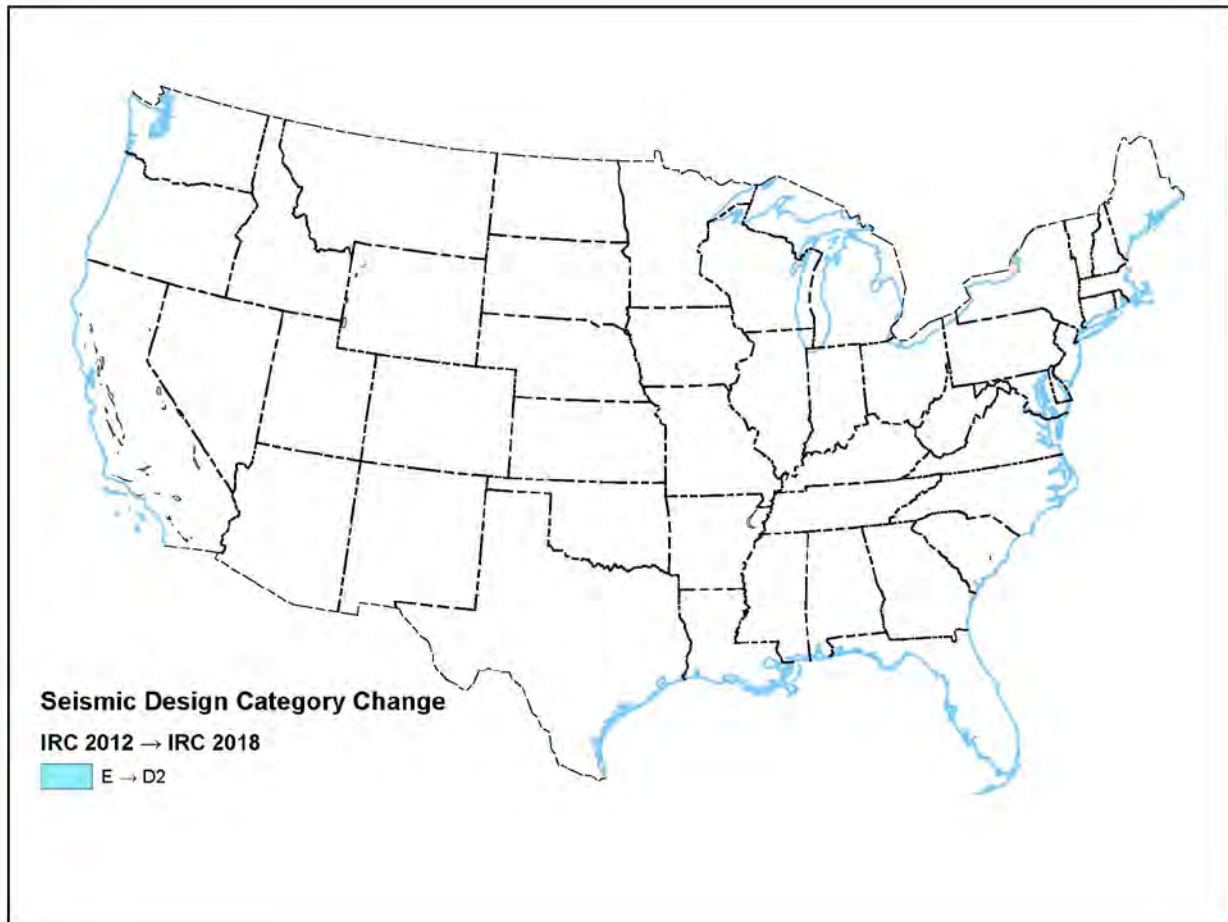












Bibliography: [NEHRP Recommended Seismic Provisions for New Buildings and Other Structures] [FEMA P-1050-1] [Building Seismic Safety Council] [2015] [Pages 189-194] [<https://www.fema.gov/media-library/assets/documents/107646>] [Geotechnical Engineering State of the Art and Practice, Keynote Lectures from GeoCongress 2012] [Site Response in NEHRP Provisions and NGA Models] [Seyahn, E. and Stewart, J.P.] [2012] [Pages 359-379] [Earthquake Spectra] [Semi-empirical Nonlinear Site Amplification from NGA West2 Data and Simulations] [Seyhan, E. and Stewart, J.] [2014] [Volume 30, pages 1241-1256] [Earthquake Spectra] [Updates to Building-Code Maps for the 2015 NEHRP Recommended Seismic Provisions] [Luco, N., Bachman, R.E., Crouse, C.B., Harris, J.R., Hooper, J.D., Kircher, C.A., Caldwell, P.J., and Rukstales, K.S.] [2015] [Volume 31, pages S245-S271]

Cost Impact: Will increase the cost of construction

This code change can result in modest increases OR decreases in construction cost depending on geographic region. Where the R301.2(2) Seismic Design Category maps are used, limited locations as illustrated by the attached USGS maps, will increase or decrease in Seismic Design Category, increasing or decreasing seismic bracing requirements and cost a modest amount. The amount of increase will vary depending on the specific change in Seismic Design Category, the wind bracing requirements, and the particulars of the dwelling and its construction. In some cases increases in Seismic Design Category and resulting cost can be reduced if not eliminated where the site soils allow the use of the Alternate Seismic Design Category maps. NIST GCR 14-917-26, *Cost Analyses and Benefits for Earthquake-Resistant Construction in Memphis, Tennessee*, provides one example of the magnitude of seismic design cost impact; the increment in cost for apartment building construction between design for code-required wind loads and national seismic design provisions is on the order of one percent of construction cost.

Analysis: Colored images will be converted to gray scale for printed codes.
 Coordinated code change proposal for the IBC is S119-16.

**Report of Committee Action
Hearings**

Committee Action:

Approved as Submitted

Committee Reason: The updated maps in this proposal are based on more current information and they provide a measure of flexibility that has not been included in the code in the past.

Assembly Motion:

Disapprove

Online Vote Results:

Failed

Support: 34.18% (94) Oppose: 65.82% (181)

Assembly Action:

None

Final Action Results

RB17-16

AS

[←BACK](#)

Code Change No: **RB23-16**

Original Proposal

Section: R301.2.2, R301.2.2.4

Proponent: Edward Kulik, representing Building Code Action Committee (bcac@iccsafe.org)

Revise as follows:

R301.2.2 Seismic provisions. Buildings in Seismic Design Categories C, D₀, D₁, D₂ and E shall be constructed in accordance with the requirements of this section and other seismic requirements of this code. The seismic provisions of this code shall apply as follows:

1. *Townhouses* in Seismic Design Categories C, D₀, D₁ and D₂.
2. Detached one- and two-family *dwellings* in Seismic Design Categories, D₀, D₁ and D₂.

~~R301.2.2.4 Seismic Design Category E.~~ Buildings in Seismic Design Category E shall be designed to resist seismic loads in accordance with the *International Building Code*, except where the seismic design category is reclassified to a lower seismic design category in accordance with Section R301.2.2.1. Components of buildings not required to be designed to resist seismic loads shall be constructed in accordance with the provisions of this code.

Reason: The purpose of this code change is to clarify the application of the IRC for seismic design. In reviewing the organization of Section R301.2.2, it was noted that the opening paragraph of R301.2.2 tells you how the seismic provisions of the IRC apply to detached dwellings and townhouses in SDC C, D₀, D₁ and D₂, but say nothing about SDC E. It is not until you get to R301.2.2.4 at the end of the section that you are told to go to the IBC for dwellings in SDC E, unless the alternative SDC determinations apply. This change proposes to relocate Section R301.2.2.4 to the front of Section R301.2.2 so all of the SDC's of interest are addressed in one place.

This proposal is submitted by the ICC Building Code Action Committee (BCAC). BCAC was established by the ICC Board of Directors to pursue opportunities to improve and enhance assigned International Codes or portions thereof. In 2014 and 2015 the BCAC has held 5 open meetings. In addition, there were numerous Working Group meetings and conference calls for the current code development cycle, which included members of the committee as well as any interested party to discuss and debate the proposed changes. Related documentation and reports are posted on the BCAC website at: [BCAC](#)

Cost Impact: Will not increase the cost of construction

The code change provides editorial clarifications to the application of the code in high-seismic areas. No seismic requirements are added or removed with this change, thus there should be no impact on cost.

Report of Committee Action Hearings

Committee Action:

Approved as Modified

Modify as follows:

R301.2.2 Seismic provisions. Buildings in Seismic Design Categories C, D₀, D₁, D₂ and ~~E-D₂~~ shall be constructed in accordance with the requirements of this section and other seismic requirements of this code. The seismic provisions of this code shall apply as follows:

1. *Townhouses* in Seismic Design Categories C, D₀, D₁ and D₂.
2. Detached on- and two-family dwellings in Seismic Design Categories D₀, D₁ and D₂.

(Portions of proposal not shown to remain unchanged)

Committee Reason: The modification is necessary to correct the Seismic Zone references. The proposal is a good change that clarifies the seismic requirements of the International Residential Code.

Assembly Action

None

Final Action Results

RB23-16

AM

Code Change No: **RB24-16**

Original Proposal

Section: R301.2.2, R301.2.2.2, R301.2.2.2.1, R301.2.2.2.2, R301.2.2.2.3, R301.2.2.2.4, R301.2.2.2.5, R301.2.2.3, R301.2.2.3.1, R301.2.2.3.2, R301.2.2.3.3, R301.2.2.3.4, R301.2.2.3.5, R301.2.2.3.6, R301.2.2.3.7, R301.2.2.4, R301.2.2.6.1 (New), R301.2.2.6.2 (New), R301.2.2.6.3 (New), R301.2.2.6.4 (New), R301.2.2.6.5 (New), R301.2.2.6.6 (New), R301.2.2.6.7 (New)

Proponent: Edward Kulik, representing Building Code Action Committee (bcac@iccsafe.org)

Revise as follows:

R301.2.2 Seismic provisions. The Buildings in Seismic Design Categories C, D₀, D₁, D₂ and E shall be constructed in accordance with the requirements of this section and other seismic requirements of this code. The seismic provisions of this code shall apply as follows:

1. Townhouses in Seismic Design Categories C, D₀, D₁ and D₂.
2. Detached one- and two-family *dwelling*s in Seismic Design Categories, D₀, D₁ and D₂.

~~R301.2.2.2.1~~ R301.2.2.2 **Weights of materials.** Average dead loads shall not exceed 15 pounds per square foot (720 Pa) for the combined roof and ceiling assemblies (on a horizontal projection) or 10 pounds per square foot (480 Pa) for floor assemblies, except as further limited by Section R301.2.2. Dead loads for walls above *grade* shall not exceed:

1. Fifteen pounds per square foot (720 Pa) for exterior light-frame wood walls.
2. Fourteen pounds per square foot (670 Pa) for exterior light-frame cold-formed steel walls.
3. Ten pounds per square foot (480 Pa) for interior light-frame wood walls.
4. Five pounds per square foot (240 Pa) for interior light-frame cold-formed steel walls.
5. Eighty pounds per square foot (3830 Pa) for 8-inch-thick (203 mm) masonry walls.
6. Eighty-five pounds per square foot (4070 Pa) for 6-inch-thick (152 mm) concrete walls.
7. Ten pounds per square foot (480 Pa) for SIP walls.

Exceptions:

1. Roof and ceiling dead loads not exceeding 25 pounds per square foot (1190 Pa) shall be permitted provided that the wall bracing amounts in Section R602.10.3 are increased in accordance with Table R602.10.3(4).
2. Light-frame walls with stone or masonry veneer shall be permitted in accordance with the provisions of Sections R702.1 and R703.
3. Fireplaces and chimneys shall be permitted in accordance with Chapter 10.

~~R301.2.2.2.2~~ R301.2.2.3 **Stone and masonry veneer.** *No change to text.*

~~R301.2.2.2.3~~ R301.2.2.4 **Masonry construction.** Masonry construction shall comply with the requirements of Section R606.12. Masonry construction in Seismic Design Categories D₀ and D₁ shall comply with the requirements of Section R606.12.1. Masonry construction in Seismic Design Category D₂ shall comply with the requirements of Section R606.12.4.

~~R301.2.2.3.4~~ 301.2.2.5 **Concrete construction.** Buildings with exterior above-*grade* concrete walls shall comply with PCA 100 or shall be designed in accordance with ACI 318.

Exception: Detached one- and two-family dwellings in Seismic Design Category C with exterior above grade concrete walls are allowed to comply with the requirements of Section R608.

R301.2.2.2.5 R301.2.2.6 Irregular buildings. The seismic provisions of this code shall not be used for irregular structures, or portions thereof, located in Seismic Design Categories C, D₀, D₁ and D₂ and considered to be irregular in accordance with this section. A building or portion of a building shall be considered to be irregular where one or more of the conditions defined in Sections R301.2.2.6.1 through R301.2.2.6.7 occur. Irregular structures, or irregular portions of structures, shall be designed in accordance with accepted engineering practice to the extent the irregular features affect the performance of the remaining structural system. Where the forces associated with the irregularity are resisted by a structural system designed in accordance with accepted engineering practice, design of the remainder of the building shall be permitted to be designed using the provisions of this code. A building or portion of a building shall be considered to be irregular where one or more of the following conditions occur:

1. Where exterior shear wall lines or braced wall panels are not in one plane vertically from the foundation to the uppermost story in which they are required.

Exception: For wood light frame construction, floors with cantilevers or setbacks not exceeding four times the nominal depth of the wood floor joists are permitted to support braced wall panels that are out of plane with braced wall panels below provided that:

1. Floor joists are nominal 2 inches by 10 inches (51 mm by 254 mm) or larger and spaced not more than 16 inches (406 mm) on center.
2. The ratio of the back span to the cantilever is not less than 2 to 1.
3. Floor joists at ends of braced wall panels are doubled.
4. For wood frame construction, a continuous rim joist is connected to ends of cantilever joists. When spliced, the rim joists shall be spliced using a galvanized metal tie not less than 0.058 inch (1.5 mm) (16 gage) and 1 1/2 inches (38 mm) wide fastened with six 16d nails on each side of the splice or a block of the same size as the rim joist of sufficient length to fit securely between the joist space at which the splice occurs fastened with eight 16d nails on each side of the splice; and
5. Gravity loads carried at the end of cantilevered joists are limited to uniform wall and roof loads and the reactions from headers having a span of 8 feet (2438 mm) or less.

2. Where a section of floor or roof is not laterally supported by shear walls or braced wall lines on all edges.

Exception: Portions of floors that do not support shear walls or braced wall panels above, or roofs, shall be permitted to extend not more than 6 feet (1829 mm) beyond a shear wall or braced wall line.

3. Where the end of a braced wall panel occurs over an opening in the wall below and ends at a horizontal distance greater than 1 foot (305 mm) from the edge of the opening. This provision is applicable to shear walls and braced wall panels offset in plane and to braced wall panels offset out of plane as permitted by the exception to Item 1.

Exception: For wood light frame wall construction, one end of a braced wall panel shall be permitted to extend more than 1 foot (305 mm) over an opening not more than 8 feet (2438 mm) in width in the wall below provided that the opening includes a header in accordance with the following:

1. The building width, loading condition and framing member species limitations of Table R602.7(1) shall apply; and
2. Not less than one 2 x 12 or two 2 x 10 for an opening not more than 4 feet (1219 mm) wide; or

- ~~3. Not less than two 2 x 12 or three 2 x 10 for an opening not more than 6 feet (1829 mm) in width; or~~
- ~~4. Not less than three 2 x 12 or four 2 x 10 for an opening not more than 8 feet (2438 mm) in width; and~~
- ~~5. The entire length of the braced wall panel does not occur over an opening in the wall below.~~
- ~~4. Where an opening in a floor or roof exceeds the lesser of 12 feet (3658 mm) or 50 percent of the least floor or roof dimension.~~
- ~~5. Where portions of a floor level are vertically offset.~~

Exceptions:

- ~~1. Framing supported directly by continuous foundations at the perimeter of the building.~~
- ~~2. For wood light frame construction, floors shall be permitted to be vertically offset when the floor framing is lapped or tied together as required by Section R502.6.1.~~
- ~~6. Where shear walls and braced wall lines do not occur in two perpendicular directions.~~
- ~~7. Where stories above gradeplane partially or completely braced by wood wall framing in accordance with Section R602 or cold-formed steel wall framing in accordance with Section R603 include masonry or concrete construction. Where this irregularity applies, the entire story shall be designed in accordance with accepted engineering practice.~~

Exception: Fireplaces, chimneys and masonry veneer as permitted by this code.

R301.2.2.6.1 Shear wall or braced wall offsets out of plane. Where exterior shear wall lines or braced wall panels are not in one plane vertically from the foundation to the uppermost story in which they are required.

Exception: For wood light-frame construction, floors with cantilevers or setbacks not exceeding four times the nominal depth of the wood floor joists are permitted to support braced wall panels that are out of plane with braced wall panels below provided that:

1. Floor joists are nominal 2 inches by 10 inches (51 mm by 254 mm) or larger and spaced not more than 16 inches (406 mm) on center.
2. The ratio of the back span to the cantilever is not less than 2 to 1.
3. Floor joists at ends of braced wall panels are doubled.
4. For wood-frame construction, a continuous rim joist is connected to ends of cantilever joists. When spliced, the rim joists shall be spliced using a galvanized metal tie not less than 0.058 inch (1.5 mm) (16 gage) and 1 1/2 inches (38 mm) wide fastened with six 16d nails on each side of the splice or a block of the same size as the rim joist of sufficient length to fit securely between the joist space at which the splice occurs fastened with eight 16d nails on each side of the splice; and
5. Gravity loads carried at the end of cantilevered joists are limited to uniform wall and roof loads and the reactions from headers having a span of 8 feet (2438 mm) or less.

R301.2.2.6.2 Lateral support of roofs and floors. Where a section of floor or roof is not laterally supported by shear walls or braced wall lines on all edges.

Exception: Portions of floors that do not support shear walls or braced wall panels above, or roofs, shall be permitted to extend not more than 6 feet (1829 mm) beyond a shear wall or braced wall line.

R301.2.2.6.3 Shear wall or braced wall offsets in plane. Where the end of a braced wall panel occurs over an opening in the wall below and extends more than 1 foot (305 mm) horizontally past the edge of the opening. This provision is applicable to shear walls and braced wall panels offset in plane and to

braced wall panels offset out of plane as permitted by the exception to Section R301.2.2.6.1.

Exception: For wood light-frame wall construction, one end of a braced wall panel shall be permitted to extend more than 1 foot (305 mm) over an opening not more than 8 feet (2438 mm) in width in the wall below provided that the opening includes a header in accordance with the following:

1. The building width, loading condition and framing member species limitations of Table R602.7(1) shall apply; and
2. Not less than one 2 x 12 or two 2 x 10 for an opening not more than 4 feet (1219 mm) wide;
or
3. Not less than two 2 x 12 or three 2 x 10 for an opening not more than 6 feet (1829 mm) in width; or
4. Not less than three 2 x 12 or four 2 x 10 for an opening not more than 8 feet (2438 mm) in width; and
5. The entire length of the braced wall panel does not occur over an opening in the wall below.

R301.2.2.6.4 Floor and roof openings. Where an opening in a floor or roof exceeds the lesser of 12 feet (3658 mm) or 50 percent of the least floor or roof dimension.

R301.2.2.6.5 Floor level offsets. Where portions of a floor level are vertically offset.

Exceptions:

1. Framing supported directly by continuous foundations at the perimeter of the building.
2. For wood light-frame construction, floors shall be permitted to be vertically offset when the floor framing is lapped or tied together as required by Section R502.6.1.

R301.2.2.6.6 Perpendicular shear walls and wall bracing. Where shear walls and braced wall lines do not occur in two perpendicular directions.

R301.2.2.6.7 Wall bracing in stories containing masonry or concrete construction. Where stories above grade plane partially or completely braced by wood wall framing in accordance with Section R602 or cold-formed steel wall framing in accordance with Section R603 include masonry or concrete construction. Where this irregularity applies, the entire story shall be designed in accordance with accepted engineering practice.

Exception: Fireplaces, chimneys and masonry veneer as permitted by this code.

~~**R301.2.2.3.1 R301.2.2.7 Height limitations.** Wood-framed buildings shall be limited to three stories above gradeplane or the limits given in Table R602.10.3(3). Cold-formed, steel-framed buildings shall be limited to less than or equal to three stories above gradeplane in accordance with AISI S230. Mezzanines as defined in Section R202 that comply with Section R325 shall not be considered as stories. Structural insulated panel buildings shall be limited to two stories above *gradeplane*.~~

~~**R301.2.2.3.5 R301.2.2.8 Cold-formed steel framing in Seismic Design Categories D₀, D₁ and D₂.** No change to text.~~

Delete without substitution:

~~**R301.2.2.3.3 Masonry construction.** Masonry construction in Seismic Design Categories D₀ and D₁ shall comply with the requirements of Section R606.12.1. Masonry construction in Seismic Design Category D₂ shall comply with the requirements of Section R606.12.4.~~

Revise as follows:

~~**R301.2.2.3.6 R301.2.2.9 Masonry chimneys.** Masonry~~

In Seismic Design Categories D0, D1 and D2, masonry chimneys shall be reinforced and anchored to the building in accordance with Sections R1003.3 and R1003.4.

~~**R301.2.2.3.7 R301.2.2.10 Anchorage of water heaters.** Water~~ In Seismic Design Categories D0, D1 and D2, water heaters shall be anchored against movement and overturning in accordance with Section M1307.2.

~~**R301.2.2.4 R301.2.2.11 Seismic Design Category E.** No change to text.~~

Delete without substitution:

~~**R301.2.2.2 Seismic Design Category C.** Structures assigned to Seismic Design Category C shall conform to the requirements of this section.~~

~~**R301.2.2.2.4 Concrete construction.** Detached one- and two-family dwellings with exterior above-grade concrete walls shall comply with the requirements of Section R608, PCA 100 or shall be designed in accordance with ACI 318. Townhouses with above-grade exterior concrete walls shall comply with the requirements of PCA 100 or shall be designed in accordance with ACI 318.~~

~~**R301.2.2.3 Seismic Design Categories D0, D1 and D2.** Structures assigned to Seismic Design Categories D0, D1 and D2 shall conform to the requirements for Seismic Design Category C and the additional requirements of this section.~~

~~**R301.2.2.3.2 Stone and masonry veneer.** Anchored stone and masonry veneer shall comply with the requirements of Sections R702.1 and R703.~~

Reason: The purpose of this code change is to reorganize the seismic provisions of Chapter 3. Builders in regions of the country where seismic design is required have expressed confusion regarding the requirements and limitations of Section R301.2.2. The key changes are as follows:

1. R301.2.2 is currently divided into requirements applicable to SDC C, then additional requirements applicable to SDC D0, D1 and D2, followed by the provision on SDC E. This change proposes to organize the provisions by type of construction or type of limitation instead of by SDC. By doing so, sections on stone and masonry veneer, masonry construction, and concrete construction that are somewhat or entirely duplicative can be combined. Also, this will promote the weight and irregularity limits up one level.
2. The irregular building provisions have been a source of confusion because they are currently provided as a number list of conditions that knock you out of the IRC, with exceptions that allow you to stay in the IRC but that themselves contain numbered lists! This code change creates new subsections for each irregularity, eliminating one set of numbered lists.
3. The height limitations are simplified. There is no need to restate for wood and cold-formed steel buildings the limit of 3 stories above grade plane, which simply reflects the IRC scope in Section R101.2. The mezzanine and SIP provisions are retained.

This proposal is submitted by the ICC Building Code Action Committee (BCAC). BCAC was established by the ICC Board of Directors to pursue opportunities to improve and enhance assigned International Codes or portions thereof. In 2014 and 2015 the BCAC has held 5 open meetings. In addition, there were numerous Working Group meetings and conference calls for the current code development cycle, which included members of the committee as well as any interested party to discuss and debate the proposed changes. Related documentation and reports are posted on the BCAC website at: [BCAC](#)

Cost Impact: Will not increase the cost of construction

The code change provides an editorial clarification and reorganization to the irregularity and material requirements and limitations in high-seismic areas. No seismic requirements are added or removed with this change, thus there should be no impact on cost.

Report of Committee Action Hearings
--

Committee Action:

Approved as Modified

Modify as follows:

R301.2.2 Seismic provisions. Buildings in Seismic Design Categories C, D₀, D₁, D₂ and E-D₂ shall be constructed in accordance with the requirements of this section and other seismic requirements of this code. The seismic provisions of this code shall apply as follows:

1. *Townhouses* in Seismic Design Categories C, D₀, D₁ and D₂.
2. Detached on- and two-family dwellings in Seismic Design Categories D₀, D₁ and D₂.

R301.2.2.4 masonry construction. Masonry construction shall comply with the requirements of Section R606.12. ~~Masonry construction in Seismic Design Categories D₀ and D₁ shall comply with the requirements of Section R606.12.1. Masonry construction in Seismic Design Category D₂ shall comply with the requirements of Section R606.12.4.~~

R302.3.3.7 Height Limitations. Wood framed buildings shall be limited to three stories above gradeplane or the limits given in Table R602.10.3(3). Cold-formed steel framed buildings shall be limited to less than or equal to three stories above gradeplane in accordance with AISI S230. Mezzanines as defined in Section R202 That comply with Section R 325 shall not be considered as stories. Structural insulated panel buildings shall be limited to two stories above gradeplane.
(Portions of proposal not shown remain unchanged)

Committee Reason: Both of the modifications correct minor errors in the original proposal. The reformatting in this proposal clarifies the seismic requirements of the code.

Assembly Action

None

Final Action Results

RB24-16

AM

[←BACK](#)

Code Change No: **RB160-16**

Original Proposal

Section(s): **R322.3.3, R322.3.4 (New)**

Proponent: Gregory Wilson (gregory.wilson2@fema.dhs.gov); Rebecca Quinn, representing Federal Emergency Management Agency (rcquinn@earthlink.net)

Revise as follows:

R322.3.3 Foundations. Buildings and structures erected in coastal high-hazard areas and Coastal A Zones shall be supported on pilings or columns and shall be adequately anchored to such pilings or columns. The space below the elevated building shall be either free of obstruction or, if enclosed with walls, the walls shall meet the requirements of Section R322.3.4. Pilings shall have adequate soil penetrations to resist the combined wave and wind loads (lateral and uplift). Water-loading values used shall be those associated with the design flood. Wind-loading values shall be those required by this code. Pile embedment shall include consideration of decreased resistance capacity caused by scour of soil strata surrounding the piling. Pile systems design and installation shall be certified in accordance with Section R322.3.6. Spread footing, mat, raft or other foundations that support columns shall not be permitted where soil investigations that are required in accordance with Section R401.4 indicate that soil material under the spread footing, mat, raft or other foundation is subject to scour or erosion from wave-velocity flow conditions. If permitted, spread footing, mat, raft or other foundations that support columns shall be designed in accordance with ASCE 24. ~~Slabs, pools, pool decks and walkways shall be located and constructed to be structurally independent of buildings and structures and their foundations to prevent transfer of flood loads to the buildings and structures during conditions of flooding, scour or erosion from wave-velocity flow conditions, unless the buildings and structures and their foundations are designed to resist the additional flood load.~~

Exception: In Coastal A Zones, stem wall foundations supporting a floor system above and backfilled with soil or gravel to the underside of the floor system shall be permitted provided the foundations are designed to account for wave action, debris impact, erosion and local scour. Where soils are susceptible to erosion and local scour, stem wall foundations shall have deep footings to account for the loss of soil.

Add new text as follows:

R322.3.4 Concrete slabs Concrete slabs used as parking pads, enclosure floors, landings, decks, walkways, patios and similar uses that are located beneath or immediately adjacent to structures shall be designed and constructed in accordance with one of the following:

1. To be structurally independent of the foundation system of the structure, to not transfer flood loads to the main structure, and to be frangible and break away under flood conditions prior to base flood conditions. Reinforcing of concrete slabs, including welded wire reinforcement, shall not be used so as to minimize the potential for concrete slabs being a source of debris. Slabs shall not have turned down edges and slab thickness shall be not more than 4 inches.
2. To be self-supporting, structural slabs capable of remaining intact and functional under base flood conditions, including expected erosion and local scour, and the main structure shall be capable of resisting any added flood loads and effects of local scour due to the presence of the slabs.

Reason: Coastal high hazard areas (Zone V) and Coastal A Zones are portions of flood hazard areas along open shorelines where wave action will occur. Concrete slabs beneath or immediately adjacent to dwellings are affected by flooding, erosion and local scour. The presence of concrete slabs can increase damage to elevated buildings, in part by shifting such that added loads or

increased scour occurs on the building foundation. In the 2015 cycle when a similar proposal was submitted, it was noted that specifications for concrete slabs may be appropriate for Zone V. The IRC now treats Coastal A Zones, if delineated or designated, like Zone V.

This proposal helps clarify what is intended by the requirement in R322.3.3 that the area below elevated buildings shall be free of obstructions. It is based on the requirements of referenced standard ASCE 24-14, Flood Resistant Design and Construction, and best practices documented in several publications issued by the Federal Emergency Management Agency (especially Technical Bulletin 5, Free-of-Obstruction Requirements). The proposed text has two alternatives. One requires concrete slabs in coastal high hazard areas and Coastal A Zones to be frangible (means "easily broken") and to break away under flood conditions. The expectation is this will minimize the size of debris and thus minimize the likelihood of causing significant damage to structures. For many years, many local floodplain management ordinances adopted by coastal communities have used the term "frangible."

The limitation on turned-down edges is based on FEMA's post-disaster field experience that identified damage to foundations when slabs intended to breakaway have turned-down edges which inhibit the slabs from cleanly breaking away when undermined by wave scour or erosion. In Zone V and Coastal A Zones concrete slabs are not permitted to be used as structural foundation elements, thus it is not problematic to limit turned-down edges and thickness for nonstructural slabs used for the stated purposes. The proposal includes an alternative, also based on ASCE 24-14, to have slabs not intended to break away provided the slabs and the adjacent building are designed to resist flood loads.

[note on format – renumber subsequent sections]

Cost Impact: Will not increase the cost of construction

The free of obstruction requirement has been enforced by communities that participate in the National Flood Insurance Program and FEMA guidance has long advised the requirement can be satisfied by requiring concrete slabs to meet the proposed specifications.

Report of Committee Action Hearings

Committee Action:

Approve as Submitted

Committee Reason: The proposed language is unenforceable. In addition, there is no test to determine whether local scour is occurring or not. It is not proper to assume the worst case scenario and require this all across America.

Assembly Action:

None

Public Comments

Public Comment 2:

Gregory Wilson, FEMA, representing Federal Emergency Management Agency (gregory.wilson2@fema.dhs.gov) requests Approve as Modified by this Public Comment.

Modify as follows:

322.3.4 Concrete slabs. Concrete slabs used ~~as for parking pads, enclosure floors of enclosures,~~ landings, decks, walkways, patios and similar uses that are located beneath structures, or immediately adjacent to structures that are located such that if undermined or displaced during base flood conditions the foundations could sustain structural damage, shall be designed and constructed in accordance with one of the following:

- ~~1. To be structurally independent of the foundation system of the structure, to not transfer flood loads to the main structure, and to be frangible and break away under flood conditions prior to base flood conditions. Reinforcing of concrete slabs, including welded wire reinforcement, shall not be used so as to minimize the potential for concrete slabs being a source of debris. Slabs shall not have turned down edges and slab thickness shall be not more than 4 inches.~~
- ~~2. To be self-supporting, structural slabs capable of remaining intact and functional under base flood conditions, including expected erosion and local scour, and the main structure shall be capable of resisting any added flood loads and effects of local scour due to the presence of the slabs.~~
1. To be structurally independent of the foundation system of the structure, to not transfer flood loads to the main structure, and to be frangible and break away under flood conditions prior to base flood conditions. Slabs shall be a maximum of 4 inches in thickness, shall not have turned-down edges, shall not contain reinforcing, shall have isolation joints at pilings and columns, and shall have control or construction joints in both directions spaced not more than 4 feet apart.
2. To be self-supporting, structural slabs capable of remaining intact and functional under base flood conditions, including erosion and local scour, and the main structure shall be capable of resisting any added flood loads and effects of local scour due to the presence of the slabs.

Commenter's Reason: The existing language applies to any and all concrete slabs regardless of location on a site. The original proposal would have narrowed it to slabs beneath buildings and "immediately adjacent" to buildings. Objections to "immediately adjacent" were raised. We considered modifying the proposal to restore the original, applying it to all slabs.

Instead, this public comment replaces it with a performance statement which would require assessment as to whether damage would result if slabs were displaced.

The existing language for concrete slabs, found at the end of Section R322.3.3, already requires consideration of scour for ALL slabs. During deliberation, opposition was expressed about including scour, and yet that was not changed. Plus, after coastal storm FEMA observes damage associated with slabs that do not take into account scour so it is reasonable to account for scour in areas with erodible soils. This proposal has two options. The first is prescriptive – slabs built as specified will break up when undermined by scour and erosion thus site-specific consideration of scour is not required. The second retains the requirement to consider erosion and local scour (removing the word "expected"), which is necessary for slabs to actually function as self-supporting slabs.

Final Action Results

RB160-16

AMPC2

[←BACK](#)

[←BACK](#)

Code Change No: **RB161-16**

Original Proposal

Section(s): **R322.3.6 (New)**

Proponent: Gregory Wilson (gregory.wilson2@fema.dhs.gov); Rebecca Quinn, representing Federal Emergency Management Agency (rcquinn@earthlink.net)

Add new text as follows:

R322.3.6 Stairways and ramps. Stairways and ramps that are located below the lowest floor elevations specified in Section R322.3.2 shall comply with at least one of the following:

1. Be designed and constructed to resist flood loads and minimize transfer of flood loads to the building or structure, including foundation; or
2. Break away during design flood conditions without causing damage to the building or structure, including foundation; or
3. Be retractable, or able to be raised to or above the lowest floor elevation, provided the ability to be retracted or raised prior to the onset of flooding is not contrary to the means of egress requirements of the code.

Reason: Coastal high hazard areas (Zone V) and Coastal A Zones are portions of flood hazard areas along open shorelines where wave action will occur. Stairways and ramp for dwellings are affected by flooding, erosion and scour and the presence of stairways and ramps can increase damage to elevated buildings. In the 2015 cycle when a similar proposal was submitted, it was noted that specifications for stairways and ramps may be appropriate for Zone V. The IRC now treats Coastal A Zones, if delineated or designated, like Zone V.

This proposal helps clarify what is intended by the requirement in R322.3.3 that the area below elevated buildings shall be free of obstructions. It is based on the requirements of referenced standard ASCE 24-14, Flood Resistant Design and Construction and best practices documented in several publications issued by the Federal Emergency Management Agency (especially Technical Bulletin 5, Free-of-Obstruction Requirements). Post-disaster investigations reveal stairways do break away; if properly detailed, they can break away with no significant damage to the remaining building.

ASCE 24 commentary and FEMA guidance advises satisfying the requirement to resist flood-related loads can be best achieved by using railings and treads that are open to the extent allowed by code to facilitate the passage of floodwater. Massive stairs, especially masonry stairs, do not meet the requirement in R322.3.3 that the area below elevated buildings is free of obstruction (obstructions divert waves onto the foundation or adjacent buildings and can exacerbate scour). Ramps should be positioned to avoid alignment with approaching waves, which would allow floodwater to surge up the ramps perhaps even higher than the peak flood elevation, thus flowing into buildings.

Stairways and ramps must be designed to carry normal loads required by the IRC, which must be considered when evaluating the alternative to provide stairways and ramps that are designed to breakaway under flood loads.

Cost Impact: Will not increase the cost of construction

The requirement to avoid obstructions and to have elements below elevated buildings breakaway has been enforced by communities that participate in the NFIP, whether by enforcement of the IRC or local floodplain management regulations. FEMA guidance has long advised the requirement can be satisfied by requiring stairways and ramps to meet the proposed specifications.

Report of Committee Action Hearings

Committee Action:

Approved as Modified

Modify as follows:

R322.3.6 Stairways and ramps. Stairways and ramps that are located below the lowest floor elevations specified in Section R322.3.2 shall comply with at least one of the following:

1. Be designed and constructed with open or partially open risers and railings to allow the free passage of floodwater and waves under the building and structure and to resist flood loads and minimize transfer of flood loads to the building or structure, including foundation; or

2. Break away during design flood conditions without causing damage to the building or structure, including foundation; or
3. Be retractable, or able to be raised to or above the lowest floor elevation, provided the ability to be retracted or raised prior to the onset of flooding is not contrary to the means of egress requirements of the code.

Committee Reason: In the modification, Section R322.3.6 Item 1 went from language that is wide open and vague to something that is concrete, which is very helpful in the code. The proposal adds needed clarity.

Assembly Action:

None

Public Comments

Public Comment 1:

Gary Ehrlich, National Association of Home Builders, representing National Association of Home Builders (gehrlich@nahb.org) requests Approve as Modified by this Public Comment.

Further modify as follows:

R322.3.6 Stairways and ramps. Stairways and ramps that are located below the lowest floor elevations specified in Section R322.3.2 shall comply with at least one of the following:

1. ~~Be designed and constructed with open or partially open risers and railings to allow the free passage of floodwater and waves under the building and structure and to resist flood loads and minimize transfer of flood loads to the building or structure, including foundation guards; or~~
2. ~~Break Stairways and ramps not part of a required means of egress shall be designed and constructed to break away during design flood conditions without causing damage to the building or structure, including foundation; or~~
3. ~~Be retractable, or able to be raised to or above the lowest floor elevation, provided the ability to be retracted or raised prior to the onset of flooding is not contrary to the means of egress requirements of the code; or~~
4. Be designed and constructed to resist flood loads and minimize transfer of flood loads to the building or structure, including foundation.

Areas below stairways and ramps shall not be enclosed with walls below the design flood elevation, unless such walls are constructed in accordance with Section R322.3.4.

Commenter's Reason: The purpose of this public comment is to revise and expand the guidance on stairways and ramps added by this proposal. The original proposal brings over language from ASCE 24-14 into the IRC. However, the ASCE 24 provisions contains two significant flaws. First, the ASCE 24 provisions are written in performance language, whereas the IRC is intended as a prescriptive code. Second, the provisions fall short in bringing forward all of the guidance and recommendations on stairways and ramps available in FEMA TB-5.

NAHB agrees with the concept of constructing stairs with open (or partially open) treads and open guards, as recommended in FEMA TB-5, as one option for dealing with access to and egress from a building in Zone V. While doing so may result in additional costs if the stair needs to be extended to meet the 4" tread height limit, nonetheless open treads and guards are probably the most cost-effective solution for stairs and ramps. The proposal as modified by the committee is amended to separate the prescriptive specification from performance language, introduce the performance language as its own Option #4, and remove commentary language. Code terminology is also corrected ("guards" instead of "railings").

NAHB members building in coastal regions (including Zone V) have expressed concern about ASCE 24 and the IRC and endorsing the construction of a breakaway stair that also acts as the means of egress from the dwelling. Such a stair could potentially fail in a non-flood event, or even in a flood event before occupants have evacuated, presenting a significant life safety issue. FEMA TB-5 hints that breakaway stairs should not be constructed where such stairs would be part of a means of egress. Language similar to that used in R311 (see Sections R311.7.10.2 and R311.7.12 is adapted to modify Option #2 to clarify the point.

Significant damage has occurred to stairs where solid walls extended from the bottom of stair/stringer down to grade. Technically, this would be considered a violation of the "free-of-obstruction" rule under the NFIP, as such construction would not allow the free passage of floodwater and waves under the building and stair. Such enclosures under stairs and ramps are generally discouraged and negatively affect flood insurance rates, but if desired the requirements in IRC Section R322.3.4 for open lattice or breakaway walls must be followed for such construction. A provision is added to clarify this requirement, and would apply regardless of which option or options are selected from the numbered list above.

Final Action Results

RB161-16

AMPC1

[←BACK](#)

[←BACK](#)

Code Change No: **RB162-16**

Original Proposal

Section: R322.3.6 (New)

Proponent: Gregory Wilson (gregory.wilson2@fema.dhs.gov); Rebecca Quinn, representing Federal Emergency Management Agency (rcquinn@earthlink.net)

Add new text as follows:

R322.3.6 Decks and porches. Attached decks and porches shall meet the elevation requirements of Section R322.3.2 and shall either meet the foundation requirements of this section or shall be cantilevered from or knee braced to the building or structure. Self-supporting decks and porches that are below the elevation required in Section R322.3.2 shall not be enclosed by solid, rigid walls, including walls designed to break away. Self-supporting decks and porches shall be designed and constructed to remain in place during base flood conditions or shall be frangible and break away under base flood conditions.

Reason: Coastal high hazard areas (Zone V) and Coastal A Zones are portions of flood hazard areas along open shorelines where wave action will occur. Decks and porches attached to or adjacent to dwellings are affected by flooding, erosion and scour. The presence of decks and porches can increase damage to elevated buildings unless they are constructed in ways intended to minimize damage. In the 2015 cycle when a similar proposal was submitted, it was noted that specifications for decks and porches may be appropriate for Zone V. The IRC now treats Coastal A Zones, if delineated or designated, like Zone V.

This proposal clarifies how decks and porches are treated and is based on the requirements of referenced standard ASCE 24-14, Flood Resistant Design and Construction and best practices documented in several publications issued by the Federal Emergency Management Agency (especially Technical Bulletin 5, Free-of-Obstruction Requirements). Attached decks must be at or above the same elevation as dwellings because they are, in effect, extensions of the dwellings. Also, if attached and lower than the elevation of a dwelling, a deck or porch would be an obstruction and thus not permitted by the free-of-obstruction requirement in R322.3.3.

Self-supporting decks and porches are separate structures. If permitted below the elevation required for dwellings, they must not be enclosed by walls because decks enclosed with walls are buildings that must meet all requirements for buildings in flood hazard areas. Whether self-supporting decks and porches are elevated or below the require elevation, they must either be designed to resist flood loads or to break away under flood and wave conditions associated with the base flood. The term frangible means "easily broken," the expectation is this will minimize the size of debris and thus minimize the likelihood of causing significant damage to structures by the presence of water-borne debris. For many years, many local floodplain management ordinances adopted by coastal communities have used the term "frangible."

Cost Impact: Will not increase the cost of construction

The elevation requirement and free of obstruction requirement have been enforced by communities that participate in the National Flood Insurance Program and FEMA guidance has long advised the requirement can be satisfied by requiring decks and porches to meet the proposed specifications.

Report of Committee Action Hearings

Committee Action:

Approved as Submitted

Committee Reason: This proposal gives better guidance regarding decks and porches.

Assembly Action:

None

Final Action Results

RB162-16

AS

Code Change No: **RB164-16**

Original Proposal

Section: R324.3, R324.3.1, R324.4, R324.4.1, R324.5, R324.5.1, R324.5.2 (New), R907, R907.1, R907.2, R907.3, R907.4, R907.5, R909, R909.1, R909.2, R909.3

Proponent: Joseph Cain, SunEdison, representing Solar Energy Industries Association (SEIA) (joecainpe@aol.com); Edward Kulik, representing Building Code Action Committee (bcac@iccsafe.org)

Revise as follows:

R324.3 Photovoltaic systems. Photovoltaic systems shall be designed and installed in accordance with Sections R324.3.1 through ~~R324.6.1 and R324.5.2.5~~, NFPA 70. ~~Inverters shall be listed and labeled in accordance with UL 1741. Systems connected to the utility grid shall use inverters listed for utility interaction manufacturers installation instructions.~~

R324.3.1 Equipment listings. Photovoltaic panels and modules shall be listed and labeled in accordance with UL 1703. Inverters shall be listed and labeled in accordance with UL 1741. Systems connected to the utility grid shall use inverters listed for utility interaction.

R324.4 Rooftop-mounted photovoltaic systems. Rooftop-mounted ~~photovoltaic panel systems~~ photovoltaic panel systems installed on or above the roof covering shall be designed and installed in accordance with ~~Section R907~~ this section.

~~R909.2~~ **R324.4.1 Structural requirements.** Rooftop-mounted ~~photovoltaic panel systems~~ photovoltaic panel systems shall be designed to structurally support the system and withstand applicable gravity loads in accordance with Chapter 3. The roof upon which these systems are installed shall be designed and constructed to support the loads imposed by such systems in accordance with Chapter 8.

~~R324.4.1~~ **R324.4.1.1 Roof live load.** *No change to text.*

~~R907.2~~ **R324.4.1.2 Wind resistance.** *No change to text.*

~~R907.3~~ **R324.4.2 Fire classification.** Rooftop-mounted ~~photovoltaic panels or modules~~ photovoltaic panel systems shall have the same fire classification as the roof assembly required in Section R902.

~~R909.3~~ **R324.4.3 Installation-Roof penetrations.** ~~Rooftop-mounted photovoltaic systems shall be installed in accordance with the manufacturer's instructions.~~ Roof penetrations shall be flashed and sealed in accordance with ~~this chapter~~ Chapter 9.

R324.5 Building-integrated photovoltaic systems. Building-integrated photovoltaic systems that serve as roof coverings shall be designed and installed in accordance with Section R905.

R324.5.1 Photovoltaic shingles. Photovoltaic shingles shall comply with Section R905.16.

Add new text as follows:

R324.5.2 Fire classification. Building-integrated photovoltaic systems shall have a fire classification in accordance with Section 902.3.

Revise as follows:

**SECTION R907
ROOFTOP-MOUNTED PHOTOVOLTAIC PANEL SYSTEMS**

R907.1 Rooftop-mounted photovoltaic panel systems. Rooftop-mounted photovoltaic panels or modules ~~photovoltaic panel systems~~ shall be designed and installed in accordance with ~~this section,~~ Section R324 and NFPA 70.

Delete without substitution:

~~**R907.4 Installation.** Rooftop-mounted photovoltaic panels or modules shall be installed in accordance with the manufacturer's instructions.~~

~~**R907.5 Photovoltaic panels and modules.** Rooftop-mounted photovoltaic panels and modules shall be listed and labeled in accordance with UL 1703 and shall be installed in accordance with the manufacturer's printed instructions.~~

~~**SECTION R909
ROOFTOP-MOUNTED PHOTOVOLTAIC PANEL SYSTEMS**~~

~~**R909.1 General.** The installation of photovoltaic panel systems that are mounted on or above the roof covering shall comply with this section, Section R324 and NFPA 70.~~

Reason: Proposal RM98-13 established R324, which was intended to consolidate and organize all the requirements, with necessary section revisions and section additions, in an easily-used format that assists the user to find all the applicable requirements – fire, electrical, structural, plumbing, and mechanical – related to solar thermal and photovoltaic systems. The intent of this proposal is to address redundant code requirements and consolidate/reorganize requirements that were also included in Chapter 9 during the last code cycle. These changes will help to address any confusion regarding the installation of photovoltaic systems.

The following explains the changes proposed:

1. Load requirements for rooftop mounted photovoltaic system installations are partially covered in R907.2 and R324.4.1. Relocating R907.2 to be a subsection of R324.4 consolidates the load requirements. The structural requirements (Section R909.2) are relocated to be a subsection of R324.4.
2. Fire classification requirements (Section R907.3) are for rooftop mounted photovoltaic systems, not rooftop mounted photovoltaic panels and modules, and are referenced in Section R324.4.2. The fire classification requirements for building-integrated photovoltaic systems are not linked in Section R324 or R905.16 (see new Section R324.5.2).
3. Installation in accordance with the manufacturer's installation instructions (Sections R907.4 and R907.5 and R909.3) are consolidated into Section R324.3.
4. Listed and labeled rooftop mounted panels and modules (Section 907.5) is already required by Section R324.3.1.
5. Two separate sections (Section 907 and 909) are not needed for rooftop-mounted photovoltaic panel systems.
6. Flashing of roof penetrations for rooftop-mounted photovoltaic systems (Section R909.3) is addressed in Section R324.4.3.
7. Equipment listing requirements relocated from Section R324.3 to R324.3.1 to consolidate in one location these requirements.

The ICC Building Code Action Committee (BCAC) is a co-proponent of this proposal. BCAC was established by the ICC Board of Directors to pursue opportunities to improve and enhance assigned International Codes or portions thereof. In 2014 and 2015 the BCAC has held 5 open meetings. In addition, there were numerous Working Group meetings and conference calls for the current code development cycle, which included members of the committee as well as any interested party to discuss and debate the proposed changes. Related documentation and reports are posted on the BCAC website at: [BCAC](#)

Cost Impact: Will not increase the cost of construction
The proposal clarifies the applicable requirements for photovoltaic systems.

**Report of Committee Action
Hearings**

Committee Action:

Approved as Submitted

Committee Reason: This proposal correlates and organizes the provisions in the code.

Assembly Action:

None

Final Action Results

RB164-16

AS

[←BACK](#)

[←BACK](#)

Code Change No: **RB165-16**

Original Proposal

Section: R324.4.1

Proponent: Jonathan Siu, City of Seattle Department of Construction & Inspections, representing Washington Association of Building Officials Technical Code Development Committee (jon.siu@seattle.gov)

Delete and substitute as follows:

~~**R324.4.1 Roof live load.** Roof structures that provide support for photovoltaic panel systems shall be designed for applicable roof live load. The design of roof structures need not include roof live load in the areas covered by photovoltaic panel systems. Portions of roof structures not covered by photovoltaic panels shall be designed for roof live load. Roof structures that provide support for photovoltaic panel systems shall be designed for live load, LR, for the load case where the photovoltaic panel system is not present.~~

Portions of roof structures not covered with photovoltaic panel systems shall be designed for dead loads and roof loads in accordance with Sections R301.4 and R301.6. Portions of roof structures covered with photovoltaic panel systems shall be designed for the following load cases:

1. Dead load (including photovoltaic panel weight) plus snow load in accordance with Table R301.2(1).
2. Dead load (excluding photovoltaic panel weight) plus roof live load or snow load, whichever is greater, in accordance with Section R301.6.

Reason: This proposal is intended to clarify and correct the requirements for design loads for roofs with PV panels. The current code text is confusing, incomplete, and technically incorrect.

- The text is confusing because the fourth sentence appears to contradict the second sentence. In addition, the term L_r is not used in the IRC so it is unclear how this is to be applied.
- The text is incomplete because it does not appear to include snow load on top of the PV panels as a load case for roof design.
- The text is technically incorrect because it implies the PV panels themselves would be considered as live load. This is inconsistent with how ASCE 7 and other portions of the IRC treat fixed equipment (see Section R301.4 and the definition of "Dead Load" in Section R202).

We believe the proposed code change more clearly and completely states the intended requirement.

It is to be noted that Section R324.4 does not contain the wind load requirement for PV panels, although it references Section R907, which does. A separate code change proposal will move Section 907.2 to this section so the requirement will not get missed.

Cost Impact: Will not increase the cost of construction

This proposal merely clarifies how loads are to be applied to the roof structure. Properly-designed roof structures should have been using the load cases in this proposal, so no change in cost or construction is anticipated.

Report of Committee Action Hearings

Committee Action:

Approved as Submitted

Committee Reason: The committee approved this proposal based on the proponents published reason statement. The committee felt this change provides good clarification of the design loads for roofs supporting photovoltaic panel systems.

Assembly Action:

None

Final Action Results

RB165-16

AS

[←BACK](#)

[←BACK](#)

Code Change No: **RB172-16**

Original Proposal

Section: R202 (New), R401.4, R801.3

Proponent: Woodward Vogt, Paradigm Consultants, Inc., representing GeoCoalition (woody@paradigmconsultants.com); Lori Simpson, P.E., G.E., representing GeoCoalition

Add new definition as follows:

COLLAPSIBLE SOILS. Soils that exhibit volumetric reduction in response to partial or full wetting under load.

COMPRESSIBLE SOILS Soils that exhibit volumetric reduction in response to the application of load even in the absence of wetting or drying.

EXPANSIVE SOILS. Soils that exhibit volumetric increase or decrease (swelling or shrinking) in response to partial or full wetting or drying under load.

Revise as follows:

R401.4 Soil tests. Where quantifiable data created by accepted soil science methodologies indicate *expansive soils*, *compressible soils*, shifting or other questionable soil characteristics are likely to be present, the *building official* shall determine whether to require a soil test to determine the soil's characteristics at a particular location. This test shall be done by an *approved agency* using an *approved* method.

R801.3 Roof drainage. In areas where *expansive soils* or *collapsible soils* are known to exist, all *dwellings* shall have a controlled method of water disposal from roofs that will collect and discharge roof drainage to the ground surface not less than 5 feet (1524 mm) from foundation walls or to an *approved* drainage system.

Reason: [Click here to view the members of the GeoCoalition who developed this proposal.](#)

There is currently no definition for collapsible soils to provide guidance to design professionals and building officials on identification and design procedures to address these soils. These terms are used in IRC Section R401.4 and R801.3.

Cost Impact: Will not increase the cost of construction

The change is for clarification so there is not change to construction requirements.

Report of Committee Action Hearings

Committee Action:

Approved as Submitted

Committee Reason: This proposal adds needed definitions for these soils and provides clarification to the code text.

Assembly Action:

None

Final Action Results

RB172-16

AS

Code Change No: **RB173-16**

Original Proposal

Section: R401.2

Proponent: Paul Helderman, Superior Walls of America, representing Superior Walls of America (ehelderman@superiorwalls.com)

Revise as follows:

R401.2 Requirements. Foundation construction shall be capable of accommodating all loads in accordance with Section R301 and of transmitting the resulting loads to the supporting soil. Fill soils that support footings and foundations shall be designed, installed and tested in accordance with accepted engineering practice. ~~Gravel fill used as footings for wood and precast concrete foundations shall comply with Section R403.~~

Reason: The recommendation is to eliminate the last sentence from Section R401.2 for the following reasons:

1. It is superfluous to say that something used for footings must comply with the Section on Footings.
2. The term "Gravel fill" is not used to describe footings for precast concrete foundations.
3. Fill is fill and footings are footings; it is confusing to interchange the terms.
4. Per Section R403.3.1 crushed stone footings for precast concrete foundations are to be "angular" in nature and meet ASTM C33; "gravel" does not meet this requirement.

Cost Impact: Will not increase the cost of construction

This proposal will not increase the cost of construction because it merely seeks to provide clarification and eliminates superfluous language without changing the technical requirements of the code.

Report of Committee Action Hearings

Committee Action:

Approved as Submitted

Committee Reason: This change removes the term gravel fill which is technically incorrect and eliminates confusion. Also based on the proponents published reason statement.

Assembly Action:

None

Final Action Results

RB173-16

AS

[←BACK](#)

Code Change No: **RB176-16**

Original Proposal

Section: R403.1.1

Proponent: Paul Helderman, Superior Walls of America, representing Superior Walls of America (ehelderman@superiorwalls.com)

Revise as follows:

R403.1.1 Minimum size. The minimum width, W, and thickness, T, for concrete footings shall be in accordance with Tables R403.1(1) through R403.1(3) and Figure R403.1(1) or R403.1.3, as applicable. The footing width shall be based on the load-bearing value of the soil in accordance with Table R401.4.1. Footing projections, P, shall be not less than 2 inches (51 mm) and shall not exceed the thickness of the footing. Footing thickness and projection for fireplaces shall be in accordance with Section R1001.2. The size of footings supporting piers and columns shall be based on the tributary load and allowable soil pressure in accordance with Table R401.4.1. Footings for wood foundations shall be in accordance with the details set forth in Section R403.2, and Figures R403.1(2) and R403.1(3). Footings for precast foundations shall be in accordance with the details set forth in Section R403.4, Table R403.4, and Figures R403.4(1) and R403.4(2).

Reason: A previous proposal (RB211-13) changed the language of Section R403.1.1 and replaced Table R403.1 with 3 new tables, which appeared in the 2015 IRC code. Because of that code change, the previous reference and association to precast was eliminated from that table heading in Table R403.1, but this section still needs to point the reader to section R403.4 for instructions for constructing footings for precast foundations.

This proposal simply adds one sentence to section R403.1.1 that points the reader to the precast footing section (Section R403.4) for instructions on constructing footings for precast.

To conform with existing code language, the new sentence about constructing footings for precast is modeled exactly the same as other language in this paragraph that points the reader to Section R403.2 about constructing footings for wood foundations.

Cost Impact: Will not increase the cost of construction

This proposal will not increase the cost of construction because it only seeks to provide clarification by restoring a reference to precast footings that was lost in a previous code change. This proposal is not changing the technical requirements of the code.

Report of Committee Action Hearings

Committee Action:

Approved as Submitted

Committee Reason: The committee approved this proposal based on the proponents published reason statement. Also, this change provides the proper reference to the correct footing table

Assembly Action:

None

Final Action Results

RB176-16

AS

Code Change No: **RB177-16**

Original Proposal

Section: R403.1.6

Proponent: Jon-Paul Cardin, American Iron and Steel Institute, representing American Iron and Steel Institute (JCardin@steel.org)

Revise as follows:

R403.1.6 Foundation anchorage. Wood sill plates and wood walls supported directly on continuous foundations shall be anchored to the foundation in accordance with this section.

Cold-formed steel framing shall be anchored directly to the foundation or fastened to wood sill plates ~~anchored to the foundation in accordance with Section R505.3.1 or R603.3.1, as applicable.~~ Anchorage of cold-formed steel framing and Wood sill plates supporting cold-formed steel framing shall be anchored to the foundation in accordance with this section ~~and Section R505.3.1 or R603.3.1.~~

Wood sole plates at all exterior walls on monolithic slabs, wood sole plates of *braced wall panels* at building interiors on monolithic slabs and all wood sill plates shall be anchored to the foundation with minimum 1/2-inch- diameter (12.7 mm) anchor bolts spaced a maximum of 6 feet (1829 mm) on center or *approved* anchors or anchor straps spaced as required to provide equivalent anchorage to 1/2-inch-diameter (12.7 mm) anchor bolts. Bolts shall extend a minimum of 7 inches (178 mm) into concrete or grouted cells of concrete masonry units. The bolts shall be located in the middle third of the width of the plate. A nut and washer shall be tightened on each anchor bolt. There shall be a minimum of two bolts per plate section with one bolt located not more than 12 inches (305 mm) or less than seven bolt diameters from each end of the plate section. Interior bearing wall sole plates on monolithic slab foundation that are not part of a *braced wall panel* shall be positively anchored with *approved* fasteners. Sill plates and sole plates shall be protected against decay and termites where required by Sections R317 and R318.

Exceptions:

1. Walls 24 inches (610 mm) total length or shorter connecting offset braced wall panels shall be anchored to the foundation with a minimum of one anchor bolt located in the center third of the plate section and shall be attached to adjacent braced wall panels at corners as shown in Item 9 of Table R602.3(1).
2. Connection of walls 12 inches (305 mm) total length or shorter connecting offset *braced wall panels* to the foundation without anchor bolts shall be permitted. The wall shall be attached to adjacent braced wall panels at corners as shown in Item 9 of Table R602.3(1).

Reason: This proposed revision is an editorial change intended to clarify the anchorage requirements for cold-formed steel wall assemblies. The referenced sections (R505.3.1 and R603.3.1) cover the anchorage requirements for cold-formed steel directly to the foundation or to the wood sill plate. The connection of the wood sill plate (that supports the CFS) to the foundation is intended to conform to this section.

Cost Impact: Will not increase the cost of construction
This is simply a proposed editorial change that does not effect the intended prescribed construction requirements.

**Report of Committee Action
Hearings**

Committee Action:

Approved as Submitted

Committee Reason: The committee approved this change based on the proponents published reason statement. The change clarifies the anchorage of cold-formed steel framing with wood sill plates.

Assembly Action:

None

Final Action Results

RB177-16

AS

[←BACK](#)

[←BACK](#)

Code Change No: RB178-16

Original Proposal

Section: R403.4

Proponent: Paul Helderman, Superior Walls of America, representing Superior Walls of America (ehelderman@superiorwalls.com)

Revise as follows:

TABLE R403.4
MINIMUM DEPTH AND WIDTH OF CRUSHED STONE FOOTINGS^a (D AND W), (inches)

NUMBER OF STORIES	UNIFORM WALL LOAD	LOAD-BEARING VALUE OF SOIL (psf)																													
		1500						2000						2500			3000						3500			4000					
		MH, CH, CL, ML						SC, GC, SM, GM, SP, SW									GP, GW														
		Wall width (inches)						Wall width (inches)						Wall width (inches)			Wall width (inches)						Wall width (inches)			Wall width (inches)					
		6	8	10	12	6	8	10	12	8	10	12	6	8	10	12	8	10	12	6	8	10	12	6	8	10	12				
Conventional light-frame construction																															
1-story	1100 plf	D	6	4	4	4	6	4	4	4	4	4	4	4	6	4	4	4	4	4	4	6	4	4	4	4					
		W	-	13	15	17	-	13	15	17	13	15	17	-	13	15	17	13	15	17	-	13	15	17	-	13	15	17			
2-story	1800 plf	D	8	6	4	4	6	4	4	4	4	4	4	6	4	4	4	4	4	4	6	4	4	4	4	4					
		W	-	15	15	17	-	13	15	17	13	15	17	-	13	15	17	13	15	17	-	13	15	17	-	13	15	17			
3-story	2900 plf	D	4	14	12	10	4	8	6	6	6	4	4	6	4	4	4	4	4	4	6	4	4	4	4	4					
		W	-	25	24	24	-	19	19	18	15	15	17	-	13	15	17	13	15	17	-	13	15	17	-	13	15	17			
4-inch brick veneer over light-frame or 8-inch hollow concrete masonry																															
1-story	1500 plf	D	6	4	4	4	6	4	4	4	4	4	4	6	4	4	4	4	4	4	6	4	4	4	4	4					
		W	-	13	15	17	-	13	15	17	13	15	17	-	13	15	17	13	15	17	-	13	15	17	-	13	15	17			
2-story	2700 plf	D	4	12	10	8	4	8	6	4	5	4	4	6	4	4	4	4	4	4	6	4	4	4	4	4					
		W	-	22	23	23	-	18	17	17	14	15	17	-	13	15	17	13	15	17	-	13	15	17	-	13	15	17			
3-story	4000 plf	D	2	22	20	18	4	14	12	10	10	8	7	4	8	6	4	5	4	4	6	4	4	4	4	4					
		W	-	33	34	33	-	25	26	25	20	20	21	-	17	17	17	14	15	17	-	13	15	17	-	13	15	17			
8-inch solid or fully grouted masonry																															

1-story	2000 plf	D	4	87	6	4	6	4	4	4	4	4	6	4	4	4	4	4	6	4	4	4		
		W	-	17	17	17	-	13	15	17	13	15	17	-	13	15	17	13	15	17	-	13	15	17
2-story	3600 plf	D	2	181	161	161	4	12	191	89	9	7	5	8	6	4	4	4	4	6	4	4	4	
		W	-	30	30	30	-	22	23	23	19	19	18	-	15	15	17	13	15	17	-	13	15	17
3-story	5300 plf	D	3	30	282	262	2	222	201	18	16	14	12	4	12	10	8	9	8	6	4	87	6	4
		W	-	43	44	44	-	33	32	33	27	27	26	-	22	22	22	19	20	19	-	17	17	17

For SI: 1 inch = 25.4 mm, 1 plf = 14.6 N/m, 1 pound per square foot = 47.9 N/m².

- Linear interpolation of stone depth between wall widths is permitted within each Load-Bearing Value of Soil (psf).
- Crushed stone must be consolidated in 8" lifts with a plate vibrator.

Reason: This proposal changes this table to include both the depth (D) and width (W) as is already shown in figure R403.4(1). This table (Table R403.4 Minimum Depth of Crushed Stone Footings) only provides the Depth (D) in inches of crushed stone footings for precast, but the Width (W) is also needed to fully describe a crushed stone footing and how it spreads the load of the precast concrete wall into the soil. The table has never contained any references to the footing width, but it has always been included in its companion drawing [Figure R403.4(1)], so it is important that this information be included in the table also. To fall in line with the concrete footing tables R403.1(1), R403.1(2) and R403.1(3), which are referred to in section R403.1.1, two additional soil PSF categories have also been added to Table R403.4.

Footnote b. was added at the bottom of the table to reinforce the necessity to compact crushed stone footings in lifts of 8" as is stated in the text of Section R403.4.1 Crushed stone footings.

Cost Impact: Will not increase the cost of construction

This proposal will not increase the cost of construction because the changes to this table do not increase the average amount of crushed stone that is typically used for footings to support precast foundations. It is already standard practice for builders and precast foundation manufacturers to include crushed stone footing widths (W) wider than the maximum widths (W) that are required in the table. Stone depths and widths in the table are minimums and in the field, these depths and widths are usually over estimated to assure minimums are easily met.

The width dimension (W) has been added to the table to prevent anyone from overlooking this important minimum dimension of a crushed stone footing.

When recalculating all of the depths for the table, some of the crushed stone footing depths (D) also change by 1 inch, some increased and some decreased, but the changes are negligible and it will not increase the cost of construction.

Report of Committee Action Hearings

Committee Action:

Approved as Submitted

Committee Reason: The proposal updates the crushed stone footing table to include the width and adds additional soil bearing capacities to match the concrete footing tables.

Assembly Action:

None

Final Action Results

RB178-16

AS

[←BACK](#)

Code Change No: RB179-16

Original Proposal

Section: R403.3

Proponent: John Woestman, Kellen, representing Extruded Polystyrene Foam Association (jwoestman@kellencompany.com)

Revise as follows:

TABLE R403.3 (1)
MINIMUM FOOTING DEPTH AND INSULATION REQUIREMENTS FOR FROST-PROTECTED FOOTINGS IN HEATED BUILDINGS^a

AIR FREEZING INDEX (°F-days) ^b	MINIMUM FOOTING DEPTH, D (inches)	VERTICAL INSULATION R-VALUE ^{c, d}	HORIZONTAL INSULATION R-VALUE ^{c, e}		HORIZONTAL INSULATION DIMENSIONS PER FIGURE R403.3(1) (inches)		
			Along walls	At corners	A	B	C
1,500 or less	12	4.5	Not required	Not required	Not required	Not required	Not required
2,000	14	5.6	Not required	Not required	Not required	Not required	Not required
2,500	16	6.7	1.7	4.9	12	24	40
3,000	16	7.8	6.5	8.6	12	24	40
3,500	16	9.0	8.0	11.2	24	30	60
4,000	16	10.1	10.5	13.1	24	36	60

For SI: 1 inch = 25.4 mm, °C = [(°F) - 32]/1.8.

- a. Insulation requirements are for protection against frost damage in heated buildings. Greater values may be required to meet energy conservation standards.
- b. See Figure R403.3(2) or Table R403.3(2) for Air Freezing Index values.
- c. Insulation materials shall provide the stated minimum ~~R-values~~ R-values under long-term exposure to moist, below-ground conditions in freezing climates. The following ~~R-values~~ R-values shall be used to determine insulation thicknesses required for this application: Type II expanded polystyrene ~~2.4 R polystyrene~~ (EPS)-3.2R per inch; Type IV ~~extruded polystyrene 4.5 R for vertical insulation and 2.6R per inch; Type VI extruded polystyrene 4.5 R per inch for horizontal insulation;~~ Type IX expanded polystyrene ~~3.2 R polystyrene~~ (EPS)-3.4R per inch for vertical insulation and 2.8R per inch for horizontal insulation; Type IV, V, VI, VII, and X ~~extruded polystyrene 4.5 R polystyrene~~ (XPS)-4.5R per inch for vertical insulation and 4.0R per inch for horizontal insulation.
- d. Vertical insulation shall be expanded polystyrene insulation or extruded polystyrene insulation.
- e. Horizontal insulation shall be expanded polystyrene insulation or extruded polystyrene insulation.

Reason: This proposal updates the IRC to be consistent with the latest published design values for insulation materials used on frost-protected shallow foundations (FPSF), per ASCE 32-01 Design and Construction of Frost-Protected Shallow Foundations; and to be consistent with the current requirements in the IBC.

The IBC in Section 1809.5, requires foundations to be protected from frost by one or more methods, with item 2 of 1809.5 stating: "Constructing in accordance with ASCE 32." ASCE 32-01 is identified in Chapter 35 Reference Standards of the IBC Copied below is information from mandatory Appendix A of ASCE 32-01:

TABLE A1. Design Values for FPSF Insulation Materials

Insulation Type per ASTM C578	Minimum Insulation Density per ASTM C578 (pcf)	Effective Resistivity, r_{eff} ¹ (R per Inch)		Nominal Resistivity per ASTM C578 (R per inch)	Allowable Bearing Capacity ² (psf)	Minimum Insulation Thickness (inches)	
		Vertical	Horizontal			Vertical	Horizontal
Expanded Polystyrene							
Type II	1.35	3.2	2.6	4.0	N/A	2	3
Type IX	1.8	3.4	2.8	4.2	1,200	1.5	2
Extruded Polystyrene							
Type X	1.35	4.5	4.0	5.0	N/A	1.5	2
Type IV	1.6	4.5	4.0	5.0	1,200	1	1.5
Type VI	1.8	4.5	4.0	5.0	1,920	1	1
Type VII	2.2	4.5	4.0	5.0	2,880	1	1
Type V	3.0	4.5	4.0	5.0	4,800	1	1

¹ Effective resistivity is based on tests from laboratory and field studies of insulation products under long-term exposure to moist, below-ground conditions. 'Vertical' effective resistivity shall be used for insulation placed vertically on exterior foundation walls. 'Horizontal' effective resistivity shall be used for insulation placed horizontally, below ground.

² Allowable bearing capacity is based on ASTM C578 compressive strength at 10% deformation divided by a safety factor of 3.0 for conditions without cyclic loading (i.e., highway vehicle loading).

'N/A' prohibits use where structural foundation loads are supported (i.e., insulation below footings).

Cost Impact: Will increase the cost of construction

Depending on the project's design, this proposal may increase the cost of construction, as the design values for below-grade EPS and XPS are revised by this proposal. For most vertical applications, slightly less EPS or XPS will be needed to achieve the required thermal performance. For most horizontal applications, slightly more EPS or XPS will be needed.

Report of Committee Action Hearings

Committee Action:

Approved as Submitted

Committee Reason: The committee approved this change based on the proponents published reason statement. The change aligns the insulation types with ASCE 32 and the IBC.

Assembly Action:

None

Final Action Results

RB179-16

AS

[←BACK](#)

Code Change No: RB181-16

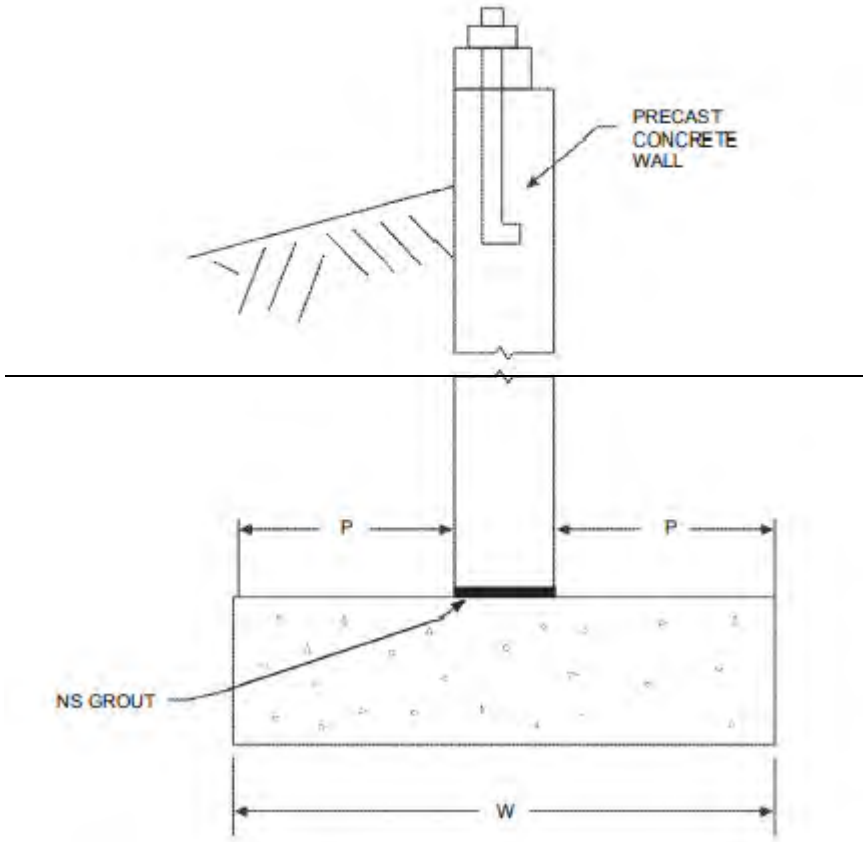
Original Proposal

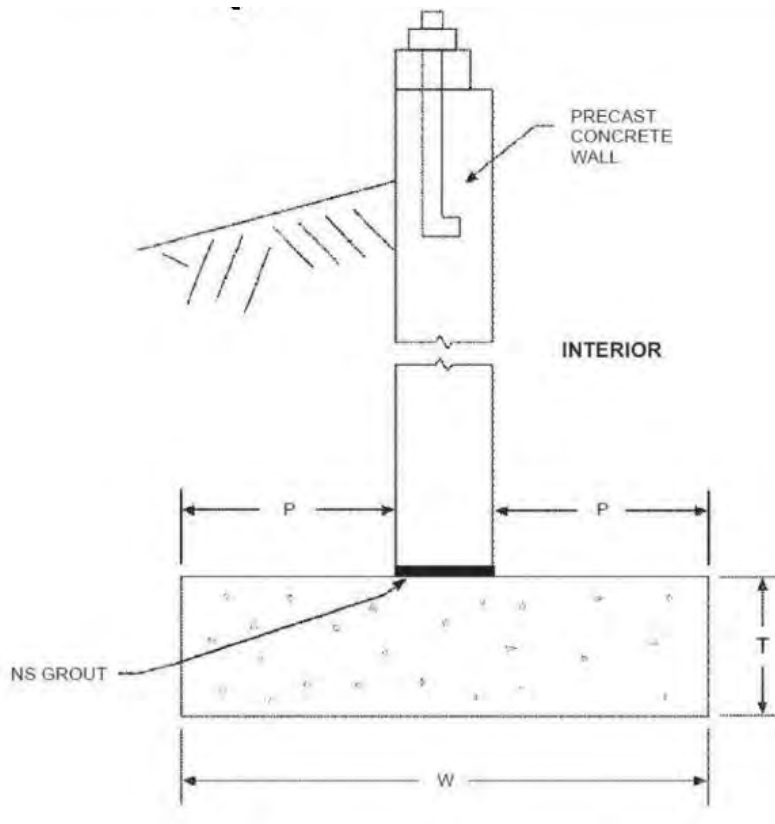
Section: R403.4

Proponent: Paul Helderman, Superior Walls of America, representing Superior Walls of America (ehelderman@superiorwalls.com)

Revise as follows:

**FIGURE R403.4 (2)
BASEMENT OR CRAWL SPACE WITH PRECAST FOUNDATION WALL ON SPREAD FOOTING**





Reason: Figure R403.4(2) is depicting a (non-descript) precast foundation sitting on a concrete spread footing. To fall in step with section R403.1.1, which describes the minimum size requirements for concrete footings, dimension T for "footing thickness" needs to be added to Figure R403.4(2) so dimension T is correctly illustrated. The corrected illustration adds the T dimension to Figure R403.4(2).

Figure R403.4(2) is also inaccurate in the sense that it does not depict a typical sill plate connection to a precast foundation wall. While there are many possible methods of connecting a sill plate to a precast concrete foundation wall panel this is not one that is commonly used if it is ever used at all. A more accurate representation is needed. This new drawing of Figure R403.4(2) also more accurately represents one type of sill plate connection to a precast concrete foundation wall that is commonly used in the precast industry, while it still remains non-proprietary in nature.

This change does not require any more space in the code book but simply improves an existing illustration so it is more accurate.

Cost Impact: Will not increase the cost of construction

This proposal will not increase the cost of construction.

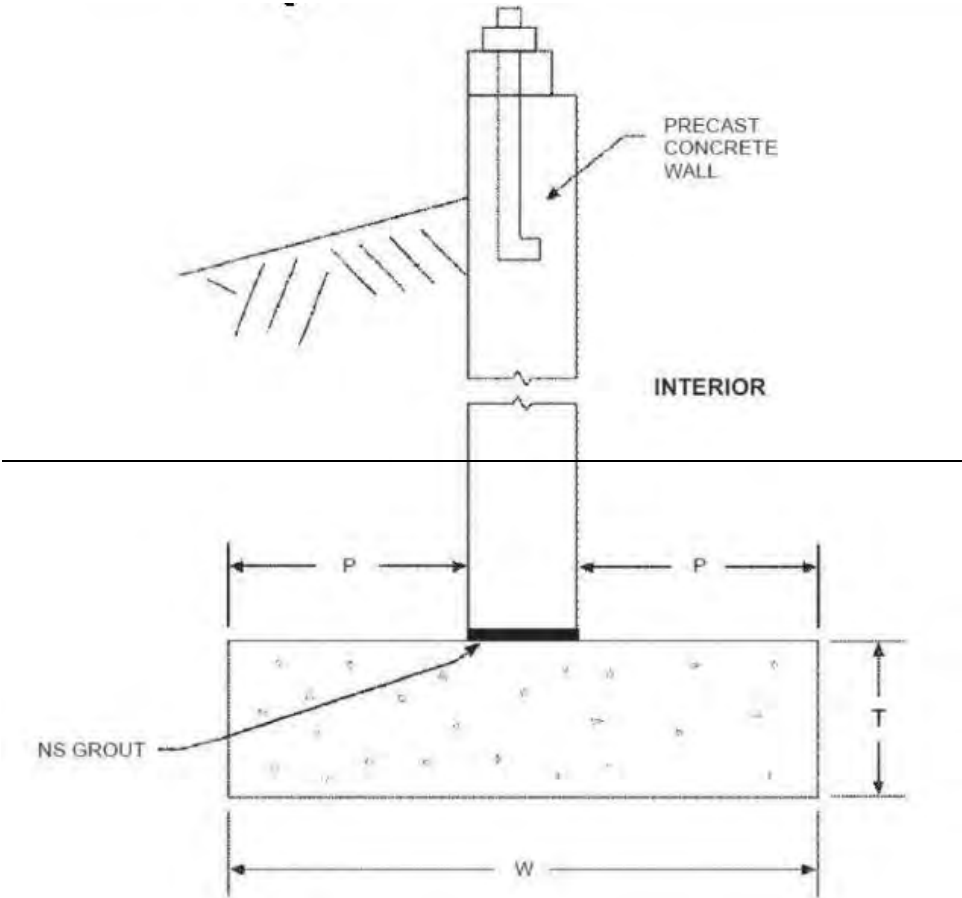
This proposal is NOT changing the technical requirements of the code, it is just clarifying the code by representing a more realistic sill plate connection for a precast foundation and it is adding the thickness (T) dimension, which is currently missing from the figure 403.4(2). Concrete footing requirements remain the same.

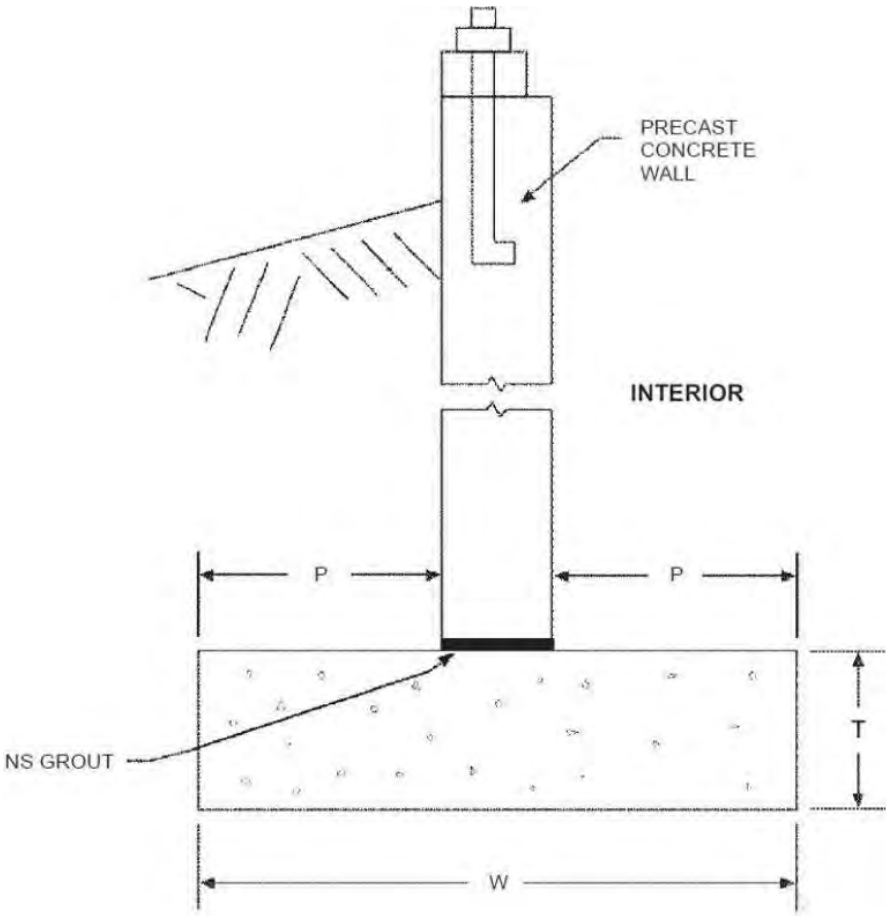
Report of Committee Action Hearings

Committee Action:

Approved as Modified

Modify as follows:





Committee Reason: This proposal updates the figure to add the dimension T for the footing thickness. The modification reverts the figure to the original with dimension T added. The proposed figure was too restrictive.

Assembly Action

None

Final Action Results

RB181-16

AM

[←BACK](#)

[←BACK](#)

Code Change No: **RB184-16**

Original Proposal

Section: R405.1

Proponent: William Miller, Senior Building Inspector, County of Warren, representing County of Warren, VA (wmiller@warrencountyva.net)

Revise as follows:

R405.1 Concrete or masonry foundations. Drains shall be provided around concrete or masonry foundations that retain earth and enclose habitable or usable spaces located below *grade*. Drainage tiles, gravel or crushed stone drains, perforated pipe or other *approved* systems or materials shall be installed at or below the ~~area to be protected~~ top of the footing or below the bottom of the slab and shall discharge by gravity or mechanical means into an *approved* drainage system. Gravel or crushed stone drains shall extend not less than 1 foot (305 mm) beyond the outside edge of the footing and 6 inches (152 mm) above the top of the footing and be covered with an *approved* filter membrane material. The top of open joints of drain tiles shall be protected with strips of building paper. Except where otherwise recommended by the drain manufacturer, perforated drains shall be surrounded with an *approved* filter membrane or the filter membrane shall cover the washed gravel or crushed rock covering the drain. Drainage tiles or perforated pipe shall be placed on a minimum of 2 inches (51 mm) of washed gravel or crushed rock not less than one sieve size larger than the tile joint opening or perforation and covered with not less than 6 inches (152 mm) of the same material.

Exception: A drainage system is not required where the foundation is installed on well-drained ground or sand-gravel mixture soils according to the Unified Soil Classification System, Group I soils, as detailed in Table R405.1.

Reason: "area to be protected" is unclear and should be specified in the code. Placing drain tile too high is a primary cause of leaking basements.

Cost Impact: Will not increase the cost of construction
There is no cost increase. Material & labor should be the same.

Report of Committee Action Hearings

Committee Action:

Approved as Submitted

Committee Reason: The committee approved this proposal based on the proponents published reason statement.

Assembly Action:

None

Final Action Results

RB184-16

AS

[←BACK](#)

[←BACK](#)

Code Change No: **RB187-16**

Original Proposal

Section: R408.3

Proponent: Craig Conner, representing self (craig.conner@mac.com)

Revise as follows:

R408.3 Unvented crawl space. Ventilation openings in under-floor spaces specified in Sections R408.1 and R408.2 shall not be required where the following items are provided:

1. Exposed earth is covered with a continuous Class I vapor retarder. Joints of the vapor retarder shall overlap by 6 inches (152 mm) and shall be sealed or taped. The edges of the vapor retarder shall extend not less than 6 inches (152 mm) up the stem wall and shall be attached and sealed to the stem wall or insulation.
2. One of the following is provided for the under-floor space:
 - 2.1. Continuously operated mechanical exhaust ventilation at a rate equal to 1 cubic foot per minute (0.47 L/s) for each 50 square feet (4.7 m²) of crawl space floor area, including an air pathway to the common area (such as a duct or transfer grille), and perimeter walls insulated in accordance with Section N1102.2.11 of this code.
 - 2.2. *Conditioned air* supply sized to deliver at a rate equal to 1 cubic foot per minute (0.47 L/s) for each 50 square feet (4.7 m²) of under-floor area, including a return air pathway to the common area (such as a duct or transfer grille), and perimeter walls insulated in accordance with Section N1102.2.11 of this code.
 - 2.3. Plenum in existing structures complying with Section M1601.5, if under-floor space is used as a plenum.
 - 2.4. Dehumidification sized to provide 70 pints (33 liters) of moisture removal per day for every 1,000 ft² (93 m²) of crawl space floor area.

Reason: Unvented crawl spaces are required by Section R408.3 to provide to provide a method for moisture control. Typical conditioning measures involve supplying conditioned air from the occupied (conditioned) space of the building or exhausting air from the crawl space with make up air provided from the occupied (conditioned) space of the building. This code change allows another means of conditioning and controlling moisture, specifically dehumidification. Dehumidification is a proven technology. I am the original proponent of the existing code language for unvented crawl spaces. The existing language is based on a work done in the 1990's under the U.S. Department of Energy Building America Program. The work also examined dehumidification approaches. I had always intended to add dehumidification to the prescriptive part of the code 20 years ago but never got around to it. This change fixes that omission.

Cost Impact: Will not increase the cost of construction

This is a no cost change. This is an option. It allows another approach to conditioning crawl spaces that is equal to or less cost compared to providing supply and return air or an exhaust ventilation approach.

Report of Committee Action Hearings

Committee Action:

Approved as Submitted

Committee Reason: The committee agreed this a good addition as it adds an option for unvented crawl spaces that could be less costly than others.

Assembly Action:

None

Final Action Results

RB187-16

AS

[←BACK](#)

Code Change No: **RB189-16**

Original Proposal

Section: R502.1.3, R602.1.3, R802.1.2

Proponent: Edward Keith, representing APA- The Engineered Wood Association
(ed.keith@apawood.org)

Revise as follows:

R502.1.3 Structural glued laminated timbers. Glued laminated timbers shall be manufactured and identified as required in ANSI/AITC A190.1, ANSI 117 and ASTM ~~D 3737~~ D3737.

R602.1.3 Structural glued-laminated timbers. Glued-laminated timbers shall be manufactured and identified as required in ANSI/AITC A190.1, ANSI 117 and ASTM D 3737.

R802.1.2 Structural glued laminated timbers. Glued laminated timbers shall be manufactured and identified as required in ANSI/AITC A190.1, ANSI 117 and ASTM D 3737.

Reference standards type: This reference standard is new to the ICC Code Books
Add new standard(s) as follows:

ANSI 117-2015 Standard Specifications for Structural Glued Laminated Timber of Softwood Species

Reason: ANSI A190.1 and ANSI 117 are national consensus standards, previously known as ANSI/AITC A190.1 and AITC 117, respectively. In 2013, ANSI/AITC A190.1 and AITC 117 were renamed as ANSI A190.1 and ANSI 117 with the approval by ANSI. The new name for ANSI A190.1 found its way into Chapter 44 during the 2015 code cycle, but this change corrects references in code chapters.

ANSI 117 contains design and manufacturing requirements for structural glued laminated timber (glulam), which has been in use and recognized by the code (e.g., Section 2306.1 and Chapter 35 of the 2015 IBC) for more than 20 years. This change updates the standards reference in Sections R502.1.3, R602.1.3, and R802.1.2, and in Chapter 44 of the IRC. Note that APA is the standard developer accredited by ANSI for this national consensus standard and it is therefore placed under APA in Chapter 44. ANSI 117 is available for free download from the APA web site (http://www.apawood.org/download_pdf.aspx?pubid=f1f1ce6d-9390-46cd-b8f9-339ad36743df).

Cost Impact: Will not increase the cost of construction

This code change will not increase the cost of construction. It simply changes the entity responsible for the maintenance of these standards from the now defunct AITC to APA-The Engineered Wood Association.

Analysis: A review of the standard(s) proposed for inclusion in the code, ANSI 117-2015, with regard to the ICC criteria for referenced standards (Section 3.6 of CP#28) will be posted on the ICC website on or before April 1, 2016.

Report of Committee Action Hearings

Committee Action:

Approved as Submitted

Committee Reason: The committee approved this proposal based on the proponents published reason statement. This change updates the reference standard for glulam timbers.

Assembly Action:

None

Final Action Results

RB189-16

AS

[←BACK](#)

Code Change No: **RB192-16**

Original Proposal

Section: R502.6

Proponent: Richard Davidson, representing Self

Revise as follows:

R502.6 Bearing. The ends of each joist, beam or girder shall have not less than 1 1/2 inches (38 mm) of bearing on wood or metal and not less than 3 inches (76 mm) on masonry or concrete ~~except where.~~
~~Alternatively, the ends of joists shall be supported on a 1-inch by 4-inch (25 mm by 102 mm) ribbon strip and shall be nailed to the adjacent stud or fastened by the use means of approved joist hangers.~~
~~Alternatively, the ends of beams and girders shall be supported on approved connectors.~~ The bearing on masonry or concrete shall be direct, or a sill plate of 2-inch-minimum (51 mm) nominal thickness shall be provided under the joist, beam or girder. The sill plate shall provide a minimum nominal bearing area of 48 square inches (30 865 square mm).

Reason: Can you really support a beam or girder on a 1x4 ribbon strip or with a joist hanger? I don't think so. But that is what the code permits.

Cost Impact: Will not increase the cost of construction
 This is an editorial revision that should have no impact on costs.

Report of Committee Action Hearings

Committee Action:

Approved as Modified

Modify as follows:

R502.6 Bearing. The ends of each joist, beam or girder shall have not less than 1 1/2 inches (38 mm) of bearing on wood or metal and not less than 3 inches (76 mm) on masonry or concrete or be supported by approved joist hangers. Alternatively, the ends of joists shall be supported on a 1-inch by 4-inch (25 mm by 102 mm) ribbon strip and shall be nailed to the adjacent stud ~~or fastened by means of approved joist hangers.~~ ~~Alternatively, the ends of beams and girders shall be supported on approved connectors.~~ The bearing on masonry or concrete shall be direct, or a sill plate of 2-inch-minimum (51 mm) nominal thickness shall be provided under the joist, beam or girder. The sill plate shall provide a minimum nominal bearing area of 48 square inches (30 865 square mm).

Committee Reason: The committee agreed this change provides better organization of this section for current construction techniques. The modification improves the organization and the terminology.

Assembly Action

None

Final Action Results

RB192-16

AM

Code Change No: **RB195-16**

Original Proposal

Section: R505, R505.1.1, R505.1.3, R505.2.6.2, R505.3.2, R505.3.7

Proponent: Edward Keith, representing APA- The Engineered Wood Association (ed.keith@apawood.org)

Revise as follows:

SECTION R505 COLD-FORMED STEEL FLOOR FRAMING

R505.1.1 Applicability limits. The provisions of this section shall control the construction of cold-formed steel floor framing for buildings not greater than 60 feet (18 288 mm) in length perpendicular to the joist span, not greater than 40 feet (12 192 mm) in width parallel to the joist span and less than or equal to three stories above grade plane. Cold-formed steel floor framing constructed in accordance with the provisions of this section shall be limited to sites where the ultimate design wind speed is less than ~~139~~ 140 miles per hour (~~62-63~~ m/s), Exposure Category B or C, and the ground snow load is less than or equal to 70 pounds per square foot (3.35 kPa).

R505.1.3 Floor trusses. Cold-formed steel trusses shall be designed, braced and installed in accordance with ~~AISI S100, Section D4-S240~~. In the absence of specific bracing requirements, trusses shall be braced in accordance with accepted industry practices, such as the SBCA *Cold-Formed Steel Building Component Safety Information (CFSBCSI)*, *Guide to Good Practice for Handling, Installing & Bracing of Cold-Formed Steel Trusses*. Truss members shall not be notched, cut or altered in any manner without an *approved* design.

R505.2.6.2 Web hole reinforcing. Reinforcement of web holes in floor joists not conforming to the requirements of Section R505.2.6.1 shall be permitted if the hole is located fully within the center 40 percent of the span and the depth and length of the hole does not exceed 65 percent of the flat width of the web. The reinforcing shall be a steel plate or C-shape section with a hole that does not exceed the web hole size limitations of Section R505.2.6.1 for the member being reinforced. The steel reinforcing shall be ~~the same of minimum~~ thickness as the receiving member and shall extend not less than 1 inch (25 mm) beyond all edges of the hole. The steel reinforcing shall be fastened to the web of the receiving member with No. 8 screws spaced not more than 1 inch (25 mm) center-to-center along the edges of the patch with minimum edge distance of $\frac{1}{2}$ inch (12.7 mm).

TABLE R505.3.2
ALLOWABLE SPANS FOR COLD-FORMED STEEL JOISTS—SINGLE OR CONTINUOUS SPANS^{a, b, c, d, e}

JOIST DESIGNATION	30 PSF LIVE LOAD				40 PSF LIVE LOAD			
	Spacing (inches)				Spacing (inches)			
	12	16	19.2	24	12	16	19.2	24
550S162-33	41'-7"-11'-8"	40'-7"-10'-4"	9'-6"-9'-5"	8'-6"-8'-5"	10'-7"	9'-3"-9'-2"	8'-6"-8'-5"	7'-6"
550S162-43	12'-8"	11'-6"	10'-10" 10'-8"	10'-2" 10'-5"	11'-6"	10'-5" 10'-4"	9'-10"	9'-1"-9'- 3"
550S162-54	13'-7"	12'-4"	11'-7"	10'-9"	12'-4"	11'-2" 11'-3"	10'-6" 10'-7"	9'-9" 9'-10"
550S162-68	14'-7"	13'-3"	12'-6"	11'-7"	13'-3"	12'-0"	11'-4"	10'-6"

800S162-33	45'-8" <u>14'-6"</u>	43'-11" <u>12'-6"</u>	12'-9" <u>11'-5"</u>	11'-5" <u>10'-3"</u>	14'-3" <u>12'-10"</u>	12'-5" <u>11'-1"</u>	11'-3" <u>10'-2"</u>	9'-0" <u>9'-1"</u>
800S162-43	47'-1" <u>17'-0"</u>	45'-6" <u>15'-1"</u>	14'-7" <u>13'-9"</u>	13'-7" <u>12'-4"</u>	15'-6" <u>15'-5"</u>	14'-4" <u>13'-5"</u>	13'-3" <u>12'-3"</u>	12'-4" <u>10'-11"</u>
800S162-54	48'-4" <u>18'-3"</u>	46'-8" <u>16'-7"</u>	15'-8"	14'-7" <u>14'-6"</u>	16'-8" <u>16'-7"</u>	15'-2" <u>15'-1"</u>	14'-3" <u>14'-2"</u>	13'-3" <u>13'-2"</u>
800S162-68	19'-9"	17'-11"	16'-10" <u>16'-11"</u>	15'-8"	17'-11"	16'-3"	15'-4"	14'-2" <u>14'-3"</u>
1000S162-43	20'-6" <u>19'-4"</u>	18'-8" <u>16'-9"</u>	17'-6" <u>15'-3"</u>	15'-8" <u>13'-8"</u>	18'-8" <u>17'-2"</u>	16'-11" <u>14'-10"</u>	15'-6" <u>13'-7"</u>	13'-11" <u>12'-2"</u>
1000S162-54	22'-1" <u>21'-9"</u>	20'-0" <u>19'-9"</u>	18'-10" <u>18'-7"</u>	17'-6" <u>17'-3"</u>	20'-0" <u>19'-9"</u>	18'-2" <u>18'-0"</u>	17'-2" <u>16'-11"</u>	15'-11" <u>15'-8"</u>
1000S162-68	23'-9" <u>23'-7"</u>	21'-7" <u>21'-5"</u>	20'-3" <u>20'-2"</u>	18'-10" <u>18'-9"</u>	21'-7" <u>21'-5"</u>	19'-7" <u>19'-6"</u>	18'-5" <u>18'-4"</u>	17'-1" <u>17'-0"</u>
1200S162-43	23'-9"	20'-10"	19'-0"	16'-8"	21'-5"	18'-6"	16'-6"	13'-2"
1200S162-54	25'-9" <u>25'-1"</u>	23'-4" <u>22'-10"</u>	22'-0" <u>21'-6"</u>	20'-4" <u>19'-9"</u>	23'-4" <u>22'-10"</u>	21'-3" <u>20'-9"</u>	20'-0" <u>19'-6"</u>	17'-10" <u>17'-6"</u>
1200S162-68	27'-8" <u>27'-3"</u>	25'-1" <u>24'-9"</u>	23'-8" <u>23'-4"</u>	21'-11" <u>21'-8"</u>	25'-1" <u>24'-9"</u>	22'-10" <u>22'-6"</u>	21'-6" <u>21'-2"</u>	21'-1" <u>19'-8"</u>

For SI: 1 inch = 25.4 mm, 1 foot = 304.8 mm, 1 pound per square foot = 0.0479 kPa, 1 mil = 0.0254 mm.

- Deflection criteria: $L/480$ for live loads, $L/240$ for total loads.
- Floor dead load = 10 psf.
- Table provides the maximum clear span in feet and inches.
- Bearing stiffeners are to be installed at all support points and concentrated loads.
- Minimum Grade 33 ksi steel shall be used for 33 mil and 43 mil thickness. Minimum Grade 50 ksi steel shall be used for 54 and 68 mil thickness.
- Table is not applicable for 800S162-33 and 1000S162-43 continuous joist members

R505.3.7 Splicing. Joists and other structural members shall not be spliced without an approved design. Splicing of tracks shall conform to Figure R505.3.7.

Reference standards type: This reference standard is new to the ICC Code Books
Add new standard(s) as follows:

AISI S240-15, North American Standard for Cold-Formed Steel Structural Framing (2015)

Standards Available for free download at www.aisistandards.org

Reason: This proposal is one in a series intended to update the content of the Cold-Formed Steel (CFS) light-framed construction provisions of the IRC. The proposed revisions align the IRC with the provisions of *AISI S230-15, Standard for Cold-Formed Steel Framing - Prescriptive Method for One- and Two-Family Dwellings*. Further explanation for each section follows:
Applicability Limits - This proposal adjusts the upper limit of the ultimate design wind speed from less than 139 miles per hour (mph) to less than 140 mph. The previous upper limit was based on a conversion of the wind speed from a nominal speed to an ultimate speed. For which, the conversion of the 110 mph nominal wind speed resulted in a rounded value of 139 mph ultimate wind speed upper limit (ie. less than 139 mph). This is detailed in the last cycle code change proposal RB258-13. Since the wind speeds now listed in this section are actual ultimate wind speeds, as derived from the ultimate wind speed maps, this section is now applicable for ultimate wind speeds up to 140 mph.

Section R505.1.3 Floor Trusses - Previously this section referenced AISI S100, Section D for floor truss design. Section D of AISI S100 directed the user to *AISI S214 - North American Standard for Cold-Formed Steel Framing - Truss Design*. However, the new standard **AISI S240, North American Standard for Cold-Formed Steel Structural Framing**, addresses requirements for construction with cold-formed steel structural framing that are common to prescriptive and engineered light frame construction. This comprehensive standard was formed by merging the following AISI standards:

- AISI S200, *North American Standard for Cold-Formed Steel Framing-General Provisions*
- AISI S210, *North American Standard for Cold-Formed Steel Framing-Floor and Roof System Design*
- AISI S211, *North American Standard for Cold-Formed Steel Framing-Wall Stud Design*

- AISI S212, *North American Standard for Cold-Formed Steel Framing–Header Design*
- AISI S213, *North American Standard for Cold-Formed Steel Framing– Lateral Design*
- AISI S214, *North American Standard for Cold-Formed Steel Framing–Truss Design*

Consequently, AISI S240 supersedes all previous editions of the above mentioned individual AISI standards and is the correct reference for this application.

Section R505.2.6.2 Web Reinforcing - This is a correction to the language for web reinforcing. Holes in CFS members are permitted to be reinforced with steel of the same or greater thickness per AISI S230.

Table R505.3.2 Allowable Spans for CFS Joists - The listed allowable spans are updated to correspond to AISI S230-15.

Section R505.3.7 Splicing- Splicing of CFS members is permitted with approved design per AISI S230.

The AISI Standards are available for free download at www.aisistandards.org

Cost Impact: Will increase the cost of construction

The proposed changes to this section will not increase the cost of construction in general. While the overwhelming majority of the prescribed members have not changed or are reduced in size, there may be conditions for which the minimum member size will increase.

Analysis: A review of the standard(s) proposed for inclusion in the code, AISI 240-15, with regard to the ICC criteria for referenced standards (Section 3.6 of CP#28) will be posted on the ICC website on or before April 1, 2016.

Report of Committee Action Hearings

Committee Action:

Approved as Submitted

Committee Reason: This change aligns the cold-formed steel floor framing provisions with the new referenced cold-formed steel structural framing standard.

Also, the applicable design wind speed is changed to less than 140 mph ultimate.

Assembly Action:

None

Final Action Results

RB195-16

AS

[←BACK](#)

Code Change No: **RB198-16**

Original Proposal

Section: 507.3.5, R507, R507.1, R507.2, R507.2.1, R507.2.2, R507.2.3, R507.2.4, R507.3, R507.3 (New), R507.3.1, R507.3.2, R507.3.3, R507.3.4, R507.4, R507.5, R507.5.1, R507.6, R507.7, R507.7.1, R507.8, R507.8 (New), R507.8.1, R507.8.1 (New)

Proponent: Charles Bajnai, representing Deck Code Coalition and Chesterfield County, VA; and North American Deck and Railing Association (NADRA) (bajnaic@chesterfield.gov)

Revise as follows:

SECTION R507 EXTERIOR DECKS

~~R507.1 Decks.~~ Wood-framed decks shall be in accordance with this section ~~or Section R301 for.~~ For decks using materials and conditions not prescribed herein. Where supported by attachment in this section, refer to an exterior wall, decks shall be positively anchored to the primary structure and designed for both vertical and lateral loads Section R301.

~~Such attachment shall not be accomplished by the use of toenails or nails subject to withdrawal. Where positive connection to the primary building structure cannot be verified during inspection, decks shall be self-supporting. For decks with cantilevered framing members connections to exterior walls or other framing members shall be designed and constructed to resist uplift resulting from the full live load specified in Table R301.5 acting on the cantilevered portion of the deck.~~

~~R507.3~~ R507.2 Plastic composite deck boards, stair treads, guards, or handrails. Plastic composite exterior deck boards, stair treads, guards and handrails shall comply with the requirements of ASTM D 7032 and the requirements of Section ~~507.3~~ 507.2.

~~R507.3.1~~ R507.2.1 Labeling. Plastic composite deck boards and stair treads, or their packaging, shall bear a label that indicates compliance to ASTM D 7032 and includes the allowable load and maximum allowable span determined in accordance with ASTM D 7032. Plastic or composite handrails and guards, or their packaging, shall bear a label that indicates compliance to ASTM D 7032 and includes the maximum allowable span determined in accordance with ASTM D 7032.

~~R507.3.2~~ R507.2.2 Flame spread index. Plastic composite deck boards, stair treads, guards, and handrails shall exhibit a flame spread index not exceeding 200 when tested in accordance with ASTM E 84 or UL 723 with the test specimen remaining in place during the test.

Exception: Plastic composites determined to be noncombustible.

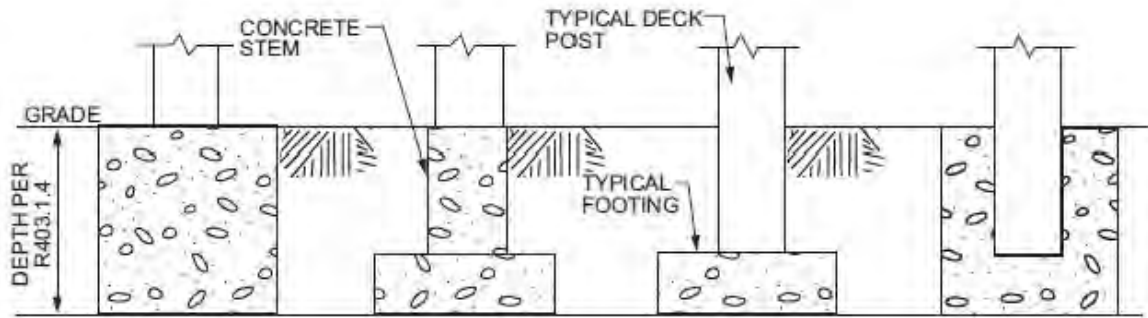
~~R507.3.3~~ R507.2.3 Decay resistance. Plastic composite deck boards, stair treads, guards and handrails containing wood, cellulosic or other biodegradable materials shall be decay resistant in accordance with ASTM D 7032.

~~R507.3.4~~ R507.2.4 Termite resistance. Where required by Section 318, plastic composite deck boards, stair treads, guards and handrails containing wood, cellulosic or other biodegradable materials shall be termite resistant in accordance with ASTM D 7032.

507.3.5 R507.2.5 Installation of plastic composites. Plastic composite deck boards, stair treads, guards and handrails shall be installed in accordance with this code and the manufacturer's instructions.

R507.3 Deck footings. Deck footings shall be sized to carry the imposed loads from the deck structure to the ground as shown in Figure R507.3. The footing depth shall be in accordance with Section R403.1.4.

**FIGURE R507.8.1 R507.3
TYPICAL DECK POSTS TO DECK FOOTINGS**



R507.8 R507.4 Deck posts. For single-level wood-framed decks with beams sized in accordance with Table R507.6 R507.5, deck post size shall be in accordance with Table R507.8 R507.4.

**TABLE R507.8 R507.4
DECK POST HEIGHT^a**

DECK POST SIZE	MAXIMUM HEIGHT ^a
4 x 4	8 ft
4 x 6	8 ft
6 x 6	14 ft

For SI: 1 foot = 304.8 mm.

a. Measured to the underside of the beam.

R507.8.1 R507.4.1 Deck post to deck footing. Posts shall bear on footings in accordance with Section R403 and Figure R507.8.1 R507.3. Posts shall be restrained to prevent lateral displacement at the bottom support. Such lateral restraint shall be provided by manufactured connectors installed in accordance with Section R507 and the manufacturers' instructions or a minimum post embedment of 12 inches (305 mm) in surrounding soils or concrete piers.

R507.6 R507.5 Deck Beams. Maximum allowable spans for wood deck beams, as shown in Figure R507.6 R507.5, shall be in accordance with Table R507.6 R507.5. Beam plies shall be fastened with two rows of 10d (3-inch x 0.128-inch) nails minimum at 16 inches (406 mm) on center along each edge. Beams shall be permitted to cantilever at each end up to one-fourth of the actual beam span. Splices of multispan beams shall be located at interior post locations.

**TABLE R507.6 R507.5
DECK BEAM SPAN LENGTHS^{a, b} (ft. - in.)**

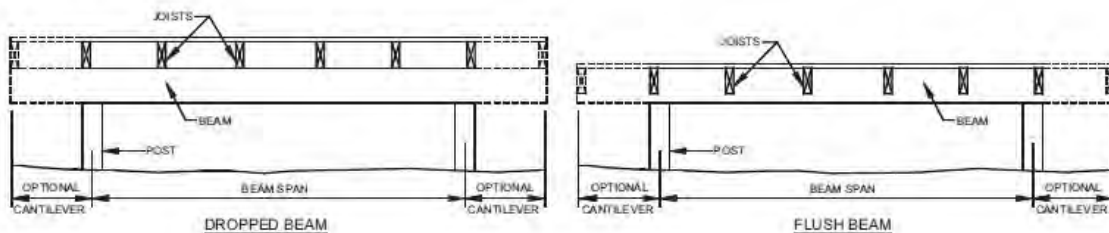
SPECIES ^c	SIZE ^d	DECK JOIST SPAN LESS THAN OR EQUAL TO: (feet)						
		6	8	10	12	14	16	18
Southern pine	2 - 2 x 6	6-11	5-11	5-4	4-10	4-6	4-3	4-0

	2 - 2 x 8	8-9	7-7	6-9	6-2	5-9	5-4	5-0
	2 - 2 x 10	10-4	9-0	8-0	7-4	6-9	6-4	6-0
	2 - 2 x 12	12-2	10-7	9-5	8-7	8-0	7-6	7-0
	3 - 2 x 6	8-2	7-5	6-8	6-1	5-8	5-3	5-0
	3 - 2 x 8	10-10	9-6	8-6	7-9	7-2	6-8	6-4
	3 - 2 x 10	13-0	11-3	10-0	9-2	8-6	7-11	7-6
	3 - 2 x 12	15-3	13-3	11-10	10-9	10-0	9-4	8-10
Douglas fir-larch ^e , hem-fir ^e , spruce-pine-fir ^e , redwood, western cedars, ponderosa pine ^f , red pine ^f	3 x 6 or 2 - 2 x 6	5-5	4-8	4-2	3-10	3-6	3-1	2-9
	3 x 8 or 2 - 2 x 8	6-10	5-11	5-4	4-10	4-6	4-1	3-8
	3 x 10 or 2 - 2 x 10	8-4	7-3	6-6	5-11	5-6	5-1	4-8
	3 x 12 or 2 - 2 x 12	9-8	8-5	7-6	6-10	6-4	5-11	5-7
	4 x 6	6-5	5-6	4-11	4-6	4-2	3-11	3-8
	4 x 8	8-5	7-3	6-6	5-11	5-6	5-2	4-10
	4 x 10	9-11	8-7	7-8	7-0	6-6	6-1	5-8
	4 x 12	11-5	9-11	8-10	8-1	7-6	7-0	6-7
	3 - 2 x 6	7-4	6-8	6-0	5-6	5-1	4-9	4-6
	3 - 2 x 8	9-8	8-6	7-7	6-11	6-5	6-0	5-8
	3 - 2 x 10	12-0	10-5	9-4	8-6	7-10	7-4	6-11
	3 - 2 x 12	13-11	12-1	10-9	9-10	9-1	8-6	8-1

For SI: 1 inch = 25.4 mm, 1 foot = 304.8 mm, 1 pound per square foot = 0.0479 kPa, 1 pound = 0.454 kg.

- Ground snow load, live load = 40 psf, dead load = 10 psf, $L/\Delta = 360$ at main span, $L/\Delta = 180$ at cantilever with a 220-pound point load applied at the end.
- Beams supporting deck joists from one side only.
- No. 2 grade, wet service factor.
- Beam depth shall be greater than or equal to depth of joists with a flush beam condition.
- Includes incising factor.
- Northern species. Incising factor not included.

**FIGURE R507.6-R507.5
TYPICAL DECK BEAM SPANS**



R507.7.1 R507.5.1 Deck post to deck beam. Deck beams shall be attached to deck posts in accordance with Figure ~~R507.7.1~~~~R507.5.1~~ or by other equivalent means capable to resist lateral displacement. Manufactured post-to-beam connectors shall be sized for the post and beam sizes. All bolts shall have washers under the head and nut.

Exception: Where deck beams bear directly on footings in accordance with Section ~~R507.8.1~~~~R507.4.1~~.

~~R507.5~~ R507.6 Deck joists. Maximum allowable spans for wood deck joists, as shown in Figure ~~R507.5~~~~R507.6~~, shall be in accordance with Table ~~R507.5~~~~R507.6~~. Maximum allowable spacing for joists shall be limited by the decking material in accordance with Table R507.7. Deck joists shall be permitted to cantilever not greater than one-fourth of the actual, adjacent joist span.

~~R507.5.1~~ R507.6.1 Lateral restraint at supports. Joist ends and bearing locations shall be provided with lateral restraint to prevent rotation. Where lateral restraint is provided by joist hangers or blocking between joists, their depth shall equal not less than 60 percent of the joist depth. Where lateral restraint is provided by rim joists, they shall be secured to the end of each joist with not less than (3) 10d (3-inch x 0.128-inch) nails or (3) No. 10 x 3-inch (76 mm) long wood screws.

~~R507.7~~ R507.6.2 Deck joist and deck beam bearing. The ends of each joist and beam shall have not less than $1\frac{1}{2}$ inches (38 mm) of bearing on wood or metal and not less than 3 inches (76 mm) on concrete or masonry for the entire width of the beam. Joist framing into the side of a ledger board or beam shall be supported by approved joist hangers. Joists bearing on a beam shall be connected to the beam to resist lateral displacement.

TABLE ~~R507.5~~R507.6
DECK JOIST SPANS FOR COMMON LUMBER SPECIES^f (ft. - in.)

SPECIES ^a	SIZE	SPACING OF DECK JOISTS WITH NO CANTILEVER ^b (inches)			SPACING OF DECK JOISTS WITH CANTILEVERS ^{c,f} (inches)		
		12	16	24	12	16	24
Southern pine	2 x 6	9-11	9-0	7-7	6-8	6-8	6-8
	2 x 8	13-1	11-10	9-8	10-1	10-1	9-8
	2 x 10	16-2	14-0	11-5	14-6	14-0	11-5
	2 x 12	18-0	16-6	13-6	18-0	16-6	13-6
Douglas fir-larch ^d , hem-fir ^d , spruce-pine-fir ^d	2 x 6	9-6	8-8	7-2	6-3	6-3	6-3
	2 x 8	12-6	11-1	9-1	9-5	9-5	9-1
	2 x 10	15-8	13-7	11-1	13-7	13-7	11-1
	2 x 12	18-0	15-9	12-10	18-0	15-9	12-10
Redwood, western cedars, ponderosa pine ^e , red pine ^e	2 x 6	8-10	8-0	7-0	5-7	5-7	5-7
	2 x 8	11-8	10-7	8-8	8-6	8-6	8-6
	2 x 10	14-11	13-0	10-7	12-3	12-3	10-7
	2 x 12	17-5	15-1	12-4	16-5	15-1	12-4

For SI: 1 inch = 25.4 mm, 1 foot = 304.8 mm, 1 pound per square foot = 0.0479 kPa, 1 pound = 0.454 kg.

- No. 2 grade with wet service factor.
- Ground snow load, live load = 40 psf, dead load = 10 psf, $L/\Delta = 360$.
- Ground snow load, live load = 40 psf, dead load = 10 psf, $L/\Delta = 360$ at main span, $L/\Delta = 180$ at cantilever with a 220-pound point load applied to end.
- Includes incising factor.
- Northern species with no incising factor
- Cantilevered spans not exceeding the nominal depth of the joist are permitted.

~~R507.4~~ R507.7 Decking. Maximum allowable spacing for joists supporting decking shall be in accordance with Table ~~R507.4~~~~R507.7~~. Wood decking shall be attached to each supporting member with not less than (2) 8d threaded nails or (2) No. 8 wood screws.

Page Intentionally Blank

**TABLE R507.4 R507.7
MAXIMUM JOIST SPACING**

MATERIAL TYPE AND NOMINAL SIZE	MAXIMUM ON-CENTER JOIST SPACING	
	Perpendicular to joist	Diagonal to joist ^a
1 ¹ / ₄ -inch-thick wood	16 inches	12 inches
2-inch-thick wood	24 inches	16 inches
Plastic composite	In accordance with Section R507.3 R507.2	In accordance with Section R507.3 R507.2

For SI: 1 inch = 25.4 mm, 1 foot = 304.8 mm, 1 degree = 0.01745 rad.

a. Maximum angle of 45 degrees from perpendicular for wood deck boards

R507.8 Vertical and lateral supports Where supported by attachment to an exterior wall, decks shall be positively anchored to the primary structure and designed for both vertical and lateral loads. Such attachment shall not be accomplished by the use of toenails or nails subject to withdrawal. For decks with cantilevered framing members, connection to exterior walls or other framing members shall be designed and constructed to resist uplift resulting from the full live load specified in Table R301.5 acting on the cantilevered portion of the deck. Where positive connection to the primary building structure cannot be verified during inspection, decks shall be self-supporting.

R507.8.1 Vertical supports. Vertical loads shall be transferred to band joists with ledgers in accordance with this section.

R507.2.1 R507.8.1.1 Ledger details. Deck ledgers installed in accordance with Section R507.2 shall be a minimum 2-inch by 8-inch (51 mm by 203 mm) nominal, pressure-preservative-treated southern pine, incised pressure-preservative-treated Hem-fir, or approved, naturally durable, No. 2 grade or better lumber. Deck ledgers installed in accordance with Section R507.2 shall not support concentrated loads from beams or girders. Deck ledgers shall not be supported on stone or masonry veneer.

R507.2.2 R507.8.1.2 Band joist details. Band joists attached by a ledger in accordance with Section R507.2 shall be a minimum 2-inch-nominal (51 mm), solid-sawn, spruce-pine-fir lumber or a minimum 1-inch by 9¹/₂-inch (25 mm × 241 mm) dimensional, Douglas fir, laminated veneer lumber. Band joists attached by a ledger in accordance with Section R507.2 shall be fully supported by a wall or sill plate below.

R507.2.3 R507.8.1.3 Ledger to band joist fastener details. Fasteners used in deck ledger connections in accordance with Table R507.2 R507.8.1.3(1) shall be hot-dipped galvanized or stainless steel and shall be installed in accordance with Table R507.2.4 R507.8.1.3(2) and Figures R507.2.4(1) R507.8.1.3(1) and R507.2.4(2) R507.8.1.3(2).

R507.2.4 R507.8.2 Deck lateral load connection. The lateral load connection required by Section R507.1 shall be permitted to be in accordance with Figure R507.2.3(1) or R507.2.3(2).

Where the lateral load connection is provided in accordance with Figure R507.2.3(1) R507.8.2(1), hold-down tension devices shall be installed in not less than two locations per deck, within 24 inches of each end of the deck. Each device shall have an allowable stress design capacity of not less than 1,500 pounds (6672 N).

Where the lateral load connections are provided in accordance with Figure R507.2.3(2) R507.8.2(2), the hold-down tension devices shall be installed in not less than four locations per deck, and each device shall have an allowable stress design capacity of not less than 750 pounds (3336 N).

TABLE R507.2-R507.8.1.3(1)
DECK LEDGER CONNECTION TO BAND JOIST^{a, b} (Deck live load = 40 psf, deck dead load = 10 psf, snow load ≤ 40 psf)

CONNECTION DETAILS	JOIST SPAN						
	6' and less	6'1" to 8'	8'1" to 10'	10'1" to 12'	12'1" to 14'	14'1" to 16'	16'1" to 18'
	On-center spacing of fasteners						
¹ / ₂ -inch diameter lag screw with ¹ / ₂ -inch maximum sheathing ^{c, d}	30	23	18	15	13	11	10
¹ / ₂ -inch diameter bolt with ¹ / ₂ -inch maximum sheathing ^d	36	36	34	29	24	21	19
¹ / ₂ -inch diameter bolt with 1-inch maximum sheathing ^e	36	36	29	24	21	18	16

For SI: 1 inch = 25.4 mm, 1 foot = 304.8 mm, 1 pound per square foot = 0.0479 kPa.

- a. Ledgers shall be flashed in accordance with Section R703.4 to prevent water from contacting the house band joist.
- b. Snow load shall not be assumed to act concurrently with live load.
- c. The tip of the lag screw shall fully extend beyond the inside face of the band joist.
- d. Sheathing shall be wood structural panel or solid sawn lumber.
- e. Sheathing shall be permitted to be wood structural panel, gypsum board, fiberboard, lumber or foam sheathing. Up to ¹/₂ -inch thickness of stacked washers shall be permitted to substitute for up to ¹/₂ inch of allowable sheathing thickness where combined with wood structural panel or lumber sheathing.

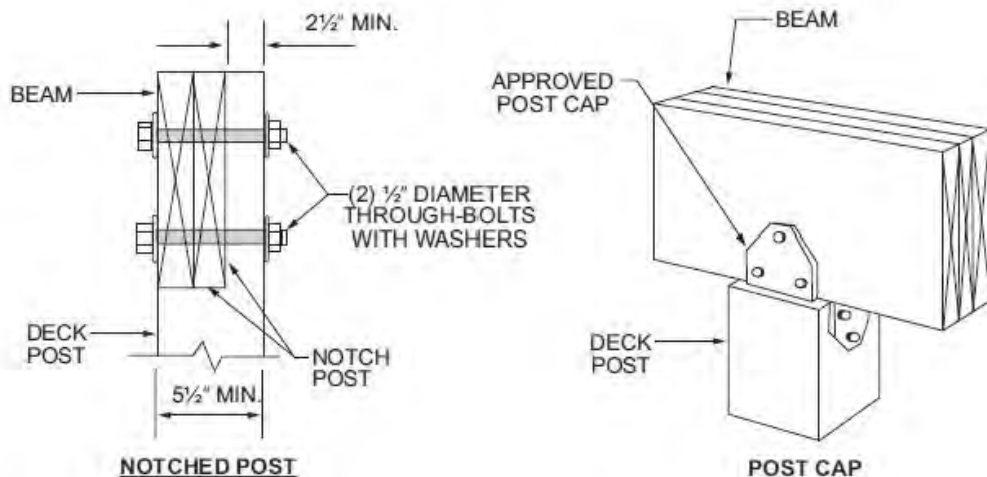
TABLE R507.2.1-R507.8.1.3(2)
PLACEMENT OF LAG SCREWS AND BOLTS IN DECK LEDGERS AND BAND JOISTS-
MINIMUM END AND EDGE DISTANCES AND SPACING BETWEEN ROWS

	TOP EDGE	BOTTOM EDGE	ENDS	ROW SPACING
Ledger ^a	2 inches ^d	³ / ₄ inch	2 inches ^b	1 ⁵ / ₈ inches ^b
Band Joist ^c	³ / ₄ inch	2 inches	2 inches ^b	1 ⁵ / ₈ inches ^b

For SI: 1 inch = 25.4 mm.

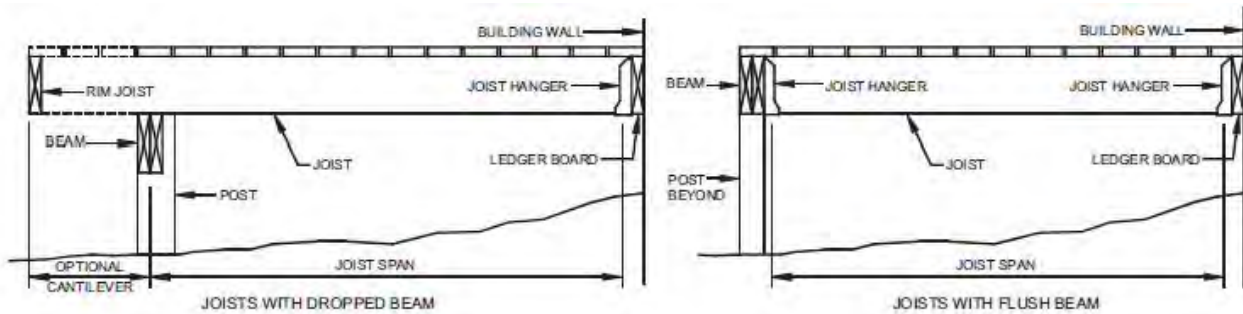
- a. Lag screws or bolts shall be staggered from the top to the bottom along the horizontal run of the deck ledger in accordance with Figure R507.2.1(1)R507.8.1.3(1).
- b. Maximum 5 inches.
- c. For engineered rim joists, the manufacturer's recommendations shall govern.
- d. The minimum distance from bottom row of lag screws or bolts to the top edge of the ledger shall be in accordance with Figure R507.2.1(1)R507.8.1.3(1).

FIGURE R507.7.1-R507.5.1
DECK BEAM TO DECK POST



For SI: 1 inch = 25.4 mm.

**FIGURE R507.5-R507.6
TYPICAL DECK JOIST SPANS**



**FIGURE R507.2.4(2)-R507.8.1.3(2)
PLACEMENT OF LAG SCREWS AND BOLTS IN BAND JOISTS**
(Portions of figure not shown remain unchanged)

**FIGURE R507.2.4(4)-R507.8.1.3(1)
PLACEMENT OF LAG SCREWS AND BOLTS IN LEDGERS**
(Portions of figure not shown remain unchanged)

**FIGURE R507.2.3(2)-R507.8.2(2)
DECK ATTACHMENT FOR LATERAL LOADS**
(Portions of figure not shown remain unchanged)

**FIGURE R507.2.3(4)-R507.8.2(1)
DECK ATTACHMENT FOR LATERAL LOADS**
(Portions of figure not shown remain unchanged)

Reason:

WHAT: The entire section is reorganized without any technical changes, based on similar organization in the IRC, namely, starting at the footings and working upward.

WHY: The Deck Code Coalition (DCC) recognized that R507 was created in the 2012 IRC. Related pieces were plucked from the 2012 IRC and tacked on the end of 2015 R507 without any consideration of organization. Hence *lateral connections* precede *decking* which precedes *deck joists*, etc. This proposal sets the framework for the other code changes by the DCC and will make it easier for everyone to follow the deck construction sequentially. This is how the pieces are

relocated

New Section				Old Section	
R507.1		Decks	minor text amendment	R507.1	Decks
R507.2		Plastic composite deck boards, stair treads, guards, or handrails.	Renumbering	R507.3	Plastic composite deck boards, stair treads, guards, or handrails.
	R507.2.1	Labeling	Renumbering	R507.3.1	Labeling
	R507.2.2	Flame spread index.	Renumbering	R507.3.2	Flame spread index.
	R507.2.3	Decay resistance	Renumbering	R507.3.3	Decay resistance
	R507.2.4	Termite resistance	Renumbering	R507.3.4	Termite resistance
	R507.2.5	Installation of plastic composites	Renumbering	507.3.5	Installation of plastic composites
R507.3		Deck footings	new charging language		
R507.4		Deck posts	Renumbering	R507.8	Deck posts
	R507.4.1	Deck post to deck footing	Renumbering	R507.8.1	Deck post to deck footing
R507.5		Deck beams	Renumbering	R507.6	Deck Beams.
	R507.5.1	Deck post to deck beam	Renumbering	R507.7.1	Deck post to deck beam
			Renumbering and nontechnical cross reference added	R507.5	Deck joists
	R506.1	Lateral resistance at supports	Renumbering	R507.5.1	Lateral resistance at supports
	R506.2		Renumbering	R507.7	Deck joist and deck beam bearing
R507.7		Decking	Renumbering	R507.4	Decking
R507.8		Vertical and lateral supports	Renumbering and relocated parts of this section	R507.1	Decks
	R507.8.1	Vertical supports	new charging language		
	R507.8.1.1	Ledger details	Renumbering and merge sections	R507.2.1	Ledger details
	R507.8.1.2	Band joist details	Renumbering	R507.8.2	Deck ledger connection to band joist
	R507.8.1.3	Ledger to band joist fastener details	Renumbering	R507.2.2	Band joist details
				R507.2.3	Ledger to band joist fastener details
	R507.8.2	Lateral connections	Renumbering	R507.2.4	Deck lateral load connection

Cost Impact: Will not increase the cost of construction
There should be no cost impact, as this is purely a non-technical code change.

Report of Committee Action Hearings

Committee Action:

Approved as Submitted

Committee Reason: The committee agrees this is a good change that provides a needed reorganization and brings clarity to this section. Also, the change was developed by a consensus group made up of stakeholders of the deck industry.

Assembly Action:

None

Final Action Results

RB198-16

AS

[←BACK](#)

[←BACK](#)

Code Change No: **RB200-16**

Original Proposal

Section(s): R507, R507.5.1(2) (New), R507.6, R507.7, R507.7.1

Proponent: Charles Bajnai, representing Deck Code Coalition and Chesterfield County, VA; and North American Deck and Railing Association (NADRA) (bajnaic@chesterfield.gov)

Revise as follows:

SECTION R507 EXTERIOR DECKS

~~**R507.6**~~ **R507.5 Deck Beams.** Maximum allowable spans for wood deck beams, as shown in Figure ~~R507.6~~ R507.5, shall be in accordance with Table ~~R507.6~~ R507.5. Beam plies shall be fastened with two rows of 10d (3-inch x 0.128-inch) nails minimum at 16 inches (406 mm) on center along each edge. Beams shall be permitted to cantilever at each end up to one-fourth of the ~~actual~~ adjacent beam span. ~~Splices Deck beams of multispans beams other materials shall be located at interior post locations permitted when designed in accordance with accepted engineering practice.~~

~~**R507.7**~~ **R507.5.1 Deck joist and deck beam bearing.** The ends of each ~~joist and beam~~ shall have not less than 1 1/2 inches (38 mm) of bearing on wood or metal and not less than 3 inches (76 mm) on concrete or masonry for the entire width of the beam. ~~Joist framing into the side of a ledger board or beam shall be supported by approved joist hangers. Joists~~ Where multispans beams bear on intermediate posts, each ply must have full bearing on a beam shall be connected to the beam to resist lateral displacement post in accordance with Figures R507.5.1(1) and R507.5.1(2).

~~**R507.7.1**~~ **R507.5.2 Deck post to deck beam connection.** Deck beams shall be attached to wood deck posts in a manner capable of resisting vertical and horizontal applied loads. Connections shall be in accordance with Figure R507.7.1 or by other equivalent means capable to resist lateral displacement Figures R507.5.1(1) and R507.5.1(2). ~~Manufactured post-to-beam connectors shall be sized for the post and beam sizes. All bolts shall have washers under the head and nut.~~

~~**Exception:** Where deck beams bear directly on footings in accordance with Section R507.8.1.~~

Deck beams shall be attached to concrete or masonry piers in a manner capable of resisting vertical and horizontal applied loads. Other attachment methods shall be permitted.

TABLE ~~R507.6~~ R507.5
DECK BEAM SPAN LENGTHS^{a, b, d} (ft. - in.)

SPECIES ^c	SIZE ^d	DECK JOIST SPAN LESS THAN OR EQUAL TO: (feet)						
		6	8	10	12	14	16	18
Southern pine	1- 2 x 6	4-11	4-0	3-7	3-3	3-0	2-10	2-8
	1- 2 x 8	5-11	5-1	4-7	4-2	2-10	3-7	3-5
	1- 2 x 10	7-0	6-0	5-5	4-11	4-7	4-3	4-0
	1- 2 x 12	8-3	7-1	6-4	5-10	5-5	5-0	4-9
	2- 2 x 6	6-11	5-11	5-4	4-10	4-6	4-3	4-0
	2- 2 x 8	8-9	7-7	6-9	6-2	5-9	5-4	5-0

SPECIES ^c	SIZE ^d	DECK JOIST SPAN LESS THAN OR EQUAL TO: (feet)						
		6	8	10	12	14	16	18
	2 – 2 × 10	10-4	9-0	8-0	7-4	6-9	6-4	6-0
	2 – 2 × 12	12-2	10-7	9-5	8-7	8-0	7-6	7-0
	3 – 2 × 6	8-2	7-5	6-8	6-1	5-8	5-3	5-0
	3 – 2 × 8	10-10	9-6	8-6	7-9	7-2	6-8	6-4
	3 – 2 × 10	13-0	11-3	10-0	9-2	8-6	7-11	7-6
	3 – 2 × 12	15-3	13-3	11-10	10-9	10-0	9-4	8-10
Douglas fir-larch ^e , hem-fir ^e , spruce-pine-fir ^e , redwood, western cedars, ponderosa pine ^f , red pine ^f	3 × 6 or 2 – 2 × 6	5-5	4-8	4-2	3-10	3-6	3-1	2-9
	3 × 8 or 2 – 2 × 8	6-10	5-11	5-4	4-10	4-6	4-1	3-8
	3 × 10 or 2 – 2 × 10	8-4	7-3	6-6	5-11	5-6	5-1	4-8
	3 × 12 or 2 – 2 × 12	9-8	8-5	7-6	6-10	6-4	5-11	5-7
	4 × 6	6-5	5-6	4-11	4-6	4-2	3-11	3-8
	4 × 8	8-5	7-3	6-6	5-11	5-6	5-2	4-10
	4 × 10	9-11	8-7	7-8	7-0	6-6	6-1	5-8
	4 × 12	11-5	9-11	8-10	8-1	7-6	7-0	6-7
	3 – 2 × 6	7-4	6-8	6-0	5-6	5-1	4-9	4-6
	3 – 2 × 8	9-8	8-6	7-7	6-11	6-5	6-0	5-8
	3 – 2 × 10	12-0	10-5	9-4	8-6	7-10	7-4	6-11
	3 – 2 × 12	13-11	12-1	10-9	9-10	9-1	8-6	8-1

For SI: 1 inch = 25.4 mm, 1 foot = 304.8 mm, 1 pound per square foot = 0.0479 kPa, 1 pound = 0.454 kg.

a. Ground snow load, live load = 40 psf, dead load = 10 psf, $L/\Delta = 360$ at main span, $L/\Delta = 180$ at cantilever with a 220-pound point load applied at the end.

b. Beams supporting deck joists from one side only.

c. No. 2 grade, wet service factor.

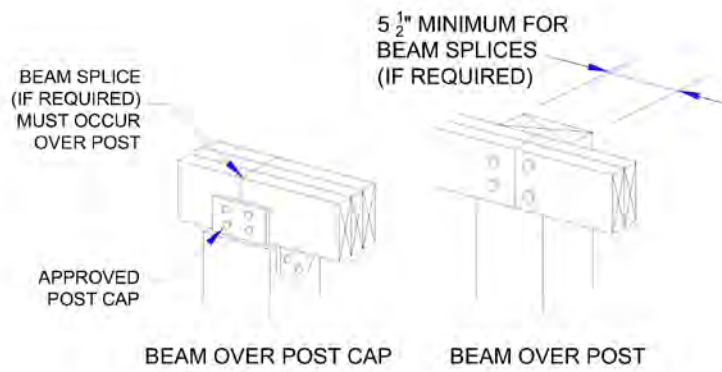
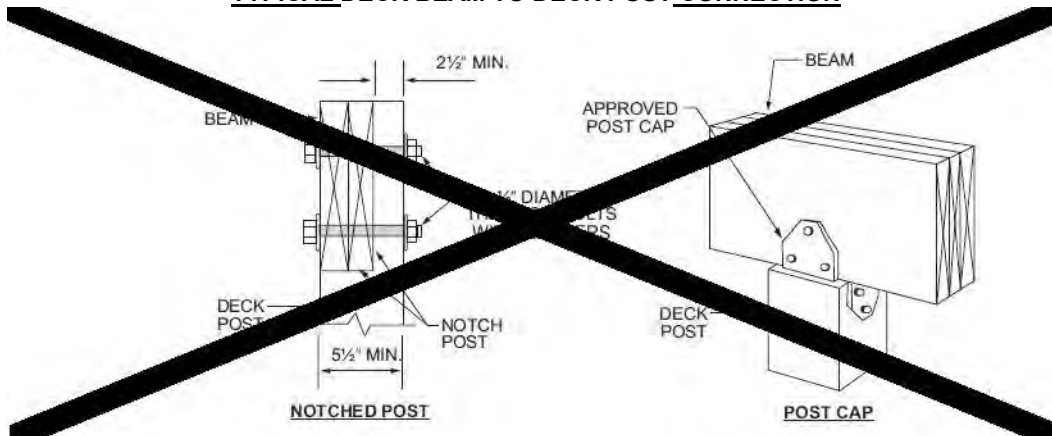
d. Beam depth shall be greater than or equal to depth of joists with a flush beam condition.

e. Includes incising factor.

f. Northern species. Incising factor not included.

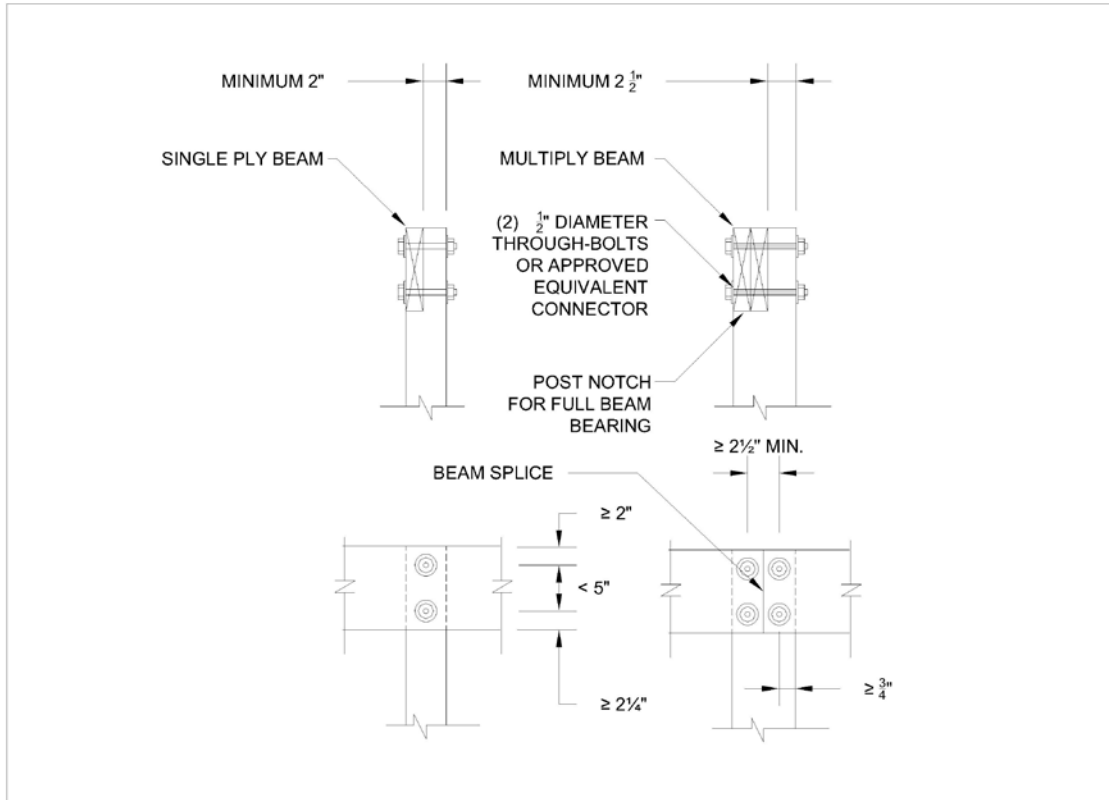
g. Beam cantilevers are limited to adjacent beam span divided by 4.

FIGURE R507.7.1 R507.5.1(1)
TYPICAL DECK BEAM TO DECK POST CONNECTION

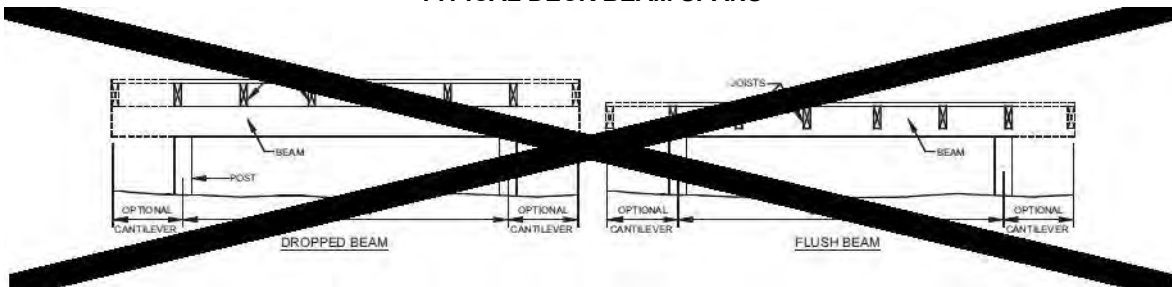


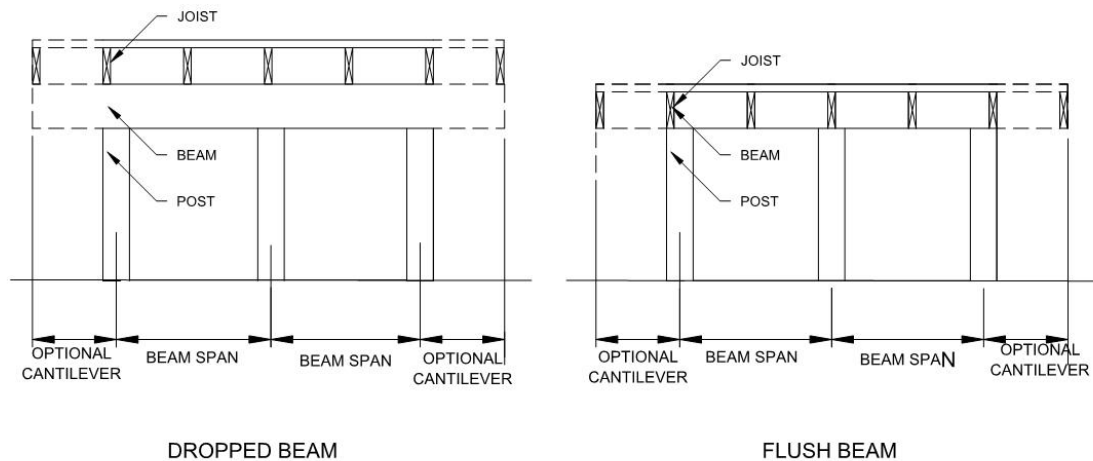
For SI: 1 inch = 25.4 mm.

FIGURE R507.5.1(2)
NOTCHED POST-TO-BEAM CONNECTION



~~**FIGURE R507.6-R507.5**~~
~~**TYPICAL DECK BEAM SPANS**~~



**Reason:**

WHAT: This code proposal amends these things:

1. It moves together sections R507.6, R507.7 and R507.1 into a new section *BEAMS*,
2. It provides better figures to show how beam splices are to occur over posts,
3. It revises the beam span figure by showing a beam spanning multiple deck posts.
4. And the beam table was expanded to cover single ply beams used for small decks, porches or landings.

WHY: The Deck Code Coalition (DCC) thought the current wording needed improvement. Also the figures needed refinement to reflect the wording changes and cover more options. The committee wanted to add flexibility to the beam table and allow for single ply beams.



The Deck Code Coalition (DCC) is a diverse group of stakeholders, including building officials, industry associations, product manufacturers, design professionals, and academia who have worked since the 2012 IRC code development cycle in an effort to consolidate and improve deck construction methods from across the country.

Our goals are threefold:

1. Consolidate existing code scattered throughout the IRC under the newly expanded Section R507. Being able to easily locate all deck related code provisions in one section equally serves the builder, code official and design professional to a safer, code-conforming deck.
2. Create realistic, fact-based, prescriptive solutions to fill critical gaps in the current deck code. Many parts of existing deck code rely on subjective interpretations by the reader leading to an inconsistent approach to meeting minimum code.
3. Maintain and promote a safer deck structure without unduly burdening the builder. In all cases the DCC want to offer safe minimum requirements without stifling the creativity of the design professional or builder.

Cost Impact: Will not increase the cost of construction

There is no cost impact. It may even save a few dollars by allowing single ply beams.

Report of Committee Action Hearings
--

Committee Action:

Disapproved

Committee Reason: The language in Section R507.2 is too confusing. The modification that was disapproved would help. The proponent should rework and bring this back in a public comment

Assembly Action:

None

Public Comments

Public Comment 1:

Charles Bajnai, representing Deck Code Coalition and Chesterfield County, VA; and North American Deck and Railing Association (NADRA) (bajnaic@chesterfield.gov) requests Approve as Modified by this Public Comment.

Modify as follows:

R507.5 Deck Beams. Maximum allowable spans for wood deck beams, as shown in Figure R507.5, shall be in accordance with Table R507.5. Beam plies shall be fastened with two rows of 10d (3-inch x 0.128-inch) nails minimum at 16 inches (406 mm) on center along each edge. Beams shall be permitted to cantilever at each end up to one-fourth of the adjacent allowable beam span. Deck beams of other materials shall be permitted when designed in accordance with accepted engineering practice.

R507.5.1 Deck beam bearing. The ends of each beam shall have not less than $1\frac{1}{2}$ inches (38 mm) of bearing on wood or metal and not less than 3 inches (76 mm) on concrete or masonry for the entire width of the beam. Where multispans beams bear on intermediate posts, each ply must have full bearing on the post in accordance with Figures R507.5.1(1) and R507.5.1(2).

R507.5.2 Deck ~~post-beam connections to deck beam connection supports.~~ Deck beams shall be attached to wood deck posts ~~supports~~ in a manner capable of ~~transferring resisting vertical loads and resisting horizontal applied loads displacement.~~ ~~Connections Deck beam connections to wood posts~~ shall be in accordance with Figures R507.5.1(1) and R507.5.1(2). Manufactured post-to-beam connectors shall be sized for the post and beam sizes. All bolts shall have washers under the head and nut. ~~Deck beams shall be attached to concrete or masonry piers in a manner capable of resisting vertical and horizontal applied loads. Other attachment methods shall be permitted.~~

Commenter's Reason:

R507.5:

This public comment corrects an improper word choice in the original proposal: the allowed cantilever should be one fourth of the allowed span in Table R507.5, not one fourth of the adjacent span. This is based upon how the calculations for the table were made, which always assumed a one fourth cantilever.

R507.5.2:

1. The function of the beam connection is to resist horizontal displacement and transfer vertical load.
2. The last sentence was intended to allow for alternative deck beam attachments; however, where it is currently located, the word "other" suggests attachments that do not resist vertical or horizontal applied loads. This was obviously not the intent and is easiest to fix by striking the sentence.

Final Action Results

RB200-16

AMPC1

[←BACK](#)

Code Change No: **RB203-16**

Original Proposal

Section: R507, R507.2, R507.2.1, R507.2.2, R507.2.3, R507.2.4, R507.9.1 (New), R507.9.1.4 (New)

Proponent: Charles Bajnai, representing Deck Code Coalition and Chesterfield County, VA; and North American Deck and Railing Association (NADRA) (bajnaic@chesterfield.gov)

Revise as follows:

SECTION R507 EXTERIOR DECKS

~~R507.2~~ ~~R507.9~~ **Deck ledger connection to Vertical and lateral supports at band joist.** Deck ledger connections to band joists

Vertical and lateral supports for decks shall be in accordance comply with this section, Tables R507.2 and R507.2.1, and Figures R507.2.1(1) and R507.2.1(2). For other grades, species, connection details and loading conditions, deck ledger connections shall be designed in accordance with Section R301.

R507.9.1 Vertical supports. Vertical loads shall be transferred to the band joists with ledgers in accordance with this section.

~~R507.2.1~~ ~~R507.9.1.1~~ **Ledger details.** Deck ledgers installed in accordance with Section R507.2 shall be a minimum 2-inch by 8-inch (51 mm by 203 mm) nominal, pressure-preservative-treated southern pine, incised pressure-preservative-treated Hem-fir, or approved, naturally durable, No. 2 grade or better lumber. Deck ledgers installed in accordance with Section R507.2 shall not support concentrated loads from beams or girders. Deck ledgers shall not be supported on stone or masonry veneer.

~~R507.2.2~~ ~~R507.9.1.2~~ **Band joist details.** Band joists attached by supporting a ledger in accordance with Section R507.2 shall be a minimum 2-inch-nominal (51 mm), solid-sawn, spruce-pine-fir or better lumber or a minimum 1-inch by 9' 1/2-inch (25 mm x 241 mm) dimensional, Douglas fir or better lumber, laminated veneer lumber. Band joists attached by a ledger in accordance with Section R507.2 shall be bear fully supported by a wall or sill plate below on the primary structure capable of supporting all required loads.

~~R507.2.3~~ ~~R507.9.1.3~~ **Ledger to band joist fastener details.** Fasteners used in deck ledger connections in accordance with Table ~~R507.2~~ ~~R507.9.1.3(1)~~ shall be hot-dipped galvanized or stainless steel and shall be installed in accordance with Table ~~R507.2.1~~ ~~R507.9.1.3(2)~~ and Figures ~~R507.2.1(1)~~ ~~R507.9.1.3(1)~~ and ~~R507.2.1(2)~~ ~~R507.9.1.3(2)~~.

R507.9.1.4 Alternate ledger details. Alternate framing configurations supporting a ledger constructed to meet the load requirements of Section R301.5 shall be permitted.

TABLE ~~R507.2~~ ~~R507.9.1.3(1)~~

DECK LEDGER CONNECTION TO BAND JOIST^{a, b} (Deck live load = 40 psf, deck dead load = 10 psf, snow load ≤ 40 psf)

(Portions of table not shown remain unchanged)

For SI: 1 inch = 25.4 mm, 1 foot = 304.8 mm, 1 pound per square foot = 0.0479 kPa.

- a. Ledgers shall be flashed in accordance with Section R703.4 to prevent water from contacting the house band joist.
- b. Snow load shall not be assumed to act concurrently with live load.
- c. The tip of the lag screw shall fully extend beyond the inside face of the band joist.
- d. Sheathing shall be wood structural panel or solid sawn lumber.
- e. Sheathing shall be permitted to be wood structural panel, gypsum board, fiberboard, lumber or foam sheathing. Up to 1/2 -inch

thickness of stacked washers shall be permitted to substitute for up to $1/2$ inch of allowable sheathing thickness where combined with wood structural panel or lumber sheathing.

**TABLE ~~R507.2.4~~-~~R507.9.1.3(2)~~
PLACEMENT OF LAG SCREWS AND BOLTS IN DECK LEDGERS AND BAND JOISTS-**

(Portions of table not shown remain unchanged)

For SI: 1 inch = 25.4 mm.

- a. Lag screws or bolts shall be staggered from the top to the bottom along the horizontal run of the deck ledger in accordance with Figure R507.2.1(1).
- b. Maximum 5 inches.
- c. For engineered rim joists, the manufacturer's recommendations shall govern.
- d. The minimum distance from bottom row of lag screws or bolts to the top edge of the ledger shall be in accordance with Figure R507.2.1(1).

~~R507.2.4~~-~~R507.9.2~~ Deck lateral load Lateral connection. The lateral load connection required by Section ~~R507.4~~. Lateral loads shall be permitted transferred to be in accordance with Figure ~~R507.2.3(1)~~ the ground or ~~R507.2.3(2)~~ to a structure capable of transmitting them to the ground.

Where the lateral load connection is provided in accordance with Figure ~~R507.2.3(1)~~-~~R507.9.2(1)~~, hold-down tension devices shall be installed in not less than two locations per deck, within 24 inches of each end of the deck. Each device shall have an allowable stress design capacity of not less than 1,500 pounds (6672 N).

Where the lateral load connections are provided in accordance with Figure ~~R507.2.3(2)~~-~~R507.9.2(2)~~, the hold-down tension devices shall be installed in not less than four locations per deck, and each device shall have an allowable stress design capacity of not less than 750 pounds (3336 N).

**FIGURE ~~R507.2.1(1)~~-~~R507.9.1.3(1)~~
PLACEMENT OF LAG SCREWS AND BOLTS IN LEDGERS**

(Portions of figure not shown remain unchanged)

For SI: 1 inch = 25.4 mm.

For SI: 1 inch = 25.4 mm.

**FIGURE ~~R507.2.1(2)~~-~~R507.9.1.3(2)~~
PLACEMENT OF LAG SCREWS AND BOLTS IN BAND JOISTS**

(Portions of figure not shown remain unchanged)

**FIGURE ~~R507.2.3(1)~~-~~R507.9.2(1)~~
DECK ATTACHMENT FOR LATERAL LOADS**

(Portions of figure not shown remain unchanged)

For SI: 1 inch = 25.4 mm.

For SI: 1 inch = 25.4 mm, 1 foot = 304.8 mm.

**FIGURE ~~R507.2.3(2)~~-~~R507.9.2(2)~~
DECK ATTACHMENT FOR LATERAL LOADS**

(Portions of figure not shown remain unchanged)

Reason:

WHAT: This code change moves the deck ledger attachment and lateral resistance details from Section R507. 2 to the end of the section.

WHY: The Deck Code Coalition (DCC) thought that the organization of the section would make more sense if it followed the same logical organization as the IRC in whole, namely from the ground up. We moved the ledger attachment details to the end of the section similar to the way wall bracing in R602.10 has supports at the end of the section.

The Deck Code Coalition (DCC) is a diverse group of stakeholders, including building officials, industry associations, product manufacturers, design professionals, and academia who have worked since the 2012 IRC code development cycle in an effort to consolidate and improve deck construction methods from across the country.

Our goals are threefold:

1. Consolidate existing code scattered throughout the IRC under the newly expanded Section R507. Being able to easily locate all deck related code provisions in one section equally serves the builder, code official and design professional to a safer, code-conforming deck.

2. Create realistic, fact-based, prescriptive solutions to fill critical gaps in the current deck code. Many parts of existing deck code rely on subjective interpretations by the reader leading to an inconsistent approach to meeting minimum code.

Maintain and promote a safer deck structure without unduly burdening the builder. In all cases the DCC want to offer safe minimum requirements

Cost Impact: Will not increase the cost of construction

There is no cost impact. This is a non-technical code change - it only moved the requirements from R507.2 to the end of the section.

Report of Committee Action Hearings

Committee Action:

Approved as Submitted

Committee Reason: The committee approved this proposal based on the proponents published reason statement.

Assembly Action:

None

Final Action Results

RB203-16

AS

[←BACK](#)

Code Change No: **RB205-16**

Original Proposal

Section: R507, R507.3 (New), R507.3.1 (New), R507.3.2 (New)

Proponent: Charles Bajnai, representing Deck Code Coalition and Chesterfield County, VA; and North American Deck and Railing Association (NADRA) (bajnaic@chesterfield.gov)

Add new text:

R507.3 Footings. Decks shall be supported on concrete footings or other approved structural systems designed to accommodate all loads according to Section R301.

R507.3.1 Minimum size. The minimum size of concrete footings shall be in based on the tributary area and allowable soil bearing pressure in accordance with Table R401.4.1.

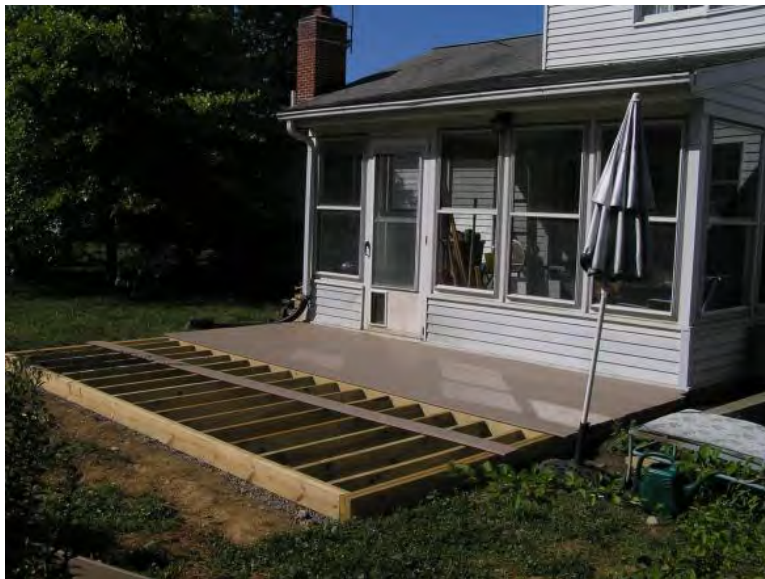
R507.3.2 Minimum depth. Deck footings shall extend below the frost line specified in Table R301.2(1) in accordance with Section R403.1.4.1.

Exception: Freestanding decks consisting of joists directly supported on grade over their entire length

Reason:

WHAT: This code change provides an exception for "freestanding wood patios" from having to comply with the requirement in R403 footings below frost line. It will allow a freestanding deck to be totally supported on the ground without any footings.

WHY: The Deck Code Coalition (DCC) did not foresee any safety concerns and thought it was reasonable to add language to affirm that freestanding wood patios do not need to have footings below the frost line. The code change complies with the requirement of R403.1.4.1, Exception #3: "Decks not supported by a dwelling need not be provided with footings that extend below the frost line."



The Deck Code Coalition (DCC) is a diverse group of stakeholders, including building officials, industry associations, product manufacturers, design professionals, and academia who have worked since the 2012 IRC code development cycle in an effort to consolidate and improve deck construction methods from across the country.

Our goals are threefold:

1. Consolidate existing code scattered throughout the IRC under the newly expanded Section R507. Being able to easily locate all deck related code provisions in one section equally serves the builder, code official and design professional to a safer, code-conforming deck.
2. Create realistic, fact-based, prescriptive solutions to fill critical gaps in the current deck code. Many parts of existing deck code rely on subjective interpretations by the reader leading to an inconsistent approach to meeting minimum code.
3. Maintain and promote a safer deck structure without unduly burdening the builder. In all cases the DCC want to offer safe minimum requirements without stifling the creativity of the design professional or builder.

Cost Impact: Will not increase the cost of construction

There is no cost impact. The code already provides an exception for footings below the frost line in Section R403.1.4.1 for freestanding decks.

Report of Committee Action Hearings
--

Committee Action:

Approved as Modified

Modify as follows:

R507.3 Footings. Decks shall be supported on concrete footings or other approved structural systems designed to accommodate all loads according to Section R301.

Exception: Freestanding decks consisting of joists directly supported on grade over their entire length.

R507.3.2 Minimum depth. Deck footings shall extend below the frost line specified in Table R301.2(1) in accordance with Section R403.1.4.1.

Exception: ~~Freestanding decks consisting of joists directly supported on grade over their entire length~~

Committee Reason: The committee approved this proposal based on the proponents published reason statement. This change provides allowance for footing size for decks. The modification moves the exception to the proper section.

Assembly Action

None

Final Action Results

RB205-16

AM

[←BACK](#)

Code Change No: RB206-16**Original Proposal**

Section: R507, R507.3 (New), R507.3.1 (New), R507.3.2 (New)

Proponent: Charles Bajnai, representing Deck Code Coalition and Chesterfield County, VA; and North American Deck and Railing Association (NADRA) (bajnaic@chesterfield.gov)

Add new text as follows:

R507.3 Footings Decks shall be supported on concrete footings or other approved structural systems designed to accommodate all loads according to Section R301.

R507.3.1 Minimum size. **R507.3.1 Minimum size.** The minimum size of concrete footings shall be based on the tributary area and allowable soil bearing pressure in accordance with Table R401.4.1.

R507.3.2 Minimum depth. Deck footings shall extend below the frost line specified in Table R301.2(1) in accordance with Section R403.1.4.1.

Exceptions:

Freestanding decks that meet all of the following criteria:

- a. The joists bear directly on precast concrete pier blocks at grade without support by beams or posts.
- b. The area of the deck does not exceed 200 square feet (18.9 m²).
- c. The walking surface is not more than 20 inches (514 mm) above grade at any point within 36 inches (914 mm) measured horizontally from the edge.

Reason:

WHAT: This code change provides the specifications for when a freestanding deck can be constructed on precast concrete pier blocks at grade.

WHY: The Deck Code Coalition (DCC) thought it was reasonable to add language to affirm that freestanding decks constructed on precast concrete pier blocks should be allowed. These types of blocks are popular because they are low cost, easy to use and readily available at home improvement stores around the country. The committee did not foresee any safety concerns based on the limitations specified.





The Deck Code Coalition (DCC) is a diverse group of stakeholders, including building officials, industry associations, product manufacturers, design professionals, and academia who have worked since the 2012 IRC code development cycle in an effort to consolidate and improve deck construction methods from across the country.

Our goals are threefold:

1. Consolidate existing code scattered throughout the IRC under the newly expanded Section R507. Being able to easily locate all deck related code provisions in one section equally serves the builder, code official and design professional to a safer, code-conforming deck.
2. Create realistic, fact-based, prescriptive solutions to fill critical gaps in the current deck code. Many parts of existing deck code rely on subjective interpretations by the reader leading to an inconsistent approach to meeting minimum code.
3. Maintain and promote a safer deck structure without unduly burdening the builder. In all cases the DCC want to offer safe minimum requirements without stifling the creativity of the design professional or builder.

Cost Impact: Will not increase the cost of construction

There is no cost impact. The builder was always required to provide deck footings in accordance with Section 4. In fact it might actually reduce the cost by giving prescriptive acceptance for footings on concrete pier blocks.

Report of Committee Action Hearings

Committee Action:

Approved as Submitted

Committee Reason: The committee approved this proposal based on the proponents published reason statement.

Assembly Action:

None

Final Action Results

RB206-16

AS

[←BACK](#)

Code Change No: **RB207-16**

Original Proposal

Section: R507, R507.3 (New), R507.3.1 (New), R507.3.2 (New), TABLE R507.3.1 (New)

Proponent: Charles Bajnai, representing Deck Code Coalition and Chesterfield County, VA; and North American Deck and Railing Association (NADRA) (bajnaic@chesterfield.gov)

Add new text as follows:

R507.3 Footings. Decks shall be supported on concrete footings or other approved structural systems designed to accommodate all loads according to Section R301.

R507.3.1 Minimum size. The minimum size of concrete footings shall be in accordance with Table R507.3.1, based on the tributary area and allowable soil bearing pressure in accordance with Table R401.4.1.

R507.3.2 Minimum depth. Deck footings shall extend below the frost line specified in Table R301.2(1) in accordance with Section R403.1.4.1.

**TABLE TABLE R507.3.1
MINIMUM FOOTING SIZE FOR DECKS**

MINIMUM FOOTING SIZE FOR DECKS ^{a,c,d} (sqft)													
LIVE OR GROUND SNOW LOAD ^b (psf)	TRIBUTARY AREA (sqft)	1500			2000			2500			≥3000		
		Side of a square footing (in)	Diameter of a round footing (in)	Thickness (in)	Side of a square footing (in)	Diameter of a round footing (in)	Thickness (in)	Side of a square footing (in)	Diameter of a round footing (in)	Thickness (in)	Side of a square footing (in)	Diameter of a round footing (in)	Thickness (in)
40	20	12	14	6	12	14	6	12	14	6	12	14	6
	40	14	16	6	12	14	6	12	14	6	12	14	6
	60	17	19	6	15	17	6	13	15	6	12	14	6
	80	20	22	7	17	19	6	15	17	6	14	16	6
	100	22	25	8	19	21	6	17	19	6	15	17	6

	<u>120</u>	<u>24</u>	<u>27</u>	<u>9</u>	<u>21</u>	<u>23</u>	<u>7</u>	<u>19</u>	<u>21</u>	<u>6</u>	<u>17</u>	<u>19</u>	<u>6</u>
	<u>140</u>	<u>26</u>	<u>29</u>	<u>10</u>	<u>22</u>	<u>25</u>	<u>8</u>	<u>20</u>	<u>23</u>	<u>7</u>	<u>18</u>	<u>21</u>	<u>6</u>
	<u>160</u>	<u>28</u>	<u>31</u>	<u>11</u>	<u>24</u>	<u>27</u>	<u>9</u>	<u>21</u>	<u>24</u>	<u>8</u>	<u>20</u>	<u>22</u>	<u>7</u>
50	<u>20</u>	<u>12</u>	<u>14</u>	<u>6</u>	<u>12</u>	<u>14</u>	<u>6</u>	<u>12</u>	<u>14</u>	<u>6</u>	<u>12</u>	<u>14</u>	<u>6</u>
	<u>40</u>	<u>15</u>	<u>17</u>	<u>6</u>	<u>13</u>	<u>15</u>	<u>6</u>	<u>12</u>	<u>14</u>	<u>6</u>	<u>12</u>	<u>14</u>	<u>6</u>
	<u>60</u>	<u>19</u>	<u>21</u>	<u>6</u>	<u>16</u>	<u>18</u>	<u>6</u>	<u>14</u>	<u>16</u>	<u>6</u>	<u>13</u>	<u>15</u>	<u>6</u>
	<u>80</u>	<u>21</u>	<u>24</u>	<u>8</u>	<u>19</u>	<u>21</u>	<u>6</u>	<u>17</u>	<u>19</u>	<u>6</u>	<u>15</u>	<u>17</u>	<u>6</u>
	<u>100</u>	<u>24</u>	<u>27</u>	<u>9</u>	<u>21</u>	<u>23</u>	<u>7</u>	<u>19</u>	<u>21</u>	<u>6</u>	<u>17</u>	<u>19</u>	<u>6</u>
	<u>120</u>	<u>26</u>	<u>30</u>	<u>10</u>	<u>23</u>	<u>26</u>	<u>8</u>	<u>20</u>	<u>23</u>	<u>7</u>	<u>19</u>	<u>21</u>	<u>6</u>
	<u>140</u>	<u>28</u>	<u>32</u>	<u>11</u>	<u>25</u>	<u>28</u>	<u>9</u>	<u>22</u>	<u>25</u>	<u>8</u>	<u>20</u>	<u>23</u>	<u>7</u>
	<u>160</u>	<u>30</u>	<u>34</u>	<u>12</u>	<u>26</u>	<u>30</u>	<u>10</u>	<u>24</u>	<u>27</u>	<u>9</u>	<u>21</u>	<u>24</u>	<u>8</u>
	60	<u>20</u>	<u>12</u>	<u>14</u>	<u>6</u>	<u>12</u>	<u>14</u>	<u>6</u>	<u>12</u>	<u>14</u>	<u>6</u>	<u>12</u>	<u>14</u>
<u>40</u>		<u>16</u>	<u>19</u>	<u>6</u>	<u>14</u>	<u>16</u>	<u>6</u>	<u>13</u>	<u>14</u>	<u>6</u>	<u>12</u>	<u>14</u>	<u>6</u>
<u>60</u>		<u>20</u>	<u>23</u>	<u>7</u>	<u>17</u>	<u>20</u>	<u>6</u>	<u>16</u>	<u>18</u>	<u>6</u>	<u>14</u>	<u>16</u>	<u>6</u>
<u>80</u>		<u>23</u>	<u>26</u>	<u>9</u>	<u>20</u>	<u>23</u>	<u>7</u>	<u>18</u>	<u>20</u>	<u>6</u>	<u>16</u>	<u>19</u>	<u>6</u>
<u>100</u>		<u>26</u>	<u>29</u>	<u>10</u>	<u>22</u>	<u>25</u>	<u>8</u>	<u>20</u>	<u>23</u>	<u>7</u>	<u>18</u>	<u>21</u>	<u>6</u>
<u>120</u>		<u>28</u>	<u>32</u>	<u>11</u>	<u>25</u>	<u>28</u>	<u>9</u>	<u>22</u>	<u>25</u>	<u>8</u>	<u>20</u>	<u>23</u>	<u>7</u>
<u>140</u>		<u>31</u>	<u>35</u>	<u>12</u>	<u>27</u>	<u>30</u>	<u>10</u>	<u>24</u>	<u>27</u>	<u>9</u>	<u>22</u>	<u>24</u>	<u>8</u>
<u>160</u>		<u>33</u>	<u>37</u>	<u>13</u>	<u>28</u>	<u>32</u>	<u>11</u>	<u>25</u>	<u>29</u>	<u>10</u>	<u>23</u>	<u>26</u>	<u>9</u>
70	<u>20</u>	<u>12</u>	<u>14</u>	<u>6</u>	<u>12</u>	<u>14</u>	<u>6</u>	<u>12</u>	<u>14</u>	<u>6</u>	<u>12</u>	<u>14</u>	<u>6</u>
	<u>40</u>	<u>18</u>	<u>20</u>	<u>6</u>	<u>15</u>	<u>17</u>	<u>6</u>	<u>14</u>	<u>15</u>	<u>6</u>	<u>12</u>	<u>14</u>	<u>6</u>
	<u>60</u>	<u>21</u>	<u>24</u>	<u>8</u>	<u>19</u>	<u>21</u>	<u>6</u>	<u>17</u>	<u>19</u>	<u>6</u>	<u>15</u>	<u>17</u>	<u>6</u>
	<u>80</u>	<u>25</u>	<u>28</u>	<u>9</u>	<u>21</u>	<u>24</u>	<u>8</u>	<u>19</u>	<u>22</u>	<u>7</u>	<u>18</u>	<u>20</u>	<u>6</u>
	<u>100</u>	<u>28</u>	<u>31</u>	<u>11</u>	<u>24</u>	<u>27</u>	<u>9</u>	<u>21</u>	<u>24</u>	<u>8</u>	<u>20</u>	<u>22</u>	<u>7</u>
	<u>120</u>	<u>30</u>	<u>34</u>	<u>12</u>	<u>26</u>	<u>30</u>	<u>10</u>	<u>24</u>	<u>27</u>	<u>9</u>	<u>21</u>	<u>24</u>	<u>8</u>
	<u>140</u>	<u>33</u>	<u>37</u>	<u>13</u>	<u>28</u>	<u>32</u>	<u>11</u>	<u>25</u>	<u>29</u>	<u>10</u>	<u>23</u>	<u>26</u>	<u>9</u>
	<u>160</u>	<u>35</u>	<u>40</u>	<u>15</u>	<u>30</u>	<u>34</u>	<u>12</u>	<u>27</u>	<u>31</u>	<u>11</u>	<u>25</u>	<u>28</u>	<u>9</u>

- a. Interpolation permitted, extrapolation not permitted
- b. Based on highest load case: Dead + Live or Dead + Snow
- c. Assumes minimum square footing to be 12" x 12" x 6" for 6x6 post.
- d. If the support is a brick or cmu pier, the footing shall have a minimum 2" projection on all sides.
- e. Area, in square feet, of deck surface supported by post and footing.

Reason:

WHAT: This code change provides prescriptive language and a table for determining the minimum size and depth of deck footings based on tributary area, live load and soil bearing pressure. It provides the size based on either square or cylindrical footings.

WHY: The current code does not address footing size and depth. The information has to be gleaned out of Chapters 3 and 4. The Deck Code Coalition (DCC) thought a prescriptive table would be easier for deck builders – especially for homeowners who would not know how to calculate the size based on live load and soil's load bearing pressure.

Example:

Based on a typical 12'x 12" deck with two posts away from the house and a 40 psf live/snow load,

and 2000 psf soil bearing pressure:

Tributary area = $(1/4) \times 12' \times 12' = 36 \text{ sqft. @ } 2000 \text{ psf}$

Table says footing to be 12" x 12" x 6" (square) or 14" diameter (cylinder)



The Deck Code Coalition (DCC) is a diverse group of stakeholders, including building officials, industry associations, product manufacturers, design professionals, and academia who have worked since the 2012 IRC code development cycle in an effort to consolidate and improve deck construction methods from across the country.

Our goals are threefold:

1. Consolidate existing code scattered throughout the IRC under the newly expanded Section R507. Being able to easily locate all deck related code provisions in one section equally serves the builder, code official and design professional to a safer, code-conforming deck.
2. Create realistic, fact-based, prescriptive solutions to fill critical gaps in the current deck code. Many parts of existing deck code rely on subjective interpretations by the reader leading to an inconsistent approach to meeting minimum code.
3. Maintain and promote a safer deck structure without unduly burdening the builder. In all cases the DCC want to offer safe minimum requirements without stifling the creativity of the design professional builder.

MINIMUM FOOTING SIZE for DECKS * * * (sqft)													
LIVE or GROUND SNOW LOAD * (psf)	TRIBUTARY AREA * (sqft)	SOIL BEARING CAPACITY (psf)											
		1500			2000			2500			>3000		
		side of a square footing (in)	diameter of a round footing (in)	thickness (in)	side of a square footing (in)	diameter of a round footing (in)	thickness (in)	side of a square footing (in)	diameter of a round footing (in)	thickness (in)	side of a square footing (in)	diameter of a round footing (in)	thickness (in)
40	20	12	14	6	12	14	6	12	14	6	12	14	6
	40	14	16	6	12	14	6	12	14	6	12	14	6
	60	17	19	6	15	17	6	13	15	6	12	14	6
	80	20	22	7	17	19	6	15	17	6	14	16	6
	100	22	25	8	19	21	6	17	19	6	15	17	6
	120	24	27	9	21	23	7	19	21	6	17	19	6
	140	26	29	10	22	25	8	20	23	7	18	21	6
50	20	12	14	6	12	14	6	12	14	6	12	14	6
	40	15	17	6	13	15	6	12	14	6	12	14	6
	60	19	21	6	16	18	6	14	16	6	13	15	6
	80	21	24	8	19	21	6	17	19	6	15	17	6
	100	24	27	9	21	23	7	19	21	6	17	19	6
	120	26	30	10	23	26	8	20	23	7	19	21	6
	140	28	32	11	25	28	9	22	25	8	20	23	7
60	20	12	14	6	12	14	6	12	14	6	12	14	6
	40	16	19	6	14	16	6	13	14	6	12	14	6
	60	20	23	7	17	20	6	16	18	6	14	16	6
	80	23	26	9	20	23	7	18	20	6	16	19	6
	100	26	29	10	22	25	8	20	23	7	18	21	6
	120	28	32	11	25	28	9	22	25	8	20	23	7
	140	31	35	12	27	30	10	24	27	9	22	24	8
70	20	12	14	6	12	14	6	12	14	6	12	14	6
	40	18	20	6	15	17	6	14	15	6	12	14	6
	60	21	24	8	19	21	6	17	19	6	15	17	6
	80	25	28	9	21	24	8	19	22	7	18	20	6
	100	28	31	11	24	27	9	21	24	8	20	22	7
	120	30	34	12	26	30	10	24	27	9	21	24	8
	140	33	37	13	28	32	11	25	29	10	23	26	9

Cost Impact: Will not increase the cost of construction
 If deck footings were correctly sized in the past, there will not be a cost increase based on this table.

Report of Committee Action Hearings

Committee Action: **Approved as Submitted**

Committee Reason: The committee approved this proposal based on the proponents published reason statement.

Assembly Action: **None**

Final Action Results

RB207-16 AS

[←BACK](#)

[←BACK](#)

Code Change No: **RB208-16**

Original Proposal

Section: R507, R507.3 (New), R507.3.1 (New), R507.3.2 (New)

Proponent: Charles Bajnai, representing Deck Code Coalition and Chesterfield County, VA; and North American Deck and Railing Association (NADRA) (bajnaic@chesterfield.gov)

Add new text as follows:

R507.3 Footings. Decks shall be supported on concrete footings or other approved structural systems designed to accommodate all loads according to Section R301.

R507.3.1 Minimum size. The minimum size of concrete footings shall be in based on the tributary area and allowable soil bearing pressure in accordance with Table R401.4.1.

R507.3.2 Minimum depth. Deck footings shall extend below the frost line specified in Table R301.2(1) in accordance with Section R403.1.4.1.

Exception: Freestanding decks need not be provided with footings that extend below the frost line.

Reason:

WHAT: This code change provides prescriptive language for where the minimum size and depth of deck footings can be found, namely in Chapter 4.

It also copies an exception from R403.1.4, that says freestanding decks, i.e. "Decks not supported by a dwelling" do not require the footings to be below the frost line.

WHY: The Deck Code Coalition (DCC) thought the deck builder should know where to look for footing size and depth information. The DCC thought it was important to have all of the deck related information in R507.

The Deck Code Coalition (DCC) is a diverse group of stakeholders, including building officials, industry associations, product manufacturers, design professionals, and academia who have worked since the 2012 IRC code development cycle in an effort to consolidate and improve deck construction methods from across the country. Our goals are threefold:

1. Consolidate existing code scattered throughout the IRC under the newly expanded Section R507. Being able to easily locate all deck related code provisions in one section equally serves the builder, code official and design professional to a safer, code-conforming deck.
2. Create realistic, fact-based, prescriptive solutions to fill critical gaps in the current deck code. Many parts of existing deck code rely on subjective interpretations by the reader leading to an inconsistent approach to meeting minimum code.
3. Maintain and promote a safer deck structure without unduly burdening the builder. In all cases the DCC want to offer safe minimum requirements without stifling the creativity of the design professional or builder.

Cost Impact: Will not increase the cost of construction

There will not be a cost impact. This code change does not alter the way deck footings have been sized under the current code.

Report of Committee Action Hearings

Committee Action:

Approved as Submitted

Committee Reason: The committee approved this proposal based on the proponents published reason statement.

Assembly Action:

None

Final Action Results

RB208-16

AS

[←BACK](#)

Code Change No: **RB209-16**

Original Proposal

Section(s): R507, R507.4

Proponent: Charles Bajnai, representing Deck Code Coalition and Chesterfield County, VA; and North American Deck and Railing Association (NADRA) (bajnaic@chesterfield.gov)

Revise as follows:

SECTION R507 EXTERIOR DECKS

R507.4R507.7 Decking. Maximum allowable spacing for joists supporting decking shall be in accordance with Table ~~R507.4~~R507.7. Wood decking shall be attached to each supporting member with not less than (2) 8d threaded nails or (2) No. 8 wood screws. Other types of decking or fastener systems shall be permitted in accordance with manufacturer's installation requirements.

**TABLE ~~R507.4~~ R507.7
MAXIMUM JOIST SPACING FOR DECKING**

DECKING MATERIAL TYPE AND NOMINAL SIZE	MAXIMUM ON-CENTER JOIST SPACING	
	<u>Decking perpendicular to joist</u>	<u>Decking diagonal to joist^a</u>
1 ¹ / ₄ -inch-thick wood	16 inches	12 inches
2-inch-thick wood	24 inches	16 inches
Plastic composite	In accordance with Section R507.3	In accordance with Section R507.3

For SI: 1 inch = 25.4 mm, 1 foot = 304.8 mm, 1 degree = 0.01745 rad.

a. Maximum angle of 45 degrees from perpendicular for wood deck boards

Reason:

WHAT: This code change modifies the decking text to permit custom decking materials and custom fasteners.

WHY: The Deck Code Coalition (DCC) thought it was imperative to permit all of the new decking materials being developed over the past few years. Also the market has seen many new fasteners and fastening systems being developed.



The Deck Code Coalition (DCC) is a diverse group of stakeholders, including building officials, industry associations, product manufacturers, design professionals, and academia who have worked since the 2012 IRC code development cycle in an effort to consolidate and improve deck construction methods from across the country.

Our goals are threefold:

1. Consolidate existing code scattered throughout the IRC under the newly expanded Section R507. Being able to easily locate all deck related code provisions in one section equally serves the builder, code official and design professional to a safer, code-conforming deck.
2. Create realistic, fact-based, prescriptive solutions to fill critical gaps in the current deck code. Many parts of existing deck code rely on subjective interpretations by the reader leading to an inconsistent approach to meeting minimum code.
3. Maintain and promote a safer deck structure without unduly burdening the builder. In all cases the DCC want to offer safe minimum requirements without stifling the creativity of the design professional or builder.

Cost Impact: Will not increase the cost of construction

There is no cost impact. It may even save a bit by allowing proprietary fastening systems.

Report of Committee Action Hearings

Committee Action:

Approved as Submitted

Committee Reason: The committee felt this is a good update to this section as it allows alternative decking material and fastener systems.

Assembly Action:

None

Public Comments

Public Comment 1:

Paul Coats, PE CBO (pcoats@awc.org) requests Approve as Modified by this Public Comment.

Modify as follows:

R507.7 Decking. Maximum allowable spacing for joists supporting decking shall be in accordance with Table R507.7. Wood decking shall be attached to each supporting member with not less than (2) 8d threaded nails or (2) No. 8 wood screws. Other types of ~~approved~~ decking or fastener systems shall be ~~permitted~~ installed in accordance with manufacturer's installation requirements.

Commenter's Reason: The phrase "shall be permitted" is overly broad in this instance because there are no specific performance requirements for the alternative decking or fastener system. The proposed revisions add "approved" to clarify that the alternative decking or fastener system is subject to approval by the building official as are all alternative systems. Revisions also clarify that installation shall be per manufacturer's installation instructions.

Final Action Results

RB209-16

AMPC1

[←BACK](#)

[←BACK](#)

Code Change No: **RB210-16**

Original Proposal

Section: R507, R507.5, R507.5.1, R507.7

Proponent: Charles Bajnai, representing Deck Code Coalition and Chesterfield County, VA; and North American Deck and Railing Association (NADRA) (bajnaic@chesterfield.gov)

Revise as follows:

~~R507.5~~ **R507.6 Deck joists.** Maximum allowable spans for wood deck joists, as shown in Figure ~~R507.5~~ **R507.6**, shall be in accordance with Table ~~R507.5~~ **R507.6**. ~~Deck joists~~ The maximum joist spacing shall be permitted to be limited by the decking material in accordance with Table R507.4. The maximum joist cantilever not greater than one-fourth of shall be limited to the actual, adjacent joist span divided by 4 or the maximum cantilever length specified in Table R507.6, whichever is less.

~~R507.7~~ **R507.6.1 Deck joist and deck beam bearing.** The ends of ~~each joist and beam joists~~ shall have not less than $1\frac{1}{2}$ inches (38 mm) of bearing on wood or metal and not less than 3 inches (76 mm) on concrete or masonry ~~for the over its entire width.~~ Joists bearing on top of the a multi-ply beam or ledger shall be fastened in accordance with Table R602.3(1). Joists bearing on top of a single ply beam or ledger shall be attached by a mechanical connector. Joist framing into the side of a beam or ledger board or beam shall be supported by approved joist hangers. Joists bearing on a beam shall be connected to the beam to resist lateral displacement.

~~R507.5.1~~ **R507.6.2 Lateral Deck joist lateral restraint at supports.** Joist ends and bearing locations shall be provided with lateral restraint to prevent rotation. Where lateral restraint is provided by joist hangers or blocking between joists, their depth shall equal not less than 60 percent of the joist depth. Where lateral restraint is provided by rim joists, they shall be secured to the end of each joist with not less than (3) 10d (3-inch x 0.128-inch) nails or (3) No. 10 x 3-inch (76 mm) long wood screws.

TABLE ~~R507.5~~ R507.6
DECK JOIST SPANS FOR COMMON LUMBER SPECIES^{fb} (ft. - in.)

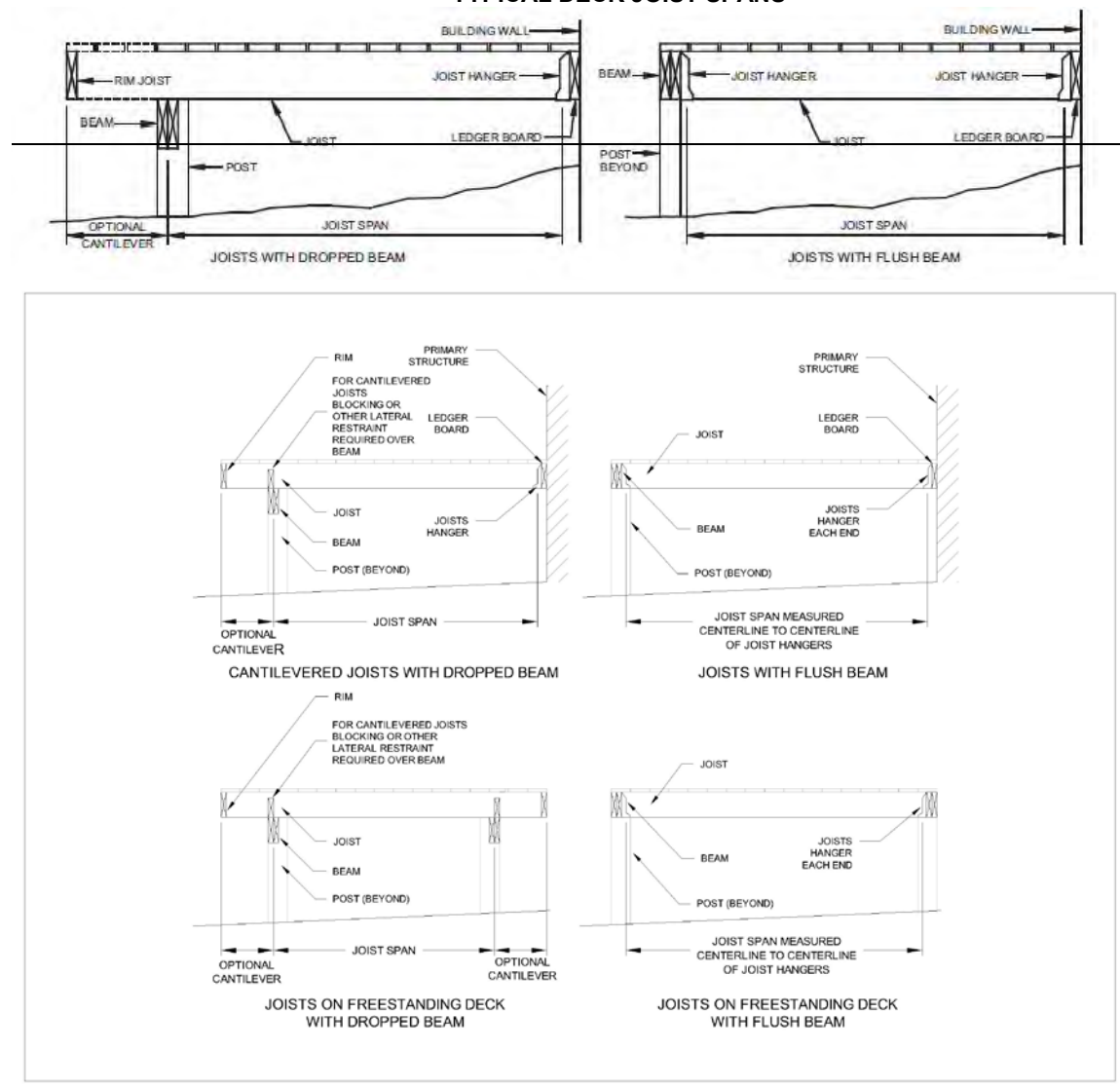
SPECIES ^a	SIZE	ALLOWABLE JOIST SPAN ^c			MAXIMUM CANTILEVER ¹		
		SPACING OF DECK JOISTS WITH NO CANTILEVER ^{b,f} (inches)			SPACING OF DECK JOISTS WITH CANTILEVERS ^c (inches)		
		12	16	24	12	16	24
Southern pine	2 x 6	9-11	9-0	7-7	<u>1-3</u>	<u>1-4</u>	<u>1-6</u>
	2 x 8	13-1	11-10	9-8	<u>2-1</u>	<u>2-3</u>	<u>2-5</u>
	2 x 10	16-2	14-0	11-5	<u>3-4</u>	<u>3-6</u>	<u>2-10</u>
	2 x 12	18-0	16-6	13-6	<u>4-6</u>	<u>4-2</u>	<u>3-4</u>
Douglas fir-larch ^d , hem-fir ^d , spruce-pine-fir ^d	2 x 6	9-6	8-8	7-2	<u>1-2</u>	<u>1-3</u>	<u>1-5</u>
	2 x 8	12-6	11-1	9-1	<u>1-11</u>	<u>2-1</u>	<u>2-3</u>
	2 x 10	15-8	13-7	11-1	<u>3-1</u>	<u>3-5</u>	<u>2-9</u>
	2 x 12	18-0	15-9	12-10	<u>4-6</u>	<u>3-11</u>	<u>3-3</u>

Redwood, western cedars, ponderosa pine ^e , red pine ^e	2 x 6	8-10	8-0	7-0	1-0	1-1	1-2
	2 x 8	11-8	10-7	8-8	1-8	1-10	2-0
	2 x 10	14-11	13-0	10-7	2-8	2-10	2-8
	2 x 12	17-5	15-1	12-4	3-10	3-9	3-1

For SI: 1 inch = 25.4 mm, 1 foot = 304.8 mm, 1 pound per square foot = 0.0479 kPa, 1 pound = 0.454 kg.

- a. No. 2 grade with wet service factor.
- b. Ground snow load, live load = 40 psf, dead load = 10 psf, $L/\Delta = 360$.
- c. Ground snow load, live load = 40 psf, dead load = 10 psf, $L/\Delta = 360$ at main span, $L/\Delta = 180$ at cantilever with a 220-pound point load applied to end.
- d. Includes incising factor.
- e. Northern species with no incising factor
- f. Cantilevered spans not exceeding the nominal depth of the joist are permitted.

**FIGURE R507.5-R507.6
TYPICAL DECK JOIST SPANS**



Reason:**WHAT:** This code change

1. Modifies the joist text, and
2. Replaces the figure, and
3. Amends the table.

WHY: The Deck Code Coalition (DCC) wanted to make several changes the this part of the code. They include:

1. The way cantilever lengths were displayed in the table. The current table is difficult to understand, and this revision more clearly explains the two limitations, namely cantilevers are limited to joist span divided by 4 or the lengths in the table, whichever is the lessor.
2. The figure was changed because the committee thought it was worthwhile to include freestanding decks in the picture, and show lateral support over the beams.
3. Splitting the beam and joist text that currently are in the same paragraph (R507.7.) regarding support and lateral restraint. The beam part of this was done by a different code submittal; this code change is for the joists.



The Deck Code Coalition (DCC) is a diverse group of stakeholders, including building officials, industry associations, product manufacturers, design professionals, and academia who have worked since the 2012 IRC code development cycle in an effort to consolidate and improve deck construction methods from across the country.

Our goals are threefold:

1. Consolidate existing code scattered throughout the IRC under the newly expanded Section R507. Being able to easily locate all deck related code provisions in one section equally serves the builder, code official and design professional to a safer, code-conforming deck.
2. Create realistic, fact-based, prescriptive solutions to fill critical gaps in the current deck code. Many parts of existing deck code rely on subjective interpretations by the reader leading to an inconsistent approach to meeting minimum code.
3. Maintain and promote a safer deck structure without unduly burdening the builder. In all cases the DCC want to offer safe minimum requirements without stifling the creativity of the design professional or builder.

Cost Impact: Will not increase the cost of construction

There is no cost impact. It could allow for longer cantilevers in some situations.

Report of Committee Action Hearings

Committee Action:

Approved as Submitted

Committee Reason: The committee approved this proposal based on the proponents published reason statement. This change provides clarity for freestanding decks.

Assembly Action:

None

Final Action Results

RB210-16

AS

[←BACK](#)

[←BACK](#)

Code Change No: **RB212-16**

Original Proposal

Section: R507, R507.8, R507.8.1

Proponent: Charles Bajnai, representing Deck Code Coalition and Chesterfield County, VA; and North American Deck and Railing Association (NADRA) (bajnaic@chesterfield.gov)

Revise as follows:

~~R507.8~~ R507.4 Deck posts. For single-level wood-framed decks with beams sized in accordance with Table R507.6, deck post size shall be in accordance with Table ~~R507.8~~R507.4.

TABLE ~~R507.8~~ R507.4
DECK POST HEIGHT^a

DECK POST SIZE	MAXIMUM HEIGHT ^{a, b}
4 × 4	6'-9" ^c
4 × 6	8'
6 × 6	14'
<u>8 × 8</u>	<u>14'</u>

For SI: 1 foot = 304.8 mm.

a. Measured to the underside of the beam.

b. Based on 40 psf live load.

c. The maximum permitted height is 8'-0" for one-ply and two-ply beams. 6'-9" is the maximum permitted height for three-ply beams on post cap.

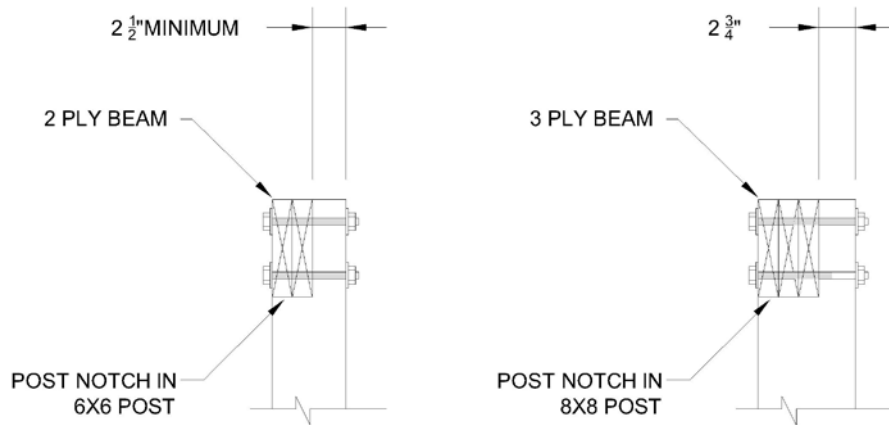
~~R507.8.1~~ R507.4.1 Deck post to deck footing connection. Posts shall bear on footings in accordance with Section R403 and Figure ~~R507.8.1~~R507.4.1. Posts shall be restrained to prevent lateral displacement at the bottom support. Such lateral restraint shall be provided by manufactured connectors installed in accordance with Section R507 and the manufacturers' instructions or a minimum post embedment of 12 inches (305 mm) in surrounding soils or concrete piers.

FIGURE ~~R507.8.1~~ R507.4.1
TYPICAL DECK POSTS TO DECK FOOTINGS
(Existing code figure not shown for clarity)

Reason:

WHAT: This code proposal relocates the deck post section. Also, it adds 8x8 posts to the table.

WHY: The Deck Code Coalition (DCC) thought it was necessary to add 8x8 posts to the table because three ply beams cannot be supported by notched 6x6 posts – that is, they require 2 1/2" wide support leg which can only be achieved with a 8x8 post.



The Deck Code Coalition (DCC) is a diverse group of stakeholders, including building officials, industry associations, product manufacturers, design professionals, and academia who have worked since the 2012 IRC code development cycle in an effort to consolidate and improve deck construction methods from across the country. Our goals are threefold:

1. Consolidate existing code scattered throughout the IRC under the newly expanded Section R507. Being able to easily locate all deck related code provisions in one section equally serves the builder, code official and design professional to a safer, code-conforming deck.
2. Create realistic, fact-based, prescriptive solutions to fill critical gaps in the current deck code. Many parts of existing deck code rely on subjective interpretations by the reader leading to an inconsistent approach to meeting minimum code.
3. Maintain and promote a safer deck structure without unduly burdening the builder. In all cases the DCC want to offer safe minimum requirements without stifling the creativity of the design professional or builder.

Cost Impact: Will not increase the cost of construction
There is no cost impact. This proposal adds more options to the table.

Report of Committee Action Hearings

Committee Action:

Approved as Submitted

Committee Reason: The committee approved this proposal based on the proponents published reason statement.

Assembly Action:

None

Final Action Results

RB212-16

AS

[←BACK](#)

[←BACK](#)

Code Change No: **RB213-16**

Original Proposal

Section: R507.8, R507.8.1

Proponent: Charles Bajnai, representing Deck Code Coalition and Chesterfield County, VA; and North American Deck and Railing Association (NADRA) (bajnaic@chesterfield.gov)

Revise as follows:

~~R507.8~~ R507.4 Deck posts. For single-level wood-framed decks with beams sized in accordance with Table R507.6, deck post size shall be in accordance with Table ~~R507.8~~ R507.4.

TABLE ~~R507.8~~ R507.4
DECK POST HEIGHT^a

DECK POST SIZE	MAXIMUM HEIGHT ^a
4 × 4	8'
4 × 6	8'
6 × 6	14'

For SI: 1 foot = 304.8 mm.

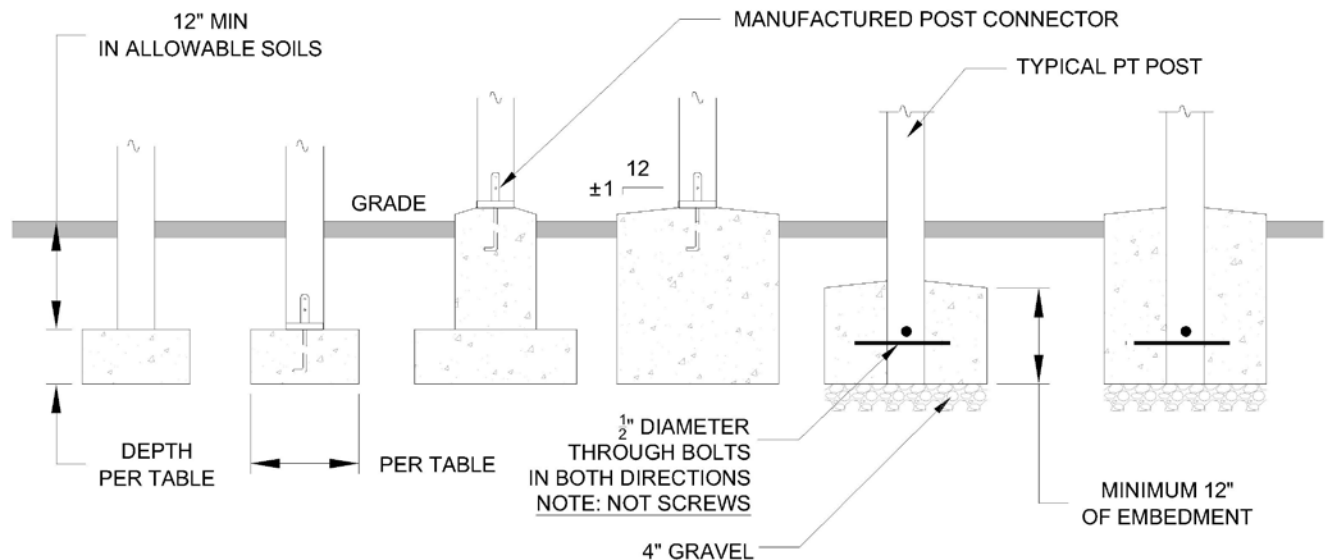
a. Measured to the underside of the beam.

~~R507.8.1~~ R507.4.1 Deck post to deck footing. Posts shall bear on footings in accordance with Section R403 and Figure ~~R507.8.1~~ R507.4.1. Posts shall be restrained to prevent lateral displacement at the bottom support. Such lateral restraint shall be provided by manufactured connectors installed in accordance with Section R507 and the manufacturers' instructions or a minimum post embedment of 12 inches (305 mm) in surrounding soils or concrete piers.

Exception: Where expansive, compressible, shifting or other questionable soils are present, surrounding soils shall not be relied upon for lateral support.

FIGURE R507-8.1 R507.4.1
(TYPICAL DECK POSTS TO DECK FOOTINGS)

(Existing code figure not shown for clarity)



NOTE:
 POSTS MUST BE CENTERED ON OR IN FOOTING

Reason:

WHAT:

1. This code proposal relocates the deck post section.
2. It also adds an exception that says deck posts cannot use embedded soil for lateral support if the surrounding soils are problematic.
3. The figure was changed to better reflect how the connection between the deck post and the footing is supposed to be.

WHY:

1. Based on the Deck Code Coalition's experience, they did not think that embedding posts 12" in surrounding soil would adequately prevent lateral displacement of the deck post for all situations. The exception was added to cover deck posts in problematic soils.
2. The committee did not think that the existing figure was accurate or depicted how the connection between the post and the footing was supposed to work. The first two existing figures shows posts just sitting on a concrete piers without any lateral restraint - connector.

The Deck Code Coalition (DCC) is a diverse group of stakeholders, including building officials, industry associations, product manufacturers, design professionals, and academia who have worked since the 2012 IRC code development cycle in an effort to consolidate and improve deck construction methods from across the country.

Our goals are threefold:

1. Consolidate existing code scattered throughout the IRC under the newly expanded Section R507. Being able to easily locate all deck related code provisions in one section equally serves the builder, code official and design professional to a safer, code-conforming deck.
2. Create realistic, fact-based, prescriptive solutions to fill critical gaps in the current deck code. Many parts of existing deck code rely on subjective interpretations by the reader leading to an inconsistent approach to meeting minimum code.
3. Maintain and promote a safer deck structure without unduly burdening the builder. In all cases the DCC want to offer safe minimum requirements without stifling the creativity of the design professional or builder.

Cost Impact: Will not increase the cost of construction

There is no cost impact. The code already requires lateral restraint at the bottom of the footings.

**Report of Committee Action
Hearings**

Committee Action:

Approved as Submitted

Committee Reason: This proposal adds a needed change that prohibits certain soils surrounding the deck post from providing the lateral support at the bottom.

Assembly Action:

None

Final Action Results

RB213-16

AS

[←BACK](#)

Code Change No: RB214-16

Original Proposal

Section: R507, R507.8, R507.8.1

Proponent: Charles Bajnai, representing Deck Code Coalition and Chesterfield County, VA; and North American Deck and Railing Association (NADRA) (bajnaic@chesterfield.gov)

Revise as follows:

~~R507.8~~ R507.4 Deck posts. For single-level wood-framed decks with beams sized in accordance with Table R507.6, deck post size shall be in accordance with Table ~~R507.8~~ R507.4.

**TABLE ~~R507.8~~ R507.4
DECK POST HEIGHT^a**

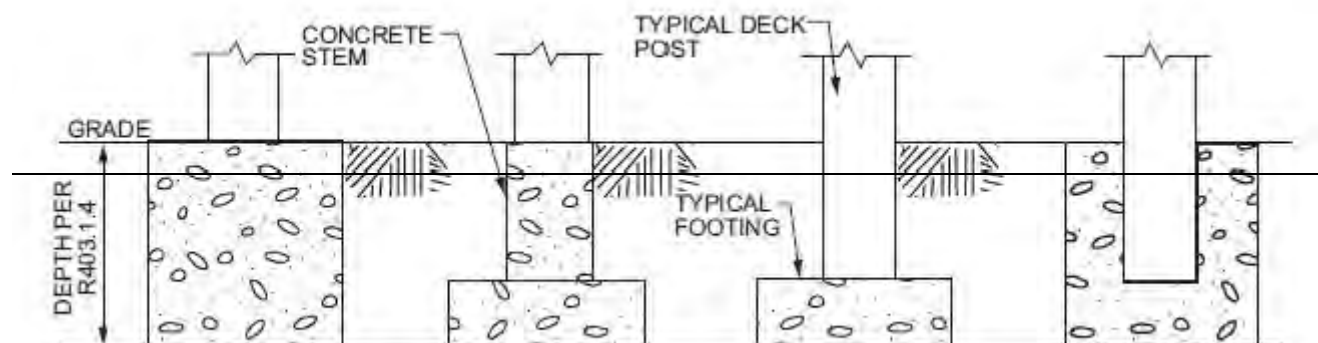
DECK POST SIZE	MAXIMUM HEIGHT ^a
4 × 4	8'
4 × 6	8'
6 × 6	14'

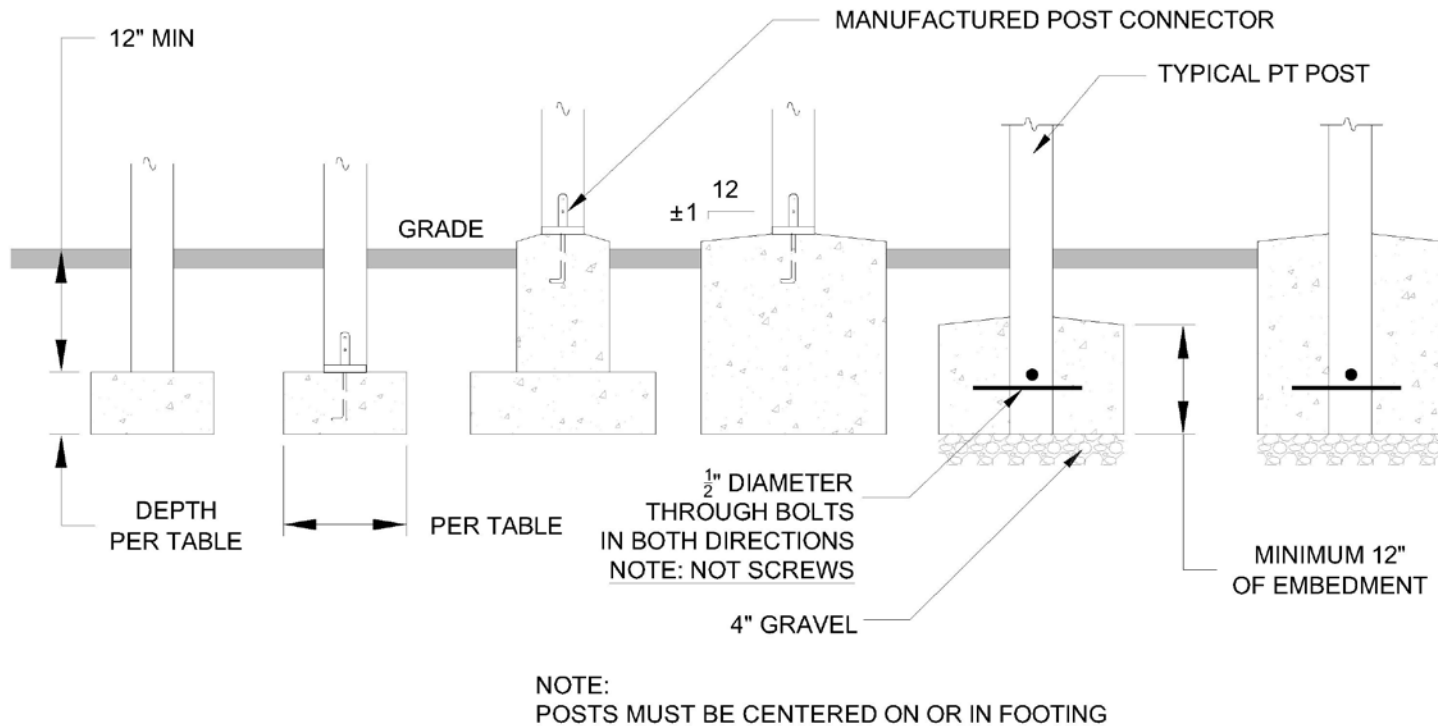
For SI: 1 foot = 304.8 mm.

a. Measured to the underside of the beam.

~~R507.8.1~~ R507.4.1 Deck post to deck footing connection. Posts shall bear on footings in accordance with Section R403 and Figure R507.8.1. Posts shall be restrained to prevent lateral displacement at the bottom support. ~~Such~~ Where posts bear on concrete footings in accordance with Section R403 and Figure R507.4.1, such lateral restraint shall be provided by manufactured connectors installed in accordance with Section R507 and the manufacturers' instructions or a minimum post embedment of 12 inches (305 mm) in surrounding soils or concrete piers. Other footing systems shall be permitted.

**FIGURE ~~R507.8.1~~ R507.4.1
TYPICAL DECK POSTS TO DECK FOOTINGS ~~Deck post to deck footing connection.~~**





Reason:

WHAT:

1. This code change eliminates the wording that posts have to bear on footings. The new wording specifically allows new proprietary footing systems which may or may not have footing per se.
2. This code change also provides a better drawing of how posts are to be attached to footings.

WHY:

1. The Deck Code Coalition (DCC) thought the current deck post to footing figure did not adequately depict how the lateral restraint at the bottom of the post was achieved.
2. The DCC also thought that the wording was too restrictive in that it required all deck posts to bear on concrete footings. The committee did not want to limit options on how to support a deck post; there are new methods, such as helical piers and other new products that can do the job as well.





The Deck Code Coalition (DCC) is a diverse group of stakeholders, including building officials, industry associations, product manufacturers, design professionals, and academia who have worked since the 2012 IRC code development cycle in an effort to consolidate and improve deck construction methods from across the country.

Our goals are threefold:

1. Consolidate existing code scattered throughout the IRC under the newly expanded Section R507. Being able to easily locate all deck related code provisions in one section equally serves the builder, code official and design professional to a safer, code-conforming deck.
2. Create realistic, fact-based, prescriptive solutions to fill critical gaps in the current deck code. Many parts of existing deck code rely on subjective interpretations by the reader leading to an inconsistent approach to meeting minimum code.
3. Maintain and promote a safer deck structure without unduly burdening the builder. In all cases the DCC want to offer safe minimum requirements without stifling the creativity of the design professional or builder.

Cost Impact: Will not increase the cost of construction

There is no cost impact. The code already requires lateral restraint at the bottom of the footings. It may actually reduce the cost by allowing optional proprietary footing systems.

Report of Committee Action Hearings
--

Committee Action:

Approved as Submitted

Committee Reason: The committee approved this proposal based on the proponents published reason statement. Also, it allows alternate methods to be used for deck footings.

Assembly Action:

None

Final Action Results

RB214-16

AS

[←BACK](#)

Code Change No: **RB217-16**

Original Proposal

Section(s): R602.1.11 (New), R610.10, R610.10.1, R610.2, R610.3, R610.3.1, R610.3.2, R610.3.3, R610.3.4, R610.3.5, R610.3.6, R610.4, R610.4.1, R610.5, R610.5.1, R610.5.2, R610.5.3, R610.5.3 (New), R610.5.4 (New), R610.5.6 (New), R610.6, R610.7, R610.8, R610.9

Proponent: Edward Keith, representing APA- The Engineered Wood Association
(ed.keith@apawood.org)

Add new text as follows:

R602.1.11 Structural insulated panels. Structural insulated panels shall be manufactured and identified in accordance with ANSI/APA PRS 610.1

Revise as follows:

R610.2 Applicability limits. The provisions of this section shall control the construction of exterior structural insulated panel walls and interior load-bearing structural insulated panel walls for buildings not greater than 60 feet (18 288 mm) in length perpendicular to the joist or truss span, not greater than 40 feet (12 192 mm) in width parallel to the joist or truss span and not greater than two stories in height with each wall not greater than 10 feet (3048 mm) high. Exterior walls installed in accordance with the provisions of this section shall be considered as load-bearing walls. Structural insulated panel walls constructed in accordance with the provisions of this section shall be limited to sites where the ultimate design wind speed (V_{ult}) is not greater than 155 miles per hour (69 m/s), Exposure B or 140 miles per hour (63 m/s) Exposure C, the ground snow load is not greater than 70 pounds per square foot (3.35 kPa), and the seismic design category is A, B or C.

R610.3.4

~~MINIMUM PROPERTIES FOR POLYURETHANE INSULATION USED AS SIPS CORE~~

For SI: 1 pound per cubic foot = 16.02 kg/m³, 1 pound per square inch = 6.895 kPa, °C = [(°F) - 32]1.8.

Delete without substitution:

~~**R610.3.2 Facing.** Facing materials for SIPs shall be wood structural panels conforming to DOC PS 1 or DOC PS 2, each having a minimum nominal thickness of 7/16 inch (11 mm) and shall meet the additional minimum properties specified in Table R610.3.2. Facing shall be identified by a grade mark or certificate of inspection issued by an approved agency.~~

R610.3.2

~~MINIMUM PROPERTIES^a FOR ORIENTED STRAND BOARD FACER MATERIAL IN SIP WALLS~~

For SI: 1 inch = 25.4 mm, 1 lbf-in²/ft = 9.415 × 10⁻⁶ kPa/m, 1 lbf-in/ft = 3.707 × 10⁻⁴ kN/m, 1 lbf/ft = 0.0146 N/mm, 1 pound per cubic foot = 16.018 kg/m³.

a. Values listed in Table R610.3.2 are qualification test values and are not to be used for design purposes.

b. Mean test value shall be in accordance with Section 7.6 of DOC PS 2.

c. Characteristic test value (5th percent with 75% confidence).

d.—Density shall be based on oven-dry weight and oven-dry volume.

R610.3.3 Adhesive. Adhesives used to structurally laminate the foam plastic insulation core material to the structural wood facers shall conform to ASTM D 2559 or approved alternative specifically intended for use as an adhesive used in the lamination of structural insulated panels. Each container of adhesive shall bear a label with the adhesive manufacturer's name, adhesive name and type and the name of the quality assurance agency.

R610.3.4 R610.3.2 Lumber. No change to text.

Revise as follows:

R610.3.5 R610.3.3 SIP screws. No change to text.

R610.3.6 R610.3.4 Nails. No change to text.

R610.4 SIP wall panels. SIPs shall comply with Figure R610.4 and shall have minimum panel thickness in accordance with Tables R610.5(1) and R610.5(2) for above-grade walls. SIPs shall be identified by grade mark or certificate of inspection issued by an *approved agency in accordance with ANSI/APA PRS 610.1*.

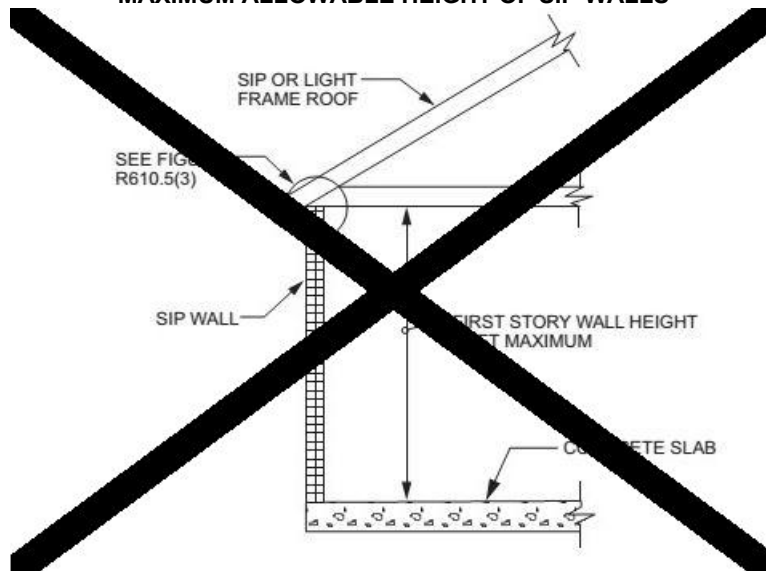
Delete without substitution:

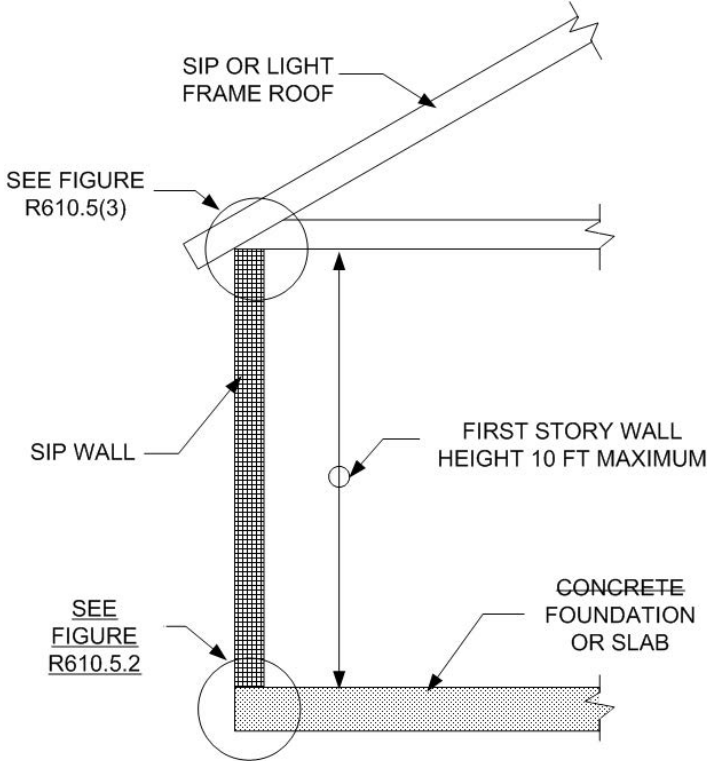
R610.4.1 Labeling. Panels shall be identified by grade mark or certificate of inspection issued by an approved agency. Each (SIP) shall bear a stamp or label with the following minimum information:

1. Manufacturer name/logo.
2. Identification of the assembly.
3. Quality assurance agency.

Delete and substitute as follows:

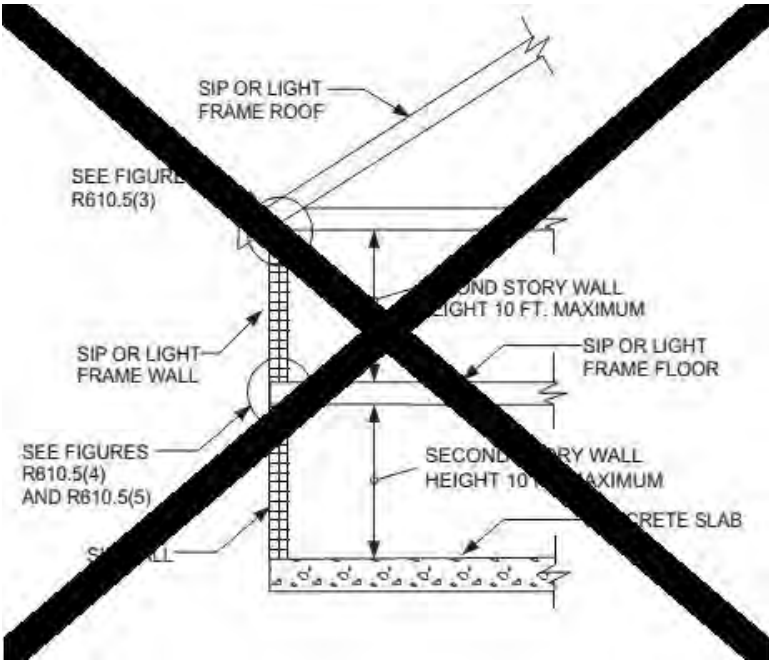
**FIGURE R610.5 (1)
MAXIMUM ALLOWABLE HEIGHT OF SIP WALLS**

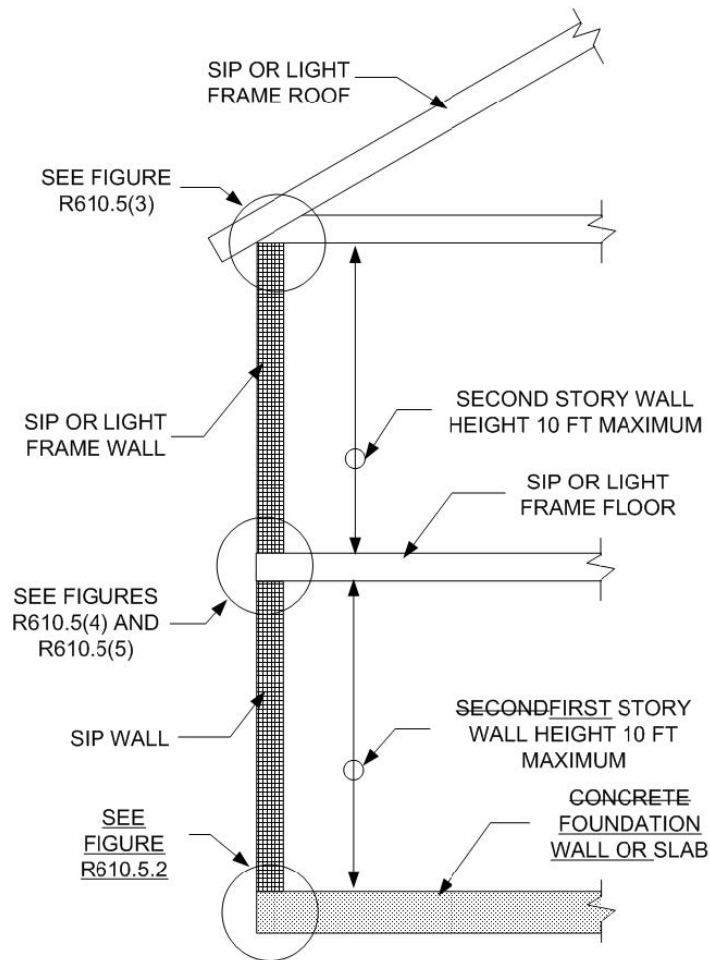




For SI: 1 foot = 304.8 mm.

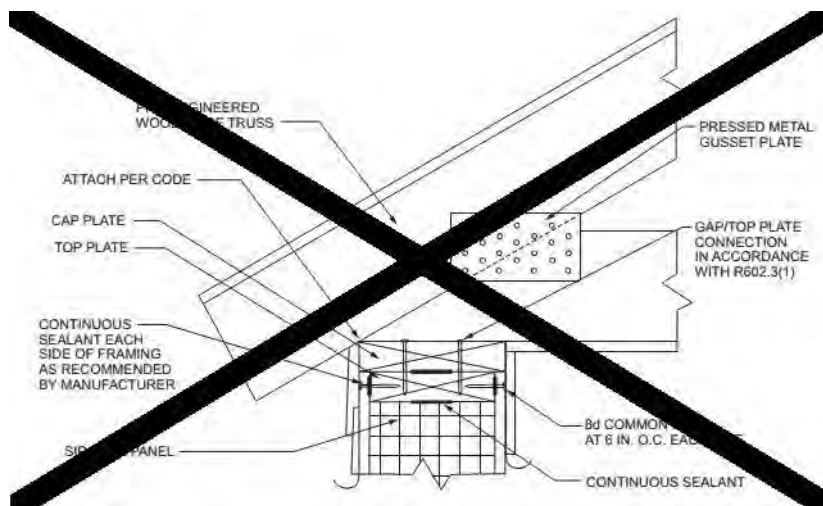
**FIGURE R610.5 (2)
MAXIMUM ALLOWABLE HEIGHT OF SIP WALLS**

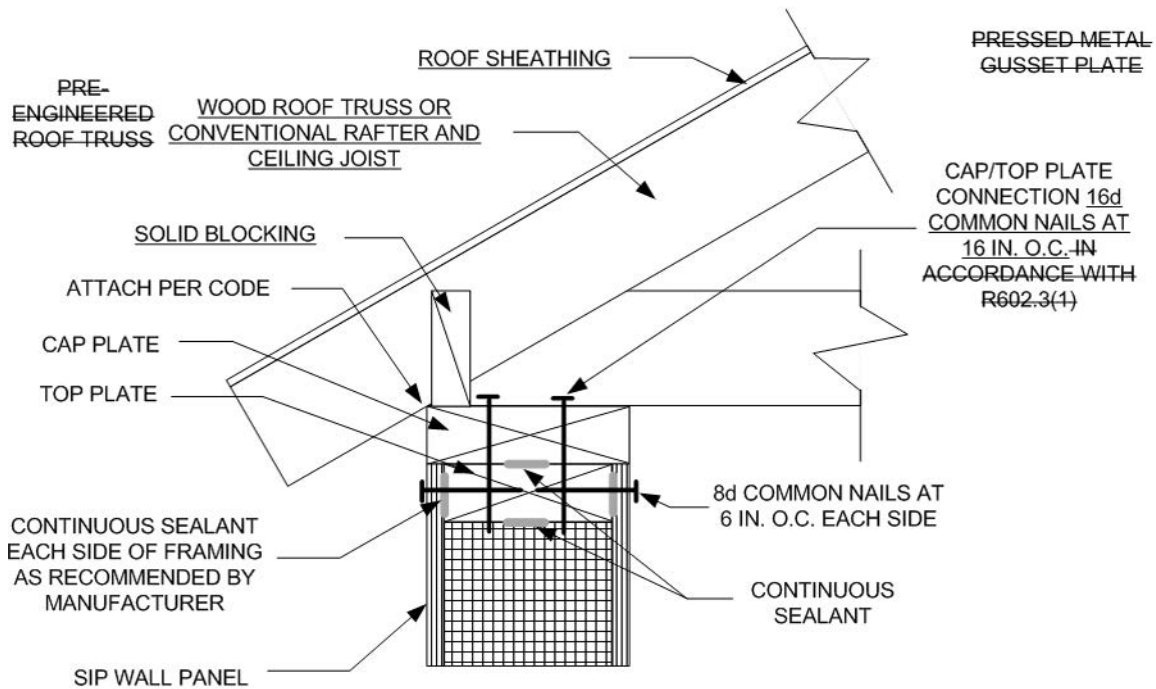




For SI: 1 inch = 25.4 mm

FIGURE R610.5 (3)
TRUSSED ROOF TRUSS OR CONVENTIONAL RAFTER TO TOP PLATE CONNECTION

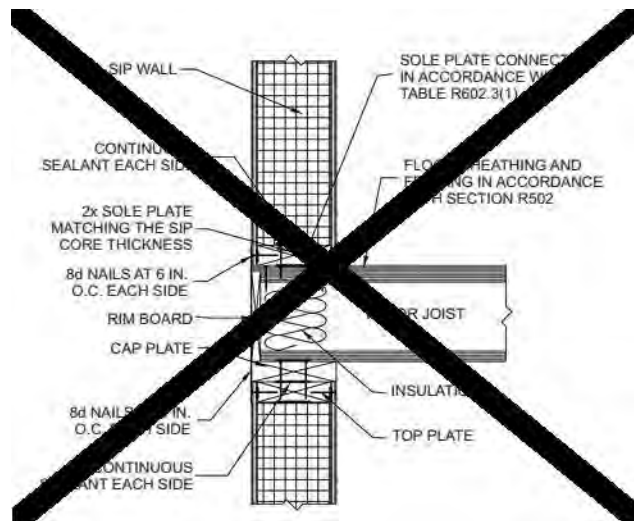


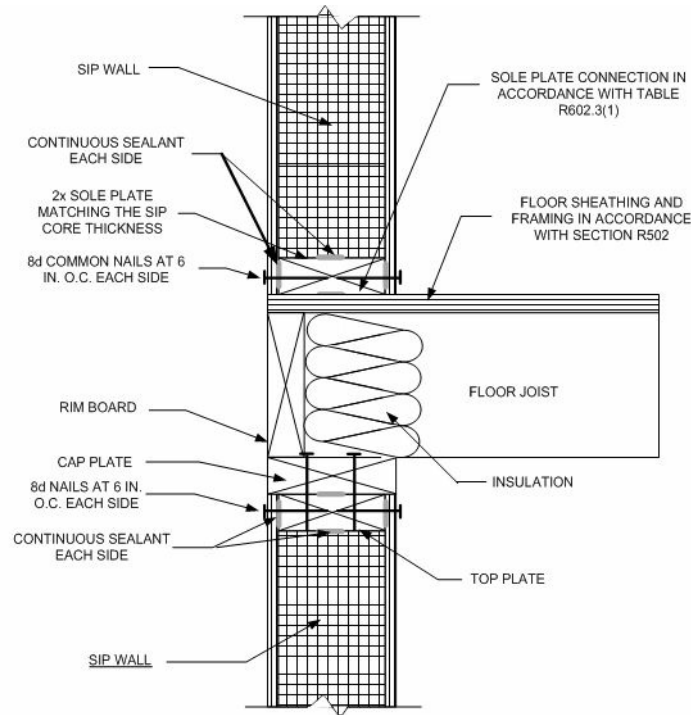


For SI: 1 inch = 25.4 mm.

Note: Figures illustrate SIP-specific attachment requirements. Other connections shall be made in accordance with Tables R602.3(1) and (2) as appropriate.

FIGURE R610.5 (4)
SIP WALL-TO-WALL PLATFORM FRAME CONNECTION

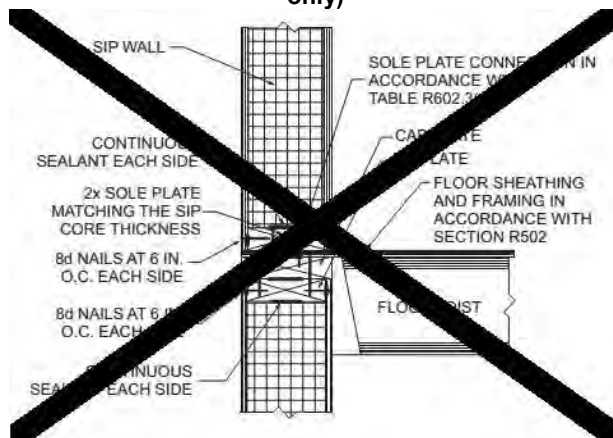




For SI: 1 inch = 25.4 mm.

Note: Figures illustrate SIP-specific attachment requirements. Other connections shall be made in accordance with Tables R602.3(1) and (2), as appropriate.

FIGURE R610.5 (5)
SIP WALL-TO-WALL BALLOON-HANGING FLOOR FRAME CONNECTION (I-Joist floor shown for illustration only)



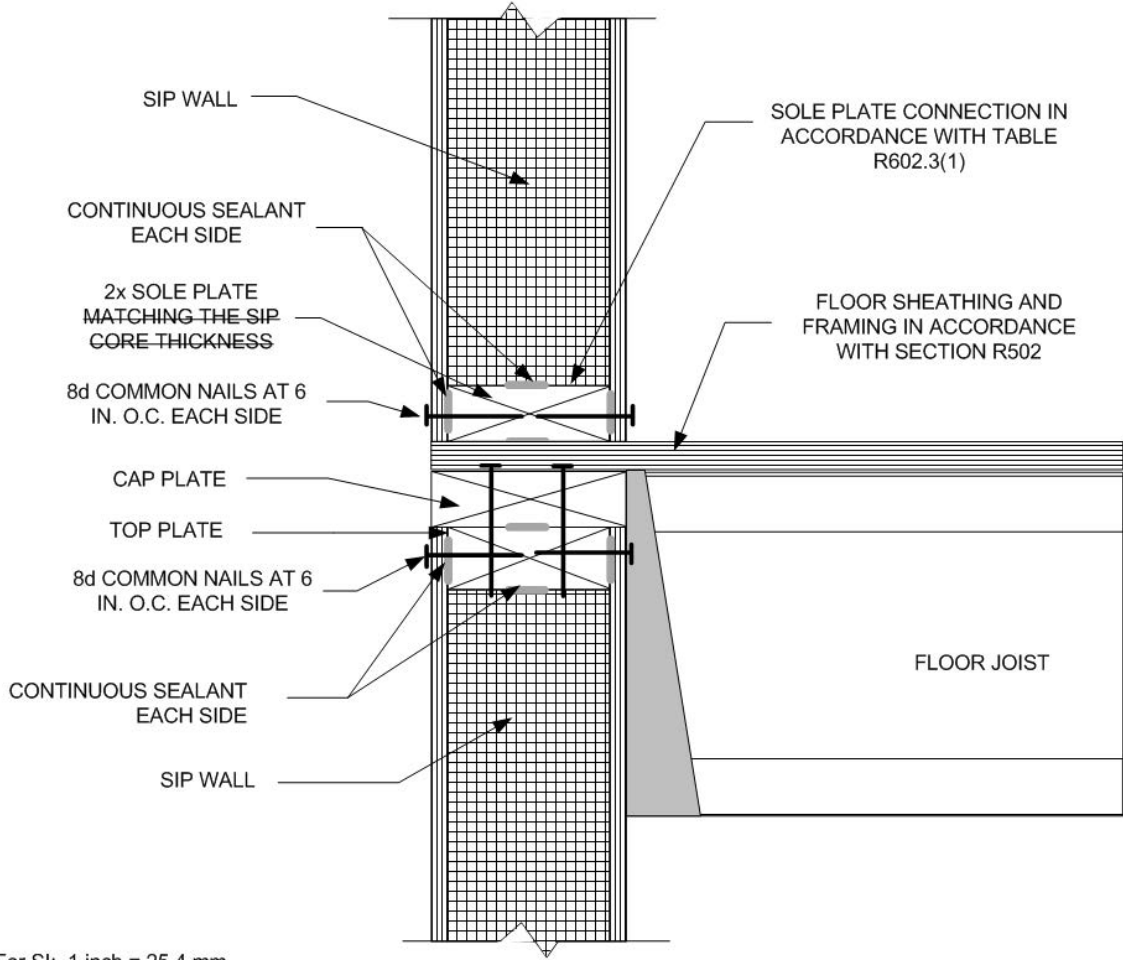
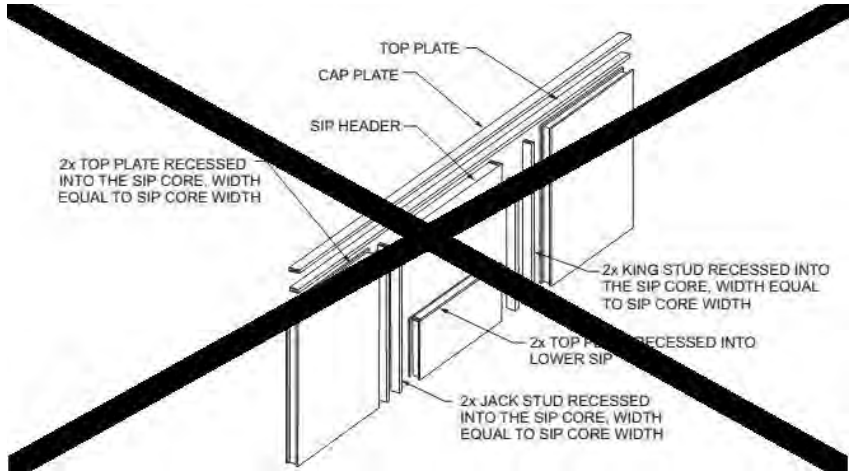
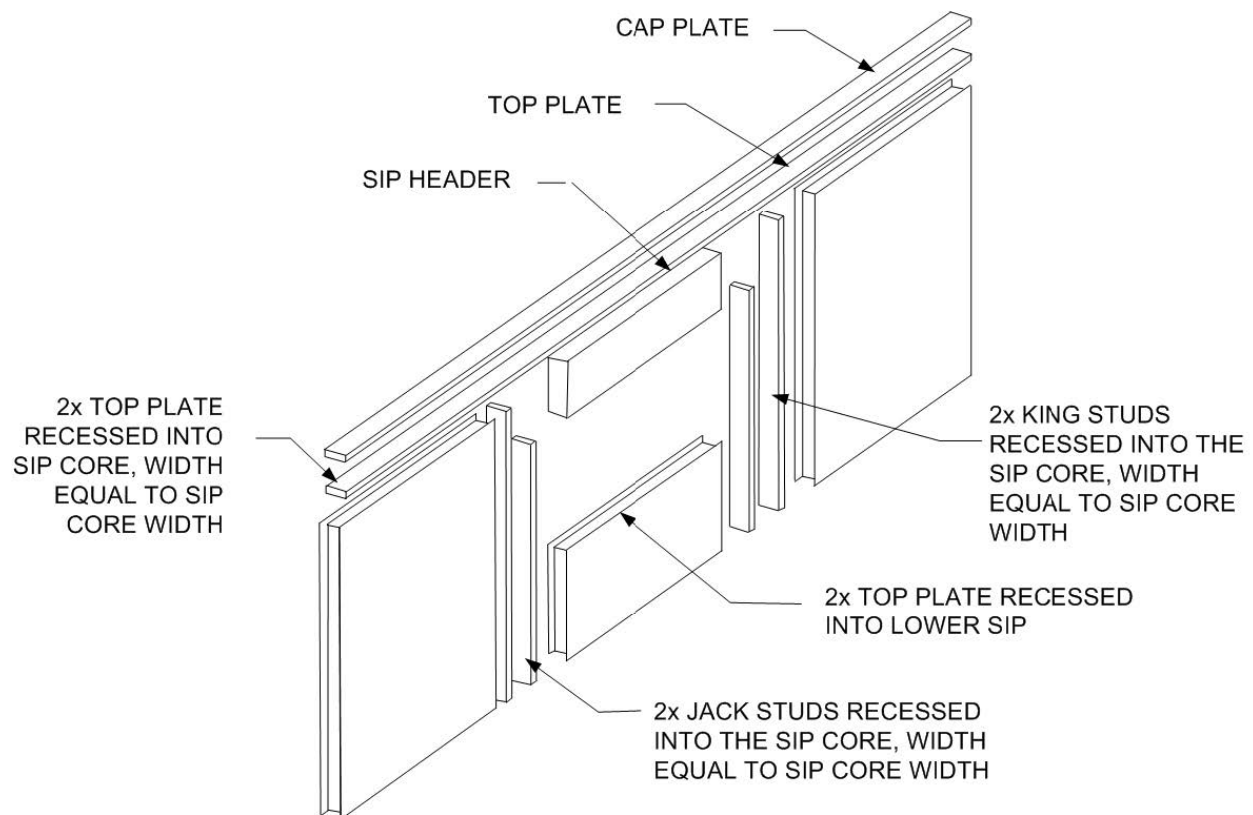


FIGURE R610.5.1 SIP WALL FRAMING CONFIGURATION





For SI: 1 inch = 25.4 mm.

Notes:

1. Top plates shall be continuous over header.
2. Lower 2x top plate shall have a width equal to the SIP core width and shall be recessed into the top edge of the panel. Cap plate shall be placed over the recessed top plate and shall have a width equal to the SIPs width.
3. SIP facing surfaces shall be nailed to framing and cripples with 8d common or galvanized box nails spaced 6 inches on center.
4. Galvanized nails shall be hot-dipped or tumbled. Framing shall be attached in accordance to Section R602.3(1) unless otherwise provide for in Section R610.

Add new text as follows:

R610.5.3 Panel to panel connection. SIPs shall be connected at vertical in-plane joints in accordance with Figure R610.8 or by other approved methods.

R610.5.4 Corner framing. Corner framing of SIP walls shall be constructed in accordance with Figure R610.9.

Revise as follows:

R610.5.3~~R610.5.5~~ Wall bracing. SIP walls shall be braced in accordance with Section R602.10. SIP walls shall be considered continuous wood structural panel sheathing (bracing Method CS-WSP) for purposes of computing required bracing. SIP walls shall meet the requirements of Section R602.10.4.2 except that SIP corners shall be fabricated as shown in Figure R610.9. Where SIP walls are used for wall bracing, the SIP bottom plate shall be attached to wood framing below in accordance with Table R602.3(1).

Add new text as follows:

R610.5.6 Thermal barrier. SIP walls shall be separated from the interior of a building by an approved thermal barrier in accordance with Section R316.4.

Delete without substitution:

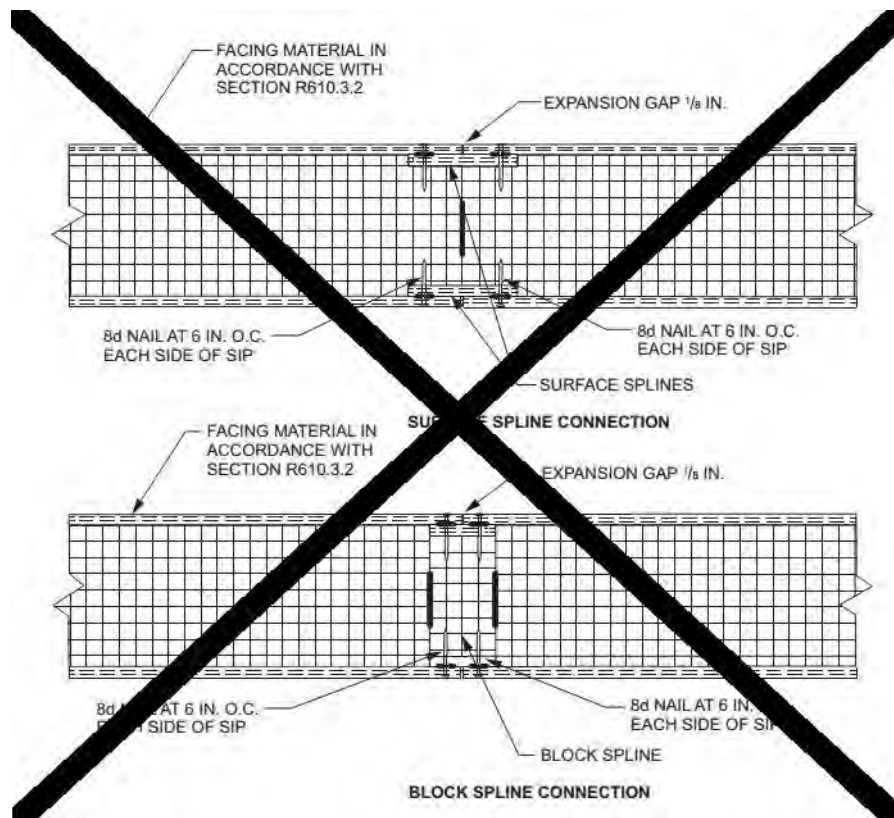
R610.8 Connection. SIPs shall be connected at vertical in-plane joints in accordance with Figure R610.8 or by other approved methods.

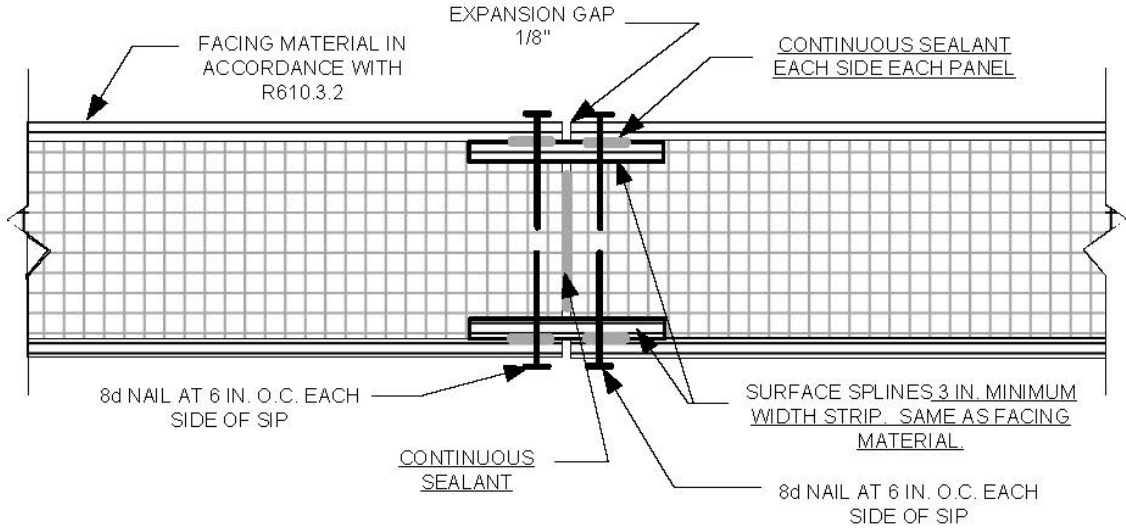
Revise as follows:

R610.10 R610.8 Headers. SIP headers shall be designed and constructed in accordance with Table R610.10 R610.8 and Figure R610.5.1. SIP headers shall be continuous sections without splines. Headers shall be not less than 11 7/8 inches (302 mm) deep. Headers longer than 4 feet (1219 mm) shall be constructed in accordance with Section R602.7. The strength axis of the facers on the header shall be oriented horizontally.

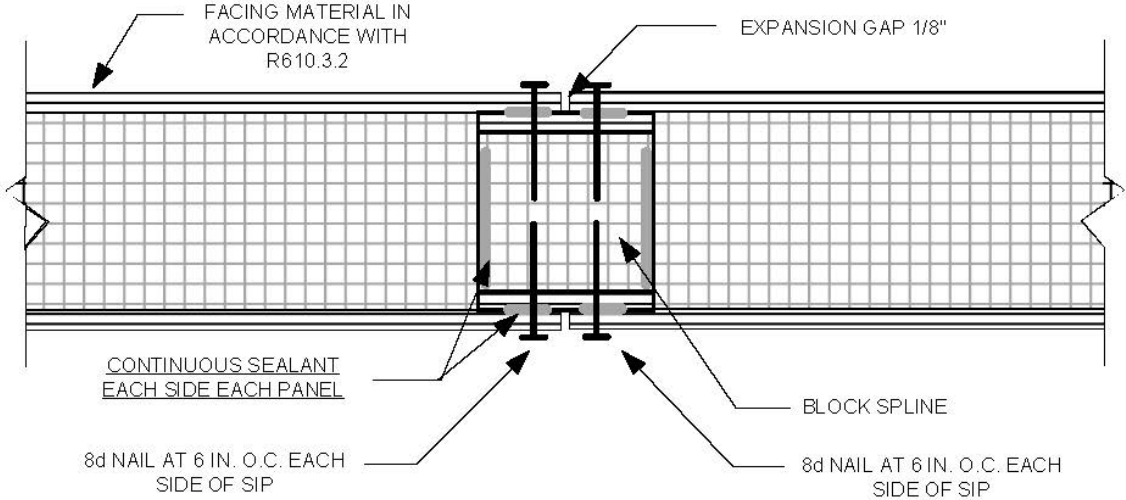
Delete and substitute as follows:

FIGURE R610.8
TYPICAL SIP WALL PANEL-TO-PANEL CONNECTION DETAILS FOR VERTICAL IN-PLANE JOINTS





SURFACE SPLINE CONNECTION



BLOCK SPLINE CONNECTION

For SI: 1 inch = 25.4 mm.

TABLE R610.10-R610.8
MAXIMUM SPANS FOR 11-⁷/₈-INCH-DEEP INCH OR DEEPER SIP HEADERS (feet)^a

LOAD CONDITION	SNOW LOAD (psf)	BUILDING width (feet)				
		24	28	32	36	40
Supporting roof only	20	4	4	4	4	2
	30	4	4	4	2	2
	50	2	2	2	2	2
	70	2	2	2	N/ADR	N/ADR
Supporting roof and one-story	20	2	2	N/ADR	N/ADR	N/ADR
	30	2	2	N/ADR	N/ADR	N/ADR
	50	2	N/ADR	N/ADR	N/ADR	N/ADR
	70	N/ADR	N/ADR	N/ADR	N/ADR	N/ADR

For SI: 1 inch = 25.4 mm, 1 foot = 304.8 mm, 1 pound per square foot = 0.0479 kPa.

N/A = Not Applicable.

a. Design assumptions:

Maximum deflection criterion: $L/360-240$. Maximum roof dead load: 10 psf.

Maximum ceiling load: 5 psf. Maximum ceiling live load: 20 psf.

Maximum second-floor live load: 30 psf. Maximum second-floor dead load: 10 psf.

Maximum second-floor dead load from walls: 10 psf

Maximum first floor dead load: 10 psf.

Wind loads based on Table R301.2(2).

Strength axis of facing material applied horizontally.

DR = Design Required

b. Building width is in the direction of horizontal framing members supported by the header.

c. The table provides for roof slopes between 3:12 and 12:12.

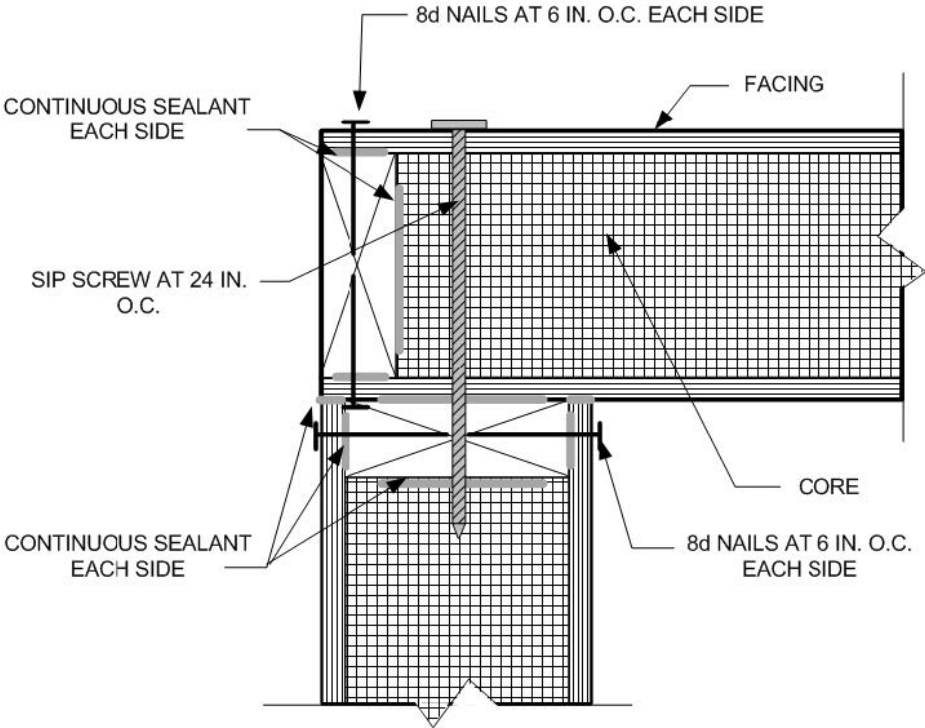
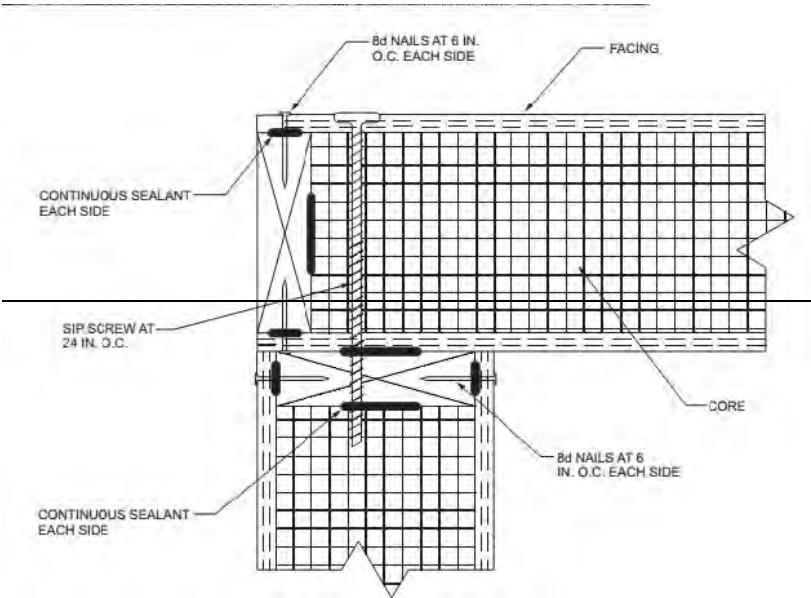
d. The maximum roof overhang is 24 inches (610 mm).

Delete without substitution:

~~**R610.9 Corner framing.** Corner framing of SIP walls shall be constructed in accordance with Figure R610.9.~~

Delete and substitute as follows:

**FIGURE R610.9
SIP CORNER FRAMING DETAIL**



For SI: 1 inch = 25.4 mm.

Delete without substitution:

R610.3.1 Core. The core material shall be composed of foam plastic insulation meeting one of the following requirements:

1. ASTM C 578 and have a minimum density of 0.90 pounds per cubic feet (14.4 kg/m³).
2. Polyurethane meeting the physical properties shown in Table R610.3.1.
3. An *approved* alternative.

All cores shall meet the requirements of Section R316.

Reference standards type: This reference standard is new to the ICC Code Books
Add new standard(s) as follows:

ANSI/APA PRS 610.1. Standard for Performance-Rated Structural Insulated Panels in Wall Applications.

Reason: The proposal is a minor reorganization and clarification of the Structural Insulated Panels (SIPs) section. The intention is to add clarity to the proposal as it is currently written. The original SIP language was based on the HUD document Prescriptive Method for Structural Insulated Panels (SIPs) Used in Wall Systems in Residential Construction. Since the inclusion of SIPs in the IRC, there have been several changes that have revised the SIP requirements. However, in some instances, the changes do not match the language used in other materials (wood, cold formed steel, etc.). Proposed changes are intended to bring the SIPs provisions more in line with the other sections of the IRC.

In addition, ANSI/APA PRS 610.1, Standard for Performance-Rated Structural Insulated Panels in Wall Applications, a consensus-based document is proposed for addition to the 2018 IRC. As a result, much of the detailed information currently in the IRC with respect to SIP core, facers and adhesive requirements may now be taken out of the IRC. (Free downloads of this new standard are available at <http://www.apawood.org/registrationpop?pubID=f0e25ef1-d7fe-42e0-9e08-0291b94efb04>)

To summarize the changes:

- Section R610.2 – added "square" to the snow load such that it reads "pounds per square foot". The SI conversion is correct as shown.
- Section R610.3.1 – Removes SIPs core details from the body of the code and references ANSI/APA PRS 610.1.
- Section R610.3.2 – Removes SIPs facer details from the body of the code and references ANSI/APA PRS 610.1.
- Section R610.3.3 – Removes SIPs adhesive details from the body of the code and references ANSI/APA PRS 610.1.
- New Section R610.3.4 - Adds thermal barrier requirements from the HUD document into Section R610. These requirements are in line with the requirements of IRC Section R316.4.
- Section R610.4.1 – The inspection and labeling requirements have been specified in ANSI/APA PRS 610.1, this section deleted.
- Sections R610.5.3 and R610.5.4 - Moved from current location in Section R610.8 and R610.9 respectively to proposed location. This puts all of the connection details in one place. No technical changes made.
- Section R610.5.5 – Renumbered wall bracing provisions to accommodate proposed new locations for R610.5.3 and R610.5.4. Also added reference to bracing method CS-WSP to clarify bracing equivalence.
- Section R610.8 – Renumbered section and referenced tables and sections. No technical changes. Added a requirement that the strong axis of the header facers shall be placed in a horizontal orientation.
- Table R610.8 – Renumbered table and added clarifying language and additional footnotes to simplify use of the table. Corrected deflection criteria in footnotes.
- Figure R610.5(1) – Added reference to bottom wall connection for clarity.
- Figure R610.5(2) – Added reference to bottom wall connection for clarity. Clarified foundation annotation and corrected "FIRST STORY" annotation.
- Figure R610.5(3) – Removed gusset plate and reference. Modified callout for roof framing to include trusses and conventional roof framing. Added roof sheathing callout. Added cap-plate-to-top-plate connection requirement. Made adjustments to arrow heads to more clearly identify referenced portion.
- Figure R610.5(4) – Added "SIP Wall" callout to first story wall, and added an additional "Continuous Sealant" arrow at upper wall. Made adjustments to arrow heads to more clearly identify referenced portion.
- Figure R610.5(5) – Some editorial changes were made to callouts, arrow heads repositioned slightly to better indicate referenced portions. Title of figure changed to more accurately reflect figure.
- Figure R610.5.1 – Footnote 4 was removed as it is a duplicate of the requirements in the text. "TOP PLATE" arrow moved to better identify recessed top plate.
- Figure R610.5.2 – Sealant added and referenced in new figure. Capillary break more clearly shown and anchor bolt requirement deleted and reference to Section R403.1.6 added.
- Figure R610.5.8 – Sealant was added to figure and a minimum splice plate size was provided. The figure title was changed to better describe figure and the term "connection" was removed from the figure sub-headings.
- Figure R610.5.9 – Additional arrows were added to the "Continuous Sealant" callout.

All figures have been redrawn and reformatted to provide a cleaner, more easily understood IRC.

Note that many of the changes requested above were placed before the committee last cycle. Some concerns about the minimum foam requirements were raised by the foam industry and subsequently the whole change was denied. The foam requirements as well as the material requirements for the wood structural panel and adhesive have all been included in the national consensus-based ANSI/APA PRS 610.1 standard. Just the editorial/clarification portions of the original proposal remain in this proposal.

We encourage the code body to accept this code change proposal providing requisite clarity.

Cost Impact: Will not increase the cost of construction

This proposal reorganizes the existing provisions, corrects typo errors in text and figures, and recognizes new consensus standards.

Public Hearing Results

Committee Action:

Approved as Modified

Modify as follows:

R610.3.1 Core. The core material shall be composed of foam plastic insulation meeting one of the following requirements:

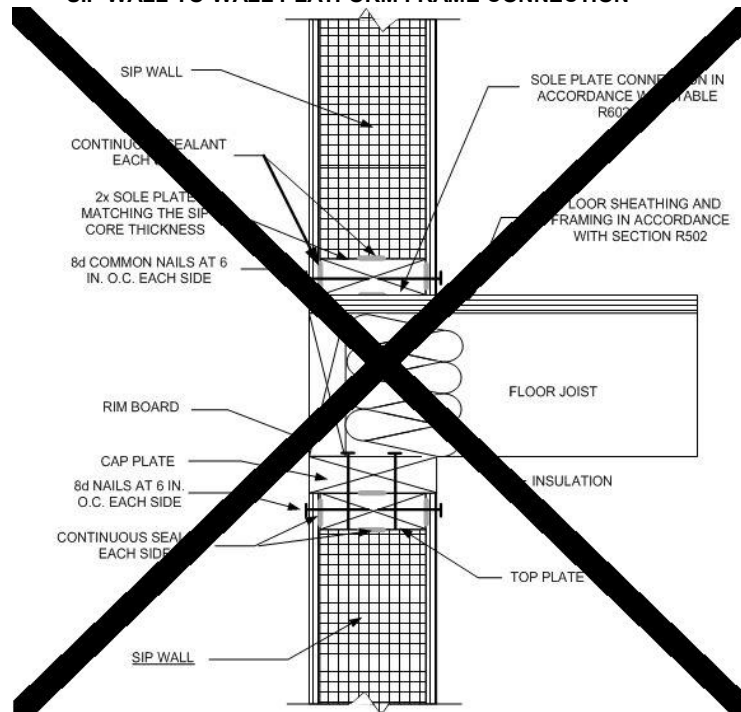
1. ASTM C 578 and have a minimum density of 0.90 pounds per cubic feet (14.4 kg/m³).
2. Polyurethane meeting the physical properties shown in Table R610.3.1.
3. An approved alternative.

All cores shall meet the requirements of Section R316.

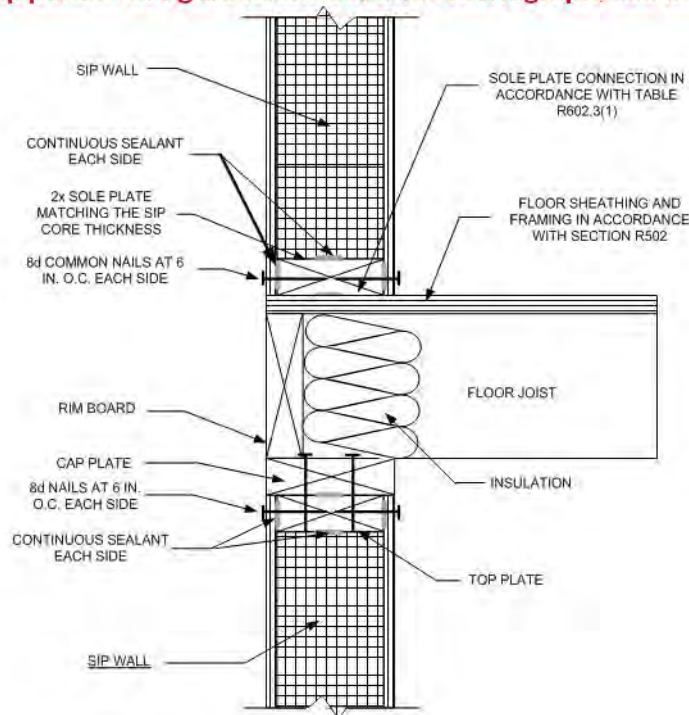
R610.5 Wall construction. Exterior walls of SIP construction shall be designed and constructed in accordance with the provisions of this section and Tables R610.5(1) and R610.5(2) and Figures R610.5(1) through R610.5(5). SIP walls shall be fastened to other wood building components in accordance with Tables R602.3(1) through R602.3(4).

Framing shall be attached in accordance with Table R602.3(1) unless otherwise provided for in Section R610.

**FIGURE R610.5 (4)
SIP WALL-TO-WALL PLATFORM FRAME CONNECTION**



(Top portion of figure below cut off in monograph, see below)



For SI: 1 inch = 25.4 mm.

Note : Figures illustrate SIP-specific attachment requirements. Other connections shall be made in accordance with Tables R602.3(1) and (2), as appropriate.

R610.5.1 Top plate connection. SIP walls shall be capped with a double top plate installed to provide overlapping at corner, intersections and splines in accordance with Figure R610.5.1. The double top plates shall be made up of a single 2 by top plate having a width equal to the width of the panel core, and shall be recessed into the SIP below. Over this top plate a cap plate shall be placed. The cap plate width shall match the SIP thickness and overlap the facers on both sides of the panel. End joints in top plates shall be offset not less than 24 inches (610 mm).

R610.5.2 Bottom (sole) plate connection. SIP walls shall have full bearing on a sole plate having a width equal to the nominal width of the foam core. Where SIP walls are supported directly on continuous foundations, the wall wood sill plate shall be anchored to the foundation in accordance with Figure R610.5.2 and Section R403.1.

R610.6 Interior load-bearing walls. Interior load-bearing walls shall be constructed as specified for exterior walls.

R610.7 Drilling and notching. The maximum vertical chase penetration in SIPs shall have a maximum side dimension of 2 inches (51 mm) centered in the panel. Vertical chases shall have a minimum spacing of 24 inches (610 mm) on center. A maximum of two horizontal chases shall be permitted in each wall panel—one at 14 inches (360 mm) plus or minus 2 inches (51 mm) from the bottom of the panel and one at 48 inches (1220 mm) plus or minus 2 inches (51 mm) from the bottom edge of the SIPs panel. Additional penetrations are permitted where justified by analysis.

R610.10.1 Wood structural panel box headers. Wood structural panel box headers shall be allowed where SIP headers are not applicable. Wood structural panel box headers shall be constructed in accordance with Figure R602.7.3 and Table R602.7.3.

Committee Reason: The committee approved the proposal based on the proponents published reason statement. The proposal adds a new standard and clarifies and cleans up several sections of the SIPS requirements. The modification corrects several errors that occurred during the proposal submittal process.

Assembly Action:

None

Report of Committee Action Hearings
--

Public Comment 1:

Edward Keith, representing APA- The Engineered Wood Association (ed.keith@apawood.org); Borjen Yeh (borjen.yeh@apawood.org) requests Approve as Modified by this Public Comment.

Further modify as follows:

R610.3 Materials. SIPs shall comply with the ~~following criteria:~~ requirements of ANSI/APA PRS 610.1.

Commenter's Reason: This Public Comment addresses Sections R610.3. Section R610.3 was inadvertently left out of the monograph. It references the new ANSI/APA standard for SIPs panels and is the justification for the removal of the core, facers, and adhesives tables from the code as these are covered in the standard. We are asking the code body to approve the editorial change R610.3 and ask for a vote of Approved as modified by the Public Comment.

Final Action Results

RB217-16**AMPC1**

[←BACK](#)

Code Change No: **S275-16 Part II**

Original Proposal

Section: R317.3.1, R317.3.3

Proponent: Edwin Huston, representing National Council of Structural Engineers' Associations (NCSEA) (huston@smithhustoninc.com)

THIS IS A 2 PART CODE CHANGE. PART I WILL BE HEARD BY THE IBC STRUCTURAL COMMITTEE. PART II WILL BE HEARD BY THE IRC-BUILDING COMMITTEE. SEE THE TENTATIVE HEARING ORDERS FOR THESE COMMITTEES.

Revise as follows:

R317.3.1 Fasteners for preservative-treated wood. Fasteners, including nuts and washers, for preservative-treated wood shall be of hot-dipped, zinc-coated galvanized steel, stainless steel, silicon bronze or copper. Staples shall be of stainless steel. Coating types and weights for connectors in contact with preservative-treated wood shall be in accordance with the connector manufacturer's recommendations. In the absence of manufacturer's recommendations, a minimum of ASTM A 653 type G185 zinc-coated galvanized steel, or equivalent, shall be used.

Exceptions:

1. one/two ($1/2$)-inch-diameter (12.7 mm) or greater steel bolts.
2. Fasteners other than nails, staples, and timber rivets shall be permitted to be of mechanically deposited zinc-coated steel with coating weights in accordance with ASTM B 695, Class 55 minimum.
3. Plain carbon steel fasteners in SBX/DOT and zinc borate preservative-treated wood in an interior, dry environment shall be permitted.

R317.3.3 Fasteners for fire-retardant-treated wood used in exterior applications or wet or damp locations. Fasteners, including nuts and washers, for fire-retardant-treated wood used in exterior applications or wet or damp locations shall be of hot-dipped, zinc-coated galvanized steel, stainless steel, silicon bronze or copper. Fasteners other than nails, staples, and timber rivets shall be permitted to be of mechanically deposited zinc-coated steel with coating weights in accordance with ASTM B 695, Class 55 minimum.

Reason: Over the past several code cycles staples have been included as another type of fastener used in various types of wood-to-wood connections. The intention of this proposal is to better integrate staples into the code so that the provisions for small diameter fasteners (nail and timber rivets) also are explicitly extended to staples where applicable. This repeatedly occurs in the limitations for fasteners in treated wood. The phrase "other than nails and timber rivets" is being rewritten to include staples as well. This occurs in both the IBC and IRC in sections: 2304.10.5.1, 2304.10.5.3, R317.3.1 and R317.3.3.

The second part of this proposal is to specifically limit staples to stainless steel where exposed to high corrosion environments. The thin wire gages used in staple fasteners (16ga – 14ga) are much thinner than those used in nails, and are consequentially more susceptible to corrosion. Also, according to ICC ESR-1539 report for power-drive staples and nails, currently stainless steel staples are the only available option for staples to meet the increased corrosion resistance requirements of sections 2304.10.5.1 and R317.3.1. By specifically specifying staples as requiring stainless steel this avoids confusion and possible misuse of other types of staples in increased corrosion risk applications.

Cost Impact: Will increase the cost of construction

Currently when staples are used in treated wood the only known available option is to use stainless steel staples. In this case there would be no cost increase in construction.

For use in treated wood if staples are not presently stainless then there would be a slight cost increase, however we do not feel that these staples would be code conforming. In this case any increase in performance would justify the additional cost

**Report of Committee Action
Hearings**

Committee Action:

Approved as Submitted

Committee Reason: This proposal is consistent with other practices used for treated materials.

Assembly Action

None

Final Action Results

S275-16 Part II

AS

[←BACK](#)

[←BACK](#)

Code Change No: **S300-16 Part II**

Original Proposal

Section: IRC: R702.3.1, R702.3.1.1 (New)

Proponent: Mike Fischer, representing The Center for the Polyurethanes Industry of the American Chemistry Council (mfischer@kellencompany.com)

THIS IS A 2 PART CODE CHANGE. PART I WILL BE HEARD BY THE IBC STRUCTURAL COMMITTEE. PART II WILL BE HEARD BY THE IRC-BUILDING & ENERGY COMMITTEE. SEE THE TENTATIVE HEARING ORDERS FOR THESE COMMITTEES.

Revise as follows:

R702.3.1 Materials. Gypsum board and gypsum panel product materials and accessories shall conform to ASTM C 22, C 475, C 514, C 1002, C 1047, C 1177, C 1178, C 1278, C 1396 or C 1658 and shall be installed in accordance with the provisions of this section. ~~Adhesives for the installation of gypsum board and gypsum panel products shall conform to ASTM C 557.~~

Add new text as follows:

R702.3.1.1 Adhesives Adhesives for the installation of gypsum board and gypsum panel products shall conform to ASTM C 557. All other adhesives for the installation of gypsum board and gypsum panel products shall conform to ASTM C557. Supports and fasteners used to attach gypsum board and gypsum panel products shall comply with Table R702.3.5 or other approved method.

Reference standards type: This reference standard is new to the ICC Code Books

Add new standard(s) as follows:

ASTM D 6464-03a(2009)e1 Standard Specification for Expandable Foam Adhesives for Fastening Gypsum Wallboard to Wood Framing

Reason: This proposal adds a new referenced standard, ASTM D 6464, which applies to expandable foam adhesives used with gypsum products. The code today refers only to ASTM C 557 for adhesives used with gypsum board, but not all adhesives are included in the scope of ASTM C 557. The new referenced standard applies only to expandable foam adhesives, which are currently qualified for use by product evaluation reports. Adding the mandatory scoping provision makes it clear that there will be two separate adhesive standards referenced, and that they apply to different types of products, and adds a mandatory statement outlining the requirements for adhesives used to attach gypsum board products.

Additionally, the proposal adds a pointer to Table R702.3.5 or requires approved fastening methods for gypsum products using adhesives. Table R702.3.5 includes important provisions for attachment methods with and without adhesives; the pointer calls attention to the need to consider proper fastening.

Cost Impact: Will not increase the cost of construction

The proposal increases product selection options, but contains no mandatory requirements.

Report of Committee Action Hearings

Committee Action:

Approved as Modified

Modify as follows:

R702.3.1.1 Adhesives ~~Adhesives-Expandable foam adhesives~~ for the installation of gypsum board and gypsum panel products shall conform to ASTM C ~~557~~6464. All other adhesives for the installation of gypsum board and gypsum panel products shall

[←BACK](#)

conform to ASTM C557. Supports and fasteners used to attach gypsum board and gypsum panel products shall comply with Table R702.3.5 or other approved method.

Committee Reason: The committee approved this proposal based on the proponents published reason statement. The modification corrects the reference standard number. With the modification this is a good code change that add a new standard for expandable foam adhesive.

Assembly Action:

None

Final Action Results

S300-16 Part II

AM

Code Change No: **RB202-16**

Original Proposal

Section: 507.3.5, R507, R507.2 (New), R507.2.1 (New), R507.2.1.1 (New), R507.2.3 (New), R507.2.4 (New), R507.2.5 (New), R507.3, R507.3.1, R507.3.2, R507.3.3, R507.3.4

Proponent: Charles Bajnai, representing Deck Code Coalition and Chesterfield County, VA; and North American Deck and Railing Association (NADRA) (bajnaic@chesterfield.gov)

Add new text:

**SECTION R507
EXTERIOR DECKS**

R507.2 Materials Materials used for the construction of decks shall comply with this section.

R507.2.1 Wood materials. All wood materials shall be No.2 grade or better lumber, preservative-treated in accordance with Section R317 or approved, naturally durable lumber, and termite protected where required in accordance with Section R318. Where design in accordance with Section R301 is provided, all wood structural members shall be designed using the wet service factor defined in AWC NDS. All cuts, notches, and drilled holes of preservative treated wood members shall be treated in accordance with Section R317.1.1. All preservative-treated wood products in contact with the ground shall be labeled for such usage.

R507.2.1.1 Engineered wood products. Engineered wood products shall be in accordance with Section R502.

Revise as follows:

~~R507.3~~ R507.2.2 Plastic composite deck boards, stair treads, guards, or handrails. Plastic composite exterior deck boards, stair treads, guards and handrails shall comply with the requirements of ASTM D 7032 and the requirements of Section 507.3.

~~R507.3.1~~ R507.2.2.1 Labeling. Plastic composite deck boards and stair treads, or their packaging, shall bear a label that indicates compliance to ASTM D 7032 and includes the allowable load and maximum allowable span determined in accordance with ASTM D 7032. Plastic or composite handrails and guards, or their packaging, shall bear a label that indicates compliance to ASTM D 7032 and includes the maximum allowable span determined in accordance with ASTM D 7032.

~~R507.3.2~~ R507.2.2.2 Flame spread index. Plastic composite deck boards, stair treads, guards, and handrails shall exhibit a flame spread index not exceeding 200 when tested in accordance with ASTM E 84 or UL 723 with the test specimen remaining in place during the test.

- **Exception:** Plastic composites determined to be noncombustible.

~~R507.3.3~~ R507.2.2.3 Decay resistance. Plastic composite deck boards, stair treads, guards and handrails containing wood, cellulosic or other biodegradable materials shall be decay resistant in accordance with ASTM D 7032.

~~R507.3.4~~ R507.2.2.4 Termite resistance. Where required by Section 318, plastic composite deck boards, stair treads, guards and handrails containing wood, cellulosic or other biodegradable materials shall be termite resistant in accordance with ASTM D 7032.

507.3.5 R507.2.2.5 Installation of plastic composites. Plastic composite deck boards, stair treads, guards and handrails shall be installed in accordance with this code and the manufacturer's instructions.

Add new text as follows:

R507.2.3 Fasteners and connectors. Metal fasteners and connectors used for all decks shall be in accordance with Section R317.3 and Table R507.2.3.

TABLE R507.2.3
FASTENER AND CONNECTOR SPECIFICATIONS FOR DECKS a,b

ITEM	MATERIAL	MINIMUM FINISH/COATING	ALTERNATE FINISH/COATING ^e
Nails and timber rivets	In accordance with ASTM F1667	Hot-dipped galvanized per ASTM A 153	Stainless steel; silicon bronze, or copper
Bolts ^c Lag screws ^d (including nuts and washers)	In accordance with ASTM A 307 (bolts), ASTM A 563 (nuts), ASTM F 844 (washers)	Hot-dipped galvanized per ASTM A153 Class C (Class D for 3/8" diameter and less) or Mechanically galvanized per ASTM B 695, Class 55 or 410 stainless steel	Stainless steel; silicon bronze, or copper
Metal connectors	Per manufacturer's specification	ASTM A 653 type G185 zinc coated galvanized steel or Post hot-dipped galvanized per ASTM A 123 providing a minimum average coating weight of 2.0 oz./ft ² (total both sides)	Stainless steel

NOTES

- Alternate materials, coatings and finishes shall be permitted.
- Fasteners and connectors exposed to salt water or located within 300 feet of a salt water shoreline shall be stainless steel.
- Holes for bolts shall be drilled a minimum 1/32" and a maximum 1/16" larger than the bolt.
- Lag screws 1/2" and larger shall be predrilled to avoid wood splitting per National Design Specification (NDS) for Wood Construction.
- Stainless steel driven fasteners shall be in accordance with ASTM F 1667.

R507.2.4 Flashing. Flashing shall be corrosion-resistant metal of minimum nominal 0.019 inch thickness or approved non-metallic material that is compatible with the substrate of the structure and the decking materials.

R507.2.5 Alternate materials. Alternate materials, including glass and metals shall be permitted.

Reason:

WHAT: This code change proposal provides design specifications for deck construction materials frequently found in deck construction.

WHY: The Deck Code Coalition (DCC) realized that the only materials specifically described in R507 was for plastic composite materials. They thought it was important to include design specifications for wood, fasteners and other materials. Footnote b reflects the requirement from FEMA Technical bulletin 8.



Alternative materials, including glass and metals, shall be permitted.



The Deck Code Coalition (DCC) is a diverse group of stakeholders, including building officials, industry associations, product manufacturers, design professionals, and academia who have worked since the 2012 IRC code development cycle in an effort to consolidate and improve deck construction methods from across the country.

Our goals are threefold:

1. Consolidate existing code scattered throughout the IRC under the newly expanded Section R507. Being able to easily locate all deck related code provisions in one section equally serves the builder, code official and design professional to a safer, code-conforming deck.
2. Create realistic, fact-based, prescriptive solutions to fill critical gaps in the current deck code. Many parts of existing deck code rely on subjective interpretations by the reader leading to an inconsistent approach to meeting minimum code.
3. Maintain and promote a safer deck structure without unduly burdening the builder. In all cases the DCC want to offer safe minimum requirements without stifling the creativity of the design professional or builder.

Cost Impact: Will not increase the cost of construction

There is no cost impact. These materials are already required by other sections of the IRC for connecting members outdoors.

Report of Committee Action Hearings

Committee Action:

Approved as Modified

Modify as follows:

TABLE R507.2.3 FASTENER AND CONNECTOR SPECIFICATIONS FOR DECKS ^{a,b}

NOTES

- a. Alternate-Equivalent materials, coatings and finishes shall be permitted.
- b. Fasteners and connectors exposed to salt water or located within 300 feet of a salt water shoreline shall be stainless steel.
- c. Holes for bolts shall be drilled a minimum 1/32" and a maximum 1/16" larger than the bolt.
- d. Lag screws 1/2" and larger shall be predrilled to avoid wood splitting per National Design Specification (NDS) for Wood Construction.
- e. Stainless steel driven fasteners shall be in accordance with ASTM F 1667.

Committee Reason: The committee approved this proposal based on the proponents published reason statement. This proposal allows options for materials and provides clear prescriptive requirements. The modification changes alternate to equivalent which is the more appropriate terminology.

Assembly Action

None

Final Action Results

RB202-16

AM

[←BACK](#)

Code Change No: **RB203-16**

Original Proposal

Section: R507, R507.2, R507.2.1, R507.2.2, R507.2.3, R507.2.4, R507.9.1 (New), R507.9.1.4 (New)

Proponent: Charles Bajnai, representing Deck Code Coalition and Chesterfield County, VA; and North American Deck and Railing Association (NADRA) (bajnaic@chesterfield.gov)

Revise as follows:

SECTION R507 EXTERIOR DECKS

~~**R507.2-R507.9 Deck ledger connection to Vertical and lateral supports at band joist.** Deck ledger connections to band joists~~

Vertical and lateral supports for decks shall be in accordance comply with this section, Tables R507.2 and R507.2.1, and Figures R507.2.1(1) and R507.2.1(2). For other grades, species, connection details and loading conditions, deck ledger connections shall be designed in accordance with Section R301.

R507.9.1 Vertical supports. Vertical loads shall be transferred to the band joists with ledgers in accordance with this section.

~~**R507.2.1-R507.9.1.1 Ledger details.** Deck ledgers installed in accordance with Section R507.2 shall be a minimum 2-inch by 8-inch (51 mm by 203 mm) nominal, pressure-preservative-treated southern pine, incised pressure-preservative-treated Hem-fir, or approved, naturally durable, No. 2 grade or better lumber. Deck ledgers installed in accordance with Section R507.2 shall not support concentrated loads from beams or girders. Deck ledgers shall not be supported on stone or masonry veneer.~~

~~**R507.2.2-R507.9.1.2 Band joist details.** Band joists attached by supporting a ledger in accordance with Section R507.2 shall be a minimum 2-inch-nominal (51 mm), solid-sawn, spruce-pine-fir or better lumber or a minimum 1-inch by 9' 1/2-inch (25 mm x 241 mm) dimensional, Douglas fir or better lumber, laminated veneer lumber. Band joists attached by a ledger in accordance with Section R507.2 shall be bear fully supported by a wall or sill plate below on the primary structure capable of supporting all required loads.~~

~~**R507.2.3-R507.9.1.3 Ledger to band joist fastener details.** Fasteners used in deck ledger connections in accordance with Table R507.2-R507.9.1.3(1) shall be hot-dipped galvanized or stainless steel and shall be installed in accordance with Table R507.2.1-R507.9.1.3(2) and Figures R507.2.1(1)-R507.9.1.3(1) and R507.2.1(2)-R507.9.1.3(2).~~

R507.9.1.4 Alternate ledger details. Alternate framing configurations supporting a ledger constructed to meet the load requirements of Section R301.5 shall be permitted.

~~TABLE R507.2-R507.9.1.3(1)~~

DECK LEDGER CONNECTION TO BAND JOIST^{a, b} (Deck live load = 40 psf, deck dead load = 10 psf, snow load ≤ 40 psf)

(Portions of table not shown remain unchanged)

For SI: 1 inch = 25.4 mm, 1 foot = 304.8 mm, 1 pound per square foot = 0.0479 kPa.

- a. Ledgers shall be flashed in accordance with Section R703.4 to prevent water from contacting the house band joist.
- b. Snow load shall not be assumed to act concurrently with live load.
- c. The tip of the lag screw shall fully extend beyond the inside face of the band joist.
- d. Sheathing shall be wood structural panel or solid sawn lumber.
- e. Sheathing shall be permitted to be wood structural panel, gypsum board, fiberboard, lumber or foam sheathing. Up to 1/2 -inch

thickness of stacked washers shall be permitted to substitute for up to $1/2$ inch of allowable sheathing thickness where combined with wood structural panel or lumber sheathing.

**TABLE ~~R507.2.4~~-~~R507.9.1.3~~(2)
PLACEMENT OF LAG SCREWS AND BOLTS IN DECK LEDGERS AND BAND JOISTS-**

(Portions of table not shown remain unchanged)

For SI: 1 inch = 25.4 mm.

- a. Lag screws or bolts shall be staggered from the top to the bottom along the horizontal run of the deck ledger in accordance with Figure R507.2.1(1).
- b. Maximum 5 inches.
- c. For engineered rim joists, the manufacturer's recommendations shall govern.
- d. The minimum distance from bottom row of lag screws or bolts to the top edge of the ledger shall be in accordance with Figure R507.2.1(1).

~~R507.2.4~~-~~R507.9.2~~ Deck lateral load-Lateral connection. The lateral load connection required by Section ~~R507.4~~. Lateral loads shall be permitted transferred to be in accordance with Figure ~~R507.2.3~~(1)the ground or ~~R507.2.3~~(2) to a structure capable of transmitting them to the ground.

Where the lateral load connection is provided in accordance with Figure ~~R507.2.3~~(1)~~R507.9.2~~(1), hold-down tension devices shall be installed in not less than two locations per deck, within 24 inches of each end of the deck. Each device shall have an allowable stress design capacity of not less than 1,500 pounds (6672 N).

Where the lateral load connections are provided in accordance with Figure ~~R507.2.3~~(2)~~R507.9.2~~(2), the hold-down tension devices shall be installed in not less than four locations per deck, and each device shall have an allowable stress design capacity of not less than 750 pounds (3336 N).

**FIGURE ~~R507.2.1~~(4)-~~R507.9.1.3~~(1)
PLACEMENT OF LAG SCREWS AND BOLTS IN LEDGERS**

(Portions of figure not shown remain unchanged)

For SI: 1 inch = 25.4 mm.

For SI: 1 inch = 25.4 mm.

**FIGURE ~~R507.2.1~~(2)-~~R507.9.1.3~~(2)
PLACEMENT OF LAG SCREWS AND BOLTS IN BAND JOISTS**

(Portions of figure not shown remain unchanged)

**FIGURE ~~R507.2.3~~(1)-~~R507.9.2~~(1)
DECK ATTACHMENT FOR LATERAL LOADS**

(Portions of figure not shown remain unchanged)

For SI: 1 inch = 25.4 mm.

For SI: 1 inch = 25.4 mm, 1 foot = 304.8 mm.

**FIGURE ~~R507.2.3~~(2)-~~R507.9.2~~(2)
DECK ATTACHMENT FOR LATERAL LOADS**

(Portions of figure not shown remain unchanged)

Reason:

WHAT: This code change moves the deck ledger attachment and lateral resistance details from Section R507. 2 to the end of the section.

WHY: The Deck Code Coalition (DCC) thought that the organization of the section would make more sense if it followed the same logical organization as the IRC in whole, namely from the ground up. We moved the ledger attachment details to the end of the section similar to the way wall bracing in R602.10 has supports at the end of the section.

The Deck Code Coalition (DCC) is a diverse group of stakeholders, including building officials, industry associations, product manufacturers, design professionals, and academia who have worked since the 2012 IRC code development cycle in an effort to consolidate and improve deck construction methods from across the country.

Our goals are threefold:

1. Consolidate existing code scattered throughout the IRC under the newly expanded Section R507. Being able to easily locate all deck related code provisions in one section equally serves the builder, code official and design professional to a safer, code-conforming deck.

2. Create realistic, fact-based, prescriptive solutions to fill critical gaps in the current deck code. Many parts of existing deck code rely on subjective interpretations by the reader leading to an inconsistent approach to meeting minimum code.

Maintain and promote a safer deck structure without unduly burdening the builder. In all cases the DCC want to offer safe minimum requirements

Cost Impact: Will not increase the cost of construction

There is no cost impact. This is a non-technical code change - it only moved the requirements from R507.2 to the end of the section.

**Report of Committee Action
Hearings**

Committee Action:

Approved as Submitted

Committee Reason: The committee approved this proposal based on the proponents published reason statement.

Assembly Action:

None

Final Action Results

RB203-16

AS

[←BACK](#)

Code Change No: **RB205-16**

Original Proposal

Section: R507, R507.3 (New), R507.3.1 (New), R507.3.2 (New)

Proponent: Charles Bajnai, representing Deck Code Coalition and Chesterfield County, VA; and North American Deck and Railing Association (NADRA) (bajnaic@chesterfield.gov)

Add new text:

R507.3 Footings. Decks shall be supported on concrete footings or other approved structural systems designed to accommodate all loads according to Section R301.

R507.3.1 Minimum size. The minimum size of concrete footings shall be in based on the tributary area and allowable soil bearing pressure in accordance with Table R401.4.1.

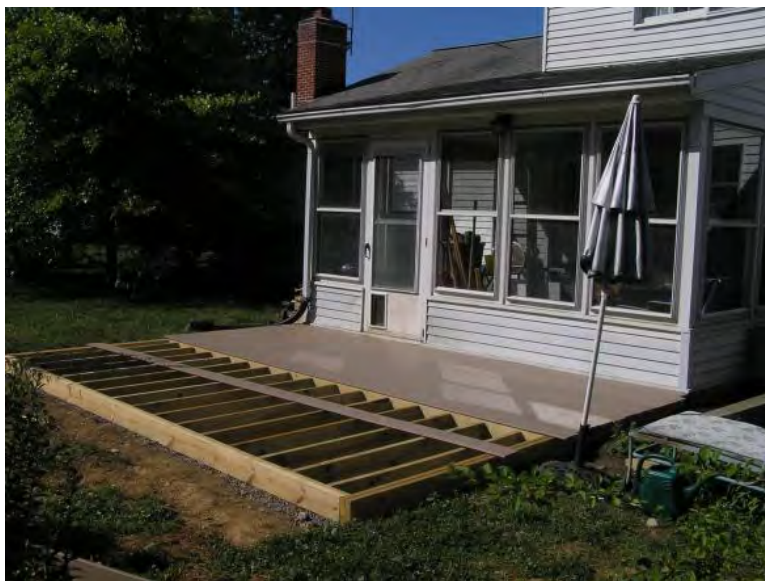
R507.3.2 Minimum depth. Deck footings shall extend below the frost line specified in Table R301.2(1) in accordance with Section R403.1.4.1.

Exception: Freestanding decks consisting of joists directly supported on grade over their entire length

Reason:

WHAT: This code change provides an exception for "freestanding wood patios" from having to comply with the requirement in R403 footings below frost line. It will allow a freestanding deck to be totally supported on the ground without any footings.

WHY: The Deck Code Coalition (DCC) did not foresee any safety concerns and thought it was reasonable to add language to affirm that freestanding wood patios do not need to have footings below the frost line. The code change complies with the requirement of R403.1.4.1, Exception #3: "Decks not supported by a dwelling need not be provided with footings that extend below the frost line."



The Deck Code Coalition (DCC) is a diverse group of stakeholders, including building officials, industry associations, product manufacturers, design professionals, and academia who have worked since the 2012 IRC code development cycle in an effort to consolidate and improve deck construction methods from across the country.

Our goals are threefold:

1. Consolidate existing code scattered throughout the IRC under the newly expanded Section R507. Being able to easily locate all deck related code provisions in one section equally serves the builder, code official and design professional to a safer, code-conforming deck.
2. Create realistic, fact-based, prescriptive solutions to fill critical gaps in the current deck code. Many parts of existing deck code rely on subjective interpretations by the reader leading to an inconsistent approach to meeting minimum code.
3. Maintain and promote a safer deck structure without unduly burdening the builder. In all cases the DCC want to offer safe minimum requirements without stifling the creativity of the design professional or builder.

Cost Impact: Will not increase the cost of construction

There is no cost impact. The code already provides an exception for footings below the frost line in Section R403.1.4.1 for freestanding decks.

Report of Committee Action Hearings
--

Committee Action:

Approved as Modified

Modify as follows:

R507.3 Footings. Decks shall be supported on concrete footings or other approved structural systems designed to accommodate all loads according to Section R301.

Exception: Freestanding decks consisting of joists directly supported on grade over their entire length.

R507.3.2 Minimum depth. Deck footings shall extend below the frost line specified in Table R301.2(1) in accordance with Section R403.1.4.1.

Exception: ~~Freestanding decks consisting of joists directly supported on grade over their entire length~~

Committee Reason: The committee approved this proposal based on the proponents published reason statement. This change provides allowance for footing size for decks. The modification moves the exception to the proper section.

Assembly Action

None

Final Action Results

RB205-16

AM

Code Change No: **RB206-16**

Original Proposal

Section: R507, R507.3 (New), R507.3.1 (New), R507.3.2 (New)

Proponent: Charles Bajnai, representing Deck Code Coalition and Chesterfield County, VA; and North American Deck and Railing Association (NADRA) (bajnaic@chesterfield.gov)

Add new text as follows:

R507.3 Footings Decks shall be supported on concrete footings or other approved structural systems designed to accommodate all loads according to Section R301.

R507.3.1 Minimum size. R507.3.1 Minimum size. The minimum size of concrete footings shall be based on the tributary area and allowable soil bearing pressure in accordance with Table R401.4.1.

R507.3.2 Minimum depth. Deck footings shall extend below the frost line specified in Table R301.2(1) in accordance with Section R403.1.4.1.

Exceptions:

Freestanding decks that meet all of the following criteria:

- a. The joists bear directly on precast concrete pier blocks at grade without support by beams or posts.
- b. The area of the deck does not exceed 200 square feet (18.9 m²).
- c. The walking surface is not more than 20 inches (616 mm) above grade at any point within 36 inches (914 mm) measured horizontally from the edge.

Reason:

WHAT: This code change provides the specifications for when a freestanding deck can be constructed on precast concrete pier blocks at grade.

WHY: The Deck Code Coalition (DCC) thought it was reasonable to add language to affirm that freestanding decks constructed on precast concrete pier blocks should be allowed. These types of blocks are popular because they are low cost, easy to use and readily available at home improvement stores around the country. The committee did not foresee any safety concerns based on the limitations specified.





The Deck Code Coalition (DCC) is a diverse group of stakeholders, including building officials, industry associations, product manufacturers, design professionals, and academia who have worked since the 2012 IRC code development cycle in an effort to consolidate and improve deck construction methods from across the country.

Our goals are threefold:

1. Consolidate existing code scattered throughout the IRC under the newly expanded Section R507. Being able to easily locate all deck related code provisions in one section equally serves the builder, code official and design professional to a safer, code-conforming deck.
2. Create realistic, fact-based, prescriptive solutions to fill critical gaps in the current deck code. Many parts of existing deck code rely on subjective interpretations by the reader leading to an inconsistent approach to meeting minimum code.
3. Maintain and promote a safer deck structure without unduly burdening the builder. In all cases the DCC want to offer safe minimum requirements without stifling the creativity of the design professional or builder.

Cost Impact: Will not increase the cost of construction

There is no cost impact. The builder was always required to provide deck footings in accordance with Section 4. In fact it might actually reduce the cost by giving prescriptive acceptance for footings on concrete pier blocks.

Report of Committee Action Hearings

Committee Action:

Approved as Submitted

Committee Reason: The committee approved this proposal based on the proponents published reason statement.

Assembly Action:

None

Final Action Results

RB206-16

AS

Code Change No: RB207-16

Original Proposal

Section: R507, R507.3 (New), R507.3.1 (New), R507.3.2 (New), TABLE R507.3.1 (New)

Proponent: Charles Bajnai, representing Deck Code Coalition and Chesterfield County, VA; and North American Deck and Railing Association (NADRA) (bajnaic@chesterfield.gov)

Add new text as follows:

R507.3 Footings. Decks shall be supported on concrete footings or other approved structural systems designed to accommodate all loads according to Section R301.

R507.3.1 Minimum size. The minimum size of concrete footings shall be in accordance with Table R507.3.1, based on the tributary area and allowable soil bearing pressure in accordance with Table R401.4.1.

R507.3.2 Minimum depth. Deck footings shall extend below the frost line specified in Table R301.2(1) in accordance with Section R403.1.4.1.

**TABLE TABLE R507.3.1
MINIMUM FOOTING SIZE FOR DECKS**

MINIMUM FOOTING SIZE FOR DECKS ^{a,c,d} (sqft)													
LIVE OR GROUND SNOW LOAD ^b (psf)	TRIBUTARY AREA (sqft)	1500			2000			2500			≥3000		
		Side of a square footing (in)	Diameter of a round footing (in)	Thickness (in)	Side of a square footing (in)	Diameter of a round footing (in)	Thickness (in)	Side of a square footing (in)	Diameter of a round footing (in)	Thickness (in)	Side of a square footing (in)	Diameter of a round footing (in)	Thickness (in)
40	20	12	14	6	12	14	6	12	14	6	12	14	6
	40	14	16	6	12	14	6	12	14	6	12	14	6
	60	17	19	6	15	17	6	13	15	6	12	14	6
	80	20	22	7	17	19	6	15	17	6	14	16	6
	100	22	25	8	19	21	6	17	19	6	15	17	6

	<u>120</u>	<u>24</u>	<u>27</u>	<u>9</u>	<u>21</u>	<u>23</u>	<u>7</u>	<u>19</u>	<u>21</u>	<u>6</u>	<u>17</u>	<u>19</u>	<u>6</u>
	<u>140</u>	<u>26</u>	<u>29</u>	<u>10</u>	<u>22</u>	<u>25</u>	<u>8</u>	<u>20</u>	<u>23</u>	<u>7</u>	<u>18</u>	<u>21</u>	<u>6</u>
	<u>160</u>	<u>28</u>	<u>31</u>	<u>11</u>	<u>24</u>	<u>27</u>	<u>9</u>	<u>21</u>	<u>24</u>	<u>8</u>	<u>20</u>	<u>22</u>	<u>7</u>
50	<u>20</u>	<u>12</u>	<u>14</u>	<u>6</u>	<u>12</u>	<u>14</u>	<u>6</u>	<u>12</u>	<u>14</u>	<u>6</u>	<u>12</u>	<u>14</u>	<u>6</u>
	<u>40</u>	<u>15</u>	<u>17</u>	<u>6</u>	<u>13</u>	<u>15</u>	<u>6</u>	<u>12</u>	<u>14</u>	<u>6</u>	<u>12</u>	<u>14</u>	<u>6</u>
	<u>60</u>	<u>19</u>	<u>21</u>	<u>6</u>	<u>16</u>	<u>18</u>	<u>6</u>	<u>14</u>	<u>16</u>	<u>6</u>	<u>13</u>	<u>15</u>	<u>6</u>
	<u>80</u>	<u>21</u>	<u>24</u>	<u>8</u>	<u>19</u>	<u>21</u>	<u>6</u>	<u>17</u>	<u>19</u>	<u>6</u>	<u>15</u>	<u>17</u>	<u>6</u>
	<u>100</u>	<u>24</u>	<u>27</u>	<u>9</u>	<u>21</u>	<u>23</u>	<u>7</u>	<u>19</u>	<u>21</u>	<u>6</u>	<u>17</u>	<u>19</u>	<u>6</u>
	<u>120</u>	<u>26</u>	<u>30</u>	<u>10</u>	<u>23</u>	<u>26</u>	<u>8</u>	<u>20</u>	<u>23</u>	<u>7</u>	<u>19</u>	<u>21</u>	<u>6</u>
	<u>140</u>	<u>28</u>	<u>32</u>	<u>11</u>	<u>25</u>	<u>28</u>	<u>9</u>	<u>22</u>	<u>25</u>	<u>8</u>	<u>20</u>	<u>23</u>	<u>7</u>
	<u>160</u>	<u>30</u>	<u>34</u>	<u>12</u>	<u>26</u>	<u>30</u>	<u>10</u>	<u>24</u>	<u>27</u>	<u>9</u>	<u>21</u>	<u>24</u>	<u>8</u>
	60	<u>20</u>	<u>12</u>	<u>14</u>	<u>6</u>	<u>12</u>	<u>14</u>	<u>6</u>	<u>12</u>	<u>14</u>	<u>6</u>	<u>12</u>	<u>14</u>
<u>40</u>		<u>16</u>	<u>19</u>	<u>6</u>	<u>14</u>	<u>16</u>	<u>6</u>	<u>13</u>	<u>14</u>	<u>6</u>	<u>12</u>	<u>14</u>	<u>6</u>
<u>60</u>		<u>20</u>	<u>23</u>	<u>7</u>	<u>17</u>	<u>20</u>	<u>6</u>	<u>16</u>	<u>18</u>	<u>6</u>	<u>14</u>	<u>16</u>	<u>6</u>
<u>80</u>		<u>23</u>	<u>26</u>	<u>9</u>	<u>20</u>	<u>23</u>	<u>7</u>	<u>18</u>	<u>20</u>	<u>6</u>	<u>16</u>	<u>19</u>	<u>6</u>
<u>100</u>		<u>26</u>	<u>29</u>	<u>10</u>	<u>22</u>	<u>25</u>	<u>8</u>	<u>20</u>	<u>23</u>	<u>7</u>	<u>18</u>	<u>21</u>	<u>6</u>
<u>120</u>		<u>28</u>	<u>32</u>	<u>11</u>	<u>25</u>	<u>28</u>	<u>9</u>	<u>22</u>	<u>25</u>	<u>8</u>	<u>20</u>	<u>23</u>	<u>7</u>
<u>140</u>		<u>31</u>	<u>35</u>	<u>12</u>	<u>27</u>	<u>30</u>	<u>10</u>	<u>24</u>	<u>27</u>	<u>9</u>	<u>22</u>	<u>24</u>	<u>8</u>
<u>160</u>		<u>33</u>	<u>37</u>	<u>13</u>	<u>28</u>	<u>32</u>	<u>11</u>	<u>25</u>	<u>29</u>	<u>10</u>	<u>23</u>	<u>26</u>	<u>9</u>
70	<u>20</u>	<u>12</u>	<u>14</u>	<u>6</u>	<u>12</u>	<u>14</u>	<u>6</u>	<u>12</u>	<u>14</u>	<u>6</u>	<u>12</u>	<u>14</u>	<u>6</u>
	<u>40</u>	<u>18</u>	<u>20</u>	<u>6</u>	<u>15</u>	<u>17</u>	<u>6</u>	<u>14</u>	<u>15</u>	<u>6</u>	<u>12</u>	<u>14</u>	<u>6</u>
	<u>60</u>	<u>21</u>	<u>24</u>	<u>8</u>	<u>19</u>	<u>21</u>	<u>6</u>	<u>17</u>	<u>19</u>	<u>6</u>	<u>15</u>	<u>17</u>	<u>6</u>
	<u>80</u>	<u>25</u>	<u>28</u>	<u>9</u>	<u>21</u>	<u>24</u>	<u>8</u>	<u>19</u>	<u>22</u>	<u>7</u>	<u>18</u>	<u>20</u>	<u>6</u>
	<u>100</u>	<u>28</u>	<u>31</u>	<u>11</u>	<u>24</u>	<u>27</u>	<u>9</u>	<u>21</u>	<u>24</u>	<u>8</u>	<u>20</u>	<u>22</u>	<u>7</u>
	<u>120</u>	<u>30</u>	<u>34</u>	<u>12</u>	<u>26</u>	<u>30</u>	<u>10</u>	<u>24</u>	<u>27</u>	<u>9</u>	<u>21</u>	<u>24</u>	<u>8</u>
	<u>140</u>	<u>33</u>	<u>37</u>	<u>13</u>	<u>28</u>	<u>32</u>	<u>11</u>	<u>25</u>	<u>29</u>	<u>10</u>	<u>23</u>	<u>26</u>	<u>9</u>
	<u>160</u>	<u>35</u>	<u>40</u>	<u>15</u>	<u>30</u>	<u>34</u>	<u>12</u>	<u>27</u>	<u>31</u>	<u>11</u>	<u>25</u>	<u>28</u>	<u>9</u>

- a. Interpolation permitted, extrapolation not permitted
- b. Based on highest load case: Dead + Live or Dead + Snow
- c. Assumes minimum square footing to be 12" x 12" x 6" for 6x6 post.
- d. If the support is a brick or cmu pier, the footing shall have a minimum 2" projection on all sides.
- e. Area, in square feet, of deck surface supported by post and footing.

Reason:

WHAT: This code change provides prescriptive language and a table for determining the minimum size and depth of deck footings based on tributary area, live load and soil bearing pressure. It provides the size based on either square or cylindrical footings.

WHY: The current code does not address footing size and depth. The information has to be gleaned out of Chapters 3 and 4. The Deck Code Coalition (DCC) thought a prescriptive table would be easier for deck builders – especially for homeowners who would not know how to calculate the size based on live load and soil's load bearing pressure.

Example:

Based on a typical 12'x 12" deck with two posts away from the house and a 40 psf live/snow load,

and 2000 psf soil bearing pressure:

Tributary area = $(1/4) \times 12' \times 12' = 36 \text{ sqft. @ } 2000 \text{ psf}$

Table says footing to be 12" x 12" x 6" (square) or 14" diameter (cylinder)



The Deck Code Coalition (DCC) is a diverse group of stakeholders, including building officials, industry associations, product manufacturers, design professionals, and academia who have worked since the 2012 IRC code development cycle in an effort to consolidate and improve deck construction methods from across the country.

Our goals are threefold:

1. Consolidate existing code scattered throughout the IRC under the newly expanded Section R507. Being able to easily locate all deck related code provisions in one section equally serves the builder, code official and design professional to a safer, code-conforming deck.
2. Create realistic, fact-based, prescriptive solutions to fill critical gaps in the current deck code. Many parts of existing deck code rely on subjective interpretations by the reader leading to an inconsistent approach to meeting minimum code.
3. Maintain and promote a safer deck structure without unduly burdening the builder. In all cases the DCC want to offer safe minimum requirements without stifling the creativity of the design professional builder.

MINIMUM FOOTING SIZE for DECKS * * * (sqft)													
LIVE or GROUND SNOW LOAD * (psf)	TRIBUTARY AREA * (sqft)	SOIL BEARING CAPACITY (psf)											
		1500			2000			2500			>3000		
		side of a square footing (in)	diameter of a round footing (in)	thickness (in)	side of a square footing (in)	diameter of a round footing (in)	thickness (in)	side of a square footing (in)	diameter of a round footing (in)	thickness (in)	side of a square footing (in)	diameter of a round footing (in)	thickness (in)
40	20	12	14	6	12	14	6	12	14	6	12	14	6
	40	14	16	6	12	14	6	12	14	6	12	14	6
	60	17	19	6	15	17	6	13	15	6	12	14	6
	80	20	22	7	17	19	6	15	17	6	14	16	6
	100	22	25	8	19	21	6	17	19	6	15	17	6
	120	24	27	9	21	23	7	19	21	6	17	19	6
	140	26	29	10	22	25	8	20	23	7	18	21	6
160	28	31	11	24	27	9	21	24	8	20	22	7	
50	20	12	14	6	12	14	6	12	14	6	12	14	6
	40	15	17	6	13	15	6	12	14	6	12	14	6
	60	19	21	6	16	18	6	14	16	6	13	15	6
	80	21	24	8	19	21	6	17	19	6	15	17	6
	100	24	27	9	21	23	7	19	21	6	17	19	6
	120	26	30	10	23	26	8	20	23	7	19	21	6
	140	28	32	11	25	28	9	22	25	8	20	23	7
160	30	34	12	26	30	10	24	27	9	21	24	8	
60	20	12	14	6	12	14	6	12	14	6	12	14	6
	40	16	19	6	14	16	6	13	14	6	12	14	6
	60	20	23	7	17	20	6	16	18	6	14	16	6
	80	23	26	9	20	23	7	18	20	6	16	19	6
	100	26	29	10	22	25	8	20	23	7	18	21	6
	120	28	32	11	25	28	9	22	25	8	20	23	7
	140	31	35	12	27	30	10	24	27	9	22	24	8
160	33	37	13	28	32	11	25	29	10	23	26	9	
70	20	12	14	6	12	14	6	12	14	6	12	14	6
	40	18	20	6	15	17	6	14	15	6	12	14	6
	60	21	24	8	19	21	6	17	19	6	15	17	6
	80	25	28	9	21	24	8	19	22	7	18	20	6
	100	28	31	11	24	27	9	21	24	8	20	22	7
	120	30	34	12	26	30	10	24	27	9	21	24	8
	140	33	37	13	28	32	11	25	29	10	23	26	9
160	35	40	15	30	34	12	27	31	11	25	28	9	

Cost Impact: Will not increase the cost of construction
 If deck footings were correctly sized in the past, there will not be a cost increase based on this table.

Report of Committee Action Hearings

Committee Action:

Approved as Submitted

Committee Reason: The committee approved this proposal based on the proponents published reason statement.

Assembly Action:

None

Final Action Results

RB207-16

AS

Code Change No: **RB208-16**

Original Proposal

Section: R507, R507.3 (New), R507.3.1 (New), R507.3.2 (New)

Proponent: Charles Bajnai, representing Deck Code Coalition and Chesterfield County, VA; and North American Deck and Railing Association (NADRA) (bajnaic@chesterfield.gov)

Add new text as follows:

R507.3 Footings. Decks shall be supported on concrete footings or other approved structural systems designed to accommodate all loads according to Section R301.

R507.3.1 Minimum size. The minimum size of concrete footings shall be in based on the tributary area and allowable soil bearing pressure in accordance with Table R401.4.1.

R507.3.2 Minimum depth. Deck footings shall extend below the frost line specified in Table R301.2(1) in accordance with Section R403.1.4.1.

Exception: Freestanding decks need not be provided with footings that extend below the frost line.

Reason:

WHAT: This code change provides prescriptive language for where the minimum size and depth of deck footings can be found, namely in Chapter 4.

It also copies an exception from R403.1.4, that says freestanding decks, i.e. "Decks not supported by a dwelling" do not require the footings to be below the frost line.

WHY: The Deck Code Coalition (DCC) thought the deck builder should know where to look for footing size and depth information. The DCC thought it was important to have all of the deck related information in R507.

The Deck Code Coalition (DCC) is a diverse group of stakeholders, including building officials, industry associations, product manufacturers, design professionals, and academia who have worked since the 2012 IRC code development cycle in an effort to consolidate and improve deck construction methods from across the country. Our goals are threefold:

1. Consolidate existing code scattered throughout the IRC under the newly expanded Section R507. Being able to easily locate all deck related code provisions in one section equally serves the builder, code official and design professional to a safer, code-conforming deck.
2. Create realistic, fact-based, prescriptive solutions to fill critical gaps in the current deck code. Many parts of existing deck code rely on subjective interpretations by the reader leading to an inconsistent approach to meeting minimum code.
3. Maintain and promote a safer deck structure without unduly burdening the builder. In all cases the DCC want to offer safe minimum requirements without stifling the creativity of the design professional or builder.

Cost Impact: Will not increase the cost of construction

There will not be a cost impact. This code change does not alter the way deck footings have been sized under the current code.

Report of Committee Action Hearings

Committee Action:

Approved as Submitted

Committee Reason: The committee approved this proposal based on the proponents published reason statement.

Assembly Action:

None

Final Action Results

RB208-16

AS

Code Change No: **RB209-16**

Original Proposal

Section(s): R507, R507.4

Proponent: Charles Bajnai, representing Deck Code Coalition and Chesterfield County, VA; and North American Deck and Railing Association (NADRA) (bajnaic@chesterfield.gov)

Revise as follows:

SECTION R507 EXTERIOR DECKS

R507.4R507.7 Decking. Maximum allowable spacing for joists supporting decking shall be in accordance with Table ~~R507.4~~R507.7. Wood decking shall be attached to each supporting member with not less than (2) 8d threaded nails or (2) No. 8 wood screws. Other types of decking or fastener systems shall be permitted in accordance with manufacturer's installation requirements.

**TABLE ~~R507.4~~ R507.7
MAXIMUM JOIST SPACING FOR DECKING**

DECKING MATERIAL TYPE AND NOMINAL SIZE	MAXIMUM ON-CENTER JOIST SPACING	
	<u>Decking perpendicular to joist</u>	<u>Decking diagonal to joist^a</u>
1 ¹ / ₄ -inch-thick wood	16 inches	12 inches
2-inch-thick wood	24 inches	16 inches
Plastic composite	In accordance with Section R507.3	In accordance with Section R507.3

For SI: 1 inch = 25.4 mm, 1 foot = 304.8 mm, 1 degree = 0.01745 rad.

a. Maximum angle of 45 degrees from perpendicular for wood deck boards

Reason:

WHAT: This code change modifies the decking text to permit custom decking materials and custom fasteners.

WHY: The Deck Code Coalition (DCC) thought it was imperative to permit all of the new decking materials being developed over the past few years. Also the market has seen many new fasteners and fastening systems being developed.



The Deck Code Coalition (DCC) is a diverse group of stakeholders, including building officials, industry associations, product manufacturers, design professionals, and academia who have worked since the 2012 IRC code development cycle in an effort to consolidate and improve deck construction methods from across the country.

Our goals are threefold:

1. Consolidate existing code scattered throughout the IRC under the newly expanded Section R507. Being able to easily locate all deck related code provisions in one section equally serves the builder, code official and design professional to a safer, code-conforming deck.
2. Create realistic, fact-based, prescriptive solutions to fill critical gaps in the current deck code. Many parts of existing deck code rely on subjective interpretations by the reader leading to an inconsistent approach to meeting minimum code.
3. Maintain and promote a safer deck structure without unduly burdening the builder. In all cases the DCC want to offer safe minimum requirements without stifling the creativity of the design professional or builder.

Cost Impact: Will not increase the cost of construction

There is no cost impact. It may even save a bit by allowing proprietary fastening systems.

Report of Committee Action Hearings
--

Committee Action:

Approved as Submitted

Committee Reason: The committee felt this is a good update to this section as it allows alternative decking material and fastener systems.

Assembly Action:

None

Public Comments

Public Comment 1:

Paul Coats, PE CBO (pcoats@awc.org) requests Approve as Modified by this Public Comment.

Modify as follows:

R507.7 Decking. Maximum allowable spacing for joists supporting decking shall be in accordance with Table R507.7. Wood decking shall be attached to each supporting member with not less than (2) 8d threaded nails or (2) No. 8 wood screws. Other types of ~~approved~~ decking or fastener systems shall be ~~permitted~~ installed in accordance with manufacturer's installation requirements.

Commenter's Reason: The phrase "shall be permitted" is overly broad in this instance because there are no specific performance requirements for the alternative decking or fastener system. The proposed revisions add "approved" to clarify that the alternative decking or fastener system is subject to approval by the building official as are all alternative systems. Revisions also clarify that installation shall be per manufacturer's installation instructions.

Final Action Results

RB209-16

AMPC1

Code Change No: RB210-16

Original Proposal

Section: R507, R507.5, R507.5.1, R507.7

Proponent: Charles Bajnai, representing Deck Code Coalition and Chesterfield County, VA; and North American Deck and Railing Association (NADRA) (bajnaic@chesterfield.gov)

Revise as follows:

~~R507.5~~ **R507.6 Deck joists.** Maximum allowable spans for wood deck joists, as shown in Figure ~~R507.5~~ R507.6, shall be in accordance with Table ~~R507.5~~ R507.6. ~~Deck joists~~ The maximum joist spacing shall be permitted to be limited by the decking material in accordance with Table R507.4. The maximum joist cantilever not greater than one-fourth of shall be limited to the actual, adjacent joist span divided by 4 or the maximum cantilever length specified in Table R507.6, whichever is less.

~~R507.7~~ **R507.6.1 Deck joist and deck beam bearing.** The ends of each joist and beam joists shall have not less than 1¹/₂ inches (38 mm) of bearing on wood or metal and not less than 3 inches (76 mm) on concrete or masonry for the over its entire width. Joists bearing on top of the a multi-ply beam or ledger shall be fastened in accordance with Table R602.3(1). Joists bearing on top of a single ply beam or ledger shall be attached by a mechanical connector. Joist framing into the side of a beam or ledger board or beam shall be supported by approved joist hangers. Joists bearing on a beam shall be connected to the beam to resist lateral displacement.

~~R507.5.1~~ **R507.6.2 Lateral Deck joist lateral restraint at supports.** Joist ends and bearing locations shall be provided with lateral restraint to prevent rotation. Where lateral restraint is provided by joist hangers or blocking between joists, their depth shall equal not less than 60 percent of the joist depth. Where lateral restraint is provided by rim joists, they shall be secured to the end of each joist with not less than (3) 10d (3-inch x 0.128-inch) nails or (3) No. 10 x 3-inch (76 mm) long wood screws.

TABLE ~~R507.5~~ R507.6
DECK JOIST SPANS FOR COMMON LUMBER SPECIES^{fb} (ft. - in.)

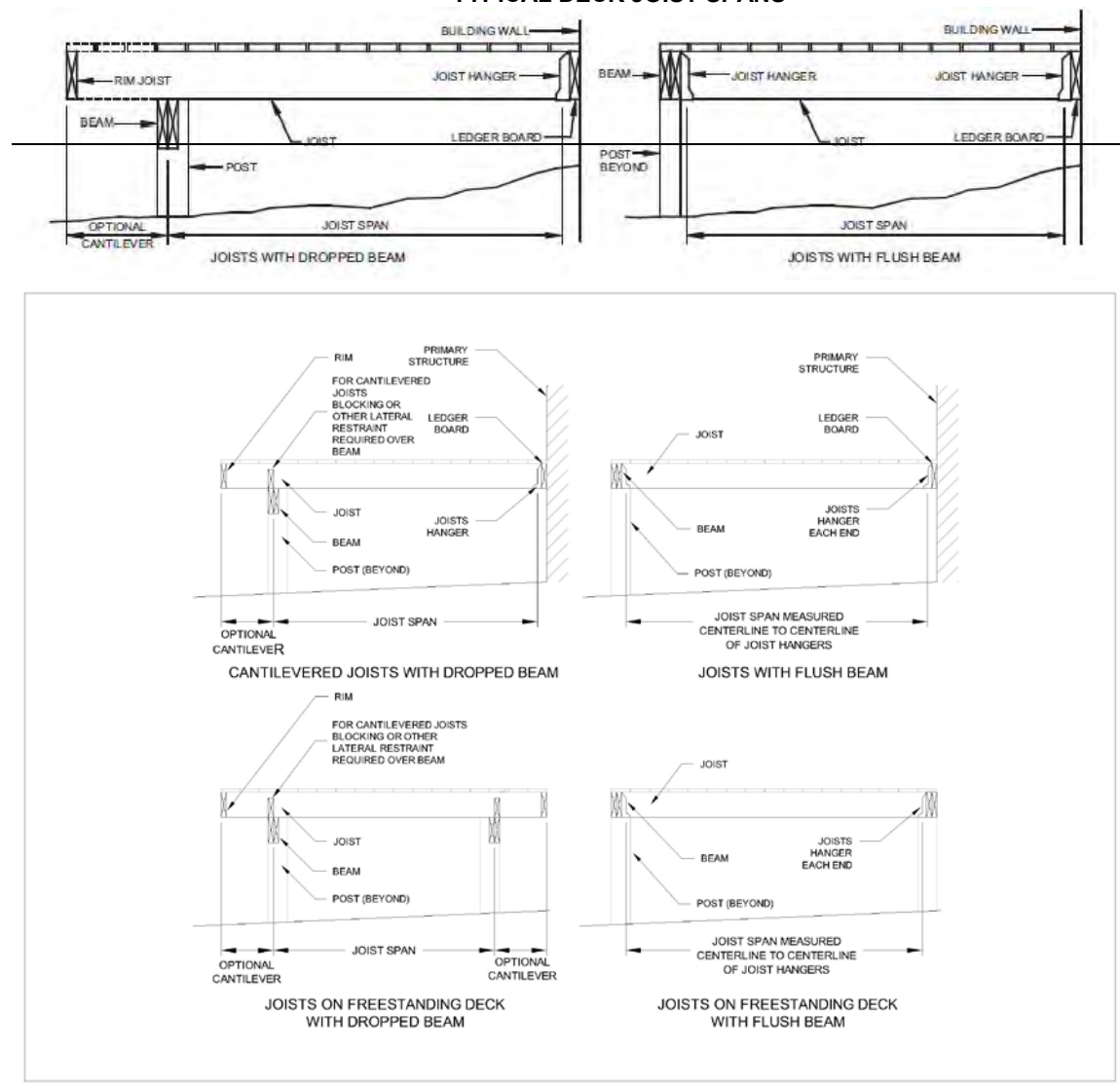
SPECIES ^a	SIZE	ALLOWABLE JOIST SPAN ^c			MAXIMUM CANTILEVER ¹		
		SPACING OF DECK JOISTS WITH NO CANTILEVER ^{b,f} (inches)			SPACING OF DECK JOISTS WITH CANTILEVERS ^c (inches)		
		12	16	24	12	16	24
Southern pine	2 x 6	9-11	9-0	7-7	<u>1-3</u>	<u>1-4</u>	<u>1-6</u>
	2 x 8	13-1	11-10	9-8	<u>2-1</u>	<u>2-3</u>	<u>2-5</u>
	2 x 10	16-2	14-0	11-5	<u>3-4</u>	<u>3-6</u>	<u>2-10</u>
	2 x 12	18-0	16-6	13-6	<u>4-6</u>	<u>4-2</u>	<u>3-4</u>
Douglas fir-larch ^d , hem-fir ^d , spruce-pine-fir ^d	2 x 6	9-6	8-8	7-2	<u>1-2</u>	<u>1-3</u>	<u>1-5</u>
	2 x 8	12-6	11-1	9-1	<u>1-11</u>	<u>2-1</u>	<u>2-3</u>
	2 x 10	15-8	13-7	11-1	<u>3-1</u>	<u>3-5</u>	<u>2-9</u>
	2 x 12	18-0	15-9	12-10	<u>4-6</u>	<u>3-11</u>	<u>3-3</u>

Redwood, western cedars, ponderosa pine ^e , red pine ^e	2 x 6	8-10	8-0	7-0	1-0	1-1	1-2
	2 x 8	11-8	10-7	8-8	1-8	1-10	2-0
	2 x 10	14-11	13-0	10-7	2-8	2-10	2-8
	2 x 12	17-5	15-1	12-4	3-10	3-9	3-1

For SI: 1 inch = 25.4 mm, 1 foot = 304.8 mm, 1 pound per square foot = 0.0479 kPa, 1 pound = 0.454 kg.

- a. No. 2 grade with wet service factor.
- b. Ground snow load, live load = 40 psf, dead load = 10 psf, $L/\Delta = 360$.
- c. Ground snow load, live load = 40 psf, dead load = 10 psf, $L/\Delta = 360$ at main span, $L/\Delta = 180$ at cantilever with a 220-pound point load applied to end.
- d. Includes incising factor.
- e. Northern species with no incising factor
- f. Cantilevered spans not exceeding the nominal depth of the joist are permitted.

**FIGURE R507.5-R507.6
TYPICAL DECK JOIST SPANS**



Reason:**WHAT:** This code change

1. Modifies the joist text, and
2. Replaces the figure, and
3. Amends the table.

WHY: The Deck Code Coalition (DCC) wanted to make several changes the this part of the code. They include:

1. The way cantilever lengths were displayed in the table. The current table is difficult to understand, and this revision more clearly explains the two limitations, namely cantilevers are limited to joist span divided by 4 or the lengths in the table, whichever is the lessor.
2. The figure was changed because the committee thought it was worthwhile to include freestanding decks in the picture, and show lateral support over the beams.
3. Splitting the beam and joist text that currently are in the same paragraph (R507.7.) regarding support and lateral restraint. The beam part of this was done by a different code submittal; this code change is for the joists.



The Deck Code Coalition (DCC) is a diverse group of stakeholders, including building officials, industry associations, product manufacturers, design professionals, and academia who have worked since the 2012 IRC code development cycle in an effort to consolidate and improve deck construction methods from across the country.

Our goals are threefold:

1. Consolidate existing code scattered throughout the IRC under the newly expanded Section R507. Being able to easily locate all deck related code provisions in one section equally serves the builder, code official and design professional to a safer, code-conforming deck.
2. Create realistic, fact-based, prescriptive solutions to fill critical gaps in the current deck code. Many parts of existing deck code rely on subjective interpretations by the reader leading to an inconsistent approach to meeting minimum code.
3. Maintain and promote a safer deck structure without unduly burdening the builder. In all cases the DCC want to offer safe minimum requirements without stifling the creativity of the design professional or builder.

Cost Impact: Will not increase the cost of construction

There is no cost impact. It could allow for longer cantilevers in some situations.

**Report of Committee Action
Hearings**

Committee Action:

Approved as Submitted

Committee Reason: The committee approved this proposal based on the proponents published reason statement. This change provides clarity for freestanding decks.

Assembly Action:

None

Final Action Results

RB210-16

AS

Code Change No: **RB212-16**

Original Proposal

Section: R507, R507.8, R507.8.1

Proponent: Charles Bajnai, representing Deck Code Coalition and Chesterfield County, VA; and North American Deck and Railing Association (NADRA) (bajnaic@chesterfield.gov)

Revise as follows:

~~R507.8~~ R507.4 Deck posts. For single-level wood-framed decks with beams sized in accordance with Table R507.6, deck post size shall be in accordance with Table ~~R507.8~~R507.4.

TABLE ~~R507.8~~ R507.4
DECK POST HEIGHT^a

DECK POST SIZE	MAXIMUM HEIGHT ^{a, b}
4 × 4	6'-9" ^c
4 × 6	8'
6 × 6	14'
<u>8 × 8</u>	<u>14'</u>

For SI: 1 foot = 304.8 mm.

a. Measured to the underside of the beam.

b. Based on 40 psf live load.

c. The maximum permitted height is 8'-0" for one-ply and two-ply beams. 6'-9" is the maximum permitted height for three-ply beams on post cap.

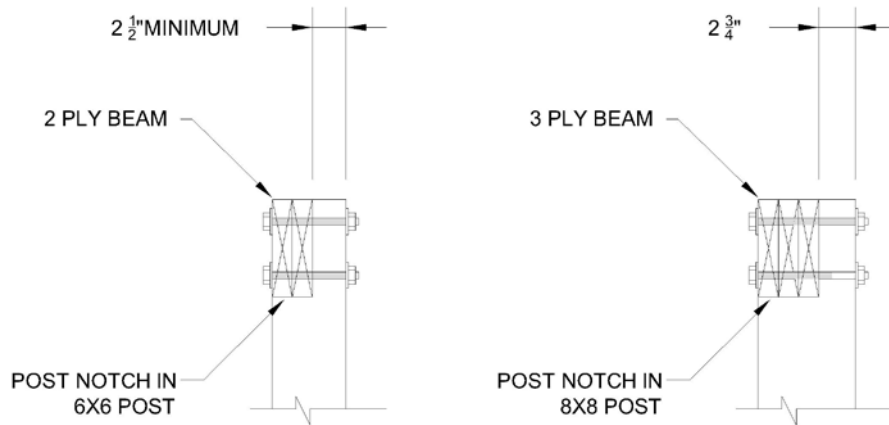
~~R507.8.1~~ R507.4.1 Deck post to deck footing connection. Posts shall bear on footings in accordance with Section R403 and Figure ~~R507.8.1~~R507.4.1. Posts shall be restrained to prevent lateral displacement at the bottom support. Such lateral restraint shall be provided by manufactured connectors installed in accordance with Section R507 and the manufacturers' instructions or a minimum post embedment of 12 inches (305 mm) in surrounding soils or concrete piers.

FIGURE ~~R507.8.1~~ R507.4.1
TYPICAL DECK POSTS TO DECK FOOTINGS
(Existing code figure not shown for clarity)

Reason:

WHAT: This code proposal relocates the deck post section. Also, it adds 8x8 posts to the table.

WHY: The Deck Code Coalition (DCC) thought it was necessary to add 8x8 posts to the table because three ply beams cannot be supported by notched 6x6 posts – that is, they require 2 1/2" wide support leg which can only be achieved with a 8x8 post.



The Deck Code Coalition (DCC) is a diverse group of stakeholders, including building officials, industry associations, product manufacturers, design professionals, and academia who have worked since the 2012 IRC code development cycle in an effort to consolidate and improve deck construction methods from across the country. Our goals are threefold:

1. Consolidate existing code scattered throughout the IRC under the newly expanded Section R507. Being able to easily locate all deck related code provisions in one section equally serves the builder, code official and design professional to a safer, code-conforming deck.
2. Create realistic, fact-based, prescriptive solutions to fill critical gaps in the current deck code. Many parts of existing deck code rely on subjective interpretations by the reader leading to an inconsistent approach to meeting minimum code.
3. Maintain and promote a safer deck structure without unduly burdening the builder. In all cases the DCC want to offer safe minimum requirements without stifling the creativity of the design professional or builder.

Cost Impact: Will not increase the cost of construction
There is no cost impact. This proposal adds more options to the table.

Report of Committee Action Hearings

Committee Action:

Approved as Submitted

Committee Reason: The committee approved this proposal based on the proponents published reason statement.

Assembly Action:

None

Final Action Results

RB212-16

AS

Code Change No: **RB213-16**

Original Proposal

Section: R507.8, R507.8.1

Proponent: Charles Bajnai, representing Deck Code Coalition and Chesterfield County, VA; and North American Deck and Railing Association (NADRA) (bajnaic@chesterfield.gov)

Revise as follows:

~~R507.8~~ **R507.4 Deck posts.** For single-level wood-framed decks with beams sized in accordance with Table R507.6, deck post size shall be in accordance with Table ~~R507.8~~ **R507.4**.

TABLE ~~R507.8~~ **R507.4**
DECK POST HEIGHT^a

DECK POST SIZE	MAXIMUM HEIGHT ^a
4 × 4	8'
4 × 6	8'
6 × 6	14'

For SI: 1 foot = 304.8 mm.

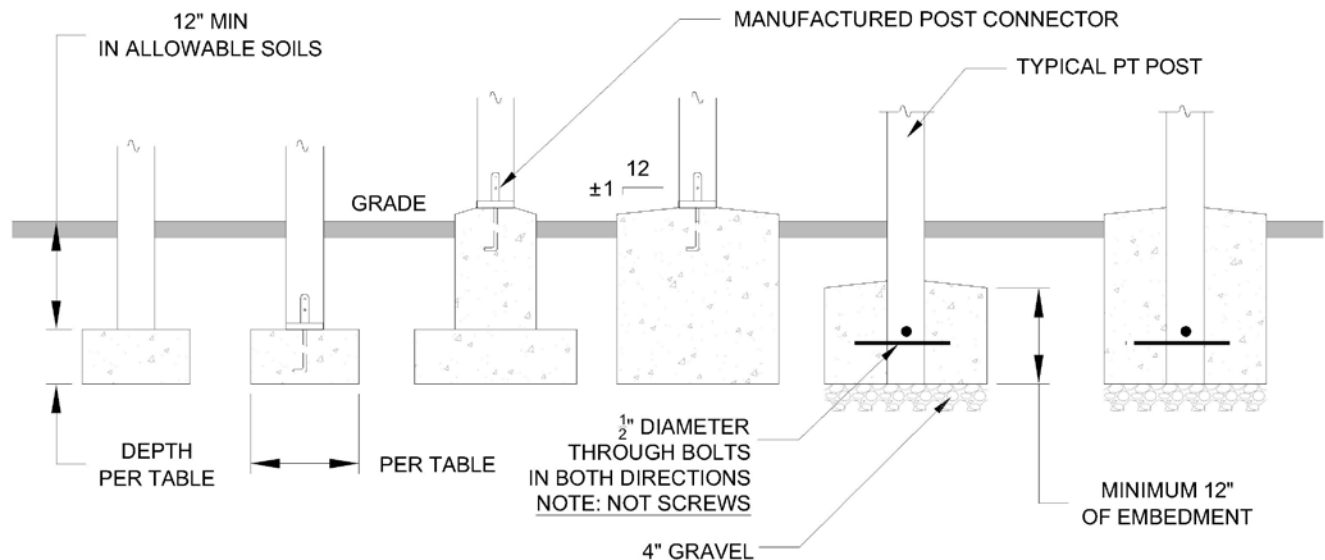
a. Measured to the underside of the beam.

~~R507.8.1~~ **R507.4.1 Deck post to deck footing.** Posts shall bear on footings in accordance with Section R403 and Figure ~~R507.8.1~~ **R507.4.1**. Posts shall be restrained to prevent lateral displacement at the bottom support. Such lateral restraint shall be provided by manufactured connectors installed in accordance with Section R507 and the manufacturers' instructions or a minimum post embedment of 12 inches (305 mm) in surrounding soils or concrete piers.

Exception: Where expansive, compressible, shifting or other questionable soils are present, surrounding soils shall not be relied upon for lateral support.

FIGURE R507.8.1 R507.4.1
(TYPICAL DECK POSTS TO DECK FOOTINGS)

(Existing code figure not shown for clarity)



NOTE:
 POSTS MUST BE CENTERED ON OR IN FOOTING

Reason:

WHAT:

1. This code proposal relocates the deck post section.
2. It also adds an exception that says deck posts cannot use embedded soil for lateral support if the surrounding soils are problematic.
3. The figure was changed to better reflect how the connection between the deck post and the footing is supposed to be.

WHY:

1. Based on the Deck Code Coalition's experience, they did not think that embedding posts 12" in surrounding soil would adequately prevent lateral displacement of the deck post for all situations. The exception was added to cover deck posts in problematic soils.
2. The committee did not think that the existing figure was accurate or depicted how the connection between the post and the footing was supposed to work. The first two existing figures shows posts just sitting on a concrete piers without any lateral restraint - connector.

The Deck Code Coalition (DCC) is a diverse group of stakeholders, including building officials, industry associations, product manufacturers, design professionals, and academia who have worked since the 2012 IRC code development cycle in an effort to consolidate and improve deck construction methods from across the country.

Our goals are threefold:

1. Consolidate existing code scattered throughout the IRC under the newly expanded Section R507. Being able to easily locate all deck related code provisions in one section equally serves the builder, code official and design professional to a safer, code-conforming deck.
2. Create realistic, fact-based, prescriptive solutions to fill critical gaps in the current deck code. Many parts of existing deck code rely on subjective interpretations by the reader leading to an inconsistent approach to meeting minimum code.
3. Maintain and promote a safer deck structure without unduly burdening the builder. In all cases the DCC want to offer safe minimum requirements without stifling the creativity of the design professional or builder.

Cost Impact: Will not increase the cost of construction

There is no cost impact. The code already requires lateral restraint at the bottom of the footings.

**Report of Committee Action
Hearings**

Committee Action:

Approved as Submitted

Committee Reason: This proposal adds a needed change that prohibits certain soils surrounding the deck post from providing the lateral support at the bottom.

Assembly Action:

None

Final Action Results

RB213-16

AS

Code Change No: RB214-16

Original Proposal

Section: R507, R507.8, R507.8.1

Proponent: Charles Bajnai, representing Deck Code Coalition and Chesterfield County, VA; and North American Deck and Railing Association (NADRA) (bajnaic@chesterfield.gov)

Revise as follows:

~~R507.8~~ R507.4 Deck posts. For single-level wood-framed decks with beams sized in accordance with Table R507.6, deck post size shall be in accordance with Table ~~R507.8~~ R507.4.

**TABLE ~~R507.8~~ R507.4
DECK POST HEIGHT^a**

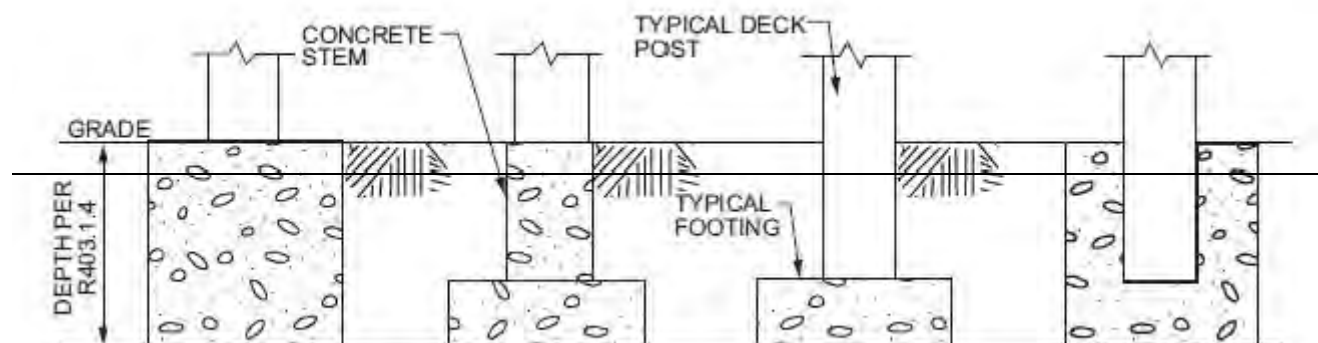
DECK POST SIZE	MAXIMUM HEIGHT ^a
4 × 4	8'
4 × 6	8'
6 × 6	14'

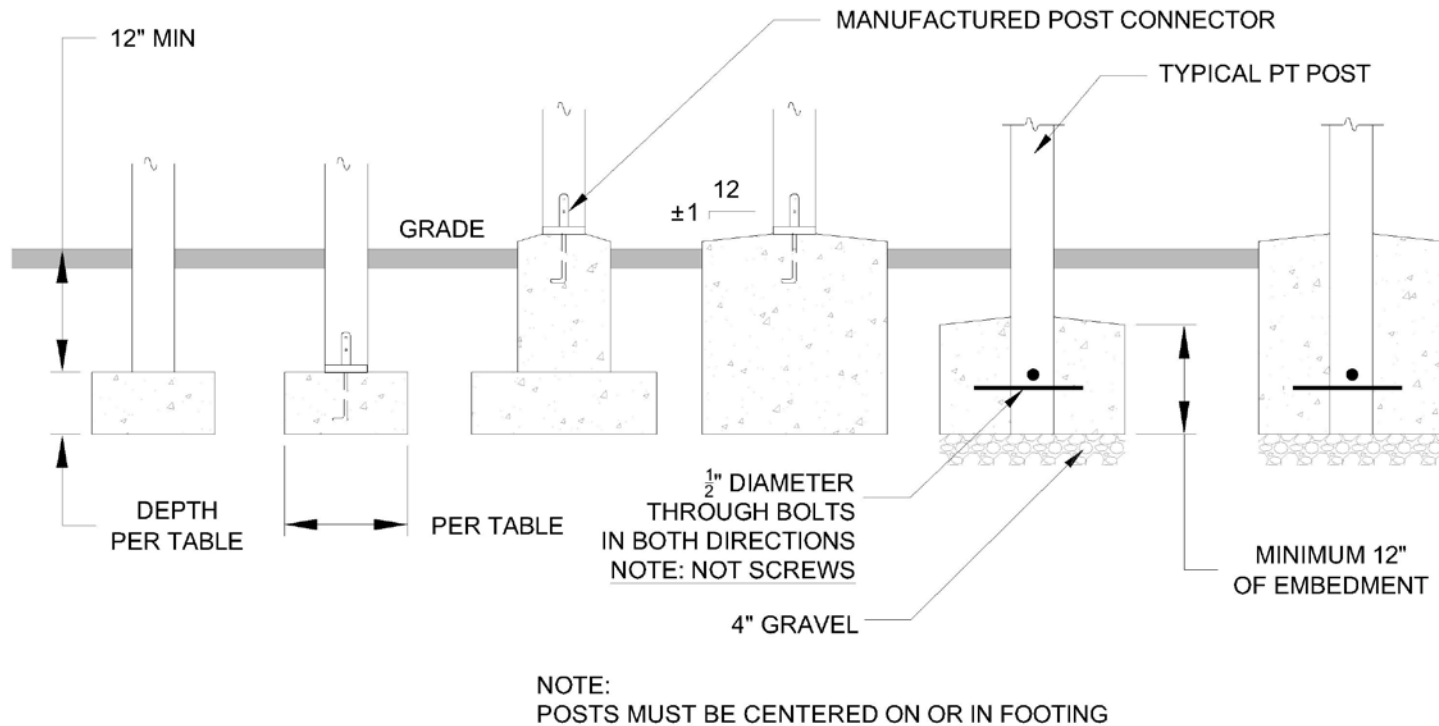
For SI: 1 foot = 304.8 mm.

a. Measured to the underside of the beam.

~~R507.8.1~~ R507.4.1 Deck post to deck footing connection. Posts shall bear on footings in accordance with Section R403 and Figure R507.8.1. Posts shall be restrained to prevent lateral displacement at the bottom support. ~~Such~~ Where posts bear on concrete footings in accordance with Section R403 and Figure R507.4.1, such lateral restraint shall be provided by manufactured connectors installed in accordance with Section R507 and the manufacturers' instructions or a minimum post embedment of 12 inches (305 mm) in surrounding soils or concrete piers. Other footing systems shall be permitted.

**FIGURE ~~R507.8.1~~ R507.4.1
TYPICAL DECK POSTS TO DECK FOOTINGS ~~Deck post to deck footing connection.~~**



**Reason:****WHAT:**

1. This code change eliminates the wording that posts have to bear on footings. The new wording specifically allows new proprietary footing systems which may or may not have footing per se.
2. This code change also provides a better drawing of how posts are to be attached to footings.

WHY:

1. The Deck Code Coalition (DCC) thought the current deck post to footing figure did not adequately depict how the lateral restraint at the bottom of the post was achieved.
2. The DCC also thought that the wording was too restrictive in that it required all deck posts to bear on concrete footings. The committee did not want to limit options on how to support a deck post; there are new methods, such as helical piers and other new products that can do the job as well.





The Deck Code Coalition (DCC) is a diverse group of stakeholders, including building officials, industry associations, product manufacturers, design professionals, and academia who have worked since the 2012 IRC code development cycle in an effort to consolidate and improve deck construction methods from across the country.

Our goals are threefold:

1. Consolidate existing code scattered throughout the IRC under the newly expanded Section R507. Being able to easily locate all deck related code provisions in one section equally serves the builder, code official and design professional to a safer, code-conforming deck.
2. Create realistic, fact-based, prescriptive solutions to fill critical gaps in the current deck code. Many parts of existing deck code rely on subjective interpretations by the reader leading to an inconsistent approach to meeting minimum code.
3. Maintain and promote a safer deck structure without unduly burdening the builder. In all cases the DCC want to offer safe minimum requirements without stifling the creativity of the design professional or builder.

Cost Impact: Will not increase the cost of construction

There is no cost impact. The code already requires lateral restraint at the bottom of the footings. It may actually reduce the cost by allowing optional proprietary footing systems.

Report of Committee Action Hearings
--

Committee Action:

Approved as Submitted

Committee Reason: The committee approved this proposal based on the proponents published reason statement. Also, it allows alternate methods to be used for deck footings.

Assembly Action:

None

Final Action Results

RB214-16

AS

Code Change No: **RB217-16**

Original Proposal

Section(s): R602.1.11 (New), R610.10, R610.10.1, R610.2, R610.3, R610.3.1, R610.3.2, R610.3.3, R610.3.4, R610.3.5, R610.3.6, R610.4, R610.4.1, R610.5, R610.5.1, R610.5.2, R610.5.3, R610.5.3 (New), R610.5.4 (New), R610.5.6 (New), R610.6, R610.7, R610.8, R610.9

Proponent: Edward Keith, representing APA- The Engineered Wood Association (ed.keith@apawood.org)

Add new text as follows:

R602.1.11 Structural insulated panels. Structural insulated panels shall be manufactured and identified in accordance with ANSI/APA PRS 610.1

Revise as follows:

R610.2 Applicability limits. The provisions of this section shall control the construction of exterior structural insulated panel walls and interior load-bearing structural insulated panel walls for buildings not greater than 60 feet (18 288 mm) in length perpendicular to the joist or truss span, not greater than 40 feet (12 192 mm) in width parallel to the joist or truss span and not greater than two stories in height with each wall not greater than 10 feet (3048 mm) high. Exterior walls installed in accordance with the provisions of this section shall be considered as load-bearing walls. Structural insulated panel walls constructed in accordance with the provisions of this section shall be limited to sites where the ultimate design wind speed (V_{ult}) is not greater than 155 miles per hour (69 m/s), Exposure B or 140 miles per hour (63 m/s) Exposure C, the ground snow load is not greater than 70 pounds per square foot (3.35 kPa), and the seismic design category is A, B or C.

R610.3.4

~~MINIMUM PROPERTIES FOR POLYURETHANE INSULATION USED AS SIPS CORE~~

For SI: 1 pound per cubic foot = 16.02 kg/m³, 1 pound per square inch = 6.895 kPa, °C = [(°F) - 32]1.8.

Delete without substitution:

~~**R610.3.2 Facing.** Facing materials for SIPs shall be wood structural panels conforming to DOC PS 1 or DOC PS 2, each having a minimum nominal thickness of 7/16 inch (11 mm) and shall meet the additional minimum properties specified in Table R610.3.2. Facing shall be identified by a grade mark or certificate of inspection issued by an approved agency.~~

R610.3.2

~~MINIMUM PROPERTIES^a FOR ORIENTED STRAND BOARD FACER MATERIAL IN SIP WALLS~~

For SI: 1 inch = 25.4 mm, 1 lbf-in²/ft = 9.415 × 10⁻⁶ kPa/m, 1 lbf-in/ft = 3.707 × 10⁻⁴ kN/m, 1 lbf/ft = 0.0146 N/mm, 1 pound per cubic foot = 16.018 kg/m³.

a. Values listed in Table R610.3.2 are qualification test values and are not to be used for design purposes.

b. Mean test value shall be in accordance with Section 7.6 of DOC PS 2.

c. Characteristic test value (5th percent with 75% confidence).

d.—Density shall be based on oven-dry weight and oven-dry volume.

R610.3.3 Adhesive. Adhesives used to structurally laminate the foam plastic insulation core material to the structural wood facers shall conform to ASTM D 2559 or approved alternative specifically intended for use as an adhesive used in the lamination of structural insulated panels. Each container of adhesive shall bear a label with the adhesive manufacturer's name, adhesive name and type and the name of the quality assurance agency.

R610.3.4 R610.3.2 Lumber. *No change to text.*

Revise as follows:

R610.3.5 R610.3.3 SIP screws. *No change to text.*

R610.3.6 R610.3.4 Nails. *No change to text.*

R610.4 SIP wall panels. SIPs shall comply with Figure R610.4 and shall have minimum panel thickness in accordance with Tables R610.5(1) and R610.5(2) for above-grade walls. SIPs shall be identified by grade mark or certificate of inspection issued by an *approved agency in accordance with ANSI/APA PRS 610.1.*

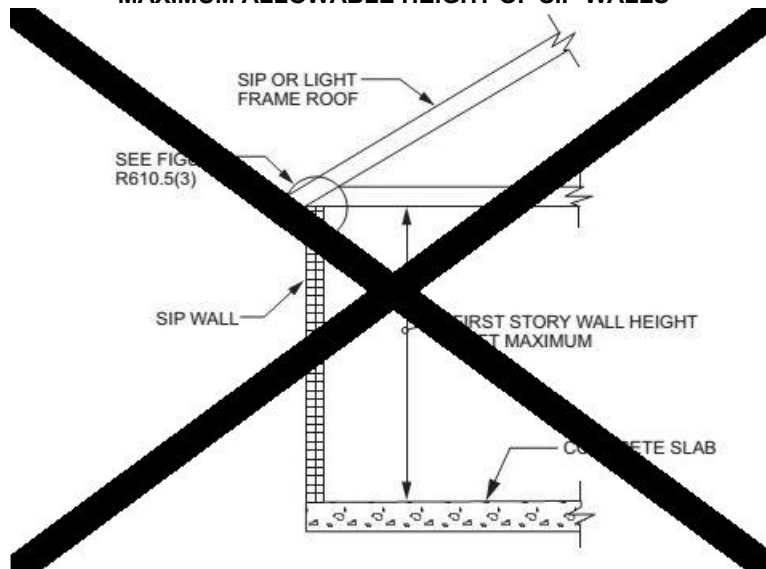
Delete without substitution:

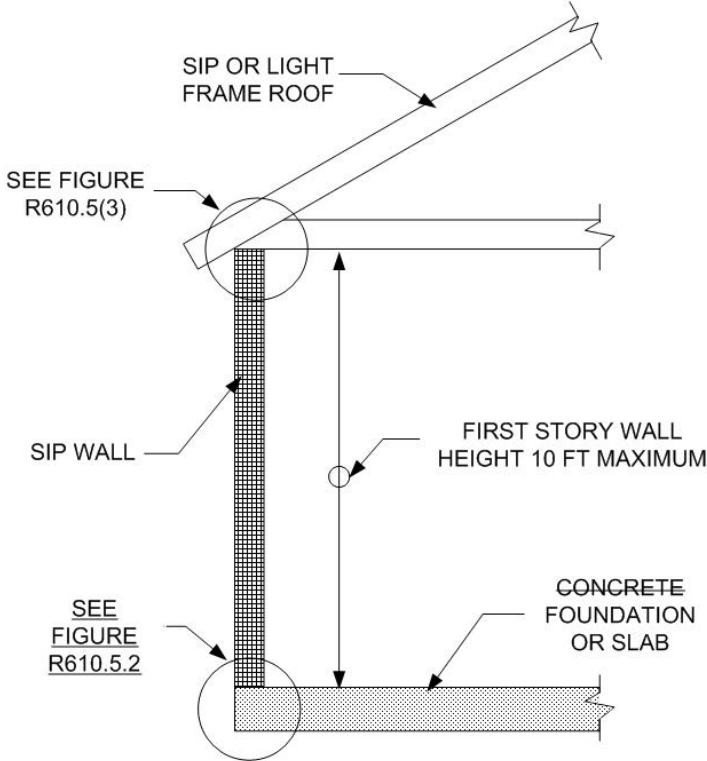
R610.4.1 Labeling. Panels shall be identified by grade mark or certificate of inspection issued by an approved agency. Each (SIP) shall bear a stamp or label with the following minimum information:

1. Manufacturer name/logo.
2. Identification of the assembly.
3. Quality assurance agency.

Delete and substitute as follows:

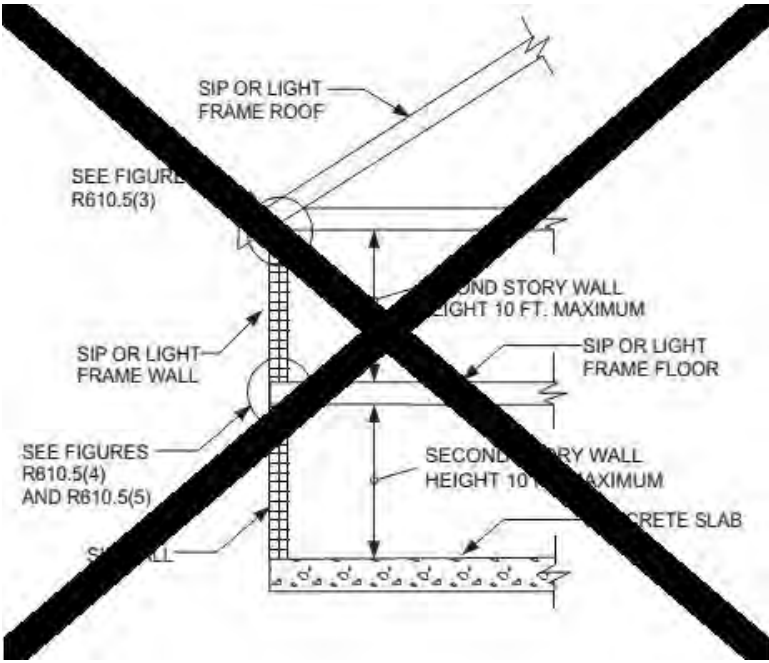
**FIGURE R610.5 (1)
MAXIMUM ALLOWABLE HEIGHT OF SIP WALLS**

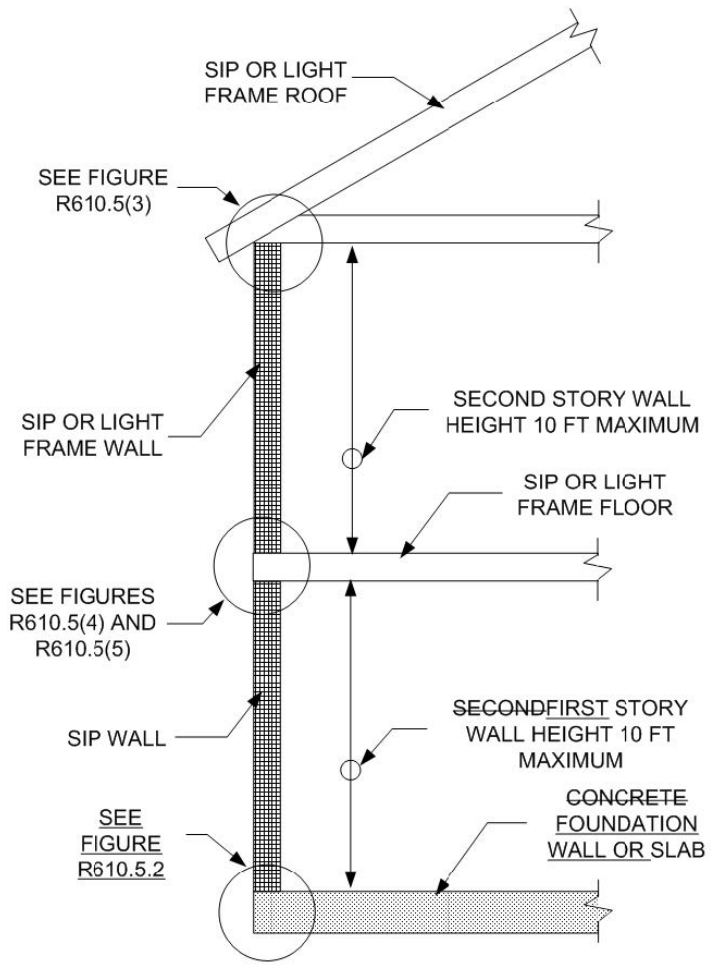




For SI: 1 foot = 304.8 mm.

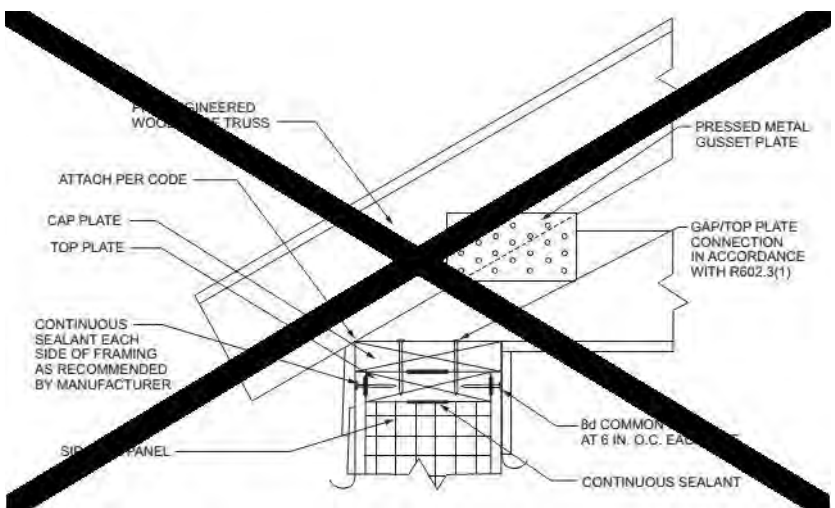
**FIGURE R610.5 (2)
MAXIMUM ALLOWABLE HEIGHT OF SIP WALLS**

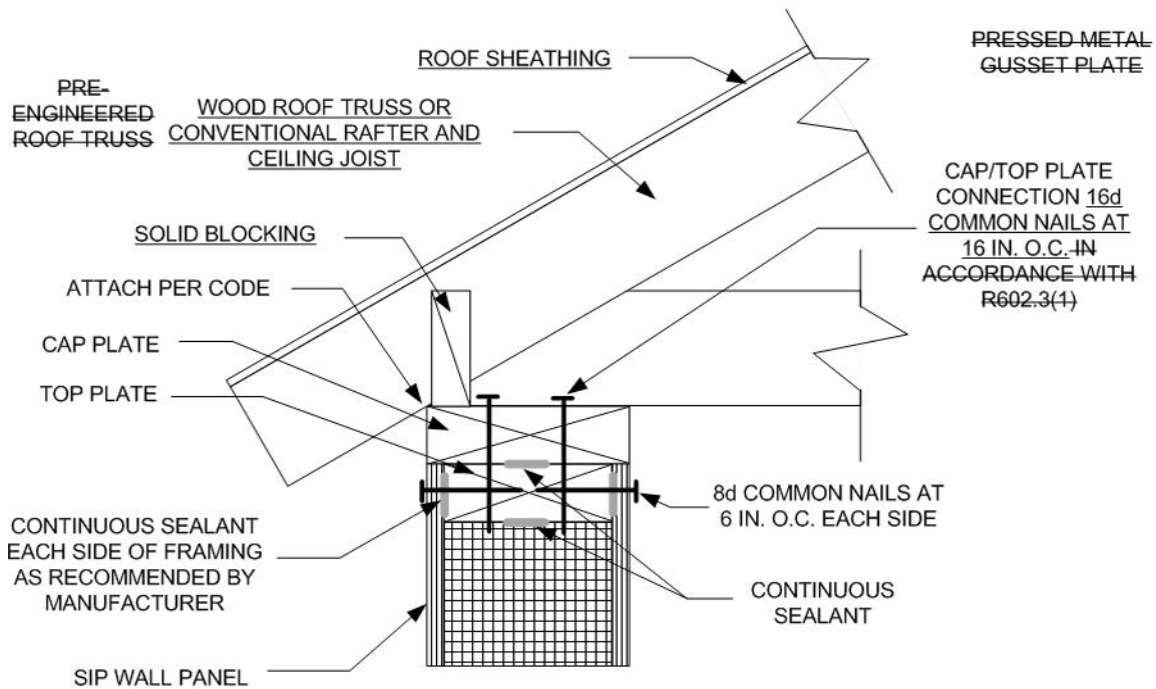




For SI: 1 inch = 25.4 mm

FIGURE R610.5 (3)
TRUSSED ROOF TRUSS OR CONVENTIONAL RAFTER TO TOP PLATE CONNECTION

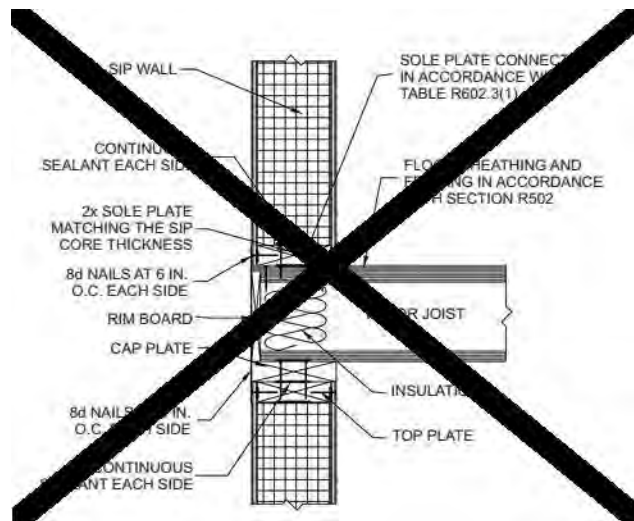


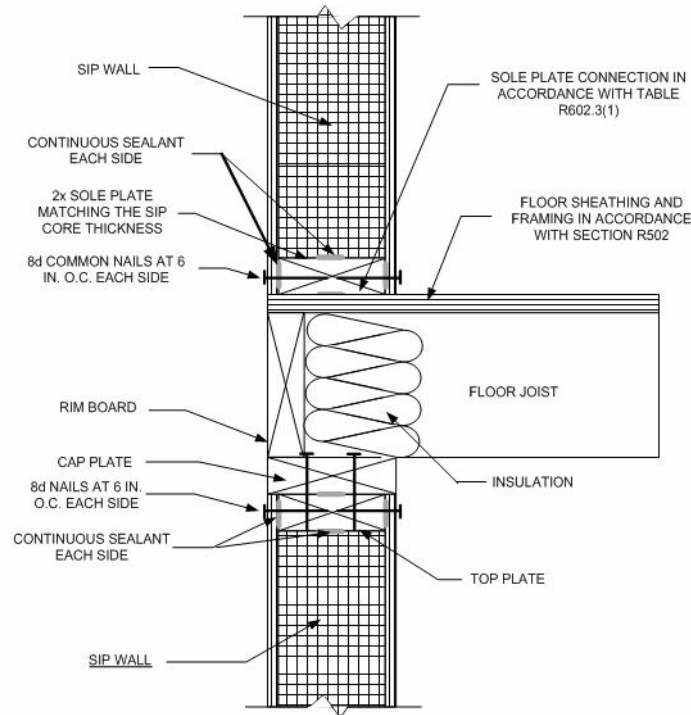


For SI: 1 inch = 25.4 mm.

Note: Figures illustrate SIP-specific attachment requirements. Other connections shall be made in accordance with Tables R602.3(1) and (2) as appropriate.

FIGURE R610.5 (4)
SIP WALL-TO-WALL PLATFORM FRAME CONNECTION

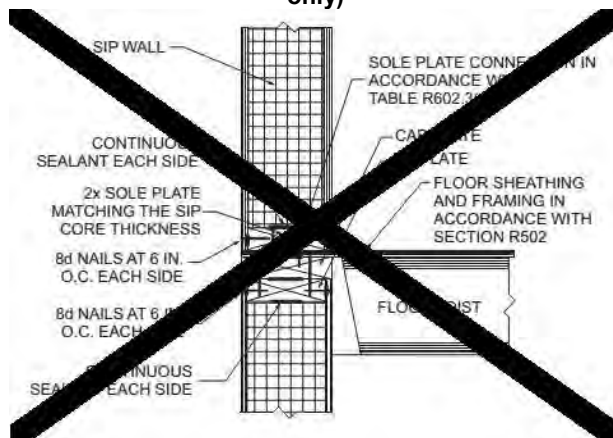


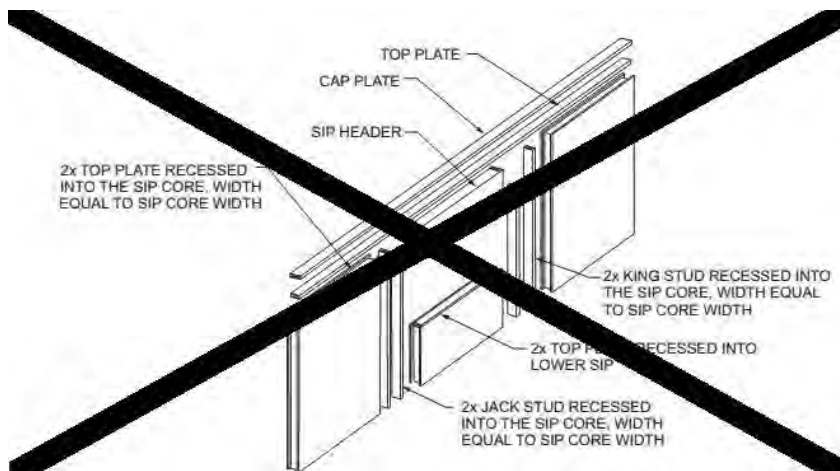
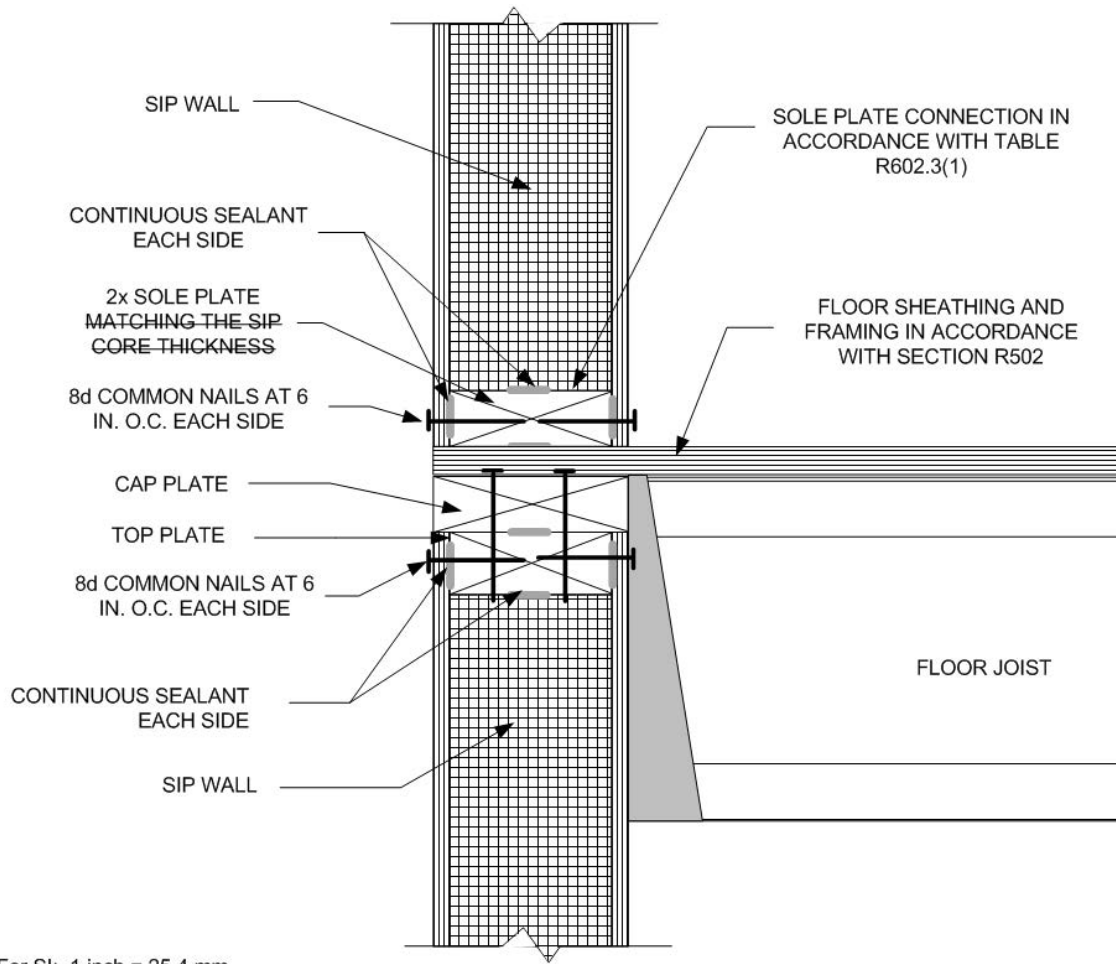


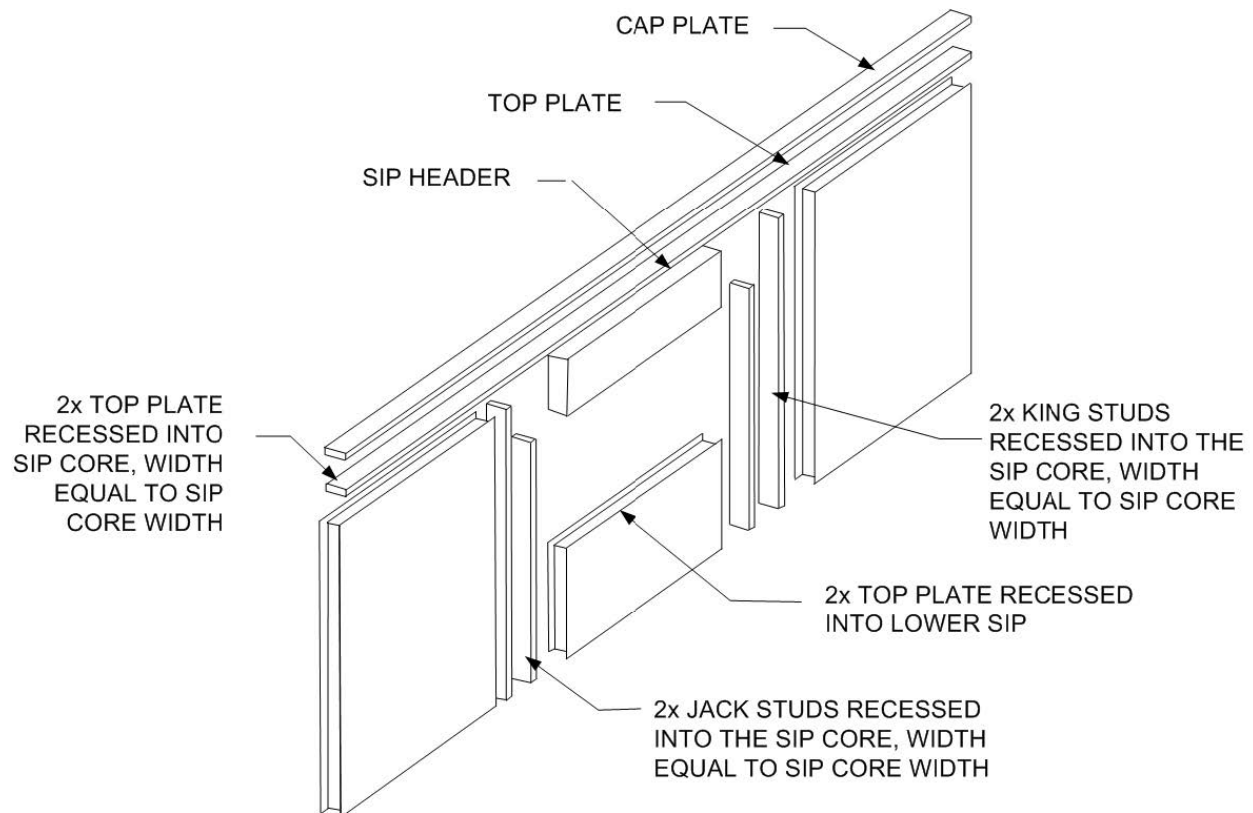
For SI: 1 inch = 25.4 mm.

Note: Figures illustrate SIP-specific attachment requirements. Other connections shall be made in accordance with Tables R602.3(1) and (2), as appropriate.

FIGURE R610.5 (5)
SIP WALL-TO-WALL BALLOON-HANGING FLOOR FRAME CONNECTION (I-Joist floor shown for illustration only)







For SI: 1 inch = 25.4 mm.

Notes:

1. Top plates shall be continuous over header.
2. Lower 2x top plate shall have a width equal to the SIP core width and shall be recessed into the top edge of the panel. Cap plate shall be placed over the recessed top plate and shall have a width equal to the SIPs width.
3. SIP facing surfaces shall be nailed to framing and cripples with 8d common or galvanized box nails spaced 6 inches on center.
4. Galvanized nails shall be hot-dipped or tumbled. Framing shall be attached in accordance to Section R602.3(1) unless otherwise provide for in Section R610.

Add new text as follows:

R610.5.3 Panel to panel connection. SIPs shall be connected at vertical in-plane joints in accordance with Figure R610.8 or by other approved methods.

R610.5.4 Corner framing. Corner framing of SIP walls shall be constructed in accordance with Figure R610.9.

Revise as follows:

R610.5.3~~R610.5.5~~ Wall bracing. SIP walls shall be braced in accordance with Section R602.10. SIP walls shall be considered continuous wood structural panel sheathing (bracing Method CS-WSP) for purposes of computing required bracing. SIP walls shall meet the requirements of Section R602.10.4.2 except that SIP corners shall be fabricated as shown in Figure R610.9. Where SIP walls are used for wall bracing, the SIP bottom plate shall be attached to wood framing below in accordance with Table R602.3(1).

Add new text as follows:

R610.5.6 Thermal barrier. SIP walls shall be separated from the interior of a building by an approved thermal barrier in accordance with Section R316.4.

Delete without substitution:

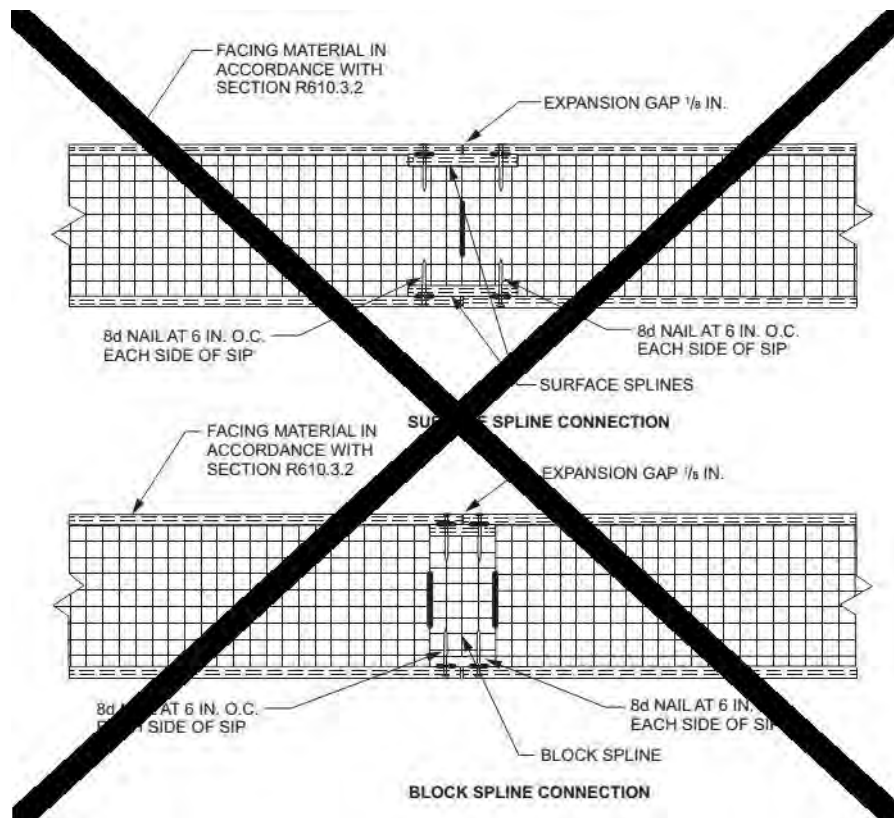
R610.8 Connection. SIPs shall be connected at vertical in-plane joints in accordance with Figure R610.8 or by other approved methods.

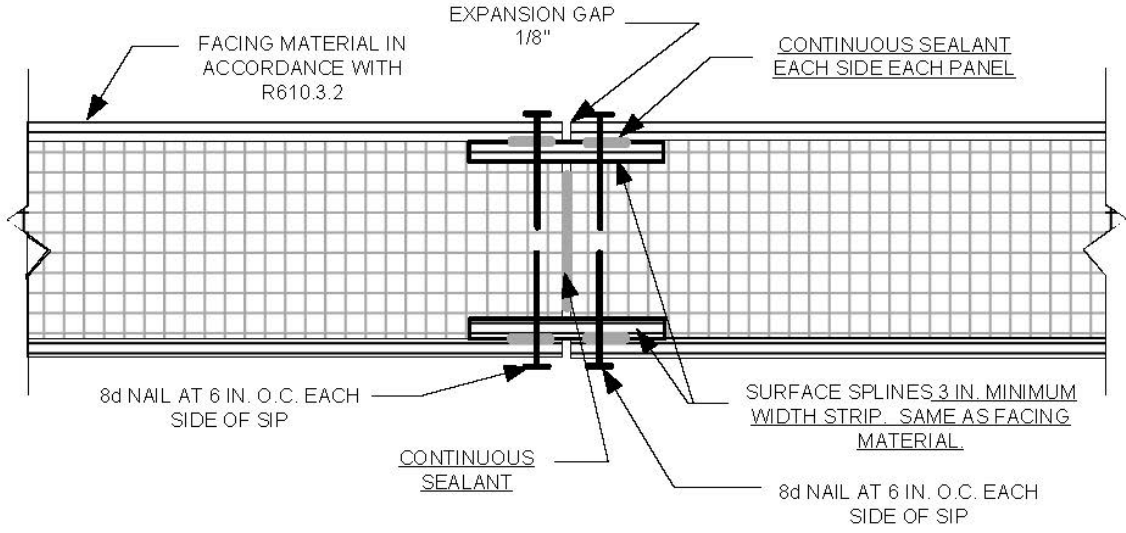
Revise as follows:

R610.10 R610.8 Headers. SIP headers shall be designed and constructed in accordance with Table R610.10 R610.8 and Figure R610.5.1. SIP headers shall be continuous sections without splines. Headers shall be not less than 11 7/8 inches (302 mm) deep. Headers longer than 4 feet (1219 mm) shall be constructed in accordance with Section R602.7. The strength axis of the facers on the header shall be oriented horizontally.

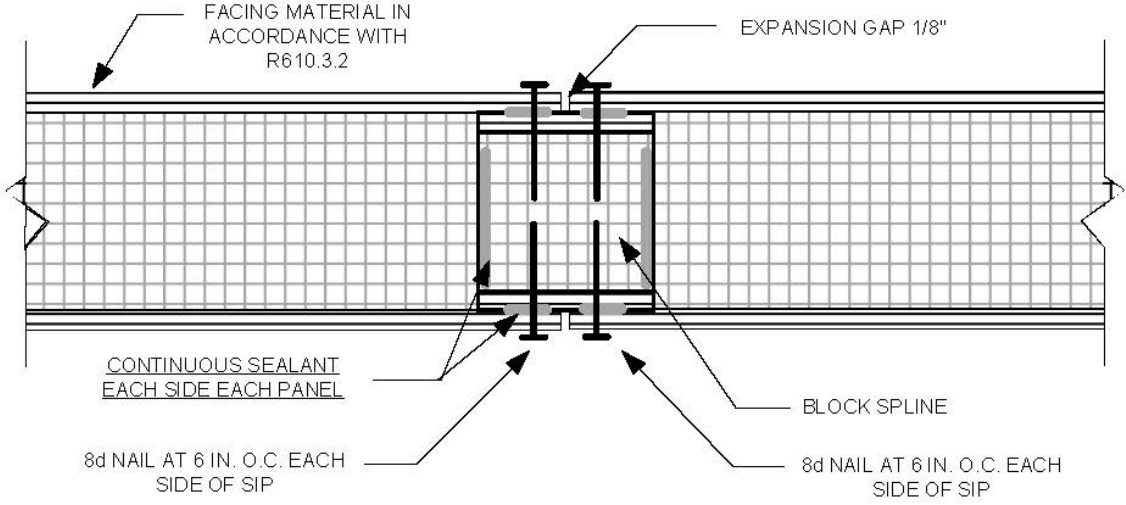
Delete and substitute as follows:

FIGURE R610.8
TYPICAL SIP WALL PANEL-TO-PANEL CONNECTION DETAILS FOR VERTICAL IN-PLANE JOINTS





SURFACE SPLINE CONNECTION



BLOCK SPLINE CONNECTION

For SI: 1 inch = 25.4 mm.

TABLE R610.10-R610.8
MAXIMUM SPANS FOR 11-⁷/₈-INCH-DEEP INCH OR DEEPER SIP HEADERS (feet)^a

LOAD CONDITION	SNOW LOAD (psf)	BUILDING width (feet)				
		24	28	32	36	40
Supporting roof only	20	4	4	4	4	2
	30	4	4	4	2	2
	50	2	2	2	2	2
	70	2	2	2	N/ADR	N/ADR
Supporting roof and one-story	20	2	2	N/ADR	N/ADR	N/ADR
	30	2	2	N/ADR	N/ADR	N/ADR
	50	2	N/ADR	N/ADR	N/ADR	N/ADR
	70	N/ADR	N/ADR	N/ADR	N/ADR	N/ADR

For SI: 1 inch = 25.4 mm, 1 foot = 304.8 mm, 1 pound per square foot = 0.0479 kPa.

N/A = Not Applicable.

a. Design assumptions:

Maximum deflection criterion: $L/360-240$. Maximum roof dead load: 10 psf.

Maximum ceiling load: 5 psf. Maximum ceiling live load: 20 psf.

Maximum second-floor live load: 30 psf. Maximum second-floor dead load: 10 psf.

Maximum second-floor dead load from walls: 10 psf

Maximum first floor dead load: 10 psf.

Wind loads based on Table R301.2(2).

Strength axis of facing material applied horizontally.

DR = Design Required

b. Building width is in the direction of horizontal framing members supported by the header.

c. The table provides for roof slopes between 3:12 and 12:12.

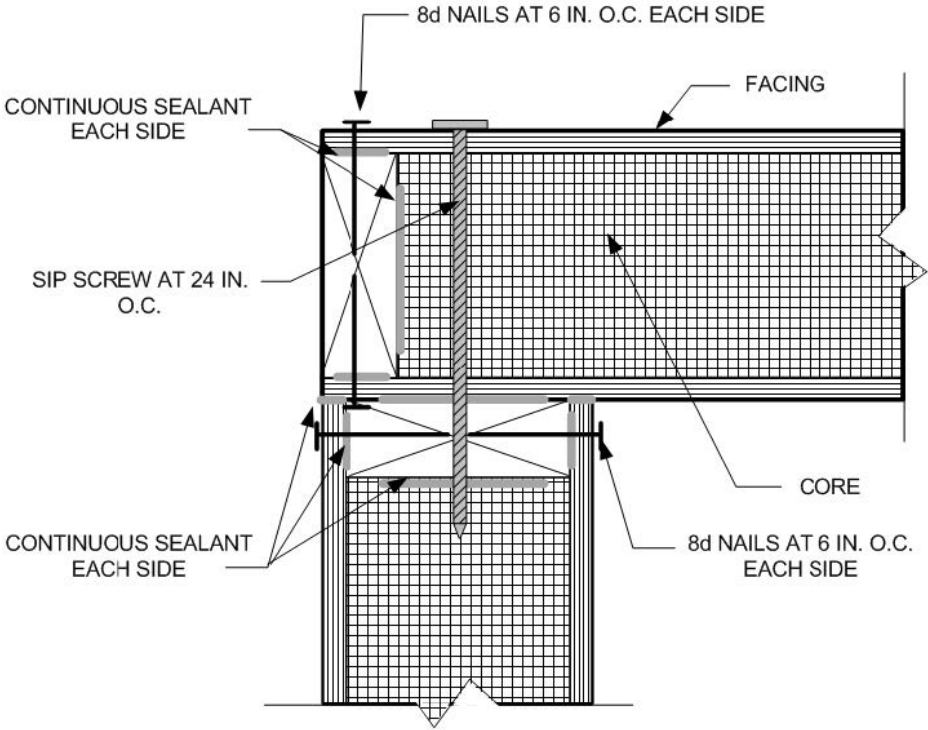
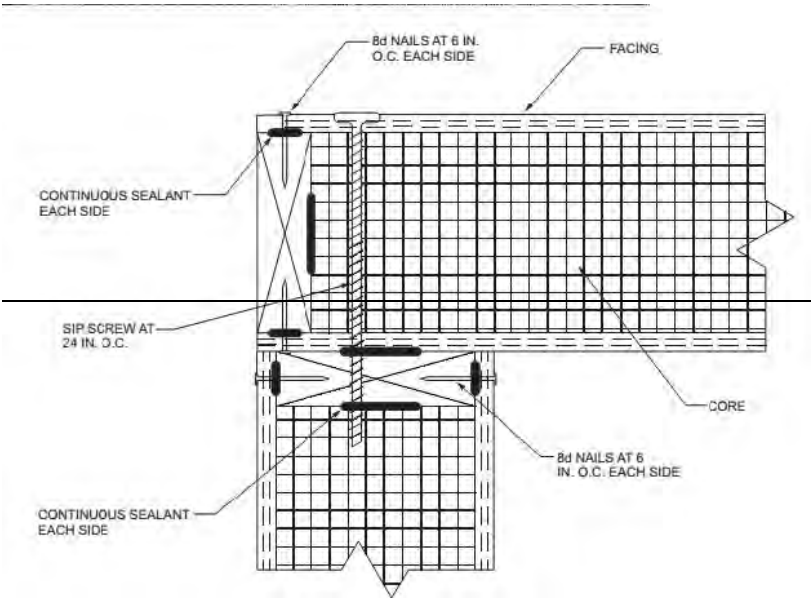
d. The maximum roof overhang is 24 inches (610 mm).

Delete without substitution:

~~**R610.9 Corner framing.** Corner framing of SIP walls shall be constructed in accordance with Figure R610.9.~~

Delete and substitute as follows:

**FIGURE R610.9
SIP CORNER FRAMING DETAIL**



For SI: 1 inch = 25.4 mm.

Delete without substitution:

R610.3.1 Core. The core material shall be composed of foam plastic insulation meeting one of the following requirements:

1. ASTM C 578 and have a minimum density of 0.90 pounds per cubic feet (14.4 kg/m³).
2. Polyurethane meeting the physical properties shown in Table R610.3.1.
3. An *approved* alternative.

All cores shall meet the requirements of Section R316.

Reference standards type: This reference standard is new to the ICC Code Books
Add new standard(s) as follows:

ANSI/APA PRS 610.1. Standard for Performance-Rated Structural Insulated Panels in Wall Applications.

Reason: The proposal is a minor reorganization and clarification of the Structural Insulated Panels (SIPs) section. The intention is to add clarity to the proposal as it is currently written. The original SIP language was based on the HUD document Prescriptive Method for Structural Insulated Panels (SIPs) Used in Wall Systems in Residential Construction. Since the inclusion of SIPs in the IRC, there have been several changes that have revised the SIP requirements. However, in some instances, the changes do not match the language used in other materials (wood, cold formed steel, etc.). Proposed changes are intended to bring the SIPs provisions more in line with the other sections of the IRC.

In addition, ANSI/APA PRS 610.1, Standard for Performance-Rated Structural Insulated Panels in Wall Applications, a consensus-based document is proposed for addition to the 2018 IRC. As a result, much of the detailed information currently in the IRC with respect to SIP core, facers and adhesive requirements may now be taken out of the IRC. (Free downloads of this new standard are available at <http://www.apawood.org/registrationpop?pubID=f0e25ef1-d7fe-42e0-9e08-0291b94efb04>)

To summarize the changes:

- Section R610.2 – added "square" to the snow load such that it reads "pounds per square foot". The SI conversion is correct as shown.
- Section R610.3.1 – Removes SIPs core details from the body of the code and references ANSI/APA PRS 610.1.
- Section R610.3.2 – Removes SIPs facer details from the body of the code and references ANSI/APA PRS 610.1.
- Section R610.3.3 – Removes SIPs adhesive details from the body of the code and references ANSI/APA PRS 610.1.
- New Section R610.3.4 - Adds thermal barrier requirements from the HUD document into Section R610. These requirements are in line with the requirements of IRC Section R316.4.
- Section R610.4.1 – The inspection and labeling requirements have been specified in ANSI/APA PRS 610.1, this section deleted.
- Sections R610.5.3 and R610.5.4 - Moved from current location in Section R610.8 and R610.9 respectively to proposed location. This puts all of the connection details in one place. No technical changes made.
- Section R610.5.5 – Renumbered wall bracing provisions to accommodate proposed new locations for R610.5.3 and R610.5.4. Also added reference to bracing method CS-WSP to clarify bracing equivalence.
- Section R610.8 – Renumbered section and referenced tables and sections. No technical changes. Added a requirement that the strong axis of the header facers shall be placed in a horizontal orientation.
- Table R610.8 – Renumbered table and added clarifying language and additional footnotes to simplify use of the table. Corrected deflection criteria in footnotes.
- Figure R610.5(1) – Added reference to bottom wall connection for clarity.
- Figure R610.5(2) – Added reference to bottom wall connection for clarity. Clarified foundation annotation and corrected "FIRST STORY" annotation.
- Figure R610.5(3) – Removed gusset plate and reference. Modified callout for roof framing to include trusses and conventional roof framing. Added roof sheathing callout. Added cap-plate-to-top-plate connection requirement. Made adjustments to arrow heads to more clearly identify referenced portion.
- Figure R610.5(4) – Added "SIP Wall" callout to first story wall, and added an additional "Continuous Sealant" arrow at upper wall. Made adjustments to arrow heads to more clearly identify referenced portion.
- Figure R610.5(5) – Some editorial changes were made to callouts, arrow heads repositioned slightly to better indicate referenced portions. Title of figure changed to more accurately reflect figure.
- Figure R610.5.1 – Footnote 4 was removed as it is a duplicate of the requirements in the text. "TOP PLATE" arrow moved to better identify recessed top plate.
- Figure R610.5.2 – Sealant added and referenced in new figure. Capillary break more clearly shown and anchor bolt requirement deleted and reference to Section R403.1.6 added.
- Figure R610.5.8 – Sealant was added to figure and a minimum splice plate size was provided. The figure title was changed to better describe figure and the term "connection" was removed from the figure sub-headings.
- Figure R610.5.9 – Additional arrows were added to the "Continuous Sealant" callout.

All figures have been redrawn and reformatted to provide a cleaner, more easily understood IRC.

Note that many of the changes requested above were placed before the committee last cycle. Some concerns about the minimum foam requirements were raised by the foam industry and subsequently the whole change was denied. The foam requirements as well as the material requirements for the wood structural panel and adhesive have all been included in the national consensus-based ANSI/APA PRS 610.1 standard. Just the editorial/clarification portions of the original proposal remain in this proposal.

We encourage the code body to accept this code change proposal providing requisite clarity.

Cost Impact: Will not increase the cost of construction

This proposal reorganizes the existing provisions, corrects typo errors in text and figures, and recognizes new consensus standards.

Public Hearing Results

Committee Action:

Approved as Modified

Modify as follows:

R610.3.1 Core. The core material shall be composed of foam plastic insulation meeting one of the following requirements:

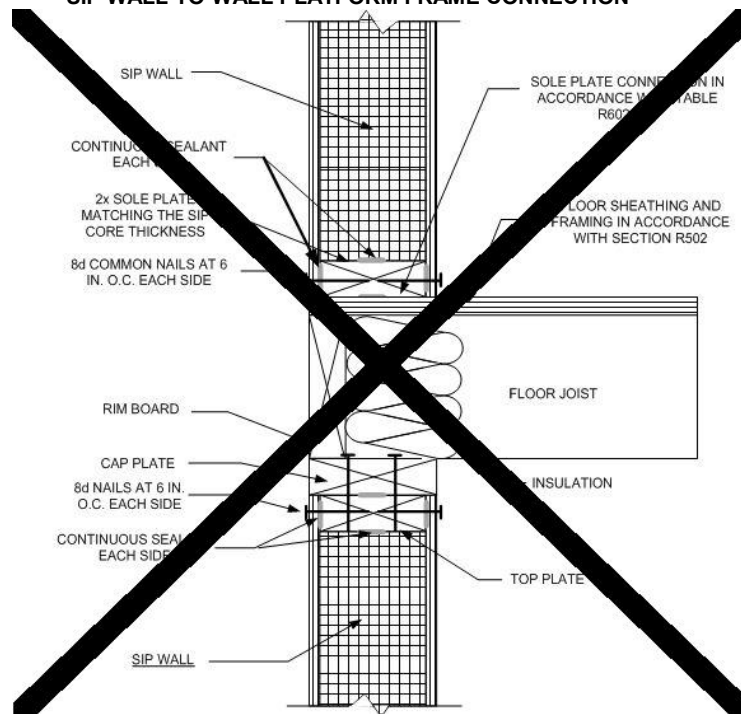
1. ASTM C 578 and have a minimum density of 0.90 pounds per cubic feet (14.4 kg/m³).
2. Polyurethane meeting the physical properties shown in Table R610.3.1.
3. An approved alternative.

All cores shall meet the requirements of Section R316.

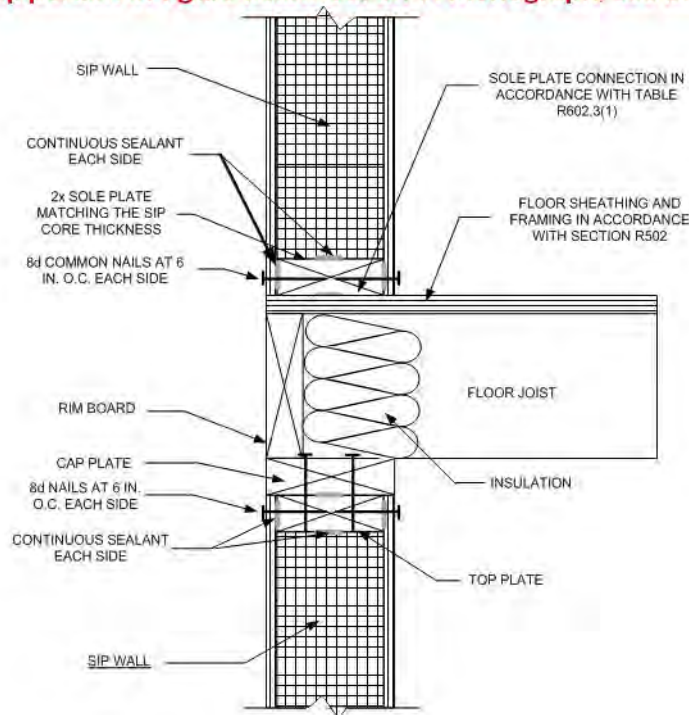
R610.5 Wall construction. Exterior walls of SIP construction shall be designed and constructed in accordance with the provisions of this section and Tables R610.5(1) and R610.5(2) and Figures R610.5(1) through R610.5(5). SIP walls shall be fastened to other wood building components in accordance with Tables R602.3(1) through R602.3(4).

Framing shall be attached in accordance with Table R602.3(1) unless otherwise provided for in Section R610.

**FIGURE R610.5 (4)
SIP WALL-TO-WALL PLATFORM FRAME CONNECTION**



(Top portion of figure below cut-off in monograph, see below)



For SI: 1 inch = 25.4 mm.

Note : Figures illustrate SIP-specific attachment requirements. Other connections shall be made in accordance with Tables R602.3(1) and (2), as appropriate.

R610.5.1 Top plate connection. SIP walls shall be capped with a double top plate installed to provide overlapping at corner, intersections and splines in accordance with Figure R610.5.1. The double top plates shall be made up of a single 2 by top plate having a width equal to the width of the panel core, and shall be recessed into the SIP below. Over this top plate a cap plate shall be placed. The cap plate width shall match the SIP thickness and overlap the facers on both sides of the panel. End joints in top plates shall be offset not less than 24 inches (610 mm).

R610.5.2 Bottom (sole) plate connection. SIP walls shall have full bearing on a sole plate having a width equal to the nominal width of the foam core. Where SIP walls are supported directly on continuous foundations, the wall wood sill plate shall be anchored to the foundation in accordance with Figure R610.5.2 and Section R403.1.

R610.6 Interior load-bearing walls. Interior load-bearing walls shall be constructed as specified for exterior walls.

R610.7 Drilling and notching. The maximum vertical chase penetration in SIPs shall have a maximum side dimension of 2 inches (51 mm) centered in the panel. Vertical chases shall have a minimum spacing of 24 inches (610 mm) on center. A maximum of two horizontal chases shall be permitted in each wall panel—one at 14 inches (360 mm) plus or minus 2 inches (51 mm) from the bottom of the panel and one at 48 inches (1220 mm) plus or minus 2 inches (51 mm) from the bottom edge of the SIPs panel. Additional penetrations are permitted where justified by analysis.

R610.10.1 Wood structural panel box headers. Wood structural panel box headers shall be allowed where SIP headers are not applicable. Wood structural panel box headers shall be constructed in accordance with Figure R602.7.3 and Table R602.7.3.

Committee Reason: The committee approved the proposal based on the proponents published reason statement. The proposal adds a new standard and clarifies and cleans up several sections of the SIPS requirements. The modification corrects several errors that occurred during the proposal submittal process.

Assembly Action:

None

Report of Committee Action Hearings
--

Public Comment 1:

Edward Keith, representing APA- The Engineered Wood Association (ed.keith@apawood.org); Borjen Yeh (borjen.yeh@apawood.org) requests Approve as Modified by this Public Comment.

Further modify as follows:

R610.3 Materials. SIPs shall comply with the ~~following criteria:~~ requirements of ANSI/APA PRS 610.1.

Commenter's Reason: This Public Comment addresses Sections R610.3. Section R610.3 was inadvertently left out of the monograph. It references the new ANSI/APA standard for SIPs panels and is the justification for the removal of the core, facers, and adhesives tables from the code as these are covered in the standard. We are asking the code body to approve the editorial change R610.3 and ask for a vote of Approved as modified by the Public Comment.

Final Action Results

RB217-16**AMPC1**

[←BACK](#)

[←BACK](#)

Code Change No: **S243-16 Part II**

Original Proposal

Section: IRC: R606.2.3

Proponent: Phillip Samblanet, representing The Masonry Society

THIS IS A 2 PART CODE CHANGE. PART I WILL BE HEARD BY THE IBC-STRUCTURAL CODE COMMITTEE. PART II WILL BE HEARD BY THE IRC-BUILDING CODE COMMITTEE. SEE THE TENTATIVE HEARING ORDERS FOR THESE COMMITTEES.

Revise as follows:

R606.2.3 AAC masonry. AAC masonry units shall conform to ASTM C1691 and ASTM C1693 for the strength class specified.

Reference standards type: This contains both new and updated standards

Add new standard(s) as follows:

ASTM C1386

ASTM C1691- 11 Standard Specification for Unreinforced Autoclaved Aerated Concrete (AAC) Masonry Units

ASTM C1693-11 Standard Specification for Autoclaved Aerated Concrete (AAC)

Reason: The definition is not needed and is incorrect. ASTM C1386 was withdrawn by ASTM in 2013, and AAC is now manufactured to different ASTM standards (ASTM C1691 for AAC masonry and ASTM C1693 for AAC in general). In addition, IBC Section 202 already contains a definition for AAC Masonry, which is both more appropriate and correct. While this definition could apply AAC as used in conjunction with Chapter 19, that Chapter does not address AAC. Deleting the definition of Autoclaved Aerated Concrete thus removes the reference to an ASTM standard no longer used, and it cleans up the IBC as a whole. Part II updates references to it in the IRC. .

Cost Impact: Will not increase the cost of construction

Revision of this section does not impact the cost of construction. The definition is not needed, and the referenced standard has been withdrawn. The change merely eliminates this error in the IBC

Analysis: A review of the standard(s) proposed for inclusion in the code, ASTM C1691 & ASTM C1693, with regard to the ICC criteria for referenced standards (Section 3.6 of CP#28) will be posted on the ICC website on or before April 1, 2016.

Report of Committee Action Hearings

Committee Action:

Approved as Submitted

Committee Reason: This proposal updates the standard for autoclaved aerated concrete by deleting a withdrawn standard and adding two new standards for this product.

Assembly Action

None

Final Action Results

S243-16 Part II

AS

Code Change No: **RB218-16**

Original Proposal

Section: R602.3(6) (New), R602.3.1

Proponent: Gary Ehrlich, National Association of Home Builders, representing National Association of Home Builders (gehrlich@nahb.org)

Revise as follow:

R602.3.1 Stud size, height and spacing. The size, height and spacing of studs shall be in accordance with Table R602.3(5).

Exceptions:

1. Utility grade studs shall not be spaced more than 16 inches (406 mm) on center, shall not support more than a roof and ceiling, and shall not exceed 8 feet (2438 mm) in height for exterior walls and load-bearing walls or 10 feet (3048 mm) for interior nonload-bearing walls.
2. Where snow loads are less than or equal to 25 pounds per square foot (1.2 kPa), and the ultimate design wind speed is less than or equal to 130 mph (58.1 m/s), 2-inch by 6-inch (38 mm by 14 mm) studs supporting a roof load with not more than 6 feet (1829 mm) of tributary length shall have a maximum height of 18 feet (5486 mm) where spaced at 16 inches (406 mm) on center, or 20 feet (6096 mm) where spaced at 12 inches (304.8 mm) on center. Studs shall be minimum No. 2 grade lumber.
3. Exterior load-bearing studs not exceeding 12 feet (3658 mm) in height provided in accordance with Table R602.3(6). The minimum number of full-height studs adjacent to openings shall be in accordance with Section R602.7.5. The building shall be located in Exposure B, the roof live load shall not exceed 20 psf (0.96 kPa), and the ground snow load shall not exceed 30 psf (1.4 kPa). Studs and plates shall be #2 grade lumber or better.

Add new table as follows:

TABLE R602.3(6)
ALTERNATE WOOD BEARING WALL STUD SIZE, HEIGHT AND SPACING

Stud Height	Supporting	Stud Spacing ^a	Ultimate Design Wind Speed					
			115 mph		130 mph ^b		140 mph ^b	
			Roof/Floor Span		Roof/Floor Span		Roof/Floor Span	
			12 ft.	24 ft.	12 ft.	24 ft.	12 ft.	24 ft.
11 ft.	Roof Only	12 in.	2x4	2x4	2x4	2x4	2x4	2x4
		16 in.	2x4	2x4	2x4	2x6	2x4	2x6
		24 in.	2x6	2x6	2x6	2x6	2x6	2x6
	Roof and One Floor	12 in.	2x4	2x6	2x4	2x6	2x4	2x6
		16 in.	2x6	2x6	2x6	2x6	2x6	2x6
		24 in.	2x6	2x6	2x6	2x6	2x6	2x6
12 ft.	Roof Only	12 in.	2x4	2x4	2x4	2x6	2x4	2x6
		16 in.	2x4	2x6	2x6	2x6	2x6	2x6
		24 in.	2x6	2x6	2x6	2x6	2x6	2x6
	Roof and One Floor	12 in.	2x4	2x6	2x6	2x6	2x6	2x6
		16 in.	2x6	2x6	2x6	2x6	2x6	2x6
		24 in.	2x6	2x6	2x6	2x6	2x6	2x6

		16 in.	2x6	2x6	2x6	2x6	2x6	2x6
		24 in.	2x6	2x6	2x6	2x6	2x6	DR

For SI: 1 inch = 25.4mm, 1 foot = 304.8 mm, 1 mph = 0.447 m/s

DR = Design Required

- a. Wall studs not exceeding 16 in. on center shall be sheathed with minimum 1/2" (12/7 mm) gypsum board on the interior and 3/8" (9 mm) wood structural panel sheathing on the exterior. Wood structural panel sheathing shall be attached with 8d (2.5" x 0.131") nails spaced a maximum of 6" on center along panel edges and 12" on center at intermediate supports, and all panel joints shall occur over studs or blocking.
- b. Where the ultimate design wind speed exceeds 115 mph, studs shall be attached to top and bottom plates with connectors having a minimum 300 pound (136 kg) capacity.

Reason: The purpose of this code change is to introduce a new table for load-bearing studs over 10 feet in height but not exceeding 12 feet in height. Previous to the 2015 edition, the IRC provided Table R602.3.1 allowing exterior load-bearing studs up to 20 feet in height for a limited set of conditions. In the 2015 IRC, the table was removed and converted into Exception #2 under Section R602.3.1.

One of the main reasons the table was removed was that builders and building officials did not understand where the table applied based on the limitations. Also, the allowable stud sizes in the table dated back to the CABO code, when there were actually three tables which were subsequently combined into Table R602.3.1 in the 2000 IRC. No technical substantiation for the allowable stud sizes in the old table could be located.

This table was constructed using the exterior wall stud bending stresses and exterior wall stud compression stresses from Tables 2.9A and 2.9B of the 2012 *Wood Frame Construction Manual*. Combined bending and axial load calculations in accordance with Section 3.9 of the 2012 AWC *National Design Specification for Wood Construction*. Bearing perpendicular to grain was checked for top and bottom plates per Section 3.10.2 of the NDS. Connection capacities from Table R602.3(1) were checked against the connection loads from Table 2.1 of the WFCM.

This new table provides additional flexibility beyond the old Table R602.3.1 and Exception #2 under Section R602.3.1 which replaced it. The new table covers framing spans of both 12 feet and 24 feet. In addition to 2-story foyers, small great rooms and gable end conditions, the new table would also apply to conditions such as an attached garage where studs over 10 feet may be required due to a sloped site or where additional headroom for a van may be desired. The table also works for a somewhat higher ground snow load (30 psf versus 25 psf) and in all areas outside the region where wind design is required per Figure R301.2(4)B. The table can also be used for walls with large openings, provided the number of additional king studs required by Section R602.7.5 are furnished on each side of the openings.

Cost Impact: Will not increase the cost of construction

The code change will actually save builders the cost of hiring an engineer to design the portion of the building falling outside the limits of Table R602.3(5) or Exception #2 of Section R602.3.1. The minimum cost to retain an engineer to design the limited area of tall studs is estimated to be \$400 to \$800. The code change will also allow 2x4 studs to be used in cases where 2x6 studs would have been needed previously, for a modest savings in material costs (about \$3-4 per stud).

Report of Committee Action Hearings

Committee Action:

Approved as Modified

Modify as follows:

**TABLE R602.3(6)
ALTERNATE WOOD BEARING WALL STUD SIZE, HEIGHT AND SPACING**

Stud Height	Supporting	Stud Spacing ^a	Ultimate Design Wind Speed					
			115 mph		130 mph ^b		140 mph ^b	
			<u>Maximum Roof/Floor Span</u>		<u>Maximum Roof/Floor Span</u>		<u>Maximum Roof/Floor Span</u>	
			12 ft.	24 ft.	12 ft.	24 ft.	12 ft.	24 ft.
11 ft.	Roof Only	12 in.	2x4	2x4	2x4	2x4	2x4	2x4
		16 in.	2x4	2x4	2x4	2x6	2x4	2x6
		24 in.	2x6	2x6	2x6	2x6	2x6	2x6

Stud Height	Supporting	Stud Spacing ^a	Ultimate Design Wind Speed					
			115 mph		130 mph ^b		140 mph ^b	
			<u>Maximum</u> Roof/Floor Span		<u>Maximum</u> Roof/Floor Span		<u>Maximum</u> Roof/Floor Span	
			12 ft.	24 ft.	12 ft.	24 ft.	12 ft.	24 ft.
	Roof and One Floor	12 in.	2x4	2x6	2x4	2x6	2x4	2x6
		16 in.	2x6	2x6	2x6	2x6	2x6	2x6
		24 in.	2x6	2x6	2x6	2x6	2x6	2x6
12 ft.	Roof Only	12 in.	2x4	2x4	2x4	2x6	2x4	2x6
		16 in.	2x4	2x6	2x6	2x6	2x6	2x6
		24 in.	2x6	2x6	2x6	2x6	2x6	2x6
	Roof and One Floor	12 in.	2x4	2x6	2x6	2x6	2x6	2x6
		16 in.	2x6	2x6	2x6	2x6	2x6	2x6
		24 in.	2x6	2x6	2x6	2x6	2x6	DR

For SI: 1 inch = 25.4mm, 1 foot = 304.8 mm, 1 mph = 0.447 m/s

DR = Design Required

- Wall studs not exceeding 16 in. on center shall be sheathed with minimum 1/2" (12/7 mm) gypsum board on the interior and 3/8" (9 mm) wood structural panel sheathing on the exterior. Wood structural panel sheathing shall be attached with 8d (2.5" x 0.131") nails spaced a maximum of 6" on center along panel edges and 12" on center at intermediate supports, and all panel joints shall occur over studs or blocking.
- Where the ultimate design wind speed exceeds 115 mph, studs shall be attached to top and bottom plates with connectors having a minimum 300 pound (136 kg) lateral capacity
- The maximum span is applicable to both simple- and multiple-span roof and floor conditions. The roof assembly shall not contain a habitable attic.

Committee Reason: The committee approved the proposal based on the proponents published reason statement. This provides improvement to the code by moving confusing requirements from the exception into a table. Also, it allows more flexibility as regards two stories. The modifications adds the term maximum to the headings for clarity and provides a footnote that adds clarification for the load condition used for the table,

Assembly Action

None

Final Action Results

RB218-16

AM

Code Change No: **RB219-16**

Original Proposal

Section: R602.10.3, R602.3

Proponent: Paul Coats, PE CBO, American Wood Council, representing American Wood Council (pcoats@awc.org)

Revise as follows:

**TABLE R602.3(1)
FASTENING SCHEDULE**

ITEM	DESCRIPTION OF BUILDING ELEMENTS	NUMBER AND TYPE OF FASTENER ^{a, b, c}	SPACING AND LOCATION
Roof			
1	Blocking between ceiling joists or rafters to top plate	4-8d box (2 ¹ / ₂ " × 0.113") or 3-8d common (2 ¹ / ₂ " × 0.131"); or 3-10d box (3" × 0.128"); or 3-3" × 0.131" nails	Toe nail
2	Ceiling joists to top plate	4-8d box (2 ¹ / ₂ " × 0.113"); or 3-8d common (2 ¹ / ₂ " × 0.131"); or 3-10d box (3" × 0.128"); or 3-3" × 0.131" nails	Per joist, toe nail
3	Ceiling joist not attached to parallel rafter, laps over partitions [see Sections R802.3.1, R802.3.2 and Table R802.5.1(9)]	4-10d box (3" × 0.128"); or 3-16d common (3 ¹ / ₂ " × 0.162"); or 4-3" × 0.131" nails	Face nail
4	Ceiling joist attached to parallel rafter (heel joint) [see Sections R802.3.1 and R802.3.2 and Table R802.5.1(9)]	Table R802.5.1(9)	Face nail
5	Collar tie to rafter, face nail or 1 ¹ / ₄ " × 20 ga. ridge strap to rafter	4-10d box (3" × 0.128"); or 3-10d common (3" × 0.148"); or	Face nail each rafter

		4-3" × 0.131" nails	
6	Rafter or roof truss to plate	3-16d box nails (3 ¹ / ₂ " × 0.135"); or 3-10d common nails (3" × 0.148"); or 4-10d box (3" × 0.128"); or 4-3" × 0.131" nails	2 toe nails on one side and 1 toe nail on opposite side of each rafter or truss ¹
7	Roof rafters to ridge, valley or hip rafters or roof rafter to minimum 2" ridge beam	4-16d (3 ¹ / ₂ " × 0.135"); or 3-10d common (3 ¹ / ₂ " × 0.148"); or 4-10d box (3" × 0.128"); or 4-3" × 0.131" nails	Toe nail
		3-16d box 3 ¹ / ₂ " × 0.135"); or 2-16d common (3 ¹ / ₂ " × 0.162"); or 3-10d box (3" × 0.128"); or 3-3" × 0.131" nails	End nail
Wall			
8	Stud to stud (not at braced wall panels)	16d common (3 ¹ / ₂ " × 0.162")	24" o.c. face nail
		10d box (3" × 0.128"); or 3" × 0.131" nails	16" o.c. face nail
9	Stud to stud and abutting studs at intersecting wall corners (at braced wall panels)	16d box (3 ¹ / ₂ " × 0.135"); or 3" × 0.131" nails	12" o.c. face nail
		16d common (3 ¹ / ₂ " × 0.162")	16" o.c. face nail
10	Built-up header (2" to 2" header with ¹ / ₂ " spacer)	16d common (3 ¹ / ₂ " × 0.162")	16" o.c. each edge face nail
		16d box (3 ¹ / ₂ " × 0.135")	12" o.c. each edge face nail
11	Continuous header to stud	5-8d box (2 ¹ / ₂ " × 0.113"); or 4-8d common (2 ¹ / ₂ " × 0.131"); or 4-10d box (3" × 0.128")	Toe nail

12	Top plate to top plate	16d common ($3\frac{1}{2}" \times 0.162"$)	16" o.c. face nail
		10d box ($3" \times 0.128"$); or $3" \times 0.131"$ nails	12" o.c. face nail
13	Double top plate splice for SDCs A-D₂ with seismic braced wall line spacing < 25'	8-16d common ($3\frac{1}{2}" \times 0.162"$); or 12-16d box ($3\frac{1}{2}" \times 0.135"$); or 12-10d box ($3" \times 0.128"$); or 12- $3" \times 0.131"$ nails	Face nail on each side of end joint (minimum 24" lap splice length each side of end joint)
	Double top plate splice SDCs D₀, D₁, or D₂; and braced wall line spacing ≥ 25'	12-16d ($3\frac{1}{2}" \times 0.135"$)	
14	Bottom plate to joist, rim joist, band joist or blocking (not at braced wall panels)	16d common ($3\frac{1}{2}" \times 0.162"$)	16" o.c. face nail
		16d box ($3\frac{1}{2}" \times 0.135"$); or $3" \times 0.131"$ nails	12" o.c. face nail
15	Bottom plate to joist, rim joist, band joist or blocking (at braced wall panel)	3-16d box ($3\frac{1}{2}" \times 0.135"$); or 2-16d common ($3\frac{1}{2}" \times 0.162"$); or 4- $3" \times 0.131"$ nails	3 each 16" o.c. face nail 2 each 16" o.c. face nail 4 each 16" o.c. face nail
16	Top or bottom plate to stud	4-8d box ($2\frac{1}{2}" \times 0.113"$); or 3-16d box ($3\frac{1}{2}" \times 0.135"$); or 4-8d common ($2\frac{1}{2}" \times 0.131"$); or 4-10d box ($3" \times 0.128"$); or 4- $3" \times 0.131"$ nails	Toe nail
		3-16d box ($3\frac{1}{2}" \times 0.135"$); or 2-16d common ($3\frac{1}{2}" \times 0.162"$); or 3-10d box ($3" \times 0.128"$); or 3- $3" \times 0.131"$ nails	End nail
17	Top plates, laps at corners and intersections	3-10d box ($3" \times 0.128"$); or 2-16d common ($3\frac{1}{2}" \times 0.162"$); or 3- $3" \times 0.131"$ nails	Face nail
18	1" brace to each stud and plate	3-8d box ($2\frac{1}{2}" \times 0.113"$); or 2-8d common ($2\frac{1}{2}" \times 0.131"$); or 2-10d box ($3" \times 0.128"$); or 2-	Face nail

		staples 1 ³ / ₄ "	
19	1" × 6" sheathing to each bearing	3-8d box (2 ¹ / ₂ " × 0.113"); or2-8d common (2 ¹ / ₂ " × 0.131"); or2-10d box (3" × 0.128"); or2 staples, 1" crown, 16 ga., 1 ³ / ₄ " long	Face nail
20	1" × 8" and wider sheathing to each bearing	3-8d box (2 ¹ / ₂ " × 0.113"); or3-8d common (2 ¹ / ₂ " × 0.131"); or3-10d box (3" × 0.128"); or3 staples, 1" crown, 16 ga., 1 ³ / ₄ "long	Face nail
		Wider than 1" × 8"4-8d box (2 ¹ / ₂ " × 0.113"); or3-8d common (2 ¹ / ₂ " × 0.131"); or3-10d box (3" × 0.128"); or4 staples, 1" crown, 16 ga., 1 ³ / ₄ " long	
Floor			
21	Joist to sill, top plate or girder	4-8d box (2 ¹ / ₂ " × 0.113"); or3-8d common (2 ¹ / ₂ " × 0.131"); or3-10d box (3" × 0.128"); or3-3" × 0.131" nails	Toe nail
22	Rim joist, band joist or blocking to sill or top plate (roof applications also)	8d box (2 ¹ / ₂ " × 0.113")	4" o.c. toe nail
		8d common (2 ¹ / ₂ " × 0.131"); or10d box (3" × 0.128"); or3" × 0.131" nails	6" o.c. toe nail
23	1" × 6" subfloor or less to each joist	3-8d box (2 ¹ / ₂ " × 0.113"); or2-8d common (2 ¹ / ₂ " × 0.131"); or3-10d box (3" × 0.128"); or2 staples, 1" crown, 16 ga., 1 ³ / ₄ " long	Face nail
Floor			

24	2" subfloor to joist or girder	3-16d box (3 ¹ / ₂ " × 0.135"); or 2-16d common (3 ¹ / ₂ " × 0.162")	Blind and face nail	
25	2" planks (plank & beam—floor & roof)	3-16d box (3 ¹ / ₂ " × 0.135"); or 2-16d common (3 ¹ / ₂ " × 0.162")	At each bearing, face nail	
26	B and or rim joist to joist	3-16d common (3 ¹ / ₂ " × 0.162"); 4-10 box (3" × 0.128"), or 4-3" × 0.131" nails; or 4-3" × 14 ga. staples, ⁷ / ₁₆ " crown	End nail	
27	Built-up girders and beams, 2-inch lumber layers	20d common (4" × 0.192"); or	Nail each layer as follows: 32" o.c. at top and bottom and staggered.	
		10d box (3" × 0.128"); or 3" × 0.131" nails	24" o.c. face nail at top and bottom staggered on opposite sides	
		And: 2-20d common (4" × 0.192"); or 3-10d box (3" × 0.128"); or 3-3" × 0.131" nails	Face nail at ends and at each splice	
28	Ledger strip supporting joists or rafters	4-16d box (3 ¹ / ₂ " × 0.135"); or 3-16d common (3 ¹ / ₂ " × 0.162"); or 4-10d box (3" × 0.128"); or 4-3" × 0.131" nails	At each joist or rafter, face nail	
29	Bridging <u>or blocking</u> to joist	2-10d <u>box</u> (3" × 0.128"), <u>or</u> 2-8d <u>common</u> (2-1/2" × 0.131"); <u>or</u> 2-3" × 0.131" nails	Each end, toe nail	
ITEM	DESCRIPTION OF BUILDING ELEMENTS	NUMBER AND TYPE OF FASTENER ^{a, b, c}	SPACING OF FASTENERS	
			Edges (inches) ^h	Intermediate supports ^e (inches)
Wood structural panels, subfloor, roof and interior wall sheathing to framing and particleboard wall sheathing to framing [see Table R602.3(3) for wood structural panel exterior wall sheathing to wall framing]				




30	$\frac{3}{8}$ " - $\frac{1}{2}$ "	6d common (2" × 0.113") nail (subfloor, wall) ¹ 8d common ($2\frac{1}{2}$ " × 0.131") nail (roof)	6	12 ^f
31	$\frac{19}{32}$ " - 1"	8d common nail ($2\frac{1}{2}$ " × 0.131")	6	12 ^f
32	$1\frac{1}{8}$ " - $1\frac{1}{4}$ "	10d common (3" × 0.148") nail; or 8d ($2\frac{1}{2}$ " × 0.131") deformed nail	6	12
Other wall sheathing⁹				
33	$\frac{1}{2}$ " structural cellulosic fiberboardsheathing	$1\frac{1}{2}$ " galvanized roofing nail, $\frac{7}{16}$ " head diameter, or <u>4" crown staple 16 ga., $1\frac{1}{4}$" long 16 ga. staple with $\frac{7}{16}$" or 1" crown</u>	3	6
34	$\frac{25}{32}$ " structural cellulosic fiberboard sheathing	$1\frac{3}{4}$ " galvanized roofing nail, $\frac{7}{16}$ " head diameter, or <u>4" crown staple 16 ga., $1\frac{1}{4}$" long 1-1/2" long 16 ga. staple with $\frac{7}{16}$" or 1" crown</u>	3	6
35	$\frac{1}{2}$ " gypsum sheathing ^d	$1\frac{1}{2}$ " galvanized roofing nail; staple galvanized, $1\frac{1}{2}$ " long; $1\frac{1}{4}$ " screws, Type W or S	7	7
36	$\frac{5}{8}$ " gypsum sheathing ^d	$1\frac{3}{4}$ " galvanized roofing nail; staple galvanized, $1\frac{5}{8}$ " long; $1\frac{5}{8}$ " screws, Type W or S	7	7
Wood structural panels, combination subfloor underlayment to framing				
37	$\frac{3}{4}$ " and less	6d deformed (2" × 0.120") nail; or 8d common ($2\frac{1}{2}$ " × 0.131") nail	6	12
38	$\frac{7}{8}$ " - 1"	8d common ($2\frac{1}{2}$ " × 0.131") nail; or 8d deformed ($2\frac{1}{2}$ " × 0.120") nail	6	12

39	1 ¹ / ₈ " - 1 ¹ / ₄ "	10d common (3" × 0.148") nail; or 8d deformed (2 ¹ / ₂ " × 0.120") nail	6	12
----	---	---	---	----

For SI: 1 inch = 25.4 mm, 1 foot = 304.8 mm, 1 mile per hour = 0.447 m/s; 1 ksi = 6.895 MPa.

- a. Nails are smooth-common, box or deformed shanks except where otherwise stated. Nails used for framing and sheathing connections shall have minimum average bending yield strengths as shown: 80 ksi for shank diameter of 0.192 inch (20d common nail), 90 ksi for shank diameters larger than 0.142 inch but not larger than 0.177 inch, and 100 ksi for shank diameters of 0.142 inch or less.
- b. Staples are 16 gage wire and have a minimum ⁷/₁₆-inch on diameter crown width.
- c. Nails shall be spaced at not more than 6 inches on center at all supports where spans are 48 inches or greater.
- d. Four-foot by 8-foot or 4-foot by 9-foot panels shall be applied vertically.
- e. Spacing of fasteners not included in this table shall be based on Table R602.3(2).
- f. Where the ultimate design wind speed is 130 mph or less, nails for attaching wood structural panel roof sheathing to gable end wall framing shall be spaced 6 inches on center. Where the ultimate design wind speed is greater than 130 mph, nails for attaching panel roof sheathing to intermediate supports shall be spaced 6 inches on center for minimum 48-inch distance from ridges, eaves and gable end walls; and 4 inches on center to gable end wall framing.
- g. Gypsum sheathing shall conform to ASTM C 1396 and shall be installed in accordance with GA 253. Fiberboard sheathing shall conform to ASTM C 208.
- h. Spacing of fasteners on floor sheathing panel edges applies to panel edges supported by framing members and required blocking and at floor perimeters only. Spacing of fasteners on roof sheathing panel edges applies to panel edges supported by framing members and required blocking. Blocking of roof or floor sheathing panel edges perpendicular to the framing members need not be provided except as required by other provisions of this code. Floor perimeter shall be supported by framing members or solid blocking.
- i. Where a rafter is fastened to an adjacent parallel ceiling joist in accordance with this schedule, provide two toe nails on one side of the rafter and toe nails from the ceiling joist to top plate in accordance with this schedule. The toe nail on the opposite side of the rafter shall not be required.

TABLE R602.10.3 (4)
SEISMIC ADJUSTMENT FACTORS TO THE REQUIRED LENGTH OF WALL BRACING

ITEM NUMBER	ADJUSTMENT BASED ON:	STORY	CONDITION	ADJUSTMENT FACTOR ^{a, b} [Multiply length from Table R602.10.3(3) by this factor]	APPLICABLE METHODS
1	Story height (Section 301.3)	Any story	≤ 10 feet	1.0	All methods
			> 10 feet and ≤ 12 feet	1.2	
2	Braced wall line spacing, townhouses in SDC C	Any story	≤ 35 feet	1.0	
			> 35 feet and ≤ 50 feet	1.43	
3	Braced wall line spacing, in SDC D ₀ , D ₁ , D ₂ ^c	Any story	> 25 feet and ≤ 30 feet	1.2	
			> 30 feet and ≤ 35 feet	1.4	
4	Wall dead load	Any story	> 8 psf and < 15 psf	1.0	
			< 8 psf	0.85	
5	Roof/ceiling dead load for wall supporting	1-, 2- or 3-story building	≤ 15 psf	1.0	
		2- or 3-story building	> 15 psf and ≤ 25 psf	1.1	
		1-story building	> 15 psf and ≤ 25 psf	1.2	
6	Walls with stone or masonry veneer, townhouses in SDC C ^{d, e}		1.0	All methods	
			1.5		
			1.5		
7	Walls with stone or masonry veneer, detached one- and two-family dwellings in SDC D ₀ – D ₂ ^{d, f}	Any story	See Table R602.10.6.5	BV-WSP	
8	Interior gypsum board finish (or equivalent)	Any story	Omitted from inside face of braced wall panels	1.5	DWB, WSP, SFB, PBS, PCP, HPS, CS-WSP, CS-G, CS-SFB

For SI: 1 foot = 304.8 mm, 1 pound per square foot = 0.0479 kPa.

- Linear interpolation shall be permitted.
- The total length of bracing required for a given wall line is the product of all applicable adjustment factors.
- The length-to-width ratio for the floor/roof *diaphragm* shall not exceed 3:1. ~~The top plate lap splice nailing shall be in accordance with Table R602.3(1), Item 13.~~
- Applies to stone or masonry veneer exceeding the first story height.
- The adjustment factor for stone or masonry veneer shall be applied to all exterior *braced wall lines* and all *braced wall lines* on the interior of the building, backing or perpendicular to and laterally supported veneered walls.
- See Section R602.10.6.5 for requirements where stone or masonry veneer does not exceed the first-story height.

Reason: ITEM 7: The correct length of the 10d common nail is 3", not 3-1/2". 10d common is correctly shown as 3" long elsewhere in the table. This is considered to be an editorial change as a 10d common nail is 3" long per ASTM F1667 and correctly shown as 3" long elsewhere in the table.

ITEM 13: Multiple changes to the top plate splice nailing were approved in the previous code change cycle. One change, RB272-13, increased the nailing of the top plate splice to bring it in line with the 2015 IBC as well as to include nailing schedules that are of roughly equivalent lateral resistance. A second change, RB274-13, specified increased top plate splice nailing only for higher SDCs and where braced wall line spacing is greater than 25'. The combination of both proposals produced line 13 of the 2015 IRC in which the same double top plate splice nailing is shown for wall line spacing <25' and ≥25' (i.e. 12-16d (3-1/2" x 0.135" box nails). To simplify presentation of the top plate nailing schedule to the singular nailing pattern intended by RB272-13, it is proposed to delete language associated with triggering different nailing based on SDC or wall line spacing. The special reference from footnote c of Table R602.10.3(4) that addresses applicable top plate nailing is also no longer necessary with the proposed revision to a single nail schedule and is proposed to be deleted. Related: prior cycle RB272-13, RB274-13, Rb278-13.

ITEM 23: The equivalent nailing to the 8d common case is (2) 10d box versus (3) 10d box. 2 nails is consistent with item 24 in IBC Table 2304.10.1.

ITEM 29: The "bridging to joist" case was added during the previous code change cycle but included only the 10d (3" x 0.128") nail option. The 10d is clarified as a box nail size in this change. Other equivalent nail options are added and "or blocking" is added to the description to pick up the commonly used term for the application being described.

ITEMS 33 and 34: 7/16" crown was inadvertently excluded from change proposal RB278-13 which reorganized the fastening table to create a more consistent format between the IBC and IRC prescriptive fastening tables. This change restores the 7/16" crown. It also increases the staple length for 25/32" sheathing thickness which was previously proposed and approved (S75-06/07 Part II) but not picked up in publication.

REVISION TO FOOTNOTE c IN TABLE R602.10.3(4): See the explanation in Item 13 above, and the last sentence.

Cost Impact: Will not increase the cost of construction

Because these are mostly editorial corrections and correlations, it is not anticipated that the cost of construction will increase. For rows where the nailing changes slightly, current alternatives are also retained.

Report of Committee Action Hearings
--

Committee Action:

Approved as Submitted

Errata: In Table R602.10.3(4), at Item 6 under story, the icons are not deleted.

Committee Reason: The committee approved this proposal based on the proponents published reason statement.

Assembly Action:

None

Final Action Results

RB219-16

AS

Code Change No: **RB220-16**

Original Proposal

Section: R602.3

Proponent: Paul Coats, PE CBO, American Wood Council, representing American Wood Council (pcoats@awc.org)

Revise as follows:

**TABLE R602.3 (1)
FASTENING SCHEDULE**

ITEM	DESCRIPTION OF BUILDING ELEMENTS	NUMBER AND TYPE OF FASTENER ^{a, b, c}	SPACING AND LOCATION
Roof			
1	Blocking between ceiling joists or rafters to top plate	4-8d box (2 ¹ / ₂ " × 0.113") or 3-8d common (2 ¹ / ₂ " × 0.131"); or 3-10d box (3" × 0.128"); or 3-3" × 0.131" nails	Toe nail
2	Ceiling joists to top plate	4-8d box (2 ¹ / ₂ " × 0.113"); or 3-8d common (2 ¹ / ₂ " × 0.131"); or 3-10d box (3" × 0.128"); or 3-3" × 0.131" nails	Per joist, toe nail
3	Ceiling joist not attached to parallel rafter, laps over partitions [see Sections R802.3.1, R802.3.2 and Table R802.5.1(9)]	4-10d box (3" × 0.128"); or 3-16d common (3 ¹ / ₂ " × 0.162"); or 4-3" × 0.131" nails	Face nail
4	Ceiling joist attached to parallel rafter (heel joint) [see Sections R802.3.1 and R802.3.2 and Table R802.5.1(9)]	Table R802.5.1(9)	Face nail
5	Collar tie to rafter, face nail or 1 ¹ / ₄ " × 20 ga. ridge strap to rafter	4-10d box (3" × 0.128"); or 3-10d common (3" × 0.148"); or 4-3" × 0.131" nails	Face nail each rafter
6	Rafter or roof truss to plate	3-16d box nails (3 ¹ / ₂ " × 0.135"); or 3-10d common nails (3" × 0.148"); or 4-10d box (3" × 0.128"); or 4-3" × 0.131" nails	2 toe nails on one side and 1 toe nail on opposite side of each rafter or truss ⁱ
7	Roof rafters to ridge, valley or hip rafters or roof rafter to minimum 2" ridge beam	4-16d (3 ¹ / ₂ " × 0.135"); or 3-10d common (3 ¹ / ₂ " × 0.148"); or 4-10d box (3" × 0.128"); or 4-3" × 0.131" nails	Toe nail
		3-16d box 3 ¹ / ₂ " × 0.135"); or 2-16d common (3 ¹ / ₂ " × 0.162"); or 3-10d box (3" × 0.128"); or 3-3" × 0.131" nails	End nail
Wall			
8	Stud to stud (not at braced wall panels)	16d common (3 ¹ / ₂ " × 0.162")	24" o.c. face nail
		10d box (3" × 0.128"); or 3" × 0.131" nails	16" o.c. face nail
9	Stud to stud and abutting studs at intersecting wall corners	16d box (3 ¹ / ₂ " × 0.135"); or 3" × 0.131" nails	12" o.c. face nail

	(at braced wall panels)	16d common (3 ¹ / ₂ " × 0.162")	16" o.c. face nail
10	Built-up header (2" to 2" header with 1 ¹ / ₂ " spacer)	16d common (3 ¹ / ₂ " × 0.162")	16" o.c. each edge face nail
		16d box (3 ¹ / ₂ " × 0.135")	12" o.c. each edge face nail
11	Continuous header to stud	5-8d box (2 ¹ / ₂ " × 0.113"); or 4-8d common (2 ¹ / ₂ " × 0.131"); or 4-10d box (3" × 0.128")	Toe nail
12	Top plate to top plate	16d common (3 ¹ / ₂ " × 0.162")	16" o.c. face nail
		10d box (3" × 0.128"); or 3" × 0.131" nails	12" o.c. face nail
13	Double top plate splice for SDCs A-D2 with seismic braced wall line spacing	8-16d common (3 ¹ / ₂ " × 0.162"); or 12-16d box (3 ¹ / ₂ " × 0.135"); or 12-10d box (3" × 0.128"); or 12-3" × 0.131" nails	Face nail on each side of end joint (minimum 24" lap splice length each side of end joint)
	Double top plate splice SDCs D ₀ , D ₁ , or D ₂ ; and braced wall line spacing ≥ 25'	12-16d (3 ¹ / ₂ " × 0.135")	
14	Bottom plate to joist, rim joist, band joist or blocking (not at braced wall panels)	16d common (3 ¹ / ₂ " × 0.162")	16" o.c. face nail
		16d box (3 ¹ / ₂ " × 0.135"); or 3" × 0.131" nails	12" o.c. face nail
15	Bottom plate to joist, rim joist, band joist or blocking (at braced wall panel)	3-16d box (3 ¹ / ₂ " × 0.135"); or 2-16d common (3 ¹ / ₂ " × 0.162"); or 4-3" × 0.131" nails	3 each 16" o.c. face nail 2 each 16" o.c. face nail 4 each 16" o.c. face nail
16	Top or bottom plate to stud	4-8d box (2 ¹ / ₂ " × 0.113"); or 3-16d box (3 ¹ / ₂ " × 0.135"); or 4-8d common (2 ¹ / ₂ " × 0.131"); or 4-10d box (3" × 0.128"); or 4-3" × 0.131" nails	Toe nail
		3-16d box (3 ¹ / ₂ " × 0.135"); or 2-16d common (3 ¹ / ₂ " × 0.162"); or 3-10d box (3" × 0.128"); or 3-3" × 0.131" nails	End nail
17	Top plates, laps at corners and intersections	3-10d box (3" × 0.128"); or 2-16d common (3 ¹ / ₂ " × 0.162"); or 3-3" × 0.131" nails	Face nail
18	1" brace to each stud and plate	3-8d box (2 ¹ / ₂ " × 0.113"); or 2-8d common (2 ¹ / ₂ " × 0.131"); or 2-10d box (3" × 0.128"); or 2 staples 1 ³ / ₄ "	Face nail
19	1" × 6" sheathing to each bearing	3-8d box (2 ¹ / ₂ " × 0.113"); or 2-8d common (2 ¹ / ₂ " × 0.131"); or 2-10d box (3" × 0.128"); or 2 staples, 1" crown, 16 ga., 1 ³ / ₄ " long	Face nail
20	1" × 8" and wider sheathing to each bearing	3-8d box (2 ¹ / ₂ " × 0.113"); or 3-8d common (2 ¹ / ₂ " × 0.131"); or 3-10d box (3" × 0.128"); or 3 staples, 1" crown, 16 ga., 1 ³ / ₄ " long	Face nail
		Wider than 1" × 8" 4-8d box (2 ¹ / ₂ " × 0.113"); or 3-8d common (2 ¹ / ₂ " × 0.131"); or 3-10d box (3" × 0.128"); or 4 staples, 1" crown, 16 ga., 1 ³ / ₄ " long	
Floor			
21	Joist to sill, top plate or girder	4-8d box (2 ¹ / ₂ " × 0.113"); or 3-8d common (2 ¹ / ₂ " × 0.131"); or 3-10d box (3" × 0.128"); or 3-3" × 0.131" nails	Toe nail
22	Rim joist, band joist or blocking to sill or top plate (roof applications also)	8d box (2 ¹ / ₂ " × 0.113")	4" o.c. toe nail
		8d common (2 ¹ / ₂ " × 0.131"); or 10d box (3" × 0.128"); or 3" × 0.131" nails	6" o.c. toe nail
23	1" × 6" subfloor or less to each joist	3-8d box (2 ¹ / ₂ " × 0.113"); or 2-8d common	Face nail

		(2 ¹ / ₂ " × 0.131"); or 3-10d box (3" × 0.128"); or 2 staples, 1" crown, 16 ga., 1 ³ / ₄ " long		
Floor				
24	2" subfloor to joist or girder	3-16d box (3 ¹ / ₂ " × 0.135"); or 2-16d common (3 ¹ / ₂ " × 0.162")	Blind and face nail	
25	2" planks (plank & beam—floor & roof)	3-16d box (3 ¹ / ₂ " × 0.135"); or 2-16d common (3 ¹ / ₂ " × 0.162")	At each bearing, face nail	
26	Band or rim joist to joist	3-16d common (3 ¹ / ₂ " × 0.162") 4-10 box (3" × 0.128"), or 4-3" × 0.131" nails; or 4-3" × 14 ga. staples, 7/16" crown	End nail	
27	Built-up girders and beams, 2-inch lumber layers	20d common (4" × 0.192"); or	Nail each layer as follows: 32" o.c. at top and bottom and staggered.	
		10d box (3" × 0.128"); or 3" × 0.131" nails	24" o.c. face nail at top and bottom staggered on opposite sides	
		And: 2-20d common (4" × 0.192"); or 3-10d box (3" × 0.128"); or 3-3" × 0.131" nails	Face nail at ends and at each splice	
28	Ledger strip supporting joists or rafters	4-16d box (3 ¹ / ₂ " × 0.135"); or 3-16d common (3 ¹ / ₂ " × 0.162"); or 4-10d box (3" × 0.128"); or 4-3" × 0.131" nails	At each joist or rafter, face nail	
29	Bridging to joist	2-10d (3" × 0.128")	Each end, toe nail	
ITEM	DESCRIPTION OF BUILDING ELEMENTS	NUMBER AND TYPE OF FASTENER ^{a, b, c}	SPACING OF FASTENERS	
			Edges (inches) ^h	Intermediate supports ^{e, c} (inches)
Wood structural panels, subfloor, roof and interior wall sheathing to framing and particleboard wall sheathing to framing [see Table R602.3(3) for wood structural panel exterior wall sheathing to wall framing]				
30	3/8" – 1/2"	6d common (2" × 0.113") nail (subfloor, wall) ^g 8d common (2 ¹ / ₂ " × 0.131") nail (roof); or RSR-01 (2-3/8" × 0.113") nail (roof) ⁱ	6	12 ^f
31	19/32" – 1"	8d common nail (2 ¹ / ₂ " × 0.131"); or RSR-01 (2-3/8" × 0.113") nail (roof) ⁱ	6	12 ^f
32	1 ¹ / ₈ " – 1 ¹ / ₄ "	10d common (3" × 0.148") nail; or 8d (2 ¹ / ₂ " × 0.131") deformed nail	6	12
Other wall sheathing^g				
33	1/2" structural cellulosic fiberboard sheathing	1 ¹ / ₂ " galvanized roofing nail, 7/16" head diameter, or 1" crown staple 16 ga., 1 ¹ / ₄ " long	3	6
34	25/32" structural cellulosic fiberboard sheathing	1 ³ / ₄ " galvanized roofing nail, 7/16" head diameter, or 1" crown staple 16 ga., 1 ¹ / ₄ " long	3	6
35	1/2" gypsum sheathing ^d	1 ¹ / ₂ " galvanized roofing nail; staple galvanized, 1 ¹ / ₂ " long; 1 ¹ / ₄ " screws, Type W or S	7	7
36	5/8" gypsum sheathing ^d	1 ³ / ₄ " galvanized roofing nail; staple galvanized, 1 ⁵ / ₈ " long; 1 ⁵ / ₈ " screws, Type W or S	7	7
Wood structural panels, combination subfloor underlayment to framing				
37	3/4" and less	6d deformed (2" × 0.120") nail; or 8d common (2 ¹ / ₂ " × 0.131") nail	6	12

38	$7/8$ " – 1"	8d common ($2^{1/2}$ " × 0.131") nail; or 8d deformed ($2^{1/2}$ " × 0.120") nail	6	12
39	$1^{1/8}$ " – $1^{1/4}$ "	10d common (3" × 0.148") nail; or 8d deformed ($2^{1/2}$ " × 0.120") nail	6	12

For SI: 1 inch = 25.4 mm, 1 foot = 304.8 mm, 1 mile per hour = 0.447 m/s; 1 ksi = 6.895 MPa.

- a. Nails are smooth-common, box or deformed shanks except where otherwise stated. Nails used for framing and sheathing connections shall have minimum average bending yield strengths as shown: 80 ksi for shank diameter of 0.192 inch (20d common nail), 90 ksi for shank diameters larger than 0.142 inch but not larger than 0.177 inch, and 100 ksi for shank diameters of 0.142 inch or less.
- b. Staples are 16 gage wire and have a minimum $7/16$ -inch on diameter crown width.
- c. Nails shall be spaced at not more than 6 inches on center at all supports where spans are 48 inches or greater.
- d. Four-foot by 8-foot or 4-foot by 9-foot panels shall be applied vertically.
- e. Spacing of fasteners not included in this table shall be based on Table R602.3(2).
- f. Where the ultimate design wind speed is 130 mph or less, nails for attaching wood structural panel roof sheathing to gable end wall framing shall be spaced 6 inches on center. Where the ultimate design wind speed is greater than 130 mph, nails for attaching panel roof sheathing to intermediate supports shall be spaced 6 inches on center for minimum 48-inch distance from ridges, eaves and gable end walls; and 4 inches on center to gable end wall framing.
- g. Gypsum sheathing shall conform to ASTM C 1396 and shall be installed in accordance with GA 253. Fiberboard sheathing shall conform to ASTM C 208.
- h. Spacing of fasteners on floor sheathing panel edges applies to panel edges supported by framing members and required blocking and at floor perimeters only. Spacing of fasteners on roof sheathing panel edges applies to panel edges supported by framing members and required blocking. Blocking of roof or floor sheathing panel edges perpendicular to the framing members need not be provided except as required by other provisions of this code. Floor perimeter shall be supported by framing members or solid blocking.
- i. Where a rafter is fastened to an adjacent parallel ceiling joist in accordance with this schedule, provide two toe nails on one side of the rafter and toe nails from the ceiling joist to top plate in accordance with this schedule. The toe nail on the opposite side of the rafter shall not be required.
- j. RRS-01 is a Roof Sheathing Ring Shank nail meeting the specifications in ASTM F1667.

Reason: This change adds a new standardized roof sheathing ring shank (RSRS) nail for roof sheathing applications. The RSRS nail has been standardized in ASTM F1667 and added in this proposal as equivalent to the 8d common nail to resist uplift of roof sheathing. This standard ring shank nail provides improved withdrawal resistance relative to the 8d common smooth shank nail. A head size of 0.281" diameter is specified for the RSRS-01 in ASTM F1667 which is equivalent to the head diameter of the 8d common nail. The slightly larger net area under the head (i.e. area of head minus area of shank) is considered to provide slightly improved head pull through performance.

Cost Impact: Will not increase the cost of construction

An alternative nail is being added only, so there is no increase in cost since the current nailing alternatives may still be used.

Report of Committee Action Hearings

Committee Action:

Approved as Submitted

Committee Reason: This proposal adds a new ring shank nail for roof sheathing that provides improved withdrawal. The nail has been standardized in ASTM F1667.

Assembly Action:

None

Final Action Results

RB220-16

AS

Code Change No: **RB221-16**

Original Proposal

Section: R602.3, R803.2.3

Proponent: James Smith (jsmith@awc.org)

Revise as follow:

**TABLE R602.3 (1)
FASTENING SCHEDULE**

ITEM	DESCRIPTION OF BUILDING ELEMENTS	NUMBER AND TYPE OF FASTENER ^{a, b, c}	SPACING AND LOCATION
Roof			
1	Blocking between ceiling joists or rafters to top plate	4-8d box (2 ¹ / ₂ " × 0.113") or 3-8d common (2 ¹ / ₂ " × 0.131"); or 3-10d box (3" × 0.128"); or 3-3" × 0.131" nails	Toe nail
2	Ceiling joists to top plate	4-8d box (2 ¹ / ₂ " × 0.113"); or 3-8d common (2 ¹ / ₂ " × 0.131"); or 3-10d box (3" × 0.128"); or 3-3" × 0.131" nails	Per joist, toe nail
3	Ceiling joist not attached to parallel rafter, laps over partitions [see Sections R802.3.1, R802.3.2 and Table R802.5.1(9)]	4-10d box (3" × 0.128"); or 3-16d common (3 ¹ / ₂ " × 0.162"); or 4-3" × 0.131" nails	Face nail
4	Ceiling joist attached to parallel rafter (heel joint) [see Sections R802.3.1 and R802.3.2 and Table R802.5.1(9)]	Table R802.5.1(9)	Face nail
5	Collar tie to rafter, face nail or 1 ¹ / ₄ " × 20 ga. ridge strap to rafter	4-10d box (3" × 0.128"); or 3-10d common (3" × 0.148"); or 4-3" × 0.131" nails	Face nail each rafter
6	Rafter or roof truss to plate	3-16d box nails (3 ¹ / ₂ " × 0.135"); or 3-10d common nails (3" × 0.148"); or 4-10d box (3" × 0.128"); or 4-3" × 0.131" nails	2 toe nails on one side and 1 toe nail on opposite side of each rafter or truss ⁱ
7	Roof rafters to ridge, valley or hip rafters or roof rafter to minimum 2" ridge beam	4-16d (3 ¹ / ₂ " × 0.135"); or 3-10d common (3 ¹ / ₂ " × 0.148"); or 4-10d box (3" × 0.128"); or 4-3" × 0.131" nails 3-16d box 3 ¹ / ₂ " × 0.135"); or 2-16d common (3 ¹ / ₂ " × 0.162"); or 3-10d box (3" × 0.128"); or 3-3" × 0.131" nails	Toe nail End nail
Wall			
8	Stud to stud (not at braced wall panels)	16d common (3 ¹ / ₂ " × 0.162") 10d box (3" × 0.128"); or 3" × 0.131" nails	24" o.c. face nail 16" o.c. face nail
9	Stud to stud and abutting studs at intersecting wall corners (at braced wall panels)	16d box (3 ¹ / ₂ " × 0.135"); or 3" × 0.131" nails 16d common (3 ¹ / ₂ " × 0.162")	12" o.c. face nail 16" o.c. face nail
10	Built-up header (2" to 2" header with 1 ¹ / ₂ " spacer)	16d common (3 ¹ / ₂ " × 0.162") 16d box (3 ¹ / ₂ " × 0.135")	16" o.c. each edge face nail 12" o.c. each edge face nail
11	Continuous header to stud	5-8d box (2 ¹ / ₂ " × 0.113"); or 4-8d common (2 ¹ / ₂ " × 0.131"); or 4-10d box (3" × 0.128")	Toe nail

12	Top plate to top plate	16d common (3 ¹ / ₂ " × 0.162")	16" o.c. face nail
		10d box (3" × 0.128"); or 3" × 0.131" nails	12" o.c. face nail
13	Double top plate splice for SDCs A-D2 with seismic braced wall line spacing	8-16d common (3 ¹ / ₂ " × 0.162"); or 12-16d box (3 ¹ / ₂ " × 0.135"); or 12-10d box (3" × 0.128"); or 12-3" × 0.131" nails	Face nail on each side of end joint (minimum 24" lap splice length each side of end joint)
	Double top plate splice SDCs D ₀ , D ₁ , or D ₂ ; and braced wall line spacing ≥ 25'	12-16d (3 ¹ / ₂ " × 0.135")	
ITEM	DESCRIPTION OF BUILDING ELEMENTS	NUMBER AND TYPE OF FASTENER ^{a, b, c}	SPACING AND LOCATION
14	Bottom plate to joist, rim joist, band joist or blocking (not at braced wall panels)	16d common (3 ¹ / ₂ " × 0.162")	16" o.c. face nail
		16d box (3 ¹ / ₂ " × 0.135"); or 3" × 0.131" nails	12" o.c. face nail
15	Bottom plate to joist, rim joist, band joist or blocking (at braced wall panel)	3-16d box (3 ¹ / ₂ " × 0.135"); or 2-16d common (3 ¹ / ₂ " × 0.162"); or 4-3" × 0.131" nails	3 each 16" o.c. face nail 2 each 16" o.c. face nail 4 each 16" o.c. face nail
16	Top or bottom plate to stud	4-8d box (2 ¹ / ₂ " × 0.113"); or 3-16d box (3 ¹ / ₂ " × 0.135"); or 4-8d common (2 ¹ / ₂ " × 0.131"); or 4-10d box (3" × 0.128"); or 4-3" × 0.131" nails	Toe nail
		3-16d box (3 ¹ / ₂ " × 0.135"); or 2-16d common (3 ¹ / ₂ " × 0.162"); or 3-10d box (3" × 0.128"); or 3-3" × 0.131" nails	End nail
17	Top plates, laps at corners and intersections	3-10d box (3" × 0.128"); or 2-16d common (3 ¹ / ₂ " × 0.162"); or 3-3" × 0.131" nails	Face nail
18	1" brace to each stud and plate	3-8d box (2 ¹ / ₂ " × 0.113"); or 2-8d common (2 ¹ / ₂ " × 0.131"); or 2-10d box (3" × 0.128"); or 2 staples 1 ³ / ₄ "	Face nail
19	1" × 6" sheathing to each bearing	3-8d box (2 ¹ / ₂ " × 0.113"); or 2-8d common (2 ¹ / ₂ " × 0.131"); or 2-10d box (3" × 0.128"); or 2 staples, 1" crown, 16 ga., 1 ³ / ₄ " long	Face nail
20	1" × 8" and wider sheathing to each bearing	3-8d box (2 ¹ / ₂ " × 0.113"); or 3-8d common (2 ¹ / ₂ " × 0.131"); or 3-10d box (3" × 0.128"); or 3 staples, 1" crown, 16 ga., 1 ³ / ₄ " long	Face nail
		Wider than 1" × 8" 4-8d box (2 ¹ / ₂ " × 0.113"); or 3-8d common (2 ¹ / ₂ " × 0.131"); or 3-10d box (3" × 0.128"); or 4 staples, 1" crown, 16 ga., 1 ³ / ₄ " long	
Floor			
21	Joist to sill, top plate or girder	4-8d box (2 ¹ / ₂ " × 0.113"); or 3-8d common (2 ¹ / ₂ " × 0.131"); or 3-10d box (3" × 0.128"); or 3-3" × 0.131" nails	Toe nail
22	Rim joist, band joist or blocking to sill or top plate (roof applications also)	8d box (2 ¹ / ₂ " × 0.113")	4" o.c. toe nail
		8d common (2 ¹ / ₂ " × 0.131"); or 10d box (3" × 0.128"); or 3" × 0.131" nails	6" o.c. toe nail
23	1" × 6" subfloor or less to each joist	3-8d box (2 ¹ / ₂ " × 0.113"); or 2-8d common (2 ¹ / ₂ " × 0.131"); or 3-10d box (3" × 0.128"); or 2 staples, 1" crown, 16 ga., 1 ³ / ₄ " long	Face nail

ITEM	DESCRIPTION OF BUILDING ELEMENTS	NUMBER AND TYPE OF FASTENER ^{a, b, c}	SPACING AND LOCATION
Floor			
24	2" subfloor to joist or girder	3-16d box (3 ¹ / ₂ " × 0.135"); or 2-16d common (3 ¹ / ₂ " × 0.162")	Blind and face nail
25	2" planks (plank & beam—floor & roof)	3-16d box (3 ¹ / ₂ " × 0.135"); or 2-16d common (3 ¹ / ₂ " × 0.162")	At each bearing, face nail
26	Band or rim joist to joist	3-16d common (3 ¹ / ₂ " × 0.162") 4-10 box (3" × 0.128"), or 4-3" × 0.131" nails; or 4-3" ×	End nail

		14 ga. staples, ⁷ / ₁₆ " crown		
27	Built-up girders and beams, 2-inch lumber layers	20d common (4"× 0.192"); or	Nail each layer as follows: 32"o.c. at top and bottom and staggered.	
		10d box (3"× 0.128"); or 3"× 0.131"nails	24"o.c. face nail at top and bottom staggered on opposite sides	
		And: 2-20d common (4"× 0.192"); or 3-10d box (3"× 0.128"); or 3-3"× 0.131"nails	Face nail at ends and at each splice	
28	Ledger strip supporting joists or rafters	4-16d box (3 ¹ / ₂ "× 0.135"); or 3-16d common (3 ¹ / ₂ "× 0.162"); or 4-10d box (3"× 0.128"); or 4-3"× 0.131"nails	At each joist or rafter, face nail	
29	Bridging to joist	2-10d (3"× 0.128")	Each end, toe nail	
ITEM	DESCRIPTION OF BUILDING ELEMENTS	NUMBER AND TYPE OF FASTENER ^{a, b, c}	SPACING OF FASTENERS	
			Panel Edges (inches) ^h	Intermediate supports ^{c, e} (inches)
Wood structural panels, subfloor, roof and interior wall sheathing to framing and particleboard wall sheathing to framing [see Table R602.3(3) for wood structural panel exterior wall sheathing to wall framing]				
30	³ / ₈ " – ¹ / ₂ "	6d common (2"× 0.113") nail (subfloor, wall) ⁱ 8d common (2 ¹ / ₂ "× 0.131") nail (roof)	6	12 ^f
31	¹⁹ / ₃₂ " – 1"	8d common nail (2 ¹ / ₂ "× 0.131")	6	12 ^f
32	1 ¹ / ₈ " – 1 ¹ / ₄ "	10d common (3"× 0.148") nail; or 8d (2 ¹ / ₂ "× 0.131") deformed nail	6	6
33	¹ / ₂ " structural cellulosic fiberboard sheathing	1 ¹ / ₂ " galvanized roofing nail, ⁷ / ₁₆ " head diameter, or 1" crown staple 16 ga., 1 ¹ / ₄ " long	3	6
34	²⁵ / ₃₂ " structural cellulosic fiberboard sheathing	1 ³ / ₄ " galvanized roofing nail, ⁷ / ₁₆ " head diameter, or 1" crown staple 16 ga., 1 ¹ / ₄ " long	3	7
35	¹ / ₂ " gypsum sheathing ^d	1 ¹ / ₂ " galvanized roofing nail; staple galvanized, 1 ¹ / ₂ " long; 1 ¹ / ₄ " screws, Type W or S	7	7
36	⁵ / ₈ " gypsum sheathing ^d	1 ³ / ₄ " galvanized roofing nail; staple galvanized, 1 ⁵ / ₈ " long; 1 ⁵ / ₈ " screws, Type W or S	7	12
37	³ / ₄ " and less	6d deformed (2"× 0.120") nail; or 8d common (2 ¹ / ₂ "× 0.131") nail	6	12
38	⁷ / ₈ " – 1"	8d common (2 ¹ / ₂ "× 0.131") nail; or 8d deformed (2 ¹ / ₂ "× 0.120") nail	6	12
39	1 ¹ / ₈ " – 1 ¹ / ₄ "	10d common (3"× 0.148") nail; or 8d deformed (2 ¹ / ₂ "× 0.120") nail	6	12

For SI: 1 inch = 25.4 mm, 1 foot = 304.8 mm, 1 mile per hour = 0.447 m/s; 1 ksi = 6.895 MPa.

a. Nails are smooth-common, box or deformed shanks except where otherwise stated. Nails used for framing and sheathing connections shall have minimum average bending yield strengths as shown: 80 ksi for shank diameter of 0.192 inch (20d common nail), 90 ksi for shank diameters larger than 0.142 inch but not larger than 0.177 inch, and 100 ksi for shank diameters of 0.142 inch or less.

b. Staples are 16 gage wire and have a minimum ⁷/₁₆-inch on diameter crown width.

c. Nails shall be spaced at not more than 6 inches on center at all supports where spans are 48 inches or greater.

d. Four-foot by 8-foot or 4-foot by 9-foot panels shall be applied vertically.
e. Spacing of fasteners not included in this table shall be based on Table R602.3(2).
f. Where the ultimate design wind speed is 130 mph or less, nails for attaching wood structural panel roof sheathing to gable end wall framing shall be spaced 6 inches on center. Where the ultimate design wind speed is greater than 130 mph, nails for attaching panel roof sheathing to intermediate supports shall be spaced 6 inches on center for minimum 48-inch distance from ridges, eaves and gable end walls; and 4 inches on center to gable end wall framing.
f. <u>For wood structural panel roof sheathing attached to gable end roof framing and to intermediate supports within 48" of roof end zones, eaves, and ridges, nails shall be spaced at 6 inches on center where the ultimate design wind speed is less than 130 mph and shall be spaced 4 inches on center where the ultimate design wind speed is 130 mph or greater but less than 140 mph.</u>
g. Gypsum sheathing shall conform to ASTM C 1396 and shall be installed in accordance with GA 253. Fiberboard sheathing shall conform to ASTM C 208.
h. Spacing of fasteners on floor sheathing panel edges applies to panel edges supported by framing members and required blocking and at floor perimeters only. Spacing of fasteners on roof sheathing panel edges applies to panel edges supported by framing members and required blocking. Blocking of roof or floor sheathing panel edges perpendicular to the framing members need not be provided except as required by other provisions of this code. Floor perimeter shall be supported by framing members or solid blocking.
i. Where a rafter is fastened to an adjacent parallel ceiling joist in accordance with this schedule, provide two toe nails on one side of the rafter and toe nails from the ceiling joist to top plate in accordance with this schedule. The toe nail on the opposite side of the rafter shall not be required.

R803.2.3 Installation. Wood structural panel used as roof sheathing shall be installed with joints staggered or not staggered in accordance with Table R602.3(1), APA E30 for wood roof framing or with Table R804.3 for cold-formed steel roof framing. Wood structural panel roof sheathing shall not cantilever more than 9 inches beyond the gable end wall unless supported by gable overhang framing.

Reason: Nailing requirements provided in the IRC Table 602.3(1) were reviewed using loads from ASCE 7-10 *Minimum Design Loads for Buildings and Other Structures*. Nailing requirements for common species of roof framing with specific gravities of 0.42 or greater (e.g. SPF, Hem-Fir) were analyzed and it was found that the nail spacing requirements in footnote "f" needed to be slightly modified to clarify that nail spacing for all sheathing to framing attached to intermediate supports within 48" of roof end zones, eaves, and ridges must be reduced, not just at the gable end roof framing. For ultimate wind speeds of 130 mph and greater, the threshold for reducing the nail spacing from 6" to 4" in the 48" end zone areas was slightly modified while clarifying that ultimate wind speeds of 140 mph or greater are outside the scope of the IRC structural provisions. The language in footnote "f" was revised to clarify the intent of this footnote. A sentence was also added to R803.2.3 to clarify the appropriate limit on the distance unsupported sheathing can cantilever past the gable end roof framing. Tabulated calculation results based on ASCE 7-10 are provided below: (insert attachment here)

WFCM Table 3.10 [Exposure C] - Based on ASCE 7-10
Roof Sheathing Attachment Requirements for Wind Loads

700-yr. Wind Speed 3-second gust (mph)			110	115	120	130	140			
			Wood Structural Panel Sheathing							
			E	F	E	F	E	F		
Sheathing Location ¹	Rafter/Truss Framing Specific Gravity, G	Rafter/Truss Spacing (in.)	Maximum Nail Spacing for 8d Common Nails or 10d Box Nails (inches, o.c.) ²							
Interior Zone	0.42	12	6	12	6	12	6	12	6	12
		16	6	12	6	12	6	12	6	12
		19.2	6	12	6	12	6	12	6	12
		24	6	12	6	12	6	12	6	12
Perimeter Edge Zone	0.42	12	6	12	6	12	6	12	6	6
		16	6	12	6	6	6	6	6	6
		19.2	6	6	6	6	6	6	6	6
		24	6	6	6	6	6	6	4	6
Gable Endwall Rake or Rake Truss with up to 9" Rake Overhang	0.42	-	6	6	6	4	4			

E - Nail spacing at panel edges (in.)
F - Nail spacing at intermediate supports in the panel field (in.)

1 For roof sheathing within 4 feet of the perimeter edge of the roof, including 4 feet on each side of the roof peak, the 4 foot perimeter edge zone attachment requirements shall be used.
2 For wind speeds greater than 130 mph, blocking is required which transfers shear load to two additional joists.

Cost Impact: Will not increase the cost of construction

The change to footnote "f" is a clarification of the current footnote "f" intent. The 9" limit on gable overhang is not really an increase in requirement, but a limitation to allow more efficient nailing patterns.

Report of Committee Action Hearings

Committee Action:

Approved as Modified

Modify as follows:

**TABLE R602.3 (1)
FASTENING SCHEDULE**

For SI: 1 inch = 25.4 mm, 1 foot = 304.8 mm, 1 mile per hour = 0.447 m/s; 1 ksi = 6.895 MPa.

- a. Nails are smooth-common, box or deformed shanks except where otherwise stated. Nails used for framing and sheathing connections shall have minimum average bending yield strengths as shown: 80 ksi for shank diameter of 0.192 inch (20d common nail), 90 ksi for shank diameters larger than 0.142 inch but not larger than 0.177 inch, and 100 ksi for shank diameters of 0.142 inch or less.
- b. Staples are 16 gage wire and have a minimum ⁷/₁₆ -inch on diameter crown width.
- c. Nails shall be spaced at not more than 6 inches on center at all supports where spans are 48 inches or greater.
- d. Four-foot by 8-foot or 4-foot by 9-foot panels shall be applied vertically.
- e. Spacing of fasteners not included in this table shall be based on Table R602.3(2).
- f. For wood structural panel roof sheathing attached to gable end roof framing and to intermediate supports within 48" of roof-end zones, eaves, edges and ridges, nails shall be spaced at 6 inches on center where the ultimate design wind speed is less than 130 mph and shall be spaced 4 inches on center where the ultimate design wind speed is 130 mph or greater but less than 140 mph.

g. Gypsum sheathing shall conform to ASTM C 1396 and shall be installed in accordance with GA 253. Fiberboard sheathing shall conform to ASTM C 208.

h. Spacing of fasteners on floor sheathing panel edges applies to panel edges supported by framing members and required blocking and at floor perimeters only. Spacing of fasteners on roof sheathing panel edges applies to panel edges supported by framing members and required blocking. Blocking of roof or floor sheathing panel edges perpendicular to the framing members need not be provided except as required by other provisions of this code. Floor perimeter shall be supported by framing members or solid blocking.

i. Where a rafter is fastened to an adjacent parallel ceiling joist in accordance with this schedule, provide two toe nails on one side of the rafter and toe nails from the ceiling joist to top plate in accordance with this schedule. The toe nail on the opposite side of the rafter shall not be required.

R803.2.3 Installation. Wood structural panel used as roof sheathing shall be installed with joints staggered or not staggered in accordance with Table R602.3(1), APA E30 for wood roof framing or with Table R804.3 for cold-formed steel roof framing. Wood structural panel roof sheathing in accordance with Table R503.2.1.1(1) shall not cantilever more than 9 inches beyond the gable end wall unless supported by gable overhang framing.

Committee Reason: The committee approved this change based on the proponents published reason statement. The proposal aligns the roof sheathing nail spacing with the ASCE 7-10 loading and provides an allowable cantilever for the sheathing past the gable end. The modifications deleted the terms end zones and eaves to avoid confusion with edges and added a reference to the sheathing installation table.

Assembly Action

None

Final Action Results

RB221-16

AM

Code Change No: **RB226-16**

Original Proposal

Section: R602.7, R602.7(2) (New)

Proponent: David Tyree, representing American Wood Council (dtyree@awc.org)

Revise as follows:

TABLE R602.7

GIRDER SPANS^a AND HEADER SPANS^a FOR INTERIOR BEARING WALLS (Maximum spans for Douglas fir-larch, hem-fir, southern pine and spruce-pine-fir^b and required number of jack studs)

HEADERS AND GIRDERS SUPPORTING	SIZE	BUILDING Width ^c (feet)					
		20		28		36	
		Span	NJ ^d	Span	NJ ^d	Span	NJ ^d
One floor only	2-2 x 4	3-4	1	2-8	1	2-5	1
	2-2 x 6	4-6	1	3-11	1	3-6	1
	2-2 x 8	5-9	1	5-0	2	4-5	2
	2-2 x 10	7-0	2	6-4	2	5-5	2
	2-2 x 12	8-4	2	7-0	2	6-3	2
	3-2 x 8	7-2	1	6-3	1	5-7	2
	3-2 x 10	8-9	1	7-7	2	6-9	2
	3-2 x 12	10-2	2	8-10	2	7-10	2
	4-2 x 8	9-0	1	7-8	1	6-9	1
	4-2 x 10	10-4	1	8-9	1	7-10	2
4-2 x 12	11-9	1	10-2	2	9-4	2	
Two floors	2-2 x 4	2-2	1	1-10	1	1-7	1
	2-2 x 6	3-2	2	2-9	2	2-5	2
	2-2 x 8	4-4	2	3-6	2	3-2	2
	2-2 x 10	4-11	2	4-3	2	3-10	3
	2-2 x 12	5-9	2	5-0	3	4-5	3
	3-2 x 8	5-4	2	4-5	2	3-11	2
	3-2 x 10	6-2	2	5-4	2	4-10	2
	3-2 x 12	7-2	2	6-3	2	5-7	3
	4-2 x 8	6-4	1	5-3	2	4-8	2
	4-2 x 10	7-2	2	6-2	2	5-6	2
4-2 x 12	8-4	2	7-2	2	6-5	2	

For SI: 1 inch = 25.4 mm, 1 foot = 304.8 mm.

- Spans are given in feet and inches.
- No. 1 or better grade lumber shall be used for southern pine. Other tabulated values assume #2 grade lumber.
- Building width is measured perpendicular to the ridge. For widths between those shown, spans are permitted to be interpolated.
- NJ = Number of jack studs required to support each end. Where the number of required jack studs equals one, the header is permitted to be supported by an approved framing anchor attached to the full-height wall stud and to the header.

TABLE R602.7(2)
GIRDER SPANS^a AND HEADER SPANS^a FOR INTERIOR BEARING WALLS (Maximum spans for Douglas fir-larch, hem-fir, southern pine, and spruce-pine-fir^b and required number of jack studs)

HEADERS AND GIRDERS SUPPORTING	SIZE	BUILDING Width ^c (feet)					
		12		24		36	
		Span ^e	NJ ^d	Span ^e	NJ ^d	Span ^e	NJ ^d
One floor only	2- 2x4	4 - 1	1	2 - 10	1	2 - 4	1
	2- 2x6	6 - 1	1	4 - 4	1	3 - 6	1
	2- 2x8	7 - 9	1	5 - 5	1	4 - 5	2
	2- 2x10	9 - 2	1	6 - 6	2	5 - 3	2
	2- 2x12	10 - 9	1	7 - 7	2	6 - 3	2
	3- 2x8	9 - 8	1	6 - 10	1	5 - 7	1
	3- 2x10	11 - 5	1	8 - 1	1	6 - 7	2
	3- 2x12	13 - 6	1	9 - 6	2	7 - 9	2
	4- 2x8	11 - 2	1	7 - 11	1	6 - 5	1
	4- 2x10	13 - 3	1	9 - 4	1	7 - 8	1
	4- 2x12	15 - 7	1	11 - 0	1	9 - 0	2
	Two floors	2- 2x4	2 - 7	1	1 - 11	1	1 - 7
2- 2x6		3 - 11	1	2 - 11	2	2 - 5	2
2- 2x8		5 - 0	1	3 - 8	2	3 - 1	2
2- 2x10		5 - 11	2	4 - 4	2	3 - 7	2
2- 2x12		6 - 11	2	5 - 2	2	4 - 3	3
3- 2x8		6 - 3	1	4 - 7	2	3 - 10	2
3- 2x10		7 - 5	1	5 - 6	2	4 - 6	2
3- 2x12		8 - 8	2	6 - 5	2	5 - 4	2
4- 2x8		7 - 2	1	5 - 4	1	4 - 5	2
4- 2x10		8 - 6	1	6 - 4	2	5 - 3	2
4- 2x12		10 - 1	1	7 - 5	2	6 - 2	2

For SI: 1 inch = 25.4 mm, 1 pound per square foot = 0.0479 kPa_s

a. Spans are given in feet and inches.

- b. Spans are based on minimum design properties for No. 2 grade lumber of Douglas Fir-Larch, Hem-Fir, Southern Pine, and Spruce-Pine-Fir.
- c. Building width is measured perpendicular to the ridge. For widths between those shown, spans are permitted to be interpolated.
- d. NJ - Number of jack studs required to support each end. Where the number of required jack studs equals one, the header is permitted to be supported by an approved framing anchor attached to the full-height wall stud and to the header.
- e. Spans are calculated assuming the top of the header or girder is laterally braced by perpendicular framing. Where the top of the header or girder is not laterally braced (e.g. cripple studs bearing on the header), tabulated spans for headers consisting of 2x8, 2x10, or 2x12 sizes shall be multiplied by 0.70 or the header or girder shall be designed.

Reason: The update of Table R602.7(2) Girder Spans and Header Spans for Interior Bearing Walls is proposed. Updated spans address use of Southern Pine No. 2 in lieu of Southern Pine No. 1. Footnote "e" is added to clarify that header spans are based on laterally braced assumption such as when the header is raised. For dropped headers consisting of 2x8, 2x10, or 2x12 sizes that are not laterally braced, a factor of 0.7 can be applied to determine the spans or alternatively the header or girder can be designed to include any adjustment for potential buckling. Laterally braced (raised) and not laterally braced (dropped) header conditions and building widths for which header spans are tabulated represent the same conditions used to develop header span tables in the Wood Frame Construction Manual (WFCM).

Cost Impact: Will increase the cost of construction

Increased cost may be associated with reduced spans that result from the not laterally braced condition and application of footnote e. Due to smaller building width column (12'), permissible use of Southern Pine No. 2, and the laterally braced assumption for tabulated spans, there are also cases where this change will not increase the cost of construction and may reduce cost of construction.

Report of Committee Action Hearings
--

Committee Action:

Approved as Submitted

Committee Reason: The table replaces the existing and allows the use of No. 2 grade southern pine as stated in the proponents published reason statement.

Assembly Action:

None

Final Action Results

RB226-16

AS

Code Change No: RB227-16

Original Proposal

Section: R602.7, R602.7(1) (New)

Proponent: David Tyree, representing American Wood Council (dtyree@awc.org)

Revise as follows:

TABLE R602.7
GIRDER SPANS* AND HEADER SPANS* FOR EXTERIOR BEARING WALLS (Maximum spans for Douglas fir-larch, hem-fir, southern pine and spruce-pine-fir* and required number of jack studs)

GIRDERS AND HEADERS SUPPORTING	SIZE	GROUND SNOW LOAD (psf) ^g																		
		30						50						70						
		Building width ^e (feet)																		
		20			28			36			20			28			36			
Span		NJ ^d	Span		NJ ^d	Span		NJ ^d	Span		NJ ^d	Span		NJ ^d	Span		NJ ^d	Span		NJ ^d
Roof and ceiling	1-2 x 8	4-6	1	3-10	1	3-5	1	3-9	1	3-2	1	2-10	2	—	—	—	—	—	—	
	1-2 x 10	5-8	1	4-11	1	4-4	1	4-9	1	4-1	1	3-7	2	—	—	—	—	—	—	
	1-2 x 12	6-11	1	5-11	2	5-3	2	5-9	2	4-8	2	3-8	2	—	—	—	—	—	—	
	2-2 x 4	3-6	1	3-2	1	2-10	1	3-2	1	2-9	1	2-6	1	2-10	1	2-6	1	2-3	1	
	2-2 x 6	5-5	1	4-8	1	4-2	1	4-8	1	4-1	1	3-8	2	4-2	1	3-8	2	3-3	2	
	2-2 x 8	6-10	1	5-11	2	5-4	2	5-11	2	5-2	2	4-7	2	5-4	2	4-7	2	4-1	2	
	2-2 x 10	8-5	2	7-3	2	6-6	2	7-3	2	6-3	2	5-7	2	6-6	2	5-7	2	5-0	2	
	2-2 x 12	9-9	2	8-5	2	7-6	2	8-5	2	7-3	2	6-6	2	7-6	2	6-6	2	5-10	3	
	3-2 x 8	8-4	1	7-5	1	6-8	1	7-5	1	6-5	2	5-9	2	6-8	1	5-9	2	5-2	2	
	3-2 x 10	10-6	1	9-1	2	8-2	2	9-1	2	7-10	2	7-0	2	8-2	2	7-0	2	6-4	2	
	3-2 x 12	12-2	2	10-7	2	9-5	2	10-7	2	9-2	2	8-2	2	9-5	2	8-2	2	7-4	2	
	4-2 x 8	9-2	1	8-4	1	7-8	1	8-4	1	7-5	1	6-8	1	7-8	1	6-8	1	5-11	2	
	4-2 x 10	11-8	1	10-6	1	9-5	2	10-6	1	9-1	2	8-2	2	9-5	2	8-2	2	7-3	2	
4-2 x 12	14-1	1	12-2	2	10-11	2	12-2	2	10-7	2	9-5	2	10-11	2	9-5	2	8-5	2		
Roof, ceiling and one center-bearing floor	1-2 x 8	3-11	1	3-5	1	3-0	1	3-7	1	3-0	2	2-8	2	—	—	—	—	—	—	
	1-2 x 10	5-0	2	4-4	2	3-10	2	4-6	2	3-11	2	3-4	2	—	—	—	—	—	—	
	1-2 x 12	5-10	2	4-9	2	4-2	2	5-5	2	4-2	2	3-4	2	—	—	—	—	—	—	
	2-2 x 4	3-1	1	2-9	1	2-5	1	2-9	1	2-5	1	2-2	1	2-7	1	2-3	1	2-0	1	
	2-2 x 6	4-6	1	4-0	1	3-7	2	4-1	1	3-7	2	3-3	2	3-9	2	3-3	2	2-11	2	
	2-2 x 8	5-9	2	5-0	2	4-6	2	5-2	2	4-6	2	4-1	2	4-9	2	4-2	2	3-9	2	
	2-2 x 10	7-0	2	6-2	2	5-6	2	6-4	2	5-6	2	5-0	2	5-9	2	5-1	2	4-7	3	
	2-2 x 12	8-1	2	7-1	2	6-5	2	7-4	2	6-5	2	5-9	3	6-8	2	5-10	3	5-3	3	
	3-2 x 8	7-2	1	6-3	2	5-8	2	6-5	2	5-8	2	5-1	2	5-11	2	5-2	2	4-8	2	
	3-2 x 10	8-9	2	7-8	2	6-11	2	7-11	2	6-11	2	6-3	2	7-3	2	6-4	2	5-8	2	
	3-2 x 12	10-2	2	8-11	2	8-0	2	9-2	2	8-0	2	7-3	2	8-5	2	7-4	2	6-7	2	
	4-2 x 8	8-1	1	7-3	1	6-7	1	7-5	1	6-6	1	5-11	2	6-10	1	6-0	2	5-5	2	
	4-2 x 10	10-1	1	8-10	2	8-0	2	9-1	2	8-0	2	7-2	2	8-4	2	7-4	2	6-7	2	
4-2 x 12	11-9	2	10-3	2	9-3	2	10-7	2	9-3	2	8-4	2	9-8	2	8-6	2	7-7	2		

Roof, ceiling and one clear span floor	4-2 x 8	3-6	1	3-0	1	2-8	1	3-5	1	2-11	1	2-7	2	—	—	—	—	—	
	4-2 x 10	4-6	1	3-10	1	3-3	1	4-4	1	3-9	1	3-1	2	—	—	—	—	—	
	4-2 x 12	5-6	1	4-2	2	3-3	2	5-4	2	3-11	2	3-1	2	—	—	—	—	—	
	2-2 x 4	2-8	1	2-4	1	2-1	1	2-7	1	2-3	1	2-0	1	2-5	1	2-1	1	1-10	1
	2-2 x 6	3-11	1	3-5	2	3-0	2	3-10	2	3-4	2	3-0	2	3-6	2	3-1	2	2-9	2
	2-2 x 8	5-0	2	4-4	2	3-10	2	4-10	2	4-2	2	3-9	2	4-6	2	3-11	2	3-6	2
	2-2 x 10	6-1	2	5-3	2	4-8	2	5-11	2	5-1	2	4-7	3	5-6	2	4-9	2	4-3	3
	2-2 x 12	7-1	2	6-1	3	5-5	3	6-10	2	5-11	3	5-4	3	6-4	2	5-6	3	5-0	3
	3-2 x 8	6-3	2	5-5	2	4-10	2	6-1	2	5-3	2	4-8	2	5-7	2	4-11	2	4-5	2
	3-2 x 10	7-7	2	6-7	2	5-11	2	7-5	2	6-5	2	5-9	2	6-10	2	6-0	2	5-4	2
	3-2 x 12	8-10	2	7-8	2	6-10	2	8-7	2	7-5	2	6-8	2	7-11	2	6-11	2	6-3	2
	4-2 x 8	7-2	1	6-3	2	5-7	2	7-0	1	6-1	2	5-5	2	6-6	1	5-8	2	5-1	2
	4-2 x 10	8-9	2	7-7	2	6-10	2	8-7	2	7-5	2	6-7	2	7-11	2	6-11	2	6-2	2
	4-2 x 12	10-2	2	8-10	2	7-11	2	9-11	2	8-7	2	7-8	2	9-2	2	8-0	2	7-2	2

GIRDERS AND HEADERS SUPPORTING	SIZE	GROUND SNOW LOAD (psf) ^e																	
		30				50				70									
		Building width ^c (feet)																	
		20		28		36		20		28		36							
Span	NJ ^d	Span	NJ ^d	Span	NJ ^d	Span	NJ ^d	Span	NJ ^d	Span	NJ ^d	Span	NJ ^d	Span	NJ ^d				
Roof, ceiling and two center-bearing floors	2-2 x 4	2-7	1	2-3	1	2-0	1	2-6	1	2-2	1	1-11	1	2-4	1	2-0	1	1-9	1
	2-2 x 6	3-9	2	3-3	2	2-11	2	3-8	2	3-2	2	2-10	2	3-5	2	3-0	2	2-8	2
	2-2 x 8	4-9	2	4-2	2	3-9	2	4-7	2	4-0	2	3-8	2	4-4	2	3-9	2	3-5	2
	2-2 x 10	5-9	2	5-1	2	4-7	3	5-8	2	4-11	2	4-5	3	5-3	2	4-7	3	4-2	3
	2-2 x 12	6-8	2	5-10	3	5-3	3	6-6	2	5-9	3	5-2	3	6-1	3	5-4	3	4-10	3
	3-2 x 8	5-11	2	5-2	2	4-8	2	5-9	2	5-1	2	4-7	2	5-5	2	4-9	2	4-3	2
	3-2 x 10	7-3	2	6-4	2	5-8	2	7-1	2	6-2	2	5-7	2	6-7	2	5-9	2	5-3	2
	3-2 x 12	8-5	2	7-4	2	6-7	2	8-2	2	7-2	2	6-5	3	7-8	2	6-9	2	6-1	3
	4-2 x 8	6-10	1	6-0	2	5-5	2	6-8	1	5-10	2	5-3	2	6-3	2	5-6	2	4-11	2
	4-2 x 10	8-4	2	7-4	2	6-7	2	8-2	2	7-2	2	6-5	2	7-7	2	6-8	2	6-0	2
4-2 x 12	9-8	2	8-6	2	7-8	2	9-5	2	8-3	2	7-5	2	8-10	2	7-9	2	7-0	2	
Roof, ceiling, and two clear span floors	2-2 x 4	2-1	1	1-8	1	1-6	2	2-0	1	1-8	1	1-5	2	2-0	1	1-8	1	1-5	2
	2-2 x 6	3-1	2	2-8	2	2-4	2	3-0	2	2-7	2	2-3	2	2-11	2	2-7	2	2-3	2
	2-2 x 8	3-10	2	3-4	2	3-0	3	3-10	2	3-4	2	2-11	3	3-9	2	3-3	2	2-11	3
	2-2 x 10	4-9	2	4-1	3	3-8	3	4-8	2	4-0	3	3-7	3	4-7	3	4-0	3	3-6	3
	2-2 x 12	5-6	3	4-9	3	4-3	3	5-5	3	4-8	3	4-2	3	5-4	3	4-7	3	4-1	4
	3-2 x 8	4-10	2	4-2	2	3-9	2	4-9	2	4-1	2	3-8	2	4-8	2	4-1	2	3-8	2
	3-2 x 10	5-11	2	5-1	2	4-7	3	5-10	2	5-0	2	4-6	3	5-9	2	4-11	2	4-5	3
	3-2 x 12	6-10	2	5-11	3	5-4	3	6-9	2	5-10	3	5-3	3	6-8	2	5-9	3	5-2	3
	4-2 x 8	5-7	2	4-10	2	4-4	2	5-6	2	4-9	2	4-3	2	5-5	2	4-8	2	4-2	2
	4-2 x 10	6-10	2	5-11	2	5-3	2	6-9	2	5-10	2	5-2	2	6-7	2	5-9	2	5-1	2
4-2 x 12	7-11	2	6-10	2	6-2	3	7-9	2	6-9	2	6-0	3	7-8	2	6-8	2	5-11	3	

For SI: 1 inch = 25.4 mm, 1 pound per square foot = 0.0479 kPa.

- a. Spans are given in feet and inches.
- b. No. 1 or better grade lumber shall be used for southern pine. Other tabulated values assume #2 grade lumber.
- c. Building width is measured perpendicular to the ridge. For widths between those shown, spans are permitted to be interpolated.
- d. NJ = Number of jack studs required to support each end. Where the number of required jack studs equals one, the header is permitted to be supported by an approved framing anchor attached to the full-height wall stud and to the header.
- e. Use 30 psf ground snow load for cases in which ground snow load is less than 30 psf and the roof live load is equal to or less than 20 psf.

TABLE R602.7(1)
GIRDER SPANS^a AND HEADER SPANS^a FOR EXTERIOR BEARING WALLS (Maximum spans for Douglas fir-larch, hem-fir, southern pine, and spruce-pine-fir^b and required number of jack studs)

GIRDERS AND HEADERS SUPPORTING G	SIZ E	GROUND SNOW LOAD (psf) ^e																	
		30						50						70					
		Building width ^c (feet)																	
		12		24		36		12		24		36		12		24		36	
Span f	NJ d	Span f	NJ d	Span f	NJ d	Span f	NJ d	Span f	NJ d	Span f	NJ d	Span f	NJ d	Span f	NJ d	Span f	NJ d		
Roof and ceiling	1- 2x6	4-0	1	3-1	2	2-7	2	3-5	1	2-8	2	2-3	2	3-0	2	2-4	2	2-0	2
	1- 2x8	5-1	2	3-11	2	3-3	2	4-4	2	3-4	2	2-10	2	3-10	2	3-0	2	2-6	3
	1- 2x10	6-0	2	4-8	2	3-11	2	5-2	2	4-0	2	3-4	3	4-7	2	3-6	3	3-0	3
	1- 2x12	7-1	2	5-5	2	4-7	3	6-1	2	4-8	3	3-11	3	5-5	2	4-2	3	3-6	3
	2- 2x4	4-0	1	3-1	1	2-7	1	3-5	1	2-7	1	2-2	1	3-0	1	2-4	1	2-0	1
	2- 2x6	6-0	1	4-7	1	3-10	1	5-1	1	3-11	1	3-3	2	4-6	1	3-6	2	2-11	2
	2- 2x8	7-7	1	5-9	1	4-10	2	6-5	1	5-0	2	4-2	2	5-9	1	4-5	2	3-9	2
	2- 2x10	9-0	1	6-10	2	5-9	2	7-8	2	5-11	2	4-11	2	6-9	2	5-3	2	4-5	2
	2- 2x12	10-7	2	8-1	2	6-10	2	9-0	2	6-11	2	5-10	2	8-0	2	6-2	2	5-2	3
	3- 2x8	9-5	1	7-3	1	6-1	1	8-1	1	6-3	1	5-3	2	7-2	1	5-6	2	4-8	2
	3- 2x10	11-3	1	8-7	1	7-3	2	9-7	1	7-4	2	6-2	2	8-6	1	6-7	2	5-6	2
	3- 2x12	13-2	1	10-1	2	8-6	2	11-3	2	8-8	2	7-4	2	10-0	2	7-9	2	6-6	2
	4- 2x8	10-11	1	8-4	1	7-0	1	9-4	1	7-2	1	6-0	1	8-3	1	6-4	1	5-4	2
	4- 2x10	12-11	1	9-11	1	8-4	1	11-1	1	8-6	1	7-2	2	9-10	1	7-7	2	6-4	2
	4- 2x12	15-3	1	11-8	1	9-10	2	13-0	1	10-0	2	8-5	2	11-7	1	8-11	2	7-6	2
Roof, ceiling and one center-bearing floor	1- 2x6	3-3	1	2-7	2	2-2	2	3-0	2	2-4	2	2-0	2	2-9	2	2-2	2	1-10	2
	1- 2x8	4-1	2	3-3	2	2-9	2	3-9	2	3-0	2	2-6	3	3-6	2	2-9	2	2-4	3
	1- 2x10	4-2	2	3-2	2	3-3	3	4-6	2	3-6	3	3-0	3	4-1	2	3-3	3	2-9	3

	$\frac{2x1}{0}$	<u>11</u>		<u>10</u>															
	$\frac{1-2x1}{2}$	<u>5-9</u>	<u>2</u>	<u>4-6</u>	<u>3</u>	$\frac{3-10}{10}$	<u>3</u>	<u>5-3</u>	<u>2</u>	<u>4-2</u>	<u>3</u>	<u>3-6</u>	<u>3</u>	$\frac{4-10}{10}$	<u>3</u>	$\frac{3-10}{10}$	<u>3</u>	<u>3-3</u>	<u>4</u>
	$\frac{2-2x4}{2}$	<u>3-3</u>	<u>1</u>	<u>2-6</u>	<u>1</u>	<u>2-2</u>	<u>1</u>	<u>3-0</u>	<u>1</u>	<u>2-4</u>	<u>1</u>	<u>2-0</u>	<u>1</u>	<u>2-8</u>	<u>1</u>	<u>2-2</u>	<u>1</u>	$\frac{1-10}{10}$	<u>1</u>
	$\frac{2-2x6}{2}$	$\frac{4-10}{10}$	<u>1</u>	<u>3-9</u>	<u>1</u>	<u>3-3</u>	<u>2</u>	<u>4-5</u>	<u>1</u>	<u>3-6</u>	<u>2</u>	<u>3-0</u>	<u>2</u>	<u>4-1</u>	<u>1</u>	<u>3-3</u>	<u>2</u>	<u>2-9</u>	<u>2</u>
	$\frac{2-2x8}{2}$	<u>6-1</u>	<u>1</u>	$\frac{4-10}{10}$	<u>2</u>	<u>4-1</u>	<u>2</u>	<u>5-7</u>	<u>2</u>	<u>4-5</u>	<u>2</u>	<u>3-9</u>	<u>2</u>	<u>5-2</u>	<u>2</u>	<u>4-1</u>	<u>2</u>	<u>3-6</u>	<u>2</u>
	$\frac{2-2x1}{0}$	<u>7-3</u>	<u>2</u>	<u>5-8</u>	<u>2</u>	$\frac{4-10}{10}$	<u>2</u>	<u>6-8</u>	<u>2</u>	<u>5-3</u>	<u>2</u>	<u>4-5</u>	<u>2</u>	<u>6-1</u>	<u>2</u>	$\frac{4-10}{10}$	<u>2</u>	<u>4-1</u>	<u>2</u>
	$\frac{2-2x1}{2}$	<u>8-6</u>	<u>2</u>	<u>6-8</u>	<u>2</u>	<u>5-8</u>	<u>2</u>	$\frac{7-10}{10}$	<u>2</u>	<u>6-2</u>	<u>2</u>	<u>5-3</u>	<u>3</u>	<u>7-2</u>	<u>2</u>	<u>5-8</u>	<u>2</u>	$\frac{4-10}{10}$	<u>3</u>
	$\frac{3-2x8}{2}$	<u>7-8</u>	<u>1</u>	<u>6-0</u>	<u>1</u>	<u>5-1</u>	<u>2</u>	<u>7-0</u>	<u>1</u>	<u>5-6</u>	<u>2</u>	<u>4-8</u>	<u>2</u>	<u>6-5</u>	<u>1</u>	<u>5-1</u>	<u>2</u>	<u>4-4</u>	<u>2</u>
	$\frac{3-2x1}{0}$	<u>9-1</u>	<u>1</u>	<u>7-2</u>	<u>2</u>	<u>6-1</u>	<u>2</u>	<u>8-4</u>	<u>1</u>	<u>6-7</u>	<u>2</u>	<u>5-7</u>	<u>2</u>	<u>7-8</u>	<u>2</u>	<u>6-1</u>	<u>2</u>	<u>5-2</u>	<u>2</u>
	$\frac{3-2x1}{2}$	$\frac{10-8}{8}$	<u>2</u>	<u>8-5</u>	<u>2</u>	<u>7-2</u>	<u>2</u>	$\frac{9-10}{10}$	<u>2</u>	<u>7-8</u>	<u>2</u>	<u>6-7</u>	<u>2</u>	<u>9-0</u>	<u>2</u>	<u>7-1</u>	<u>2</u>	<u>6-1</u>	<u>2</u>
	$\frac{4-2x8}{2}$	$\frac{8-10}{10}$	<u>1</u>	$\frac{6-11}{11}$	<u>1</u>	$\frac{5-11}{11}$	<u>1</u>	<u>8-1</u>	<u>1</u>	<u>6-4</u>	<u>1</u>	<u>5-5</u>	<u>2</u>	<u>7-5</u>	<u>1</u>	$\frac{5-11}{11}$	<u>1</u>	<u>5-0</u>	<u>2</u>
	$\frac{4-2x1}{0}$	$\frac{10-6}{6}$	<u>1</u>	<u>8-3</u>	<u>2</u>	<u>7-0</u>	<u>2</u>	<u>9-8</u>	<u>1</u>	<u>7-7</u>	<u>2</u>	<u>6-5</u>	<u>2</u>	$\frac{8-10}{10}$	<u>1</u>	<u>7-0</u>	<u>2</u>	<u>6-0</u>	<u>2</u>
	$\frac{4-2x1}{2}$	$\frac{12-4}{4}$	<u>1</u>	<u>9-8</u>	<u>2</u>	<u>8-3</u>	<u>2</u>	$\frac{11-4}{4}$	<u>2</u>	$\frac{8-11}{11}$	<u>2</u>	<u>7-7</u>	<u>2</u>	$\frac{10-4}{4}$	<u>2</u>	<u>8-3</u>	<u>2</u>	<u>7-0</u>	<u>2</u>
Roof, ceiling and one clear span floor	$\frac{1-2x6}{2}$	$\frac{2-11}{11}$	<u>2</u>	<u>2-3</u>	<u>2</u>	$\frac{1-11}{11}$	<u>2</u>	<u>2-9</u>	<u>2</u>	<u>2-1</u>	<u>2</u>	<u>1-9</u>	<u>2</u>	<u>2-7</u>	<u>2</u>	<u>2-0</u>	<u>2</u>	<u>1-8</u>	<u>2</u>
	$\frac{1-2x8}{2}$	<u>3-9</u>	<u>2</u>	$\frac{2-10}{10}$	<u>2</u>	<u>2-5</u>	<u>3</u>	<u>3-6</u>	<u>2</u>	<u>2-8</u>	<u>2</u>	<u>2-3</u>	<u>3</u>	<u>3-3</u>	<u>2</u>	<u>2-6</u>	<u>3</u>	<u>2-2</u>	<u>3</u>
	$\frac{1-2x1}{0}$	<u>4-5</u>	<u>2</u>	<u>3-5</u>	<u>3</u>	$\frac{2-10}{10}$	<u>3</u>	<u>4-2</u>	<u>2</u>	<u>3-2</u>	<u>3</u>	<u>2-8</u>	<u>3</u>	$\frac{3-11}{11}$	<u>2</u>	<u>3-0</u>	<u>3</u>	<u>2-6</u>	<u>3</u>
	$\frac{1-2x1}{2}$	<u>5-2</u>	<u>2</u>	<u>4-0</u>	<u>3</u>	<u>3-4</u>	<u>3</u>	$\frac{4-10}{10}$	<u>3</u>	<u>3-9</u>	<u>3</u>	<u>3-2</u>	<u>4</u>	<u>4-7</u>	<u>3</u>	<u>3-6</u>	<u>3</u>	<u>3-0</u>	<u>4</u>
	$\frac{2-2x4}{2}$	$\frac{2-11}{11}$	<u>1</u>	<u>2-3</u>	<u>1</u>	$\frac{1-10}{10}$	<u>1</u>	<u>2-9</u>	<u>1</u>	<u>2-1</u>	<u>1</u>	<u>1-9</u>	<u>1</u>	<u>2-7</u>	<u>1</u>	<u>2-0</u>	<u>1</u>	<u>1-8</u>	<u>1</u>
	$\frac{2-2x6}{2}$	<u>4-4</u>	<u>1</u>	<u>3-4</u>	<u>2</u>	$\frac{2-10}{10}$	<u>2</u>	<u>4-1</u>	<u>1</u>	<u>3-2</u>	<u>2</u>	<u>2-8</u>	<u>2</u>	$\frac{3-10}{10}$	<u>1</u>	<u>3-0</u>	<u>2</u>	<u>2-6</u>	<u>2</u>
	$\frac{2-2x8}{2}$	<u>5-6</u>	<u>2</u>	<u>4-3</u>	<u>2</u>	<u>3-7</u>	<u>2</u>	<u>5-2</u>	<u>2</u>	<u>4-0</u>	<u>2</u>	<u>3-4</u>	<u>2</u>	$\frac{4-10}{10}$	<u>2</u>	<u>3-9</u>	<u>2</u>	<u>3-2</u>	<u>2</u>
	$\frac{2-2x1}{0}$	<u>6-7</u>	<u>2</u>	<u>5-0</u>	<u>2</u>	<u>4-2</u>	<u>2</u>	<u>6-1</u>	<u>2</u>	<u>4-9</u>	<u>2</u>	<u>4-0</u>	<u>2</u>	<u>5-9</u>	<u>2</u>	<u>4-5</u>	<u>2</u>	<u>3-9</u>	<u>3</u>
	$\frac{2-2x1}{2}$	<u>7-9</u>	<u>2</u>	$\frac{5-11}{11}$	<u>2</u>	$\frac{4-11}{11}$	<u>3</u>	<u>7-2</u>	<u>2</u>	<u>5-7</u>	<u>2</u>	<u>4-8</u>	<u>3</u>	<u>6-9</u>	<u>2</u>	<u>5-3</u>	<u>3</u>	<u>4-5</u>	<u>3</u>

	<u>2</u>																		
	<u>3- 2x8</u>	<u>6- 11</u>	1	<u>5-3</u>	<u>2</u>	<u>4-5</u>	<u>2</u>	<u>6-5</u>	1	<u>5-0</u>	<u>2</u>	<u>4-2</u>	<u>2</u>	<u>6-1</u>	1	<u>4-8</u>	<u>2</u>	<u>4-0</u>	<u>2</u>
	<u>3- 2x1 0</u>	<u>8-3</u>	<u>2</u>	<u>6-3</u>	<u>2</u>	<u>5-3</u>	<u>2</u>	<u>7-8</u>	<u>2</u>	<u>5- 11</u>	<u>2</u>	<u>5-0</u>	<u>2</u>	<u>7-3</u>	<u>2</u>	<u>5-7</u>	<u>2</u>	<u>4-8</u>	<u>2</u>
	<u>3- 2x1 2</u>	<u>9-8</u>	<u>2</u>	<u>7-5</u>	<u>2</u>	<u>6-2</u>	<u>2</u>	<u>9-0</u>	<u>2</u>	<u>7-0</u>	<u>2</u>	<u>5- 10</u>	<u>2</u>	<u>8-6</u>	<u>2</u>	<u>6-7</u>	<u>2</u>	<u>5-6</u>	<u>3</u>
	<u>4- 2x8</u>	<u>8-0</u>	1	<u>6-1</u>	1	<u>5-1</u>	<u>2</u>	<u>7-5</u>	1	<u>5-9</u>	<u>2</u>	<u>4- 10</u>	<u>2</u>	<u>7-0</u>	1	<u>5-5</u>	<u>2</u>	<u>4-7</u>	<u>2</u>
	<u>4- 2x1 0</u>	<u>9-6</u>	1	<u>7-3</u>	<u>2</u>	<u>6-1</u>	<u>2</u>	<u>8- 10</u>	1	<u>6- 10</u>	<u>2</u>	<u>5-9</u>	<u>2</u>	<u>8-4</u>	1	<u>6-5</u>	<u>2</u>	<u>5-5</u>	<u>2</u>
	<u>4- 2x1 2</u>	<u>11- 2</u>	<u>2</u>	<u>8-6</u>	<u>2</u>	<u>7-2</u>	<u>2</u>	<u>10- 5</u>	<u>2</u>	<u>8-0</u>	<u>2</u>	<u>6-9</u>	<u>2</u>	<u>9- 10</u>	<u>2</u>	<u>7-7</u>	<u>2</u>	<u>6-5</u>	<u>2</u>
Roof, ceiling and two center- bearing floors	<u>1- 2x6</u>	<u>2-8</u>	<u>2</u>	<u>2-1</u>	<u>2</u>	<u>1- 10</u>	<u>2</u>	<u>2-7</u>	<u>2</u>	<u>2-0</u>	<u>2</u>	<u>1-9</u>	<u>2</u>	<u>2-5</u>	<u>2</u>	<u>1- 11</u>	<u>2</u>	<u>1-8</u>	<u>2</u>
	<u>1- 2x8</u>	<u>3-5</u>	<u>2</u>	<u>2-8</u>	<u>2</u>	<u>2-4</u>	3	<u>3-3</u>	<u>2</u>	<u>2-7</u>	<u>2</u>	<u>2-2</u>	3	<u>3-1</u>	<u>2</u>	<u>2-5</u>	3	<u>2-1</u>	3
	<u>1- 2x1 0</u>	<u>4-0</u>	<u>2</u>	<u>3-2</u>	3	<u>2-9</u>	3	<u>3- 10</u>	<u>2</u>	<u>3-1</u>	3	<u>2-7</u>	3	<u>3-8</u>	<u>2</u>	<u>2- 11</u>	3	<u>2-5</u>	3
	<u>1- 2x1 2</u>	<u>4-9</u>	3	<u>3-9</u>	3	<u>3-2</u>	4	<u>4-6</u>	3	<u>3-7</u>	3	<u>3-1</u>	4	<u>4-3</u>	3	<u>3-5</u>	3	<u>2- 11</u>	4
	<u>2- 2x4</u>	<u>2-8</u>	1	<u>2-1</u>	1	<u>1-9</u>	1	<u>2-6</u>	1	<u>2-0</u>	1	<u>1-8</u>	1	<u>2-5</u>	1	<u>1- 11</u>	1	<u>1-7</u>	1
	<u>2- 2x6</u>	<u>4-0</u>	1	<u>3-2</u>	<u>2</u>	<u>2-8</u>	<u>2</u>	<u>3-9</u>	1	<u>3-0</u>	<u>2</u>	<u>2-7</u>	<u>2</u>	<u>3-7</u>	1	<u>2- 10</u>	<u>2</u>	<u>2-5</u>	<u>2</u>
	<u>2- 2x8</u>	<u>5-0</u>	<u>2</u>	<u>4-0</u>	<u>2</u>	<u>3-5</u>	<u>2</u>	<u>4- 10</u>	<u>2</u>	<u>3- 10</u>	<u>2</u>	<u>3-3</u>	<u>2</u>	<u>4-7</u>	<u>2</u>	<u>3-7</u>	<u>2</u>	<u>3-1</u>	<u>2</u>
	<u>2- 2x1 0</u>	<u>6-0</u>	<u>2</u>	<u>4-9</u>	<u>2</u>	<u>4-0</u>	<u>2</u>	<u>5-8</u>	<u>2</u>	<u>4-6</u>	<u>2</u>	<u>3- 10</u>	3	<u>5-5</u>	<u>2</u>	<u>4-3</u>	<u>2</u>	<u>3-8</u>	3
	<u>2- 2x1 2</u>	<u>7-0</u>	<u>2</u>	<u>5-7</u>	<u>2</u>	<u>4-9</u>	3	<u>6-8</u>	<u>2</u>	<u>5-4</u>	3	<u>4-6</u>	3	<u>6-4</u>	<u>2</u>	<u>5-0</u>	3	<u>4-3</u>	3
	<u>3- 2x8</u>	<u>6-4</u>	1	<u>5-0</u>	<u>2</u>	<u>4-3</u>	<u>2</u>	<u>6-0</u>	1	<u>4-9</u>	<u>2</u>	<u>4-1</u>	<u>2</u>	<u>5-8</u>	<u>2</u>	<u>4-6</u>	<u>2</u>	<u>3- 10</u>	<u>2</u>
	<u>3- 2x1 0</u>	<u>7-6</u>	<u>2</u>	<u>5- 11</u>	<u>2</u>	<u>5-1</u>	<u>2</u>	<u>7-1</u>	<u>2</u>	<u>5-8</u>	<u>2</u>	<u>4- 10</u>	<u>2</u>	<u>6-9</u>	<u>2</u>	<u>5-4</u>	<u>2</u>	<u>4-7</u>	<u>2</u>
	<u>3- 2x1 2</u>	<u>8- 10</u>	<u>2</u>	<u>7-0</u>	<u>2</u>	<u>5- 11</u>	<u>2</u>	<u>8-5</u>	<u>2</u>	<u>6-8</u>	<u>2</u>	<u>5-8</u>	3	<u>8-0</u>	<u>2</u>	<u>6-4</u>	<u>2</u>	<u>5-4</u>	3
	<u>4- 2x8</u>	<u>7-3</u>	1	<u>5-9</u>	1	<u>4- 11</u>	<u>2</u>	<u>6- 11</u>	1	<u>5-6</u>	<u>2</u>	<u>4-8</u>	<u>2</u>	<u>6-7</u>	1	<u>5-2</u>	<u>2</u>	<u>4-5</u>	<u>2</u>
	<u>4- 2x1 0</u>	<u>8-8</u>	1	<u>6- 10</u>	<u>2</u>	<u>5- 10</u>	<u>2</u>	<u>8-3</u>	<u>2</u>	<u>6-6</u>	<u>2</u>	<u>5-7</u>	<u>2</u>	<u>7- 10</u>	<u>2</u>	<u>6-2</u>	<u>2</u>	<u>5-3</u>	<u>2</u>
	<u>4- 2x1</u>	<u>10- 2</u>	<u>2</u>	<u>8-1</u>	<u>2</u>	<u>6- 10</u>	<u>2</u>	<u>9-8</u>	<u>2</u>	<u>7-8</u>	<u>2</u>	<u>6-7</u>	<u>2</u>	<u>9-2</u>	<u>2</u>	<u>7-3</u>	<u>2</u>	<u>6-2</u>	<u>2</u>

	<u>2</u>																		
Roof, ceiling and two clear span floors	<u>1-2x6</u>	<u>2-3</u>	<u>2</u>	<u>1-9</u>	<u>2</u>	<u>1-5</u>	<u>2</u>	<u>2-3</u>	<u>2</u>	<u>1-9</u>	<u>2</u>	<u>1-5</u>	<u>3</u>	<u>2-2</u>	<u>2</u>	<u>1-8</u>	<u>2</u>	<u>1-5</u>	<u>3</u>
	<u>1-2x8</u>	<u>2-10</u>	<u>2</u>	<u>2-2</u>	<u>3</u>	<u>1-10</u>	<u>3</u>	<u>2-10</u>	<u>2</u>	<u>2-2</u>	<u>3</u>	<u>1-10</u>	<u>3</u>	<u>2-9</u>	<u>2</u>	<u>2-1</u>	<u>3</u>	<u>1-10</u>	<u>3</u>
	<u>1-2x10</u>	<u>3-4</u>	<u>2</u>	<u>2-7</u>	<u>3</u>	<u>2-2</u>	<u>3</u>	<u>3-4</u>	<u>3</u>	<u>2-7</u>	<u>3</u>	<u>2-2</u>	<u>4</u>	<u>3-3</u>	<u>3</u>	<u>2-6</u>	<u>3</u>	<u>2-2</u>	<u>4</u>
	<u>1-2x12</u>	<u>4-0</u>	<u>3</u>	<u>3-0</u>	<u>3</u>	<u>2-7</u>	<u>4</u>	<u>4-0</u>	<u>3</u>	<u>3-0</u>	<u>4</u>	<u>2-7</u>	<u>4</u>	<u>3-10</u>	<u>3</u>	<u>3-0</u>	<u>4</u>	<u>2-6</u>	<u>4</u>
	<u>2-2x4</u>	<u>2-3</u>	<u>1</u>	<u>1-8</u>	<u>1</u>	<u>1-4</u>	<u>1</u>	<u>2-3</u>	<u>1</u>	<u>1-8</u>	<u>1</u>	<u>1-4</u>	<u>1</u>	<u>2-2</u>	<u>1</u>	<u>1-8</u>	<u>1</u>	<u>1-4</u>	<u>2</u>
	<u>2-2x6</u>	<u>3-4</u>	<u>1</u>	<u>2-6</u>	<u>2</u>	<u>2-2</u>	<u>2</u>	<u>3-4</u>	<u>2</u>	<u>2-6</u>	<u>2</u>	<u>2-2</u>	<u>2</u>	<u>3-3</u>	<u>2</u>	<u>2-6</u>	<u>2</u>	<u>2-1</u>	<u>2</u>
	<u>2-2x8</u>	<u>4-3</u>	<u>2</u>	<u>3-3</u>	<u>2</u>	<u>2-8</u>	<u>2</u>	<u>4-3</u>	<u>2</u>	<u>3-3</u>	<u>2</u>	<u>2-8</u>	<u>2</u>	<u>4-1</u>	<u>2</u>	<u>3-2</u>	<u>2</u>	<u>2-8</u>	<u>3</u>
	<u>2-2x10</u>	<u>5-0</u>	<u>2</u>	<u>3-10</u>	<u>2</u>	<u>3-2</u>	<u>3</u>	<u>5-0</u>	<u>2</u>	<u>3-10</u>	<u>2</u>	<u>3-2</u>	<u>3</u>	<u>4-10</u>	<u>2</u>	<u>3-9</u>	<u>3</u>	<u>3-2</u>	<u>3</u>
	<u>2-2x12</u>	<u>5-11</u>	<u>2</u>	<u>4-6</u>	<u>3</u>	<u>3-9</u>	<u>3</u>	<u>5-11</u>	<u>2</u>	<u>4-6</u>	<u>3</u>	<u>3-9</u>	<u>3</u>	<u>5-8</u>	<u>2</u>	<u>4-5</u>	<u>3</u>	<u>3-9</u>	<u>3</u>
	<u>3-2x8</u>	<u>5-3</u>	<u>1</u>	<u>4-0</u>	<u>2</u>	<u>3-5</u>	<u>2</u>	<u>5-3</u>	<u>2</u>	<u>4-0</u>	<u>2</u>	<u>3-5</u>	<u>2</u>	<u>5-1</u>	<u>2</u>	<u>3-11</u>	<u>2</u>	<u>3-4</u>	<u>2</u>
	<u>3-2x10</u>	<u>6-3</u>	<u>2</u>	<u>4-9</u>	<u>2</u>	<u>4-0</u>	<u>2</u>	<u>6-3</u>	<u>2</u>	<u>4-9</u>	<u>2</u>	<u>4-0</u>	<u>2</u>	<u>6-1</u>	<u>2</u>	<u>4-8</u>	<u>2</u>	<u>4-0</u>	<u>3</u>
	<u>3-2x12</u>	<u>7-5</u>	<u>2</u>	<u>5-8</u>	<u>2</u>	<u>4-9</u>	<u>3</u>	<u>7-5</u>	<u>2</u>	<u>5-8</u>	<u>2</u>	<u>4-9</u>	<u>3</u>	<u>7-2</u>	<u>2</u>	<u>5-6</u>	<u>3</u>	<u>4-8</u>	<u>3</u>
	<u>4-2x8</u>	<u>6-1</u>	<u>1</u>	<u>4-8</u>	<u>2</u>	<u>3-11</u>	<u>2</u>	<u>6-1</u>	<u>1</u>	<u>4-8</u>	<u>2</u>	<u>3-11</u>	<u>2</u>	<u>5-11</u>	<u>1</u>	<u>4-7</u>	<u>2</u>	<u>3-10</u>	<u>2</u>
	<u>4-2x10</u>	<u>7-3</u>	<u>2</u>	<u>5-6</u>	<u>2</u>	<u>4-8</u>	<u>2</u>	<u>7-3</u>	<u>2</u>	<u>5-6</u>	<u>2</u>	<u>4-8</u>	<u>2</u>	<u>7-0</u>	<u>2</u>	<u>5-5</u>	<u>2</u>	<u>4-7</u>	<u>2</u>
	<u>4-2x12</u>	<u>8-6</u>	<u>2</u>	<u>6-6</u>	<u>2</u>	<u>5-6</u>	<u>2</u>	<u>8-6</u>	<u>2</u>	<u>6-6</u>	<u>2</u>	<u>5-6</u>	<u>2</u>	<u>8-3</u>	<u>2</u>	<u>6-4</u>	<u>2</u>	<u>5-4</u>	<u>3</u>

For SI: 1 inch = 25.4 mm, 1 pound per square foot = 0.0479 kPa.

- a. Spans are given in feet and inches.
- b. Spans are based on minimum design properties for No. 2 grade lumber of Douglas Fir-Larch, Hem-Fir, Southern Pine, and Spruce-Pine-Fir.
- c. Building width is measured perpendicular to the ridge. For widths between those shown, spans are permitted to be interpolated.
- d. NJ - Number of jack studs required to support each end. Where the number of required jack studs equals one, the header is permitted to be supported by an approved framing anchor attached to the full-height wall stud and to the header.
- e. Use 30 psf ground snow load for cases in which ground snow load is less than 30 psf and the roof live load is equal to or less than 20 psf.
- f. Spans are calculated assuming the top of the header or girder is laterally braced by perpendicular framing. Where the top of the header or girder is not laterally braced (e.g. cripple studs bearing on the header), tabulated spans for headers consisting of 2x8, 2x10, or 2x12 sizes shall be multiplied by 0.70 or the header or girder shall be designed.

Reason: The update of Table R602.7(1) Girder Spans and Header Spans for Exterior Bearing Walls is proposed. Updated spans address use of Southern Pine No. 2 in lieu of Southern Pine No. 1. Footnote "e" is added to clarify that header spans are based on laterally braced assumption such as when the header is raised. For dropped headers consisting of 2x8, 2x10, or 2x12 sizes that are not laterally braced, a factor of 0.7 can be applied to determine the spans or alternatively the header or girder can be designed to include any adjustment for potential buckling. Laterally braced (raised) and not laterally braced (dropped) header

conditions and building widths for which header spans are tabulated represent the same conditions used to develop header span tables in the Wood Frame Construction Manual (WFCM).

Cost Impact: Will increase the cost of construction

Increased cost may be associated with reduced spans that result from the not laterally braced condition and application of footnote f. Due to smaller building width column (12'), permissible use of Southern Pine No. 2, and the laterally braced assumption for tabulated spans, there are also cases where this change will not increase the cost of construction and may reduce cost of construction.

**Report of Committee Action
Hearings**

Committee Action:

Approved as Submitted

Committee Reason: Consistent with prior action on RB226-16. Updates the table to allow No.2 southern pine.

Assembly Action:

None

Final Action Results

RB227-16

AS

Code Change No: **RB228-16**

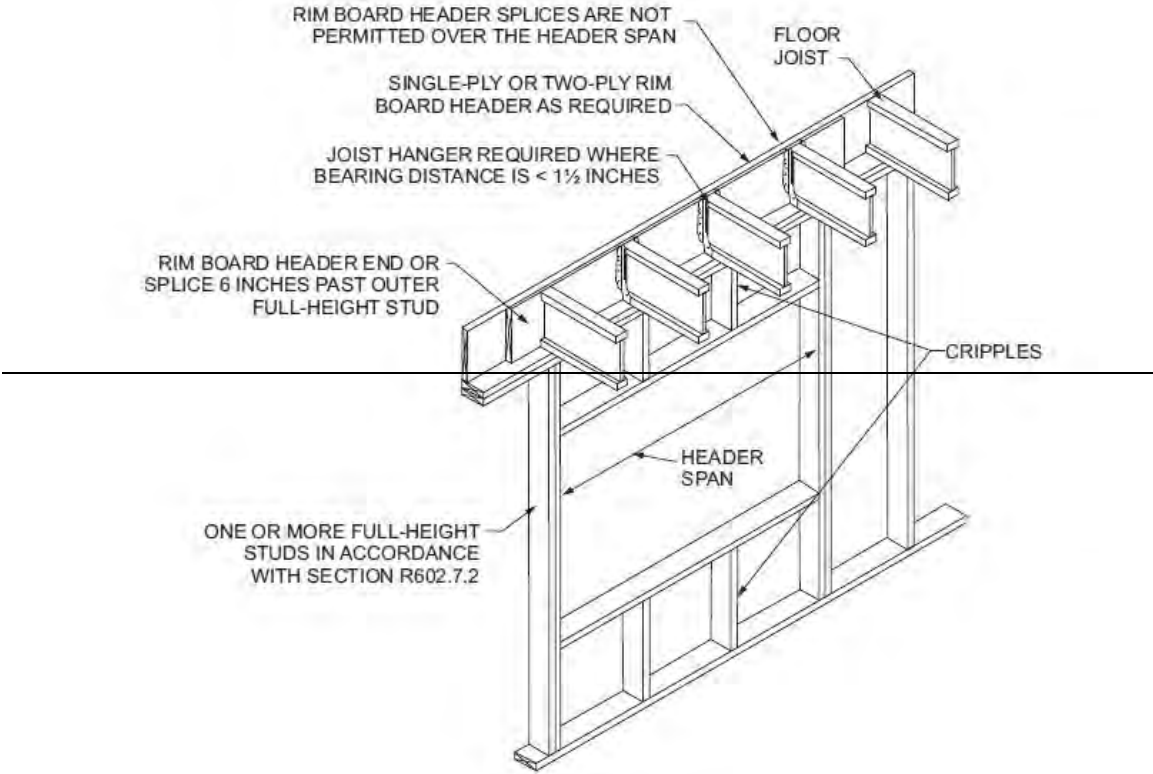
Original Proposal

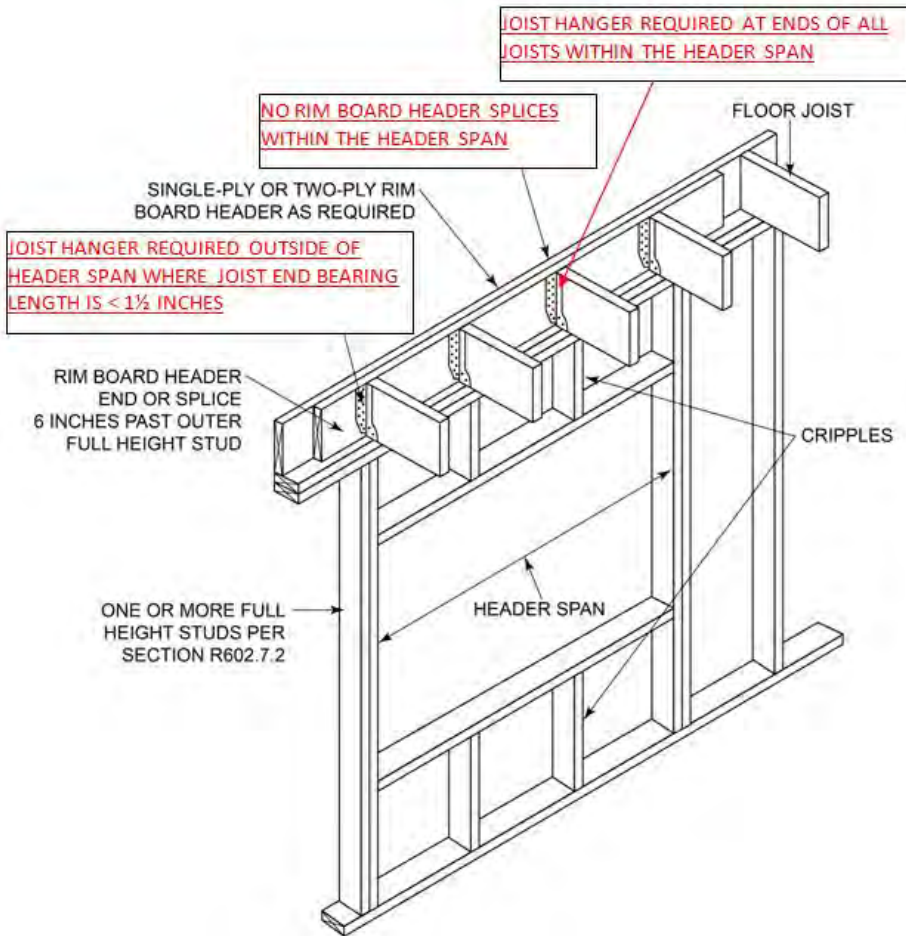
Section: R602.7.2

Proponent: Matthew Hunter, representing American Wood Council (mhunter@awc.org)

Revise as follows:

**FIGURE R602.7.2
RIM BOARD HEADER CONSTRUCTION**





For SI: 25.4 mm = 1 inch.

Reason: This figure revision clarifies requirements for joist hangers in rim board header applications. Joist hangers are always required for attachment of joist to header over the header span to ensure that the load is not transferred to the unsupported portion of the top plate. Joist ends that bear on the portion of the top plate that is directly supported below by full height studs, and with a bearing length of 1.5" or greater, do not require the use of joist hangers.

Cost Impact: Will not increase the cost of construction
 This revision corrects the illustration detail in the previous code edition, and is primarily editorial in nature. Therefore, no increased cost are associated with this change.

Report of Committee Action Hearings

Committee Action: **Approved as Submitted**

Committee Reason: The committee approved this proposal base on the proponents published reason statement.

Assembly Action: **None**

Final Action Results

RB228-16 **AS**

Code Change No: **RB229-16**

Original Proposal

Section: R602.7.5

Proponent: Paul Coats, PE CBO, representing American Wood Council (pcoats@awc.org)

Revise as follows:

R602.7.5 Supports for headers. Headers shall be supported on each end with one or more jack studs or with approved framing anchors in accordance with Table R602.7(1) or R602.7(2). The full-height stud adjacent to each end of the header shall be end nailed to each end of the header with four-16d nails (3.5 inches x 0.135 inches). The minimum number of full-height studs at each end of a header shall be in accordance with Table R602.7.5.

TABLE R602.7.5
MINIMUM NUMBER OF FULL HEIGHT STUDS AT EACH END OF HEADERS IN EXTERIOR WALLS^a

HEADER SPAN- (feet)	MAXIMUM STUD SPACING (inches)- [per Table R602.3(5)]	
	16	24
≤3'	4	4
4'	2	4
8'	3	2
12'	5	3
16'	6	4

MAXIMUM HEADER SPAN (feet)	ULTIMATE DESIGN WIND SPEED AND EXPOSURE CATEGORY	
	< 140 mph, Exposure B or < 130 mph, Exposure C	≤ 115 mph, Exposure B ^b
4	1	1
6	2	1
8	2	1
10	3	2
12	3	2
14	3	2
16	4	2
18	4	2

a. For header spans between those given above, use the minimum number of full-height studs associated with the larger header span.

b. The tabulated minimum number of full-height studs is applicable where jack studs are provided to support the header at each end in accordance with Table R602.7.1(1). Where a framing anchor is used to support the header in lieu of a jack stud in accordance with footnote "d" of Table R602.7.1(1), the minimum number of full-height studs at each end of a header shall be in accordance with requirements for wind speed < 140 mph, Exposure B.

Reason: This change simplifies the full height stud (e.g. king stud) table while also removing conservatism and limited applicability of the 16" maximum stud spacing case. The number of full-height studs is based on out-of-plane wind resistance provided by the stud to plate nailing. The connection resistance has been increased from prior code editions based on RB272-13, approved last cycle. Wind loads are based on an assumption that full-height studs on either side of the opening carry 100% of the out-of-plane wind loads. Reference conditions for the calculations assume a 9' wall height and wall Zone 4 pressures for header spans greater

than 6 feet and wall Zone 5 pressures for header spans less than 6 feet. The number of full height studs required by calculation is limited to the maximum number displaced by the opening. Footnote "a" clarifies that the number of full-height studs for intermediate header spans is based on the next larger header span. Footnote "b" provides a basic assumption of the tabulated requirements-- that headers are supported at each end by jack studs. When jack stud support is not provided, such as when an approved anchor is used in lieu of a jack stud, the full height stud on either side of the opening is carrying both out-of-plane wind loads and gravity loads. For that case, footnote "b" indicates that the < 140 mph Exposure B column associated with the number of studs displaced by the opening is applicable. The reduced number of full-height studs associated with 115 mph Exposure B applies only in those lower wind pressure areas where jack stud support is provided to the header at each end.

Cost Impact: Will not increase the cost of construction

The proposed table will require less full-height studs than are currently required in some circumstances, and will never require more than are currently required. Therefore the cost of construction will not increase.

Report of Committee Action Hearings
--

Committee Action:

Approved as Submitted

Committee Reason: The committee approved this proposal based on the proponents published reason statement. The column headers should be reversed with ≤ 115 mph on the left and the right hand side should show > 115 mph but less than 140 mph, Exposure B or 130 mph, Exposure C.

Assembly Action:

None

Final Action Results

RB229-16

AS

Code Change No: **RB230-16**

Original Proposal

Section: R602, R602.10.10, R602.10.3

Proponent: Charles Bajnai, representing Chesterfield County, VA (bajnaic@chesterfield.gov); Bradford Douglas (bdouglas@awc.org); Gary Ehrlich (gehrlich@nahb.org)

Revise as follow:

TABLE R602.10.3 (2)
WIND ADJUSTMENT FACTORS TO THE REQUIRED LENGTH OF WALL BRACING

ITEM NUMBER	ADJUSTMENT BASED ON	STORY/SUPPORTING	CONDITION	ADJUSTMENT FACTOR ^{a, b} [multiply length from Table R602.10.3(1) by this factor]	APPLICABLE METHODS
1	Exposure category	One-story structure	B	1.00	All methods
			C	1.20	
			D	1.50	
		Two-story structure	B	1.00	
			C	1.30	
			D	1.60	
		Three-story structure	B	1.00	
			C	1.40	
			D	1.70	
2	Roof eave-to-ridge height	Roof only	≤ 5 feet	0.70	
			10 feet	1.00	
			15 feet	1.30	
			20 feet	1.60	
		Roof + 1 floor	≤ 5 feet	0.85	
			10 feet	1.00	
			15 feet	1.15	
			20 feet	1.30	
		Roof + 2 floors	≤ 5 feet	0.90	
			10 feet	1.00	
			15 feet	1.10	
			20 feet	Not permitted	
3	Wall height adjustment	Any story	8 feet	0.90	
			9 feet	0.95	
			10 feet	1.00	
			11 feet	1.05	
			12 feet	1.10	
4	Number of braced wall lines (per plan)	Any story	2	1.00	
			3	1.30	
			4	1.45	

	direction) ^c		≥ 5	1.60	
5	Additional 800-pound hold-down device	Top story only	Fastened to the end studs of each braced wall panel and to the foundation or framing below	0.80	DWB, WSP, SFB, PBS, PCP, HPS
6	Interior gypsum board finish (or equivalent)	Any story	Omitted from inside face of braced wall panels	1.40	DWB, WSP, SFB, PBS, PCP, HPS, CS- WSP, CS-G, CS-SFB
7	Gypsum board fastening	Any story	4 inches o.c. at panel edges, including top and bottom plates, and all horizontal joints blocked	0.7	GB
8	<u>Horizontal blocking</u>	<u>Any story</u>	<u>Horizontal blocking is omitted.</u>	<u>2.0</u>	<u>WSP, CS-WSP</u>


For SI: 1 inch = 25.4 mm, 1 foot = 304.8 mm, 1 pound = 4.48 N.



a. Linear interpolation shall be permitted.

b. The total adjustment factor is the product of all applicable adjustment factors.

c. The adjustment factor is permitted to be 1.0 when determining bracing amounts for intermediate braced wall lines provided the bracing amounts on adjacent braced wall lines are based on a spacing and number that neglects the intermediate braced wall line.

TABLE R602.10.3 (4)
SEISMIC ADJUSTMENT FACTORS TO THE REQUIRED LENGTH OF WALL BRACING

ITEM NUMBER	ADJUSTMENT BASED ON:	STORY	CONDITION	ADJUSTMENT FACTOR ^{a, b} [Multiply length from Table R602.10.3(3) by this factor]	APPLICABLE METHODS
1	Story height (Section 301.3)	Any story	≤ 10 feet	1.0	All methods
			> 10 feet and ≤ 12 feet	1.2	
2	Braced wall line spacing, townhouses in SDC C	Any story	≤ 35 feet	1.0	
			> 35 feet and ≤ 50 feet	1.43	
3	Braced wall line spacing, in SDC D ₀ , D ₁ , D ₂ ^c	Any story	> 25 feet and ≤ 30 feet	1.2	
			> 30 feet and ≤ 35 feet	1.4	
4	Wall dead load	Any story	> 8 psf and < 15 psf	1.0	
			< 8 psf	0.85	
5	Roof/ceiling dead load for wall supporting	1-, 2- or 3-story building	≤ 15 psf	1.0	
		2- or 3-story building	> 15 psf and ≤ 25 psf	1.1	
		1-story building	> 15 psf and ≤ 25 psf	1.2	
6	Walls with stone or masonry veneer, townhouses in		1.0	All methods	

	SDC C ^{d, e}		1.5		
			1.5		
7	Walls with stone or masonry veneer, detached one- and two-family dwellings in SDC D ₀ – D ₂ ^{d, f}	Any story	See Table R602.10.6.5	BV-WSP	
8	Interior gypsum board finish (or equivalent)	Any story	Omitted from inside face of braced wall panels	1.5	DWB, WSP, SFB, PBS, PCP, HPS, CS-WSP, CS-G, CS-SFB
<u>9</u>	<u>Horizontal blocking</u>	<u>Any story</u>	<u>Horizontal blocking is omitted.</u>	<u>2.0</u>	<u>WSP, CS-WSP</u>

For SI: 1 foot = 304.8 mm, 1 pound per square foot = 0.0479 kPa.

- a. Linear interpolation shall be permitted.
- b. The total length of bracing required for a given wall line is the product of all applicable adjustment factors.
- c. The length-to-width ratio for the floor/roof *diaphragm* shall not exceed 3:1. The top plate lap splice nailing shall be in accordance with Table R602.3(1), Item 13.
- d. Applies to stone or masonry veneer exceeding the first story height.
- e. The adjustment factor for stone or masonry veneer shall be applied to all exterior *braced wall lines* and all *braced wall lines* on the interior of the building, backing or perpendicular to and laterally supported veneered walls.
- f. See Section R602.10.6.5 for requirements where stone or masonry veneer does not exceed the first-story height.

R602.10.4 R602.10.4.4 Panel joints. Vertical joints of panel sheathing shall occur over, and be fastened to, common studs. Horizontal joints of panel sheathing in *braced wall panels* shall occur over, and be fastened to, common blocking of a minimum 1 1/2 inch (38 mm) thickness.

Exceptions:

1. ~~Vertical joints of panel sheathing shall be permitted to occur over double studs, where adjoining panel edges are attached to separate studs with the required panel edge fastening schedule, and the adjacent studs are attached together with two rows of 10d box nails [3 inches by 0.128 inch (76.2 mm by 3.25 mm)] at 10 inches o.c. (254 mm). For methods WSP and CS-WSP, blocking of horizontal joints is permitted to be omitted when adjustment factor number 8 of Table R602.10.3(2) or number 9 of Table R602.3(4) is applied.~~

2. ~~Blocking at horizontal joints shall not be required in wall segments that are not counted as braced wall panels.~~
3. ~~Where the bracing length provided is not less than twice the minimum length required by Tables R602.10.3(1) and R602.10.3(3), blocking at horizontal joints shall not be required in braced wall panels constructed using Methods WSP, SFB, GB, PBS or HPS.~~
4. ~~Where Method GB panels are installed horizontally, blocking of horizontal joints is not required.~~
5. For methods WSP and CS-WSP, blocking of horizontal joints is permitted to be omitted when adjustment factor number 8 of Table R602.10.3(2) or number 9 of Table R602.3(4) is applied.
6. Vertical joints of panel sheathing shall be permitted to occur over double studs, where adjoining panel edges are attached to separate studs with the required panel edge fastening schedule, and the adjacent studs are attached together with two rows of 10d box nails [3 inches by 0.128 inch (76.2 mm by 3.25 mm)] at 10 inches o.c. (254 mm).
7. Blocking at horizontal joints shall not be required in wall segments that are not counted as braced wall panels.
8. Where Method GB panels are installed horizontally, blocking of horizontal joints is not required.

Reason:

WHAT: This code change proposal is intended to move requirements for construction of braced wall panels in R602.10.10 and move it to the section on construction methods for braced wall panels in R602.10.4, and move an existing bracing amount correction from R602.10.10 (exception #3) into the Adjustment Factor Tables, R602.10.3(2) for wind and R602.10.3(4) for seismic.

WHY: Several members of the past ICC Ad Hoc Wall Bracing committee discussed this issue and agreed that the existing language is confusing and that it made sense to move this this correction factor into the tables with all of the other adjustment factors.

Currently this adjustment factor for horizontal blocking is virtually lost because it is near the end of the wall bracing section. While discussing the issue, it became apparent to the members that there were some wrong materials listed in R602.10.10. Revisions of the panels that are permitted to omit horizontal blocking is based on the shear wall provisions of the AWC Special Design Provisions for Wind and Seismic (2015 SDPWS). That document is the code-referenced standard for design of shearwalls, and it permits unblocked WSP shearwalls only if the capacity is reduced by half. For SFB and PB shear walls, all panel edges are required to be blocked. Data was submitted to the ICC Ad Hoc Wall Bracing Committee regarding no reduction for horizontal gypsum board. Since SFB, vertical GB and HPS are not permitted to be unblocked, they were eliminated from the table.

Bibliography: Special Design Provisions for Wood Construction (ANSI/AWC SDPWS-2015), American Wood Council, 2015 www.awc.org

Cost Impact: Will not increase the cost of construction

This code should not increase the cost of construction.

Under the 2015 IRC, it is possible that if the bracing amount is doubled, then blocking could be omitted for SFB, vertical GB, or HPS. This option will not be available if this proposal is approved. But the cost of the blocking is far less than the cost of doubling the bracing amount so there should be no cost increase.

**Report of Committee Action
Hearings**
Committee Action:**Approved as Modified****Modify as follows:**

R602.10.4.4 Panel joints. Vertical joints of panel sheathing shall occur over, and be fastened to, common studs. Horizontal joints of panel sheathing in *braced wall panels* shall occur over, and be fastened to, common blocking of a minimum 1¹/₂ inch (38 mm) thickness.

Exceptions:

1. For methods WSP and CS-WSP, blocking of horizontal joints is permitted to be omitted when adjustment factor number 8 of Table R602.10.3(2) or number 9 of Table ~~R602.3(4)~~ R602.10.3(4) is applied.
2. Vertical joints of panel sheathing shall be permitted to occur over double studs, where adjoining panel edges are attached to separate studs with the required panel edge fastening schedule, and the adjacent studs are attached together with two rows of 10d box nails [3 inches by 0.128 inch (76.2 mm by 3.25 mm)] at 10 inches o.c. (254 mm).
3. Blocking at horizontal joints shall not be required in wall segments that are not counted as *braced wall panels*.
4. Where Method GB panels are installed horizontally, blocking of horizontal joints is not required.

Committee Reason: This changes moves the adjustment factor for the absence of horizontal blocking into the wind and seismic adjustment factor table where it belongs. The modification corrects the reference table number in exception 1.

Assembly Action

None

Final Action Results

RB230-16

AM

Code Change No: **RB231-16**

Original Proposal

Section: R602, R602.10.3

Proponent: Charles Bajnai, representing Chesterfield County, VA and Virginia Building Code Officials Association (VBCOA) (bajnaic@chesterfield.gov)

Revise as follows:

TABLE R602.10.3(2)
WIND ADJUSTMENT FACTORS TO THE REQUIRED LENGTH OF WALL BRACING

ITEM NUMBER	ADJUSTMENT BASED ON	STORY/SUPPORTING	CONDITION	ADJUSTMENT FACTOR ^a ^b [multiply length from Table R602.10.3(1) by this factor]	APPLICABLE METHODS
1	Exposure category ^d	One-story structure	B	1.00	All methods
			C	1.20	
			D	1.50	
		Two-story structure	B	1.00	
			C	1.30	
			D	1.60	
		Three-story structure	B	1.00	
			C	1.40	
			D	1.70	
2	Roof eave-to-ridge height	Roof only	≤ 5 feet	0.70	
			10 feet	1.00	
			15 feet	1.30	
			20 feet	1.60	
		Roof + 1 floor	≤ 5 feet	0.85	
			10 feet	1.00	
			15 feet	1.15	
			20 feet	1.30	
		Roof + 2 floors	≤ 5 feet	0.90	
			10 feet	1.00	

			15 feet	1.10	
			20 feet	Not permitted	
3	Wall height adjustment	Any story	8 feet	0.90	
			9 feet	0.95	
			10 feet	1.00	
			11 feet	1.05	
			12 feet	1.10	
4	Number of braced wall lines (per plan direction) ^c	Any story	2	1.00	
			3	1.30	
			4	1.45	
			≥ 5	1.60	
5	Additional 800-pound hold-down device	Top story only	Fastened to the end studs of each braced wall panel and to the foundation or framing below	0.80	DWB, WSP, SFB, PBS, PCP, HPS
6	Interior gypsum board finish (or equivalent)	Any story	Omitted from inside face of braced wall panels	1.40	DWB, WSP, SFB, PBS, PCP, HPS, CS- WSP, CS-G, CS-SFB
7	Gypsum board fastening	Any story	4 inches o.c. at panel edges, including top and bottom plates, and all horizontal joints blocked	0.7	GB

For SI: 1 inch = 25.4 mm, 1 foot = 304.8 mm, 1 pound = 4.48 N.







- a. Linear interpolation shall be permitted.
- b. The total adjustment factor is the product of all applicable adjustment factors.
- c. The adjustment factor is permitted to be 1.0 when determining bracing amounts for intermediate braced wall lines provided the bracing amounts on adjacent braced wall lines are based on a spacing and number that neglects the intermediate braced wall line.
- d. The same adjustment factor shall be applied to all braced wall lines on all floors of the structure, based on worst case exposure category.

Reason: ICC staff requested an unofficial interpretation from the past ICC Ad Hoc Wall Bracing Committee regarding how the adjustment factor for Exposure Category applied. The new footnote has been vetted by several of the past members and is being submitted to clarify the intent.

Concurrently, icons have been added to further clarify the intention of both the exposure category and the eave-to-ridge height.

TABLE R602.10.3(2)

WIND ADJUSTMENT FACTORS TO THE REQUIRED LENGTH OF WALL BRACING

ITEM NUMBER	ADJUSTMENT BASED ON	STORY/SUPPORTING	CONDITION	ADJUSTMENT FACTOR	APPLICABLE METHOD
1	Exposure category ^d	One story structure 	B	1.00	
			C	1.20	
			D	1.50	
		Two-story structure 	B	1.00	
			C	1.30	
			D	1.60	
		Three-story structure 	B	1.00	
			C	1.40	
			D	1.70	
2	Roof eave-to-ridge height	Roof only 	≤ 5 feet	.70	
			10 feet	1.00	
			15 feet	1.30	
			20 feet	1.60	
		Roof + 1 floor 	≤ 5 feet	.85	
			10 feet	1.00	
			15 feet	1.15	
			20 feet	1.60	
		Roof + 2 floors 	≤ 5 feet	.90	
			10 feet	1.00	
			15 feet	1.10	
			20 feet	Not permitted	

Report of Committee Action Hearings

Committee Action:

Approved as Submitted

Committee Reason: The added footnote clarifies how to apply the adjustment factor for Exposure Category when there are multiple categories on the site.

Assembly Action:

None

Final Action Results

RB231-16

AS

Code Change No: **RB233-16**

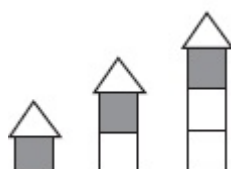

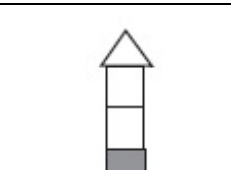

Original Proposal



Section: R602.10.3

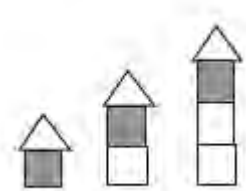
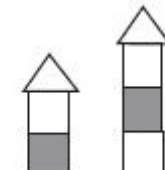


Proponent: Edward Keith, representing APA- The Engineered Wood Association
(ed.keith@apawood.org)

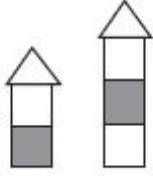
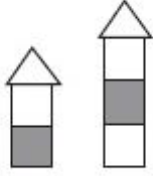

Revise as follows:

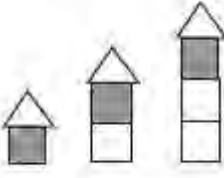
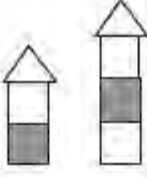

TABLE R602.10.3 (1)
BRACING REQUIREMENTS BASED ON WIND SPEED

· EXPOSURE CATEGORY B · 30-FOOT MEAN ROOF HEIGHT · 10-FOOT WALL HEIGHT · 2 BRACED WALL LINES			MINIMUM TOTAL LENGTH (FEET) OF BRACED WALL PANELS REQUIRED ALONG EACH BRACED WALL LINE ^a			
Ultimate Design Wind Speed (mph)	Story Location	Braced Wall Line Spacing ^c (feet)	Method LIB ^b	Method GB	Methods DWB, WSP, SFB, PBS, PCP, HPS, BV-WSP, ABW, PFH, PFC, CS-SFB ^e	Methods CS-WSP, CS-G, CS-PF
≤110		10	3.5	3.5	2.0	1.5
		20	6.0	6.0	3.5	3.0
		30	8.5	8.5	5.0	4.5
		40	11.5	11.5	6.5	5.5
		50	14.0	14.0	8.0	7.0
		60	16.5	16.5	9.5	8.0
		10	6.5	6.5	3.5	3.0
		20	11.5	11.5	6.5	5.5
		30	16.5	16.5	9.5	8.0
		40	21.5	21.5	12.5	10.5
		50	26.5	26.5	15.5	13.0
		60	31.5	31.5	18.0	15.5
		10	NP	9.5	5.5	4.5
		20	NP	17.0	10.0	8.5
		30	NP	24.5	14.0	12.0
		40	NP	32.0	18.5	15.5
		50	NP	39.5	22.5	19.0
		60	NP	46.5	26.5	23.0
≤ 115		10	3.5	3.5	2.0	2.0
		20	6.5	6.5	3.5	3.5
		30	9.5	9.5	5.5	4.5
		40	12.5	12.5	7.0	6.0
		50	15.0	15.0	9.0	7.5
		60	18.0	18.0	10.5	9.0

	10	7.0	7.0	4.0	3.5	
	20	12.5	12.5	7.5	6.5	
	30	18.0	18.0	10.5	9.0	
	40	23.5	23.5	13.5	11.5	
	50	29.0	29.0	16.5	14.0	
	60	34.5	34.5	20.0	17.0	
		10	NP	10.0	6.0	5.0
		20	NP	18.5	11.0	9.0
		30	NP	27.0	15.5	13.0
		40	NP	35.0	20.0	17.0
		50	NP	43.0	24.5	21.0
		60	NP	51.0	29.0	25.0

· EXPOSURE CATEGORY B · 30-FOOT MEAN ROOF HEIGHT · 10-FOOT WALL HEIGHT · 2 BRACED WALL LINES			MINIMUM TOTAL LENGTH (FEET) OF BRACED WALL PANELS REQUIRED ALONG EACH BRACED WALL LINE ^a			
Ultimate Design Wind Speed (mph)	Story Location	Braced Wall Line Spacing (feet)	Method LIB ^b	Method GB	Methods DWB, WSP, SFB, PBS, PCP, HPS, BV-WSP, ABW, PFH, PFG, CS-SFB ^c	Methods CS-WSP, CS-G, CS-PF
≤ 120		10	4.0	4.0	2.5	2.0
		20	7.0	7.0	4.0	3.5
		30	10.5	10.5	6.0	5.0
		40	13.5	13.5	8.0	6.5
		50	16.5	16.5	9.5	8.0
		60	19.5	19.5	11.5	9.5
		10	7.5	7.5	4.5	3.5
		20	14.0	14.0	8.0	7.0
		30	20.0	20.0	11.5	9.5
		40	25.5	25.5	15.0	12.5
		50	31.5	31.5	18.0	15.5
		60	37.5	37.5	21.5	18.5
		10	NP	11.0	6.5	5.5
		20	NP	20.5	11.5	10.0
		30	NP	29.0	17.0	14.5
		40	NP	38.0	22.0	18.5
		50	NP	47.0	27.0	23.0
		60	NP	55.5	32.0	27.0
≤ 130		10	4.5	4.5	2.5	2.5
		20	8.5	8.5	5.0	4.0

	30	12.0	12.0	7.0	6.0	
	40	15.5	15.5	9.0	7.5	
	50	19.5	19.5	11.0	9.5	
	60	23.0	23.0	13.0	11.0	
		10	8.5	8.5	5.0	4.5
		20	16.0	16.0	9.5	8.0
		30	23.0	23.0	13.5	11.5
		40	30.0	30.0	17.5	15.0
		50	37.0	37.0	21.5	18.0
		60	44.0	44.0	25.0	21.5
		10	NP	13.0	7.5	6.5
		20	NP	24.0	13.5	11.5
		30	NP	34.5	19.5	17.0
		40	NP	44.5	25.5	22.0
		50	NP	55.0	31.5	26.5
	60	NP	65.0	37.5	31.5	

· EXPOSURE CATEGORY B · 30-FOOT MEAN ROOF HEIGHT · 10-FOOT WALL HEIGHT · 2 BRACED WALL LINES			MINIMUM TOTAL LENGTH (FEET) OF BRACED WALL PANELS REQUIRED ALONG EACH BRACED WALL LINE ^a			
Ultimate Design Wind Speed (mph)	Story Location	Braced Wall Line Spacing (feet)	Method LIB ^b	Method GB	Methods DWB, WSP, SFB, PBS, PCP, HPS, BV-WSP, ABW, PFH, PFG, CS-SFB ^c	Methods CS-WSP, CS-G, CS-PF
≤ 140		10	5.5	5.5	3.0	2.5
		20	10.0	10.0	5.5	5.0
		30	14.0	14.0	8.0	7.0
		40	18.0	18.0	10.5	9.0
		50	22.5	22.5	13.0	11.0
		60	26.5	26.5	15.0	13.0
		10	10.0	10.0	6.0	5.0
		20	18.5	18.5	11.0	9.0
		30	27.0	27.0	15.5	13.0
		40	35.0	35.0	20.0	17.0
		50	43.0	43.0	24.5	21.0
		60	51.0	51.0	29.0	25.0
		10	NP	15.0	8.5	7.5
		20	NP	27.5	16.0	13.5

		30	NP	39.5	23.0	19.5
		40	NP	51.5	29.5	25.0
		50	NP	63.5	36.5	31.0
		60	NP	75.5	43.0	36.5

For SI: 1 inch = 25.4 mm, 1 foot = 304.8 mm, 1 mile per hour = 0.447 m/s.

- a. Linear interpolation shall be permitted.
- b. Method LIB shall have gypsum board fastened to not less than one side with nails or screws in accordance with Table R602.3(1) for exterior sheathing or Table R702.3.5 for interior gypsum board. Spacing of fasteners at panel edges shall not exceed 8 inches.
- c. Where a braced wall line has three or more parallel braced wall lines on one or both sides of differing dimensions are present and the distances between adjacent braced wall lines are different, the average dimension shall be permitted to be used for braced wall line spacing.

Reason: The callout for Footnote (c) was inadvertently left off of the table. This proposal places it in the table in the appropriate location.

As Footnote (c) is currently written, it is unclear that the "differing dimensions" discussed are the distance between braced wall lines and not braced wall line lengths. In addition, for differing distances between braced wall lines to be possible, there must be at least 3 parallel braced wall lines. As such it is not possible for this to be true if the parallel braced wall line exists only on "one side". The proposed language corrects this possible point of confusion while it more clearly states the intent of the provision.

Cost Impact: Will not increase the cost of construction
 This code changes has no impact on the cost of construction. It clarifies the original intent of the Code.

Report of Committee Action Hearings

Committee Action:

Approved as Submitted

Committee Reason: The committee approved this proposal based on the proponents published reason statement. Also, due to an error in the submittal process the superscript c should be shown added to the 3rd column in three places and deleted from the 6th column in three places.

Assembly Action:

None

Final Action Results

RB233-16

AS

Code Change No: **RB234-16**

Original Proposal

Section: R602.10.3

Proponent: Edward Keith, representing APA- The Engineered Wood Association (ed.keith@apawood.org)

Revise as follow:

TABLE R602.10.3 (2)
WIND ADJUSTMENT FACTORS TO THE REQUIRED LENGTH OF WALL BRACING

ITEM NUMBER	ADJUSTMENT BASED ON	STORY/SUPPORTING	CONDITION	ADJUSTMENT FACTOR ^a ^b [multiply length from Table R602.10.3(1) by this factor]	APPLICABLE METHODS
1	Exposure category	One-story structure	B	1.00	All methods
			C	1.20	
			D	1.50	
		Two-story structure	B	1.00	
			C	1.30	
			D	1.60	
		Three-story structure	B	1.00	
			C	1.40	
			D	1.70	
2	Roof eave-to-ridge height	Roof only	≤ 5 feet	0.70	
			10 feet	1.00	
			15 feet	1.30	
			20 feet	1.60	
		Roof + 1 floor	≤ 5 feet	0.85	
			10 feet	1.00	
			15 feet	1.15	
			20 feet	1.30	
		Roof + 2 floors	≤ 5 feet	0.90	
			10 feet	1.00	
			15 feet	1.10	
			20 feet	Not permitted	
3	Wall <u>Story height adjustment</u> (R301.3)	Any story	8 feet	0.90	
			9 feet	0.95	
			10 feet	1.00	
			11 feet	1.05	
			<u>12 feet 11 feet – 7 inches</u>	<u>1.10</u>	
4	Number of braced wall lines (per plan)	Any story	2	1.00	

ITEM NUMBER	ADJUSTMENT BASED ON	STORY/SUPPORTING	CONDITION	ADJUSTMENT FACTOR ^a ^b [multiply length from Table R602.10.3(1) by this factor]	APPLICABLE METHODS
	direction) ^c		3	1.30	
			4	1.45	
			≥ 5	1.60	
5	Additional 800-pound hold-down device	Top story only	Fastened to the end studs of each braced wall panel and to the foundation or framing below	0.80	DWB, WSP, SFB, PBS, PCP, HPS
6	Interior gypsum board finish (or equivalent)	Any story	Omitted from inside face of braced wall panels	1.40	DWB, WSP, SFB, PBS, PCP, HPS, CS-WSP, CS-G, CS-SFB
7	Gypsum board fastening	Any story	4 inches o.c. at panel edges, including top and bottom plates, and all horizontal joints blocked	0.7	GB

For SI: 1 inch = 25.4 mm, 1 foot = 304.8 mm, 1 pound = 4.48 N.

a. Linear interpolation shall be permitted.

b. The total adjustment factor is the product of all applicable adjustment factors.

c. The adjustment factor is permitted to be 1.0 when determining bracing amounts for intermediate braced wall lines provided the bracing amounts on adjacent braced wall lines are based on a spacing and number that neglects the intermediate braced wall line.

Reason: In the 2015 edition of the IRC, changes were made to Section R301.3 that shifted the emphasis from wall height to story height. As a result, there is no limitation on wall height as long as the story height does not exceed 11'-7". As a result of this change, the terminology used in the wall bracing adjustment tables (Tables R602.10.3(2) and R602.10.3(4)) was reevaluated. In reviewing these tables, it was found that the seismic adjustment table (Table R602.10.3(4)) was already written in terms of "story height." However, the wind adjustment table (Table R602.10.3(2)) in item 3 shown above still referenced "wall height". The proposed change does three things. It first makes the adjustment based on story height to put it in line with the seismic adjustment table as well as Section R301.3. Secondly, it limits the story height to 11'-7" per Section R301.3 and the new corresponding adjustment factor was interpolated based on the existing values for the adjustment factors for 11 and 12 feet. The third proposed change is to format the "ADJUSTMENT BASED ON" cell as it is in the seismic adjustment table (Table R602.10.3(4)) to make the two adjustment tables more consistent and easier for the user.

It is important to note that in the development of the current bracing provisions, one of the basic principles that was adopted by the ICC Bracing Committee was that the unadjusted bracing provisions were good up to 10 feet and heights above that were to be adjusted accordingly. What was not consistent was whether the 10 feet was a wall height or story height. The above change makes the two adjustment tables identical in how to treat story height and makes the adjustment for a 10 ft story height equal to 1.00 for both wind and seismic. This should make the 2018 IRC consistent throughout with the intent of the provisions adopted during the 2015 cycle.

We ask the committee to accept these changes to make the bracing provisions consistent throughout the various sections of the IRC and less subject to incorrect interpretation.

Cost Impact: Will not increase the cost of construction

This code change will not increase the cost of construction as it clarifies the intent of the original code provisions.

Report of Committee Action Hearings
--

Committee Action:

Approved as Modified

Modify as follows:

**TABLE R602.10.3 (2)
WIND ADJUSTMENT FACTORS TO THE REQUIRED LENGTH OF WALL BRACING**

ITEM NUMBER	ADJUSTMENT BASED ON	STORY/SUPPORTING	CONDITION	ADJUSTMENT FACTOR ^{a, b} [multiply length from Table R602.10.3(1) by this factor]	APPLICABLE METHODS
1	Exposure category	One-story structure	B	1.00	All methods
			C	1.20	
			D	1.50	
		Two-story structure	B	1.00	
			C	1.30	
			D	1.60	
		Three-story structure	B	1.00	
			C	1.40	
			D	1.70	
2	Roof eave-to-ridge height	Roof only	≤ 5 feet	0.70	
			10 feet	1.00	
			15 feet	1.30	
			20 feet	1.60	
		Roof + 1 floor	≤ 5 feet	0.85	
			10 feet	1.00	
			15 feet	1.15	
			20 feet	1.30	
		Roof + 2 floors	≤ 5 feet	0.90	
			10 feet	1.00	
			15 feet	1.10	

			20 feet	Not permitted	
3	Story height (R301.3)	Any story	8 feet	0.90	
			9 feet	0.95	
			10 feet	1.00	
			11 feet	1.05	
			12 feet 11 feet — 7 inches	1.10 1.08	
4	Number of braced wall lines (per plan direction) ^c	Any story	2	1.00	
			3	1.30	
			4	1.45	
			≥ 5	1.60	
5	Additional 800-pound hold-down device	Top story only	Fastened to the end studs of each braced wall panel and to the foundation or framing below	0.80	DWB, WSP, SFB, PBS, PCP, HPS
6	Interior gypsum board finish (or equivalent)	Any story	Omitted from inside face of braced wall panels	1.40	DWB, WSP, SFB, PBS, PCP, HPS, CS- WSP, CS-G, CS-SFB
7	Gypsum board fastening	Any story	4 inches o.c. at panel edges, including top and bottom plates, and all horizontal joints blocked	0.7	GB

For SI: 1 inch = 25.4 mm, 1 foot = 304.8 mm, 1 pound = 4.48 N.

a. Linear interpolation shall be permitted.

b. The total adjustment factor is the product of all applicable adjustment factors.

c. The adjustment factor is permitted to be 1.0 when determining bracing amounts for intermediate braced wall lines provided the bracing amounts on adjacent braced wall lines are based on a spacing and number that neglects the intermediate braced wall line.

Committee Reason: This change provides consistency with the seismic bracing table and Section R301.3 as regards the story height. The modification reverts the story height and adjustment factor back to the original 12 feet to be consistent with prior committee action.

Assembly Action

None

Final Action Results

RB234-16

AM

Code Change No: **RB235-16**

Original Proposal

Section(s): R602.10.3, R602.10.4.1

Proponent: Edward Keith, representing APA- The Engineered Wood Association
(ed.keith@apawood.org)

Revise as follows:

TABLE R602.10.3 (3)
BRACING REQUIREMENTS BASED ON SEISMIC DESIGN CATEGORY

· SOIL CLASS D ^d · WALL HEIGHT = 10 FEET · 10 PSF FLOOR DEAD LOAD · 15 PSF ROOF/CEILING DEAD LOAD · BRACED WALL LINE SPACING ≤ 25 FEET			MINIMUM TOTAL LENGTH (FEET) OF BRACED WALL PANELS REQUIRED ALONG EACH BRACED WALL LINE ^{a,f}				
Seismic Design Category	Story Location	Braced Wall Line Length (feet) ^c	Method LIB ^d	Method GB	Methods DWB, SFB, PBS, PCP, HPS, CS-SFB ^e	Method WSP	Methods CS-WSP, CS-G, CS-PF
C (townhouses only)		10	2.5	2.5	2.5	1.6	1.4
		20	5.0	5.0	5.0	3.2	2.7
		30	7.5	7.5	7.5	4.8	4.1
		40	10.0	10.0	10.0	6.4	5.4
		50	12.5	12.5	12.5	8.0	6.8
		10	NP	4.5	4.5	3.0	2.6
		20	NP	9.0	9.0	6.0	5.1
		30	NP	13.5	13.5	9.0	7.7
		40	NP	18.0	18.0	12.0	10.2
		50	NP	22.5	22.5	15.0	12.8
		10	NP	6.0	6.0	4.5	3.8
		20	NP	12.0	12.0	9.0	7.7
		30	NP	18.0	18.0	13.5	11.5
		40	NP	24.0	24.0	18.0	15.3
		50	NP	30.0	30.0	22.5	19.1
D ₀		10	NP	2.8	2.8	1.8	1.6
		20	NP	5.5	5.5	3.6	3.1
		30	NP	8.3	8.3	5.4	4.6
		40	NP	11.0	11.0	7.2	6.1
		50	NP	13.8	13.8	9.0	7.7
		10	NP	5.3	5.3	3.8	3.2
		20	NP	10.5	10.5	7.5	6.4
		30	NP	15.8	15.8	11.3	9.6
		40	NP	21.0	21.0	15.0	12.8
		50	NP	26.3	26.3	18.8	16.0

		10	NP	7.3	7.3	5.3	4.5
		20	NP	14.5	14.5	10.5	9.0
		30	NP	21.8	21.8	15.8	13.4
		40	NP	29.0	29.0	21.0	17.9
		50	NP	36.3	36.3	26.3	22.3

For SI: 1 inch = 25.4 mm, 1 foot = 304.8 mm, 1 pound per square foot = 0.0479 kPa.

a. Linear interpolation shall be permitted.

b. Wall bracing lengths are based on a soil site class "D." Interpolation of bracing length between the S_{ds} values associated with the seismic design categories shall be permitted when a site-specific S_{ds} value is determined in accordance with Section 1613.3 of the *International Building Code*.

c. Where the braced wall line length is greater than 50 feet, braced wall lines shall be permitted to be divided into shorter segments having lengths of 50 feet or less, and the amount of bracing within each segment shall be in accordance with this table.

d. Method LIB shall have gypsum board fastened to not less than one side with nails or screws in accordance with Table R602.3(1) for exterior sheathing or Table R702.3.5 for interior gypsum board. Spacing of fasteners at panel edges shall not exceed 8 inches.

e. Method CS-SFB does not apply in Seismic Design Categories D_0 , D_1 and D_2 .

f. Methods ABW, PFH, and PFG may be used in conjunction with any bracing method permitted above and shall contribute to the amount of bracing assigned to that bracing method. When used alone in a braced wall line without any other bracing method, they shall be assigned the braced wall line lengths provided for Method WSP.

Reason: As the bracing methods added to the column heading and the proposed footnote are missing in the current Table R602.10.3(3), it could be construed that these methods are not permitted for resisting seismic forces. This is not the case, nor the intent of the existing table.

As Method CS-PF is permitted only in walls that are continuously sheathed, it is added to the right-hand most column where the other continuously sheathed methods are found.

Footnote (f) is proposed to add the remaining missing methods to the table. Methods ABW, PFH, and PFG are narrow wall bracing methods and, as described in the text of the IRC, are permitted to be used with any bracing method. They contribute bracing to the required bracing length for the primary bracing method in the braced wall line where they are used. In addition, all three of the methods addressed in the footnote were originally evaluated using Method WSP as the standard of comparison. Thus, when used by themselves in a braced wall line (For example, a garage section with a PFH on both sides of the garage door and no other bracing in the wall line.), the required bracing length is determined from the Method WSP column in Table R602.10.3(3).

Cost Impact: Will not increase the cost of construction

This code change will not increase the cost of construction. It clarifies the original intent of the code and is likely to save money in the long run as it makes misinterpreting the existing code less likely.

Report of Committee Action Hearings

Committee Action:

Approved as Submitted

Committee Reason: The committee felt this change added important bracing methods into the table and expands the available options.

Assembly Action:

None

Public Comments

Public Comment 2:

Randy Shackelford, representing Simpson Strong-Tie (rshackelford@strongtie.com) requests Approve as Modified by this Public Comment.

Modify as follows:

**TABLE R602.10.3 (3)
BRACING REQUIREMENTS BASED ON SEISMIC DESIGN CATEGORY**

SOIL CLASS D ^b · WALL HEIGHT = 10 FEET · 10 PSF FLOOR DEAD LOAD · 15 PSF ROOF/CEILING DEAD LOAD · BRACED WALL LINE SPACING ≤ 25 FEET			MINIMUM TOTAL LENGTH (FEET) OF BRACED WALL PANELS REQUIRED ALONG EACH BRACED WALL LINE ^{a,f}					
Seismic Design Category	Story Location	Braced Wall Line Length (feet) ^c	Method LIB ^d	Method GB	Methods DWB, SFB, PBS, PCP, HPS, CS-SFB ^e	Methods WSP, ABW, PFH, and PFG ^e	Methods CS-WSP, CS-G, CS-PF	
C (townhouses only)		10	2.5	2.5	2.5	1.6	1.4	
		20	5.0	5.0	5.0	3.2	2.7	
		30	7.5	7.5	7.5	4.8	4.1	
		40	10.0	10.0	10.0	6.4	5.4	
		50	12.5	12.5	12.5	8.0	6.8	
		10	NP	4.5	4.5	3.0	2.6	
		20	NP	9.0	9.0	6.0	5.1	
		30	NP	13.5	13.5	9.0	7.7	
		40	NP	18.0	18.0	12.0	10.2	
		50	NP	22.5	22.5	15.0	12.8	
		10	NP	6.0	6.0	4.5	3.8	
		20	NP	12.0	12.0	9.0	7.7	
		30	NP	18.0	18.0	13.5	11.5	
		40	NP	24.0	24.0	18.0	15.3	
		50	NP	30.0	30.0	22.5	19.1	
	D ₀		10	NP	2.8	2.8	1.8	1.6
			20	NP	5.5	5.5	3.6	3.1
			30	NP	8.3	8.3	5.4	4.6
			40	NP	11.0	11.0	7.2	6.1
			50	NP	13.8	13.8	9.0	7.7
		10	NP	5.3	5.3	3.8	3.2	
		20	NP	10.5	10.5	7.5	6.4	
		30	NP	15.8	15.8	11.3	9.6	
		40	NP	21.0	21.0	15.0	12.8	
		50	NP	26.3	26.3	18.8	16.0	
		10	NP	7.3	7.3	5.3	4.5	
		20	NP	14.5	14.5	10.5	9.0	
		30	NP	21.8	21.8	15.8	13.4	
		40	NP	29.0	29.0	21.0	17.9	
		50	NP	36.3	36.3	26.3	22.3	

For SI: 1 inch = 25.4 mm, 1 foot = 304.8 mm, 1 pound per square foot = 0.0479 kPa.

a. Linear interpolation shall be permitted.

b. Wall bracing lengths are based on a soil site class "D." Interpolation of bracing length between the S_{ds} values associated with the seismic design categories shall be permitted when a site-specific S_{ds} value is determined in accordance with Section 1613.3 of the *International Building Code*.

- c. Where the braced wall line length is greater than 50 feet, braced wall lines shall be permitted to be divided into shorter segments having lengths of 50 feet or less, and the amount of bracing within each segment shall be in accordance with this table.
- d. Method LIB shall have gypsum board fastened to not less than one side with nails or screws in accordance with Table R602.3(1) for exterior sheathing or Table R702.3.5 for interior gypsum board. Spacing of fasteners at panel edges shall not exceed 8 inches.
- e. ~~Method Methods~~ PFG and CS-SFB ~~does do~~ not apply in Seismic Design Categories D₀, D₁ and D₂.
- f. ~~Methods ABW, PFH, and PFG may be used in conjunction with any~~ When more than one bracing method permitted above and shall contribute to the amount of bracing assigned to that bracing method. ~~When is used alone in a braced wall line without any other bracing method, they~~ mixing methods shall be assigned the braced wall line lengths provided for Method WSP in accordance with Section R602.10.4.1.

R602.10.4.1 Mixing methods. Mixing of bracing methods shall be permitted as follows:

1. Mixing intermittent bracing and continuous sheathing methods from story to story shall be permitted.
2. Mixing intermittent bracing methods from *braced wall line* to *braced wall line* within a story shall be permitted. In regions within Seismic Design Categories A, B and C where the ultimate design wind speed is less than or equal to 130 mph (58m/s), mixing of intermittent bracing and continuous sheathing methods from braced wall line to braced wall line within a story shall be permitted.
3. Mixing intermittent bracing methods along a *braced wall line* shall be permitted in Seismic Design Categories A and B, and detached dwellings in Seismic Design Category C, provided the length of required bracing is determined in accordance with Table R602.10.3(1) or R602.10.3(3) is using the highest value of all intermittent bracing methods used.
4. Mixing of continuous sheathing methods CS-WSP, CS-G and CS-PF along a braced wall line shall be permitted. Intermittent methods ABW, PFH and PFG shall be permitted to be used along a *braced wall line* with continuous sheathed methods, provided the length of required bracing for that braced wall line is determined in accordance with Table R602.10.3(1) or R602.10.3(3) using the highest value of the bracing methods used.
5. In Seismic Design Categories A and B, and for detached one- and two-family dwellings in Seismic Design Category C, mixing of intermittent bracing methods along the interior portion of a *braced wall line* with continuous sheathing methods CS-WSP, CS-G and CS-PF along the exterior portion of the same braced wall line shall be permitted. The length of required bracing shall be the highest value of all intermittent bracing methods used in accordance with Table R602.10.3(1) or R602.10.3(3) as adjusted by Tables R602.10.3(2) and R602.10.3(4), respectively. The requirements of Section R602.10.7 shall apply to each end of the continuously sheathed portion of the braced wall line.

Commenter's Reason: We think that it shows favoritism toward certain bracing methods when only one method is added to the bracing length table, and not all applicable bracing methods.

So we are proposing to also add methods ABW, PFH, and PFG to the WSP column heading, since these are considered intermittent bracing methods and their length of bracing would be the same as a WSP panel, since that was the basis for the testing that originally evaluated these methods. Footnote e is revised to include Method PFG because PFG is only permitted in Seismic Design Categories A, B, and C per Section R602.10.6.3. We further revise the proposed Footnote f to point out to the code user that the methods can be combined as long as the requirements of Section R602.10.4.1 are met. Pointing to the general requirements on combining all methods seems better than only showing what is permitted for three methods.

In writing this public comment, we did notice one area of Section R602.10.4.1 which could use improving. That is the case where intermittent ABW, PFH, or PFG methods are mixed with continuous methods (CS-WSP, CS-G, and CS-PF). The issue is that the intermittent ABW, PFH, and PFG methods have their length of bracing based on the intermittent WSP method. The continuous methods require a shorter length of bracing because their basis is assumed to be stronger than the WSP method. If the intermittent narrow methods are combined with the stronger continuous methods and the bracing lengths are based on the continuous method, there will be an insufficient amount of bracing. So a method is proposed that is exactly the same as used in paragraphs #3 above and #5 below this one, where the bracing amount has to be based on the weaker method. This is intended to be exactly the same wording as we propose on our public comment to RB232, but is repeated here in case that proposal is not accepted.

We think this makes an improvement to the code by listing all the applicable bracing methods in the column heading for the seismic bracing length table, giving the user guidance on when all the methods can be combined, and adding the correct method for determining the length of bracing when certain methods are combined.

Final Action Results

RB235-16

AMPC2

Code Change No: RB237-16



Original Proposal


Section: R602.10.3

Proponent: Edward Keith, representing APA- The Engineered Wood Association (ed.keith@apawood.org)

Revise as follows:

TABLE R602.10.3 (4)
SEISMIC ADJUSTMENT FACTORS TO THE REQUIRED LENGTH OF WALL BRACING

ITEM NUMBER	ADJUSTMENT BASED ON:	STORY	CONDITION	ADJUSTMENT FACTOR ^{a, b} [Multiply length from Table R602.10.3(3) by this factor]	APPLICABLE METHODS
1	Story height (Section 301.3)	Any story	≤ 10 feet	1.0	All methods
			> 10 feet and ≤ 12 feet	1.2	
2	Braced wall line spacing, townhouses in SDC C	Any story	≤ 35 feet	1.0	
			> 35 feet and ≤ 50 feet	1.43	
3	Braced wall line spacing, in SDC D ₀ , D ₁ , D ₂ ^c	Any story	> 25 feet and ≤ 30 feet	1.2	
			> 30 feet and ≤ 35 feet	1.4	
4	Wall dead load	Any story	> 8 psf and < 15 psf	1.0	
			< 8 psf	0.85	
5	Roof/ceiling dead load for wall supporting	1-, 2- or 3-story building	≤ 15 psf	1.0	
		2- or 3-story building	> 15 psf and ≤ 25 psf	1.1	
		1-story building or top story	> 15 psf and ≤ 25 psf	1.2	
6	Walls with stone or masonry veneer, townhouses in SDC C ^{d, e}		1.0		
			1.5		

			1.5		
7	Walls with stone or masonry veneer, detached one- and two-family dwellings in SDC D ₀ – D ₂ ^{d,f}	Any story	See Table R602.10.6.5		BV-WSP
8	Interior gypsum board finish (or equivalent)	Any story	Omitted from inside face of braced wall panels	1.5	DWB, WSP, SFB, PBS, PCP, HPS, CS-WSP, CS-G, CS-SFB

For SI: 1 foot = 304.8 mm, 1 pound per square foot = 0.0479 kPa.

- Linear interpolation shall be permitted.
- The total length of bracing required for a given wall line is the product of all applicable adjustment factors.
- The length-to-width ratio for the floor/roof *diaphragm* shall not exceed 3:1. The top plate lap splice nailing shall be in accordance with Table R602.3(1), Item 13.
- Applies to stone or masonry veneer exceeding the first story height.
- The adjustment factor for stone or masonry veneer shall be applied to all exterior *braced wall lines* and all *braced wall lines* on the interior of the building, backing or perpendicular to and laterally supported veneered walls.
- See Section R602.10.6.5 for requirements where stone or masonry veneer does not exceed the first-story height.

Reason: The existing language was added to the IRC in previous cycles to clarify the intent of the code as to the adjustments required for various roof load and story level conditions. The existing language was changed to better correlate with the column heading, "STORY". In doing so, an important condition was inadvertently left out. This combination was the adjustment for the top story of a multiple story building for the condition "> 15 psf and < 25 psf". For this case, as in the 2012 IRC, the appropriate adjustment factor is the same as it is for a single story building. This proposal will correct the error resulting from the wording change at last cycle and bring the provisions back in line with the 2012 and earlier IRCs.

Cost Impact: Will not increase the cost of construction

This change will not increase the cost of construction as the current provisions are in error for the 2015 IRC for those jurisdictions that use the 2012 and earlier IRCs where the adjustment factor was specified correctly.

Report of Committee Action Hearings
--

Committee Action:

Approved as Submitted

Committee Reason: The committee approved this proposal based on the proponents published reason statement. This corrects previous code cycle language that was left out of the 2015 IRC.

Assembly Action:

None

Final Action Results

RB237-16

AS

Code Change No: RB239-16

Original Proposal

Section: R602.10.3, R602.10.6.5

Proponent: Kelly Cobeen, Wiss Janney Elstner Associates, Inc., representing Federal Emergency Management Agency and National Institute of Building Sciences Building Seismic Safety Council Code Resource Support Committee (KCobeen@wje.com)

Revise as follows:

TABLE R602.10.3 (4)
SEISMIC ADJUSTMENT FACTORS TO THE REQUIRED LENGTH OF WALL BRACING

ITEM NUMBER	ADJUSTMENT BASED ON:	STORY	CONDITION	ADJUSTMENT FACTOR ^{a, b} [Multiply length from Table R602.10.3(3) by this factor]	APPLICABLE METHODS
1	Story height (Section 301.3)	Any story	≤ 10 feet	1.0	All methods
			> 10 feet and ≤ 12 feet	1.2	
2	Braced wall line spacing, townhouses in SDC C	Any story	≤ 35 feet	1.0	
			> 35 feet and ≤ 50 feet	1.43	
3	Braced wall line spacing, in SDC D ₀ , D ₁ , D ₂ ^c	Any story	> 25 feet and ≤ 30 feet	1.2	
			> 30 feet and ≤ 35 feet	1.4	
4	Wall dead load	Any story	> 8 psf and < 15 psf	1.0	
			< 8 psf	0.85	
5	Roof/ceiling dead load for wall supporting	1-, 2- or 3-story building	≤ 15 psf	1.0	
		2- or 3-story building	> 15 psf and ≤ 25 psf	1.1	
		1-story building	> 15 psf and ≤ 25 psf	1.2	
6	Walls with stone or masonry veneer, townhouses in SDC C ^{d, e}		1.0	All methods	
			1.5		
			1.5		
7	Walls with stone or masonry veneer, detached one- and two-family dwellings	Any story	See Table R602.10.6.5	BV-WSP	

	in SDC $D_0 - D_2^{a,f}$				
<u>8</u>	Walls with stone or masonry veneer, detached one- and two-family dwellings in SDC $D_0 - D_2^{a,f}$	First and second story of two-story dwelling	See R602.10.6.5	1.2	WSP, CS-WSP
<u>8g</u>	Interior gypsum board finish (or equivalent)	Any story	Omitted from inside face of braced wall panels	1.5	DWB, WSP, SFB, PBS, PCP, HPS, CS-WSP, CS-G, CS-SFB

For SI: 1 foot = 304.8 mm, 1 pound per square foot = 0.0479 kPa.

- Linear interpolation shall be permitted.
- The total length of bracing required for a given wall line is the product of all applicable adjustment factors.
- The length-to-width ratio for the floor/roof *diaphragm* shall not exceed 3:1. The top plate lap splice nailing shall be in accordance with Table R602.3(1), Item 13.
- Applies to stone or masonry veneer exceeding the first story height.
- The adjustment factor for stone or masonry veneer shall be applied to all exterior *braced wall lines* and all *braced wall lines* on the interior of the building, backing or perpendicular to and laterally supported veneered walls.
- See Section R602.10.6.5 for requirements where stone or masonry veneer does not exceed the first-story height.

Revise as follows:

R602.10.6.5 Wall bracing for dwellings with stone and masonry veneer in Seismic Design

Categories D_0 , D_1 and D_2 . Where stone and masonry veneer are installed in accordance with Section R703.8, wall bracing on exterior *braced wall lines* and *braced wall lines* on the interior of the building, backing or perpendicular to and laterally supporting veneered walls shall comply with this section.

Where dwellings in Seismic Design Categories D_0 , D_1 and D_2 have stone or masonry veneer installed in accordance with Section R703.8, and the veneer does not exceed the first-story height, wall bracing shall be in accordance with Section R602.10.3.

Where detached one- or two-family dwellings in Seismic Design Categories D_0 , D_1 and D_2 have stone or masonry veneer installed in accordance with Section R703.7, and the veneer exceeds the first-story height, wall bracing at exterior *braced wall lines* and *braced wall lines* on the interior of the building shall be constructed using Method BV-WSP in accordance with this section and Figure R602.10.6.5. Cripple walls shall not be permitted, and required interior *braced wall lines* shall be supported on continuous foundations.

Where detached one- or two-family dwellings in Seismic Design Categories D_0 , D_1 and D_2 have exterior veneer installed in accordance with Section R703.8 and are braced in accordance with methods WSP or CS-WSP, veneer shall be permitted in the second story in accordance with Items 1 or 2 below, provided the dwelling does not extend more than two stories above grade plane, the veneer does not exceed 5 inches in thickness, the height of veneer on gable-end walls does not extend more than eight feet above the bearing wall top plate elevation, and the total length of braced wall panel specified by Table R602.10.3 is multiplied by 1.2 for each first and second story braced wall line.

- The total area of the veneer on the second-story exterior walls shall be permitted to extend up to 25 percent of the occupied second floor area, or
- The veneer on the second-story exterior walls shall be permitted to cover one side of the dwelling, including walls on bay windows and similar appurtenances within the one dwelling side.

Townhouses in Seismic Design Categories D_0 , D_1 and D_2 with stone or masonry veneer exceeding the first-story height shall be designed in accordance with accepted engineering practice.

Reason: In some regions with high seismicity, home builders are commonly installing a limited area of veneer on the second story of two-story dwellings, particularly on the street side of the dwelling. In Seismic Design Categories D_0 , D_1 and D_2 when any veneer

extends above the first story, the 2015 IRC requires the use of BV-WSP bracing, with a complete set of tie-downs in exterior walls over all stories. This current IRC requirement can be cost-prohibitive. The intent of this code change is to provide another alternative in which a moderate amount of second story veneer is permitted with a moderate increase in the bracing wall length, while maintaining a similar level of seismic safety.

Cost Impact: Will not increase the cost of construction

This proposal will notably reduce the cost of construction by removing the cost of most or all tie-down hardware. For one example dwelling the cost savings is estimated to be approximately \$3,500.00, including \$3,000 for materials and labor to install tie-downs, and \$500.00 in design costs.

Report of Committee Action Hearings
--

Committee Action:

Approved as Submitted

Committee Reason: The committee felt this is a good change as it adds alternatives that allows a minimal amount of masonry veneer to the second story in SDC D₀, D₁ and D₂.

Assembly Action:

None

Final Action Results

RB239-16

AS

Code Change No: **RB240-16**

Original Proposal

Section: R602.10.4

Proponent: Matthew Hunter, representing American Wood Council (mhunter@awc.org)

Revise as follows:

**TABLE R602.10.4
BRACING METHODS**

METHODS, MATERIAL		MINIMUM THICKNESS	FIGURE	CONNECTION CRITERIA ^a	
				Fasteners	Spacing
Intermittent Bracing Method	LIB Let-in-bracing	1 × 4 wood or approved metal straps at 45° to 60° angles for maximum 16" stud spacing		Wood: 2-8d common nails or 3-8d (2 ¹ / ₂ " long × 0.113" dia.) nails	Wood: per stud and top and bottom plates
				Metal strap: per manufacturer	Metal: per manufacturer
	DWB Diagonal wood boards	³ / ₄ " (1" nominal) for maximum 24" stud spacing		2-8d (2 ¹ / ₂ " long × 0.113" dia.) nails or 2 - 1 ³ / ₄ " long staples	Per stud
	WSP Wood structural panel (See Section R604)	³ / ₈ "		Exterior sheathing per Table R602.3(3)	6" edges 12" field
				Interior sheathing per Table R602.3(1) or R602.3(2)	Varies by fastener
	BV-WSP⁶ Wood structural panels with stone or masonry veneer (See Section R602.10.6.5)	⁷ / ₁₆ "	See Figure R602.10.6.5	8d common (2 ¹ / ₂ " × 0.131) nails	4" at panel edges 12" at intermediate supports 4" at braced wall panel end posts
	SFB Structural fiberboard sheathing	¹ / ₂ " or ²⁵ / ₃₂ " for maximum 16" stud spacing		1 ¹ / ₂ " long × 0.12" dia. (for ¹ / ₂ " thick sheathing) or 1 ³ / ₄ " long × 0.12" dia. (for ²⁵ / ₃₂ " thick sheathing) galvanized roofing nails or 8d common (2 1/2" long × 0.131" dia.) nails	3" edges 6" field
	GB Gypsum board	¹ / ₂ "		Nails or screws per Table R602.3(1) for exterior locations	For all braced wall panel locations:
			Nails or screws per Table R702.3.5 for interior locations	7" edges (including top and bottom plates) 7" field	
PBS Particleboard sheathing (See Section R605)	³ / ₈ " or ¹ / ₂ " for maximum 16" stud spacing		For ³ / ₈ ", 6d common (2" long × 0.113" dia.) nails For ¹ / ₂ ", 8d common (2 ¹ / ₂ " long × 0.131" dia.) nails	3" edges 6" field	

	PCP Portland cement plaster	See Section R703.6 for maximum 16" stud spacing		1 1/2" long, 11 gage, 7/16" dia. head nails or 7/8" long, 16 gage staples	6" o.c. on all framing members
	HPS Hardboard panel siding	7/16" for maximum 16"stud spacing		0.092" dia., 0.225" dia. head nails with length to accommodate 1 1/2" penetration into studs	4" edges 8" field
	ABW Alternate braced wall	3/8"		See Section R602.10.6.1	See Section R602.10.6.1

METHODS, MATERIAL		MINIMUM THICKNESS	FIGURE	CONNECTION CRITERIA ^a	
				Fasteners	Spacing
Intermittent Bracing Methods	PFH Portal frame with hold-downs	3/8"		See Section R602.10.6.2	See Section R602.10.6.2
	PFG Portal frame at garage	7/16"		See Section R602.10.6.3	See Section R602.10.6.3
Continuous Sheathing Methods	CS-WSP Continuously sheathed wood structural panel	3/8"		Exterior sheathing per Table R602.3(3) Interior sheathing per Table R602.3(1) or R602.3(2)	6" edges 12" field Varies by fastener
	CS-G^b ^c Continuously sheathed wood structural panel adjacent to garage openings	3/8"		See Method CS-WSP	See Method CS-WSP
	CS- PF Continuously sheathed portal frame	7/16"		See Section R602.10.6.4	See Section R602.10.6.4
	CS-SFB^d Continuously sheathed structural fiberboard	1 1/2" or 25/32" for maximum 16" stud spacing		1 1/2" long × 0.12" dia. (for 1/2" thick sheathing) or 1 3/4" long × 0.12" dia. (for 25/32" thick sheathing) galvanized roofing nails or 8d common (2 1/2" long × 0.131" dia.) nails	3" edges 6" field

For SI: 1 inch = 25.4 mm, 1 foot = 304.8 mm, 1 degree = 0.0175 rad, 1 pound per square foot = 47.8 N/m², 1 mile per hour = 0.447 m/s.

- Adhesive attachment of wall sheathing, including Method GB, shall not be permitted in Seismic Design Categories C, D₀, D₁ and D₂.
- Applies to panels next to garage door opening where supporting gable end wall or roof load only. Shall only be used on one wall of the garage. In Seismic Design Categories D₀, D₁ and D₂ roof covering dead load shall not exceed 3 psf.
- Garage openings adjacent to a Method CS-G panel shall be provided with a header in accordance with Table R602.7(1). A full-height clear opening shall not be permitted adjacent to a Method CS-G panel.
- Method CS-SFB does not apply in Seismic Design Categories D₀, D₁ and D₂.
- Method applies to detached one- and two-family dwellings in Seismic Design Categories D₀ through D₂ only.

Reason: 8d common nails are no longer recommended for use with structural fiberboard sheathing. Removal of 8d common nails from Table R602.3.(1) for attachment of structural fiberboard sheathing was the result of proposal S75-06/07 Part II. Removal of the 8d common nail aligns with the prescribed attachment for fiberboard sheathing per fastener schedule Table R602.3(1).

Cost Impact: Will not increase the cost of construction

Other code approved, prescriptive methods are permitted in lieu of the 8d nail size. Therefore there is no cost increase associated with this revision.

**Report of Committee Action
Hearings**

Committee Action:

Approved as Submitted

Errata: In Table R602,10.4, under column heading FIGURE, the figures are not to be deleted.

Committee Reason: The committee approved this proposal based on the proponents published reason statement.

Assembly Action:

None

Final Action Results

RB240-16

AS

Code Change No: RB241-16

Original Proposal

Section: R602.10.5

Proponent: Edward Keith, representing APA- The Engineered Wood Association (ed.keith@apawood.org)

Revise as follow:

TABLE R602.10.5
MINIMUM LENGTH OF BRACED WALL PANELS

METHOD (See Table R602.10.4)		MINIMUM LENGTH ^a (inches)					CONTRIBUTING LENGTH (inches)
		Wall Height					
		8 feet	9 feet	10 feet	11 feet	12 feet	
DWB, WSP, SFB, PBS, PCP, HPS, BV-WSP		48	48	48	53	58	Actual ^b
GB		48	48	48	53	58	Double sided = Actual Single sided = 0.5 x Actual
LIB		55	62	69	NP	NP	Actual ^b
ABW	SDC A, B and C, ultimate design wind speed	28	32	34	38	42	48
	SDC D ₀ , D ₁ and D ₂ , ultimate design wind speed	32	32	34	NP	NP	
PFH	Supporting roof only	16	16	16	18 ^e	20 ^e	48
	Supporting one story and roof	24	24	24	27 ^e	29 ^e	48
PFG		24	27	30	33 ^d	36 ^d	1.5 x Actual ^b
CS-G		24	27	30	33	36	Actual ^b
CS-PF	SDC A, B and C	16	18	20	22 ^e	24 ^e	1.5 x Actual ^b
	SDC D ₀ , D ₁ and D ₂	16	18	20	22 ^e	24 ^e	Actual ^b
CS-WSP, CS-SFB	Adjacent clear opening height (inches)	-	-	-	-	-	-
	≤ 64	24	27	30	33	36	Actual ^b
	68	26	27	30	33	36	
	72	27	27	30	33	36	
	76	30	29	30	33	36	
	80	32	30	30	33	36	
	84	35	32	32	33	36	
88	38	35	33	33	36		

	92	43	37	35	35	36	
	96	48	44	38	36	36	
	100	—	44	40	38	38	
	104	—	49	43	40	39	
	108	—	54	46	43	44	
	112	—	—	50	45	43	
	116	—	—	55	48	45	
	120	—	—	60	52	48	
	124	—	—	—	56	51	
	128	—	—	—	61	54	
	132	—	—	—	66	58	
	136	—	—	—	—	62	
	140	—	—	—	—	66	
	144	—	—	—	—	72	
METHOD (See Table R602.10.4)		MINIMUM LENGTH^a (inches)					CONTRIBUTING LENGTH (inches)
		Wall Height					
		8 feet	9 feet	10 feet	11 feet	12 feet	
DWB, WSP, SFB, PBC, PCP, HPS, BV-WSP		48	48	48	53	58	Actual ^b
GB		48	48	48	53	58	Double sided = Actual ^b Single sided = 0.5 x Actual ^b
LIB		55	62	69	NP	NP	Actual ^b
ABW	SDC A, B and C Wind speed < 110 mph	28	32	34	38	42	48
	SDC D₀, D₁ and D₂ Wind speed < 110 mph	32	32	34	NP	NP	
CS-G		24	27	30	33	36	Actual ^b
CS-WSP, CS-SFB	Adjacent clear opening height (inches)	-	-	-	-	-	Actual ^b
	<64	24	27	30	33	36	
	68	26	27	30	33	36	
	72	27	27	30	33	36	
	76	30	29	30	33	36	
	80	32	30	30	33	36	
	84	35	32	32	33	36	
	88	38	35	33	33	36	
	92	43	37	35	35	36	
	96	48	41	38	36	36	
	100	---	44	40	38	38	
	104	---	49	43	40	39	
	108	---	54	46	43	41	
	112	---	---	50	45	43	
116	---	---	55	48	45		
120	---	---	60	52	48		

	124	---	---	---	56	51		
	128	---	---	---	61	54		
	132	---	---	---	66	58		
	136	---	---	---	---	62		
	140	---	---	---	---	66		
	144	---	---	---	---	72		
METHOD		Wall Portal Header Height						
(See Table R602.10.4)		8 feet	9 feet	10 feet	11 feet	12 feet		
PFH	Supporting roof only	16	16	16	Footnote c	Footnote c	48	
	Supporting one story and roof	24	24	24	Footnote c	Footnote c	48	
PFG		24	27	30	Footnote d	Footnote d	1.5 x Actual ^b	
CS-PF	SDC A, B and C	16	18	20	Footnote e	Footnote e	1.5 x Actual ^b	
	SDC D ₀ , D ₁ and D ₂	16	18	20	Footnote e	Footnote e	Actual ^b	

For SI: 1 inch = 25.4 mm, 1 foot = 304.8 mm, 1 mile per hour = 0.447 m/s.

NP = Not Permitted.

a. Linear interpolation shall be permitted.

b. Use the actual length where it is greater than or equal to the minimum length.

c. Maximum header height for PFH is 10 feet in accordance with Figure R602.10.6.2, but wall height shall be permitted to be increased to 12 feet with pony wall.

d. Maximum opening header height for PFG is 10 feet in accordance with Figure R602.10.6.3, but wall height shall be permitted to be increased to 12 feet with pony wall.

e. Maximum opening header height for CS-PF is 10 feet in accordance with Figure R602.10.6.4, but wall height shall be permitted to be increased to 12 feet with pony wall

Reason: The proposed table was reorganized to place the portal frame bracing methods at the bottom of the table for clarity. This change proposal is the results of full-scale tests conducted to determine the correct way to measure portal frame height-to-leg-length aspect ratios. It is unclear from the evolution of the IRC from 2006 through the current 2015 whether the portal frame aspect ratio is dependent on the height of the portal frame or the height of the wall. With the advent of provisions that permit pony walls up to 4-feet-tall over portal frames, the distinction becomes increasingly relevant. APA conducted full-scale tests comparing the performance of conventional 8-foot-tall portals fabricated with portal leg lengths of 16 inches for an aspect ratio (portal height/portal length) of 6:1. From this testing, baseline performance values were arrived at by using cyclic testing in accordance with ASTM E2126 and evaluated using ICC-ES Acceptance Criteria AC130. This research is contained in APA Report T2014L-39 (Copies available for free download at www.apawood.org).

APA then tested 8-foot-tall portal frames with 4-foot-tall pony walls on top of them. Two sets of specimens were tested; one set with a 6:1 aspect ratio measured using the 8 foot portal height (16" portal-leg length) like the controls. The other set of specimens was constructed with a 24-inch-long portal-leg-length providing a 6:1 aspect ratio based on the 12 foot wall height.

The results of this testing indicate that measuring the aspect ratio as the portal height over the portal leg length is the appropriate way to measure the aspect ratio when pony walls are used over the portal frames. Testing further indicated that the use of a pony wall over the portal frame actually increases slightly the overall capacity of the portal frame. As such, using the "portal height" in the portal frame height-to-leg-length aspect ratio is not only a best match for walls with pony walls when compared with normal 6:1 aspect ratio walls without pony walls, it also provides increasingly conservative performance as the pony wall increases in height.

Given the results of the testing, the portal frames were placed at the bottom of the table where the "Portal Height" is appropriate for determining minimum portal leg length, leaving the upper portions of the table dependent on the "Wall Height" as is appropriate for the traditional panel-type bracing methods.

Another change is proposed for Footnotes (d) and (e). Currently, both footnotes specify a maximum opening height of 10 feet, when the figures referenced in the footnotes clearly provide for a maximum 10-foot-header height. This change corrects contradictions existent in the present edition of the code.

Cost Impact: Will not increase the cost of construction

These provisions will not increase the cost of construction. It provides information based on full scale testing that will permit slightly narrower portal frame leg lengths where appropriate based on the aspect ratio of the portal height as opposed to the wall height. The elimination of the conflict with the footnotes and the table discussed above should clarify, make the code easier to use and permit narrower panels to count toward bracing.

**Report of Committee Action
Hearings**

Committee Action:

Approved as Modified

Modify as follows:

**TABLE R602.10.5
MINIMUM LENGTH OF BRACED WALL PANELS**

METHOD (See Table R602.10.4)	MINIMUM LENGTH ^a (inches)					CONTRIBUTING LENGTH (inches)	
	Wall Height						
	8 feet	9 feet	10 feet	11 feet	12 feet		
DWB, WSP, SFB, PBC, PCP, HPS, BV-WSP	48	48	48	53	58	Actual ^b	
GB	48	48	48	53	58	Double sided = Actual ^b Single sided = 0.5 x Actual ^b	
LIB	55	62	69	NP	NP	Actual ^b	
ABW	SDC A, B and C <u>ultimate design</u> wind speed < <u>140 mph</u>	28	32	34	38	42	48
	SDC D ₀ , D ₁ and D ₂ <u>ultimate design</u> wind speed < <u>140 mph</u>	32	32	34	NP	NP	
CS-G		24	27	30	33	36	Actual ^b
CS-WSP, CS-SFB	Adjacent clear opening height (inches)						
	<64	24	27	30	33	36	Actual ^b
	68	26	27	30	33	36	
	72	27	27	30	33	36	
	76	30	29	30	33	36	
	80	32	30	30	33	36	

84	35	32	32	33	36
88	38	35	33	33	36
92	43	37	35	35	36
96	48	41	38	36	36
100	---	44	40	38	38
104	---	49	43	40	39
108	---	54	46	43	41
112	---	---	50	45	43
116	---	---	55	48	45
120	---	---	60	52	48
124	---	---	---	56	51
128	---	---	---	61	54
132	---	---	---	66	58
136	---	---	---	---	62
140	---	---	---	---	66
144	---	---	---	---	72

METHOD (See Table R602.10.4)		Portal Header Height to Top of Portal Header					
		8 feet	9 feet	10 feet	11 feet	12 feet	
PFH	Supporting roof only	16	16	16	Footnote c	Footnote c	48
	Supporting one story and roof	24	24	24	Footnote c	Footnote c	48
PFG		24	27	30	Footnote d	Footnote d	1.5 x Actual ^b
CS-PF	SDC A, B and C	16	18	20	Footnote e	Footnote e	1.5 x Actual ^b
	SDC D ₀ , D ₁ and D ₂	16	18	20	Footnote e	Footnote e	Actual ^b

For SI: 1 inch = 25.4 mm, 1 foot = 304.8 mm, 1 mile per hour = 0.447 m/s.

NP = Not Permitted.

-
- a. Linear interpolation shall be permitted.
-
- b. Use the actual length where it is greater than or equal to the minimum length.
-
- c. Maximum header height for PFH is 10 feet in accordance with Figure R602.10.6.2, but wall height shall be permitted to be increased to 12 feet with pony wall.
-
- d. Maximum header height for PFG is 10 feet in accordance with Figure R602.10.6.3, but wall height shall be permitted to be increased to 12 feet with pony wall.
-
- e. Maximum header height for CS-PF is 10 feet in accordance with Figure R602.10.6.4, but wall height shall be permitted to be increased to 12 feet with pony wall.

Committee Reason: The committee approved this proposal based on the proponents published reason statement. Also, it reorganizes the table in order to place portal frames at the bottom since portal height not wall height is used. The modification corrected the wind speed at ABW to ultimate design wind speed.

Assembly Action

None

Final Action Results

RB241-16

AM

Code Change No: RB243-16

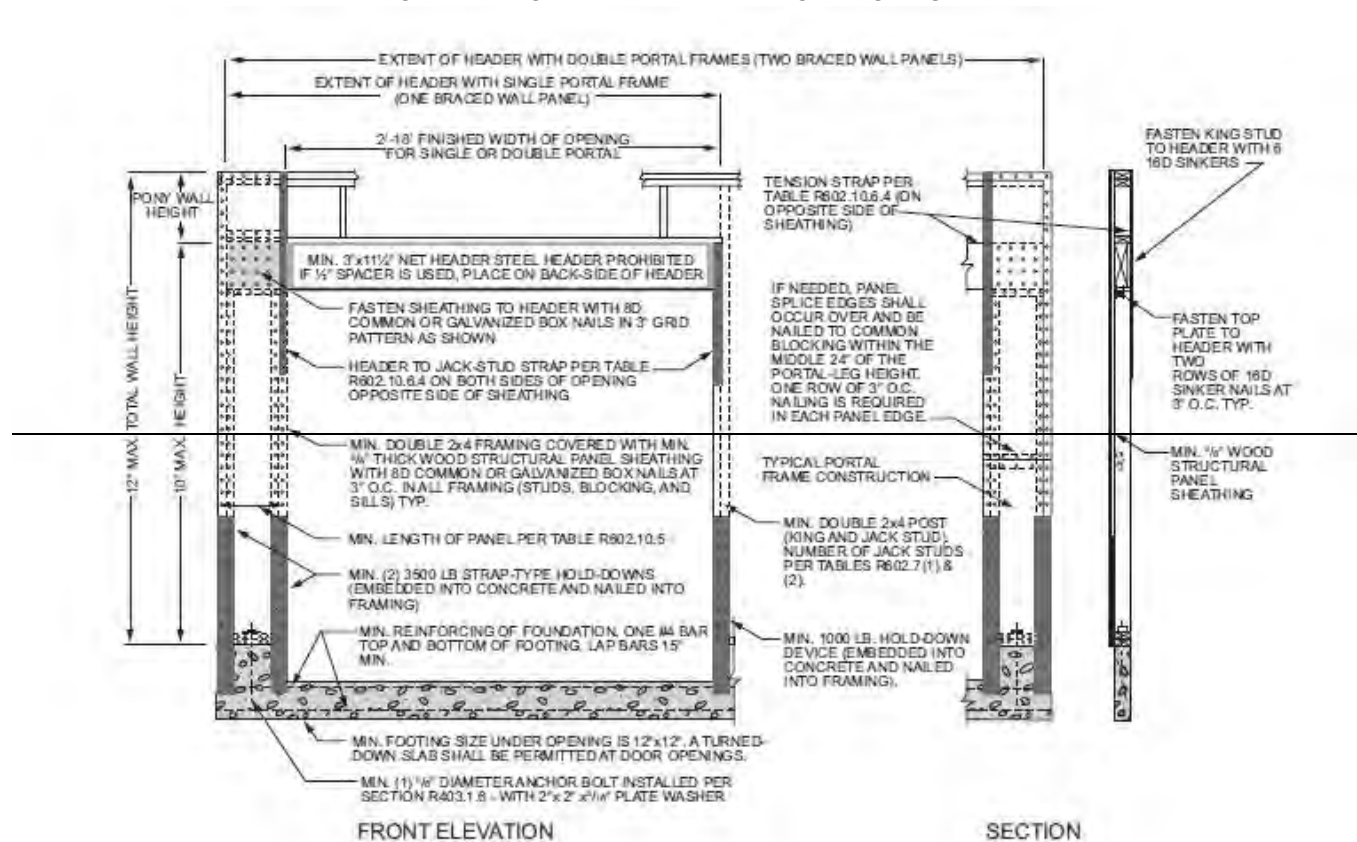
Original Proposal

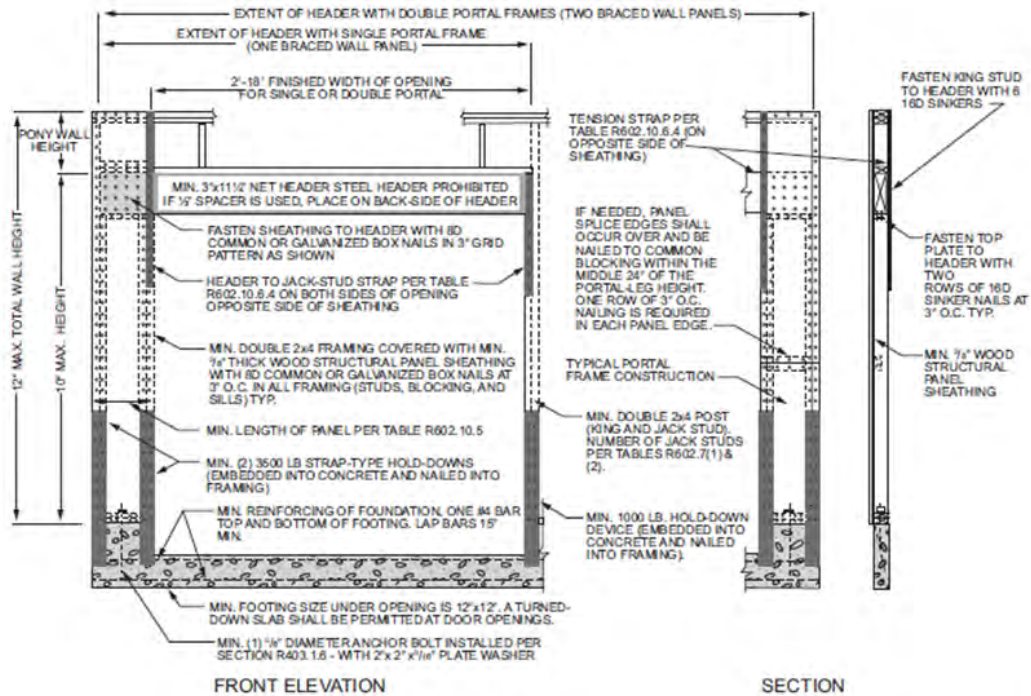
Section: R602.10.6.2

Proponent: Edward Keith, representing APA- The Engineered Wood Association (ed.keith@apawood.org)

Revise as follows:

**FIGURE R602.10.6.2
METHOD PFH—PORTAL FRAME WITH HOLD-DOWNS**





Note: Nailing of sheathing behind the 3500-lb strap shall not be required.

For SI: 1 inch = 25.4 mm, 1 foot = 304.8 mm.

FIGURE R602.10.6.2
METHOD PFH PORTAL FRAME WITH HOLD-DOWNS

For SI: 1 inch = 25.4 mm, 1 foot = 304.8 mm.

Reason: The required nailing on the 3500 lb strap provides sufficient anchorage for the wood structural panel to framing connection while prevent the potential for splitting of the framing while anchoring the strap. It also prevents the sheathing-to-framing nailing from interfering with the required strap nailing. In addition it saves time and money for the builder without compromising the effectiveness of the portal.

Cost Impact: Will not increase the cost of construction
 This change proposal will not increase the cost of construction and may save the builder a little time and money during construction without impacting the performance of the structure.

Report of Committee Action Hearings

Committee Action:

Approved as Submitted

Committee Reason: This proposal clarifies that nailing behind the strap is not required and based on the proponents published reason statement.

Assembly Action:

None

Final Action Results

RB243-16

AS

Code Change No: **RB244-16**

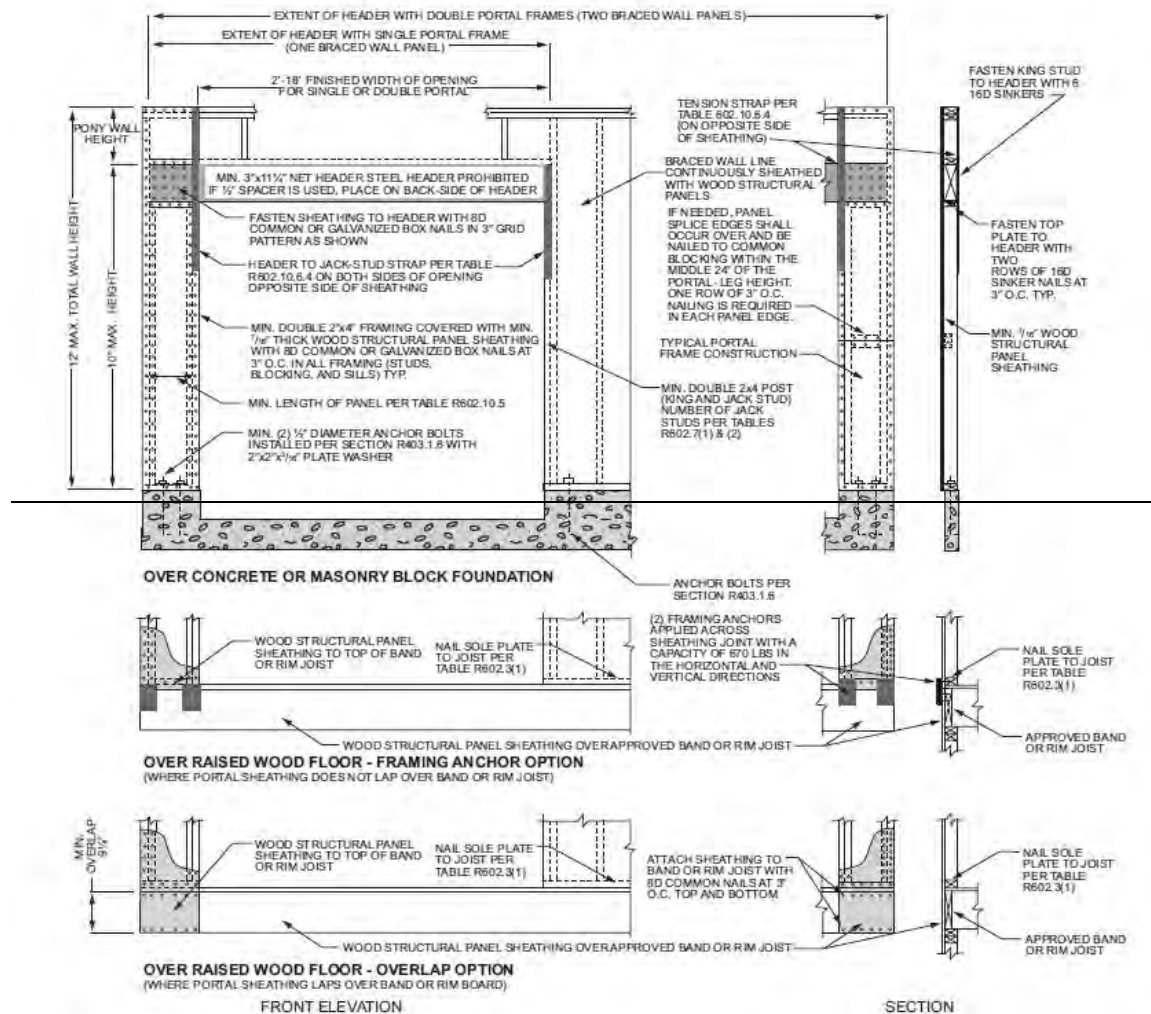
Original Proposal

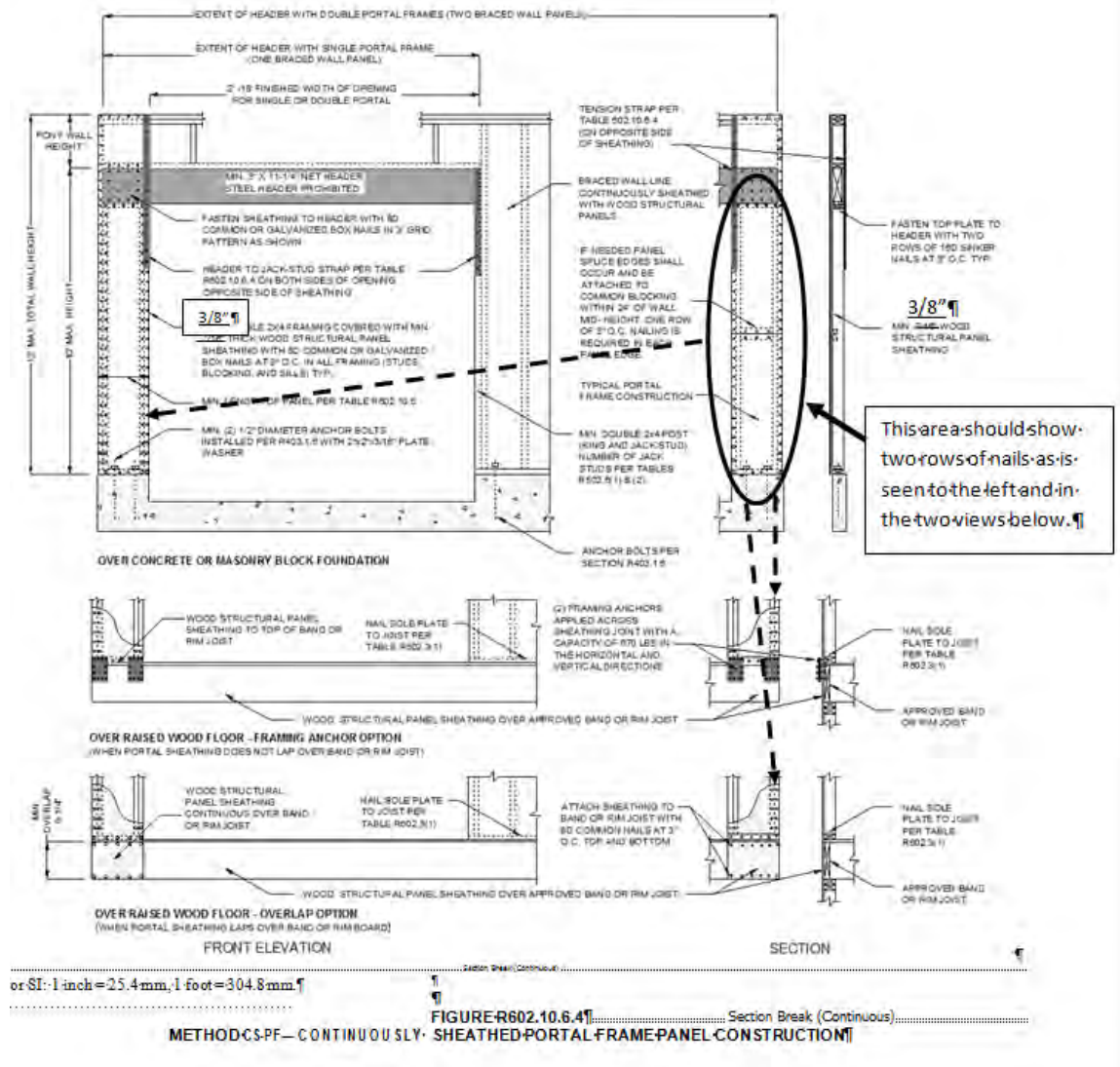
Section: R602.10.6.4

Proponent: Edward Keith, representing APA- The Engineered Wood Association (ed.keith@apawood.org)

Revise as follows:

FIGURE R602.10.6.4
METHOD CS-PF—CONTINUOUSLY SHEATHED PORTAL FRAME PANEL CONSTRUCTION





Report of Committee Action Hearings

Committee Action:

Approved as Submitted

Committee Reason: The committee approved this proposal based on the proponents published reason statement.

Assembly Action:

None

Final Action Results

RB244-16

AS

Code Change No: **RB245-16**

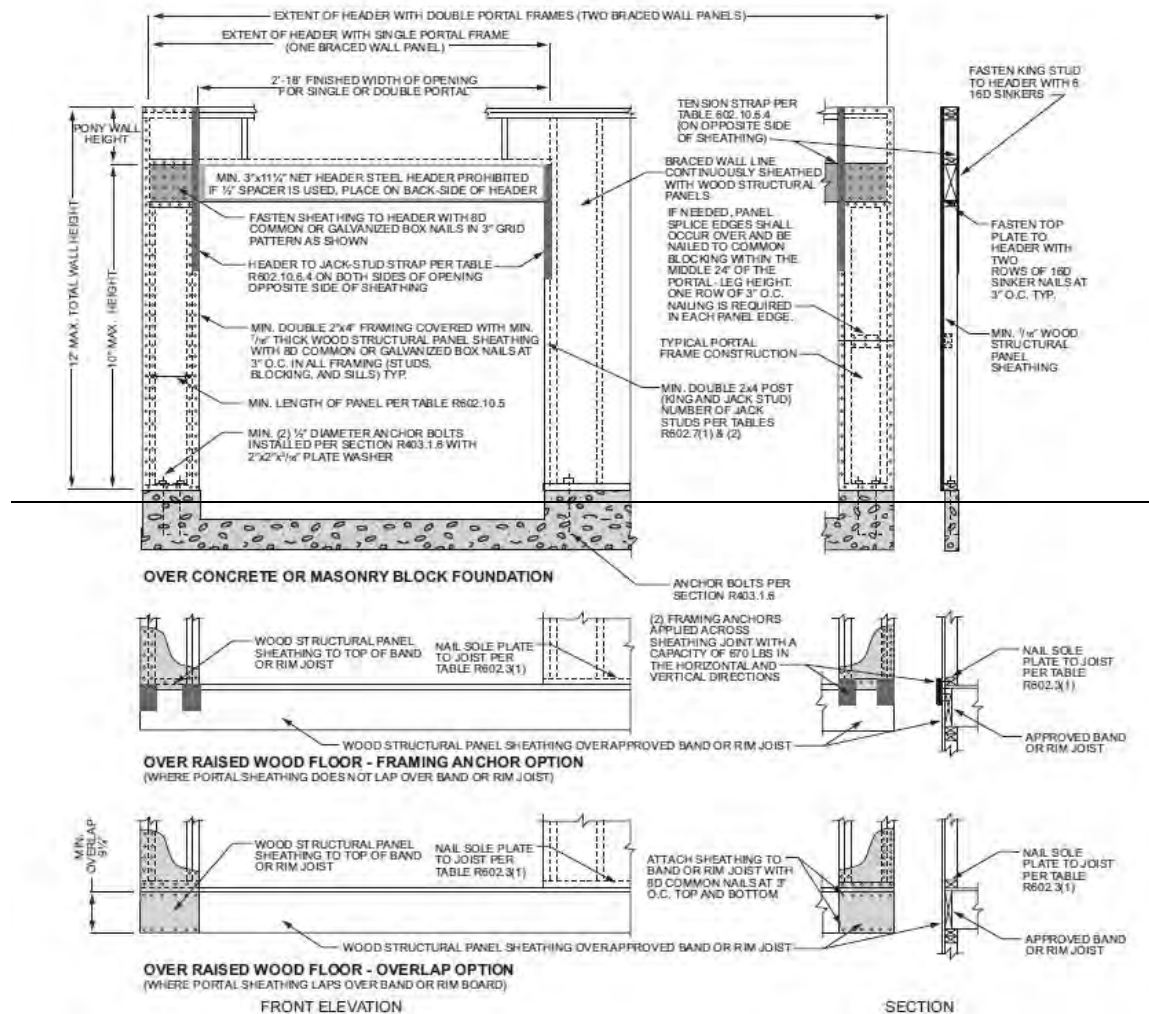
Original Proposal

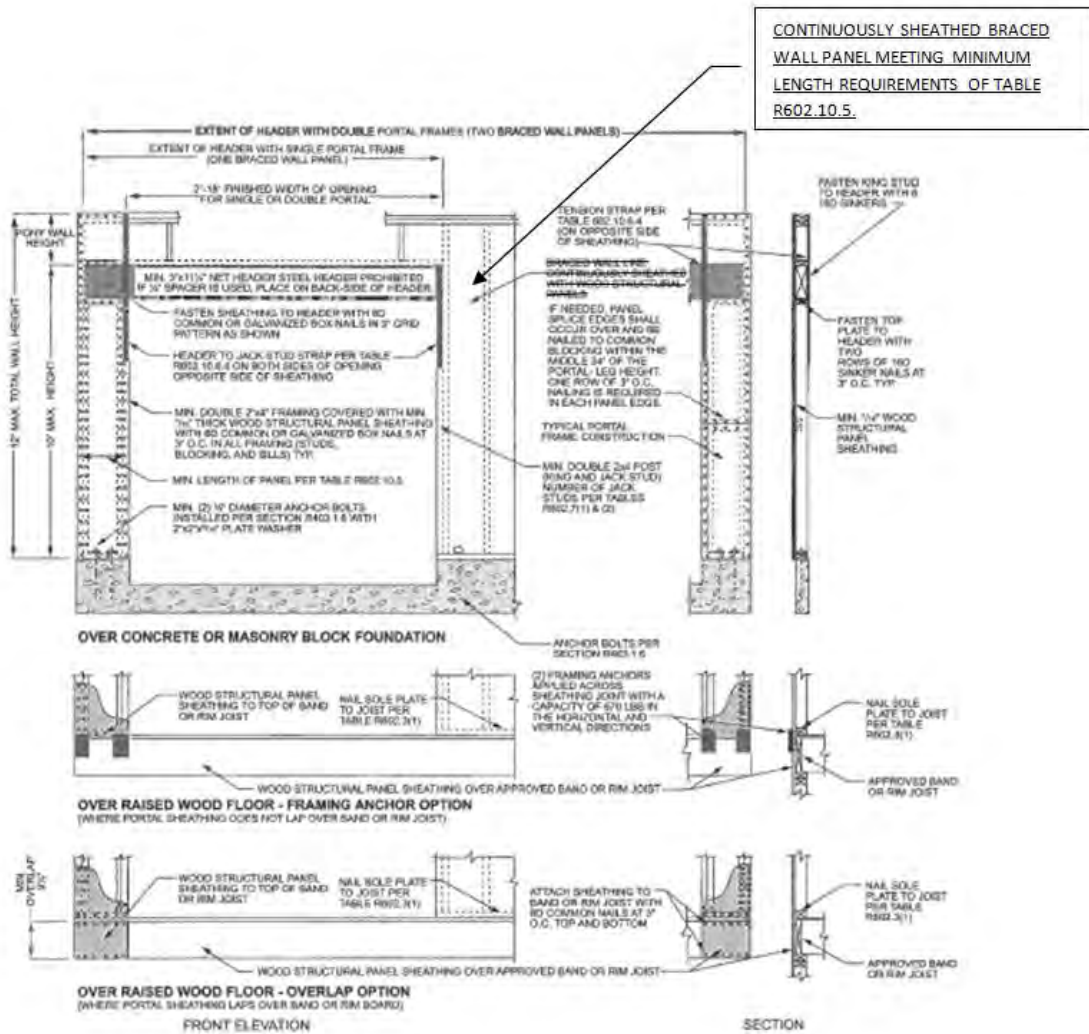
Section: R602.10.6.4

Proponent: Edward Keith, representing APA- The Engineered Wood Association (ed.keith@apawood.org)

Revise as follows:

FIGURE R602.10.6.4
METHOD CS-PF—CONTINUOUSLY SHEATHED PORTAL FRAME PANEL CONSTRUCTION





For SI: 1 inch = 25.4 mm, 1 foot = 304.8 mm.

Reason: The proposed code change more clearly states the intent of the original language. It is important that the wall element away from the single portal be well anchored to obviate the need for the anchor strap at the base of the post-end of the single-portal. This anchorage is provided by the presence of a continuously sheathed braced wall panel meeting the minimum length requirements of Table R602.10.5. The way the current figure treats the post-end sheathing requirement, any element of a continuously sheathed braced wall line, regardless of length, could be used. Even an element less than the minimum length requirements listed in Table R602.10.5 would be permitted even though such an element would not provide the necessary anchorage. This proposal modifies the language to more clearly represent the intent of the provision.

Cost Impact: Will not increase the cost of construction
 This change will not increase the cost of construction as it clarifies the original intent of the code provision.

Report of Committee Action Hearings

Committee Action:

Approved as Submitted

Committee Reason: This change clarifies the need that a minimum length panel as proscribed in Table R602.10.5 is required on the side opposite the single portal.

Assembly Action:

None

Final Action Results

RB245-16

AS

Code Change No: RB248-16

Original Proposal

Section: R603.1.1, R603.3.1, R603.3.1.1, R603.3.2, R603.3.2.1, R603.3.5, R603.6, R603.7, R603.8, R603.9.2, R603.9.4.1

Proponent: Jon-Paul Cardin, American Iron and Steel Institute, representing American Iron and Steel Institute (JCardin@steel.org)

Revise as follows:

R603.1.1 Applicability limits. The provisions of this section shall control the construction of exterior cold-formed steel wall framing and interior load-bearing cold-formed steel wall framing for buildings not more than 60 feet (18 288 mm) long perpendicular to the joist or truss span, not more than 40 feet (12 192 mm) wide parallel to the joist or truss span, and less than or equal to three stories above grade plane. Exterior walls installed in accordance with the provisions of this section shall be considered as load-bearing walls. Cold-formed steel walls constructed in accordance with the provisions of this section shall be limited to sites where the ultimate design wind speed is less than ~~139~~140 miles per hour (~~62.63~~63 m/s), Exposure Category B or C, and the ground snow load is less than or equal to 70 pounds per square foot (3.35 kPa).

**TABLE R603.3.1
WALL TO FOUNDATION OR FLOOR CONNECTION REQUIREMENTS^{a, b}**

FRAMING CONDITION	ULTIMATE WIND SPEED AND EXPOSURE CATEGORY (mph)					
	115 B	126 B or 140 C <u>120 B</u>	130 B <139 B or 115 C	126 C <140 B or 120 C	<139 C <u>130 C</u>	<u><140 C</u>
Wall bottom track to floor per Figure R603.3.1(1)	1-No. 8 screw at 12" o.c.	1-No. 8 screw at 12"8" o.c.	4 2-No. 8 screw at 12"8" o.c.	2-No. 8 screws at 12"6" o.c.	2 3-No. 8 screws at 12"8" o.c.	<u>3</u> -No. 8 screws at <u>6"</u> o.c.
Wall bottom track to foundation per Figure R603.3.1(2) ^d	$\frac{1}{2}$ " minimum diameter anchor bolt at 6' o.c.	$\frac{1}{2}$ " minimum diameter anchor bolt at 4 <u>6</u> ' o.c.	$\frac{1}{2}$ " minimum diameter anchor bolt at 4' o.c.	$\frac{1}{2}$ " minimum diameter anchor bolt at 4' o.c.	$\frac{1}{2}$ " minimum diameter anchor bolt at 4 <u>3</u> '- <u>4</u> " o.c.	<u>$\frac{1}{2}$"</u> minimum diameter anchor bolt at <u>2</u> '- <u>8</u> " o.c.
Wall bottom track to wood sill per Figure R603.3.1(3)	Steel plate spaced at 4' o.c., with 4-No. 8 screws and 4-10d or 6-8d common nails	Steel plate spaced at 3 <u>4</u> ' o.c., with 4-No. 8 screws and 4-10d or 6-8d common nails	Steel plate spaced at 3' o.c., with 4-No. 8 screws and 4-10d or 6-8d common nails	Steel plate spaced at 2 <u>3</u> ' o.c., with 4-No. 8 screws and 4-10d or 6-8d common nails	Steel plate spaced at 2' o.c., with 4-No. 8 screws and 4-10d or 6-8d common nails	<u>Steel plate spaced at 1</u> '- <u>4</u> " o.c., with <u>4</u> - <u>No. 8</u> screws and <u>4</u> - <u>10d</u> or <u>6</u> - <u>8d</u> common nails
Wind uplift connector strength (lbs) ^{c, e}	Stud Spacing (inches)	Roof Span (feet)				

	16	24	NR	NR	NR	<u>NR 424</u>	<u>NR209</u>	<u>NR</u>
		28	NR	NR	<u>NR62</u>	<u>NR151</u>	<u>NR249</u>	<u>339</u>
		32	NR	NR	<u>NR 79</u>	<u>NR 179</u>	<u>NR 289</u>	<u>382</u>
		36	NR	NR	<u>NR 94</u>	<u>NR 206</u>	<u>333 329</u>	<u>426</u>
		40	NR	<u>NR 64</u>	<u>NR 117</u>	<u>NR 239</u>	<u>368 374</u>	<u>470</u>
	24	24	NR	NR	<u>NR 69</u>	<u>NR 186</u>	<u>343 314</u>	<u>443</u>
		28	NR	NR	<u>NR 93</u>	<u>NR 227</u>	<u>395 374</u>	<u>508</u>
		32	NR	NR	<u>NR 117</u>	<u>330 268</u>	<u>447 434</u>	<u>573</u>
		36	NR	<u>NR 64</u>	<u>NR 144</u>	<u>371 309</u>	<u>500 494</u>	<u>639</u>
		40	NR	<u>NR 92</u>	<u>345 176</u>	<u>411 359</u>	<u>552 562</u>	<u>704</u>

For SI: 1 inch = 25.4 mm, 1 mile per hour = 0.447 m/s, 1 foot = 304.8 mm, 1 pound = 4.45 N.

- Anchor bolts are to be located not more than 12 inches from corners or the termination of bottom tracks such as, at door openings or corners. Bolts are to extend not less than 15 inches into masonry or 7 inches into concrete.
- All screw sizes shown are minimum.
- NR = Uplift connector not required.
- Foundation anchor straps are permitted in place of anchor bolts, if spaced as required to provide equivalent anchorage to the required anchor bolts and installed in accordance with manufacturer's requirements.
- See Figure R603.3.1(4) for details.

TABLE R603.3.1.1 (1)
GABLE ENDWALL TO FLOOR CONNECTION REQUIREMENTS^{a, b, c}

ULTIMATE BASIC WIND SPEED (mph)		WALL BOTTOM TRACK TO FLOOR JOIST OR TRACK CONNECTION		
Exposure Category		Stud height, h (feet)		
B	C	$10 < h \leq 14$	$14 < h \leq 18$	$18 < h \leq 22$
115	—	1-No. 8 screw @ 12" o.c.	1-No. 8 screw @ 12" o.c.	1-No. 8 screw @ 12" o.c.
<u>426-120</u>	<u>440</u>	1-No. 8 screw @ 12" o.c.	1-No. 8 screw @ 12" o.c.	1-No. 8 screw @ 12" o.c.
<u><139-130</u>	115	1-No. 8 screw @ 12" o.c.	1-No. 8 screw @ 12" o.c.	2-No. 8 screws @ 12" o.c.
<u>— <140</u>	<u>426-120</u>	1-No. 8 screw @ 12" o.c.	<u>2</u> 1-No. 8 screws @ 12" o.c.	<u>4</u> 2-No. 8 screw @ <u>8"12"</u> o.c.
—	<u><139-130</u>	2-No. 8 screws @ 12" o.c.	1-No. 8 screw @ 8" o.c.	2-No. 8 screws @ 8" o.c.
<u>—</u>	<u>< 140</u>	<u>2</u> -No. 8 screws @ <u>12" o.c.</u>	<u>1</u> -No. 8 screw @ 8" o.c.	<u>2</u> -No. 8 screws @ 8" o.c.

For SI: 1 inch = 25.4 mm, 1 mile per hour = 0.447 m/s, 1 foot = 304.8 mm.

- Refer to Table R603.3.1.1(2) for gable endwall bottom track to foundation connections.
- Where attachment is not given, special design is required.
- Stud height, h , is measured from wall bottom track to wall top track or brace connection height.

TABLE R603.3.1.1 (2)
GABLE ENDWALL BOTTOM TRACK TO FOUNDATION CONNECTION REQUIREMENTS^{a, b, c}

ULTIMATE WIND SPEED (mph)		MINIMUM SPACING FOR $1/2$ -INCH-DIAMETER ANCHOR BOLTS ^d		
Exposure Category		Stud height, h (feet)		
B	C	$10 < h \leq 14$	$14 < h \leq 18$	$18 < h \leq 22$
115	—	6'-0" o.c.	<u>5'-7"6'-0"</u> o.c.	6'-0" o.c.
<u>426-120</u>	<u>440</u>	<u>5'-10"6'-0"</u> o.c.	<u>6'-0"5'-7"</u> o.c.	6'-0" o.c.
<u><139-130</u>	115	<u>4'-10"5'-0"</u> o.c.	<u>5'-6"6'-0"</u> o.c.	6'-0" o.c.
<u>— <140</u>	<u>426-120</u>	<u>4'-1"6'-0"</u> o.c.	<u>6'-0"5'-6"</u> o.c.	6'-0" o.c.
—	<u><139-130</u>	<u>5'-1"5'-3"</u> o.c.	6'-0" o.c.	<u>5'-2"6'-0"</u> o.c.

—	<140	3'- 0" o.c.	3'- 0" o.c.	3'- 0" o.c.
---	------	-------------	-------------	-------------

For SI: 1 inch = 25.4 mm, 1 mile per hour = 0.447 m/s, 1 foot = 304.8 mm.

- a. Refer to Table R603.3.1.1(1) for gable endwall bottom track to floor joist or track connection connections.
- b. Where attachment is not given, special design is required.
- c. Stud height, *h*, is measured from wall bottom track to wall top track or brace connection height.
- d. Foundation anchor straps are permitted in place of anchor bolts if spaced as required to provide equivalent anchorage to the required anchor bolts and installed in accordance with manufacturer's requirements.

TABLE R603.3.2 (2)
24-FOOT-WIDE BUILDING SUPPORTING ROOF AND CEILING ONLY^{a, b, c, d}

ULTIMATE WIND SPEED AND EXPOSURE CATEGORY (mph)		MEMBER SIZE	STUD SPACING (inches)	MINIMUM STUD THICKNESS (mils)												
				8-foot Studs				9-foot Studs				10-foot Studs				
Exp. B	Exp. C	Ground Snow Load (psf)														
		20	30	50	70	20	30	50	70	20	30	50	70			
115	—	350S162	16	33	33	33	33	33	33	33	33	33	33	33	33	
			24	33	33	33	43	33	33	33	43	33	33	43	43	
		550S162	16	33	33	33	33	33	33	33	33	33	33	33	33	33
			24	33	33	33	33	33	33	33	33	33	33	33	33	33 43
126-120	110	350S162	16	33	33	33	33	33	33	33	33	33	33	33	33	
			24	33	33	33	43	33	33	33	43	43	43	43		
		550S162	16	33	33	33	33	33	33	33	33	33	33	33	33	
			24	33	33	33	43	33	33	33	33	33	33	33	43	
<139 130	115	350S162	16	33	33	33	33	33	33	33	33	33	33	33	33	
			24	33	33	33 43	43	43	43	43	43	43	43	54		
		550S162	16	33	33	33	33	33	33	33	33	33	33	33	33	
			24	33	33	33	43	33	33	33	33 43	43 33	43 33	43 33	43	
— <140	126-120	350S162	16	33	33	33	33	33	33	33	33	33	43 33	43 33	43 33	43
			24	43 33	43 33	43	43	43	43	43	43	54	54	54	54	
		550S162	16	33	33	33	33	33	33	33	33	33	33	33	33	
			24	33	33	33	43	43 33	43 33	43 33	43	43	43	43	43	
—	<139 130	350S162	16	33	33	33	33	43 33	43 33	43 33	43 33	43 33	43	43	43	
			24	43	43	43	43	54	54	54	54	54	54	54		
		550S162	16	33	33	33	33	33	33	33	33	33	33	33	33	
			14	33	43 33	43 33	43	43	43	43	43	43	43	43	43	
=	<140	350S162	16	<u>33</u>	<u>33</u>	<u>33</u>	<u>33</u>	<u>43</u>	<u>43</u>	<u>43</u>	<u>43</u>	<u>43</u>	<u>43</u>	<u>43</u>	<u>43</u>	
			24	<u>43</u>	<u>43</u>	<u>43</u>	<u>54</u>	<u>54</u>	<u>54</u>	<u>54</u>	<u>54</u>	<u>54</u>	<u>54</u>	<u>54</u>		
		550S162	16	<u>33</u>	<u>33</u>	<u>33</u>	<u>33</u>	<u>33</u>	<u>33</u>	<u>33</u>	<u>33</u>	<u>33</u>	<u>33</u>	<u>33</u>	<u>33</u>	
			24	<u>43</u>	<u>43</u>	<u>43</u>	<u>43</u>	<u>43</u>	<u>43</u>	<u>43</u>	<u>43</u>	<u>43</u>	<u>43</u>	<u>43</u>	<u>43</u>	

For SI: 1 inch = 25.4 mm, 1 foot = 304.8 mm, 1 mil = 0.0254 mm, 1 mile per hour = 0.447 m/s, 1 pound per square foot = 0.0479 kPa, 1 ksi = 1,000 psi = 6.895 MPa.

a. Deflection criterion: $L/240$.

b. Design load assumptions:

Second-floor dead load is 10 psf.

Second-floor live load is 30 psf.

Roof/ceiling dead load is 12 psf.

Attic live load is 10 psf.

c. Building width is in the direction of horizontal framing members supported by the wall studs.

d. Minimum Grade 33 ksi steel shall be used for 33 mil and 43 mil thicknesses. Minimum Grade 50 ksi steel shall be used for 54 and 68 mil thicknesses.

TABLE R603.3.2 (3)
28-FOOT-WIDE BUILDING SUPPORTING ROOF AND CEILING ONLY^{a, b, c, d}

ULTIMATE WIND SPEED AND EXPOSURE CATEGORY (mph)		MEMBER SIZE	STUD SPACING (inches)	MINIMUM STUD THICKNESS (mils)													
				8-foot Studs				9-foot Studs				10-foot Studs					
				Ground Snow Load (psf)													
Exp. B	Exp. C			20	30	50	70	20	30	50	70	20	30	50	70		
115	—	350S162	16	33	33	33	33	33	33	33	33	33	33	33	33	33	
			24	33	33	43	43	33	33	43	43	33	33	43	33	43	54
		550S162	16	33	33	33	33	33	33	33	33	33	33	33	33	33	33
			24	33	33	33	43	33	33	33	43	33	33	33	33	33	43
126 120	110 —	350S162	16	33	33	33	33	33	33	33	33	33	33	33	33	33	
			24	33	33	43	43	33	33	43	43	43	43	43	43	54	
		550S162	16	33	33	33	33	33	33	33	33	33	33	33	33	33	33
			24	33	33	33	43	33	33	33	43	33	33	33	33	33	43
<139 130	115	350S162	16	33	33	33	33	33	33	33	33	33	33	33	33	43	
			24	33	33	43	43 54	43	43	43	43 54	43	43	43	54		
		550S162	16	33	33	33	33	33	33	33	33	33	33	33	33	33	
			24	33	33	33	43	33	33	33	43	43 33	43 33	43 33	43 33	43	
—<140	126 120	350S162	16	33	33	33	33	33	33	33	33	33	43 33	43 33	43 33	43	
			24	43 33	43 33	43	54	43	43	43	54	54	54	54	54		
		550S162	16	33	33	33	33	33	33	33	33	33	33	33	33	33	
			24	33	33	33	43	43 33	43 33	43 33	43	43	43	43	43		
—	<139 130	350S162	16	33	33	33	33	43 33	43 33	43 33	43	43	43	43	43		
			24	43	43	43	54	54	54	54	54	54	54	54			
		550S162	16	33	33	33	33	33	33	33	33	33	33	33	33		
			24	43 33	43 33	43 33	43	43	43	43	43	43	43	43	43		
=	< 140	350S162	16	33	33	33	43	43	43	43	43	43	43	43			
			24	43	43	43	54	54	54	54	54	54	54				
		550S162	16	33	33	33	33	33	33	33	33	33	33	33			

			<u>24</u>	<u>43</u>	<u>43</u>	<u>43</u>	<u>43</u>	<u>43</u>	<u>43</u>	<u>43</u>	<u>43</u>	<u>43</u>	<u>43</u>	<u>43</u>
--	--	--	-----------	-----------	-----------	-----------	-----------	-----------	-----------	-----------	-----------	-----------	-----------	-----------

For SI: 1 inch = 25.4 mm, 1 foot = 304.8 mm, 1 mil = 0.0254 mm, 1 mile per hour = 0.447 m/s, 1 pound per square foot = 0.0479 kPa, 1 ksi = 1,000 psi = 6.895 MPa.

a. Deflection criterion: $L/240$.

b. Design load assumptions:

Second-floor dead load is 10 psf.

Second-floor live load is 30 psf.

Roof/ceiling dead load is 12 psf.

Attic live load is 10 psf.

c. Building width is in the direction of horizontal framing members supported by the wall studs.

d. Minimum Grade 33 ksi steel shall be used for 33 mil and 43 mil thicknesses. Minimum Grade 50 ksi steel shall be used for 54 and 68 mil thicknesses.

TABLE R603.3.2 (4)
32-FOOT-WIDE BUILDING SUPPORTING ROOF AND CEILING ONLY^{a, b, c, d}

ULTIMATE WIND SPEED AND EXPOSURE CATEGORY (mph)		MEMBER SIZE	STUD SPACING (inches)	MINIMUM STUD THICKNESS (mils)											
				8-foot Studs				9-foot Studs				10-foot Studs			
Exp. B	Exp. C	Ground Snow Load (psf)													
		20	30	50	70	20	30	50	70	20	30	50	70		
115	—	350S162	16	33	33	33	33	33	33	33	33	33	33	33	33
			24	33	33	43	54	33	33	43	43 54	33 43	33 43	43	54
		550S162	16	33	33	33	33	33	33	33	33	33	33	33	33
			24	33	33	33	43	33	33	33	43	33	33	33	43
126-120	140 —	350S162	16	33	33	33	33	33	33	33	33	33	33	33	33
			24	33	33	43	54	33	33	43	54	43	43	43	54
		550S162	16	33	33	33	33	33	33	33	33	33	33	33	33
			24	33	33	33	43	33	33	33	43	33	33	33 43	43
<139 <u>130</u>	115	350S162	16	33	33	33	43	33	33	33	33	33 43	33	33	33
			24	33	33	43	54	43	43	43	43	54	43	43	43 54
		550S162	16	33	33	33	33	33	33	33	33	33	33	33	33
			24	33	33	33 43	43	33	33	33	43	43 33	43 33	43	43
— <140	126-120	350S162	16	33	33	33	43	33	33	33	33	43	43 33	43 33	43 33
			24	43 33	43 33	43	54	43	43	43	43	54	54	54	54
		550S162	16	33	33	33	33	33	33	33	33	33	33	33	33
			24	33	33	43	43	43 33	43 33	43 33	43	43	43	43	43
—	<139 <u>130</u>	350S162	16	33	33	33	43	43 33	43 33	43 33	43	43	43	43	43
			24	43	43	43	54	54	54	54	54	54	54	54	54
		550S162	16	33	33	33	33	33	33	33	33	33	33	33	33
			24	43 33	43 33	43	43	43	43	43	43	43	43	43	43
=	< 140	350S162	<u>16</u>	<u>33</u>	<u>33</u>	<u>33</u>	<u>43</u>	<u>43</u>	<u>43</u>	<u>43</u>	<u>43</u>	<u>43</u>	<u>43</u>	<u>43</u>	<u>43</u>
			<u>24</u>	<u>43</u>	<u>43</u>	<u>54</u>	<u>54</u>	<u>54</u>	<u>54</u>	<u>54</u>	<u>54</u>	<u>54</u>	<u>54</u>	<u>54</u>	<u>54</u>

		550S162	<u>16</u>	<u>33</u>	<u>33</u>	<u>33</u>	<u>33</u>	<u>33</u>	<u>33</u>	<u>33</u>	<u>33</u>	<u>33</u>	<u>33</u>	<u>33</u>	<u>33</u>
			<u>24</u>	<u>43</u>	<u>43</u>	<u>43</u>	<u>43</u>	<u>43</u>	<u>43</u>	<u>43</u>	<u>43</u>	<u>43</u>	<u>43</u>	<u>43</u>	<u>43</u>

For SI: 1 inch = 25.4 mm, 1 foot = 304.8 mm, 1 mil = 0.0254 mm, 1 mile per hour = 0.447 m/s, 1 pound per square foot = 0.0479 kPa, 1 ksi = 1,000 psi = 6.895 MPa.

- a. Deflection criterion: $L/240$.
- b. Design load assumptions:
 Second-floor dead load is 10 psf.
 Second-floor live load is 30 psf.
 Roof/ceiling dead load is 12 psf.
 Attic live load is 10 psf.
- c. Building width is in the direction of horizontal framing members supported by the wall studs.
- d. Minimum Grade 33 ksi steel shall be used for 33 mil and 43 mil thicknesses. Minimum Grade 50 ksi steel shall be used for 54 and 68 mil thicknesses.

TABLE R603.3.2 (5)
36-FOOT-WIDE BUILDING SUPPORTING ROOF AND CEILING ONLY^{a, b, c, d}

ULTIMATE WIND SPEED AND EXPOSURE CATEGORY (mph)		MEMBER SIZE	STUD SPACING (inches)	MINIMUM STUD THICKNESS (mils)												
				8-foot Studs				9-foot Studs				10-foot Studs				
				Ground Snow Load (psf)												
Exp. B	Exp. C			20	30	50	70	20	30	50	70	20	30	50	70	
115	—	350S162	16	33	33	33	43	33	33	33	43	33	33	33	43	
			24	33	33	43	54	33	33	43	54	33 43	43	54	54	
		550S162	16	33	33	33	33	33	33	33	33	33	33	33	33	33
			24	33	33	43	43	33	33	43	43	33	33	43	43	43
126 120	140	350S162	16	33	33	33	43	33	33	33	43	33	33	33	43	
			24	33	33	43	54	33	33	43	54	43	43	54	54	
		550S162	16	33	33	33	33	33	33	33	33	33	33	33	33	33
			24	33	33	43	43	33	33	43	43	33	33	43	43	43
139 130	115	350S162	16	33	33	33	43	33	33	33	33 43	33	33	43	43	
			24	33	33 43	43	54	43	43	43	43 54	43	43	54	54	
		550S162	16	33	33	33	33	33	33	33	33	33	33	33	33	33
			24	33	33	43	43	33	33	43	43	43 33	43 33	43	43	
140	126 120	350S162	16	33	33	33	43	33	33	33	43 33	33	33	43	43	
			24	43	43	43	54	43	43	43	54	54	54	54	54	
		550S162	16	33	33	33	33	33	33	33	33	33	33	33	33	33
			24	33	33	43	43	43 33	43 33	43	43	43	43	43	43	43 54
—	139 130	350S162	16	33	33	33	43	43 33	43 33	43 33	43	43	43	43	43	
			24	43	43	54	54	54	54	54	54	54	54	54	54	
		550S162	16	33	33	33	33	33	33	33	33	33	33	33	33	33 43
			24	43 33	43 33	43	54	43	33 43	43	43	43	43	43	43	54
=	<140	350S162	<u>16</u>	<u>33</u>	<u>33</u>	<u>33</u>	<u>43</u>	<u>43</u>	<u>43</u>	<u>43</u>	<u>43</u>	<u>43</u>	<u>43</u>	<u>43</u>	<u>54</u>	
			<u>24</u>	<u>43</u>	<u>43</u>	<u>54</u>	<u>54</u>	<u>54</u>	<u>54</u>	<u>54</u>	<u>54</u>	<u>54</u>	<u>54</u>	<u>54</u>	<u>68</u>	
		550S162	<u>16</u>	<u>33</u>	<u>33</u>	<u>33</u>	<u>33</u>	<u>33</u>	<u>33</u>	<u>33</u>	<u>33</u>	<u>33</u>	<u>33</u>	<u>33</u>	<u>43</u>	

			<u>24</u>	<u>43</u>	<u>43</u>	<u>43</u>	<u>54</u>	<u>43</u>	<u>43</u>	<u>43</u>	<u>43</u>	<u>43</u>	<u>43</u>	<u>43</u>	<u>54</u>
--	--	--	-----------	-----------	-----------	-----------	-----------	-----------	-----------	-----------	-----------	-----------	-----------	-----------	-----------

For SI: 1 inch = 25.4 mm, 1 foot = 304.8 mm, 1 mil = 0.0254 mm, 1 mile per hour = 0.447 m/s, 1 pound per square foot = 0.0479 kPa, 1 ksi = 1,000 psi = 6.895 MPa.

- a. Deflection criterion: $L/240$.
- b. Design load assumptions:
 Second-floor dead load is 10 psf.
 Second-floor live load is 30 psf.
 Roof/ceiling dead load is 12 psf.
 Attic live load is 10 psf.
- c. Building width is in the direction of horizontal framing members supported by the wall studs.
- d. Minimum Grade 33 ksi steel shall be used for 33 mil and 43 mil thicknesses. Minimum Grade 50 ksi steel shall be used for 54 and 68 mil thicknesses.

TABLE R603.3.2 (6)
40-FOOT-WIDE BUILDING SUPPORTING ROOF AND CEILING ONLY^{a, b, c, d}

ULTIMATE WIND SPEED AND EXPOSURE CATEGORY (mph)		MEMBER SIZE	STUD SPACING (inches)	MINIMUM STUD THICKNESS (mils)												
				8-foot Studs				9-foot Studs				10-foot Studs				
				Ground Snow Load (psf)												
Exp. B	Exp. C			20	30	50	70	20	30	50	70	20	30	50	70	
115	—	350S162	16	33	33	33	43	33	33	33	43	33	33	33 43	43	
			24	33	33	43	54	33	33 43	43	54	43	43	54	54	
		550S162	16	33	33	33	43	33	33	33	33	33	33	33	33	33
			24	33	33	43	54	33	33	43	43	43	33	33	43	54
126-120	110	350S162	16	33	33	33	43	33	33	33	43	33	33	43	43	
			24	33	43	43	54	33	43	43	54	43	43	54	54	
		550S162	16	33	33	33	43	33	33	33	33	33	33	33	33 43	43
			24	33	33	43	54	33	33	43	43	43	33	33	43	54
<139 130	115	350S162	16	33	33	33	43	33	33	33	43	33	33	43	43	
			24	33 43	43	43 54	54	43	43	43 54	54	43	43 54	54	54	
		550S162	16	33	33	33	43	33	33	33	33	33	33	33	33	43
			24	33	33	43	54	33	33	43	43 54	43 33	43 33	43	54	
—<140	126-120	350S162	16	33	33	33	43	33	33	33	43	43 33	43 33	43	43	
			24	43	43	54	54	43	43	54	54	54	54	54	54	
		550S162	16	33	33	33	43	33	33	33	33	33	33	33	33	43
			24	33	33	43	54	43 33	43 33	43	54	43	43	43	43	54
—	<139 130	350S162	16	33	33	43	43	43 33	43 33	43	43	43	43	43	54	
			24	43	43	54	54	54	54	54	54	54	54	54	68	
		550S162	16	33	33	33	43	33	33	33	33	43	33	33	33	43
			24	43 33	43 33	43	54	43	43	43	43	54	43	43	43	54
=	<140	350S162	16	<u>33</u>	<u>33</u>	<u>43</u>	<u>43</u>	<u>43</u>	<u>43</u>	<u>43</u>	<u>43</u>	<u>43</u>	<u>43</u>	<u>43</u>	<u>54</u>	
			24	<u>43</u>	<u>43</u>	<u>54</u>	<u>54</u>	<u>54</u>	<u>54</u>	<u>54</u>	<u>54</u>	<u>54</u>	<u>54</u>	<u>68</u>		
		550S162	16	<u>33</u>	<u>33</u>	<u>33</u>	<u>43</u>	<u>33</u>	<u>33</u>	<u>33</u>	<u>33</u>	<u>43</u>	<u>33</u>	<u>33</u>	<u>33</u>	<u>43</u>
			24	<u>43</u>	<u>43</u>	<u>33</u>	<u>43</u>	<u>33</u>	<u>33</u>	<u>33</u>	<u>33</u>	<u>43</u>	<u>33</u>	<u>33</u>	<u>33</u>	<u>43</u>

			<u>24</u>	<u>43</u>	<u>43</u>	<u>43</u>	<u>54</u>	<u>43</u>	<u>43</u>	<u>43</u>	<u>54</u>	<u>43</u>	<u>43</u>	<u>43</u>	<u>54</u>
--	--	--	-----------	-----------	-----------	-----------	-----------	-----------	-----------	-----------	-----------	-----------	-----------	-----------	-----------

For SI: 1 inch = 25.4 mm, 1 foot = 304.8 mm, 1 mil = 0.0254 mm, 1 mile per hour = 0.447 m/s, 1 pound per square foot = 0.0479 kPa, 1 ksi = 1,000 psi = 6.895 MPa.

- a. Deflection criterion: $L/240$.
- b. Design load assumptions:
 Second-floor dead load is 10 psf.
 Second-floor live load is 30 psf.
 Roof/ceiling dead load is 12 psf.
 Attic live load is 10 psf.
- c. Building width is in the direction of horizontal framing members supported by the wall studs.
- d. Minimum Grade 33 ksi steel shall be used for 33 mil and 43 mil thicknesses. Minimum Grade 50 ksi steel shall be used for 54 and 68 mil thicknesses.

TABLE R603.3.2 (7)
24-FOOT-WIDE BUILDING SUPPORTING ONE FLOOR, ROOF AND CEILING^{a, b, c, d}

ULTIMATE WIND SPEED AND EXPOSURE CATEGORY (mph)		MEMBER SIZE	STUD SPACING (inches)	MINIMUM STUD THICKNESS (mils)													
				8-foot Studs				9-foot Studs				10-foot Studs					
				Ground Snow Load (psf)													
Exp. B	Exp. C			20	30	50	70	20	30	50	70	20	30	50	70		
115	—	350S162	16	33	33	33	33	33	33	33	33	33	33	33	33	43	
			24	33	33	43	43	33 43	43	43	43	43	43	43	43	43	54
		550S162	16	33	33	33	33	33	33	33	33	33	33	33	33	33	33
			24	33	33	33	43	33	33	33	43	33	33	33	33	33	33
<u>126-120</u>	<u>110-115</u>	350S162	16	33	33	33	33	33	33	33	33	33	33	33	33	43	
			24	33 43	43	43	43	43	43	43	43	43	43	43	43 54	54	
		550S162	16	33	33	33	33	33	33	33	33	33	33	33	33	33	33
			24	33	33	33	43	33	33	33	43	33	33	33	33	33	43
130-130 <u>130</u>	115	350S162	16	33	33	33	43	33	33	33	33 43	33 43	33 43	43	43		
			24	43	43	43	43 54	43	43	43 54	43	54	54	54	54		
		550S162	16	33	33	33	33	33	33	33	33	33	33	33	33	33	
			24	33	33	33	43	33	33	33	43	43 33	43 33	43	43		
— <u><140</u>	<u>126-120</u>	350S162	16	33	33	33	43	33	33	33 43	43	43	43	43	43		
			24	43	43	43	54	43	43 54	54	54	54	54	54			
		550S162	16	33	33	33	33	33	33	33	33	33	33	33	33	33	
			24	33	33	33 43	43	43 33	43 33	43 33	43	43	43	43	43		
—	130-130 <u>130</u>	350S162	16	33	33	33	43	43	43	43	43	43	43	43	43 54		
			24	43	43	43 54	54	54	54	54	54	54	54	54			
		550S162	16	33	33	33	33	33	33	33	33	33	33	33	33		

			24	43 33	43 33	43	43	43	43	43	43	43	43	43		
=	<140	350S162	16	43	43	43	43	43	43	43	43	54	54	54	54	
			24	54	54	54	54	54	54	54	54	54	54	54	54	
		550S162	16	33	33	33	33	33	33	33	33	33	33	33	33	33
			24	43	43	43	43	43	43	43	43	43	43	43	43	43

For SI: 1 inch = 25.4 mm, 1 foot = 304.8 mm, 1 mil = 0.0254 mm, 1 mile per hour = 0.447 m/s, 1 pound per square foot = 0.0479 kPa, 1 ksi = 1,000 psi = 6.895 MPa.

- a. Deflection criterion: $L/240$.
- b. Design load assumptions:
 Second-floor dead load is 10 psf.
 Second-floor live load is 30 psf.
 Roof/ceiling dead load is 12 psf.
 Attic live load is 10 psf.
- c. Building width is in the direction of horizontal framing members supported by the wall studs.
- d. Minimum Grade 33 ksi steel shall be used for 33 mil and 43 mil thicknesses. Minimum Grade 50 ksi steel shall be used for 54 and 68 mil thicknesses.

TABLE R603.3.2 (8)
28-FOOT-WIDE BUILDING SUPPORTING ONE FLOOR, ROOF AND CEILING^{a, b, c, d}

ULTIMATE WIND SPEED AND EXPOSURE CATEGORY (mph)		MEMBER SIZE	STUD SPACING (inches)	MINIMUM STUD THICKNESS (mils)												
				8-foot Studs				9-foot Studs				10-foot Studs				
				Ground Snow Load (psf)												
Exp. B	Exp. C			20	30	50	70	20	30	50	70	20	30	50	70	
115	—	350S162	16	33	33	33	43	33	33	33	43	33	33	43	43	
			24	43	43	43	54	43	43	43	54	43	43	43 54	54	
		550S162	16	33	33	33	33	33	33	33	33	33	33	33	33	33
			24	33	33	43	43	33	33	43	43	33	33	43	43	
126-120	110—	350S162	16	33	33	33	43	33	33	33	43	33	33	43	43	
			24	43	43	43	54	43	43	43	54	43 54	43 54	54	54	
		550S162	16	33	33	33	33	33	33	33	33	33	33	33	33	33
			24	33	33	43	43	33	33	43	43	33	33	43	43	
<139 130	115	350S162	16	33	33	33	43	33	33	33 43	43	43	43	43	43	
			24	43	43	43	54	43	43 54	43 54	54	54	54	54	54	
		550S162	16	33	33	33	33	33	33	33	33	33	33	33	33	33
			24	33	33	43	43	33	33	43	43	43	43	43	43	43
—<140	126-120	350S162	16	33	33	33	43	33 43	33 43	43	43	43	43	43	43	
			24	43	43	43 54	54	54	54	54	54	54	54	54	54	
		550S162	16	33	33	33	33	33	33	33	33	33	33	33	33	33
			24	33	33	43	43	43 33	43 33	43	43	43	43	43	43	43
—	<139 130	350S162	16	33	33	43	43	43	43	43	43	43	43	43 54	54	
			24	43 54	43 54	54	54	54	54	54	54	54	54	54	54	
		550S162	16	33	33	33	33	33	33	33	33	33	33	33	33	33 43
			24	43 33	43 33	43	43	43	43	43	43	43	43	43	43	43
=	<140	350S162	16	43	43	43	43	43	43	43	43	43	54	54	54	54
			24	54	54	54	54	54	54	54	54	54	54	54	54	54

		<u>550S162</u>	<u>16</u>	<u>33</u>	<u>33</u>	<u>33</u>	<u>33</u>	<u>33</u>	<u>33</u>	<u>33</u>	<u>33</u>	<u>33</u>	<u>33</u>	<u>33</u>	<u>43</u>
			<u>24</u>	<u>43</u>	<u>43</u>	<u>43</u>	<u>43</u>	<u>43</u>	<u>43</u>	<u>43</u>	<u>43</u>	<u>43</u>	<u>43</u>	<u>43</u>	<u>54</u>

For SI: 1 inch = 25.4 mm, 1 foot = 304.8 mm, 1 mil = 0.0254 mm, 1 mile per hour = 0.447 m/s, 1 pound per square foot = 0.0479 kPa, 1 ksi = 1,000 psi = 6.895 MPa.

- a. Deflection criterion: $L/240$.
- b. Design load assumptions:
 Second-floor dead load is 10 psf.
 Second-floor live load is 30 psf.
 Roof/ceiling dead load is 12 psf.
 Attic live load is 10 psf.
- c. Building width is in the direction of horizontal framing members supported by the wall studs.
- d. Minimum Grade 33 ksi steel shall be used for 33 mil and 43 mil thicknesses. Minimum Grade 50 ksi steel shall be used for 54 and 68 mil thicknesses.

TABLE R603.3.2 (9)
32-FOOT-WIDE BUILDING SUPPORTING ONE FLOOR, ROOF AND CEILING^{a, b, c, d}

ULTIMATE WIND SPEED AND EXPOSURE CATEGORY (mph)		MEMBER SIZE	STUD SPACING (inches)	MINIMUM STUD THICKNESS (mils)												
				8-foot Studs				9-foot Studs				10-foot Studs				
Exp. B	Exp. C	Ground Snow Load (psf)														
		20	30	50	70	20	30	50	70	20	30	50	70			
115	—	350S162	16	33	33	33	43	33	33	33	43	33	33 43	43	43	
			24	43	43	43	54	43	43	43	54	43 54	43 54	54	54	
		550S162	16	33	33	33	43	33	33	33	33	33	33	33	33	43
			24	33	43	43	54	33	33	43	43	33	33	43	43	
126-120 140	—	350S162	16	33	33	33	43	33	33	33	43	33 43	43	43	43	
			24	43	43	43	54	43	43	43	54	54	54	54		
		550S162	16	33	33	33	43	33	33	33	33	33	33	33	43	
			24	33	43	43	54	33	33	43	43	33	33	43	43 54	
<139 130	115	350S162	16	33	33	43	43	33 43	33 43	33 43	43	43	43	43	43	
			24	43	43	54	54	43 54	43 54	54	54	54	54	54		
		550S162	16	33	33	33	43	33	33	33	33	33	33	33	43	
			24	33	43	43	54	33	33	43	43	43	43	43	54	
—<140	126-120	350S162	16	33	33	43	43	43	43	43	43	43	43	43	43 54	
			24	43	43 54	54	54	54	54	54	54	54	54	54		
		550S162	16	33	33	33	43	33	33	33	33 43	33	33	33	43	
			24	33	43	43	54	43 33	43	43	43	43	43	43	54	
—	<139 130	350S162	16	43	43	43	43	43	43	43	43	43	43 54	54	54	
			24	54	54	54	54	54	54	54	54	54	54	54		
		550S162	16	33	33	33	43	33	33	33	43	33	33	33	43	

			24	43	43	43	54	43	43	43	43	43 54	43	43	43	54
—	<140	350S162	16	43	43	43	43	43	43	43	43	54	54	54	54	54
			24	54	54	54	54	54	54	54	54	54	54	54	54	68
		550S162	16	33	33	33	43	33	33	33	43	33	33	33	33	43
			24	43	43	43	54	43	43	43	54	43	43	43	43	54

For SI: 1 inch = 25.4 mm, 1 foot = 304.8 mm, 1 mil = 0.0254 mm, 1 mile per hour = 0.447 m/s, 1 pound per square foot = 0.0479 kPa, 1 ksi = 1,000 psi = 6.895 MPa.

- a. Deflection criterion: $L/240$.
- b. Design load assumptions:
 Second-floor dead load is 10 psf.
 Second-floor live load is 30 psf.
 Roof/ceiling dead load is 12 psf.
 Attic live load is 10 psf.
- c. Building width is in the direction of horizontal framing members supported by the wall studs.
- d. Minimum Grade 33 ksi steel shall be used for 33 mil and 43 mil thicknesses. Minimum Grade 50 ksi steel shall be used for 54 and 68 mil thicknesses.

TABLE R603.3.2 (10)
36-FOOT-WIDE BUILDING SUPPORTING ONE FLOOR, ROOF AND CEILING^{a, b, c, d}

ULTIMATE WIND SPEED AND EXPOSURE CATEGORY (mph)		MEMBER SIZE	STUD SPACING (inches)	MINIMUM STUD THICKNESS (mils)											
				8-foot Studs				9-foot Studs				10-foot Studs			
Exp. B	Exp. C			Ground Snow Load (psf)											
				20	30	50	70	20	30	50	70	20	30	50	70
115	—	350S162	16	33	33	43	43	33	33	43	43	33 43	33 43	43	43
			24	43	43	54	54	43	43	54	54	54	54	54	54
		550S162	16	33	33	33	43	33	33	33	43	33	33	33	43
			24	43	43	43	54	43	43	43	54	43	43	43	54
126 120	110 —	350S162	16	33	33	43	43	33	33	43	43	43	43	43	43
			24	43	43	54	54	43	43	54	54	54	54	54	
		550S162	16	33	33	33	43	33	33	33	43	33	33	33	43
			24	43	43	43	54	43	43	43	54	43	43	43	54
139 130	115	350S162	16	33	33	43	43	33 43	33 43	43	43	43	43	43	54
			24	43	43 54	54	54	54	54	54	54	54	54	54	54 68
		550S162	16	33	33	33	43	33	33	33	43	33	33	33	43
			24	43	43	43	54	43	43	43	54	43	43	43	54
— <140	126 120	350S162	16	33 43	33 43	43	43	43	43	43	43	43	43	43	43 54
			24	54	54	54	54	54	54	54	54	54	54	54	68
		550S162	16	33	33	33	43	33	33	33	43	33	33	33	43
			24	43	43	43	54	43	43	43	54	43	43	43	54
—	139 130	350S162	16	43	43	43	43	43	43	43	43	43	43 54	54	54
			24	54	54	54	54	54	54	54	54	54	54	54	68
		550S162	16	33	33	33	43	33	33	33	43	33	33	33	43
			24	43	43	43	54	43	43	43	54	43	43	43	54

=	< 140	350S162	16	43	43	43	54	43	43	54	54	54	54	54	54
			24	54	54	54	54	54	54	54	54	54	54	54	54
		550S162	16	33	33	33	43	33	33	33	43	33	33	43	43
			24	43	43	43	54	43	43	43	54	43	43	54	54

For SI: 1 inch = 25.4 mm, 1 foot = 304.8 mm, 1 mil = 0.0254 mm, 1 mile per hour = 0.447 m/s, 1 pound per square foot = 0.0479 kPa, 1 ksi = 1,000 psi = 6.895 MPa.

a. Deflection criterion: $L/240$.

b. Design load assumptions:

Second-floor dead load is 10 psf.

Second-floor live load is 30 psf.

Roof/ceiling dead load is 12 psf.

Attic live load is 10 psf.

c. Building width is in the direction of horizontal framing members supported by the wall studs.

d. Minimum Grade 33 ksi steel shall be used for 33 mil and 43 mil thicknesses. Minimum Grade 50 ksi steel shall be used for 54 and 68 mil thicknesses.

TABLE R603.3.2 (11)
40-FOOT-WIDE BUILDING SUPPORTING ONE FLOOR, ROOF AND CEILING^{a, b, c, d}

ULTIMATE WIND SPEED AND EXPOSURE CATEGORY (mph)		MEMBER SIZE	STUD SPACING (inches)	MINIMUM STUD THICKNESS (mils)												
				8-foot Studs				9-foot Studs				10-foot Studs				
				Ground Snow Load (psf)												
Exp. B	Exp. C			20	30	50	70	20	30	50	70	20	30	50	70	
115	—	350S162	16	33	33	43	43	33	33	43	43	43	43	43	43	54
			24	43	43	54	54	43	43	54	54	54	54	54	54	54-68
		550S162	16	33	33	33	43	33	33	33	43	33	33	33	43	
			24	43	43	54	54	43	43	43	54	43	43	43	54	
426-120	410—	350S162	16	33	33	43	43	33	33	43	43	43	43	43	43	54
			24	43	43	54	54	43	43	54	54	54	54	54	54-68	
		550S162	16	33	33	33	43	33	33	33	43	33	33	33	43	
			24	43	43	54	54	43	43	43	54	43	43	43	54	
<139 130	115	350S162	16	33-43	33-43	43	43-54	43	43	43	43	43	43	43	43	54
			24	43-54	43-54	54	54	54	54	54	54	54	54	54	54	68
		550S162	16	33	33	43	43	33	33	33	43	33	33	33	43	
			24	43	43	54	54	43	43	43	54	43	43	43	54	
—<140	426-120	350S162	16	43	43	43	54	43	43	43	54	43	43	54	54	
			24	54	54	54	54	54	54	54	54	54	54	54	68	
		550S162	16	33	33	43	43	33	33	33	43	33	33	43	43	
			24	43	43	54	54	43	43	43	54	43	43	54	54	
—	<139 130	350S162	16	43	43	43	54	43	43	43	54	54	54	54	54	
			24	54	54	54	68	54	54	54	54	54	54	54	68	
		550S162	16	33	33	43	43	33	33	33	43	33	33	43	43	
			24	43	43	54	54	43	43	43	54	43	43	54	54	

=	<140	350S162	16	43	43	43	54	43	43	54	54	54	54	54	
			24	54	54	54	68	54	54	54	68	54	54	68	68
		550S162	16	33	33	43	43	33	33	43	43	33	43	43	43
			24	43	43	54	54	43	43	43	54	43	43	54	54

For SI: 1 inch = 25.4 mm, 1 foot = 304.8 mm, 1 mil = 0.0254 mm, 1 mile per hour = 0.447 m/s, 1 pound per square foot = 0.0479 kPa, 1 ksi = 1,000 psi = 6.895 MPa.

- a. Deflection criterion: $L/240$.
- b. Design load assumptions:
 Second-floor dead load is 10 psf.
 Second-floor live load is 30 psf.
 Roof/ceiling dead load is 12 psf.
 Attic live load is 10 psf.
- c. Building width is in the direction of horizontal framing members supported by the wall studs.
- d. Minimum Grade 33 ksi steel shall be used for 33 mil and 43 mil thicknesses. Minimum Grade 50 ksi steel shall be used for 54 and 68 mil thicknesses.

TABLE R603.3.2 (12)
24-FOOT-WIDE BUILDING SUPPORTING TWO FLOORS, ROOF AND CEILING^{a, b, c, d}

ULTIMATE WIND SPEED AND EXPOSURE CATEGORY (mph)		MEMBER SIZE	STUD SPACING (inches)	MINIMUM STUD THICKNESS (mils)												
				8-foot Studs				9-foot Studs				10-foot Studs				
				Ground Snow Load (psf)												
Exp. B	Exp. C			20	30	50	70	20	30	50	70	20	30	50	70	
115	—	350S162	16	43	43	43	43	33	33	33	43	43	43	43	43	
			24	54	54	54	54	43	43	54	54	54	54	54	54	
		550S162	16	33	33	43	43	33	33	33	33	33	33	33	33	43
			24	43	43	54	54	43	43	43	43	43	43	43	43	54
426-120	440—	350S162	16	43	43	43	43	33	33	33 43	43	43	43	43	43	
			24	54	54	54	54	54	54	54	54	54	54	54	54	
		550S162	16	33	33	43	43	33	33	33	33	33	33	33	33	43
			24	43	43	54	54	43	43	43	43	43	43	43	43	54
<139 130	115	350S162	16	43	43	43	43	43	43	43	43	43	43	43	43	43-54
			24	54	54	54	54	54	54	54	54	54	54	54	54	54
		550S162	16	33	33	43	43	33	33	33	33	33	33	33	33	43
			24	43	43	54	54	43	43	43	43	43	43	43	43	54
—<140	426-120	350S162	16	43	43	43	43	43	43	43	43	43	43	43	43	54
			24	54	54	54	54	54	54	54	54	54	54	54	54	54
		550S162	16	33	33	43	43	33	33	33	33	33	33	33	33	43
			24	43	43	54	54	43	43	43	43	43	43	43	43	54
—	<139 130	350S162	16	43	43	43	43	43	43	43	43	43	54	54	54	54
			24	54	54	54	54	54	54	54	54	54	54	54	54	68
		550S162	16	33	33	43	43	33	33	33	33	33	33	33	33	43
			24	43	43	54	54	43	43	43	43	43	43	43	43	54
=	<140	350S162	16	43	43	43	43	43	43	54	54	54	54	54	54	

			<u>24</u>	<u>54</u>	<u>54</u>	<u>54</u>	<u>54</u>	<u>54</u>	<u>54</u>	<u>54</u>	<u>54</u>	<u>54</u>	<u>54</u>	<u>68</u>	<u>68</u>
		<u>550S162</u>	<u>16</u>	<u>33</u>	<u>33</u>	<u>43</u>	<u>43</u>	<u>33</u>	<u>33</u>	<u>33</u>	<u>33</u>	<u>33</u>	<u>33</u>	<u>43</u>	<u>43</u>
			<u>24</u>	<u>43</u>	<u>43</u>	<u>54</u>	<u>54</u>	<u>43</u>	<u>43</u>	<u>43</u>	<u>43</u>	<u>43</u>	<u>54</u>	<u>54</u>	<u>54</u>

For SI: 1 inch = 25.4 mm, 1 foot = 304.8 mm, 1 mil = 0.0254 mm, 1 mile per hour = 0.447 m/s, 1 pound per square foot = 0.0479 kPa, 1 ksi = 1,000 psi = 6.895 MPa.

a. Deflection criterion: $L/240$.

b. Design load assumptions:

Top- and middle-floor dead load is 10 psf.

Top-floor live load is 30 psf.

Middle-floor live load is 40 psf.

Roof/ceiling dead load is 12 psf.

Attic live load is 10 psf.

c. Building width is in the direction of horizontal framing members supported by the wall studs.

d. Minimum Grade 33 ksi steel shall be used for 33 mil and 43 mil thicknesses. Minimum Grade 50 ksi steel shall be used for 54 and 68 mil thicknesses.

TABLE R603.3.2 (13)
28-FOOT-WIDE BUILDING SUPPORTING TWO FLOORS, ROOF AND CEILING^{a, b, c, d}

ULTIMATE WIND SPEED AND EXPOSURE CATEGORY (mph)		MEMBER SIZE	STUD SPACING (inches)	MINIMUM STUD THICKNESS (mils)													
				8-foot Studs				9-foot Studs				10-foot Studs					
Exp. B	Exp. C			Ground Snow Load (psf)													
				20	30	50	70	20	30	50	70	20	30	50	70		
115	—	350S162	16	43	43	43	43	43	43	43	43	43	43	43	43	43	
			24	54	54	54	54	54	54	54	54	54	54	54	54	54	
		550S162	16	43	43	43	43	43	43	43	43	43	43	43	43	43	43
			24	54	54	54	54	54	54	54	54	54	54	54	54	54	54
<u>126-120</u>	<u>110</u>	350S162	16	43	43	43	43	43	43	43	43	43	43	43	43	43	
			24	54	54	54	54	54	54	54	54	54	54	54	54	54	
		550S162	16	43	43	43	43	43	43	43	43	43	43	43	43	43	43
			24	54	54	54	54	54	54	54	54	54	54	54	54	54	54
<u><139</u> <u>130</u>	115	350S162	16	43	43	43	43	43	43	43	43	43	43	43	43 <u>54</u>	43 <u>54</u>	
			24	54	54	54	54	54	54	54	54	54	54	54	<u>54</u>	<u>68</u>	
		550S162	16	43	43	43	43	43	43	43	43	43	43	43	43	43	43
			24	54	54	54	54	54	54	54	54	54	54	54	54	54	54
<u><140</u>	<u>126-120</u>	350S162	16	43	43	43	43	43	43	43	43	43	43 <u>54</u>	43 <u>54</u>	54	54	
			24	54	54	54	54	54	54	54	54	54	54	54	<u>54</u>	<u>68</u>	
		550S162	16	43	43	43	43	43	43	43	43	43	43	43	43	43	43
			24	54	54	54	54	54	54	54	54	54	54	54	54	54	54
—	<u><139</u> <u>130</u>	350S162	16	43	43	43	43	43	43	43	43	43	43 <u>54</u>	54	54	54	
			24	54	54	54	54	54	54	54	54	54	54	54	54	54	
		550S162	16	43	43	43	43	43	43	43	43	43	43	43	43	43	43
			24	54	54	54	54	54	54	54	54	54	54	54	54	54	54
=	<u><140</u>	350S162	<u>16</u>	<u>43</u>	<u>43</u>	<u>43</u>	<u>54</u>	<u>54</u>	<u>54</u>	<u>54</u>	<u>54</u>	<u>54</u>	<u>54</u>	<u>54</u>	<u>54</u>		
			<u>24</u>	<u>54</u>	<u>54</u>	<u>54</u>	<u>54</u>	<u>54</u>	<u>54</u>	<u>54</u>	<u>68</u>	<u>68</u>	<u>68</u>	<u>68</u>	<u>68</u>		

		550S162	<u>16</u>	<u>43</u>	<u>43</u>	<u>43</u>	<u>43</u>	<u>43</u>	<u>43</u>	<u>43</u>	<u>43</u>	<u>43</u>	<u>43</u>	<u>43</u>
			<u>24</u>	<u>54</u>	<u>54</u>	<u>54</u>	<u>54</u>	<u>54</u>	<u>54</u>	<u>54</u>	<u>54</u>	<u>54</u>	<u>54</u>	<u>54</u>

For SI: 1 inch = 25.4 mm, 1 foot = 304.8 mm, 1 mil = 0.0254 mm, 1 mile per hour = 0.447 m/s, 1 pound per square foot = 0.0479 kPa, 1 ksi = 1,000 psi = 6.895 MPa.

- a. Deflection criterion: L/240.
- b. Design load assumptions:
 Top- and middle-floor dead load is 10 psf.
 Top-floor live load is 30 psf.
 Middle-floor live load is 40 psf.
 Roof/ceiling dead load is 12 psf.
 Attic live load is 10 psf.
- c. Building width is in the direction of horizontal framing members supported by the wall studs.
- d. Minimum Grade 33 ksi steel shall be used for 33 mil and 43 mil thicknesses. Minimum Grade 50 ksi steel shall be used for 54 and 68 mil thicknesses.

TABLE R603.3.2 (14)
32-FOOT-WIDE BUILDING SUPPORTING TWO FLOORS, ROOF AND CEILING^{a, b, c, d}

ULTIMATE WIND SPEED AND EXPOSURE CATEGORY (mph)		MEMBER SIZE	STUD SPACING (inches)	MINIMUM STUD THICKNESS (mils)																	
				8-foot Studs				9-foot Studs				10-foot Studs									
Exp. B Exp. C				Ground Snow Load (psf)																	
				20	30	50	70	20	30	50	70	20	30	50	70						
115	—	350S162	16	43	43	43	54	43	43	43	43	43	43	43	43	43	43	43	43	43	
			24	54	54	54	68	54	54	54	54	54	54	54	54	54	54	54	54	54	68
		550S162	16	43	43	43	43	43	43	43	43	43	43	43	43	43	43	43	43	43	43
			24	54	54	54	54	54	54	54	54	54	54	54	54	54	54	54	54	54	54
<u>126-120</u>	<u>110</u>	350S162	16	43	43	43	54	43	43	43	43	43	43	43	43	43	43	43	43	54	
			24	54	54	54	68	54	54	54	54	54	54	54	54	54	54	54	54	68	
		550S162	16	43	43	43	43	43	43	43	43	43	43	43	43	43	43	43	43	43	43
			24	54	54	54	54	54	54	54	54	54	54	54	54	54	54	54	54	54	54
<u><139</u> <u>130</u>	115	350S162	16	43	43	43	54	43	43	43	43	43	43 <u>54</u>	43 <u>54</u>	54	54	54	54	54	54	
			24	54	54	54	68	54	54	54	54	54	54	54 <u>68</u>	54 <u>68</u>	68	68	68	68		
		550S162	16	43	43	43	43	43	43	43	43	43	43	43	43	43	43	43	43	43	43
			24	54	54	54	54	54	54	54	54	54	54	54	54	54	54	54	54	54	54
<u>—<140</u>	<u>126-120</u>	350S162	16	43	43	43	54	43	43	43	43	43-54	54	54	54	54	54	54	54	54	
			24	54	54	54	68	54	54	54	54	54	68	68	68	68	68	68	68	68	
		550S162	16	43	43	43	43	43	43	43	43	43	43	43	43	43	43	43	43	43	43
			24	54	54	54	54	54	54	54	54	54	54	54	54	54	54	54	54	54	54
—	<u><139</u> <u>130</u>	350S162	16	43	43	43	54	43	43 <u>54</u>	54	54	54	54	54	54	54	54	54	54	54	
			24	54	54	54	68	54	54	54	54	54-68	68	68	68	68	68	68	68		
		550S162	16	43	43	43	43	43	43	43	43	43	43	43	43	43	43	43	43	43	43
			24	54	54	54	54	54	54	54	54	54	54	54	54	54	54	54	54	54	54
=	<u><140</u>	350S162	<u>16</u>	<u>43</u>	<u>43</u>	<u>54</u>	<u>54</u>	<u>54</u>	<u>54</u>	<u>54</u>	<u>54</u>	<u>54</u>	<u>54</u>	<u>54</u>	<u>54</u>	<u>54</u>	<u>54</u>	<u>54</u>	<u>54</u>	<u>54</u>	
			<u>24</u>	<u>54</u>	<u>54</u>	<u>54</u>	<u>68</u>	<u>54</u>	<u>68</u>	<u>68</u>	<u>68</u>	<u>68</u>	<u>68</u>	<u>68</u>	<u>68</u>	<u>68</u>	<u>68</u>	<u>68</u>	<u>68</u>	<u>68</u>	
		550S162	<u>16</u>	<u>43</u>	<u>43</u>	<u>43</u>	<u>43</u>	<u>43</u>	<u>43</u>	<u>43</u>	<u>43</u>	<u>43</u>	<u>43</u>	<u>43</u>	<u>43</u>	<u>43</u>	<u>43</u>	<u>43</u>	<u>43</u>	<u>43</u>	<u>43</u>
			<u>24</u>	<u>54</u>	<u>54</u>	<u>54</u>	<u>54</u>	<u>54</u>	<u>54</u>	<u>54</u>	<u>54</u>	<u>54</u>	<u>54</u>	<u>54</u>	<u>54</u>	<u>54</u>	<u>54</u>	<u>54</u>	<u>54</u>	<u>54</u>	<u>54</u>

For SI: 1 inch = 25.4 mm, 1 foot = 304.8 mm, 1 mil = 0.0254 mm, 1 mile per hour = 0.447 m/s, 1 pound per square foot = 0.0479 kPa, 1 ksi = 1,000 psi = 6.895 MPa.

a. Deflection criterion: $L/240$.

b. Design load assumptions:

Top- and middle-floor dead load is 10 psf.

Top-floor live load is 30 psf.

Middle-floor live load is 40 psf.

Roof/ceiling dead load is 12 psf.

Attic live load is 10 psf.

c. Building width is in the direction of horizontal framing members supported by the wall studs.

d. Minimum Grade 33 ksi steel shall be used for 33 mil and 43 mil thicknesses. Minimum Grade 50 ksi steel shall be used for 54 and 68 mil thicknesses.

TABLE R603.3.2 (15)
36-FOOT-WIDE BUILDING SUPPORTING TWO FLOORS, ROOF AND CEILING^{a, b, c, d}

ULTIMATE WIND SPEED AND EXPOSURE CATEGORY (mph)		MEMBER SIZE	STUD SPACING (inches)	MINIMUM STUD THICKNESS (mils)														
				8-foot Studs				9-foot Studs				10-foot Studs						
Exp. B	Exp. C			Ground Snow Load (psf)														
				20	30	50	70	20	30	50	70	20	30	50	70			
115	—	350S162	16	54	54	54	54	43	43	43	54	54	54	54	54	54	54	
			24	68	68	68	68	54	54	54	68	68	68	68	68	68	68	
		550S162	16	43	43	43	54	43	43	43	43	43	43	43	43	43	43	43
			24	54	54	54	54	54	54	54	54	54	54	54	54	54	54	54
126-120	140-144	350S162	16	54	54	54	54	43	43	43	54	54	54	54	54	54	54	
			24	68	68	68	68	54	54	54	68	68	68	68	68	68		
		550S162	16	43	43	43	54	43	43	43	43	43	43	43	43	43	43	43
			24	54	54	54	54	54	54	54	54	54	54	54	54	54	54	54
130	115	350S162	16	54	54	54	54	43	43	43	54	54	54	54	54	54	54	
			24	68	68	68	68	54	54	54	68	68	68	68	68	68		
		550S162	16	43	43	43	54	43	43	43	43	43	43	43	43	43	43	43
			24	54	54	54	54	54	54	54	54	54	54	54	54	54	54	54
140	126-120	350S162	16	54	54	54	54	43	43	54	54	54	54	54	54	54	54	
			24	68	68	68	68	54	54	54	68	68	68	68	68	68		
		550S162	16	43	43	43	54	43	43	43	43	43	43	43	43	43	43	43
			24	54	54	54	54	54	54	54	54	54	54	54	54	54	54	54
—	130	350S162	16	54	54	54	54	54	54	54	54	54	54	54	54	54	54	
			24	68	68	68	68	54	54	68	68	68	68	68	68	68		
		550S162	16	43	43	43	54	43	43	43	43	43	43	43	43	43	43	43
			24	54	54	54	54	54	54	54	54	54	54	54	54	54	54	54
=	140	350S162	16	54	54	54	54	54	54	54	54	54	54	54	54	54	54	
			24	68	68	68	68	68	68	68	68	68	68	68	68	68	68	
		550S162	16	43	43	43	54	43	43	43	43	43	43	43	43	43	43	43
			24	54	54	54	54	54	54	54	54	54	54	54	54	54	54	54

For SI: 1 inch = 25.4 mm, 1 foot = 304.8 mm, 1 mil = 0.0254 mm, 1 mile per hour = 0.447 m/s, 1 pound per square foot = 0.0479 kPa, 1 ksi = 1,000 psi = 6.895 MPa.

a. Deflection criterion: $L/240$.

b. Design load assumptions:

Top- and middle-floor dead load is 10 psf.

Top-floor live load is 30 psf.

Middle-floor live load is 40 psf.

Roof/ceiling dead load is 12 psf.

Attic live load is 10 psf.

c. Building width is in the direction of horizontal framing members supported by the wall studs.

d. Minimum Grade 33 ksi steel shall be used for 33 mil and 43 mil thicknesses. Minimum Grade 50 ksi steel shall be used for 54 and 68 mil thicknesses.

TABLE R603.3.2 (16)
40-FOOT-WIDE BUILDING SUPPORTING TWO FLOORS, ROOF AND CEILING^{a, b, c, d}

ULTIMATE WIND SPEED AND EXPOSURE CATEGORY (mph)		MEMBER SIZE	STUD SPACING (inches)	MINIMUM STUD THICKNESS (mils)													
				8-foot Studs				9-foot Studs				10-foot Studs					
Exp. B	Exp. C			Ground Snow Load (psf)													
				20	30	50	70	20	30	50	70	20	30	50	70		
115	—	350S162	16	54	54	54	54	54	54	54	54	54	54	54	54	54	54
			24	68	68	68	68	68	68	68	68	68	68	68	68	68	68
		550S162	16	54	54	54	54	43	43	54	54	43	43	54	54	54	54
			24	54	54	54	68	54	54	54	54	54	54	54	54	54	54
426120	440—	350S162	16	54	54	54	54	54	54	54	54	54	54	54	54	54	
			24	68	68	68	68	68	68	68	68	68	68	68	68		
		550S162	16	54	54	54	54	43	43	54	54	43	43	54	54	54	
			24	54	54	54	68	54	54	54	54	54	54	54	54	54	
<139130	115	350S162	16	54	54	54	54	54	54	54	54	54	54	54	54	54	
			24	68	68	68	68	68	68	68	68	68	68	68	68		
		550S162	16	54	54	54	54	43	43	54	54	43	43	54	54	54	
			24	54	54	54	68	54	54	54	54	54	54	54	54	54	
—<140	426120	350S162	16	54	54	54	54	54	54	54	54	54	54	54	54	54	
			24	68	68	68	68	68	68	68	68	68	68	68	68		
		550S162	16	54	54	54	54	43	43	54	54	43	43	54	54		
			24	54	54	54	68	54	54	54	54	54	54	54	54		
—	<139130	350S162	16	54	54	54	54	54	54	54	54	54	54	54	54		
			24	68	68	68	68	68	68	68	68	68	68	68			
		550S162	16	54	54	54	54	43	43	54	54	43	43	54	54		
			24	54	54	54	68	54	54	54	54	54	54	54	54		
=	<140	350S162	16	54	54	54	54	54	54	54	54	54	54	54	54		
			24	68	68	68	68	68	68	68	68	68	68	97			
		550S162	16	54	54	54	54	43	43	54	54	43	43	54	54		
			24	54	54	54	68	54	54	54	54	54	54	54	54		

For SI: 1 inch = 25.4 mm, 1 foot = 304.8 mm, 1 mil = 0.0254 mm, 1 mile per hour = 0.447 m/s, 1 pound per square foot = 0.0479 kPa, 1 ksi = 1,000 psi = 6.895 MPa.

a. Deflection criterion: $L/240$.

b. Design load assumptions:

Top and middle floor dead load is 10 psf.

Top floor live load is 30 psf.

Middle floor live load is 40 psf.

Roof/ceiling dead load is 12 psf.

Attic live load is 10 psf.

c. Building width is in the direction of horizontal framing members supported by the wall studs.

d. Minimum Grade 33 ksi steel shall be used for 33 mil and 43 mil thicknesses. Minimum Grade 50 ksi steel shall be used for 54 and 68 mil thicknesses.

TABLE R603.3.2.1 (1)
ALL BUILDING WIDTHS GABLE ENDWALLS 8, 9 OR 10 FEET IN HEIGHT^{a, b, c, d}

ULTIMATE WIND SPEED AND EXPOSURE CATEGORY (mph)		MEMBER SIZE	STUD SPACING (inches)	MINIMUM STUD THICKNESS (mils)		
				8-foot Studs	9-foot Studs	10-foot Studs
Exp. B	Exp. C					
115	—	350S162	16	33	33	33
			24	33	33	33
		550S162	16	33	33	33
			24	33	33	33
<u>426</u> <u>120</u>	<u>440</u> <u>—</u>	350S162	16	33	33	33
			24	33	33	43
		550S162	16	33	33	33
			24	33	33	33
<u><139</u> <u>130</u>	115	350S162	16	33	33	33
			24	33	33 <u>43</u>	43
		550S162	16	33	33	33
			24	33	33	33
<u>—</u> <u><140</u>	<u>426</u> <u>120</u>	350S162	16	33	33	33 <u>43</u>
			24	43 <u>33</u>	43	54
		550S162	16	33	33	33
			24	33	33	43 <u>33</u>
—	<u><139</u> <u>130</u>	350S162	16	33	43 <u>33</u>	43
			24	43	54 <u>43</u>	54
		550S162	16	33	33	33
			24	33	33 <u>43</u>	43
=	<u><140</u>	<u>350S162</u>	<u>16</u>	<u>33</u>	<u>43</u>	<u>43</u>
			<u>24</u>	<u>43</u>	<u>54</u>	<u>54</u>
		<u>550S162</u>	<u>16</u>	<u>33</u>	<u>33</u>	<u>33</u>
			<u>24</u>	<u>43</u>	<u>43</u>	<u>43</u>

For SI: 1 inch = 25.4 mm, 1 foot = 304.8 mm, 1 mil = 0.0254 mm, 1 mile per hour = 0.447 m/s, 1 pound per square foot = 0.0479 kPa, 1 ksi = 1,000 psi = 6.895 MPa.

a. Deflection criterion $L/240$.

b. Design load assumptions:

Ground snow load is 70 psf.

Roof/ceiling dead load is 12 psf.

Floor dead load is 10 psf.

Floor live load is 40 psf.

Attic dead load is 10 psf.

c. Building width is in the direction of horizontal framing members supported by the wall studs.

d. Minimum Grade 33 ksi steel shall be used for 33 mil and 43 mil thicknesses. Minimum Grade 50 ksi steel shall be used for 54 and 68 mil thicknesses.

TABLE R603.3.2.1 (2)
ALL BUILDING WIDTHS GABLE ENDWALLS OVER 10 FEET IN HEIGHT^{a, b, c, d}

ULTIMATE WIND SPEED AND EXPOSURE CATEGORY (mph)		MEMBER SIZE	STUD SPACING (inches)	MINIMUM STUD THICKNESS (mils)					
				Stud Height, h (feet)					
Exp. B	Exp. C			10 $h \leq 12$	12 $h \leq 14$	14 $h \leq 16$	16 $h \leq 18$	18 $h \leq 20$	20 $h \leq 22$
115	—	350S162	16	33	43	68	97	—	—
			24	43	68	—	—	—	—
		550S162	16	33	33	33	43	<u>54</u> <u>43</u>	54
			24	33	33 <u>43</u>	43	54	68	97
<u>126-120</u>	<u>110</u> <u>—</u>	350S162	16	43	54	97	—	—	—
			24	54	97	—	—	—	—
		550S162	16	33	33	43	<u>54</u> <u>43</u>	54	68
			24	33	43	54	54	68	97
139-130	115	350S162	16	43	68 <u>54</u>	97	—	—	—
			24	68 <u>54</u>	97	—	—	—	—
		550S162	16	33	43 <u>33</u>	43	54	68 <u>54</u>	97
			24	43	<u>54</u> <u>43</u>	54	68	97	97
140	<u>126-120</u>	350S162	16	<u>54</u> <u>43</u>	68	—	—	—	—
			24	68	—	—	—	—	—
		550S162	16	33	43	<u>54</u> <u>43</u>	54	68	97
			24	43	54	54	68	97	—
—	139-130	350S162	16	54	97	—	—	—	—
			24	97	—	—	—	—	—
		550S162	16	43 <u>33</u>	<u>54</u> <u>43</u>	54	68	97	—
			24	<u>54</u> <u>43</u>	54	68 <u>54</u>	97	—	—
=	<u><140</u>	<u>350S162</u>	<u>16</u>	<u>54</u>	<u>97</u>	=	=	=	=
			<u>24</u>	<u>97</u>	=	=	=	=	=
		<u>550S162</u>	<u>16</u>	<u>43</u>	<u>43</u>	<u>54</u>	<u>97</u>	<u>97</u>	=
			<u>24</u>	<u>54</u>	<u>54</u>	<u>68</u>	=	=	=

For SI: 1 inch = 25.4 mm, 1 foot = 304.8 mm, 1 mil = 0.0254 mm, 1 mile per hour = 0.447 m/s, 1 pound per square foot = 0.0479 kPa, 1 ksi = 1,000 psi = 6.895 MPa.

a. Deflection criterion $L/240$.

b. Design load assumptions:

Ground snow load is 70 psf.

Roof/ceiling dead load is 12 psf.

Floor dead load is 10 psf.

Floor live load is 40 psf.

Attic dead load is 10 psf.

c. Building width is in the direction of horizontal framing members supported by the wall studs.

d. Minimum Grade 33 ksi steel shall be used for 33 mil and 43 mil thicknesses. Minimum Grade 50 ksi steel shall be used for 54 and 68 mil thicknesses.

R603.3.5 Splicing. Steel studs and other structural members shall not be spliced without approved design. Tracks shall be spliced in accordance with Figure R603.3.5.

R603.6 Headers. Headers shall be installed above all wall openings in exterior walls and interior load-bearing walls. Box beam headers and back-to-back headers each shall be formed from two equal sized

C-shaped members in accordance with Figures R603.6(1) and R603.6(2), respectively, and Tables R603.6(1) through R603.6(6). L-shaped headers shall be permitted to be constructed in accordance with AISI S230. Alternately, headers shall be permitted to be designed and constructed in accordance with AISI S400, Section D4-S240.

TABLE R603.7 (2)
HEADER TO KING STUD CONNECTION REQUIREMENTS^{a, b, c, d}

HEADER SPAN (feet)	ULTIMATE WIND SPEED (mph), EXPOSURE CATEGORY					
	115 B	120 B	130 B	<140 B	130 C	<140 C
			115 C	120 C		
≤ 4'	4-No. 8 screws	4-No. 8 screws	4-No. 8 screws	4-No. 8 screws	6-No. 8 screws	6-No. 8 screws
> 4" to 8"	4-No. 8 screws	4-No. 8 screws	4-No. 8 screws	6-No. 8 screws	8-No. 8 screws	8-No. 8 screws
> 8" to 12"	4-No. 8 screws	6-No. 8 screws	6-No. 8 screws	8-No. 8 screws	10-No. 8 screws	12-No. 8 screws
> 12" to 16"	4-No. 8 screws	6-No. 8 screws	8-No. 8 screws	10-No. 8 screws	12-No. 8 screws	14-No. 8 screws

For SI: 1 inch = 25.4 mm, 1 foot = 304.8 mm, 1 mile per hour = 0.447 m/s, 1 pound = 4.448 N.

- All screw sizes shown are minimum.
- For headers located on the first floor of a two-story building or the first or second floor of a three-story building, the total number of screws is permitted to be reduced by 2 screws, but the total number of screws shall not be less than four.
- For roof slopes of 6:12 or greater, the required number of screws shall be permitted to be reduced by half, but the total number of screws shall not be less than four.
- Screws can be replaced by an uplift connector that has a capacity of the number of screws multiplied by 164 pounds.

R603.9.4.1 Ultimate design wind speeds greater than 126-130 mph. Where ultimate design wind speeds exceed 126-130 miles per hour (56-58 m/s), Exposure Category C walls shall be provided with direct uplift connections in accordance with AISI S230, Section E13.3, and AISI S230, Section F7.2-F8.2, as required for 139-140 miles per hour (62-63 m/s), Exposure Category C.

TABLE R603.8
HEAD AND SILL TRACK SPAN

ULTIMATE WIND SPEED AND EXPOSURE CATEGORY (mph)		ALLOWABLE HEAD AND SILL TRACK SPAN^{a, b, c} (feet-inches)					
		TRACK DESIGNATION^d					
B	C	350T125-33	350T125-43	350T125-54	550T125-33	550T125-43	550T125-54
115	—	4'-10" 5'-9"	5'-5" 6'-9"	6'-0" 9'-3"	5'-8" 7'-3"	6'-3" 9'-1"	6'-10" 12'-5"
126-120	110	4'-6" 5'-6"	5'-1" 6'-6"	5'-8" 8'-11"	5'-4" 7'-0"	5'-11" 8'-9"	6'-5" 11'-11"
<139-130	115	4'-2" 4'-10"	4'-9" 5'-9"	5'-4" 7'-10"	5'-1" 6'-2"	5'-7" 7'-8"	6'-1" 10'-6"
—<140	126-120	3'-11" 4'-8"	4'-6" 5'-6"	5'-0" 7'-6"	4'-10" 5'-11"	5'-4" 7'-4"	5'-10" 10'-1"
—	<139-130	3'-8" 4'-3"	4'-2" 5'-1"	4'-9" 6'-11"	4'-1" 5'-6"	5'-1" 6'-9"	5'-7" 9'-4"
—	≤ 140	4'-0"	4'-9"	6'-5"	5'-1"	6'-4"	8'-8"

For SI: 1 inch = 25.4 mm, 1 foot = 304.8 mm, 1 mile per hour = 0.447 m/s.

- Deflection limit: $L/240$.
- Head and sill track spans are based on components and cladding wind pressures and 48-inch tributary span.
- For openings less than 4 feet in height that have both a head track and sill track, the spans are permitted to be multiplied by 1.75. For openings less than or equal to 6 feet in height that have both a head track and a sill track, the spans are permitted to be multiplied by a factor of 1.5.
- Minimum Grade 33 ksi steel shall be used for 33 mil and 43 mil thicknesses. Minimum Grade 50 ksi steel shall be used for 54 and 68 mil thicknesses.

TABLE R603.9.2 (1)
MINIMUM PERCENTAGE OF FULL-HEIGHT STRUCTURAL SHEATHING ON EXTERIOR WALLS^{a, b}

WALL SUPPORTING	ROOF SLOPE	ULTIMATE WIND SPEED AND EXPOSURE (mph)					
		115 B	126 120 B	130 B	<140 B	<139	<140
			110 C	115 C	126 120 C	130 C	C
Roof and ceiling only (one story or top floor of two- or three-story building).	3:12	9	119	1142	1346	1720	20
	6:12	13	15	1720	2226	2835	35
	9:12	23	2725	2930	3350	5358	59
	12:12	3233	3935	40	4466	7075	76
One story, roof and ceiling (first floor of a two-story building or second floor of a three-story building).	3:12	2627	3230	3435	3950	5366	67
	6:12	2728	3330	3440	4458	6174	75
	9:12	38	4540	4655	6174	7894	92
	12:12	4345	5350	5765	72400	106445	116
Two stories, roof and ceiling (first floor of a three-story building).	3:12	4345	5354	5758	6484	89442	113
	6:12	4143	5145	5160	6790	95443	114
	9:12	53	6355	6380	8998	104124	126
	12:12	5457	6765	7490	100434	142455	157

For SI: 1 mph = 0.447 m/s.

a. Linear interpolation is permitted.

b. For hip-roofed homes the minimum percentage of full-height sheathing, based upon wind, is permitted to be multiplied by a factor of 0.95 for roof slopes not exceeding 7:12 and a factor of 0.9 for roof slopes greater than 7:12.

Reference standards type: This reference standard is new to the ICC Code Books
Add new standard(s) as follows:

AISI S240-15, North American Standard for Cold-Formed Steel Structural Framing (2015)

Standards are available for free download at www.aisistandards.org

Reason: This proposal is one in a series intended to update the content of the Cold-Formed Steel (CFS) light-framed construction provisions of the IRC. The proposed revisions align the IRC with the provisions of *AISI S230-15, Standard for Cold-Formed Steel Framing - Prescriptive Method for One- and Two-Family Dwellings*. The wind loads are adjusted to conform to the provisions of the ASCE7-10 Directional Method, and the wind speed increments are modified to correlate with the increments as shown in the wind speed maps (Figures R301.2(4)A and B). Member size and connection requirement tables are modified to correspond to the adjusted wind loads per methods specified in AISI S240 and AISI S100; respectively. Minor corrections have also been made to the text where applicable. Further explanation for each section follows:

Applicability Limits - This proposal adjusts the upper limit of the ultimate design wind speed from less than 139 miles per hour (mph) to less than 140 mph. The previous upper limit was based on a conversion of the wind speed from a nominal speed to an ultimate speed. For which, the conversion of the 110 mph nominal wind speed resulted in a rounded value of 139 mph ultimate wind speed upper limit (ie. less than 139 mph). This is detailed in the last cycle code change proposal RB258-13. Since the wind speeds now listed in this section are actual ultimate wind speeds, as derived from the ultimate wind speed maps, this section is now applicable for ultimate wind speeds up to 140 mph.

Tables R603.3.1 and R603.3.1.1(1) - Connection requirements are modified to accommodate corresponding wind load adjustments as previously stated.

Table R603.3.1.1(2) - Anchor spacing requirements are modified to accommodate corresponding wind load adjustments as previously stated.

Table R603.3.1.2(2) through Table R603.3.1.2(16) - Minimum stud thickness requirements are modified to accommodate corresponding wind load adjustments as previously stated.

Table R603.3.2.1(1) and Table R603.3.2.1(2) - Minimum stud thickness requirements are modified to accommodate corresponding wind load adjustments as previously stated.

Section R603.3.5 Splicing - Steel studs are permitted to be spliced with approved design per AISI S230.

Section R603.6 Headers - Previously this section referenced AISI S100, Section D4 for header design provisions. Section D4 of AISI S100 directed the user to *AISI S212 - North American Standard for Cold-Formed Steel Framing - Header Design*. However, the new standard **AISI S240**, *North American Standard for Cold-Formed Steel Structural Framing*, addresses requirements for construction with cold-formed steel structural framing that are common to prescriptive and engineered light frame construction. This comprehensive standard was formed by merging the following AISI standards:

- AISI S200, *North American Standard for Cold-Formed Steel Framing-General Provisions*
- AISI S210, *North American Standard for Cold-Formed Steel Framing-Floor and Roof System Design*
- AISI S211, *North American Standard for Cold-Formed Steel Framing-Wall Stud Design*
- AISI S212, *North American Standard for Cold-Formed Steel Framing-Header Design*
- AISI S213, *North American Standard for Cold-Formed Steel Framing-Lateral Design*
- AISI S214, *North American Standard for Cold-Formed Steel Framing-Truss Design*

Consequently, AISI S240 supersedes all previous editions of the above mentioned individual AISI standards and is the correct reference for this application.

Table R603.8 - Head and sill track allowable spans are modified to accommodate corresponding wind load adjustments as previously stated.

Table R603.9.2(1) - Minimum required percentages for full height sheathing are modified to accommodate corresponding wind load adjustments as previously stated.

The AISI Standards are available for free download at www.aisistandards.org

Cost Impact: Will increase the cost of construction

The proposed changes to this section will not increase the cost of construction in general. While the overwhelming majority of the prescribed members have not changed or are reduced in size, there may be conditions for which the minimum member size will increase.

Analysis: A review of the standard(s) proposed for inclusion in the code, AISI 240-15, with regard to the ICC criteria for referenced standards (Section 3.6 of CP#28) will be posted on the ICC website on or before April 1, 2016.

Report of Committee Action Hearings
--

Committee Action:

Approved as Submitted

Committee Reason: This change aligns the cold-formed steel wall framing provisions with the new referenced cold-formed steel structural framing standard.

Also, the applicable design wind speed is changed to less than 140 mph ultimate. The framing tables are revised to reflect the wind load increase and to align with ASCE 7-10. Directional Method.

Assembly Action:

None

Final Action Results

RB248-16

AS

Code Change No: **RB249-16**

Original Proposal

Section: R606.1

Proponent: Jason Thompson, Masonry Alliance for Codes and Standards (MACS), representing Masonry Alliance for Codes and Standards (jthompson@ncma.org); Phillip Samblanet, representing The Masonry Society (psamblanet@masonrysociety.org)

Revise as follows:

R606.1 General. Masonry construction shall be designed and constructed in accordance with the provisions of this section, TMS 402, TMS 403, or in accordance with the provisions of TMS 402/ACI 530/ASCE 5-404.

Reference standards type: This reference standard is new to the ICC Code Books
Add new standard(s) as follows:

TMS 404-16 – Standard for the Design of Architectural Cast Stone

Reason: Architectural cast stone is a non-structural masonry system typically used as architectural accents such as balusters, quoins, sills, etc. While generally covered within the masonry requirements of the IRC, the vast majority of design, fabrication, and installation guidance for these systems has historically stemmed from industry-generated best practices; a gap now filled with the creation of these three new standards.

Topics covered collectively under these three new standards include:

- 1) Minimum requirements for reinforcement, ties, and anchors used with cast stone along with the associated corrosion protection requirements for these materials.
- 2) Additional requirements for cast stone materials not covered within ASTM C1364.
- 3) Tolerance requirements for individual cast stone elements as well as finished assemblies.
- 4) Information to be included in shop drawings and submittal packages.
- 5) Ancillary materials used during the installation of cast stone including mortar, grout, and jointing materials.
- 6) Minimum quality assurance requirements including testing frequency, sample panels, and inspection.
- 7) Installation criteria for both wet-setting (laying cast stone elements in mortar) as well as dry-setting (where cast stone units are shimmed and caulked).

Cost Impact: Will not increase the cost of construction

The addition of these news standards is an alternative to the existing IRC provisions based on existing industry best practices.

Report of Committee Action Hearings

Committee Action:

Approved as Submitted

Committee Reason: This proposal brings the current standard for design and installation of architectural cast stone into the IRC..

Assembly Action:

None

Final Action Results

RB249-16

AS

Code Change No: **RB254-16**

Original Proposal

Section: R609.2

Proponent: Jeff Inks, representing Window & Door Manufacturers Association (jinks@wdma.com)

Revise as follow:

R609.2 Performance. Exterior windows and doors shall be ~~designed to resist~~capable of resisting the design wind loads specified in Table R301.2(2) adjusted for height and exposure in accordance with Table R301.2(3) or determined in accordance with ASCE 7 ~~using the allowable stress.~~ For exterior windows and doors tested in accordance with Sections R609.3 and R609.5, required design load combinations of wind pressures determined from ASCE 7 ~~are permitted to be multiplied by 0.6.~~ Design wind loads for exterior glazing not part of a labeled assembly shall be permitted to be determined in accordance with Chapter 24 of the *International Building Code*.

Reason: This proposal is intended to clarify that the use of the 0.6 conversion multiplier is allowed with respect to the determination of design wind pressures in accordance with ASCE 7 and testing of the respective assemblies in accordance with Section R609.3 or R609.5 accordingly. While that is what the existing provision allows, as currently written, that is not entirely clear and has led to confusion regarding wind load requirements. This proposed amendment expressly states that the use of 0.6 multiplier is allowed and will alleviate the confusion that currently exists benefiting all – code officials, manufacturers and builders.

Cost Impact: Will not increase the cost of construction
This is a clarification. No substantive change.

Report of Committee Action Hearings

Committee Action:

Approved as Modified

Modify as follows:

R609.2 Performance. Exterior windows and doors shall be capable of resisting the design wind loads specified in Table R301.2(2) adjusted for height and exposure in accordance with Table R301.2(3) or determined in accordance with ASCE 7 . For exterior windows and doors tested in accordance with Sections R609.3 and R609.5, required design wind pressures determined from ASCE 7 using the ultimate strength design (USD) are permitted to be multiplied by 0.6. Design wind loads for exterior glazing not part of a labeled assembly shall be permitted to be determined in accordance with Chapter 24 of the *International Building Code*.

Committee Reason: The committee approved this proposal based on the proponents published reason statement. The windows and doors are being tested to allowable stress design and the 0.6 is the appropriate multiplier to apply to the ultimate strength design. The modification clarifies where the 0.6 multiplier is to be applied.

Assembly Action

None

Final Action Results

RB254-16

AM

Code Change No: **RB259-16**

Original Proposal

Section: R202 (New), R609.6, R609.6.1, R609.6.2 (New)

Proponent: T. Eric Stafford, PE, representing Institute for Business and Home Safety

Add new definition as follows:

Impact Protective System Construction that has been shown by testing to withstand the impact of test missiles and that is applied, attached, or locked over exterior glazing.

Revise as follows:

R609.6 Wind-borne debris protection. Protection of exterior windows ~~and~~ glass doors, ~~and~~ doors with glass in buildings located in wind-borne debris regions shall be in accordance with Section R301.2.1.2.

R609.6.1 Fenestration testing and labeling. Fenestration shall be tested by an *approved* independent laboratory, listed by an *approved* entity, and bear a *label* identifying manufacturer, performance characteristics, and *approved* inspection agency to indicate compliance with the requirements of the following specification(s):

1. ASTM E 1886 and ASTM E 1996; or
2. AAMA 506.

Add new text as follows:

R609.6.2 Impact protective systems testing and labeling Impact protective systems shall be tested for impact resistance by an approved independent laboratory for compliance with ASTM E 1886 and ASTM E 1996. Impact protective systems shall also be tested for design wind pressure by an approved independent laboratory for compliance with ASTM E 330. Required design wind pressures shall be determined in accordance with Table R301.2(2) adjusted for height and exposure in accordance with Table R301.2(3) or determined in accordance with ASCE 7. For the purposes of this section, design wind pressures determined in accordance with ASCE 7 are permitted to be multiplied by 0.6.

Impact protective systems bear a label identifying the manufacturer, performance characteristics, and approved inspection agency. Impact protective systems shall have a permanent label providing traceability to the manufacturer, product designation, and performance characteristics. The permanent label shall be acid etched, sand blasted, ceramic fired, laser etched, embossed or of a type that, once applied, cannot be removed without being destroyed.

Reason: This proposal is one of several that are addressing labeling of critical components of the building envelope. The primary purpose of this code change is to require that impact protective systems (hurricane shutters) have a permanent label that provides a way for building owners, homeowners, and others to be able to determine their performance characteristics after the building has been occupied. The 2015 IRC does not require any type of label for impact protective systems. For products that don't have permanent labels, it becomes nearly impossible for the owner to determine the structural wind load resistance and impact resistance of the products after they've occupied the building. This proposal would simply require some type of permanent marking on the impact protective system indicating the manufacturer and model/series number, and performance characteristics so that the specific performance characteristics could be retrieved at a later date. The permanent label would only need to provide traceability to the product. However, it could provide all the required information. If the relevant information is not provided on a permanent label, a temporary removable label is required to be applied so that local code officials can verify that the appropriate impact protective system was provided.

For the past 10-15 years, there has been a push towards considering sustainability in the way our buildings are constructed in this country. If this goal is to be successful and building owners and occupants increasingly want more information about the

sustainability of the buildings they occupy, they need to be provided ways to be able to determine how critical components are expected to perform in the buildings they use. Impact protective systems are important components of the building envelope and their performance is critical to maintaining the overall structural integrity of the building. Some manufacturers already include permanent labels on their products that provide traceability to the manufacture and the product characteristics. The Florida Building Code has required a permanent label since the 2007 edition and has continued to require it in subsequent editions. The following is the relevant text from the 5th Edition (2014) Florida Building Code, Residential:

R615.1 Impact resistant coverings shall be tested at 1.5 times the design pressure (positive or negative) expressed in pounds per square feet as determined by the Florida Building Code, Building Section 1609 for which the specimen is to be tested. The design pressures, as determined from Section 1609 of the Florida Building Code, Building or ASCE 7, are permitted to be multiplied by 0.6.

R615.1.1 Impact resistant coverings shall be labeled in accordance with the provisions of Section R615.

R615.2. Labels. A permanent label shall be provided by the product approval holder on all impact resistant coverings.

Another consideration is that insurance incentives are now being offered in several states for homes, new and existing, that comply with certain levels of the Fortified program administered by IBHS. The Fortified program is a set of engineering and building standards designed to help strengthen new and existing homes through system-specific building upgrades to minimum building code requirements that will reduce damage from specific natural hazards. Fortified offers three different levels of designation (bronze, silver, and gold) depending on the extent of the recommended "upgrades" to the building's wind resistance. To qualify for a designation, the home has to be inspected. Without a permanent label providing traceability to the manufacturer and product, the performance characteristics often cannot be determined, and certain Fortified designations become difficult or impossible to be given.

This proposal also provides some additional clarification for impact protective systems that is lacking in the IRC. New Section R609.6.2 clarifies that impact protective systems also have to be capable of resisting the required design wind pressure as well as the impact criteria. New language is added to clarify the relationship between design wind loads calculated in accordance with ASCE 7-10 and the wind load testing requirements of ASTM E 330.

Approval of this proposal will assure, going forward, that new or replaced impact protective systems will be labeled such that building owners and those considering the purchase of buildings with these products will be able to obtain information necessary for determining the expected performance of these critical components used to protect the building envelope in hurricane prone areas.

Cost Impact: Will increase the cost of construction

Will result in an increase in cost. A consultant representing the industry estimates the cost of providing labels on impact resistant covering products to be as follows:

- a. Water Resistant Self-adhering Permanent Labels approximately \$0.15 per label. Such labels would most likely be used on Accordion, Roll, Bahama, and Colonial style shutters.
- b. Embossed or ink jet labels used on metal and plastic panels would cost approximately \$0.05 per label.

Report of Committee Action Hearings

Committee Action:

Approved as Submitted

Committee Reason: This is a needed change because it is difficult to identify whether a hurricane shutter or impact protective system meets the code specified requirements. Requiring a permanent label will alleviate this problem.

Assembly Action:

None

Final Action Results

RB259-16

AS

Code Change No: **RB260-16**

Original Proposal

Section: R702.2.1

Proponent: G Michael Starks, In-Spex, LLC, C B Goldsmith & assoc., FloridaLath & Plaster Bureau, representing In-Spex, LLC (mstarks@in-spexllc.com)

Revise as follows:

R702.2.1 Gypsum plaster. Gypsum plaster materials shall conform to ASTM C 5, C 22, C 28, C 35, C 59, C 61, C 587, C 631, C 847, C 933, C 1032 and C 1047, and shall be installed or applied in compliance with ASTM ~~C841~~, ~~C 843~~~~842~~ and ~~C 844~~~~843~~. Gypsum lath or gypsum base for veneer plaster shall conform to ASTM C 1396 and shall be installed in compliance with ASTM C 844. Plaster shall be not less than three coats where applied over metal lath and not less than two coats where applied over other bases permitted by this section, except that veneer plaster shall be applied in one coat not to exceed $3/16$ inch (4.76 mm) thickness, provided the total thickness is in accordance with Table R702.1(1).

Reference standards type: This reference standard is new to the ICC Code Books
Add new standard(s) as follows:

ASTM C 841-03 (Reapproved 2013) Standard Specification for Installation of Interior Lathing and Furring;
ASTM C 842-05 (Reapproved 2015) Standard Specification for Application of Interior Gypsum Plaster;

Reason: As currently written, the Code eliminates the use of full-depth plaster in favor of veneer plaster. However, the values in Table R702.1(1) Thickness of Plaster, reflect the values of ASTM C 842, *Standard Specification for Application of Interior Gypsum Plaster*. Thickness values for C 843, *Standard Specification for Application of Gypsum Veneer Plaster*, are much thinner. In addition, application of gypsum base is covered in the current reference standard, ASTM C 844.

Bibliography: ASTM C 841-03 (Reapproved 2013) *Standard Specification for Installation of Interior Lathing and Furring* -
 w w w .astm.org
 ASTM C 842-05 (Reapproved 2015) *Standard Specification for Application of Interior Gypsum Plaster*, pg 2,
 w w w .astm.org
 ASTM C 843-99 (Reapproved 2012) *Standard Specification for Application of Gypsum Veneer Plaster*, pg 3,
 w w w .astm.org

Cost Impact: Will not increase the cost of construction
 There is no cost of construction significance in this item.

Analysis: A review of the standard(s) proposed for inclusion in the code, ASTM C841-03 and ASTM 842-05, with regard to the ICC criteria for referenced standards (Section 3.6 of CP#28) will be posted on the ICC website on or before April 1, 2016.

Report of Committee Action Hearings

Committee Action:

Approved as Submitted

Committee Reason: The committee approved this proposal based on the proponents published reason statement.

Assembly Action:

None

Final Action Results

RB260-16

AS

Code Change No: **RB261-16**

Original Proposal

Section: R702.2.2

Proponent: G Michael Starks, In-Spex, LLC, C B Goldsmith & assoc., Florida Lath & Plaster Bureau, representing In-Spex, LLC (mstarks@in-spexllc.com)

Revise as follows:

R702.2.2 Cement plaster. Cement plaster materials shall conform to ASTM C 91 (Type M, S or N), C 150 (Type I, II and III), C 595 [Type IP, I (PM), IS and I (SM), C 847, C 897, ~~C 926,~~ C 933, C 1032, C 1047 and C 1328, and shall be installed or applied in compliance with ASTM C 926 and C 1063. Gypsum lath shall conform to ASTM C 1396. Plaster shall be not less than three coats where applied over metal lath and not less than two coats where applied over other bases permitted by this section, ~~except that veneer plaster shall be applied in one coat not to exceed $\frac{3}{16}$ inch (4.76 mm) thickness, provided the total thickness is in accordance with Table R702.1(1).~~

Reason: Currently there is an misplacement error in the reference standards as listed in the current section. ASTM C 926, Standard Specification for Application of Portland Cement-Based Plaster, is an application standard and belongs after "...in compliance with" prior to "ASTM C 1063."

Bibliography: ASTM C 926-13 *Standard specification for Application of Portland Cement-Based Plaster*;

Cost Impact: Will not increase the cost of construction
There is no cost of construction significance in this item.

Report of Committee Action Hearings

Committee Action:

Approved as Submitted

Committee Reason: The proposal corrects a standard pointer to the installation portion and eliminates erroneous statements about the veneer thickness at the end of the section.

Assembly Action:

None

Final Action Results

RB261-16

AS

Code Change No: **RB264-16**

Original Proposal

Section: R702.3.1

Proponent: Mike Fischer, Kellen, representing The Gypsum Association, representing Gypsum Association (mfischer@kellencompany.com)

Revise as follows:

R702.3.1 Materials. Gypsum board and gypsum panel product materials and accessories shall conform to ASTM C 22, C 475, C 514, C 1002, C 1047, C 1177, C 1178, C 1278, C 1396 ~~or~~, C 1658, or C1766, and shall be installed in accordance with the provisions of this section. Adhesives for the installation of gypsum board and gypsum panel products shall conform to ASTM C 557.

Reference standards type: This reference standard is new to the ICC Code Books
Add new standard(s) as follows:

ASTM C 1766-13 Standard Specification for Factory-Laminated Gypsum Panel Products

Reason: ASTM C1766 was developed by ASTM subcommittee C11.01, assigned the responsibility for the development and maintenance of test methods and materials for gypsum products. Standard C 1766 addresses gypsum panel products, laminated in the factory, that are designed for use in sound control (in ceilings, walls, partitions etc.) or for gypsum studs or coreboards. Adding the standard to R702.3.1 will help ensure that the latest available information and product standards for these panels are appropriately applied.

Cost Impact: Will not increase the cost of construction

The proposal adds in a product standard that extends performance requirements for factory-laminated products to meet the current intent of the code. The proposal increases product selection options, but contains no mandatory requirements.

Analysis: A review of the standard(s) proposed for inclusion in the code, ASTM C1766-13, with regard to the ICC criteria for referenced standards (Section 3.6 of CP#28) will be posted on the ICC website on or before April 1, 2016.

Report of Committee Action Hearings

Committee Action:

Approved as Submitted

Committee Reason: The proposal adds an appropriate new standard for a specific gypsum panel product.

Assembly Action:

None

Final Action Results

RB264-16

AS

Code Change No: **RB265-16**

Original Proposal

Section: R702.3.3

Proponent: Jon-Paul Cardin, American Iron and Steel Institute, representing American Iron and Steel Institute (JCardin@steel.org)

Revise as follows:

R702.3.3 Cold-formed steel framing. Cold-formed steel framing supporting gypsum board and gypsum panel products shall be not less than 1 1/4 inches (32 mm) wide in the least dimension. Nonload-bearing cold-formed steel framing shall comply with AISI S220 and ASTM C645, Section 10. Load-bearing cold-formed steel framing shall comply with AISI S200 and ASTM C 955, Section 8 ~~S240~~.

Reference standards type: This reference standard is new to the ICC Code Books
Add new standard(s) as follows:

AISI S240-15, North American Standard for Cold-Formed Steel Structural Framing (2015)

Standards Available for free download at www.aisistandards.org

Reason: This proposal is one in a series intended to update the content of the cold-formed steel (CFS) light-framed construction provisions of the IRC. The screw penetration test, as referenced to ASTM C645, Section 10, has been incorporated into AISI S220-15, *North American Standard for Cold-Formed Steel Framing - Non-Structural Members*. Therefore, the reference to AISI S220 is adequate to cover those requirements.

In addition, this section previously referenced AISI S200 for load-bearing cold-formed steel framing. However, the new standard **AISI S240**, *North American Standard for Cold-Formed Steel Structural Framing*, addresses requirements for construction with cold-formed steel structural framing that are common to prescriptive and engineered light frame construction. This comprehensive standard was formed by merging the following AISI standards:

- *AISI S200, North American Standard for Cold-Formed Steel Framing-General Provisions*
- *AISI S210, North American Standard for Cold-Formed Steel Framing-Floor and Roof System Design*
- *AISI S211, North American Standard for Cold-Formed Steel Framing-Wall Stud Design*
- *AISI S212, North American Standard for Cold-Formed Steel Framing-Header Design*
- *AISI S213, North American Standard for Cold-Formed Steel Framing-Lateral Design*
- *AISI S214, North American Standard for Cold-Formed Steel Framing-Truss Design*

Consequently, AISI S240 supersedes all previous editions of the above mentioned individual AISI standards and is the correct reference for this application.

The additional screw penetration test, as referenced to ASTM C955 Section 8, is intended for load-bearing CFS framing members. Through the ANSI approved process of developing AISI S240-15, it was the consensus of the AISI Committee on Framing Standards that the screw penetration test was not necessary for load-bearing CFS framing members. The basis of the determination is that the test never produced a failed result for the thickness of members used in structural framing applications. Therefore, the screw penetration test of ASTM C955 Section 8 was not included in AISI S240-15, and is not required as a separate reference in this section of the IRC.

Cost Impact: Will not increase the cost of construction

This proposal is intended to update the referenced AISI standards and does not effect the intended prescribed construction requirements.

Analysis: A review of the standard(s) proposed for inclusion in the code, AISI 240-15, with regard to the ICC criteria for referenced standards (Section 3.6 of CP#28) will be posted on the ICC website on or before April 1, 2016.

**Report of Committee Action
Hearings**

Committee Action:

Approved as Submitted

Committee Reason: The committee approved this proposal based on the proponents published reason statement. The new standard merged 6 standards into one and eliminated the need to reference some standards since the requirements are in the new standard..

Assembly Action:

None

Final Action Results

RB265-16

AS

Code Change No: RB276-16**Original Proposal****Section: R702.7.3**

Proponent: Matthew Dobson, Vinyl Siding Institute, representing Vinyl Siding Institute

Revise as follows:

R702.7.3 Minimum clear airspaces and vented openings for vented cladding. For the purposes of this section, vented cladding shall include the following minimum clear airspaces. Other openings with the equivalent vent area shall be permitted.

1. Vinyl-lap, polypropylene, or horizontal aluminum siding applied over a weather-resistive barrier as specified in Table R703.3(1).
2. Brick veneer with a clear airspace as specified in Table R703.8.4.
3. Other approved vented claddings.

Reason: Polypropylene siding is very similar to vinyl siding in its shape and design and has similar "vented cladding" characteristics. We are asking for recognition of this with respect to vapor barriers.

Below are photos of a typical vinyl siding profile and a typical polypropylene siding profile. The similarities are self-evident.





Cost Impact: Will not increase the cost of construction
This change simply identifies another type of vented cladding.

**Report of Committee Action
Hearings**

Committee Action:

Approved as Submitted

Committee Reason: The committee approved this proposal based on the proponents published reason statement. The added material has similar venting characteristics as the other materials in Item 1.

Assembly Action:

None

Final Action Results

RB276-16

AS

Code Change No: **RB280-16**

Original Proposal

Section: R703.1.1

Proponent: Edward Keith, representing APA- The Engineered Wood Association (ed.keith@apawood.org)

Revise as follows:

R703.1.1 Water resistance. The exterior wall envelope shall be designed and constructed in a manner that prevents the accumulation of water within the wall assembly by providing a water-resistant barrier behind the exterior ~~veneer cladding~~ as required by Section R703.2 and a means of draining to the exterior water that enters the assembly. ~~Protection against condensation in penetrates the exterior wall assembly shall be provided in accordance with Section R702.7 of this code cladding.~~

Exceptions:

1. A weather-resistant exterior wall envelope shall not be required over concrete or masonry walls designed in accordance with Chapter 6 and flashed in accordance with Section R703.4 or R703.8.
2. Compliance with the requirements for a means of drainage, and the requirements of Sections R703.2 and R703.4, shall not be required for an exterior wall envelope that has been demonstrated to resist wind-driven rain through testing of the exterior wall envelope, including joints, penetrations and intersections with dissimilar materials, in accordance with ASTM E 331 under the following conditions:
 - 2.1. Exterior wall envelope test assemblies shall include at least one opening, one control joint, one wall/eave interface and one wall sill. All tested openings and penetrations shall be representative of the intended end-use configuration.
 - 2.2. Exterior wall envelope test assemblies shall be at least 4 feet by 8 feet (1219 mm by 2438 mm) in size.
 - 2.3. Exterior wall assemblies shall be tested at a minimum differential pressure of 6.24 pounds per square foot (299 Pa).
 - 2.4. Exterior wall envelope assemblies shall be subjected to the minimum test exposure for a minimum of 2 hours. The exterior wall envelope design shall be considered to resist wind-driven rain where the results of testing indicate that water did not penetrate control joints in the exterior wall envelope, joints at the perimeter of openings penetration or intersections of terminations with dissimilar materials.

Reason: The term "veneer" can be misleading as its original meaning refers to a thin decorative covering. Certain siding products can exhibit structural and thermal properties which goes beyond being decorative. "Cladding," on the other hand, is a more general term that can be applied to a wider range of products. The term "enters the assembly" can be misleading as it may suggest water penetrating into the structural assembly (i.e. stud cavity), which can no longer be drained to the exterior. Draining of exterior water should only apply to the water that has penetrated or passed through the first line of defense, the cladding. The last sentence does not belong in this section of the code and is addressed in the APA code change proposal on R702.7.

Cost Impact: Will not increase the cost of construction
This code change will not increase the cost of construction as it clarifies the intent of the original code provisions.

Public Hearing Results

Committee Action:

Approved as Submitted

Committee Reason: The committee approved this proposal based on the proponents published reason statement. The change to the word cladding improves the wording of the code.

Assembly Action:

None

Final Action Results

RB280-16

AS

Code Change No: **RB323-16**

Original Proposal

Section: R806.1, R806.3

Proponent: Mike Fischer, Kellen, representing Asphalt Roofing Manufacturers Association (mfischer@kellencompany.com)

Revise as follows:

R806.1 Ventilation required. Enclosed attics and enclosed rafter spaces formed where ceilings are applied directly to the underside of roof rafters shall have cross ventilation for each separate space by ventilating openings protected against the entrance of rain or snow. Ventilation openings shall have a least dimension of $\frac{1}{16}$ inch (1.6 mm) minimum and $\frac{1}{4}$ inch (6.4 mm) maximum. Ventilation openings having a least dimension larger than $\frac{1}{4}$ inch (6.4 mm) shall be provided with corrosion-resistant wire cloth screening, hardware cloth, perforated vinyl or similar material with openings having a least dimension of $\frac{1}{16}$ inch (1.6 mm) minimum and $\frac{1}{4}$ inch (6.4 mm) maximum. Openings in roof framing members shall conform to the requirements of Section R802.7. Required ventilation openings shall open directly to the outside air and shall be protected to prevent the entry of birds, rodents, snakes and other similar creatures.

R806.3 Vent and insulation clearance. Where eave or cornice vents are installed, blocking, bridging and insulation shall not block the free flow of air. Not less than a 1-inch (25 mm) space shall be provided between the insulation and the roof sheathing and at the location of the vent.

Reason: This proposal is editorial and will bring the IRC requirements into alignment with the IBC ventilation requirements.

Cost Impact: Will not increase the cost of construction
The proposal is editorial and adds no additional requirements.

Report of Committee Action Hearings

Committee Action:

Approved as Submitted

Committee Reason: The committee approved this proposal based on the proponents published reason statement. This adds requirements to prevent the entry of vermin.

Assembly Action:

None

Final Action Results

RB323-16

AS

Code Change No: **RB324-16**

Original Proposal

Section: R806.2

Proponent: Mike Fischer, Kellen, representing Asphalt Roofing Manufacturers Association (mfischer@kellencompany.com)

Revise as follows:

R806.2 Minimum vent area. The minimum net free ventilating area shall be $1/150$ of the area of the vented space.

Exception: The minimum net free ventilation area shall be $1/300$ of the vented space provided ~~one or more~~ both of the following conditions are met:

1. In Climate Zones 6, 7 and 8, a Class I or II vapor retarder is installed on the warm-in-winter side of the ceiling.
2. Not less than 40 percent and not more than 50 percent of the required ventilating area is provided by ventilators located in the upper portion of the attic or rafter space. Upper ventilators shall be located not more than 3 feet (914 mm) below the ridge or highest point of the space, measured vertically, with the balance of the required ventilation provided by eave or cornice vents. Where the location of wall or roof framing members conflicts with the installation of upper ventilators, installation more than 3 feet (914 mm) below the ridge or highest point of the space shall be permitted.

Reason: The proposal is a clarification to align the IRC with the IBC requirements for the reduction in ventilation area.

Cost Impact: Will increase the cost of construction

The proposal may increase the cost of construction due to additional requirements to reduce the net free vent area.

Report of Committee Action Hearings

Committee Action:

Approved as Submitted

Committee Reason: The committee approved this proposal based on the proponents published reason statement.

Assembly Action:

None

Final Action Results

RB324-16

AS

Code Change No: **RB325-16**

Original Proposal

Section: R806.2

Proponent: Kevin McOsker, representing Southern Nevada Chapter of ICC (ktm@ClarkCountyNV.gov)

Revise as follows:

R806.2 Minimum vent area. The minimum net free ventilating area shall be $\frac{1}{150}$ of the area of the vented space.

Exception: The minimum net free ventilation area shall be $\frac{1}{300}$ of the vented space provided one or more of the following conditions are met:

1. In Climate Zones 6, 7 and 8, a Class I or II vapor retarder is installed on the warm-in-winter side of the ceiling.
2. Not less than 40 percent and not more than 50 percent of the required ventilating area is provided by ventilators located in the upper portion of the attic or rafter space. Upper ventilators shall be located not more than 3 feet (914 mm) below the ridge or highest point of the space, measured vertically, with the balance of the required ventilation provided ~~by eave or cornice vents~~ shall be located in the bottom 1/3 of the attic space. Where the location of wall or roof framing members conflicts with the installation of upper ventilators, installation more than 3 feet (914 mm) below the ridge or highest point of the space shall be permitted.

Reason: Due to property line separation requirements, restricting the lower vents to the eave or cornice, may not be achievable. The intent of this change does not restrict the use of eave or cornice vents when they are located in the bottom 1/3 of the attic space. Installing ventilation at the bottom 1/3 of the attic space achieves similar cross ventilation effect as eave and cornice vents. Allowing the lower ventilators to be placed on the roof, allows the designer flexibility, without creating a conflict with Table R302.1(1) or R302.1(2), where opening may not be allowed.

Cost Impact: Will not increase the cost of construction
Design flexibility will not increase costs.

Report of Committee Action Hearings

Committee Action:

Approved as Submitted

Committee Reason: The committee approved this proposal based on the proponents published reason statement. This provides flexibility for the placement of the ventilation.

Assembly Action:

None

Final Action Results

RB325-16

AS

Code Change No: **RB326-16**

Original Proposal

Section: R806.5

Proponent: Craig Conner, representing self (craig.conner@mac.com)

Revise as follows:

R806.5 Unvented attic and unvented enclosed rafter assemblies. Unvented *attics* and unvented enclosed roof framing assemblies created by ceilings that are applied directly to the underside of the roof framing members and structural roof sheathing applied directly to the top of the roof framing members/rafters, shall be permitted where all the following conditions are met:

1. The unvented *attic* space is completely within the *building thermal envelope*.
2. No interior Class I vapor retarders are installed on the ceiling side (*attic* floor) of the unvented *attic* assembly or on the ceiling side of the unvented enclosed roof framing assembly.
3. Where wood shingles or shakes are used, a minimum 1/4-inch (6.4 mm) vented airspace separates the shingles or shakes and the roofing underlayment above the structural sheathing.
4. In Climate Zones 5, 6, 7 and 8, any *air-impermeable insulation* shall be a Class II vapor retarder, or shall have a Class II vapor retarder coating or covering in direct contact with the underside of the insulation.
5. Insulation shall be located in accordance with the following:
 - 5.1. Item 5.1.1, 5.1.2, 5.1.3 or 5.1.4 shall be met, depending on the air permeability of the insulation directly under the structural roof sheathing.
 - 5.1.1. Where only *air-impermeable insulation* is provided, it shall be applied in direct contact with the underside of the structural roof sheathing.
 - 5.1.2. Where *air-permeable insulation* is ~~provided inside the building thermal envelope, it shall be installed in accordance with Section 5.1.~~ In addition to the *air-permeable insulation* installed directly below the structural sheathing, rigid board or sheet insulation shall be installed directly above the structural roof sheathing in accordance with the *R*-values in Table R806.5 for condensation control.
 - 5.1.3. Where both *air-impermeable* and *air-permeable insulation* are provided, the *air-impermeable insulation* shall be applied in direct contact with the underside of the structural roof sheathing in accordance with Item 5.1.1 and shall be in accordance with the *R*-values in Table R806.5 for condensation control. The *air-permeable insulation* shall be installed directly under the *air-impermeable insulation*.
 - 5.1.4. Alternatively, sufficient rigid board or sheet insulation shall be installed directly above the structural roof sheathing to maintain the monthly average temperature of the underside of the structural roof sheathing above 45°F (7°C). For calculation purposes, an interior air temperature of 68°F (20°C) is assumed and the exterior air temperature is assumed to be the monthly average outside air temperature of the three coldest months.
 - 5.2. Where preformed insulation board is used as the air-impermeable insulation layer, it shall be sealed at the perimeter of each individual sheet interior surface to form a continuous layer.

Reason: This is an editorial improvement, which makes the code clearer. There is no change in the requirements.

Cost Impact: Will not increase the cost of construction
This clarifies the code.

**Report of Committee Action
Hearings**

Committee Action:

Approved as Submitted

Committee Reason: The committee approved this proposal based on the proponents published reason statement.

Assembly Action:

None

Final Action Results

RB326-16

AS

Code Change No: **RB327-16**

Original Proposal

Section: R202 (New), R806.5

Proponent: Craig Conner, representing self (craig.conner@mac.com); Joseph Lstiburek, representing self (joe@buildingscience.com)

Add new definition as follows:

Vapor Diffusion Port. A passageway for conveying water vapor from an unvented attic to the outside atmosphere.

Revise as follows:

R806.5 Unvented attic and unvented enclosed rafter assemblies. Unvented *attics* and unvented enclosed roof framing assemblies created by ceilings that are applied directly to the underside of the roof framing members and structural roof sheathing applied directly to the top of the roof framing members/rafters, shall be permitted where all the following conditions are met:

1. The unvented *attic* space is completely within the *building thermal envelope*.
2. No interior Class I vapor retarders are installed on the ceiling side (*attic* floor) of the unvented *attic* assembly or on the ceiling side of the unvented enclosed roof framing assembly.
3. Where wood shingles or shakes are used, a minimum 1/4-inch (6.4 mm) vented airspace separates the shingles or shakes and the roofing underlayment above the structural sheathing.
4. In Climate Zones 5, 6, 7 and 8, any *air-impermeable insulation* shall be a Class II vapor retarder, or shall have a Class II vapor retarder coating or covering in direct contact with the underside of the insulation.
5. Insulation shall ~~be located in accordance with the following with~~ comply with either 5.1 or 5.2, and additionally 5.3:
 - 5.1. Item 5.1.1, 5.1.2, 5.1.3 or 5.1.4 shall be met, depending on the air permeability of the insulation directly under the structural roof sheathing.
 - 5.1.1. Where only *air-impermeable insulation* is provided, it shall be applied in direct contact with the underside of the structural roof sheathing.
 - 5.1.2. Where *air-permeable insulation* is provided inside the building thermal envelope, it shall be installed in accordance with Section 5.1. In addition to the *air-permeable insulation* installed directly below the structural sheathing, rigid board or sheet insulation shall be installed directly above the structural roof sheathing in accordance with the *R*-values in Table R806.5 for condensation control.
 - 5.1.3. Where both *air-impermeable* and *air-permeable insulation* are provided, the *air-impermeable insulation* shall be applied in direct contact with the underside of the structural roof sheathing in accordance with Item 5.1.1 and shall be in accordance with the *R*-values in Table R806.5 for condensation control. The *air-permeable insulation* shall be installed directly under the *air-impermeable insulation*.
 - 5.1.4. Alternatively, sufficient rigid board or sheet insulation shall be installed directly above the structural roof sheathing to maintain the monthly average temperature of the underside of the structural roof sheathing above 45°F (7°C). For calculation purposes, an interior air temperature of 68°F (20°C) is assumed and the exterior air temperature is assumed to be the monthly average outside air temperature of the three coldest months.

- 5.2. In climate zones 1, 2, and 3 when air-permeable insulation is installed in unvented attics it shall meet the following requirements: 1) An *approved vapor diffusion port* shall be installed not more than 12 inches (305mm) from the highest point of the roof, measured vertically from the highest point of the roof to the lower edge of the port. 2) The port area shall be $\geq 1:600$ of the ceiling area. Where there are multiple ports in the attic, the sum of the port areas shall be greater than or equal to the area requirement. 3) The vapor permeable membrane in the *vapor diffusion port* shall have a vapor permeance rating of ≥ 20 perms when tested in accordance with Procedure A of ASTM E96. 4) The *vapor diffusion port* shall serve as an *air barrier* between the attic and the exterior of the building. 5) The *vapor diffusion port* shall protect the attic against the entrance of rain and snow. 6) Framing members and blocking shall not block the free flow of water vapor to the port. Not less than a 2-inch (50 mm) space shall be provided between any blocking and the roof sheathing. Air-permeable insulation shall be permitted within that space. 7) The roof slope shall be $\geq 3:12$ (vertical/horizontal). 8) Where only air-permeable insulation is used, it shall be installed directly below the structural roof sheathing. 9) Air-impermeable insulation, if any, shall be directly above or below the structural roof sheathing and is not required to meet the R-value in in table 806.5. When directly below the structural roof sheathing, there shall be no space between the air-impermeable and air-permeable insulation. 10) The air shall be supplied at a flow rate ≥ 50 CFM (23.6 L/s) per 1000 ft² of ceiling. The air shall be supplied from ductwork providing supply air to the occupiable space when the conditioning system is operating. Alternatively, the air shall be supplied by a supply fan when the conditioning system is operating.
- 5.3. Where preformed insulation board is used as the air-impermeable insulation layer, it shall be sealed at the perimeter of each individual sheet interior surface to form a continuous layer.

Reason: Unvented attic assemblies have a record of success. Unvented attic assemblies are most commonly constructed with spray polyurethane foam applied directly to the underside of the roof deck. This is a historically successful method of construction with over 20 years of experience. Another approach to unvented attic assemblies is to insulate over the top of the roof deck with rigid insulation boards.

The proposed code change allows the use of lower cost alternatives. Specifically, the proposed code change allows the use of fiberglass batts, blown cellulose and blown fiberglass to construct unvented attic assemblies. The approach is limited to Climate Zones 1, 2 and 3 based on research and historic experience over the past decade.

The proposed code change adds a vapor diffusion port/vent. The port acts as a moisture control measure, allowing moisture in the attic to be removed by vapor diffusion rather than by air change. This allows the attic assembly to remain airtight while providing a path for vapor moisture via vapor diffusion. Airtight attics also benefit energy efficiency.

This allows alternatives to rigid board and spray polyurethane foam. Alternatives provides more material choices for designers, builders and consumers who have issues with the greenhouse gas potential of blowing agents, impacts of fire retardants and off-gassing of some insulation products. Or just want to try a less expensive option.

Adding new unvented attic options to the existing options provides additional benefits. In high wildfire regions the elimination of eave vents and air sealing the upper attic vents at ridges reduces the entry of embers. In hurricane zones the elimination of roof vents reduces the entry of rainwater during hurricane events.

The research work supporting this code change is an outgrowth of the original research work supporting unvented attic assemblies started in 1995 under the Department of Energy's Building America Program. The same technical team and the same technical rigor that supported the original code changes for unvented attics in the early 2000's are behind this proposed code change.

The technical rationale and research behind this code change can be found at [Venting Vapor](#). For a history of conditioned attics, see [Cool Hand Luke Meets Attics](#). Here is the [technical data](#) and [more technical data](#) (link to research report at lower right of page on web site).

Cost Impact: Will not increase the cost of construction
This will provide options.

Report of Committee Action Hearings

Committee Action:

Approved as Submitted

Committee Reason: The committee approved this proposal based on the proponents published reason statement and there was no testimony from opponents that the science will not work. This adds a good option for unvented attics.

Assembly Action:

None

Final Action Results

RB327-16

AS

Code Change No: **RB339-16**

Original Proposal

Section: R902.4

Proponent: Jonathan Roberts (jonathan.roberts@ul.com)

Revise as follows:

R902.4 Rooftop-mounted photovoltaic ~~panels and modules~~ panel systems. Rooftop-mounted photovoltaic ~~panels and modules~~ panel systems installed on or above the roof covering shall be tested, listed and identified with a fire classification in accordance with UL 1703 and UL 2703. Class A, B or C photovoltaic panels and modules shall be installed in jurisdictions designated by law as requiring their use or where the edge of the roof is less than 3 feet (914 mm) from a lot line.

Reference standards type: This reference standard is new to the ICC Code Books
Add new standard(s) as follows:

UL 2703-14, Mounting Systems, Mounting Devices, Clamping/Retention Devices, and Ground Lugs for Use with Flat-Plate Photovoltaic Modules and Panels

Reason: This correlates with the action taken in group A, S2-15 at the public comment hearing. This proposal aligns the IRC requirements with IBC Section 1505.9 for fire classification of photovoltaic panel systems. The position of the photovoltaic panels, as well as the slope of the roof, are critical factors in determining the fire classification of a photovoltaic panel system. The position of the photovoltaic panels is established by the racking system. Thus, the testing for photovoltaic panel systems are covered in both UL 1703 and UL 2703. The new UL 2703 standard, which is an ANSI consensus standard, provides the test method for testing multiple panels for each racking system

Cost Impact: Will not increase the cost of construction

This code change simply provides the appropriate method for testing photovoltaic panel systems for fire classification, as required by the ANSI standards. This method is already in use within the industry therefore there is no additional cost to construction.

Analysis: A review of the standard(s) proposed for inclusion in the code, UL 2703-14, with regard to the ICC criteria for referenced standards (Section 3.6 of CP#28) will be posted on the ICC website on or before April 1, 2016.

Report of Committee Action Hearings

Committee Action:

Approved as Modified

Modify as follows:

R902.4 Rooftop-mounted photovoltaic panel systems. Rooftop-mounted ~~photovoltaic panel systems~~ photovoltaic panel systems installed on or above the roof covering shall be tested, listed and identified with a fire classification in accordance with UL 1703 and UL 2703. Class A, B or C ~~photovoltaic panels and modules~~ photovoltaic panel systems shall be installed in jurisdictions designated by law as requiring their use or where the edge of the roof is less than 3 feet (914 mm) from a lot line.

Committee Reason: The committee approved this proposal based on the proponents published reason statement. This adds a new reference standard for testing of photovoltaic panel systems. The modification is an editorial correction for the term photovoltaic panel systems.

Assembly Action

None

Final Action Results

RB339-16

AM

Code Change No: **RB341-16**

Original Proposal

Section: R905.1.1

Proponent: T. Eric Stafford, PE, representing Institute for Business and Home Safety

Revise as follows:

R905.1.1 Underlayment. Underlayment for asphalt shingles, clay and concrete tile, metal roof shingles, mineral-surfaced roll roofing, slate and slate-type shingles, wood shingles, wood shakes and metal roof panels shall conform to the applicable standards listed in this chapter. Underlayment materials required to comply with ASTM D 226, D 1970, D 4869 and D 6757 shall bear a label indicating compliance to the standard designation and, if applicable, type classification indicated in Table R905.1.1(1). Underlayment shall be applied in accordance with Table R905.1.1(2). Underlayment shall be attached in accordance with Table R905.1.1(3).

Exceptions:

1. As an alternative, self-adhering polymer-modified bitumen underlayment complying with ASTM D 1970 installed in accordance with both the underlayment manufacturer's and roof covering manufacturer's instructions for the deck material, roof ventilation configuration and climate exposure for the roof covering to be installed, shall be permitted.
2. As an alternative, a minimum 4-inch-wide (102 mm) strip of self-adhering polymer-modified bitumen membrane complying with ASTM D 1970, installed in accordance with the manufacturer's instructions for the deck material, shall be applied over all joints in the roof decking. An approved underlayment for the applicable roof covering for maximum ultimate design wind speeds, V_{ult} , less than 140 miles per hour shall be applied over the entire roof over the 4-inch-wide (102 mm) membrane strips.
3. As an alternative, two layers of underlayment complying with ASTM D 226 Type II or ASTM D 4869 Type IV shall be permitted to be installed as follows: Apply a 19-inch strip of underlayment parallel with the eave. Starting at the eave, apply 36-inch-wide strips of underlayment felt, overlapping successive sheets 19 inches. The underlayment shall be attached with corrosion-resistant fasteners in a grid pattern of 12 inches between side laps with a 6-inch spacing at side and end laps. End laps shall be 4 inches and shall be offset by 6 feet (1829 mm). Underlayment shall be attached using metal or plastic cap nails with a nominal cap diameter of not less than 1 inch. Metal caps shall have a thickness of not less than 32-gage sheet metal. Power-driven metal caps shall have a minimum thickness of 0.010 inch. Minimum thickness of the outside edge of plastic caps shall be 0.035 inch. The cap nail shank shall be not less than 0.083 inch for ring shank cap nails and 0.091 inch for smooth shank cap nails. Cap nail shank shall have a length sufficient to penetrate through the roof sheathing or not less than 3/4 inch into the roof sheathing.

Reason: This proposal simply adds an additional method for preventing water penetration when the primary roof covering is lost due to high winds. Water penetration has been well documented from post-hurricane damage assessments where hurricane winds were strong enough to blow off the primary roof covering, but not strong enough to blow off roof sheathing. In such instances, significant property damage and extended occupant displacement routinely occur due to water intrusion. Such damage is common as asphalt shingles age and is particularly common in inland areas, where hurricane-strength winds occur, but building codes and standards are not as stringent as in coastal jurisdictions.

While the enhanced underlayment provisions are addressed in Tables R905.1.1(1), R905.1.1(2), and R905.1.1(3), the protection afforded by the current exceptions to Section R905.1.1 are in a bit of a different category. When the self-adhering polymer-modified bitumen underlayment as described in Exceptions 1 and 2 is used, the condition it creates is referred to as a "sealed roof deck" in that it prevents water from entering the building through gaps in the roof sheathing. They are also a component of the IBHS Fortified program for creating a sealed roof deck. The Fortified program is a set of engineering and building

standards designed to help strengthen new and existing homes through system-specific building upgrades to minimum building code requirements that will reduce damage from specific natural hazards. Recent tests conducted at the IBHS Research Facility have found the system proposed as new Exception 3, to perform similar to the self-adhering polymer-modified bitumen underlayment. As a result, this system of underlayment application and attachment is now recognized by the Fortified program for creating a sealed roof deck.

While this system is currently required in the code for roof slopes between 2:12 and 4:12 by Tables R905.1.1(2), R905.1.1(2), and R905.1.1(3), it provides an enhanced level of water penetration protection for roof slopes above 4:12 as well. Incorporating this method in the code provides an option for reducing the risk of water penetration that is on par with the self-adhering polymer-modified bitumen underlayment and makes it easier for local jurisdictions to accept its use as an option in areas where incentives for a sealed roof deck are provided.

Cost Impact: Will not increase the cost of construction
The proposed criteria is optional.

Report of Committee Action Hearings

Committee Action:

Approved as Modified

Modify as follows:

R905.1.1 Underlayment. Underlayment for asphalt shingles, clay and concrete tile, metal roof shingles, mineral-surfaced roll roofing, slate and slate-type shingles, wood shingles, wood shakes and metal roof panels shall conform to the applicable standards listed in this chapter. Underlayment materials required to comply with ASTM D 226, D 1970, D 4869 and D 6757 shall bear a label indicating compliance to the standard designation and, if applicable, type classification indicated in Table R905.1.1(1). Underlayment shall be applied in accordance with Table R905.1.1(2). Underlayment shall be attached in accordance with Table R905.1.1(3).

Exceptions:

1. As an alternative, self-adhering polymer-modified bitumen underlayment complying with ASTM D 1970 installed in accordance with both the underlayment manufacturer's and roof covering manufacturer's instructions for the deck material, roof ventilation configuration and climate exposure for the roof covering to be installed, shall be permitted.
2. As an alternative, a minimum 4-inch-wide (102 mm) strip of self-adhering polymer-modified bitumen membrane complying with ASTM D 1970, installed in accordance with the manufacturer's instructions for the deck material, shall be applied over all joints in the roof decking. An approved underlayment for the applicable roof covering for maximum ultimate design wind speeds, V_{ult} , less than 140 miles per hour shall be applied over the entire roof over the 4-inch-wide (102 mm) membrane strips.
3. As an alternative, two layers of underlayment complying with ASTM D 226 Type II or ASTM D 4869 Type III or Type IV shall be permitted to be installed as follows: Apply a 19-inch strip of underlayment parallel with the eave. Starting at the eave, apply 36-inch-wide strips of underlayment felt, overlapping successive sheets 19 inches. The underlayment shall be attached with corrosion-resistant fasteners in a grid pattern of 12 inches between side laps with a 6-inch spacing at side and end laps. End laps shall be 4 inches and shall be offset by 6 feet (1829 mm). Underlayment shall be attached using metal or plastic cap nails with a nominal cap diameter of not less than 1 inch. Metal caps shall have a thickness of not less than 32-gage sheet metal. Power-driven metal caps shall have a minimum thickness of 0.010 inch. Minimum thickness of the outside edge of plastic caps shall be 0.035 inch. The cap nail shank shall be not less than 0.083 inch for ring shank cap nails and 0.091 inch for smooth shank cap nails. Cap nail shank shall have a length sufficient to penetrate through the roof sheathing or not less than 3/4 inch into the roof sheathing.

Committee Reason: This proposal adds another underlayment system that is an alternative to the self-adhering underlayment. The modification adds another acceptable type of ASTM D4869 that provides another option.

Assembly Action

None

Final Action Results

RB341-16

AM

Code Change No: **RB343-16**

Original Proposal

Section: R905.1.1, R905.16.3, R905.16.4, R905.16.4.1, R905.16.4.2

Proponent: T. Eric Stafford, PE, representing Institute for Business and Home Safety

Revise as follows:

**TABLE R905.1.1 (1)
UNDERLAYMENT TYPES**

ROOF COVERING	SECTION	MAXIMUM ULTIMATE DESIGN WIND SPEED, V_{ult}	MAXIMUM ULTIMATE DESIGN WIND SPEED, $V_{ult} \geq 140$ MPH
Asphalt shingles	R905.2	ASTM D 226 Type I ASTM D 4869 Type I, II, III or IV ASTM D 6757	ASTM D 226 Type II ASTM D 4869 Type IV ASTM D 6757
Clay and concrete tile	R905.3	ASTM D 226 Type II ASTM D 2626 Type I ASTM D 6380 Class M mineral-surfaced roll roofing	ASTM D 226 Type II ASTM D 2626 Type I ASTM D 6380 Class M mineral-surfaced roll roofing
Metal roof shingles	R905.4	ASTM D 226 Type I or II ASTM D 4869 Type I, II, III or IV	ASTM D 226 Type II ASTM D 4869 Type IV
Mineral-surfaced roll roofing	R905.5	ASTM D 226 Type I or II ASTM D 4869 Type I, II, III or IV	ASTM D 226 Type II ASTM D 4869 Type IV
Slate and slate-type shingles	R905.6	ASTM D 226 Type I ASTM D 4869 Type I, II, III or IV	ASTM D 226 Type II ASTM D 4869 Type IV
Wood shingles	R905.7	ASTM D 226 Type I or II ASTM D 4869 Type I, II, III or IV	ASTM D 226 Type II ASTM D 4869 Type IV
Wood shakes	R905.8	ASTM D 226 Type I or II ASTM D 4869 Type I, II, III or IV	ASTM D 226 Type II ASTM D 4869 Type IV
Metal panels	R905.10	Manufacturer's instructions	ASTM D 226 Type II ASTM D 4869 Type IV
Photovoltaic shingles	R905.16	ASTM D 4869 Type I, II, III or IV ASTM D 6757	ASTM D 4869 Type IV ASTM D 6757

**TABLE R905.1.1 (2)
UNDERLAYMENT APPLICATION**

ROOF COVERING	SECTION	MAXIMUM ULTIMATE DESIGN WIND SPEED, V_{ult}	MAXIMUM ULTIMATE DESIGN WIND SPEED, $V_{ult} \geq 140$ MPH
Asphalt shingles	R905.2	For roof slopes from two units vertical in 12 units horizontal (2:12), up to four units vertical in 12 units horizontal (4:12), underlayment shall be two layers applied in the following manner: apply a 19-inch strip of underlayment felt parallel to and starting at the eaves. Starting at the eave, apply 36-inch-wide sheets of underlayment, overlapping successive sheets 19 inches. Distortions in the underlayment shall	Same as Maximum Ultimate Design Wind Speed, V_{ult}

ROOF COVERING	SECTION	MAXIMUM ULTIMATE DESIGN WIND SPEED, V_{ult}	MAXIMUM ULTIMATE DESIGN WIND SPEED, $V_{ult} \geq 140$ MPH
		<p>not interfere with the ability of the shingles to seal. <u>End laps shall be 4 inches and shall be offset by 6 feet.</u> For roof slopes of four units vertical in 12 units horizontal (4:12) or greater, underlayment shall be one layer applied in the following manner: underlayment shall be applied shingle fashion, parallel to and starting from the eave and lapped 2 inches, Distortions in the underlayment shall not interfere with the ability of the shingles to seal. End laps shall be 4 inches and shall be offset by 6 feet.</p>	
Clay and concrete tile	R905.3	<p>For roof slopes from two and one-half units vertical in 12 units horizontal ($2\frac{1}{2}$:12), up to four units vertical in 12 units horizontal (4:12), underlayment shall be a minimum of two layers applied as follows: starting at the eave, apply a 19-inch strip of underlayment parallel with the eave. Starting at the eave, apply 36-inch-wide strips of underlayment felt, overlapping successive sheets 19 inches. <u>End laps shall be 4 inches and shall be offset by 6 feet.</u> For roof slopes of four units vertical in 12 units horizontal (4:12) or greater, underlayment shall be a minimum of one layer of underlayment felt applied shingle fashion, parallel to and starting from the eaves and lapped 2 inches. End laps shall be 4 inches and shall be offset by 6 feet.</p>	Same as Maximum Ultimate Design Wind Speed, V_{ult}
Photovoltaic Shingles	R905.16	<p><u>For roof slopes from two units vertical in 12 units horizontal (2:12), up to four units vertical in 12 units horizontal (4:12), underlayment shall be two layers applied in the following manner: apply a 19-inch strip of underlayment felt parallel to and starting at the eaves. Starting at the eave, apply 36-inch-wide sheets of underlayment, overlapping successive sheets 19 inches. Distortions in the underlayment shall not interfere with the ability of the shingles to seal. End laps shall be 4 inches and shall be offset by 6 feet.</u> For roof slopes of four units vertical in 12 units horizontal (4:12) or greater, underlayment shall be one layer applied in the following manner: underlayment shall be applied shingle fashion, parallel to and starting from the eave and lapped 2 inches, Distortions in the underlayment shall not interfere with the ability of the</p>	<p><u>Same as Maximum Ultimate Design Wind Speed, $V_{ult} < 140$ mph except all laps shall be not less than 4 inches</u></p>

ROOF COVERING	SECTION	MAXIMUM ULTIMATE DESIGN WIND SPEED, V_{ult}	MAXIMUM ULTIMATE DESIGN WIND SPEED, $V_{ult} \geq 140$ MPH
		shingles to seal. End laps shall be 4 inches and shall be offset by 6 feet.	
Metal roof shingles	R905.4	Apply in accordance with the manufacturer's installation instructions.	For roof slopes from two units vertical in 12 units horizontal (2:12), up to four units vertical in 12 units horizontal (4:12), underlayment shall be two layers applied in the following manner: apply a 19-inch strip of underlayment felt parallel to and starting at the eaves. Starting at the eave, apply 36-inch-wide sheets of underlayment, overlapping successive sheets 19 inches, and fastened sufficiently to hold in place. End laps shall be 4 inches and shall be offset by 6 feet. For roof slopes of four units vertical in 12 units horizontal (4:12) or greater, underlayment shall be one layer applied in the following manner: underlayment shall be applied shingle fashion, parallel to and starting from the eave and lapped 4 inches. End laps shall be 4 inches and shall be offset by 6 feet.
Mineral-surfaced roll roofing	R905.5		
Slate and slate-type shingles	R905.6		
Wood shingles	R905.7		
Wood shakes	R905.8		
Metal panels	R905.10		

**TABLE R905.1.1 (3)
UNDERLAYMENT ATTACHMENT**

ROOF COVERING	SECTION	MAXIMUM ULTIMATE DESIGN WIND SPEED, V_{ult}	MAXIMUM ULTIMATE DESIGN WIND SPEED, $V_{ult} \geq 140$ MPH
Asphalt shingles	R905.2	Fastened sufficiently to hold in place	The underlayment shall be attached with corrosion-resistant fasteners in a grid pattern of 12 inches between side laps with a 6-inch spacing at the side and end laps. Underlayment shall be attached using metal or plastic cap nails or cap staples with a nominal cap diameter of not less than 1 inch. Metal caps shall have a thickness of not less than 32-gage sheet metal. Power-driven metal caps shall have a minimum thickness of 0.010 inch. Minimum thickness of the outside edge of plastic caps shall be 0.035 inch. The cap nail shank shall be not less than 0.083 inch for ring shank cap nails and 0.091 inch for smooth shank cap nails. Staples shall be not less than 21 gage. Cap nail shank and cap staple legs shall have a length sufficient to penetrate through the roof sheathing or not less than $\frac{3}{4}$ inch into the roof sheathing.
Clay and concrete tile	R905.3		
Photovoltaic shingles	R905.16		
Metal roof shingles	R905.4	Manufacturer's installation	The underlayment shall be

ROOF COVERING	SECTION	MAXIMUM ULTIMATE DESIGN WIND SPEED, V_{ult}	MAXIMUM ULTIMATE DESIGN WIND SPEED, $V_{ult} \geq 140$ MPH
Mineral-surfaced roll roofing	R905.5	instructions.	attached with corrosion-resistant fasteners in a grid pattern of 12 inches between side laps with a 6-inch spacing at the side and end laps. Underlayment shall be attached using metal or plastic cap nails or cap staples with a nominal cap diameter of not less than 1 inch. Metal caps shall have a thickness of at least 32-gage sheet metal. Power-driven metal caps shall have a minimum thickness of 0.010 inch. Minimum thickness of the outside edge of plastic caps shall be 0.035 inch. The cap nail shank shall be not less than 0.083 inch for ring shank cap nails and 0.091 inch for smooth shank cap nails. Staples shall be not less than 21 gage. Cap nail shank and cap staple legs shall have a length sufficient to penetrate through the roof sheathing or not less than $3/4$ inch into the roof sheathing.
Slate and slate-type shingles	R905.6		
Wood shingles	R905.7		
Wood shakes	R905.8		
Metal panels	R905.10		

For SI: 1 inch = 25.4 mm.

Revise as follows:

R905.16.3 Underlayment. ~~Unless otherwise noted, required underlayment~~
Underlayment shall conform to ASTM D 4869 or ASTM D6757, ~~comply with Section R905.1.1~~

R905.16.4.1 R905.16.3.1 Ice barrier. ~~In areas where there has been a history of~~
~~When required, ice forming along the eaves causing a backup of water, as designated in Table~~
R301.2(1), an ice barrier that consists of not less than two layers of underlayment cemented together or
of a self-adhering polymer modified bitumen sheet ~~barriers~~ shall be used in lieu of normal underlayment
and extend from the lowest edges of all roof surfaces to a point not less than 24 inches (610 mm) inside
the exterior wall line of the building ~~comply with Section R905.1.2.~~

Exception: ~~Detached accessory structures that contain no conditioned floor area.~~

Delete without substitution:

R905.16.4 Underlayment application. ~~Underlayment shall be applied shingle fashion, parallel to and~~
~~starting from the eave, lapped 2 inches (51 mm) and fastened sufficiently to hold in place.~~

R905.16.4.2 Underlayment and high winds. ~~Underlayment applied in areas subject to high winds~~
~~[above 140 mph (63 m/s), in accordance with Figure R301.2(4)A] shall be applied with corrosion-resistant~~
~~fasteners in accordance with the manufacturer's installation instructions. Fasteners are to be applied~~
~~along the overlap not farther apart than 36 inches (914 mm) on center.~~

~~Underlayment installed where the ultimate design wind speed equals or exceeds 150 mph (67 m/s)~~
~~shall comply with ASTM D 4869 Type IV, or ASTM D 6757. The underlayment shall be attached in a grid~~
~~pattern of 12 inches (305 mm) between side laps with a 6-inch (152 mm) spacing at the side laps.~~
~~Underlayment shall be applied as required for asphalt shingles in accordance with Table R905.1.1(2).~~
~~Underlayment shall be attached using metal or plastic cap nails with a head diameter of not less than 1~~
~~inch (25 mm) with a thickness of not less than 32-gage sheet metal. The cap-nail shank shall be not less~~

than 12 gage (0.105 inches) with a length to penetrate through the roof sheathing or not less than 3/4 inch (19 mm) into the roof sheathing.

Exception: As an alternative, adhered underlayment complying with ASTM D 1970 shall be permitted.

Reason: This proposal is primarily a clarification regarding the lapping requirements for underlayment and brings the underlayment requirements for PV shingles in line with other roof covering types.

For the two-layer underlayment application on low-sloped roofs, ends of the underlayment should be lapped 4 inches and offset 6 feet as required for the single layer application. The language "fastened to sufficiently hold in place" should be deleted from the underlayment application table (Table R905.1.1(2)) because underlayment attachment is covered in Table R905.1.1(3) and contains specific fastening requirements for wind speeds greater than or equal to 140 mph. Also, Table R905.1.1(3) has been revised to clarify that fastener spacing is the same for side and end laps.

Underlayment requirements for PV shingles have been relocated to Section R905.1.1 with the underlayment requirements for other roof coverings. The underlayment types, fastening requirements and wind speed triggers have been revised for consistent with the other roof covering types as required in the 2015 IRC.

Cost Impact: Will increase the cost of construction

Will result in a cost increase for PV shingles in some areas. The wind speed trigger for the enhanced underlayment provisions has been slightly lowered resulting in it applying to more areas where PV shingles are installed. Underlayment provisions for PV shingles will be aligned with other roof covering types.

Report of Committee Action Hearings

Committee Action:

Approved as Modified

Modify as follows:

**TABLE R905.1.1 (1)
UNDERLAYMENT TYPES**

ROOF COVERING	SECTION	MAXIMUM ULTIMATE DESIGN WIND SPEED, V_{ult}	MAXIMUM ULTIMATE DESIGN WIND SPEED, $V_{ult} \geq 140$ MPH
Asphalt shingles	R905.2	ASTM D 226 Type I ASTM D 4869 Type I, II, III or IV ASTM D 6757	ASTM D 226 Type II ASTM D 4869 <u>Type III or Type IV</u> ASTM D 6757
Clay and concrete tile	R905.3	ASTM D 226 Type II ASTM D 2626 Type I ASTM D 6380 Class M mineral-surfaced roll roofing	ASTM D 226 Type II ASTM D 2626 Type I ASTM D 6380 Class M mineral-surfaced roll roofing
Metal roof shingles	R905.4	ASTM D 226 Type I or II ASTM D 4869 Type I, II, III or IV	ASTM D 226 Type II ASTM D 4869 <u>Type III or Type IV</u>
Mineral-surfaced roll roofing	R905.5	ASTM D 226 Type I or II ASTM D 4869 Type I, II, III or IV	ASTM D 226 Type II ASTM D 4869 <u>Type III or Type IV</u>
Slate and slate-type shingles	R905.6	ASTM D 226 Type I ASTM D 4869 Type I, II, III or IV	ASTM D 226 Type II ASTM D 4869 <u>Type III or Type IV</u>
Wood shingles	R905.7	ASTM D 226 Type I or II ASTM D 4869 Type I, II, III or IV	ASTM D 226 Type II ASTM D 4869 <u>Type III or Type IV</u>
Wood shakes	R905.8	ASTM D 226 Type I or II ASTM D 4869 Type I, II, III or IV	ASTM D 226 Type II ASTM D 4869 <u>Type III or Type IV</u>
Metal panels	R905.10	Manufacturer's instructions	ASTM D 226 Type II ASTM D 4869 <u>Type III or Type IV</u>
Photovoltaic shingles	R905.16	ASTM D 4869 Type I, II, III or IV	ASTM D 4869 <u>Type III or Type IV</u>

		ASTM D 6757	ASTM D 6757
--	--	-------------	-------------

Committee Reason: The committee approved this proposal based on the proponents published reason statement. This proposal clarifies the lapping requirements for the underlayment. The modification adds another acceptable type of ASTM D4869 that provides another option.

Assembly Action

None

Final Action Results

RB343-16

AM

Code Change No: **RB345-16**

Original Proposal

Section(s): R905.15.3

Proponent: James Kirby, representing Roof Coating Manufacturers Association, representing Center for Environmental Innovation in Roofing (jkirby@kellenccompany.com)

Revise as follows:

R905.15.3 Application. Liquid-applied roofing shall be installed in accordance with this chapter and the manufacturer's approved installation instructions.

Reason: The proposal adds necessary language so that the application of roof coatings follows manufacturer's approved installation instructions.

Cost Impact: Will not increase the cost of construction
The proposal adds clarity and does not change code requirements.

Report of Committee Action Hearings

Committee Action:

Approved as Submitted

Committee Reason: The committee approved this proposal based on the proponents published reason statement and prior action on S29-16, Part II.

Assembly Action:

None

Public Comments

Public Comment 1:

James Kirby, representing Roof Coating Manufacturers Association (jameskirby47@icloud.com) requests Approve as Modified by this Public Comment.

Modify as follows:

R905.15.3 Application. Liquid-applied roofing shall be installed in accordance with this chapter and the manufacturer's approved installation instructions.

Commenter's Reason: The word "approved" was found to be controversial in subsequent proposals even though this proposal was Approved As Submitted. In order to be consistent in the 2018 codes, this public comment removes the word "approved" so there is no confusion by code officials regarding manufacturer's installation instructions for liquid-applied roofing in the IRC.

Final Action Results

RB345-16

AMPC1

Code Change No: **RB351-16**

Original Proposal

Section: R202 (New), R324.5.2 (New), R905.17 (New), R905.17.1 (New), R905.17.2 (New), R905.17.3 (New), R905.17.3.1 (New), R905.17.4 (New), R905.17.5 (New), R905.17.6 (New), R905.17.7 (New), UL (New)

Proponent: Lorraine Ross, Intech Consulting Inc, representing The Dow Chemical Company (Intech@tampabay.rr.com)

Add new definition as follows:

BUILDING-INTEGRATED PHOTOVOLTAIC ROOF PANEL (BIPV Roof Panel). *A photovoltaic panel that functions as a component of the building envelope.*

Add new text as follows:

R324.5.2 BIPV roof panels. *BIPV roof panels shall comply with Section R905.17.*

R905.17 BIPV roof panels applied directly to the roof deck. *The installation of BIPV roof panels shall comply with the provisions of this section, Section R324 and NFPA 70.*

R905.17.1 Deck requirements. *BIPV roof panels shall be applied to a solid or closely-fitted deck, except where the roof covering is specifically designed to be applied over spaced sheathing.*

R905.17.2 Deck slope. *BIPV roof panels shall be used only on roof slopes of two units vertical in 12 units horizontal (2:12) or greater.*

R905.17.3 Underlayment. *Unless otherwise noted, required underlayment shall conform to ASTM D4869 or ASTM D6757.*

R905.17.4 Underlayment application. *Underlayment shall be applied shingle fashion, parallel to and starting from the eave, lapped 2 inches (51 mm) and fastened sufficiently to hold in place.*

R905.17.4.1 Ice barrier. *In areas where there has been a history of ice forming along the eaves causing a backup of water, as designated in Table R301.2(1), an ice barrier that consists of not less than two layers of underlayment cemented together or of a self-adhering polymer modified bitumen sheet shall be used in lieu of normal underlayment and extend from the lowest edges of all roof surfaces to a point not less than 24 inches (610 mm) inside the exterior wall line of the building.*

Exception. *Detached accessory structures that contain no conditioned floor area.*

R905.17.4.2 Underlayment and high winds. *Underlayment applied in areas subject to high winds [above 140 mph (63 m/s), in accordance with Figure R301.2(4)A] shall be applied with corrosion-resistant fasteners in accordance with the manufacturer's installation instructions. Fasteners are to be applied along the overlap not further apart than 36 inches (914 mm) on center. Underlayment installed where the ultimate design wind speed equals or exceeds 150 mph (67 m/s) shall comply with ASTM D 4869 Type IV, or ASTM D 6757. The underlayment shall be attached in a grid pattern of 12 inches (305 mm) between side laps with a 6-inch (152 mm) spacing at the side laps. Underlayment shall be applied as required for asphalt shingles in accordance with Table R905.1.1(2). Underlayment shall be attached using metal or plastic cap nails with a head diameter of not less than 12 gage (0.105 inches) with a length to*

penetrate through the roof sheathing or not less than 3/4 inch (19 mm) into the roof sheathing.

Exception: As an alternative, adhered underlayment complying with ASTM D 1970 shall be permitted.

R905.17.5 Material standards. *BIPV roof panels shall be listed and labeled in accordance with UL 1703.*

R905.17.6 Attachment. *BIPV roof panels shall be attached in accordance with the manufacturer's installation instructions.*

R905.17.7 Wind resistance. *BIPV roof panels shall be tested in accordance with UL 1897. BIPV roof panel packaging shall bear a label to indicate compliance with UL 1897.*

Add new standard(s) follows:

UL 1897-12 Uplift Tests for Roof Covering System

Reason: This proposal adds new sections to the IRC to address Building-integrated (BIPV) roof panels. These products form part of the roof assembly and are subject to the same requirements as any other roof covering. As opposed to BIPV Shingles that are already regulated by the code, these BIPV panels are larger and the wind resistance is determined by UL 1897 Uplift Tests for Roof Covering System. The overall proposal contains four parts:

- A new definition for BIPV Roof Panel is added to Chapter 2
- A new section is added to R324 to point to the applicable technical requirements in Chapter 9 Roof Assemblies.
- A new section is added to Chapter 9 to detail the proper application of BIPV Roof Panels, including deck, underlayment, material standards and attachment requirements.
- A new standard, UL 1897 Uplift Tests for Roof Covering System is added to Chapter 44 of the IRC. This standard is already included in Chapter 34 of the IBC.

Cost Impact: Will not increase the cost of construction

This proposal does not increase the cost of construction. It adds another type of roof covering, enhancing builder choices.

Report of Committee Action Hearings

Committee Action:

Approved as Modified

Modify as follows:

R905.17.3 Underlayment. ~~Unless otherwise noted, required underlayment~~ Underlayment shall conform to ASTM D4869 or ASTM D6757 ~~comply with Section 905.1.1.~~

R905.17.3.1 Ice barrier. ~~When required, an ice barrier shall comply with Section R905.1.2.~~

R905.17.4.2 Underlayment and high winds. ~~Underlayment applied in areas subject to high winds [above 140 mph (63 m/s), in accordance with Figure R301.2(4)A] shall be applied with corrosion-resistant fasteners in accordance with the manufacturer's installation instructions. Fasteners are to be applied along the overlap not further apart than 36 inches (914 mm) on center. Underlayment installed where the ultimate design wind speed equals or exceeds 150 mph (67 m/s) shall comply with ASTM D 4869 Type IV, or ASTM D 6757. The underlayment shall be attached in a grid pattern of 12 inches (305 mm) between side laps with a 6-inch (152 mm) spacing at the side laps. Underlayment shall be applied as required for asphalt shingles in accordance with Table R905.1.1(2). Underlayment shall be attached using metal or plastic cap nails with a head diameter of not less than 12 gage (0.105 inches) with a length to penetrate through the roof sheathing or not less than 3/4 inch (19 mm) into the roof sheathing.~~

Exception: As an alternative, adhered underlayment complying with ASTM D 1970 shall be permitted.

R905.17.4 Underlayment application. ~~Underlayment shall be applied shingle fashion, parallel to and starting from the eave, lapped 2 inches (51 mm) and fastened sufficiently to hold in place.~~

Committee Reason: The committee approved this proposal based on the proponents published reason statement. This introduces new technology and provide another option for roof covering. The modification clarifies the underlayment requirements and adds reference to the proper code sections.

Assembly Action

None

Final Action Results

RB351-16

AM

Code Change No: **RB352-16**

Original Proposal

Section: R906.2

Proponent: Rick Roos, ROXUL Inc., representing ROXUL Inc. (richard.roos@roxul.com)

Revise as follows:

**TABLE R906.2
MATERIAL STANDARDS FOR ROOF INSULATION**

Cellular glass board	ASTM C 552
Mineral wool board	ASTM C 726
Composite boards	ASTM C 1289, Type III, IV, V or VI
Expanded polystyrene	ASTM C 578
Extruded polystyrene board	ASTM C 578
Perlite board	ASTM C 728
Polyisocyanurate board	ASTM C 1289, Type I or II
Wood fiberboard	ASTM C 208
Fiber-reinforced gypsum board	ASTM C 1278
Glass-faced gypsum board	ASTM C 1177

Reference standards type: This is an update to reference standard(s) already in the ICC Code Books
Add new standard(s) as follows:

ASTM C726-12 Standard Specification for Mineral Wool Roof Insulation Board

Reason: This proposal will add reference to the appropriate ASTM Standard specification for mineral wool roof insulation and make Table R906.2 consistent with IBC Table 1508.2. This will help to ensure that roofing systems designed using mineral wool roof insulation will perform as intended by the IRC. This standard has been referenced in the IBC since the 2012 edition.

ASTM C 726 specifies the composition and physical properties of mineral fiber insulation board used above structural roof decks as a base for built-up roofing and single ply membrane systems in building construction.

The use of thermal insulation materials covered by this Standard are regulated by the codes in the same manner as the other materials in the Table. This Standard covers testing and conformance to the following physical properties: compressive resistance, tensile strength, breaking load strength, water absorption, response to thermal and humid aging, linear dimensional change, thermal resistance, and dimensions.

Cost Impact: Will not increase the cost of construction

This proposal does not add to the cost of construction because it provides an additional, non-mandatory, alternative material that may or may not be used in these applications at the discretion of the user.

Report of Committee Action Hearings

Committee Action:

Approved as Submitted

Committee Reason: The committee approved this proposal based on the proponents published reason statement. The proposal adds a new option for roof insulation.

Assembly Action:

None

Final Action Results

RB352-16

AS

Code Change No: **RB354-16**

Original Proposal

Section: R907.2

Proponent: Jonathan Siu, City of Seattle Department of Construction & Inspections, representing Washington Association of Building Officials Technical Code Development Committee (jon.siu@seattle.gov)

Revise as follows:

~~R907.2~~ **R324.4.2 Wind resistance load.** Rooftop-mounted photovoltaic panel or modules systems and their supports shall be installed ~~designed~~ to resist the component and cladding loads specified in Table R301.2(2), adjusted for height and exposure in accordance with Table R301.2(3).

Reason: This proposal places the requirement for PV panel wind design in the same location as the other design load requirements.

Section R324.4 does not contain the wind load requirements for PV panels, although it references Section 907, which does. This proposal moves the text to a new section R324.4.2, so the requirement does not get missed. The phrase, "and their supports" was added to clarify that a complete load path must be provided to resist the wind loads. A separate proposal addresses roof loads.

Cost Impact: Will not increase the cost of construction

This proposal only moves a requirement and provides clarification and does not result in a change of design or construction.

Report of Committee Action Hearings

Committee Action:

Approved as Modified

Modify as follows:

R324.4.2 Wind load. Rooftop-mounted photovoltaic panel or modules systems and their supports shall be designed and installed to resist the component and cladding loads specified in Table R301.2(2), adjusted for height and exposure in accordance with Table R301.2(3).

Committee Reason: The committee approved this proposal based on the proponents published reason statement. The modification adds the clarification that it applies to the installation also.

Assembly Action

None

Final Action Results

RB354-16

AM

Code Change No: **RB359-16**

Original Proposal

Section: R1005.8 (New)

Proponent: Gregg Achman, Hearth & Home Technologies, representing Hearth & Home Technologies (achmang@hearthnhome.com)

Add new text as follows:

R1005.8 Insulation shield. Where factory-built chimneys pass through insulated assemblies, an insulation shield constructed of steel having a minimum thickness of 0.0187 inch (0.4712 mm) (No. 26 gage) shall be installed to provide clearance between the chimney and the insulation material. The clearance shall not be less than the clearance to combustibles specified by the chimney manufacturer's installation instructions. Where chimneys pass through attic space, the shield shall terminate not less than 2 inches (51 mm) above the insulation materials and shall be secured in place to prevent displacement. Insulation shields provided as part of a listed chimney system shall be installed in accordance with the manufacturer's installation instructions.

Reason: The codes currently require insulation shields for vents to ensure proper clearance to insulation so as not to cause a fire hazard, the code should also require insulation shields for factory-built chimneys as they also require clearance to insulation and it represents a fire hazard when one is not installed.

Cost Impact: Will not increase the cost of construction

Will not increase cost as the insulation shield should already be used, however, when the code does not call it out as required many times it gets overlooked.

Report of Committee Action Hearings

Committee Action:

Approved as Submitted

Committee Reason: This proposal ensures proper clearances on a situation that we need to have guidance on.

Assembly Action:

None

Final Action Results

RB359-16

AS

Code Change No: **RB360-16**

Original Proposal

Section: AE101.1, AE101.2 (New)

Proponent: Gregory Wilson, Federal Emergency Management Agency, representing Federal Emergency Management Agency (gregory.wilson2@fema.dhs.gov); Rebecca Quinn, RCQuinn Consulting, Inc. (rcquinn@earthlink.net)

Revise as follows:

AE101.1 General. These provisions shall be applicable only to a *manufactured home* used as a single *dwelling unit* installed on privately owned (nonrental) lots and shall apply to the following:

1. Construction, *alteration* and repair of any foundation system that is necessary to provide for the installation of a *manufactured home* unit.
2. Construction, installation, *addition*, *alteration*, repair or maintenance of the building service *equipment* that is necessary for connecting *manufactured homes* to water, fuel, or power supplies and sewage systems.
3. *Alterations*, *additions* or repairs to existing *manufactured homes*. The construction, *alteration*, moving, demolition, repair and use of accessory buildings and structures, and their building service *equipment*, shall comply with the requirements of the codes adopted by this *jurisdiction*.

These provisions shall not be applicable to the design and construction of *manufactured homes* and shall not be deemed to authorize either modifications or *additions* to *manufactured homes* where otherwise prohibited.

Exception: In addition to these provisions, new and replacement *manufactured homes* to be located in flood hazard areas as established in Table R301.2(1) of the *International Residential Code* shall meet the applicable requirements of Section R322 of the *International Residential Code*.

Add new text as follows:

AE101.2 Flood hazard areas. New and replacement *manufactured homes* to be installed in flood hazard areas as established in Table R301.2(1) of the *International Residential Code* shall also meet the applicable requirements of Section R322 of the *International Residential Code*.

Reason: This proposal is editorial. The text current in an exception should be a separate section. It is not good code writing to have an exception written to add to the basic requirement.

Cost Impact: Will not increase the cost of construction
Proposal only clarifies and puts the provision in proper format.

Report of Committee Action Hearings

Committee Action:

Approved as Submitted

Committee Reason: The proposal makes a useful editorial clarification.

Assembly Action:

None

Final Action Results

RB360-16

AS

Code Change No: **RB365-16**

Original Proposal

Section: 202, AR101, AR101.1, AR102, AR102.1, AR103, AR103.1, AR103.2, AR103.2.1, AR103.2.2, AR103.2.3, AR103.2.3 (New), AR103.2.4, AR103.2.4(1) (New), AR103.2.4(2) (New), AR103.2.4(3) (New), AR103.3, AR103.3.1, AR103.3.2, AR103.3.3, AR103.3.4, AR103.4, AR103.4.1, AR103.4.2, AR103.4.3, AR103.4.4, AR103.4.5, AR103.4.6, AR103.4.7, AR103.5, AR103.5.1, AR103.5.2, AR103.5.3, AR103.5.4, AR103.5.5, AR104, AR104.1, AR104.2 (New), AR105

Proponent: Lou Host-Jablonski, Design Coalition, Inc., representing Design Coalition, Inc. and StrawClay.org (lou@designcoalition.org); Scott Cherry, representing Lightfoot inc. (scott@lightfootinc.com); Douglas Piltingsrud, Design Coalition Institute, Inc., representing Sustainable Housing Research, LLC (dougiltingsrud@gmail.com); Richie Duncan, Kodama Zomes LLC, representing self (richie@kodamazomes.com); Paula Baker-Laporte, representing Econest Architecture Inc. (paula@econest.com); Martin Hammer, representing Martin Hammer, Architect (mfhammer@pacbell.net); Robert Laporte, representing EcoNest Company (robert@econest.com); Susan Thering, representing Design Coalition Institute Inc.; Jacob Racusin, New Frameworks Natural Design/Build, representing New Frameworks Natural Design/Build (jacob@newframeworks.com)

Revise as follows:

AR101.1 Scope. This appendix shall govern the use of light straw-clay as a nonbearing building material and wall infill system in Seismic Design Categories A and B. Use of light straw-clay in Seismic Design Categories C, D₀, D₁ and D₂ shall require an approved engineered design by a registered design professional in accordance with Section R301.1.3.

SECTION AR102 DEFINITIONS

AR102.1 General. The following words and terms shall, for the purposes of this appendix, have the meanings shown herein. Refer to Chapter 2 of the *International Residential Code* for general definitions.

CLAY. Inorganic soil with particle sizes of less than 0.00008 inch (0.002 mm) having the characteristics of high to very high dry strength and medium to high plasticity.

CLAY SLIP. A suspension of clay ~~soil~~ subsoil in water.

CLAY SOILSUBSOIL. ~~Inorganic soil~~ Subsoil sourced directly from the earth or refined, containing 50 percent or more clay by volume and free of organic matter.

INFILL. Light straw-clay that is placed between the structural and nonstructural members of a building.

LIGHT STRAW-CLAY. A mixture of straw and clay slip compacted and dried to form insulation and plaster substrate between or around structural and nonstructural members in a wall.

NONBEARING. Not bearing the weight of the building other than the weight of the light straw-clay itself and its finish.

STRAW. The dry stems of cereal grains after the seed heads have been removed.

VOID. Any space in a light straw-clay wall wider than 1/4 inch (6mm), greater than 2 inches (51 mm) in which a 2-inch horizontal length and greater than 2 inches (51 mm) sphere can be inserted in depth.

SECTION AR103 NONBEARING LIGHT STRAW-CLAY CONSTRUCTION

AR103.1 General. Light straw-clay shall be limited to infill between or around structural and nonstructural wall framing members.

AR103.2 Structure. The structure of buildings using light straw-clay shall be in accordance with the *International Residential Code* or shall be in accordance with an *approved* design by a registered *design professional*.

AR103.2.1 Number of stories. Use of light straw-clay infill shall be limited to buildings that are not more than one *story above grade plane*.

Exception: Buildings using light straw-clay infill that are greater than one *story above grade plane* shall be in accordance with an approved design by a registered *design professional*.

AR103.2.2 Bracing. ~~Wind bracing~~ Bracing for buildings with light straw-clay infill shall be in accordance with Section R602.10 and ~~shall use Method LIB.~~ Walls with light straw-clay infill shall use Method LIB and shall not be sheathed with solid sheathing. Walls without light straw-clay infill shall comply with any bracing method prescribed by this code.

AR103.2.3 Weight Requirements and properties of light straw-clay mixtures. ~~Light~~ The requirements and properties of light straw-clay mixtures shall be ~~deemed to have a design dead load of 40 pounds per cubic foot (640 kg per cubic meter) unless otherwise demonstrated to the building official~~ in accordance with Table AR103.2.3.

AR103.2.4 Reinforcement Stabilization of light straw-clay. Light straw-clay shall be ~~reinforced~~ stabilized as follows, or shall be in accordance with an approved design by a registered design professional:

1. ~~Vertical reinforcing shall be not less than nominal 2-inch by 6-inch (51 mm by 152 mm) wood members at not more than 32 inches (813 mm) on center where the vertical reinforcing is nonload bearing and at 24 inches (610 mm) on center where it is load bearing. The vertical reinforcing shall not exceed an unrestrained height of 10 feet (3048 mm) and shall be attached at top and bottom in accordance with Chapter 6 of the this code. In lieu of these requirements, vertical reinforcing shall be in accordance with an approved design by a registered design professional.~~
2. ~~Horizontal reinforcing shall be installed in the center of the wall at not more than 24 inches (610 mm) on center and shall be secured to vertical members. Horizontal reinforcing shall be of any of the following: 3/4-inch (19.1 mm) bamboo, 1/2-inch (12.7 mm) fiberglass rod, 1-inch (25 mm) wood dowel or nominal 1-inch by 2-inch (25 mm by 51 mm) wood.~~
3. Vertical stabilization shall be of structural or nonstructural wood framing in accordance with Figures AR103.2.4(1), AR103.2.4(2) or AR103.2.4(3). Such framing members shall not be prohibited to be both load-bearing and stabilization members where they meet the requirements of Section R602 and this section. Nonstructural stabilization members shall be not more than 32 inches (813mm) on center.
4. Horizontal stabilization shall be installed at not more than 24 inches (610 mm) on center and in accordance with Figures AR103.2.4(1), AR103.2.4(2) or AR103.2.4(3). Horizontal stabilization shall be of any of the following with the stated minimum dimensions: 3/4-inch (19.1 mm) bamboo, 1/2-inch (12.7 mm) fiberglass rod, 1-inch (25 mm) wood dowel or nominal 1-inch by 2-inch (25 mm by 51 mm) wood.

AR103.3 Materials. The materials used in light straw-clay construction shall be in accordance with Sections AR103.3.1 through AR103.3.4 ~~AR103.3.3~~.

AR103.3.1 Straw requirements. Straw shall be stems of wheat, rye, oats, rice or barley, and shall be free of visible decay, insects and ~~insects~~ green plant material.

AR103.3.2 Clay soil-subsoil requirements. Suitability of clay ~~soil~~ subsoil shall be determined in accordance with the ~~Figure 2 Ribbon Test or the Figure 3 Ball Test of the Appendix to ASTM E 2392/ E 2392M~~ Table AR103.2.3.

Delete without substitution:

~~**AR103.3.3 Clay slip.** Clay slip shall be of sufficient viscosity such that a finger dipped in the slip and withdrawn remains coated with an opaque coating.~~

Revise as follows:

~~**AR103.3.4 AR103.3.3 Light straw-clay mixture.** Light-A light straw-clay mixture shall contain not less than 65 percent and not more than 85 percent straw, by volume consist of ~~bale compacted loose~~ straw to clay soil. ~~Loose straw shall be mixed and coated with clay slip such that there is not more than 5 percent uncoated straw and shall be in accordance with Table AR103.2.3.~~~~

AR103.4 Wall construction. Light straw-clay wall construction shall be in accordance with the requirements of Sections AR103.4.1 through AR103.4.7.

AR103.4.1 Light straw-clay maximum thickness. ~~Light~~The maximum thickness of light straw-clay shall be not more than 12 inches (305 mm) thick, to allow adequate drying of the installed material in accordance with Table AR103.2.3.

AR103.4.2 Distance above grade. Light straw-clay and its exterior finish shall be not less than 8 inches (203 mm) above exterior finished *grade*.

AR103.4.3 Moisture barrier. An *approved* moisture barrier shall separate the bottom of light straw-clay walls from any masonry or concrete foundation or slab that directly supports the walls. Penetrations and joints in the barrier shall be sealed with an *approved* sealant.

AR103.4.4 Contact with wood members. Light straw-clay shall be permitted to be in contact with untreated wood members.

AR103.4.5 Contact with nonwood structural members. Nonwood structural members in contact with light straw-clay shall be resistant to corrosion or shall be coated to prevent corrosion with an *approved* coating.

AR103.4.6 Installation. Light straw-clay shall be installed in accordance with the following:

1. Formwork shall be sufficiently strong to resist bowing where the light straw-clay is compacted into the forms.
2. Light straw-clay shall be uniformly placed into forms and evenly tamped to achieve stable walls free of voids. Light straw-clay shall be placed in lifts of not more than 6 inches (152 mm) and shall be thoroughly tamped before additional material is added.
3. ~~Formwork~~ Temporary formwork shall be removed from walls within 24 hours after tamping, and walls shall remain exposed until moisture content is in accordance with Section AR103.5.1. Visible voids shall be ~~patched~~ filled with light straw-clay or other insulative material prior to plastering.

AR103.4.7 Openings in walls. Openings in walls shall be in accordance with the following:

1. Rough framing for doors and windows shall be fastened to structural members in accordance with the *International Residential Code*. Windows and doors shall be flashed in accordance with the *International Residential Code*.
2. An *approved* moisture barrier shall be installed at window sills in light straw-clay walls prior to installation of windows.

AR103.5 Wall finishes. The interior and exterior surfaces of light straw-clay walls shall be protected with a finish in accordance with Sections AR103.5.1 through AR103.5.5.

AR103.5.1 ~~Moisture content~~ Dimensional stability of light straw-clay prior to application of plaster finish. Light straw-clay walls-infill having a density of 30 pounds per cubic foot (480.6 kg/m³) or greater shall be dry to a moisture content of not more than 20 percent at a depth of 4 inches (102 mm), as measured from each side of the wall, ~~prior to~~. Light straw-clay infill having a density of less than 30 pounds per cubic foot (480.6 kg/m³) shall be sufficiently dry such that the application of finish on either side-overall shrinkage of the wall. Moisture content shall be measured with a moisture meter equipped with a probe that light straw-clay is designed for use with baled straw or hay dimensionally stable.

AR103.5.2 Plaster finish. Exterior plaster ~~finishes~~ shall be clay plaster ~~plasters~~ or lime plaster ~~plasters~~. Interior plaster ~~finishes~~ ~~plasters~~ shall be clay plaster ~~plasters~~, lime plaster ~~plasters~~ or gypsum plaster ~~plasters~~. Plasters shall be permitted to be applied directly to the surface of the light straw-clay walls without reinforcement, except that the juncture of dissimilar substrates shall be in accordance with Section AR103.5.4. Plasters shall have a thickness of not less than 1/2 inch (12.7 mm) and not more than 1 inch (25 mm) and shall be installed in not less than two coats. ~~Exterior Rain-exposed~~ clay plaster ~~plasters~~ shall be finished with a lime-based or silicate-mineral coating.

AR103.5.3 Separation of wood and plaster. Where wood framing occurs in light straw-clay walls, such wood surfaces shall be separated from exterior plaster with No.15 asphalt felt, Grade D paper or other approved material except where the wood is preservative treated or naturally durable.

Exception: Exterior clay plasters shall not be required to be separated from wood.

AR103.5.4 Bridging across dissimilar substrates. Bridging shall be installed across dissimilar substrates prior to the application of plaster. Acceptable bridging materials include: expanded metal lath, woven wire mesh, welded wire mesh, fiberglass mesh, reed matting or burlap. Bridging shall extend not less than 4 inches (102 mm), on both sides of the juncture.

AR103.5.5 Exterior siding-cladding. Exterior ~~wood, metal or composite material siding-cladding~~ shall be spaced not less than 1/2 ~~+~~ inch (19.1 mm) from the light straw-clay such that a ventilation space is created to allow for moisture diffusion. Furring strips that create this ventilation space shall be securely fastened to the stabilization members or framing. The siding-cladding shall be fastened to the wood furring strips in accordance with the manufacturer's instructions. Furring strips shall be spaced not more than 32 inches (813 mm) on center, and shall be securely fastened to the vertical wall reinforcing or structural framing. Insect screening shall be provided at the top and bottom of the ventilation space. An air barrier consisting of not more than 3/8 inch thick (9.5 mm) clay plaster or lime plaster shall be applied to the light straw-clay prior to the application of siding.

SECTION AR104 THERMAL INSULATION PERFORMANCE

AR104.1 R-value-Thermal characteristics. ~~Light Walls with light straw-clay, where installed infill of densities of greater than or equal to 20 pounds per cubic foot (480.6 kg/m³) shall be classified as mass walls in accordance with this appendix, Section N1102.2.5 and shall be deemed to have an R-value meet the R-value requirements for mass walls in Table N1102.1.2 (R402.1.2). Walls with light straw-clay infill of 4-6 densities less than 20 pounds per cubic foot (480.6 kg/m³) shall meet the R-value requirements for wood frame walls in Table N1102.1.1 (R402.1.2).~~

AR104.2 Thermal resistance. Light straw-clay shall be deemed to have a thermal resistance as specified in Table AR103.2.3.

Delete without substitution:

**SECTION AR105-
REFERENCED STANDARD**

ASTM E
2392/ E Standard Guide for Design of
2392M—10 Earthen Wall Building Systems AR103.3.2

**TABLE AR103.2.3
REQUIREMENTS AND PROPERTIES OF LIGHT STRAW-CLAY MIXTURES ^a**

Density (pcf)	Straw (pcf)	Subsoil (pcf)	Water (gal/cf) ^b	Min. % Clay in Subsoil	Min. Clay:Silt Ratio	Subsoil Testing Method ^{c,d}	Max. Wall Thickness, inches	R-Value (hr/F°/cf/BTU/inch)
<u>10</u>	<u>6.7</u>	<u>3.3</u>	<u>1.55</u>	<u>70</u>	<u>3.5:1</u>	<u>A</u>	<u>15</u>	<u>1.80</u>
<u>12</u>	<u>6.7</u>	<u>5.3</u>	<u>1.63</u>	<u>46</u>	<u>1.7:1</u>	<u>A</u>	<u>15</u>	<u>1.72</u>
<u>13</u>	<u>6.7</u>	<u>6.3</u>	<u>1.67</u>	<u>40</u>	<u>1.33:1</u>	<u>A</u>	<u>15</u>	<u>1.69</u>
<u>15</u>	<u>6.7</u>	<u>8.3</u>	<u>1.74</u>	<u>35</u>	<u>0.95:1</u>	<u>A</u>	<u>15</u>	<u>1.63</u>
<u>20</u>	<u>6.7</u>	<u>13.3</u>	<u>1.93</u>	<u>30</u>	<u>0.60:1</u>	<u>A</u>	<u>12</u>	<u>1.48</u>
<u>30</u>	<u>6.7</u>	<u>23.3</u>	<u>2.31</u>	<u>NA</u>	<u>NA</u>	<u>B</u>	<u>12</u>	<u>1.22</u>
<u>40</u>	<u>6.7</u>	<u>33.3</u>	<u>2.70</u>	<u>NA</u>	<u>NA</u>	<u>B</u>	<u>12</u>	<u>1.01</u>
<u>50</u>	<u>6.7</u>	<u>43.3</u>	<u>3.08</u>	<u>NA</u>	<u>NA</u>	<u>B</u>	<u>12</u>	<u>0.84</u>

© Douglas Piltingsrud and StrawClay.org. Used by permission.

a. Interpolation permitted. Extrapolation not permitted.

b. Water mixed with subsoil equals clay slip.

c. Subsoil Testing Methods:

A. Lab test for percent of clay, silt and sand via hydrometer method.

B. Ribbon Test of the Figure 3 Ball Test in the Appendix of ASTM E2392/E2392M.

d. Trace amounts of organic materials are acceptable.

**FIGURE AR103.2.4(1)
LIGHT STRAW-CLAY WALL WITH LARSEN TRUSSES**

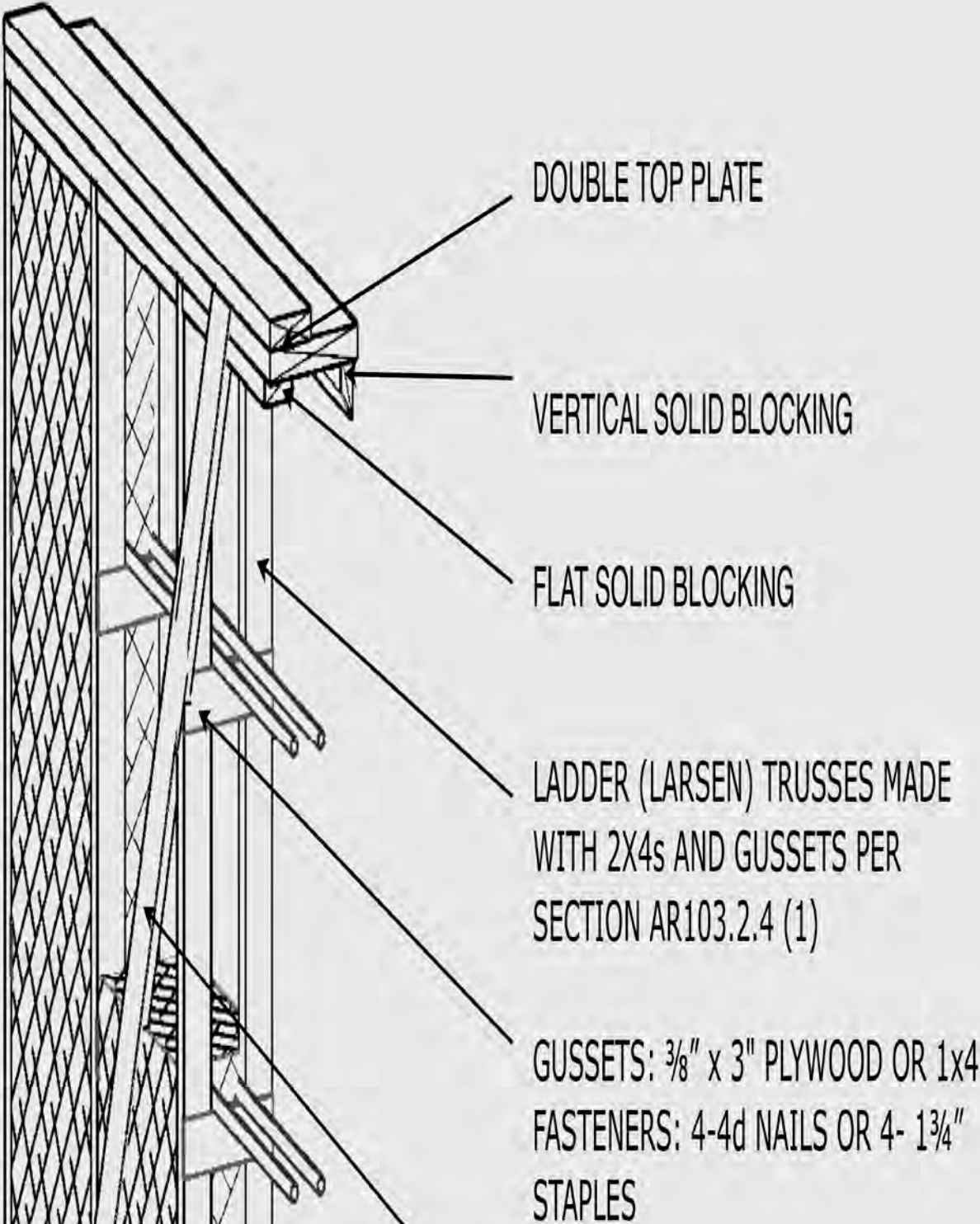


FIGURE AR103.2.4(2)
LIGHT STRAW-CLAY WALL SINGLE STUD WIDTH

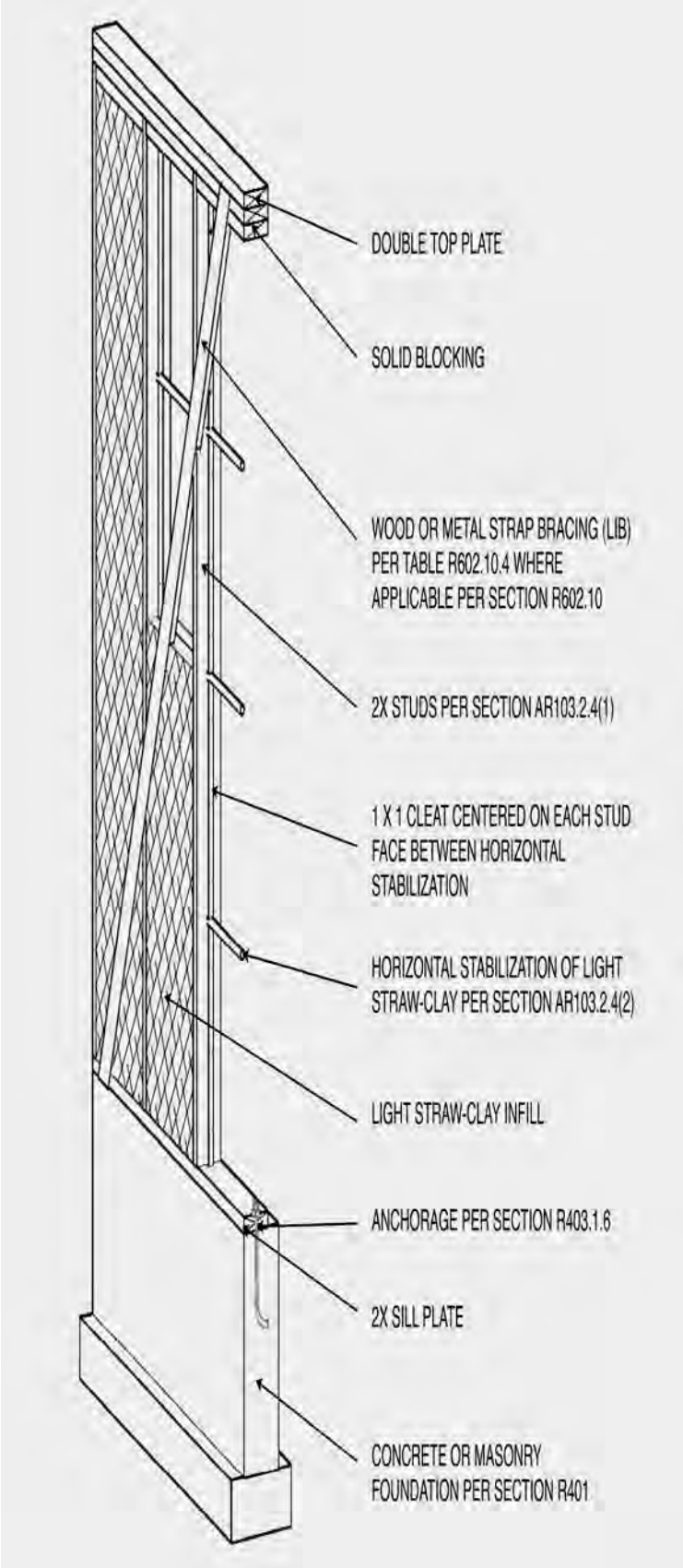
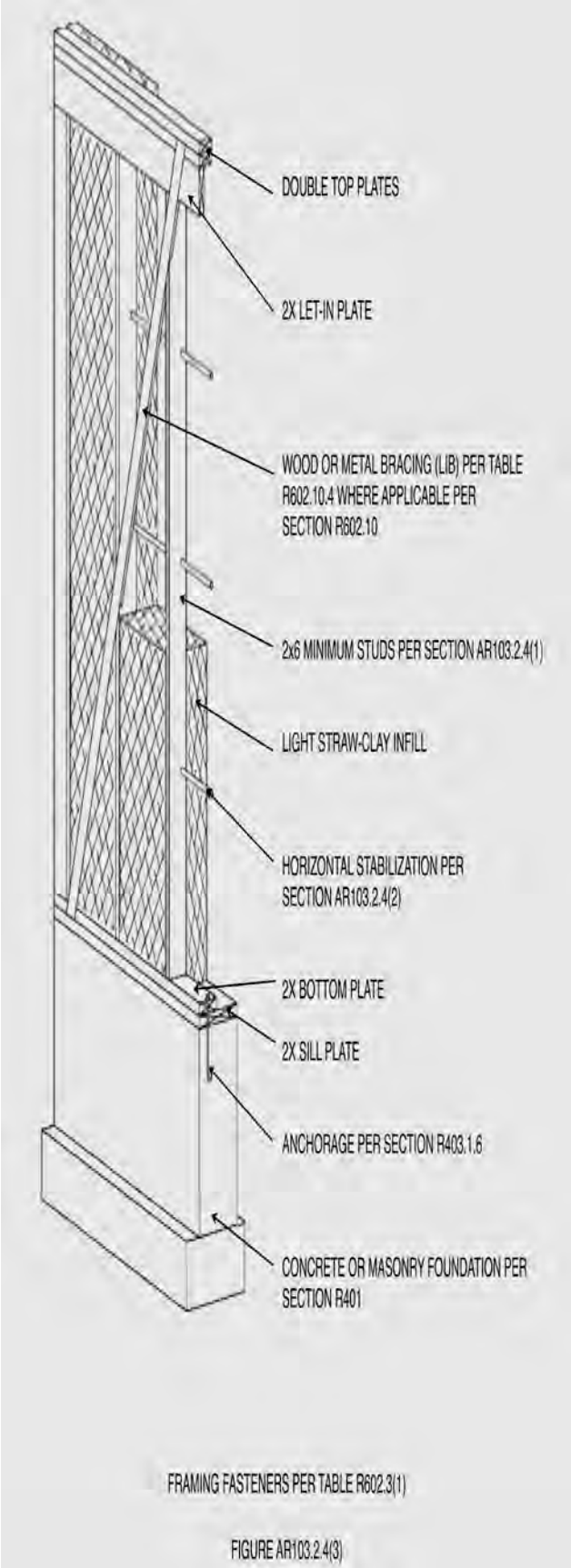


FIGURE AR103.2.4(3)
LIGHT STRAW-CLAY WALL WITH BLIND STUDS



Reason: Summary/Abstract: Updates to Appendix R Light Straw Clay Construction will provide clarification and incorporate new scientific information regarding material performance and construction methodology. This proposal adds new Figures and a Table, information previously published in the 2015 IRC Commentary Appendix R, and proposes text changes to certain Sections to coordinate with same.

Scope: Proposed additional text clarifies the scope of structural design requirements in seismic design zones.

Definitions: Several definitions are updated to be more accurate and congruent with other sections of this Appendix.

Bracing: Proposed text clarifies that lateral bracing at light straw-clay infill is confined to method LIB and solid sheathing is not allowed, but that other wall types within a building that do not use light straw-clay infill are permitted to use any bracing allowed in the code.

Table: Proposed Table is introduced. Further scientific testing has yielded data to more fully define light straw-clay materials and characteristics. Table AR103.2.3 covers the range of the requirements and properties of light straw-clay infill without limiting it to single specific weight. Text changes in subsequent sections refer to and coordinate with the new table.

Stabilization: Proposed substitution of the term 'stabilization' in lieu of 'reinforcement' as used previously. This clarifies the role of this element in light straw-clay construction, acknowledging that the term 'reinforcement' in construction is generally more commonly associated with the structural reinforcement of concrete.

The purpose of the stabilizing elements in light straw-clay infill is to ensure overall wall dimensional stability and to transfer out-of-plane lateral loads to structural members; not, as in concrete practice, the way steel reinforcing is used to impart tensile strength to the material. The use of the term stabilization here more accurately describes the functioning of the required vertical and horizontal members.

In addition, the introduction of three Figures previously included in the Appendix R 2015 Commentary serves to visually illustrate this stabilization and communicate its function more clearly.

Plaster: Proposed text distinguishes between densities of light straw-clay infill and creates requirements for evaluating the dimensional stability of the infill prior to plastering, appropriate to density of the infill.

Thermal: Performance of the wall thermally is outlined by proposed new table AR103.2.3 for varying densities, correlated to R-value. Table and text also clarify the design densities regulated distinctly as wood frame and as mass walls.

Where this 2015 Section currently provides a one-size-fits-all thermal definition, the proposed changes provide updated data that reflects further scientific tests and the advancement of construction techniques. Previously, the information in the proposed Table AR103.2.3 was available only in the Appendix R 2015 Commentary.

Proponents: The proposed changes are presented by a collaboration of North America's most experienced light straw-clay practitioners, representing over 2 decades of active research, design and construction of light straw-clay buildings across climate zones in Canada and the U.S. The team includes 3 architects, 2 builders, a structural engineer and a building materials scientist, and this proposal incorporates input from multiple other practitioners.

Bibliography: Econest—Creating Sustainable Sanctuaries of Clay, Straw and Timber. Paula Baker-Laporte, FAIA and Robert Laporte. Layton, UT: Gibbs Smith, 2005.

Resistance to Out-Of-Plane Lateral Forces of Light Straw Clay Wall Infill. Richard Duncan, PE.

http://www.econesthomes.com/wp-content/uploads/2013/01/Light-Straw-Clay-Out-of-Plane-Study-FINAL_merged.pdf, 2013.

Typical Outline Specifications for a Northern Light Straw-Clay House; The Affordable Natural House Contractor Training Reference Manual, 2nd Edition. Lou Host-Jablonski, AIA; Susan Thering, PhD, ed. Madison WI: University of Wisconsin-Extension, 2008.

An Introduction to the Science of Northern Light Straw-Clay Construction; The Affordable Natural House Contractor Training Reference Manual, 2nd Edition. Douglas Piltingsrud, PhD and Lou Host-Jablonski, AIA; Susan Thering, PhD, ed. Madison, WI: University of Wisconsin-Extension. 2008.

State of New Mexico Construction Industries Division Clay Straw Guidelines. Santa Fe, NM: State of NM CID publication. 2001.

StrawClay.org website. Madison, Wisconsin: Design Coalition, Inc., 2016.

USDA Forest Products Laboratory Engineering Report of Light Clay Specimens: Thermal Conductivities for Design Coalition's Straw/Clay Formulations Extend Volhard's K-Value vs. Density Curve in Low Conductivity End. Madison WI: USDA Forest Products Laboratory. 2004.

Initial Material Characterization of Straw Light Clay. Joshua Thornton. Ottawa, Ontario. Canada Mortgage and Housing Corporation, 2004.

2011 Oregon Reach Code—Section 1307. Country Club Hills, IL: International Code Council, Inc., 2012.

The EcoNest Home: Designing and Bulding a Light Straw Clay House. Paula Baker-Laporte, FAIA and Robert Laporte. BC, Canada 2015. New Society Publishers

Cost Impact: Will not increase the cost of construction

The changes proposed do not affect or change the cost of the design or construction of Light Straw-Clay from the existing 2015 IRC code.

**Report of Committee Action
Hearings**

Committee Action:

Approved as Submitted

Committee Reason: This proposal cleans up many items, including improving the thermal mass provisions to provide more exact calculations.

Assembly Action:

None

Final Action Results

RB365-16

AS

Code Change No: **RB366-16**

Original Proposal

Section: AS101.1, AS102.1, AS103.4, AS103.5, AS104.4.5, AS104.4.6, AS104.4.8, AS105.2, AS105.4, AS105.4.1, AS105.4.2, AS105.6.4, AS105.6.8, AS105.8 (New), AS106.11, AS106.12, AS106.13, AS106.13.1, AS106.5

Proponent: Martin Hammer, representing Martin Hammer, Architect (mfhammer@pacbell.net); Mark Aschheim, Santa Clara University, representing Santa Clara University (maschheim@scu.edu); David Eisenberg, Development Center for Appropriate Technology, representing Development Center for Appropriate Technology (strawnet@gmail.com); Jacob Racusin, New Frameworks Natural Design/Build, representing New Frameworks Natural Design/Build (jacob@newframeworks.com)

Revise as follows:

AS101.1 Scope. This appendix provides prescriptive and performance-based requirements for the use of baled straw as a building material. Other methods of strawbale construction shall be subject to approval in accordance with Section 104.11 of this code. Buildings using strawbale walls shall comply with ~~the~~ this code except as otherwise stated in this appendix.

AS102.1 Definitions. The following words and terms shall, for the purposes of this appendix, have the meanings shown herein. Refer to Chapter 2 of the *International Residential Code* for general definitions.

BALE. Equivalent to straw bale.

CLAY. Inorganic soil with particle sizes less than 0.00008 inch (0.002 mm) having the characteristics of high to very high dry strength and medium to high plasticity.

CLAY SLIP. A suspension of clay particles in water.

FINISH. Completed compilation of materials on the interior or exterior faces of stacked *bales*.

FLAKE. An intact section of compressed *straw* removed from an untied *bale*.

LAI D FLAT. The orientation of a bale with its largest faces horizontal, its longest dimension parallel with the wall plane, its *ties* concealed in the unfinished wall and its *straw* lengths oriented predominantly across the thickness of the wall.

LOAD-BEARING WALL. A strawbale wall that supports more than 100 pounds per linear foot (1459 N/m) of vertical load in addition its own weight.

MESH. An openwork fabric of linked strands of metal, plastic, or natural or synthetic fiber, ~~embedded in plaster.~~

NONSTRUCTURAL WALL. Walls other than load-bearing walls or shear walls.

ON-EDGE. The orientation of a *bale* with its largest faces vertical, its longest dimension parallel with the wall plane, its *ties* on the face of the wall and its *straw* lengths oriented predominantly vertically.

PIN. A vertical metal rod, wood dowel or bamboo, driven into the center of stacked bales, or placed on opposite surfaces of stacked bales and through-tied.

PLASTER. Gypsum or plaster, cement plaster, as defined in Sections R702 and AS104, or clay plaster, soil-cement plaster, lime plaster or cement-lime plaster as defined described in Section AS104.

PRECOMPRESSION. Vertical compression of stacked bales before the application of finish.

REINFORCED PLASTER. A plaster containing mesh reinforcement.

RUNNING BOND. The placement of *straw bales* such that the head joints in successive courses are offset not less than one-quarter the bale length.

SHEAR WALL. A strawbale wall designed and constructed to resist lateral seismic and wind forces parallel to the plane of the wall in accordance with Section AS106.13.

SKIN. The compilation of plaster and reinforcing, if any, applied to the surface of stacked bales.

STRUCTURAL WALL. A wall that meets the definition for a load-bearing wall or shear wall.

STACK BOND. The placement of straw bales such that head joints in successive courses are vertically aligned.

STRAW. The dry stems of cereal grains after the seed heads have been removed.

STRAW BALE. A rectangular compressed block of straw, bound by ties.

STRAWBALE. The adjective form of straw bale.

STRAW-CLAY. Loose straw mixed and coated with clay slip.

TIE. A synthetic fiber, natural fiber or metal wire used to confine a straw bale.

TRUTH WINDOW. An area of a strawbale wall left without its finish, to allow view of the straw otherwise concealed by its finish.

AS103.4 Moisture content. The moisture content of bales at the time of application of the first coat of plaster or the installation of another finish shall not exceed 20 percent of the weight of the bale. The moisture content of bales shall be determined by use of with a moisture meter designed for use with baled straw or hay, equipped with a probe of sufficient length to reach the center of the bale. Not less than 5 percent and not less than 10 bales used shall be randomly selected and tested.

AS103.5 Density. Bales shall have a dry density of not less than 6.5 pounds per cubic foot (104 kg/cubic meter). The dry density shall be calculated by subtracting the weight of the moisture in pounds (kg) from the actual bale weight and dividing by the volume of the bale in cubic feet (cubic meters). Not less than 2 percent and not less than five bales to be used shall be randomly selected and tested on site.

AS104.4.5 Gypsum plaster. Gypsum plaster shall comply with Section R702-R702.2.1. Gypsum plaster shall be limited to use on interior surfaces of nonstructural walls, and as an interior finish coat over a structural plaster that complies with this appendix.

AS104.4.6 Lime plaster. Lime plaster shall comply with Sections AS104.4.6.1 and through AS104.4.6.3.

AS104.4.8 Cement plaster. Cement plaster shall conform to ASTM C 926 and shall comply with Sections R703.6.2, R703.6.4R703.7.4 and R703.6.5R703.7.5, except that the amount of lime in plaster coats shall be not less than 1 part lime to 6 parts cement to allow a minimum acceptable vapor permeability. The combined thickness of plaster coats shall be not more than 1¹/₂ inches (38 mm) thick.

AS105.2 Building limitations and requirements for use of strawbale nonstructural walls. Buildings using strawbale nonstructural walls shall be subject to the following limitations and requirements:

1. Number of stories: not more than one, except that two stories shall be allowed with an *approved* engineered design.
2. Building height: not more than 25 feet (7620 mm), except that greater heights shall be allowed with an *approved* engineered design.
3. Wall height: in accordance with Table AS105.4.
4. ~~Braced wall panel length, and increase in Seismic Design Categories C, D₀, D₁ and D₂: the required length of bracing for buildings using strawbale nonstructural walls shall comply with Section R602.10.3 of this code, with the additional requirements that Table 602.10.3(3) shall be applicable to buildings in Seismic Design Category C, and that the minimum total length of braced wall panels in Table R602.10.3(3) shall be increased by 60 percent.~~
5. Braced wall panel lengths: in accordance with Section R602.10.3, with the additional requirements that Table R602.10.3(3) shall apply to all buildings in Seismic Design Category C, and that the minimum total length of braced wall panels in Table R602.10.3(3) shall be increased by 60 percent for buildings in Seismic Design Categories C, D₀, D₁ and D₂.

AS105.4 Out-of-plane resistance methods and unrestrained wall dimensions-dimension limits. Strawbale walls shall employ a method of out-of-plane load resistance in accordance with Table AS105.4, and comply with its associated limits and requirements.

AS105.4.1 Determination of out-of-plane loading. Out-of-plane loading for the use of Table AS105.4 shall be in terms of the ultimate design wind speed and seismic design category as determined in accordance with Sections R301.2.1 and R301.2.2 ~~of this code.~~

**TABLE AS105.4
OUT-OF-PLANE RESISTANCE METHODS AND UNRESTRAINED WALL DIMENSIONS-DIMENSION LIMITS**

METHOD OF OUT-OF-PLANE <u>LOAD RESISTANCE</u> ^a	FOR <u>ULTIMATE DESIGN WIND DESIGN SPEEDS</u> (mph)	FOR SEISMIC DESIGN CATEGORIES	UNRESTRAINED WALL DIMENSIONS, H ^b		MESH STAPLE SPACING AT BOUNDARY RESTRAINTS
			Absolute limit in feet	Limit based on bale thickness T ^c in feet (mm)	
Nonplaster finish or unreinforced plaster	≤ 400 <u>130</u>	A, B, C, D ₀	H ≤ 8	H ≤ 5T	None required
Pins per Section AS105.4.2	≤400 <u>130</u>	A, B, C, D ₀	H ≤ 12	H ≤ 8T	None required
Pins per Section AS105.4.2	≤ 440 <u>140</u>	A, B, C, D ₀ , D ₁ , D ₂	H ≤ 10	H ≤ 7T	None required
Reinforced ^{ed} clay plaster	≤ 440 <u>140</u>	A, B, C, D ₀ , D ₁ , D ₂	H ≤ 10	$H \leq 8T^{0.5} (H \leq 140T^{0.5})$	≤ 6 inches
Reinforced ^{ed} clay plaster	≤ 440 <u>140</u>	A, B, C, D ₀ , D ₁ , D ₂	10 H ≤ 12	$H \leq 8T^{0.5} (H \leq 140T^{0.5})$	≤ 4 inches ^e
Reinforced ^{ed} cement, cement-lime, lime or soil-cement plaster	≤ 440 <u>140</u>	A, B, C, D ₀ , D ₁ , D ₂	H ≤ 10	$H \leq 9T^{0.5} (H \leq 157T^{0.5})$	≤ 6 inches
Reinforced ^{ed} cement, cement-lime, lime or soil-cement plaster	≤ 420 <u>155</u>	A, B, C, D ₀ , D ₁ , D ₂	H ≤ 12	$H \leq 9T^{0.5} (H \leq 157T^{0.5})$	≤ 4 inches ^e

For SI: 1 inch = 25.4 mm, 1 foot = 304.8 mm.

- Finishes applied to both sides of stacked bales. Where different finishes are used on opposite sides of a wall, the more restrictive requirements shall apply.
- H = Stacked bale height in feet (mm) between sill plate and top plate or other *approved* horizontal restraint, or the horizontal distance in feet (mm) between *approved* vertical restraints. For load-bearing walls, H refers to vertical height only.
- T = Bale thickness in feet (mm).

- d. Plaster reinforcement shall be any mesh allowed in Table AS106.16 for the matching plaster type, and with staple spacing in accordance with this table. Mesh shall be installed in accordance with Section AS106.9.
- e. Sill plate attachment shall be with $5/8$ -inch anchor bolts or approved equivalent at not more than 48 inches on center where staple spacing is required to be ≤ 4 inches

AS105.4.2 Pins. Pins used for out-of-plane resistance shall comply with the following or shall be in accordance with an *approved* engineered design. Pins shall be external, internal or a combination of the two.

1. Pins shall be $1/2$ -inch-diameter (12.7 mm) steel, $3/4$ -inch-diameter (19.1 mm) wood or $1/2$ -inch-diameter (12.7 mm) bamboo.
2. External pins shall be installed vertically on both sides of the wall at a spacing of not more than 24 inches (610 mm) on center. External pins shall have full lateral bearing on the sill plate and the top plate or roof-bearing element, and shall be tightly tied through the wall to an opposing pin with ties spaced not more than 32 inches (813 mm) apart and not more than 8 inches (203 mm) from each end of the pins.
3. Internal pins shall be installed vertically within the center third of the bales, at spacing of not more than 24 inches (610 mm) and shall extend from top course to bottom course. The bottom course shall be ~~similarly~~ connected to its support and the top course shall be ~~similarly~~ connected to the roof- or floor-bearing member above with pins or other *approved* means. Internal pins shall be continuous or shall overlap through not less than one bale course.

AS105.6.4 Horizontal surfaces. Bale walls and other bale elements shall be provided with a water-resistant barrier at weather-exposed horizontal surfaces. The water-resistant barrier shall be of a material and installation that will prevent water from entering the wall system. Horizontal surfaces shall include exterior window sills, sills at exterior niches and buttresses. ~~The finish material at such~~ Horizontal surfaces shall be sloped not less than 1 unit vertical in 12 units horizontal (8-percent slope) and shall drain away from bale walls and elements. Where the water-resistant barrier is below the finish material, it shall be sloped not less than 1 unit vertical in 12 units horizontal (8-percent slope) and shall drain to the outside surface of the bales wall's vertical finish.

AS105.6.8 Separation of wood and plaster. Where wood framing or wood sheathing occurs ~~on~~ at the exterior face of strawbale walls, such wood surfaces shall be separated from exterior plaster with two layers of Grade D paper, No. 15 asphalt felt or other *approved* material in accordance with Section R703.6.3.

Exceptions:

1. Where the wood is preservative treated or *naturally durable* and is not greater than $1\ 1/2$ inches (38 mm) in width.
2. Clay plaster shall not be required to be separated from untreated wood that is not greater than $1\ 1/2$ inches (38 mm) in width.

AS105.8 Voids and stuffing Voids between bales and between bales and framing members shall not exceed 4 inches (102 mm) in width, and such voids shall be tightly stuffed with flakes, loose straw, or straw-clay before application of finish.

~~**AS106.5 Voids and stuffing.** Voids between bales in strawbale structural walls shall not exceed 4 inches (102 mm) in width, and such voids shall be stuffed with flakes of straw or straw-clay, before application of finish.~~

AS106.11 Transfer of loads to and from plaster skins. Where plastered strawbale walls are used to support superimposed vertical loads, such loads shall be transferred to the plaster *skins* by continuous direct bearing or by an *approved* engineered design. Where plastered strawbale walls are used to resist in-plane lateral loads, such loads shall be transferred to the reinforcing mesh from the structural member or assembly above and to the sill plate in accordance with Table ~~AS106.13(3)~~ AS106.13(1).

AS106.12 Load-bearing walls. Plastered strawbale walls shall be permitted to be used as load-bearing walls in one-story buildings to support vertical loads imposed in accordance with Section R301, in accordance with and not more than the allowable bearing capacities ~~indicated~~ in Table AS106.12.

AS106.13 Braced wall panels. *No change to text.*

AS106.13.1 Bale wall thickness. The thickness of the stacked bale strawbale braced wall panels without its plaster shall be not less than 15 inches (381 mm).

**TABLE AS106.13 (2)
BRACING REQUIREMENTS FOR STRAWBALE BRACED WALL PANELS BASED ON WIND SPEED**

EXPOSURE CATEGORY B ^d • 25-FOOT MEAN ROOF HEIGHT • 10-FOOT EAVE-TO-RIDGE HEIGHT ^d • 10-FOOT WALL HEIGHT ^d • 2 BRACED WALL LINES ^d			MINIMUM TOTAL LENGTH (FEET) OF STRAWBALE BRACED WALL PANELS REQUIRED ALONG EACH BRACED WALL LINE ^{a, b, c, d}			
Basic design wind speed (mph)	Ultimate wind speed (mph)	Story location	Braced wall line spacing (feet)	Strawbale braced wall panel ^e A2, A3	Strawbale braced wall panel ^e C1, C2, D1	Strawbale braced wall panel ^e B, D2, E1, E2
≤ 85	110	One-story building	10	6.4	3.8	3.0
			20	8.5	5.1	4.0
			30	10.2	6.1	4.8
			40	13.3	6.9	5.5
			50	16.3	7.7	6.1
			60	19.4	8.3	6.6
≤ 90	115	One-story building	10	6.4	3.8	3.0
			20	9.0 8.5	5.4 5.1	4.3 4.0
			30	11.2	6.4	5.1
			40	15.3 14.3	7.4 7.2	5.9 5.7
			50	18.4	8.1	6.5
			60	21.4	8.8	7.0
≤ 120	120	One-story building	10	7.1	4.3	3.4
			20	9.0	5.4	4.3
			30	12.2	6.6	5.3
			40	16.3	7.7	6.1
			50	19.4	8.3	6.6
			60	23.5	9.2	7.3
≤ 100	130	One-story building	10	7.1	4.3	3.4
			20	10.2	6.1	4.8
			30	14.3	7.2	5.7
			40	18.4	8.1	6.5
			50	22.4	9.0	7.1
			60	26.5	9.8	7.8
≤ 110	140	One-story building	10	7.8	4.7	3.7
			20	12.2 11.2	6.6 6.4	5.35 5.1
			30	17.3 16.3	7.9 7.7	6.36 6.1
			40	22.4 21.4	9.08 8.8	7.17 7.0
			50	26.5	9.8	7.8
			60	31.6 30.6	11.4 11.0	8.5 8.3

For SI: 1 inch = 25.4 mm, 1 foot = 305 mm, 1 mile per hour = 0.447 m/s.

- a. Linear interpolation shall be permitted.
- b. All braced wall panels shall be without openings and shall have an aspect ratio (H:L) ≤ 2:1.
- c. Tabulated minimum total lengths are for braced wall lines using single braced wall panels with an aspect ratio (H:L) ≤ 2:1, or using multiple braced wall panels with aspect ratios (H:L) ≤ 1:1. For braced wall lines using two or more braced wall panels with an aspect ratio (H:L) > 1:1, the minimum total length shall be multiplied by the largest aspect ratio (H:L) of braced wall panels in that line.
- d. Subject to applicable wind adjustment factors associated with "All methods" in Table R602.10.3(2)
- e. Strawbale braced panel types indicated shall comply with Sections AS106.13.1 through AS106.13.3 and with Table AS106.13(1).

**TABLE AS106.13 (3)
BRACING REQUIREMENTS FOR STRAWBALE BRACED WALL PANELS BASED ON SEISMIC DESIGN CATEGORY**

• SOIL CLASS D ^{ft} • WALL HEIGHT = 10 FEET ^d • 15 PSF ROOF-CEILING DEAD LOAD ^d • BRACED WALL LINE SPACING ≤ 25 FEET ^d			MINIMUM TOTAL LENGTH (FEET) OF STRAWBALE BRACED WALL PANELS REQUIRED ALONG EACH BRACED WALL LINE ^{a, b, c, d}	
Seismic Design Category	Story location	Braced wall line length (feet)	Strawbale Braced Wall Panele A2, C1, C2, D1	Strawbale Braced Wall Panele B, D2, E1, E2
C	One-story building	10	5.7	4.6
		20	8.0	6.5
		30	9.8	7.9
		40	12.9	9.1
		50	16.1	10.4
D ₀	One-story building	10	6.0	4.8
		20	8.5	6.8
		30	10.9	8.4
		40	14.5	9.7
		50	18.1	11.7
D ₁	One-story building	10	6.3	5.1
		20	9.0	7.2
		30	12.1	8.8
		40	16.1	10.4
		50	20.1	13.0
D ₂	One-story building	10	7.1	5.7
		20	10.1	8.1
		30	15.1	9.9
		40	20.1	13.0
		50	25.1	16.3

For SI: 1 inch = 25.4 mm, 1 foot = 305 mm, 1 pound per square foot = 0.0479 kPa.

a. Linear interpolation shall be permitted.

b. *Braced wall panels* shall be without openings and shall have an *aspect ratio* (H:L) ≤ 2:1.

c. Tabulated minimum total lengths are for *braced wall lines* using single *braced wall panels* with an *aspect ratio* (H:L) ≤ 2:1, or using multiple *braced wall panels* with *aspect ratios* (H:L) ≤ 1:1. For *braced wall lines* using two or more *braced wall panels* with an *aspect ratio* (H:L) > 1:1, the minimum total length shall be multiplied by the largest *aspect ratio* (H:L) of *braced wall panels* in that line.

d. Subject to applicable seismic adjustment factors associated with "All methods" in Table R602.10.3(4), except "Wall dead load."

e. Strawbale *braced wall panel* types indicated shall comply with Sections AS106.13.1 through AS106.13.3 and Table AS106.13(1).

f. Wall bracing lengths are based on a soil site class "D". Interpolation of bracing lengths between Sds values associated with the seismic design categories is allowable where a site-specific Sds value is determined in accordance with Section 1613.3 of the International Building Code.

Reason: The proposed changes in this proposal fall into one of the following three categories, and are needed to:

1. Simplify or clarify ambiguous language.
2. Correct typographical errors, errata, and changes to referenced section numbers in the IRC that changed from the 2012 to the 2015 IRC, but were not identified in Appendix S in the process of publishing the 2015 IRC.
3. Change "basic wind speed" to "ultimate design wind speed" terminology and wind speeds in Tables AS105.4 and AS106.13(2), and update associated braced wall panel lengths in Table AS106.13(2).

Example changes in category 1 include adding "predominantly" to the definition of "Laid Flat", and removing "similarly" in Section AS105.4.2

Example changes in category 2, include removing the word "the" in Section AS101.1, correcting the footnote in column 1 of Table AS105.4 from "c" to "d", and replacing R703.6.4 with R703.7.4 in Section AS104.4.8. Another change in this category is the inclusion of strawbale braced wall panel type 'B' in Table AS106.13(2), which was inadvertently left out of the proposal approved by ICC in 2013. Wall type 'B' should have been included with wall types D₁, E₁, and E₂ in the last column of that table. The changes in category 3 are necessary because of the change in use from "basic wind speed" to "ultimate design wind speed" from the 2012 IRC to the 2015 IRC. This proposal updates Tables AS105.4 and AS106.13(2) to use "ultimate design wind speed" to make them consistent with the rest of the IRC. Table R301.2.3.1 Wind Speed Conversions was used in converting "basic wind speeds" to "ultimate design wind speeds."

The revised values for "minimum total length of straw bale braced wall panel" in Table AS106.13(2) were determined using the same procedure as in the original proposal approved by ICC in 2013. A new row is included in Table AS106.13(2) that correlates with the added row in Table 602.10.3(1) in the 2015 IRC, with an ultimate design wind speed of 120 mph.

The basis for the braced wall panel lengths in Table AS106.13(2) is in a document posted on the following webpage: <http://ecobuildnetwork.org/projects/straw-bale-code-supporting-documents>

In Section AS105.2, the words "except that greater heights shall be allowed with an *approved* engineered design" are added to Item 2 to be consistent with the existing language in related item 1.

Existing Section AS106.3 Voids and stuffing is moved from AS106 Structural to AS105 General to become Section AS105.8 because stuffing of voids is important not only for structural performance, but to ensure proper thermal performance and fireblocking for all strawbale walls. The content of the relocated section is the same, but with the important condition of voids between bales and framing members added.

Footnote 'f' is added to Table AS106.13(3) to be consistent with footnote 'b' in the correlating braced wall panel table in the IRC, Table R602.10.3(3).

Bibliography: <http://ecobuildnetwork.org/projects/straw-bale-code-supporting-documents>

Cost Impact: Will not increase the cost of construction

The proposed changes in this proposal address matters of ambiguous language and corrections of errata. Therefore they have no cost impact.

Report of Committee Action Hearings
--

Committee Action:

Approved as Submitted

Committee Reason: This proposal clarifies and improves the code, corrects errors and updates the wind speed terminology.

Assembly Action:

None

Final Action Results

RB366-16

AS

Code Change No: RB367-16

Original Proposal

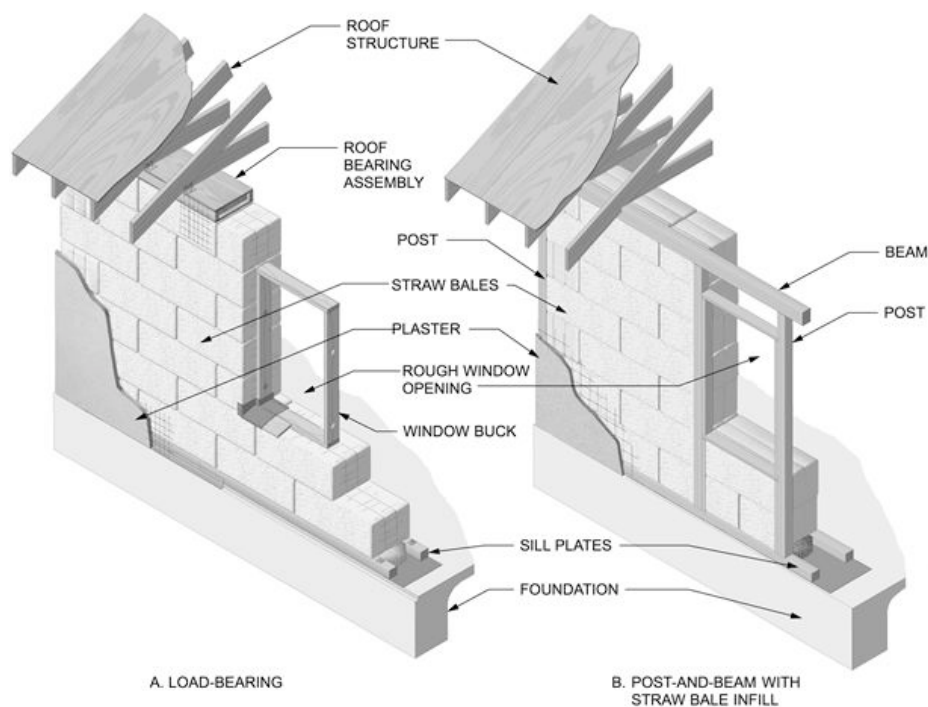
Section: AS101.2 (New), AS102.1, AS103.2, AS103.2 (New), AS105.1, AS105.1(1) (New), AS105.1(2) (New), AS105.1(3) (New), AS105.1(4) (New), AS105.3, AS106.10, AS106.11, AS106.12.3 (New), AS106.12.3.1 (New), AS106.15 (New), AS106.3

Proponent: Martin Hammer, representing Martin Hammer, Architect (mfhammer@pacbell.net); David Eisenberg, representing Development Center for Appropriate Technology

Revise as follows:

AS101.2 Strawbale wall systems. Strawbale wall systems include those shown in Figure AS101.2 and *approved variations*.

**FIGURE AS101.2
TYPICAL STRAWBALE WALL SYSTEMS**



NOTE: SEE FIGURES AS105.1(1) THROUGH AS105.1(4) FOR DETAILED VIEWS AND SECTION REFERENCES. OTHER STRAWBALE WALL SYSTEMS OR VARIATIONS ARE PERMITTED AS APPROVED.

AS102.1 Definitions. The following words and terms shall, for the purposes of this appendix, have the meanings shown herein. Refer to Chapter 2 of the *International Residential Code* for general definitions.

BALE. Equivalent to straw bale.

CLAY. Inorganic soil with particle sizes less than 0.00008 inch (0.002 mm) having the characteristics of high to very high dry strength and medium to high plasticity.

CLAY SLIP. A suspension of clay particles in water.

FINISH. Completed compilation of materials on the interior or exterior faces of stacked *bales*.

FLAKE. An intact section of compressed *straw* removed from an untied *bale*.

LAI D FLAT. The orientation of a bale with its largest faces horizontal, its longest dimension parallel with the wall plane, its *ties* concealed in the unfinished wall and its *straw* lengths oriented across the thickness of the wall. See Figure AS102.1.

LOAD-BEARING WALL. A strawbale wall that supports more than 100 pounds per linear foot (1459 N/m) of vertical load in addition its own weight.

MESH. An openwork fabric of linked strands of metal, plastic, or natural or synthetic fiber, embedded in plaster.

NONSTRUCTURAL WALL. Walls other than load-bearing walls or shear walls.

ON-EDGE. The orientation of a *bale* with its largest faces vertical, its longest dimension parallel with the wall plane, its *ties* on the face of the wall and its *straw* lengths oriented vertically. See Figure AS102.1.

ON-END. The orientation of a *bale* with its longest dimension vertical. For use in nonstructural strawbale walls only. See Figure AS102.1.

PIN. A vertical metal rod, wood dowel or bamboo, driven into the center of stacked bales, or placed on opposite surfaces of stacked bales and through-tied.

PLASTER. Gypsum or cement plaster, as defined in Sections R702 and AS104, or clay plaster, soil-cement plaster, lime plaster or cement-lime plaster as defined in Section AS104.

PRECOMPRESSION. Vertical compression of stacked bales before the application of finish.

REINFORCED PLASTER. A plaster containing mesh reinforcement.

RUNNING BOND. The placement of *straw bales* such that the head joints in successive courses are offset not less than one-quarter the bale length.

SHEAR WALL. A strawbale wall designed and constructed to resist lateral seismic and wind forces parallel to the plane of the wall in accordance with Section AS106.13.

SKIN. The compilation of plaster and reinforcing, if any, applied to the surface of stacked bales.

STRUCTURAL WALL. A wall that meets the definition for a load-bearing wall or shear wall.

STACK BOND. The placement of straw bales such that head joints in successive courses are vertically aligned.

STRAW. The dry stems of cereal grains after the seed heads have been removed.

STRAW BALE. A rectangular compressed block of straw, bound by ties.

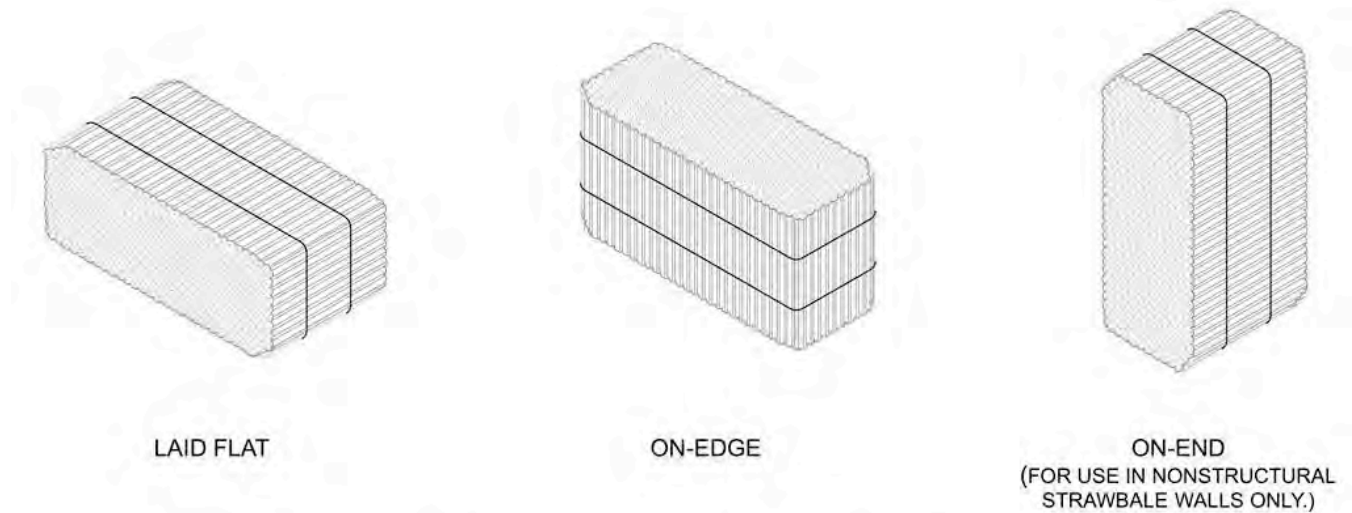
STRAWBALE. The adjective form of straw bale.

STRAW-CLAY. Loose straw mixed and coated with clay slip.

TIE. A synthetic fiber, natural fiber or metal wire used to confine a straw bale.

TRUTH WINDOW. An area of a strawbale wall left without its finish, to allow view of the straw otherwise concealed by its finish.

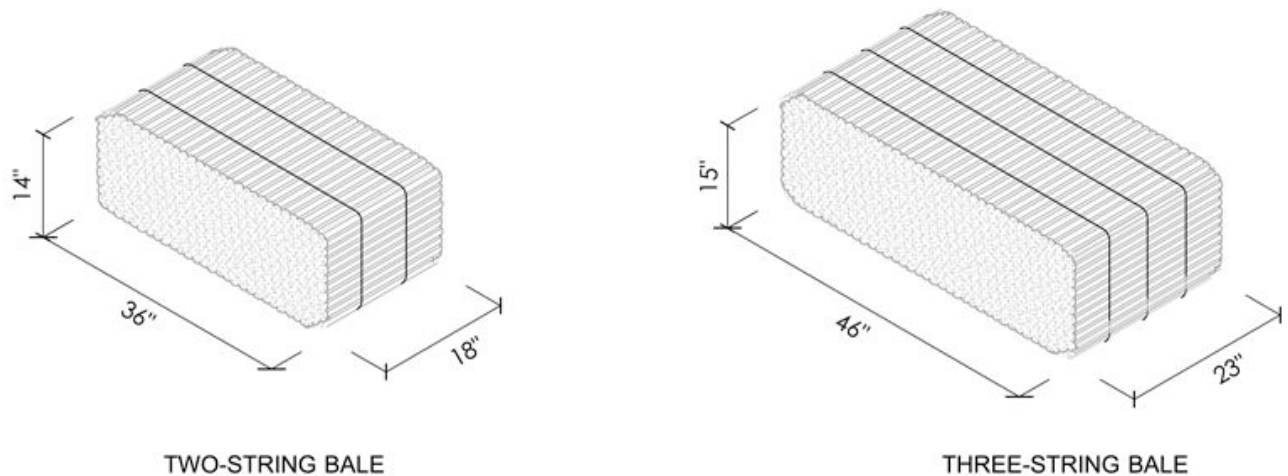
FIGURE AS101.2
BALE ORIENTATIONS



NOTE: ILLUSTRATIONS ALSO SHOW THE PREDOMINANT DIRECTION OF THE LENGTHS OF STRAW IN A TYPICAL STRAW BALE. HOWEVER, SOME RANDOMNESS OF DIRECTION IS NORMAL.

AS103.2 Size. Bales shall have a height and thickness of not less than 12 inches (305 mm), except as otherwise permitted or required in this appendix. Bales used within a continuous wall shall be of consistent height and thickness to ensure even distribution of loads within the wall system. See Figure AS103.2 for approximate dimensions of common straw bales.

FIGURE AS103.2
APPROXIMATE DIMENSIONS OF COMMON STRAW BALES



For SI: 1 inch = 25.4 mm

AS105.1 General. Strawbale walls shall be designed and constructed in accordance with this section and with Figures AS105.1(1) through AS105.1(4) or an *approved* alternative design. Strawbale structural walls shall be in accordance with the additional requirements of Section AS106.

AS105.3 Sill plates. Sill plates shall be installed in accordance with Figure AS105.3(1) or AS105.3(2). Sill plates shall support and be flush with each face of the straw bales above and shall be of naturally durable or preservative-treated wood where required by this code. Sill plates shall be not less than nominal 2 inches by 4 inches (51 mm by 102 mm) with anchoring complying with Section R403.1.6 and the additional requirements of Tables AS105.4 and AS106.6(1), where applicable.

AS106.3 Foundations. Foundations for plastered strawbale walls shall be in accordance with Chapter 4, Figure AR105.1(1) or Figure AR105.1(2).

AS106.10 Support of plaster skins. Plaster *skins* on strawbale structural walls shall be continuously supported along their bottom edge. Acceptable supports include: a concrete or masonry stem wall, a concrete slab-on-grade, a wood-framed floor blocked in accordance with Figure AS105.1(2) and an *approved* engineered design, or a steel angle anchored with an *approved* engineered design. A weep screed as described in Section R703.7.2.1 is not an acceptable support.

AS106.11 Transfer of loads to and from plaster skins. Where plastered strawbale walls are used to support superimposed vertical loads, such loads shall be transferred to the plaster *skins* by continuous direct bearing in accordance with Figure AS105.1(3) or by an *approved* engineered design. Where plastered strawbale walls are used to resist in-plane lateral loads, such loads shall be transferred to the reinforcing mesh from the structural member or assembly above in accordance with Figure AS105.1(3) or AS105.1(4) and to the sill plate in accordance with Figure AS105.1(1) or AS105.1(2) and with Table AS106.13(3) AS106.13(1).

AS106.12.3 Roof bearing assembly. Roof bearing assemblies shall be of nominal 2-inch by 6-inch (51 mm by 152 mm) lumber with 15/32-inch (12 mm) plywood or OSB panels fastened with 8d nails at 6 inches (152 mm) o.c. in accordance with Figure AS105.1(3) and Items 1 through 4, or be of an *approved* engineered design.

1. Discontinuous lumber shall be spliced with a metal strap with not less than a 500 pound (2224 N) allowable wind or seismic load tension capacity. Where the wall line includes a braced wall panel

- the strap shall have not less than a 2000 pound (8896 N) capacity.
- 2. Panel joints shall be blocked.
- 3. Roof and ceiling framing shall be attached to the roof bearing assembly in accordance with Table R602.3(1) Items 2 and 6.
- 4. Where the roof bearing assembly spans wall openings it shall comply with Section AS106.12.3.1

AS106.12.3.1 Roof bearing assembly spanning openings. Roof bearing assemblies that span openings in strawbale walls shall comply with the following at each opening:

- 1. Lumber on each side of the assembly shall be of the dimensions and quantity required to span each opening in accordance with Table R602.7(1).
- 2. The required lumber in the assembly shall be supported at each side of the opening by the number of jack studs required by Table R602.7(1), or shall extend beyond the opening on both sides a distance D, using the following formula:

$$D = S \times R / 2 / (1 - R)$$

where:

D = minimum distance (in feet) for required spanning lumber to extend beyond the opening

S = span in feet

$R = B_L / B_C$

B_L = design load on the wall (in pounds per lineal foot) in accordance with Sections R301.4 and R301.6

B_C = allowable bearing capacity of the wall in accordance with Table AS106.12

AS106.15 Post-and-beam with strawbale infill. Post-and-beam with strawbale infill systems shall be in accordance with Figure AS105.1(4) and Items 1 through 6, or be of an *approved* engineered design.

- 1. Beams shall be of the dimensions and number of members in accordance with Table R602.7(1), where the space between posts equals the span in the table.
- 2. Beam ends shall bear over posts not less than 1 1/2 inches (38 mm) or be supported by a framing anchor in accordance with Table R602.7(1).
- 3. Discontinuous beam ends shall be spliced with a metal strap with not less than 1000 pound (4448 kg) wind or seismic load tension capacity. Where the wall line includes a braced wall panel the strap shall have a not less than a 4000 pound (17,793 kg) capacity.
- 4. Each post shall equal $NJ + 1$ in accordance with Table R602.7(1), where the space between posts equals the span in the table.
- 5. Posts shall be connected to the beam with an *approved* means.
- 6. Roof and ceiling framing shall be attached to the beam in accordance with Table R602.3(1) Items 2 and 6.

FIGURE AS105.1(1)
TYPICAL BASE OF PLASTERED STRAWBALE WALL ON CONCRETE SLAB AND FOOTING

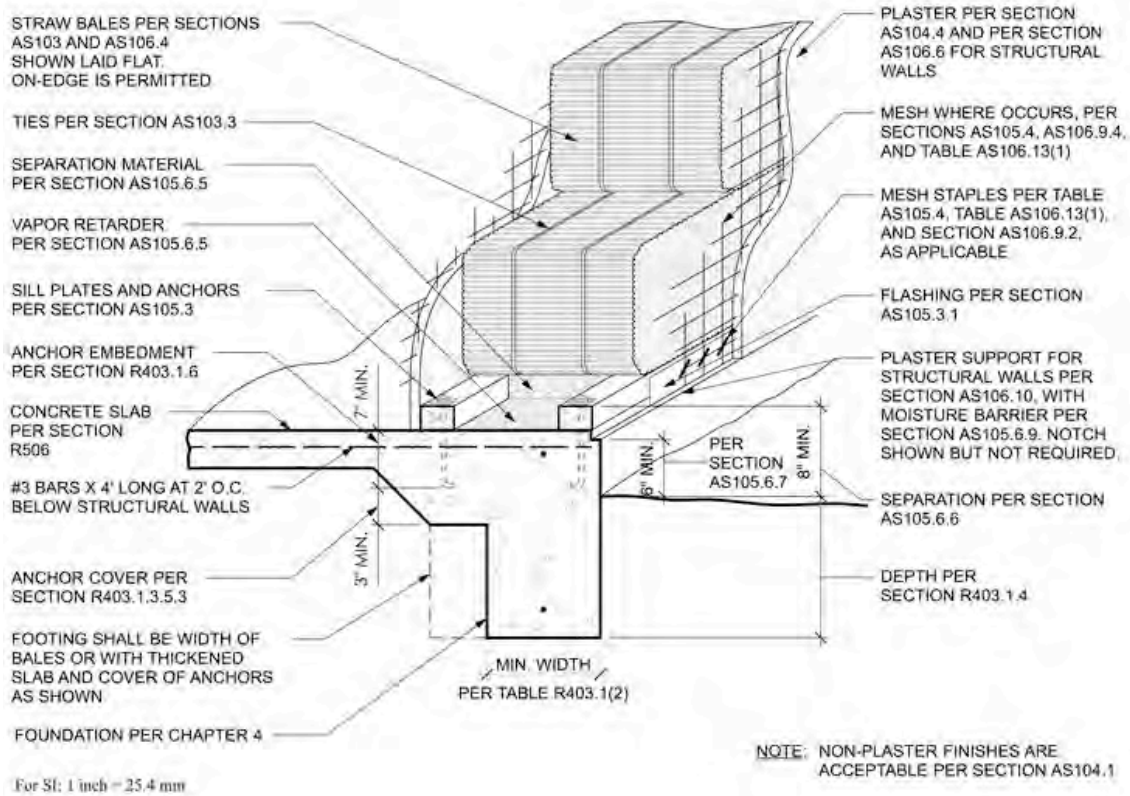
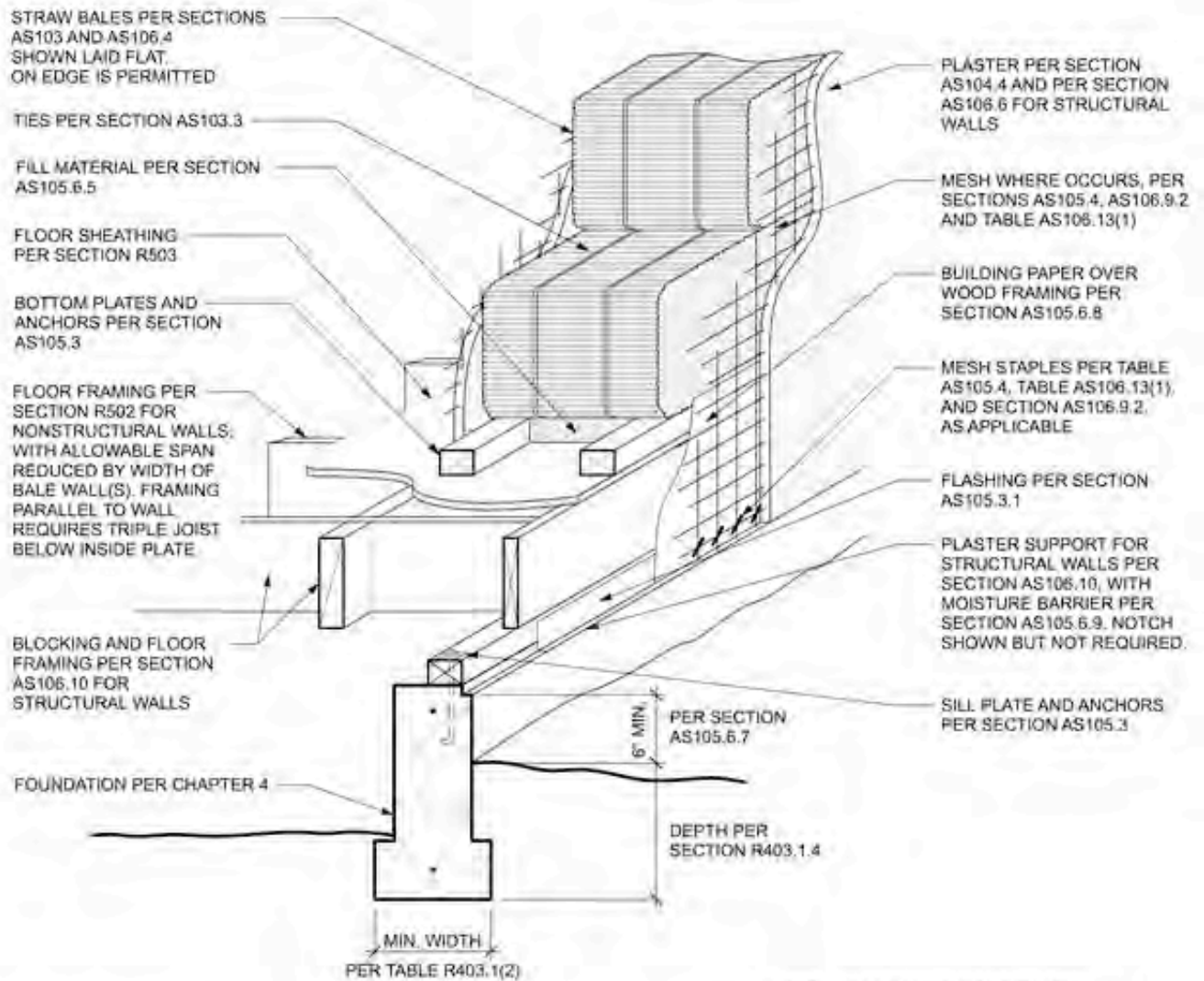


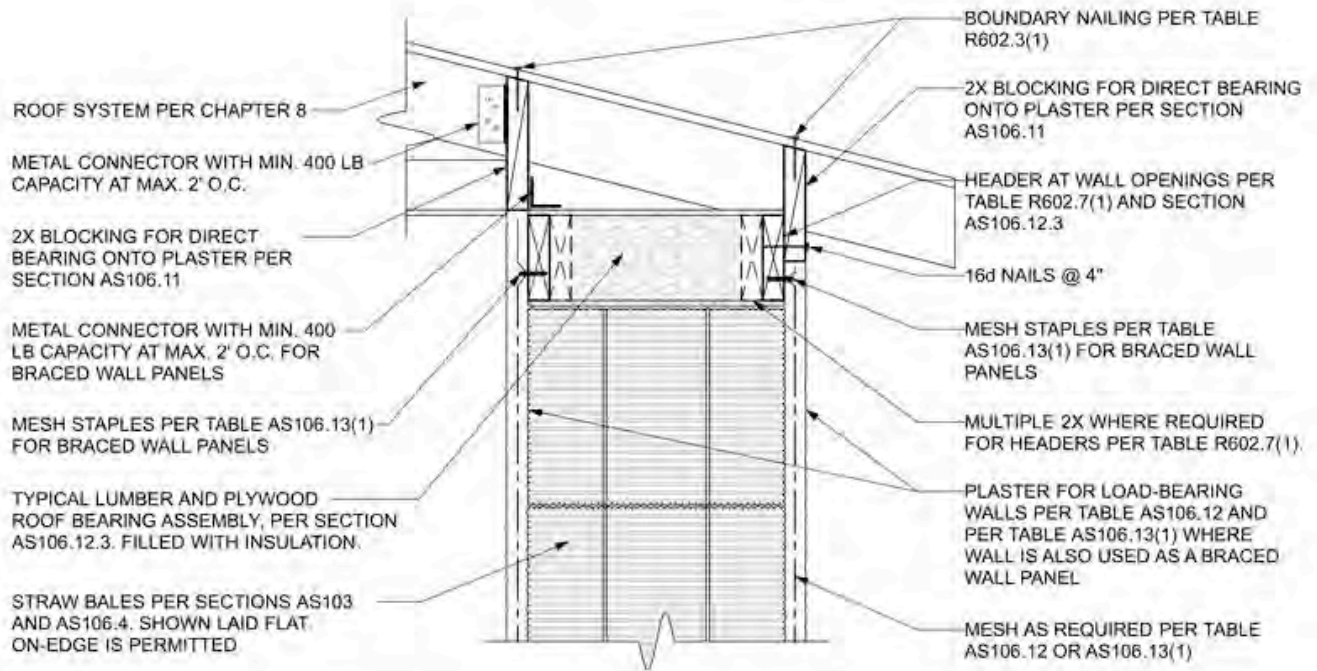
FIGURE AS105.1(2)
TYPICAL BASE OF PLASTERED STRAWBALE WALL OVER RAISED FLOOR



1 inch = 25.4 mm

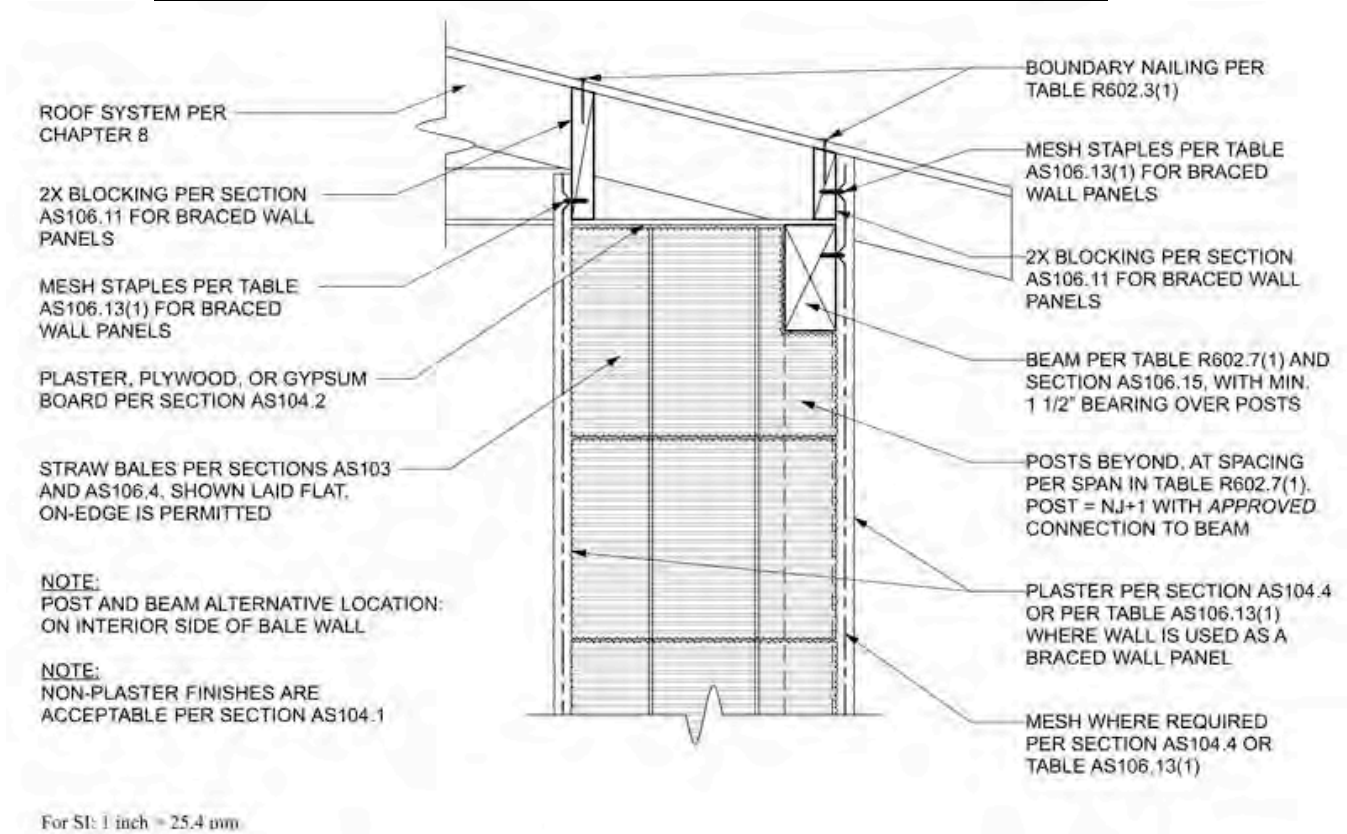
NOTE: NON-PLASTER FINISHES ARE ACCEPTABLE PER SECTION AS104.1

FIGURE AS105.1(3)
TYPICAL TOP OF LOAD-BEARING STRAWBALE WALL



For SI: 1 inch = 25.4 mm

FIGURE AS105.1(4)
TYPICAL TOP OF POST-AND-BEAM WALL WITH PLASTERED STRAW BALE INFILL



Reason: This proposal brings seven Figures that illustrate strawbale wall systems and their components from the Commentary into Appendix S. Many design professionals, builders, and building officials are unfamiliar with strawbale construction, and these Figures provide clear visualization of the primary components of the most common systems of strawbale construction. The Figures reference appendix sections and their associated requirements. The callout text of the Commentary Figures was modified in some cases to make the Figures suitable for inclusion in the Appendix.

Sections AS106.12.3 Roof bearing assembly, and AS106.15 Post-and-beam with strawbale infill, are added to bring requirements from the figures into the body of the appendix. These requirements are complete, whereas the requirements in the figures in the commentary of the 2015 IRC are not. Engineering analysis justifying these requirements are posted at: <http://ecobuildnetwork.org/projects/straw-bale-code-supporting-documents>

Ten registered design professionals and builders with extensive experience in strawbale construction in different climates and regions of the United States had input in the creation of these Figures. At least half of these practitioners have experience with strawbale buildings in high seismic zones.

Bibliography: <http://ecobuildnetwork.org/projects/straw-bale-code-supporting-documents>

Cost Impact: Will not increase the cost of construction

The proposed Figures depict components of strawbale wall systems and illustrate requirements that already exist in Appendix S. Therefore there is no cost impact.

**Report of Committee Action
Hearings**

Committee Action:

Approved as Submitted

Committee Reason: The figures add clarity and help users.

Assembly Action:

None

Final Action Results

RB367-16

AS

Code Change No: **RB368-16**

Original Proposal

Section: AS102.1, AS104.2, AS104.4.3.1, AS104.4.3.2, AS104.4.4.1, AS105.3.1 (New), AS105.4, AS105.6, AS105.6.9 (New), AS106.1, AS106.12.3 (New), AS106.12.3.1 (New), AS106.12.5 (New), AS106.2 (New), AS108.1, AS108.2 (New), AS109

Proponent: Martin Hammer, representing Martin Hammer, Architect (mfhammer@pacbell.net); David Eisenberg, representing Development Center for Appropriate Technology

Revise as follows:

AS102.1 Definitions. The following words and terms shall, for the purposes of this appendix, have the meanings shown herein. Refer to Chapter 2 of the *International Residential Code* for general definitions.

BALE. Equivalent to straw bale.

CLAY. Inorganic soil with particle sizes less than 0.00008 inch (0.002 mm) having the characteristics of high to very high dry strength and medium to high plasticity.

CLAY SLIP. A suspension of clay ~~particles~~ subsoil in water.

CLAY SUBSOIL. Subsoil sourced directly from the earth or refined, containing clay and free of organic matter.

FINISH. Completed compilation of materials on the interior or exterior faces of stacked *bales*.

FLAKE. An intact section of compressed *straw* removed from an untied *bale*.

LAI D FLAT. The orientation of a bale with its largest faces horizontal, its longest dimension parallel with the wall plane, its *ties* concealed in the unfinished wall and its *straw* lengths oriented across the thickness of the wall.

LOAD-BEARING WALL. A strawbale wall that supports more than 100 pounds per linear foot (1459 N/m) of vertical load in addition its own weight.

MESH. An openwork fabric of linked strands of metal, plastic, or natural or synthetic fiber, embedded in plaster.

NONSTRUCTURAL WALL. Walls other than load-bearing walls or shear walls.

ON-EDGE. The orientation of a *bale* with its largest faces vertical, its longest dimension parallel with the wall plane, its *ties* on the face of the wall and its *straw* lengths oriented vertically.

ON-END. The orientation of a *bale* with its longest dimension vertical. For use in nonstructural strawbale walls only.

PIN. A vertical metal rod, wood dowel or bamboo, driven into the center of stacked bales, or placed on opposite surfaces of stacked bales and through-tied.

PLASTER. Gypsum or cement plaster, as defined in Sections R702 and AS104, or clay plaster, soil-cement plaster, lime plaster or cement-lime plaster as defined in Section AS104.

PRECOMPRESSION. Vertical compression of stacked bales before the application of finish.

REINFORCED PLASTER. A plaster containing mesh reinforcement.

RUNNING BOND. The placement of *straw bales* such that the head joints in successive courses are offset not less than one-quarter the bale length.

SHEAR WALL. A strawbale wall designed and constructed to resist lateral seismic and wind forces parallel to the plane of the wall in accordance with Section AS106.13.

SKIN. The compilation of plaster and reinforcing, if any, applied to the surface of stacked bales.

STRUCTURAL WALL. A wall that meets the definition for a load-bearing wall or shear wall.

STACK BOND. The placement of straw bales such that head joints in successive courses are vertically aligned.

STRAW. The dry stems of cereal grains after the seed heads have been removed.

STRAW BALE. A rectangular compressed block of straw, bound by ties.

STRAWBALE. The adjective form of straw bale.

STRAW-CLAY. Loose straw mixed and coated with clay slip.

TIE. A synthetic fiber, natural fiber or metal wire used to confine a straw bale.

TRUTH WINDOW. An area of a strawbale wall left without its finish, to allow view of the straw otherwise concealed by its finish.

AS104.2 Purpose, and where required. Strawbale walls shall be finished so as to provide mechanical protection, fire resistance and protection from weather and to restrict the passage of air through the bales, in accordance with this appendix and this code. Vertical strawbale wall surfaces shall receive a coat of plaster not less than $\frac{3}{8}$ inch (10 mm) thick, or greater where required elsewhere in this appendix, or shall fit tightly against a solid wall panel or dense-packed cellulose insulation with a density of not less than 3.5 pounds per cubic foot (56 kg/cubic meter) blown into an adjacent framed wall. The tops of strawbale walls shall receive a coat of plaster not less than $\frac{3}{8}$ inch (10 mm) thick where straw would otherwise be exposed.

Exception: Truth windows shall be permitted where a fire-resistance rating is not required. Weather-exposed truth windows shall be fitted with a weather-tight cover. Interior truth windows in Climate Zones 5, 6, 7, 8 and Marine 4 shall be fitted with an air-tight cover.

AS104.4.3.1 General. Clay plaster shall be any plaster having a clay or ~~clay soil~~ clay subsoil binder. Such plaster shall contain sufficient clay to fully bind the ~~plaster,~~ sand or other inert granular material, and shall be permitted to contain reinforcing fibers. Acceptable reinforcing fibers include chopped straw, sisal and animal hair.

AS104.4.3.2 ~~Lath and mesh~~ Clay subsoil requirements. ~~Clay plaster shall not be required to contain reinforcing lath or mesh except as required in Tables AS105.4 and AS106.13(1). Where provided, mesh~~ The suitability of clay subsoil shall be natural fiber, corrosion-resistant metal, nylon, high-density polypropylene determined in accordance with the Figure 2 Ribbon Test or other approved material the Figure 3 Ball Test in the appendix of ASTM E2392/E2392M.

AS104.4.4.1 General. Soil-cement plaster shall be composed of soil (free of organic matter) clay subsoil, sand and not less than 10 percent and not more than 20 percent Portland cement by volume, and shall be permitted to contain reinforcing fibers.

AS105.3.1 Exterior sill plate flashing. Exterior sill plates shall receive flashing across plate to slab or foundation joints.

TABLE AS105.4
OUT-OF-PLANE RESISTANCE METHODS AND UNRESTRAINED WALL DIMENSIONS-DIMENSION LIMITS

METHOD OF OUT-OF-PLANE RESISTANCE ^a	FOR ULTIMATE DESIGN WIND DESIGN SPEEDS (mph)	FOR SEISMIC DESIGN CATEGORIES	UNRESTRAINED WALL DIMENSIONS, H ^b		MESH STAPLE SPACING AT BOUNDARY RESTRAINTS
			Absolute limit in feet	Limit based on bale thickness T ^c in feet (mm)	
Nonplaster finish or unreinforced plaster	≤ 130	A, B, C, D ₀	H ≤ 8	H ≤ 5T	None required
Pins per Section AS105.4.2	≤ 130	A, B, C, D ₀	H ≤ 12	H ≤ 8T	None required
Pins per Section AS105.4.2	≤ 140	A, B, C, D ₀ , D ₁ , D ₂	H ≤ 10	H ≤ 7T	None required
Reinforced ^{ed} clay plaster	≤ 140	A, B, C, D ₀ , D ₁ , D ₂	H ≤ 10	$H \leq 8T^{0.5}$ ($H \leq 140T^{0.5}$)	≤ 6 inches
Reinforced ^{ed} clay plaster	≤ 140	A, B, C, D ₀ , D ₁ , D ₂	10 H ≤ 12	$H \leq 8T^{0.5}$ ($H \leq 140T^{0.5}$)	≤ 4 inches ^e
Reinforced ^{ed} cement, cement-lime, lime or soil-cement plaster	≤ 140	A, B, C, D ₀ , D ₁ , D ₂	H ≤ 10	$H \leq 9T^{0.5}$ ($H \leq 157T^{0.5}$)	≤ 6 inches
Reinforced ^{ed} cement, cement-lime, lime or soil-cement plaster	≤ 155	A, B, C, D ₀ , D ₁ , D ₂	H ≤ 12	$H \leq 9T^{0.5}$ ($H \leq 157T^{0.5}$)	≤ 4 inches ^e
2x6 load-bearing studs ^f at max. 6' o.c.	≤ 140	A, B, C, D ₀ , D ₁ , D ₂	H ^g ≤ 9	NA	None required
2x6 load-bearing studs ^f at max. 4' o.c.	≤ 140	A, B, C, D ₀ , D ₁ , D ₂	H ^g ≤ 10	NA	None required
2x6 load-bearing studs ^f at max. 2' o.c.	≤ 140	A, B, C, D ₀ , D ₁ , D ₂	H ^g ≤ 12	NA	None required
2x4 load-bearing studs ^f at max. 2' o.c.	≤ 140	A, B, C, D ₀ , D ₁ , D ₂	H ^g ≤ 10	NA	None required
2x6 nonload-bearing studs ^f at max. 6' o.c.	≤ 140	A, B, C, D ₀ , D ₁ , D ₂	H ^g ≤ 12	NA	None required

For SI: 1 inch = 25.4 mm, 1 foot = 304.8 mm.

a. Finishes applied to both sides of stacked bales. Where different finishes are used on opposite sides of a wall, the more restrictive requirements shall apply.

b. H = Stacked bale height in feet (mm) between sill plate and top plate or other approved horizontal restraint, or the horizontal distance in feet (mm) between approved vertical restraints. For load-bearing walls, H refers to vertical height only.

c. T = Bale thickness in feet (mm).

d. Plaster reinforcement shall be any mesh allowed in Table AS106.16 for the matching plaster type, and with staple spacing in accordance with this table. Mesh shall be installed in accordance with Section AS106.9.

e. Sill plate attachment shall be with 5/8-inch anchor bolts or approved equivalent at not more than 48 inches on center where staple spacing is required to be ≤ 4 inches

f. Bales shall be attached to the studs by an approved method. Horizontal framing and attachment at top and bottom of studs shall be in accordance with Section R602 or an approved alternative. Table R602.7(1) shall be used to determine the top framing member where load-bearing stud spacing exceeds 24-inches o.c.
g. H is vertical height only.

AS105.6 Moisture control. Strawbale walls shall be protected from moisture intrusion and damage in accordance with Sections AS105.6.1 through ~~AS105.6.8~~AS105.6.9.

AS105.6.9 Separation of exterior plaster and foundation. Exterior plaster shall be separated from the building foundation with a moisture barrier.

AS106.1 General. Plastered strawbale walls shall be permitted to be used as structural walls in ~~one-story buildings~~ in accordance with the prescriptive provisions of this section.

AS106.2 Building limitations and requirements for use of strawbale structural walls. Buildings using strawbale *structural* walls shall be subject to the following limitations and requirements:

1. Number of stories: Not more than one.
2. Building height: Not more than 25 feet (7620 mm).
3. Wall height: In accordance with Tables AS105.4, AS106.13(2) and AS106.13(3) as applicable, whichever is most restrictive.
4. Braced wall panel lengths: The greater of the values determined in accordance with Tables AS106.13(2) and AS106.13(3) for buildings using strawbale braced wall panels, or in accordance with Section AS105.2(4) for buildings with load-bearing strawbale walls that do not use strawbale braced wall panels.

AS106.12.3 Roof bearing assembly. Roof bearing assemblies shall be of nominal 2-inch by 6-inch (51 mm by 152 mm) lumber with 15/32-inch (12 mm) plywood or OSB panels fastened with 8d nails at 6 inches (152 mm) o.c. in accordance with Items 1 through 6, or be of an *approved* engineered design.

1. Assembly shall be a box assembly on the top course of bales, with the panels horizontal.
2. Assembly shall be the width of the strawbale wall and shall comply with Section AS106.11.
3. Discontinuous lumber shall be spliced with a metal strap with a minimum 500 pound (2224 N) allowable wind or seismic load tension capacity. Where the wall line includes a braced wall panel the strap shall have not less than a 2000 pound (8896 N) capacity.
4. Panel joints shall be blocked.
5. Roof and ceiling framing shall be attached to the roof bearing assembly in accordance with Table R602.3(1) Items 2 and 6.
6. Where the roof bearing assembly spans wall openings it shall comply with Section AS106.12.3.1.

AS106.12.3.1 Roof bearing assembly spanning openings. Roof bearing assemblies that span openings in strawbale walls shall comply with the following at each opening:

1. Lumber on each side of the assembly shall be of the dimensions and quantity required to span each opening in accordance with Table R602.7(1).
2. The required lumber in the assembly shall be supported at each side of the opening by the number of jack studs required by Table R602.7(1), or shall extend beyond the opening on both sides a distance D, using the following formula:

$$D = S \times R/2 / (1-R)$$

where:

D = minimum distance (in feet) for required spanning lumber to extend beyond the opening

S = span in feet

R = B_L / B_C

B_L = design load on the wall (in pounds per lineal foot) in accordance with Sections R301.4 and

R301.6

B_c = allowable bearing capacity of the wall in accordance with Table AS106.12

AS106.12.5 Post-and-beam with strawbale infill. Post-and-beam with strawbale infill systems shall be in accordance with Items 1 through 6, or an *approved* engineered design.

1. Beams shall be of the dimensions and number of members in accordance with Table R602.7(1), where the space between posts equals the span in the table.
2. Beam ends shall bear over posts not less than 1 1/2 inches (38 mm) or be supported by a framing anchor in accordance with Table R602.7(1).
3. Discontinuous beam ends shall be spliced with a metal strap with not less than 1000 pound (4448 kg) wind or seismic load tension capacity. Where the wall line includes a braced wall panel, the strap shall have not less than a 4000 pound (17,793 kg) capacity.
4. Each post shall equal $NJ + 1$ in accordance with Table R602.7(1), where the space between posts equals the span in the table.
5. Posts shall be connected to the beam by an *approved* means.
6. Roof and ceiling framing shall be attached to the beam in accordance with Table R602.3(1) Items 2 and 6.

AS108.1 R-value. The unit *R*-value of a strawbale wall with bales laid flat is ~~R-1.3~~ per R-1.55 for each inch of bale thickness. The unit *R*-value of a strawbale wall with bales on-edge is ~~R-2~~ per R-1.85 for each inch of bale thickness.

AS108.2 Compliance with Section R302.10.1 Straw bales meet the requirements for insulation materials in Section R302.10.1 for flame spread index and smoke-developed index as tested in accordance with ASTM E84.

SECTION AS109 REFERENCED STANDARDS

ASTM

C 5—10	Standard Specification for Quicklime for Structural Purposes	AS104.4.6.1
C 109/C 109M—12	Standard Test Method for Compressive Strength of Hydraulic Cement Mortars	AS106.6.1
C 141/C 141M—09	Standard Specification for Hydrated Hydraulic Lime for Structural Purposes	AS104.4.6.1
C 206—03	Standard Specification for Finishing Hydrated Lime	AS104.4.6.1
C 926—12a	Standard Specification for Application of Portland Cement Based Plaster	AS104.4.7, AS104.4.8
C 1707—11	Standard Specification for Pozzolanic Hydraulic Lime for Structural Purposes	AS104.4.6.1
<u>E2392/E2392M-10</u>	<u>Standard Guide for Design of Earthen Wall Building Systems</u>	<u>AS104.4.3.2</u>

EN

459—2010	Part 1: Building Lime. Definitions, Specifications and Conformity Criteria; Part 2: Test Methods	AS104.4.6.1
----------	---	-------------

Reason: The proposed code changes in this proposal create new or revised requirements relative to the appendix as first approved for the 2015 IRC. These changes are based on further experience and additional input from prominent straw bale construction design and building professionals in different regions of the United States. Reasons for proposed changes per section are as follows:

AS102.1 Definitions:

A definition for CLAY SUBSOIL is added and the term is then used in subsections of Section AS104.4.3 and in the definition of CLAY SLIP. This brings clarity to this often misunderstood material used in many strawbale wall systems.

A definition for ON-END is added because bales are increasingly and successfully being used in this orientation in nonstructural straw bale walls for insulation and a substrate for plaster.

AS104.2 Purpose, and where required:

New language allows the face of a bale wall to remain unplastered when tight against dense-packed cellulose insulation in an adjacent framed wall. This satisfies the relevant purposes of restricting air movement for thermal performance and the potential spread of fire. This has been practiced successfully in permitted, inspected strawbale buildings regionally. An industry magazine article is posted at: <http://ecobuildnetwork.org/projects/straw-bale-code-supporting-documents>

AS104.4.3.2 Lath and mesh:

The existing section title and content are sufficiently addressed in Section AS104.4.2 Lath and mesh for plaster, and therefore are removed. The important subject clay subsoil suitability is absent from the current appendix. Therefore a new section title, "Clay subsoil requirements", and two tests from ASTM 2392-10 that are commonly used by clay plaster practitioners to determine the suitability of clay subsoil, are proposed.

AS105.3.1 Exterior sill plate flashing:

This new section requires flashing across plate to slab or foundation joints to prevent water intrusion at this location. This important requirement is currently absent from Appendix S.

Table AS105.4:

Wood framing is added as a method of out-of-plane resistance with an approved means of attachment of the bales to the framing. This method has been successfully utilized regionally for over 10 years for strawbale walls adjacent to or integrated with wood frame walls. Structural calculations justifying the particulars of the variables in the table are posted at: <http://ecobuildnetwork.org/projects/straw-bale-code-supporting-documents>

AS105.6.9 Separation of exterior plaster and foundation:

This new section requires a moisture barrier between a strawbale wall's exterior plaster and the foundation to prevent the wicking of moisture into the exterior plaster and potentially to the bales at this location. This important requirement is currently absent from Appendix S.

AS106.1 General:

The limitation of one-story is removed from this section and relocated to Section AS106.2.

AS106.2 Building limitations and requirements for use of strawbale *structural* walls:

This new section gives building limitations and requirements in the same format as Section 105.2 for non-structural walls. It gives clarity and corrals existing information for structural walls in scattered locations. In Item 4 it also clarifies that braced wall panel lengths are to be the greater value of those shown in Tables AS106.13.3(1) and AS106.13.3(2).

AS106.12.3 Roof bearing assembly:

This new section prescribes a roof bearing assembly for load-bearing strawbale walls. Details of this common member of a load-bearing strawbale wall are currently absent from Appendix S. Engineering analysis justifying the requirements in this section are posted at: <http://ecobuildnetwork.org/projects/straw-bale-code-supporting-documents>

AS106.12.3.1 Roof bearing assembly spanning openings:

IRC Table R602.10(1) for girders and headers is used to determine the size of lumber elements in the roof bearing assembly where it spans a wall opening. A formula is given to determine the required distance for the header element to extend beyond the wall opening where jack studs are not used. Engineering analysis justifying the requirements in this section are posted at: <http://ecobuildnetwork.org/projects/straw-bale-code-supporting-documents>

AS106.15 Post-and-beam with strawbale infill:

This new section prescribes a post-and-beam system with strawbale infill. Details of this common system are currently absent from Appendix S. IRC Table R602.10(1) for girders and headers is used to determine the beam size and the posts depending on the span and loading conditions. Engineering analysis justifying the requirements in this section are posted at: <http://ecobuildnetwork.org/projects/straw-bale-code-supporting-documents>

AS108.1 R-value:

The proposed changes in unit R-values for bales laid flat and bales on-edge are based on new data from thermal resistance tests conducted in Denmark (2004) and the U.K. (2012) along with tests at the Oak Ridge National Laboratory (ORNL) in Tennessee (1998). The ORNL tests were conducted in accordance with the guarded hot box protocol of ASTM C236, and the Danish and U.K. tests in accordance with its ISO equivalent, ISO 8990.

The current values in Section AS108.1 were based on the ORNL test and analysis by the California Energy Commission (CEC), which conservatively established the R-value for bales laid flat at R1.3 per inch from the ORNL test value of R1.45. Taking all three tests into account, the R-value for bales laid flat is adjusted upward to R1.55 and is adjusted downward to R1.85 for bales on-edge. The predominant orientation of straw in common bales continues to explain why the unit R-value varies with bale orientation.

Analysis of the data was performed by energy consultant Nehemiah Stone who was part of the team that conducted the CEC analysis in 1998. The current analysis as well as the reports from the Danish Urban and Building Research Institute and University of Bath (U.K.) tests are posted at: <http://ecobuildnetwork.org/projects/straw-bale-code-supporting-documents>

AS108.2 Compliance with Section R302.10.1:

This new section states compliance with the requirements of Section R302.10.1 and is necessary because building officials and design and building professionals are generally unaware of or would be unable to find the ASTM E84 test conducted in 2000 that demonstrated that straw bales meet these requirements. The test report is posted at: <http://ecobuildnetwork.org/projects/straw-bale-code-supporting-documents>

Bibliography: <http://ecobuildnetwork.org/projects/straw-bale-code-supporting-documents>

Cost Impact: Will not increase the cost of construction

The proposed code changes in this proposal are minor relative to the overall system of strawbale construction and therefore will have no cost impact when using this method of construction.

Report of Committee Action Hearings
--

Committee Action:

Approved as Submitted

Committee Reason: This proposal makes improvements to straw bale as recommended by the industry. The committee would like to see the wind speed calculations tweaked and the proper standards referenced for blown in cellulose insulation in the public comment period as discussed in testimony.

Assembly Action:

None

Final Action Results

RB368-16

AS

Code Change No: **RB369-16**

Original Proposal

Section: AS107.1

Proponent: Marcelo Hirschler, representing GBH International (gbhint@aol.com)

Revise as follows:

AS107.1 Fire-resistance rating. Strawbale walls shall not be considered to ~~be non-rated-exhibit a fire resistance rating~~, except for walls constructed in accordance with Section AS107.1.1 or AS107.1.2. Alternately, fire-resistance ratings of strawbale walls shall be determined in accordance with Section R302 of the *International Residential Code*.

Reason: Purely editorial: the correct terminology is to address fire resistance rating.

Cost Impact: Will not increase the cost of construction
Purely editorial

Report of Committee Action Hearings

Committee Action:

Approved as Submitted

Committee Reason: There are some improvements with the proposed language.

Assembly Action:

None

Final Action Results

RB369-16

AS

Code Change No: **RB370-16**

Original Proposal

Section: AS107.1.1, AS107.1.2

Proponent: Tim Earl, representing GBH International (tearl@gbhinternational.com)

Revise as follows:

AS107.1.1 One-hour rated clay plastered wall. One-hour fire-resistance-rated nonload-bearing clay plastered strawbale walls shall comply with all of the following:

1. Bales shall be laid flat or on-edge in a running bond.
2. Bales shall maintain thickness of not less than 18 inches (457 mm).
3. Bales shall have a minimum density of 7.5 pounds per cubic foot.
4. Gaps shall be stuffed with straw-clay.
5. Clay plaster on each side of the wall shall be not less than 1 inch (25 mm) thick and shall be composed of a mixture of 3 parts clay, 2 parts chopped straw and 6 parts sand, or an alternative approved clay plaster.
6. Plaster application shall be in accordance with Section AS104.4.3.3 for the number and thickness of coats.

AS107.1.2 Two-hour rated cement plastered wall. Two-hour fire-resistance-rated nonload-bearing cement plastered strawbale walls shall comply with all of the following:

1. Bales shall be laid flat or on-edge in a running bond.
2. Bales shall maintain a thickness of not less than 14 inches (356 mm).
3. Bales shall have a minimum density of 7.5 pounds per cubic foot.
4. Gaps shall be stuffed with straw-clay.
5. one (1)¹/₂-inch (38 mm) by 17-gage galvanized woven wire mesh shall be attached to wood members with 1¹/₂-inch (38 mm) staples at 6 inches (152 mm) on center. 9 gage U-pins with not less than 8-inch (203 mm) legs shall be installed at 18 inches (457 mm) on center to fasten the mesh to the bales.
6. Cement plaster on each side of the wall shall be not less than 1 inch (25 mm) thick.
7. Plaster application shall be in accordance with Section AS104.4.8 for the number and thickness of coats.

Reason: This appendix was added to the code last cycle. The fire test reports provided by the submitter stated that the bales tested had a density of 7.5 pcf. This section currently mandates a minimum bale density of 6.5 pcf. So, the appendix currently permits a 1-hour or 2-hour fire resistance rating for assemblies which have not demonstrated this level of performance in fire tests.

The ASTM E119 test involves measuring the temperature on the unexposed side of the specimen when it is exposed to heat from a furnace. A more dense bale will delay the temperature rise on the unexposed side and perform better in this test. As such, the fire test provided does not represent the worst case scenario, as it should.

Therefore, the 1-hour or 2-hour fire resistance rating should only be assigned to walls with bale density of at least 7.5 pcf, as no fire test data has been provided for bales of lesser density.

Cost Impact: Will increase the cost of construction

This proposal may increase the cost of construction if a user intended to build a 1-hour or 2-hour rated wall with bales of a density less than 7.5 pcf.

**Report of Committee Action
Hearings**

Committee Action:

Approved as Submitted

Committee Reason: This proposal clarifies the requirements of the code.

Assembly Action:

None

Final Action Results

RB370-16

AS

Code Change No: **RB371-16**

Original Proposal

Section: U103, U103.1, U103.2, U103.3, U103.4, U103.5, U103.5 (New), U103.6, U103.6 (New), U103.7, U103.8

Proponent: Kathleen Petrie, City of Seattle, Department of Construction and Inspections, representing City of Seattle, Department of Construction and Inspections (kathleen.petrie@seattle.gov)

Revise as follows:

U103.1 General. New detached one- and two-family dwellings, and multiple single-family dwellings (townhouses) with not less than 600 square feet (55.74 m²) of roof area oriented between ~~440~~90 degrees and 270 degrees of true north shall comply with sections U103.2 through ~~U103.8~~U103.10.

Exceptions:

1. New residential buildings with a permanently installed on-site renewable energy system.
2. A building ~~with a solar-ready zone where all areas of the roof that is shaded would otherwise meet the requirements of Section U103 are in full or partial shade~~ for more than 70 percent of daylight hours annually.

U103.2 Construction document requirements for solar ready zone. Construction documents shall indicate the solar- ready *zone*.

U103.3 Solar-ready zone area. The total solar-ready *zone* area shall be not less than 300 square feet (27.87 m²) exclusive of mandatory access or set back areas as required by the *International Fire Code*. New multiple single-family dwellings (townhouses) three stories or less in height above grade plane and with a total floor area less than or equal to 2,000 square feet (185.8 m²) per dwelling shall have a solar-ready *zone* area of not less than 150 square feet (13.94 m²). The solar-ready *zone* shall be composed of areas not less than 5 feet (1.52 m) in width and not less than 80 square feet (7.44 m²) exclusive of access or set back areas as required by the *International Fire Code*.

U103.4 Obstructions. Solar-ready *zones* shall be free from obstructions, including but not limited to vents, chimneys, and roof-mounted equipment.

Add new text as follows:

U103.5 Shading The solar-ready zone shall be set back from any existing or new permanently affixed object on the building or site that is located south, east, or west of the solar zone a distance at least two times the object's height above the nearest point on the roof surface. Such objects include, but are not limited to, taller portions of the building itself, parapets, chimneys, antennas, signage, rooftop equipment, trees, and roof plantings.

U103.6 Capped roof penetration sleeve A capped roof penetration sleeve shall be provided adjacent to a solar-ready zone located on a roof slope of 2:12 or less. The capped roof penetration sleeve shall be sized to accommodate the future photovoltaic system conduit, but shall have an inside diameter of not less than 1 ¼ inches.

Revise as follows:

~~U103.5~~U103.7 **Roof load documentation.** *No change to text.*

~~U403.6~~ ~~U103.8~~ **Interconnection pathway.** *No change to text.*

~~U403.7~~ ~~U103.9~~ **Electrical service reserved space.** *No change to text.*

~~U403.8~~ ~~U103.10~~ **Construction documentation certificate.** *No change to text.*

Reason: The modifications proposed are designed to provide clarification and strengthen the existing Solar-ready Appendix U.

In Section U103.1, the roof area orientation has been modified from 110 degrees to 90 in order to maximize the roof slopes that maximize solar technology effectiveness. For similar reasons, Section U103.3 now precludes any portion of the solar zone from being located on a roof slope greater than 2:12 that faces within 45 degrees of true north.

New Section U103.5 clarifies the term "shading" used in Section U103.1, Exception #2, by clarifying how far the designated solar-ready zone should be set back from permanently affixed objects.

If necessary for the system, it is considerably cheaper to provide a path for future wiring from the solar panel to the meter at the time of new construction than after, so roofs with a slope of 2:12 or less must provide a pipe sleeve penetration. There are other design options for roofs with greater slopes, so a penetration is not necessary.

Cost Impact: Will increase the cost of construction

Only in roofs with a slope of 2:12 or less will this proposal increase the cost of construction by \$100. In all other projects it will not increase the cost of construction.

Report of Committee Action Hearings
--

Committee Action:

Approved as Submitted

Committee Reason: The new language takes shading into account, clarifies the code and adds flexibility for builders.

Assembly Action:

None

Final Action Results

RB371-16

AS

Code Change No: RB376-16

Original Proposal

Section: R703.8.4

Proponent: Charles Clark, Jr, representing Masonry Alliance for Codes and Standards (Brick Industry Association) (cclark@bia.org)

Revise as follows:

**TABLE R703.8.4
TIE ATTACHMENT AND AIRSPACE REQUIREMENTS**

BACKING AND TIE	MINIMUM TIE	MINIMUM TIE FASTENER ^a	AIRSPACE ^c	
Wood stud backing with corrugated sheet metal	22 U.S. gage (0.0299 in.) x ⁷ / ₈ in. wide	8d common nail ^b (2 ¹ / ₂ in. x 0.131 in.)	Nominal 1 in. between sheathing and veneer	
Wood stud backing with metal strand wire	W1.7 (No. 9 U.S. gage; 0.148 in.) with hook embedded in mortar joint	8d common nail ^b (2 ¹ / ₂ in. x 0.131 in.)	Minimum nominal 1 in. between sheathing and veneer	Maximum 4 ¹ / ₂ in. between backing and veneer
Cold-formed steel stud backing with adjustable metal strand wire	W1.7 (No. 9 U.S. gage; 0.148 in.) with hook embedded in mortar joint	No. 10 screw extending through the steel framing a minimum of three exposed threads	Minimum nominal 1 in. between sheathing and veneer	Maximum 4 ¹ / ₂ in. between backing and veneer

For SI: 1 inch = 25.4 mm.

a. In Seismic Design Category D₀, D₁ or D₂, the minimum tie fastener shall be an 8d ring-shank nail (2¹/₂ in. x 0.131 in.) or a No. 10 screw extending through the steel framing a minimum of three exposed threads.

b. All fasteners shall have rust-inhibitive coating suitable for the installation in which they are being used, or be manufactured from material not susceptible to corrosion.

c. An airspace that provides drainage shall be permitted to contain mortar from construction.

Reason: This code change is intended to acknowledge that the airspace behind a well-constructed, code-compliant brick veneer will never be completely devoid of mortar. No matter how careful an experienced, seasoned mason is in constructing the veneer, some small amount of mortar from construction will be found in the airspace. Such an airspace, along with code-mandated water-resistant barrier, flashing and weep holes, has long provided a proven drainage system to keep the backing and interior dry and to direct water to the exterior. This is evidenced by the many brick veneer buildings that have performed well and have not experienced any interior water issues even though they undoubtedly have some mortar in their airspace.

Historically, architects, engineers, building code officials and building owners have readily-recognized the difference between a brick veneer with a code-compliant airspace and one that was not. However, in the litigious society that we now find ourselves living in, the airspaces of some brick veneer buildings that previously would have been deemed acceptable are now called into question well after the buildings have been occupied even though the buildings are not experiencing any water damage or drainage issues associated with the brick veneer wall system. This clarification to the code is proposed to acknowledge that the airspace may contain some mortar from construction as long as it provides drainage.

Cost Impact: Will not increase the cost of construction

This code change proposal is a clarification of the existing code language. It is intended to acknowledge and reflect more closely the common practice used in the field for the construction of anchored stone and masonry veneer construction. As such, there should be no cost impact.

**Report of Committee Action
Hearings**

Committee Action:

Approved as Submitted

Committee Reason: The committee approved this proposal based on the proponents published reason statement.

Assembly Action:

None

Final Action Results

RB376-16

AS

Code Change No: **RM1-15**

Original Proposal

Section: M1305.1.4.2

Proponent: Guy McMann, Jefferson County Colorado, representing Colorado Association of Plumbing and Mechanical Officials (CAPMO) (gmcman@jeffco.us)

Delete and substitute as follows:

M1305.1.4.2 Excavations. Pit locations ~~Excavations for appliance installations shall extend to a depth of 6 inches (152 mm) below the appliance and 12 inches (305 mm) on all sides, except that the control side shall have a clearance of 30 inches (762 mm).~~

Appliances installed in pits or excavations shall not come in direct contact with the surrounding soil and shall be installed not less than 6 inches (152 mm) above the pit floor. The sides of the pit or excavation shall be held back not less than 12 inches (305 mm) from the appliance. Where the depth exceeds 12 inches (305 mm) below adjoining grade, the walls of the pit or excavation shall be lined with concrete or masonry. Such concrete or masonry shall extend not less than 4 inches (102 mm) above adjoining grade and shall have sufficient lateral load-bearing capacity to resist collapse. Excavation on the control side of the appliance shall extend horizontally not less than 30 inches (762 mm). The appliance shall be protected from flooding in an *approved* manner.

Reason: The language in the IMC and IFGC is much more complete and concise. This modification completes this section and has all the information necessary for a code compliant installation and makes it consistent with the other codes

Cost Impact: Will not increase the cost of construction
This proposal is strictly editorial in nature and will not cause an increase in cost.

Report of Committee Action Hearings

Committee Action:

Approved as Modified

Modify as follows:

M1305.1.4.2 Pit locations. Appliances installed in pits or excavations shall not come in direct contact with the surrounding soil and shall be installed not less than ~~6-3~~ inches (152 mm) above the pit floor. The sides of the pit or excavation shall be held back not less than 12 inches (305 mm) from the appliance. Where the depth exceeds 12 inches (305 mm) below adjoining grade, the walls of the pit or excavation shall be lined with concrete or masonry. Such concrete or masonry shall extend not less than 4 inches (102 mm) above adjoining grade and shall have sufficient lateral load-bearing capacity to resist collapse. Excavation on the control side of the appliance shall extend horizontally not less than 30 inches (762 mm). The appliance shall be protected from flooding in an approved manner.

Committee Reason: Approval was based on the proponent's published reason statements. The modification changes an archaic 6 inch dimension to the more commonly required 3 inch dimension.

Assembly Action:

None

Final Action Results

RM1-15

AM

Code Change No: **RM3-15**

Original Proposal

Section: M1401.3

Proponent: Luis Escobar, representing Air Conditioning Contractors of America (luis.escobar@acca.org)

Revise as follows:

M1401.3 Equipment and appliance sizing. Heating and cooling *equipment and appliances* shall be sized in accordance with ACCA Manual S or other approved sizing methodologies based on building loads calculated in accordance with ACCA Manual J or other *approved* heating and cooling calculation methodologies.

~~**Exception:** Heating and cooling equipment and appliance sizing shall not be limited to the capacities determined in accordance with Manual S where either of the following conditions applies:~~

- ~~1. The specified equipment or appliance utilizes multistage technology or variable refrigerant flow technology and the loads calculated in accordance with the approved heating and cooling calculation methodology are within the range of the manufacturer's published capacities for that equipment or appliance.~~
- ~~2. The specified equipment or appliance manufacturer's published capacities cannot satisfy both the total and sensible heat gains calculated in accordance with the approved heating and cooling calculation methodology and the next larger standard size unit is specified.~~

Reason: The exceptions in the 2015 codes were initially introduced because it was not certain that Manual S would complete full revision prior to the 2015 code's publication. However, ACCA Manual S completed the ANSI consensus revision process in 2014 and is referenced in the 2015 code. This creates a severe contradiction between the IRC and the national consensus standard it references.

The Manual S revision committee that developed the sizing procedures and oversize limits included the manufacturers of multi-stage and variable refrigerant flow (VRF) equipment. Those limits were revised through the public review process and now allow a greater range of equipment to be installed for multi-stage and VRF applications. The published Manual S fully covers the proper procedures for multi-stage and VRF technology agreed upon by designers, manufacturers, and energy advocates.

A study published in September 2014 by the National Institute of Standards and Technology, entitled "Sensitivity Analysis of Installation Faults on Heat Pump Performance", found that the energy penalty for over-sizing HVAC equipment could lead to as much as 20% greater energy use in warm climates. Manual S-2014 however allows a new method of oversizing multi-stage and VRF equipment in cold climates to get the necessary heating performance, while still maintaining appropriate sizing limits for warm climates. BUT the current exceptions apply across the board and will lead to unjustifiable oversizing that cost energy and money.

Bibliography: [Sensitivity Analysis of Installation Faults on Heat Pump Performance][NIST Technical Note 1848][Domanski, Henderson, Payne][2014][www.acca.org/standards/quality][Understanding ACCA Manual S][ACCA Special Presentation][Luis Escobar][2014][available upon request luis.escobar@acca.org][Residential Equipment Selection][ANSI/ACCA 3 Manual S - 2014][ACCA][2014][www.acca.org/standards/codes]

Cost Impact: Will not increase the cost of construction

See energy consumption results from NIST Study, specifically single fault: equipment sizing. Energy use can increase by up to 24% if oversizing is the only installation fault. The effects are greater with additional installation faults (duct leakage, indoor coil airflow, refrigerant under/over charging, etc.).

Report of Committee Action Hearings

Committee Action:

Approved as Submitted

Committee Reason: Approval was based on the proponent's published reason statements.

Assembly Action:

None

Final Action Results

RM3-15

AS

Code Change No: **RM5-15**

Original Proposal

Section: M1411.6.1 (New)

Proponent: Howard Ahern, representing Airex Mfg. (howard@plumberex.com)

Add new text as follows:

M1411.6.1 Refrigerant line insulation protection Refrigerant Piping insulation exposed to weather shall be protected from damage, including that caused by sunlight, moisture, equipment maintenance and wind. Adhesive tape shall not be considered as a means of protection.

Reason: This code change clarifies that the Refrigerant vapor (suction) line insulation complying with M1411.6 needs to be protected when it is exposed outdoors. There has been confusion from Builders, inspectors and contractors that manufactures marking U.V. on the pipe insulation was all that was needed to protect outdoor Refrigerant vapor (suction) line insulation. The majority of Pipe Insulation Manufacturers for Refrigerant vapor (suction) line insulation already have stated in their technical papers or installation instructions that when using their insulation outdoors it must be protected from UV, weather and other damage such as rodents and birds and that they offer only a limited UV resistance. No elastomeric foam is truly UV resistant.

The damage can also be caused by not only U.V, moisture, wind and damage from equipment maintenance but also oxidation. All these factors will permanently damage the insulations external surface permeability and seriously impact the insulation thermal conductivity which will impact the heating or cooling systems efficiency and resulting in higher electrical cost as the compressor must work harder to compensate for the temperature difference which can lead to a shorter life span of the equipment.

Adhesives break down due to bacteria and moisture, removal of Adhesives tape would destroy the external surface permeability of the insulation required in M1411.6

Cost Impact: Will not increase the cost of construction

This code change will not increase cost of construction in jurisdictions that have adopted the 2102 or the 2015 IECC. Most jurisdictions by 2018 should have adopted one of the IECC codes. This would only be a cost increase to jurisdictions that have not adopted the 2102 or the 2015 IECC. The majority of pipe insulation manufactures already state in their technical papers or instructions that when using their insulation outdoors it must be protected from weather.

Report of Committee Action Hearings

Committee Action:

Approved as Modified

Modify proposal as follows:

M1411.6.1 Refrigerant line insulation protection. Refrigerant piping insulation shall be protected in accordance with Section N1103.4.1. exposed to weather shall be protected from damage, including that caused by sunlight, moisture, equipment maintenance and wind. Adhesive tape shall not be considered as a means of protection.

Committee Reason: Approval was based on the proponent's published reason statements. The modification provides guidance on the protection required and refers back to current code text to avoid redundant text. The committee agreed with the proponent's published reason statement.

Assembly Action:

None

Final Action Results

RM5-15

AM

Code Change No: RM11-15

Original Proposal

Section: M1502.3.1 (New)

Proponent: Julius Ballanco, JB Engineering and Code Consulting, P.C., representing In-O-Vate Technologies (JBENGINEER@aol.com)

Add new text as follows:

M1502.3.1 Exhaust termination outlet and passageway size. The passageway of dryer exhaust duct terminals shall be undiminished in size and shall provide an open area of not less than 12.5 square inches (8,065 sq mm).

Reason: The allowable (calculated) length of the dryer exhaust duct is based on an open (non-restrictive) exhaust terminal. Some exhaust terminals increase resistance due to their inherent design characteristics (path and final opening size). This results in the dryer exhaust duct having to be reduced in length. However, there is no allowance for a reduction in length for a highly resistant vent cap. Short of requiring testing standards for every vent termination, the code must require a minimum open area of 12.5 sq. inches which equates to a 4" round duct. The code is very sensitive and detailed as it relates to 90 degree elbows and their respective friction loss but does not prohibit or penalize for termination hoods that grossly create back pressure, reducing the efficiency of the dryer.

The dimension used for the opening in the interior area of the 4 inches duct is rounded to an even number (12.5"). By maintaining the same opening area throughout the vent terminal, the friction resistance in vent caps can be greatly reduced.

Video Links:

www.youtube.com/watch?v=5KnRp3eXNbk
<http://youtu.be/ZL2zV1-Gjdl?t=50s>



Cost Impact: Will increase the cost of construction
The cost of the vent terminal may be higher.

**Report of Committee Action
Hearings**

Committee Action:

Approved as Submitted

Committee Reason: Approval was based on the proponent's published reason statements. The proposal provides criteria for homemade terminals.

Assembly Action:

None

Final Action Results

RM11-15

AS

Code Change No: RM12-15

Original Proposal

Section: M1502.4.2

Proponent: Julius Ballanco, JB Engineering and Code Consulting, P.C., representing In-O-Vate Technologies (JBENGINEER@aol.com)

Revise as follows:

M1502.4.2 Duct installation. Exhaust ducts shall be supported at intervals not to exceed 12 feet (3658 mm) and shall be secured in place. The insert end of the duct shall extend into the adjoining duct or fitting in the direction of airflow. Exhaust duct joints shall be sealed in accordance with Section M1601.4.1 and shall be mechanically fastened. Ducts shall not be joined with screws or similar fasteners that protrude more than $\frac{1}{8}$ inch (3.2 mm) into the inside of the duct. Where dryer exhaust ducts are enclosed in wall or ceiling cavities, such cavities shall have a least dimension allow the installation of not less than 4.25 inches (108 mm). Round ducts shall not be deformed. the duct without deformation.

Reason: The dryer exhaust duct must remain round in shape to reduce friction loss in the duct system. The length of the duct and termination are based on friction loss for round duct, not oval duct. The length of the dryer exhaust duct would have to be reduced if the 4 inch duct was oval in shape. In addition to the reduction in efficiency, the oval pipe creates a difficult connection for the consumer to make to the dryer exhaust transition hose.

A 1 inch furring strip (1x2) can be added to a 2 x 4 stud providing the 4.25 inches of space. In most cases, this "mechanical" wall is busy with other trades (plumbing drainage and vent stacks, gas piping, electric service, laundry services and water piping). A 4.25 inch space will benefit all of the trades working within that space. The minimum space required to keep the dryer exhaust duct round is 4.125 inches. This dimension could also be referenced here, however, most contractors







Examples of "mechanical walls" showing the abundance of utilities in this wall, demonstrating the need to provide more than 3.5"

Cost Impact: Will increase the cost of construction
There is an added cost for furring strips on a 2 x 4 wall.

Report of Committee Action Hearings
--

Committee Action:**Approved as Modified****Modify proposal as follows:**

M1502.4.2 Duct installation. Exhaust ducts shall be supported at intervals not to exceed 12 feet (3658 mm) and shall be secured in place. The insert end of the duct shall extend into the adjoining duct or fitting in the direction of airflow. Exhaust duct joints shall be sealed in accordance with Section M1601.4.1 and shall be mechanically fastened. Ducts shall not be joined with screws or similar fasteners that protrude more than 1 /8 inch (3.2 mm) into the inside of the duct. Where dryer exhaust ducts are enclosed in wall or ceiling cavities, such cavities shall have a least dimension allow the installation of not less than 4.25 inches (108 mm). Round ducts shall not be deformed. ~~the duct without deformation.~~

Committee Reason: Approval was based on the proponent's published reason statements. The modification deletes the specification in inches to allow all manufacturer's products to be installed in 2 x 6 walls and clearly states the requirement to have ample room for round ducts. Duct deformation impedes air flow.

Assembly Action:**None**

Final Action Results

RM12-15**AM**

Code Change No: **RM14-15**

Original Proposal

Section: M1503, M1503.1, M1503.1 (New), M1503.2, M1503.2 (New), M1503.2.1 (New), M1505, M1505.1

Proponent: Jonathan Roberts, UL LLC, representing UL LLC (jonathan.roberts@ul.com)

Revise as follows:

SECTION M1503 RANGE HOODS DOMESTIC COOKING EXHAUST EQUIPMENT

Add new text as follows:

M1503.1 General. Domestic cooking exhaust equipment shall comply with the requirements of this section.

M1503.2 Domestic cooking exhaust. Where domestic cooking exhaust equipment is provided it shall comply with one of the following:

1. Overhead range hoods and downdraft exhaust equipment not integral with the cooking appliance shall be listed and labeled in accordance with UL 507.
2. Domestic cooking appliances with integral downdraft exhaust equipment shall be listed and labeled in accordance with UL 858 or ANSI Z21.1.
3. Microwave ovens with integral exhaust for installation over the cooking surface shall be listed and labeled in accordance with UL 923.

M1503.2.1 Open top broiler exhaust. Domestic open-top broiler units shall be provided with a metal exhaust hood, having a thickness of not less than 0.0157-inch (0.3950 mm) (No. 28 gage). Such hood shall be installed with a clearance of not less than 1/4 inch (6.4 mm) between the hood and the underside of combustible material and cabinets. A clearance of not less than 24 inches (610 mm) shall be maintained between the cooking surface and combustible material and cabinets. The hood width shall be not less than the width of the broiler unit and shall extend over the entire unit.

Exception: Broiler units that incorporate an integral exhaust system, and that are listed and labeled for use without an exhaust hood, shall not be required to have an exhaust hood.

Revise as follows:

M1503.4~~M1503.3~~ **General Exhaust discharge.** Range hoods Domestic cooking exhaust equipment shall discharge to the outdoors through a duct. The duct serving the hood shall have a smooth interior surface, shall be air tight, shall be equipped with a back-draft damper and shall be independent of all other exhaust systems. Ducts serving range hoods domestic cooking exhaust equipment shall not terminate in an attic or crawl space or areas inside the building.

Exception: Where installed in accordance with the manufacturer's instructions, and where mechanical or natural *ventilation* is otherwise provided, *listed* and *labeled* ductless range hoods shall not be required to discharge to the outdoors.

M1503.2M1503.4 Duct material. Ducts serving ~~range hoods~~ domestic cooking exhaust equipment shall be constructed of galvanized steel, stainless steel or copper.

Exception: Ducts for domestic kitchen cooking *appliances* equipped with down-draft exhaust systems shall be permitted to be constructed of schedule 40 PVC pipe and fittings provided that the installation complies with all of the following:

1. The duct is installed under a concrete slab poured on grade.
2. The underfloor trench in which the duct is installed is completely backfilled with sand or gravel.
3. The PVC duct extends not more than 1 inch (25 mm) above the indoor concrete floor surface.
4. The PVC duct extends not more than 1 inch (25 mm) above grade *outside of the building*.
5. The PVC ducts are solvent cemented.

Delete without substitution:

~~SECTION M1505~~ ~~OVERHEAD EXHAUST HOODS~~

~~**M1505.1 General.** Domestic open-top broiler units shall have a metal exhaust hood, having a minimum thickness of 0.0157 inch (0.3950 mm) (No. 28 gage) with $\pm \frac{1}{16}$ inch (6.4 mm) clearance between the hood and the underside of combustible material or cabinets. A clearance of not less than 24 inches (610 mm) shall be maintained between the cooking surface and the combustible material or cabinet. The hood shall be not less than the width of the broiler unit, extend over the entire unit, discharge to the outdoors and be equipped with a backdraft damper or other means to control infiltration/exfiltration when not in operation. Broiler units incorporating an integral exhaust system, and *listed* and *labeled* for use without an exhaust hood, need not have an exhaust hood.~~

Reason: This proposal accomplishes the following:

1. Changes the name of Section M1503 from Range Hoods to Domestic Cooking Exhaust Equipment, which more accurately reflects the duct, makeup air, and exhaust air requirements in the section.
2. Adds a charging paragraph for the Section to M1503.1.
3. Describes the listing standards used to investigate the various types of exhaust equipment in Section M1503.2.
4. Relocates Section M1505.1 for open top broilers to section M1503.2.1.
5. Makes editorial revisions for clarity.

Cost Impact: Will not increase the cost of construction
It is primarily editorial in nature.

Report of Committee Action Hearings

Committee Action:

Approved as Modified

Modify as follows:

M1503.3 Exhaust discharge. Domestic cooking exhaust equipment shall discharge to the outdoors through a duct. The duct shall have a smooth interior surface, shall be air tight, shall be equipped with a back-draft damper and shall be independent of all other exhaust systems. Ducts serving ~~range hoods~~ domestic cooking exhaust equipment shall not terminate in an attic or crawl space or areas inside the building.

Exception: Where installed in accordance with the manufacturer's instructions, and where mechanical or natural ventilation is otherwise provided, listed and labeled ductless range hoods shall not be required to discharge to the outdoors.

Committee Reason: Approval is based on the proponent's published reason statements. The proposal is a logical reorganization of text. The modification provides consistency within the proposal regarding terminology.

Assembly Action:

None

Public Comments

Public Comment 1:

Julius Ballanco, JB Engineering and Code Consulting, P.C., representing Self (JBENGINEER@aol.com) requests Approve as Modified by this Public Comment.

Modify as follows:

M1503.2 Domestic cooking exhaust. Where domestic cooking exhaust equipment is provided it shall comply with one of the following:

1. ~~Overhead~~The fan for overhead range hoods and downdraft exhaust equipment not integral with the cooking appliance shall be listed and labeled in accordance with UL 507.
2. Overhead range hoods and downdraft exhaust equipment with intergral fans shall compy with UL 507.
3. Domestic cooking appliances with integral downdraft exhaust equipment shall be listed and labeled in accordance with UL 858 or ANSI Z21.1.
4. Microwave ovens with integral exhaust for installation over the cooking surface shall be listed and labeled in accordance with UL 923.
- 5.

Commenter's Reason: This change as originally proposed exceeds the scope of UL 507. UL 507 is a standard for fans and blowers, not range hoods. Included in the scope of the standard are overhead range hoods and downdraft exhaust equipment that have integral hoods. UL 507 does not regulate stand-alone range hoods that do not have an integral fan.

These prefabricated range hoods have served the industry successfully for many years. There is no justification for removing a viable range hood. If the code change is approved as proposed, one could only install a range hood that has an integral fan. That would be overly restrictive.

The modification corrects the mistake with the original submittal. UL 507 regulates all fans used for overhead range hoods and downdraft exhaust equipment. It also addresses range hoods and downdraft exhaust equipment with integral fans.

UL 507 does not regulate range hoods, whether prefabricated or field made. Hence, it is inappropriate to reference the standard for this application.

If this modification is not accepted, the change must be denied since the reference to UL 507 exceeds the scope of the standard. This is a violation of ICC policy.

Final Action Results

RM14-15
AMPC1

Code Change No: **RM15-15**

Original Proposal

Section: M1503.4, M1503.4.1, M1503.4.2 (New)

Proponent: Mike Moore, Newport Ventures, representing Broan-NuTone, representing Newport Ventures (mmoore@newportventures.net)

Revise as follows:

M1503.4 Makeup air required. ~~Exhaust hood systems~~ Where one or more gas-, liquid-, or solid-fuel-burning appliance that is neither direct-vent nor uses a mechanical draft venting system is located within a dwelling unit's air barrier, each exhaust system capable of exhausting in excess of 400 cubic feet per minute (0.19 m³/s) shall be mechanically or ~~naturally passively~~ provided with makeup air at a rate approximately equal to the exhaust air rate. Such makeup air systems shall be equipped with not less than one damper complying with Section M1503.4.2. ~~Each damper shall~~

Exception: ~~Makeup air is not required for exhaust systems installed for the exclusive purpose of space cooling and intended to be a gravity damper operated only when windows or an electrically operated damper that automatically opens when the exhaust system operates. Dampers shall be accessible for inspection, service, repair and replacement without removing permanent construction or any other ducts not connected to the damper being inspected, serviced, repaired or replaced air inlets are open.~~

M1503.4.1 Location. Kitchen exhaust makeup air shall be discharged into the same room in which the exhaust system is located or into rooms or *duct systems* that communicate through one or more permanent openings with the room in which such exhaust system is located. Such permanent openings shall have a net cross-sectional area not less than the required area of the makeup air supply openings.

Add new text as follows:

M1503.4.2 Makeup air dampers Where makeup air is required by Section M1503.4, makeup air dampers shall comply with this section. Each damper shall be a gravity damper or an electrically operated damper that automatically opens when the exhaust system operates. Dampers shall be accessible for inspection, service, repair and replacement without removing permanent construction or any other ducts not connected to the damper being inspected, serviced, repaired or replaced. Gravity or barometric dampers shall not be used in passive makeup air systems except where the dampers are rated to provide the design makeup airflow at a pressure differential of 0.01 in. w.c. (3 Pa) or less.

Reason: Backdrafting of combustion appliances typically presents the greatest danger associated with depressurizing a space. Field tests have confirmed that naturally vented combustion appliances (i.e., those that are not mechanically vented or direct-vent) are the most susceptible to depressurization, and measures should be taken to provide makeup air (MUA) for large exhaust appliances when such appliances are located within the dwelling unit's air barrier. ASHRAE 62.2, the consensus standard for Ventilation and Acceptable Indoor Air Quality in residential dwelling units, does not require MUA when combustion appliances are mechanically vented or are direct-vent. The ASHRAE 62.2 committee recently reviewed the 62.2 section requiring MUA, and the general consensus (no vote taken) was a reaffirmation that the MUA requirement should not apply to mechanically vented or direct-vent combustion appliances, due to lack of data to substantiate their susceptibility to backdrafting.

This proposal would relax the MUA requirement in the IRC by aligning it more closely with ASHRAE 62.2. Similar changes have been made to this section in Florida's and Virginia's adoptions of the IRC.

The proposal introduces a new section to address MUA dampers specifically, moving the text from M1503.4 to M1503.4.2 and introducing one new requirement for gravity or barometric dampers. It makes no sense to design a system to provide MUA if the damper does not open before the combustion appliance starts spilling. So, the new requirement is intended to ensure that when MUA is required, any gravity or barometric damper used to provide MUA shall engage at the pressure differential above which naturally drafted combustion appliances can be expected to backdraft (3 Pa, based on an acceptable 5%-20% failure rate across all

outdoor conditions)'. This proposed requirement only applies to gravity or barometric dampers in "passive" MUA systems, which are those that provide MUA without the assistance of a fan. Gravity or barometric dampers in "active" MUA systems are excluded from this requirement because we assume that the fan will create a sufficient pressure differential to open the damper.

A companion proposal has been submitted to the IMC.

Bibliography:

1. Bohac, D., et al. (2002). Ventilation and Depressurization Information for Houses Undergoing Remodeling. Accessed on Dec 5, 2014 at: <http://www.mncee.org/getattachment/eedb1afc-f50e-4833-b450-d52233f58ce0/>.

Cost Impact: Will not increase the cost of construction

This proposal is expected to reduce construction costs by reducing the number of scenarios requiring makeup air for kitchen exhaust.

**Report of Committee Action
Hearings**

Committee Action:

Approved as Submitted

Committee Reason: Approval was based on the proponent's published reason statements.

Assembly Action:

None

Final Action Results

RM15-15

AS

Code Change No: RM16-15

Original Proposal

Section: M1503.4

Proponent: Janine Snyder, City of Thornton, Colorado, representing Colorado Association of Plumbing & Mechanical Officials (CAPMO) (Janine.Snyder@cityofthornton.net)

Revise as follows:

M1503.4 Makeup air required. Exhaust-hood systems capable of exhausting in excess of 400 cubic feet per minute (0.19 m³/s) shall be mechanically or naturally provided with makeup air at a rate approximately equal to the exhaust air rate. Such makeup air systems shall be equipped with not less than one damper. Each damper shall be a gravity damper or an electrically operated damper that automatically opens when the exhaust system operates. Dampers shall be accessible for inspection, service, repair and replacement without removing permanent construction or any other ducts not connected to the damper being inspected, serviced, repaired or replaced.

Reason: The proposed change allows the code to capture down draft systems as well and not just apply to hoods.

Cost Impact: Will not increase the cost of construction
This will allow consistency with all exhaust systems.

Report of Committee Action Hearings
--

Committee Action:**Approved as Submitted**

Committee Reason: Approval was based on the proponent's published reason statements.

Assembly Action:**None**

Final Action Results

RM16-15**AS**

Code Change No: **RM19-15**

Original Proposal

Section: M1504.1, M1901.1, M1901.2

Proponent: Jonathan Roberts, UL LLC, representing UL LLC (jonathan.roberts@ul.com)

Delete without substitution:

~~**M1504.1 Installation of a microwave oven over a cooking appliance.** The installation of a *listed* and *labeled* cooking appliance or microwave oven over a *listed* and *labeled* cooking appliance shall conform to the terms of the upper *appliance's listing and label* and the manufacturer's installation instructions. The microwave oven shall conform to UL 923.~~

Revise as follows:

M1901.1 Clearances. Freestanding or built-in ranges shall have a vertical clearance above the cooking top of not less than 30 inches (762 mm) to unprotected combustible material. Reduced clearances are permitted in accordance with the *listing and labeling* of the range hoods or ~~*appliances*~~. ~~The installation of a *listed* and *labeled* cooking appliance or microwave oven over a *listed* and *labeled* cooking appliance shall be in accordance with Section M1504.1 integral exhaust.~~ The clearances for a domestic open-top broiler unit shall be in accordance with Section M1505.1.

M1901.2 Cooking appliances. Cooking *appliances* shall be *listed* and *labeled* for household use and shall be installed in accordance with the manufacturer's instructions. The installation shall not interfere with *combustion air* or access for operation and servicing. Electric cooking appliances shall comply with UL 1026 or UL 858. Solid-fuel-fired fireplace stoves shall comply with UL 737. Microwave ovens shall comply with UL 923.

Reason: This proposal clarifies installation criteria for microwave ovens with integral exhaust fans that are installed above cooking surfaces. It does this as follows:

1. Deletes Section M1504.1. Those requirements primarily deal with clearances, which is covered by Section M1901.1
2. Section M1901.1 was revised to clarify that reduced clearances to combustible material can be done in accordance with the listing and labeling of the microwave oven with integral exhaust.
3. The reference to microwave ovens complying with UL 923 was moved from deleted Section M1504.1 to Section M1901.2.

Cost Impact: Will not increase the cost of construction
Editorial changes only.

Report of Committee Action Hearings

Committee Action:

Approved as Submitted

Committee Reason: Approval was based on the proponent's published reason statements.

Assembly Action:

None

Final Action Results

RM19-15

AS

Code Change No: **RM21-15**

Original Proposal

Section: M1506.3

Proponent: Janine Snyder, representing Plumbing, Mechanical, and Fuel Gas Code Action Committee (PMGCAC@iccsafe.org)

Delete without substitution:

M1506.3 Exhaust openings. ~~Air exhaust openings shall terminate not less than 3 feet (914 mm) from property lines; 3 feet (914 mm) from operable and nonoperable openings into the building and 10 feet (3048 mm) from mechanical air intakes except where the opening is located 3 feet (914 mm) above the air intake. Openings shall comply with Sections R303.5.2 and R303.6.~~

Air exhaust openings shall terminate as follows:

1. Not less than 3 feet (914 mm) from property lines.
2. Not less than 3 feet (914 mm) from gravity air intake openings, operable windows and doors..
3. Not less than 10 feet (3048 mm) from mechanical air intakes openings except where the exhaust opening is located not less than 3 feet (914 mm) above the air intake opening. Openings shall comply with Sections R303.5.2 and R303.6.

Reason: This section has been misinterpreted because of its poor language and structure. It reads much better in a list format and the necessary clarifiers "not less than" were added where the code appeared to be requiring an exact distance of 3 or 10 feet. The terms "operable and nonoperable openings" are ambiguous because they could be referring to windows that don't open (inoperable) or grilles and louvers that have no means of closure. The intent, of course, is simply to regulate the distance to air intake openings, doors and operable windows. A fixed glass panel can be viewed as an opening, but there is no reason to limit the distance to an exhaust opening from a fixed glass panel. The last requirement relative to mechanical air intakes confused the words "opening" and "intakes," both of which are openings. The revised text cleans up this section with no change in intent.

This proposal is submitted by the ICC Plumbing, Mechanical and Fuel Gas Code Action Committee (PMGCAC) The PMGCAC was established by the ICC Board of Directors to pursue opportunities to improve and enhance assigned International Codes or portions thereof. This includes both the technical aspects of the codes and the code content in terms of scope and application of referenced standards. The PMGCAC has held one open meeting and multiple conference calls which included members of the PMGCAC. Interested parties also participated in all conference calls to discuss and debate the proposed changes.

Cost Impact: Will not increase the cost of construction

This proposal will not increase the cost of construction because no additional labor, materials, equipment, appliances or devices are mandated beyond what is currently required by the code nor are the code requirements made more stringent.

Report of Committee Action Hearings

Committee Action:

Approved as Submitted

Committee Reason: Approval was based on the proponent's published reason statements.

Assembly Action:

None

Final Action Results

RM21-15

AS

Code Change No: **RM22-15**

Original Proposal

Section: M1507.2

Proponent: Janine Snyder, representing Plumbing, Mechanical, and Fuel Gas Code Action Committee (PMGCAC@iccsafe.org)

Revise as follows:

M1507.2 Recirculation of air. Exhaust air from bathrooms and toilet rooms shall not be recirculated within a residence or circulated to another *dwelling unit* and shall be exhausted directly to the outdoors. Exhaust air from bathrooms ~~and~~ toilet rooms and kitchens shall not discharge into an *attic*, crawl space or other areas inside the building. This section shall not prohibit the installation of ductless range hoods in accordance with the exception to Section M1503.1.

Reason: This section fails to include kitchen exhaust. The code should not allow kitchen exhaust to discharge to another dwelling unit or to an attic, crawl space, etc. any more than it should allow the same for toilet and bathroom exhaust. The new added last sentence makes sure that ductless range hoods are not prohibited because such simulated exhaust devices are allowed by Section M1503.1 as long as other ventilation is provided for the kitchen.

This proposal is submitted by the ICC Plumbing, Mechanical and Fuel Gas Code Action Committee (PMGCAC) The PMGCAC was established by the ICC Board of Directors to pursue opportunities to improve and enhance assigned International Codes or portions thereof. This includes both the technical aspects of the codes and the code content in terms of scope and application of referenced standards. The PMGCAC has held one open meeting and multiple conference calls which included members of the PMGCAC. Interested parties also participated in all conference calls to discuss and debate the proposed changes.

Cost Impact: Will increase the cost of construction

This proposal will increase the cost of construction in those cases where the kitchen exhaust would have been recirculated or discharged to a location other than outdoors.

Report of Committee Action Hearings

Committee Action:

Approved as Submitted

Committee Reason: Approval was based on the proponent's published reason statements.

Assembly Action:

None

Final Action Results

RM22-15

AS

Code Change No: **RM23-15**

Original Proposal

Section: M1507.3 (New)

Proponent: Mike Moore, Newport Ventures, representing Broan-NuTone, representing Newport (mmoore@newportventures.net)

Add new text as follows:

M1507.3 Ventilating equipment. Exhaust equipment serving single dwelling units shall be listed and labeled as providing the minimum required air flow in accordance with ANSI/AMCA 210-ANSI/ASHRAE 51.

Reason: Industry experience and research have shown that "for advertised airflows that are not certified, the actual installed airflow can be a small fraction of the advertised value".¹ Without a code minimum requirement for listing and labeling flows in accordance with an ANSI standard, there is nothing in place to stop a manufacturer from reporting an airflow under whatever conditions they please (e.g., the condition with no duct work attached). Requiring listing and labeling of ventilating equipment per ANSI/AMCA 210 - ANSI/ASHRAE 51 is the first step in ensuring that fans perform to expectations. In 2015, the IRC adopted a requirement for fans to be tested per ANSI/AMCA 210 - ANSI/ASHRAE 51 when using prescriptive duct sizing Table M1506.2 (see footnote "a"). This proposal would simply elevate that requirement from a footnote to a place where it can actually be seen within the code. Listing and labeling of products tested to this standard is maintained by the Home Ventilating Institute, which has been in operation for decades. Verification of listing and labeling to this standard can be accomplished by visually inspecting the equipment for an HVI sticker or by looking up the equipment in the on-line database.² Certification by HVI in accordance with ANSI/AMCA 210 - ANSI/ASHRAE 51 is already required by ASHRAE 62.2, ENERGY STAR for Homes, and the State of California, among other groups. Roughly 12,000 ventilating equipment products are listed, labeled, and can be referenced in the HVI directory.

Bibliography:

1. Singer, B. C., Delp, W. W., Apte, M., & Price, P. N. (2011). Performance of Installed Cooking Exhaust Devices. LBNL-5265E. Berkeley, CA: Lawrence Berkeley National Laboratory.
2. Home Ventilating Institute. HVI-Certified Products Directory. <http://hvi.org/proddirectory/index.cfm> . Accessed December 10, 2014.

Cost Impact: Will increase the cost of construction

Over 12,000 ventilating equipment products are labeled and listed in the HVI directory. These fans are tested for airflow in accordance with ANSI/AMCA 210-ANSI/ASHRAE 51. For these products, there will be no incremental cost associated with this change. For equipment that is not currently tested, listed, and labeled, the incremental costs are highly dependent upon volume of the specific products sold.

Analysis: A review of the standard proposed for inclusion in the code, ANSI/AMCA 210- ANSI/ASHRAE 51 , with regard to the ICC criteria for referenced standards (Section 3.6 of CP#28) will be posted on the ICC website on or before April 2, 2015.

Report of Committee Action Hearings

Committee Action:

Approved as Submitted

Committee Reason: Approval was based on the proponent's published reason statements. Fans don't always perform as purported.

Assembly Action:

None

Final Action Results

RM23-15

AS

Code Change No: **RM26-15**

Original Proposal

Section: M1507.3.3, Chapter 44

Proponent: Robert Schwarz, EnergyLogic, Inc., representing EnergyLogic, Inc. (robby@nrglogic.com)

Revise as follows:

M1507.3.3 Mechanical ventilation rate. The whole-house mechanical ventilation system shall provide outdoor air at a continuous rate ~~of not less than that as~~ determined in accordance with Table M1507.3.3(1) or in accordance with Equation 15-1.

Equation 15-1

Ventilation rate =(0.01 CFM x total square foot area of house) + [(number of bedrooms +1) x 7.5 CFM]

Exception: The whole-house mechanical ventilation system is permitted to operate intermittently where the system has controls that enable operation for not less than 25-percent of each 4-hour segment and the ventilation rate prescribed in Table M1507.3.3(1) is multiplied by the factor determined in accordance with Table M1507.3.3(2).

Reference standards type:

Add new standard(s) as follows:

ASHRAE 62.2 - 2010 Ventilation and Acceptable Indoor Air Quality in Low-Rise Residential Buildings

Reason: Many Builders and Designers would like to be more precise in the specification of the air that is utilized to ventilate a home. The table is good to ensure that ventilation is occurring in a home and for a quick guide for the quantity of air that is needed for whole house mechanical ventilation, but the formula is more precise especially for homes that are on the small side in the floor area chart.

M1507.3.3 Mechanical ventilation rate. The whole-house mechanical ventilation system shall provide outdoor air at a continuous rate of not less than that determined in accordance with Table M1507.3.3(1).

Exception: The whole-house mechanical ventilation system is permitted to operate intermittently where the system has controls that enable operation for not less than 25-percent of each 4-hour segment and the ventilation rate prescribed in Table M1507.3.3(1) is multiplied by the factor determined in accordance with Table M1507.3.3(2).

TABLE M1507.3.3(1)
CONTINUOUS WHOLE-HOUSE MECHANICAL VENTILATION SYSTEM AIRFLOW RATE REQUIREMENTS

DWELLING UNIT FLOOR AREA (square feet)	NUMBER OF BEDROOMS				
	0 - 1	2 - 3	4 - 5	6 - 7	> 7
	Airflow in CFM				
< 1,500	30	45	60	75	90
1,501 - 3,000	45	60	75	90	105
3,001 - 4,500	60	75	90	105	120
4,501 - 6,000	75	90	105	120	135
6,001 - 7,500	90	105	120	135	150
> 7,500	105	120	135	150	165

For SI: 1 square foot = 0.0929 m², 1 cubic foot per minute = 0.0004719 m³/s.

TABLE M1507.3.3(2)
INTERMITTENT WHOLE-HOUSE MECHANICAL VENTILATION RATE FACTORS^{a, b}

RUN-TIME PERCENTAGE IN EACH 4-HOUR SEGMENT	25%	33%	50%	66%	75%	100%
Factor ^a	4	3	2	1.5	1.3	1.0

a. For ventilation system run time values between those given, the factors are permitted to be determined by interpolation.

b. Extrapolation beyond the table is prohibited.

M1507.3.3 Mechanical ventilation rate. The whole house mechanical ventilation system shall provide outdoor air at a continuous rate of not less than that as determined in accordance with Table M1507.3.3(1) or the ASHRAE 62.2 formula (0.01 CFM x total sqft of house) + ((number of bedrooms + 1) x 7.5CFM) .

Rational Statement:

Many Builders and Designers would like to be more precise in the specification of the air that is utilized to ventilate a home. The table is good to ensure that ventilation is occurring in a home and for a quick guide for the quantity of air that is needed for whole house mechanical ventilation, but the formula is more precise especially for homes that are on the small side in the floor area chart.

TABLE M1507.3.3(1)

CONTINUOUS WHOLE-HOUSE MECHANICAL VENTILATION SYSTEM AIRFLOW RATE REQUIREMENTS

DWELLING UNIT FLOOR AREA (square feet)	NUMBER OF BEDROOMS				
	0 – 1	2 – 3	4 – 5	6 – 7	> 7
< 1,500	30	45	60	75	90
1,501 – 3,000	45	60	75	90	105
3,001 – 4,500	60	75	90	105	120
4,501 – 6,000	75	90	105	120	135
6,001 – 7,500	90	105	120	135	150
> 7,500	105	120	135	150	165

- Ventilation can't be greater than what is calculated by formula

$$\text{Fan flow (CFM)} = 0.01 \text{ CFM} \times \text{your floor area} + 7.5 \times (\text{your number of bedrooms} + 1)$$

- For a 1,510 square foot 4-bedroom home,
 - (0.01 X 1510) + (7.5 times 5)
 - (15.1) + (37.5)
 - Formula Result: 52.6 CFM
 - Chart Result: 75 CFM



Cost Impact: Will not increase the cost of construction
No cost increase. Possible cost reductions by using more accurate ventilation requirements

Analysis: A review of the standard proposed for inclusion in the code, ASHRAE 62.2, with regard to the ICC criteria for referenced standards (Section 3.6 of CP#28) will be posted on the ICC website on or before April 2, 2015.

Report of Committee Action Hearings

Committee Action:

Approved as Submitted

Committee Reason: Approval was based on the proponent's published reason statements.

Assembly Action:

None

Final Action Results

RM26-15

AS

Code Change No: **RM31-15**

Original Proposal

Section: M1601.1.1

Proponent: Guy McMann, Jefferson County Colorado, representing Colorado Association of Plumbing and Mechanical Officials (CAPMO) (gmcman@jeffco.us)

Revise as follows:

M1601.1.1 Above-ground duct systems. Above-ground *duct systems* shall conform to the following:

1. *Equipment* connected to *duct systems* shall be designed to limit discharge air temperature to not greater than 250°F (121°C).
2. Factory-made ducts shall be listed and labeled in accordance with UL 181 and installed in accordance with the manufacturer's instructions.
3. Fibrous glass duct construction shall conform to the SMACNA *Fibrous Glass Duct Construction Standards* or NAIMA *Fibrous Glass Duct Construction Standards*.
4. Field-fabricated and shop-fabricated metal and flexible duct constructions shall conform to the SMACNA *HVAC Duct Construction Standards—Metal and Flexible* except as allowed by Table M1601.1.1. Galvanized steel shall conform to ASTM A 653.
5. The use of gypsum products to construct return air ducts or plenums is permitted, provided that the air temperature does not exceed 125°F (52°C) and exposed surfaces are not subject to condensation.
6. *Duct systems* shall be constructed of materials having a flame spread index of not greater than 200.
7. Stud wall cavities and the spaces between solid floor joists to be used as air plenums shall comply with the following conditions:
 - 7.1 These cavities or spaces shall not be used as a plenum for supply air.
 - 7.2 These cavities or spaces shall not be part of a required fire-resistance-rated assembly.
 - 7.3 Stud wall cavities shall not convey air from more than one floor level.
 - 7.4 Stud wall cavities and joist-space plenums shall be isolated from adjacent concealed spaces by tight-fitting fireblocking in accordance with Section R602.8.
 - 7.5 Stud wall cavities in the outside walls of building envelope assemblies shall not be utilized as air plenums.
8. Volume dampers, equipment and other means of supply, return and exhaust air adjustment used in system balancing shall be provided with access.

Reason: This language is absent in the IRC and is critical that access be provided for these devices in order to properly balance a system.

Cost Impact: Will increase the cost of construction
It is possible that an increase in cost might occur if access doors need to be purchased. Otherwise not.

Report of Committee Action Hearings

Committee Action:

Approved as Submitted

Committee Reason: Approval was based on the proponent's published reason statements.

Assembly Action:

None

Final Action Results

RM31-15

AS

Code Change No: **RM34-15**

Original Proposal

Section: M1601.1.2

Proponent: Jay Peters, Codes and Standards International, representing AQC Industries (peters.jay@me.com)

Revise as follows:

M1601.1.2 Underground duct systems. Underground *duct systems* shall be constructed of *approved* concrete, clay, metal or plastic. The maximum ~~duct design~~ temperature for ~~systems utilizing plastic ducts, duct and fittings shall not be greater than~~ 150°F (66°C). Metal ducts shall be protected from corrosion in an *approved* manner or shall be completely encased in concrete not less than 2 inches (51 mm) thick. Nonmetallic ducts shall be installed in accordance with the manufacturer's instructions. Plastic pipe and fitting materials shall conform to cell classification 12454-B of ASTM D 1248 or ASTM D 1784 and external loading properties of ASTM D 2412. Ducts shall slope to an accessible point for drainage. ~~Where encased in concrete, ducts~~ Ducts shall be sealed, secured and secured-tested with air at a pressure of not less than 2 inches of W.C. for not less than 5 minutes in the presence of the code official prior to any encasing the ducts in concrete being poured or direct burial. Metallic ducts having an *approved* protective coating and nonmetallic ducts shall be installed in accordance with the manufacturer's instructions.

Reason: This air temperature language does not change the substantive technical content of the provision but uses the exact same language as the IMC to bring uniformity to the codes.

All duct leakage, whether in the envelope, in the attic, or underground is undesirable but underground ducts are more likely to cause serious issues due to their location. Underground ducts systems have a propensity to leak which causes air exfiltration (loss) and also duct infiltration (gain) of contaminants into the duct system and residence. The leakage, in-and-out, not only causes poor indoor air quality, duct system degradation, sick building occupants, mold, mildew and even radon contamination, but also wastes energy. Some estimate that after the combined infiltration from walls/ceilings/floors, the duct system is the next largest cause of air leakage in the residence. Underground return air ducts are of particular concern due to the negative pressure within the duct system, causing intake of impurities. All ducts are to be sealed before burial, whether in concrete or directly buried in the ground but the code does not require any verification or test to prove the system is airtight, or more importantly, watertight. Metallic ducts encased in concrete, as well as those approved for direct burial should be tested to find leaks before burial, not afterwards, or never at all.

Cost Impact: Will increase the cost of construction

Although I have checked the box for additional cost, underground duct systems, when installed by quality contractors and installed correctly should already be performing this test. The proposal for air test may add a minimal cost to initial installation but has potential to save money in the long run through greater energy savings, indoor air quality and future repairs.

Report of Committee Action Hearings

Committee Action:

Approved as Modified

Modify proposal as follows:

M1601.1.2 Underground duct systems. Underground duct systems shall be constructed of approved concrete, clay, metal or plastic. The maximum design temperature for systems utilizing plastic duct and fittings shall be 150°F (66°C). Metal ducts shall be protected from corrosion in an approved manner or shall be completely encased in concrete not less than 2 inches (51 mm) thick. Nonmetallic ducts shall be installed in accordance with the manufacturer's instructions. Plastic pipe and fitting materials shall conform to cell classification 12454-B of ASTM D 1248 or ASTM D 1784 and external loading properties of ASTM D 2412. Ducts shall slope to an accessible point for drainage. Ducts shall be sealed, secured and tested ~~with air at a pressure of not less than 2 inches of W.C. for not less than 5 minutes in the presence of the code official~~ prior to encasing the ducts in concrete or direct burial. Duct tightness shall be verified as required by Section 1103.3. Metallic ducts having an approved protective coating and nonmetallic ducts shall be installed in accordance with the manufacturer's instructions.

Committee Reason: Approval was based on the proponent's published reason statements. The modification substitutes the preferred testing method from Chapter 11.

Assembly Action:

None

Final Action Results

RM34-15

AM

Code Change No: **RM36-15**

Original Proposal

Section: M1601.4.1

Proponent: Donald Surrena, National Association of Home Builders, representing National Association of Home Builders (dsurrena@nahb.org)

Revise as follows:

M1601.4.1 Joints, seams and connections. Longitudinal and transverse joints, seams and connections in metallic and nonmetallic ducts shall be constructed as specified in SMACNA HVAC *Duct Construction Standards—Metal and Flexible* and NAIMA *Fibrous Glass Duct Construction Standards*. Joints, longitudinal and transverse seams, and connections in ductwork shall be securely fastened and sealed with welds, gaskets, mastics (adhesives), mastic-plus-embedded-fabric systems, liquid sealants or tapes. Tapes and mastics used to seal fibrous glass ductwork shall be *listed* and *labeled* in accordance with UL 181A and shall be marked "181A-P" for pressure-sensitive tape, "181 A-M" for mastic or "181 A-H" for heat-sensitive tape.

Tapes and mastics used to seal metallic and flexible air ducts and flexible air connectors shall comply with UL 181B and shall be marked "181 B-FX" for pressure-sensitive tape or "181 BM" for mastic. Duct connections to flanges of air distribution system equipment shall be sealed and mechanically fastened. Mechanical fasteners for use with flexible nonmetallic air ducts shall comply with UL 181B and shall be marked 181B-C. Crimp joints for round metallic ducts shall have a contact lap of not less than 1 inch (25 mm) and shall be mechanically fastened by means of not less than three sheet-metal screws or rivets equally spaced around the joint.

Closure systems used to seal all ductwork shall be installed in accordance with the manufacturers' instructions.

Exceptions:

1. Spray polyurethane foam shall be permitted to be applied without additional joint seals.
2. Where a duct connection is made that is partially inaccessible, three screws or rivets shall be equally spaced on the exposed portion of the joint so as to prevent a hinge effect.
3. For ducts having a static pressure classification of less than 2 inches of water column (500 Pa), additional closure systems shall not be required for continuously welded joints and seams and locking-type joints and seams of other than the snap-lock and button-lock types that are located outside of conditioned spaces.

Reason: This proposal will reduce construction cost and still reduce energy loss that would occur due to duct leakage outside conditioned space. Low pressure longitudinal seam duct leakage is very limited and the small amount of leakage within conditioned space is still useful energy.

Cost Impact: Will not increase the cost of construction
Cost decrease of up to \$314 for an average house according to research conducted by Home Innovation Research Labs.

Report of Committee Action Hearings

Committee Action:

Approved as Submitted

Committee Reason: Approval was based on the proponent's published reason statements.

Assembly Action:

None

Final Action Results

RM36-15

AS

Code Change No: **RM37-15**

Original Proposal

Section: M1602.2

Proponent: Guy McMann, Jefferson County Colorado, representing Colorado Association of Plumbing and Mechanical Officials (CAPMO) (gmcmann@jeffco.us)

Revise as follows:

M1602.2 Return air openings. Return air openings for heating, ventilation and air conditioning systems shall comply with all of the following:

1. Openings shall not be located less than 10 feet (3048 mm) measured in any direction from an open combustion chamber or draft hood of another appliance located in the same room or space.
2. The amount of return air taken from any room or space shall be not greater than the flow rate of supply air delivered to such room or space.
3. Return and transfer openings shall be sized in accordance with the appliance or equipment manufacturers' installation instructions, Manual D or the design of the registered design professional.
4. Return air shall not be taken from a closet, bathroom, toilet room, kitchen, garage, mechanical room, boiler room, furnace room or unconditioned attic.

Exceptions:

1. Taking return air from a kitchen is not prohibited where such return air openings serve the kitchen only, and are located not less than 10 feet (3048 mm) from the cooking appliances.
2. Dedicated forced-air systems serving only the garage shall not be prohibited from obtaining return air from the garage.
5. Taking return air from an unconditioned crawl space shall not be accomplished through a direct connection to the return side of a forced-air furnace. Transfer openings in the crawl space enclosure shall not be prohibited.
6. Return air from one dwelling unit shall not be discharged into another dwelling unit.
7. For other than dedicated HVAC systems, return air shall not be taken from indoor swimming pool enclosures and associated deck areas except where the air in such spaces is dehumidified.

Reason: It is not desirable to pull return air from swimming pool areas due to the affects it would have on the system from humidity and chemical odors associated with such spaces. A dedicated system would be required or a combination of supply and exhaust. This scenario is consistent with the same dwelling built under the IMC.

Cost Impact: Will not increase the cost of construction

Generally speaking this proposal is will not cause an increase is cost. If dehumidification is chosen then there could be an increase in cost.

Report of Committee Action Hearings
--

Committee Action:**Approved as Submitted****Committee Reason:** Approval was based on the proponent's published reason statement.**Assembly Action:****Disapprove**

Public Comments

Public Comment 1:

Guy McMann, Jefferson County Co., representing Colorado Association of Plumbing and Mechanical Officials (CAPMO) (gmcman@jeffco.us) requests Approve as Modified by this Public Comment.

Modify as follows:

M1602.2 Return air openings. Return air openings for heating, ventilation and air conditioning systems shall comply with all of the following:

1. Openings shall not be located less than 10 feet (3048 mm) measured in any direction from an open combustion chamber or draft hood of another appliance located in the same room or space.
2. The amount of return air taken from any room or space shall be not greater than the flow rate of supply air delivered to such room or space.
3. Return and transfer openings shall be sized in accordance with the appliance or equipment manufacturers' installation instructions, Manual D or the design of the registered design professional.
4. Return air shall not be taken from a closet, bathroom, toilet room, kitchen, garage, mechanical room, boiler room, furnace room or unconditioned attic.

Exceptions:

1. Taking return air from a kitchen is not prohibited where such return air openings serve the kitchen only, and are located not less than 10 feet (3048 mm) from the cooking appliances.
2. Dedicated forced-air systems serving only the garage shall not be prohibited from obtaining return air from the garage.
5. Taking return air from an unconditioned crawl space shall not be accomplished through a direct connection to the return side of a forced-air furnace. Transfer openings in the crawl space enclosure shall not be prohibited.
6. Return air from one dwelling unit shall not be discharged into another dwelling unit.
7. Return air shall not be taken from indoor swimming pool enclosures and associated deck areas except where such space is dehumidied.

Commenter's Reason: The committees concern that the original language seemed to exclude dedicated systems was valid. This correction clearly excludes dedicated systems from the requirements of untreated recirculation to other spaces.

Final Action Results

RM37-15**AMPC1**

Code Change No: **RM39-15**

Original Proposal

Section: M2006.1, M2006.3, Chapter 44

Proponent: Jennifer Hatfield, J. Hatfield & Associates, PL, representing Association of Pool & Spa Professionals (jhatfield@apsp.org)

Revise as follows:

M2006.1 General. Pool and spa heaters shall be installed in accordance with the manufacturer's installation instructions. Oil-fired pool heaters shall comply with UL 726. Electric pool and spa heaters shall comply with UL 1261, UL 1563 or CSA C22.2 No. 218.1. Gas-fired pool heaters shall comply with ANSI Z21.56/CSA 4.7. Pool and spa heat pump water heaters shall comply with UL 1995, AHRI 1160, or CSA C22.2 No. 236.

Delete without substitution:

~~**M2006.3 Temperature limiting devices.** Pool heaters shall have temperature relief valves.~~

Reference standards type:

Add new standard(s) as follows:

AHRI 1160 (I-P) -09 Performance rating of Heat Pump Pool Heaters

ANSI Z21.56a/CSA 4.7 -2013 Gas Fired Pool Heaters

CSA C22.2 No. 236-11 Cooling Equipment

CSA C22.2 No. 218.1-M89(R2011) Spas, Hot Tubs and Associated Equipment

UL 1563-2009 Standard for Electric Spas, Hot Tubs and Associated Equipment-with revisions through July 2012

Reason: This proposal is needed to ensure consistency with what standards are required for the various pool heaters in Section 316.2 and Table 316.2 of the International Swimming Pool & Spa Code.

Further, section M2006.3 needs to be removed because it is out of date and not compatible with the current heaters on the market. For example, UL Standard 1995 does not require a temperature relief valve for two reasons: (1) If a condition exists whereby the thermostat fails to turn off the heat pump, the outlet water temperature is effectively controlled by the compressor high pressure control and/or internal pressure control. Long before the outlet water reaches an unacceptably high temperature, the refrigeration system high pressure control and/or the compressor internal pressure control will trip and shut off the compressor. (2) A pool, spa or hot tub is an open system, unlike a water heater tank that can allow pressure to build. Excess pressure developed as a result of excessive temperatures in the heat pump are relieved through the pool, spa or hot tub.

Bibliography: International Swimming Pool & Spa Code, Section 316.2 and Table 316.2

Cost Impact: Will not increase the cost of construction

This proposal will prevent an increase in cost because without it, a jurisdiction may require a temperature relief valve in products that are not currently listed to have one.

Analysis: A review of the standard proposed for inclusion in the code, AHRI 1160, ANSI Z21.56/CSA 4.7, CSA C22.2 No 218.1, CSA C22.2 No. 236 and UL 1563, with regard to the ICC criteria for referenced standards (Section 3.6 of CP#28) will be posted on the ICC website on or before April 2, 2015.

Report of Committee Action Hearings
--

Committee Action:**Approved as Modified****Modify proposal as follows:**

M2006.1 General. Pool and spa heaters shall be installed in accordance with the manufacturer's installation instructions. Oil-fired pool heaters shall comply with UL 726. Electric pool and spa heaters shall comply with UL 1261, ~~UL 1563 or CSA C22.2 No. 218.1.~~ Gas-fired pool heaters shall comply with ~~ANSI Z21.56/CSA 4.7.~~ Pool and spa heat pump water heaters shall comply with UL 1995, AHRI 1160, or CSA C22.2 No. 236.

Exception: Portable residential spas and portable residential exercise spas shall comply with UL 1563 or CSA C22.2 No. 218.1.

Committee Reason: Approval was based on the proponent's published reason statements. The modifications update the standards to be current with industry.

Assembly Action:**None**

Final Action Results

RM39-15**AM**

Code Change No: **RM40-15**

Original Proposal

Section: Table M2101.1, M2103.3

Proponent: Curtis Dady, Viega, LLC, representing Viega, LLC (curtis.dady@viega.us)

Revise as follows:

**TABLE M2101.1
HYDRONIC PIPING AND FITTING MATERIALS**

MATERIAL	USE CODE ^a	STANDARD ^b	JOINTS	NOTES
Copper tubing (type K, L or M)	1, 2	ASTM B 75, B 88, B 251, B 306, <u>ASME B16.51</u>	Brazed, soldered, <u>press-connected</u> and flared mechanical fittings	Joins embedded in concrete

(Portions of table not shown remain unchanged)

For SI: °C = [(°F)-32]/1.8.

a. Use code:

1. Above ground.
2. Embedded in radiant systems.
3. Temperatures below 180°F only.
4. Low temperature (below 130°F) applications only.
5. Temperatures below 160°F only.

b. Standards as listed in Chapter 44.

M2103.3 Piping joints. Copper and copper alloy systems shall be soldered, brazed, or press-connected. Soldering shall be in accordance with ASTM B 828. Fluxes for soldering shall be in accordance with ASTM B 813. Brazing fluxes shall be in accordance with AWS A5.31. Press-connect shall be in accordance with ASME B16.51. Piping joints that are embedded shall be installed in accordance with the following requirements:

1. Steel pipe joints shall be welded.
2. Copper tubing shall be joined by brazing complying with Section P3003.6.1.
3. Polybutylene pipe and tubing joints shall be installed with socket-type heat-fused polybutylene fittings.
4. CPVC tubing shall be joined using solvent cement joints.
5. Polypropylene pipe and tubing joints shall be installed with socket-type heat-fused polypropylene fittings.
6. Cross-linked polyethylene (PEX) tubing shall be joined using cold expansion, insert or compression fittings.
7. Raised temperature polyethylene (PE-RT) tubing shall be joined using insert or compression fittings.

Reason: ASME B16.51 "Copper and Copper Alloy Press-Connect Pressure Fittings" is included in IMC table 1202.5 HYDRONIC PIPE FITTINGS and these joints are included in sections 1203.8 and 1203.8.3.

Cost Impact: Will not increase the cost of construction
Addition of option, not requirement.

Report of Committee Action Hearings
--

Committee Action:

Approved as Modified

Modify as follows:

TABLE M2101.1
HYDRONIC PIPING AND FITTING MATERIALS
(No change to Table)

Committee Reason: Approval is based on the proponent's published reason statements. The modification corrects the the table title.

Assembly Action:

Disapprove

Public Comments

Public Comment 1:

Julius Ballanco, JB Engineering and Code Consulting, P.C., representing Self (JBENGINEER@aol.com) requests Approve as Modified by this Public Comment.

Modify as follows:

M2103.3 Piping joints. Copper and copper alloy systems shall be soldered, brazed, or press-connected. Soldering shall be in accordance with ASTM B 828. Fluxes for soldering shall be in accordance with ASTM B 813. Brazing fluxes shall be in accordance with AWS A5.31. Press-connect joints shall be made in accordance with ~~ASME B16.51~~ the manufacturer's installation instructions. Piping joints that are embedded shall be installed in accordance with the following requirements:

1. Steel pipe joints shall be welded.
2. Copper tubing shall be joined by brazing complying with Section P3003.6.1.
3. Polybutylene pipe and tubing joints shall be installed with socket-type heat-fused polybutylene fittings.
4. CPVC tubing shall be joined using solvent cement joints.
5. Polypropylene pipe and tubing joints shall be installed with socket-type heat-fused polypropylene fittings.
6. Cross-linked polyethylene (PEX) tubing shall be joined using cold expansion, insert or compression fittings.
7. Raised temperature polyethylene (PE-RT) tubing shall be joined using insert or compression fittings.

Commenter's Reason: ASME B16.51 contains no requirements for the installation of press-connect fittings. This section regulates installation, not fitting standards. The fitting manufacturer is required to provide the installation instructions for press connect fittings. It is inappropriate to reference the standard when no installation requirements are found in the standard.

Final Action Results

RM40-15

AMPC1

Code Change No: **RM41-15**

Original Proposal

Section: Table M2101.1, Table M2105.4

Proponent: Michael Cudahy (mikec@cmservices.com)

Revise as follows:

**TABLE M2101.1
HYDRONIC PIPING MATERIALS**

MATERIAL	USE CODE ^a	STANDARD ^b	JOINTS	NOTES
Cross-linked polyethylene (PEX)	1, 2, 3	ASTM F 876, F 877	(See PEX fittings)	Install in accordance with manufacturer's instructions

(Portions of table and notes not shown remain unchanged)

**TABLE M2105.4
GROUND-SOURCE LOOP PIPE**

MATERIAL	STANDARD
Cross-linked polyethylene (PEX)	ASTM F 876; ASTM F 877 CSA B137.5

(Portions of table not shown remain unchanged)

Reason: ASTM F877 has been revised a few years ago to remove redundant pipe/tubing dimensional and performance specifications which are otherwise specified in ASTM F876. F877 remains a PEX fitting and PEX system materials and performance standard exclusive for use with ASTM F876 piping/tubing.

Cost Impact: Will not increase the cost of construction

This proposal simply deletes a standard that is no longer pipe or tubing related from the code. The piping material is now covered by a different standard, and as such, the option is not deleting or adding a material. Thus the code with this proposal added will not cause the cost of construction to increase.

Report of Committee Action Hearings

Committee Action:

Approved as Submitted

Committee Reason: Approval was based on the proponent's published reason statements.

Assembly Action:

None

Final Action Results

RM41-15

AS

Code Change No: **RM42-15**

Original Proposal

Section: Table M2101.1

Proponent: Pennie L Feehan, representing Copper Development Association (penniefeehan@me.com)

Revise as follows:

**TABLE M2101.1
HYDRONIC PIPING MATERIALS**

MATERIAL	USE CODE ^a	STANDARD ^b	JOINTS	NOTES
Brass pipe	4	ASTM B 43	Brazed, welded, threaded, mechanical and flanged fittings	
Brass tubing	4	ASTM B 135	Brazed, soldered and mechanical fittings	
Copper <u>and copper-alloy</u> pipe	1	ASTM B42, B43, B302	Brazed, soldered and mechanical fittings threaded, welded and flanged	
Copper and copper-alloy tubing (type K, L or M)	1, 2	ASTM B75, B88, B135, B251, B306	Brazed, soldered and flared mechanical fittings	Joints embedded in concrete <u>shall be brazed</u>

(Portions of table not shown remain unchanged)

For SI: °C = [(°F)-32]/1.8.

a. Use code:

1. Above ground.
2. Embedded in radiant systems.
3. Temperatures below 180°F only.
4. Low temperature (below 130°F) applications only.
5. Temperatures below 160°F only.

b. Standards as listed in Chapter 44.

Reason: The proposal removes brass because brass is a copper alloy and the standards and requirements are covered in the copper & copper-alloy lines. The requirement under note was incomplete comment and did not make sense.

Cost Impact: Will not increase the cost of construction

This proposal will not increase the cost of construction as it is editorial in nature.

Report of Committee Action Hearings

Committee Action:

Approved as Submitted

Committee Reason: Approval was based on the proponent's published reason statements.

Assembly Action:

None

Final Action Results

RM42-15

AS

Code Change No: **RM43-15**

Original Proposal

Section: Table M2101.1, Table M2105.4, Table M2105.5, M2105.13, M2105.13.3 (New), M2105.13.4 (New), Chapter 44

Proponent: Larry Gill, representing IPEX USA LLC (larry.gill@ipexna.com)

Revise as follows:

**TABLE M2101.1
HYDRONIC PIPING MATERIALS**

MATERIAL	USE CODE ^a	STANDARD ^b	JOINTS	NOTES
Raised temperature polyethylene (PE-RT)	1, 2, 3	ASTM F 2623 ASTM F 2769 <u>CSA B137.18</u>	Copper crimp/insert fitting stainless steel clamp, insert fittings	
Raised Temperature Polyethylene (PE-RT) fittings	1, 2,3	ASTM F 1807 ASTM F 2159 ASTM F 2735 ASTM F 2769 ASTM F 2098 <u>ASTM D3261</u> <u>CSA B137.18</u>	Copper crimp/insert fitting stainless steel clamp, insert fittings	

(Portions of table not shown remain unchanged)

**TABLE M2105.4
GROUND-SOURCE LOOP PIPE**

MATERIAL	STANDARD
Raised temperature polyethylene (PE-RT)	ASTM F 2623; ASTM F 2769; <u>CSA B137.18</u>

(Portions of table not shown remain unchanged)

**TABLE M2105.5
GROUND-SOURCE LOOP PIPE FITTINGS**

PIPE MATERIAL	STANDARD
Raised temperature polyethylene (PE-RT)	ASTM D 3261; ASTM F 1807; ASTM F 2159; <u>ASTM F 2769</u> ; <u>CSA B137.1</u> ; <u>ASTM F1055</u> , <u>ASTM F2098</u> , <u>ASTM F2735</u> , <u>ASTM D2683</u> , <u>ASTM D3261</u> , <u>CSA B137.18</u>

(Portions of table not shown remain unchanged)

M2105.13 Raised temperature polyethylene (PE-RT) plastic tubing. Joints between raised temperature polyethylene tubing and fittings shall comply with Sections M2105.13.1, M2105.13.2, M2105.13.3, and M2105.13.4. Mechanical joints shall comply with Section M2105.8.1.

Add new text as follows:

M2105.13.3 Heat fusion joints. Heat fusion joints shall be of the socket-fusion, saddle-fusion or butt-fusion type, and shall be joined in accordance with ASTM D2657. Joint surfaces shall be clean and free of moisture. Joint surfaces shall be heated to melt temperatures and joined. The joint shall remain undisturbed until cool. Fittings shall be manufactured in accordance with ASTM D2683 or ASTM D3261.

M2105.13.4 Electrofusion joints Joints shall be of the electrofusion type. Joint surfaces shall be clean and free of moisture and scoured to expose virgin resin. Joint surfaces shall be heated to melt temperatures to a time specified by the manufacturer and joined. The joint shall remain undisturbed until cool. Fittings shall be manufactured in accordance with ASTM F1055.

Reference standards type:**Add new standard(s) as follows:**

CSA B137.18 - 2013 - Polyethylene of raised temperature (PE-RT) tubing systems for pressure applications.

Reason: Add new CSA B137.18 - Polyethylene of raised temperature resistance (PE-RT) tubing systems for pressure applications to Tables M2101.1, M2105.4, and M2105.5 (scope includes hydronic heating and ground source loop pipe and fittings).

Add reference to ASTM D3261 which is a consensus standard for PE fusion to Table M2101.1 and Table M2105.5

Add references to ASTM F1055, ASTM F2098, ASTM F2735, and ASTM D2683 to Table M2105.5. ASTM F2098 and ASTM F2735 are already referenced in the IMC for PE-RT fittings. ASTM F1055 and ASTM D2683 are being added for fused PE joints.

Add new sections M2105.13.3 and M2105.13.4 to permit fusion of PE-RT joints.

The addition of these PE-RT standards will provide alternatives to the standards already in the Code.

Cost Impact: Will not increase the cost of construction

No cost impact. These changes provide alternatives to PERT pipe and fittings standards only. No changes in cost to the current Code provisions.

Analysis: A review of the standard proposed for inclusion in the code, CSA B137.18, with regard to the ICC criteria for referenced standards (Section 3.6 of CP#28) will be posted on the ICC website on or before April 2, 2015.

Report of Committee Action Hearings
--

Committee Action:**Approved as Submitted****Committee Reason:** Approval was based on the proponent's published reason statements.**Assembly Action:****None**

Final Action Results

RM43-15**AS**

Code Change No: **RM44-15**

Original Proposal

Section: Table M2101.9

Proponent: Michael Cudahy (mikec@cmservices.com)

Revise as follows:

**TABLE M2101.9
HANGER SPACING INTERVALS**

PIPING MATERIAL	MAXIMUM HORIZONTAL SPACING (feet)	MAXIMUM VERTICAL SPACING (feet)
PEX tubing \leq 1 inch	2.67	4
PEX tubing \geq 1 1/4 inches	<u>4</u>	<u>10a</u>

(Portions of table not shown remain unchanged)

For SI: 1 inch = 25.4 mm, 1 foot = 304.8 mm.

- a. For sizes 2 inches and smaller, a guide shall be installed midway between required vertical supports. Such guides shall prevent pipe movement in a direction perpendicular to the axis of the pipe.

Reason: The 2015 code cycle for the IRC included updates to the support spacing for both PEX and PE-RT tubing for sizes larger than 1". The IRC-P Table P2605.1 is current and correct and should be used as the base template for all other tables within the ICC codes as identified in this amendment proposal. The horizontal support spacing for both PEX and PE-RT tubing (piping) up to and including 1" size is 32" (2-2/3Ft) and 48" (4Ft) for sizes 1- 1/4" and larger. These dimensions are consistent with all published PEX literature and manufacture's installation instructions.

Cost Impact: Will not increase the cost of construction

This proposal modifies the spacing for piping material support into the code and thus the code with this proposal added will not cause the cost of construction to increase, and could decrease the cost as less support is required for larger pipe.

Report of Committee Action Hearings

Committee Action:

Approved as Submitted

Committee Reason: Approval was based on the proponent's published reason statements.

Assembly Action:

None

Final Action Results

RM44-15

AS

Code Change No: **RM45-15**

Original Proposal

Section: M2101.10

Proponent: Michael Cudahy, representing Plastic Pipe and Fittings Association (mikec@cmservices.com)

Revise as follows:

M2101.10 Tests. Hydronic piping systems shall be tested hydrostatically at a pressure of one and one-half times the maximum system design pressure, but not less than 100 pounds per square inch (689 kPa). The duration of each test shall be not less than 15 minutes and not more than 20 minutes.

Exception: For PEX piping systems, testing with a compressed gas shall be an alternative to hydrostatic testing where compressed air or other gas pressure testing is specifically authorized by all of the manufacturer's instructions for the PEX pipe and fittings products installed at the time the system is being tested, and compressed air or other gas testing is not otherwise prohibited by applicable codes, laws, or regulations outside of this code.

Reason: PPFA has a new air testing policy, which allows for some limited air testing of plastic piping systems, if a number of conditions are met.

Bibliography: PLASTIC PIPE AND FITTINGS ASSOCIATION POLICY ON TESTING PLASTIC PIPE AND FITTINGS INSTALLATIONS WITH COMPRESSED GAS, PPFA, 2014, <http://www.ppfahome.org/ub4.aspx>
Compressed air or any other compressed gases should not be used for pressure testing plastic plumbing systems.

EXCEPTIONS:

- 1.) With trap seal pull testing, where a completed DWV system is vacuum tested with all of its traps filled with water, and the trap seals are tested with a vacuum typically between one and two inches of water column.
- 2.) For plastic piping systems specifically designed for use with compressed air or gasses;
 - Manufacturers' instructions must be strictly followed for installation, visual inspection, testing and use of the systems,
 - (and)
 - Compressed air or other gas testing is not prohibited by the authority having jurisdiction (AHJ).
- 3.) When compressed air or other gas pressure testing is specifically authorized by the applicable written instructions of the manufacturers of all plastic pipe and plastic pipe fittings products installed at the time the system is being tested and compressed air or other gas testing is not prohibited by the authority having jurisdiction (AHJ).

The manufacturer should be contacted if there is any doubt as to how a specific system should be tested.

Cost Impact: Will not increase the cost of construction

This proposal simply adds another option for air testing some specific piping materials into the code and as such, the option is not requiring that this method be chosen. Thus the code with this proposal added will not cause the cost of construction to increase.

Report of Committee Action Hearings

Committee Action:

Approved as Modified

Modify proposal as follows:

M2101.10 Tests. Hydronic piping systems shall be tested hydrostatically at a pressure of one and one-half times the maximum system design pressure, but not less than 100 pounds per square inch (689 kPa). The duration of each test shall be not less than 15 minutes and not more than 20 minutes.

Exception: For plastic-PEX piping systems, testing with a compressed gas shall be an alternative to hydrostatic testing where compressed air or other gas pressure testing is specifically authorized by all of the manufacturer's instructions for the plastic PEX pipe and fittings products installed at the time the system is being tested, and compressed air or other gas testing is not otherwise prohibited by applicable codes, laws, or regulations outside of this code.

Committee Reason: Approval was based on the proponent's published reason statements. The modification limits the exception to PEX because it is appropriate such material.

Assembly Action:

None

Final Action Results

RM45-15

AM

Code Change No: **RM47-15**

Original Proposal

Section: M2101.10

Proponent: Gary Morgan, Viega LLC, representing Viega LLC (gary.morgan@viega.us)

Revise as follows:

M2101.10 Tests. Hydronic piping systems shall be tested hydrostatically at a pressure of one and one-half times the maximum system design pressure, but not less than 100 pounds per square inch (689 kPa). The duration of each test shall be not less than 15 minutes ~~and not more than 20 minutes.~~

Reason: To limit the maximum time of pressure testing to 20 minutes (when the minimum time is already only 15 minutes) is not consistent with industry practice nor is it consistent with the IMC 1208.1 for testing of hydronic systems where no such maximum time even exists.

Cost Impact: Will not increase the cost of construction
Eliminating the maximum time of testing requirement has absolutely no bearing on the cost of construction.

Report of Committee Action Hearings

Committee Action:

Approved as Submitted

Committee Reason: Approval was based on the proponent's published reason statements.

Assembly Action:

None

Final Action Results

RM47-15

AS

Code Change No: **RM48-15**

Original Proposal

Section: M2103.2, M2103.2.1, M2103.2.2

Proponent: Brent Ursenbach, Salt Lake County, representing Utah Chapter ICC (bursenbach@slco.org)

Revise as follows:

M2103.2 Thermal barrier required. Radiant floor heating systems shall have a thermal barrier in accordance with Sections M2103.2.1 through M2103.2.4. Insulation R-values for slab-on-grade and suspended floor installations shall be in accordance with Chapter 11.

Exception: Insulation shall not be required in engineered systems where it can be demonstrated that the insulation will decrease the efficiency or have a negative effect on the installation.

Delete without substitution:

~~**M2103.2.1 Slab on grade installation.** Radiant piping used in slab on grade applications shall have insulating materials having a minimum R-value of 5 installed beneath the piping.~~

~~**M2103.2.2 Suspended floor installation.** In suspended floor applications, insulation shall be installed in the joist bay cavity serving the heating space above and shall consist of materials having a minimum R-value of 11.~~

Reason: Insulation R-values should be located in the IECC/Chapter 11, not Chapter 21- Hydronic Piping. Design professionals, code officials, contractors, developers, virtually all involved in the building process look to the IECC/Chapter 11 for specific thermal performance values. Locating these two sub-sections in the IMC has created considerable confusion. A similar proposal will be submitted in Group B, to add these sub-sections into the IECC where they belong.

Cost Impact: Will not increase the cost of construction

This proposal will not increase the cost of construction as it is the first step in re-locating an existing insulation requirement from the IRC mechanical section to the IECC/Chapter 11 IRC. There is no increase in the R-value of the insulation or the installation labor.

Report of Committee Action Hearings

Committee Action:

Approved as Modified

Modify proposal as follows:

M2103.2 Thermal barrier required. Radiant floor heating systems shall have a thermal barrier in accordance with Sections M2103.2.1 through M2103.2.4. Insulation R-values for slab-on-grade and suspended floor installations shall be in accordance with the International Energy Conservation Code Chapter 11.

Exception: Insulation shall not be required in engineered systems where it can be demonstrated that the insulation will decrease the efficiency or have a negative effect on the installation.

Committee Reason: Approval was based on the proponent's published reason statements. The modification keeps the text within the IRC for user convenience.

Assembly Action:

None

Final Action Results

RM48-15

AM

Code Change No: **RM51-15**

Original Proposal

Section: Table M2105.4, Table M2105.5

Proponent: Jeremy Brown, representing NSF International

Revise as follows:

**TABLE M2105.4
GROUND-SOURCE LOOP PIPE**

MATERIAL	STANDARD
Polypropylene (PP-R)	ASTM F 2389; CSA B137.11; <u>NSF 358-2</u>

(Portions of table not shown remain unchanged)

**TABLE M2105.5
GROUND-SOURCE LOOP PIPE FITTINGS**

PIPE MATERIAL	STANDARD
Polypropylene (PP-R)	ASTM F 2389; CSA B137.11; <u>NSF 358-2</u>

(Portions of table not shown remain unchanged)

Reference standards type:

Add new standard(s) as follows:

NSF 358-2-2012 Polypropylene Pipe & fittings for water-based ground-source "geothermal" heat pump systems

Reason: NSF 358-2 Polypropylene Pipe & fittings for water-based ground-source "geothermal" heat pump systems is the American National standard and should be included in these tables. This standard has requirements for material suitability, performance, chemical resistance long term strength and quality assurance requirements related to geothermal products. A copy of this standard will be provided to the committee and may be obtained by anyone else by emailing brown@nsf.org.

Cost Impact: Will not increase the cost of construction
Providing an additional option will not increase the cost of construction.

Analysis: A review of the standard proposed for inclusion in the code, NSF 358-2, with regard to the ICC criteria for referenced standards (Section 3.6 of CP#28) will be posted on the ICC website on or before April 2, 2015.

Report of Committee Action Hearings

Committee Action:

Approved as Submitted

Committee Reason: Approval was based on the proponent's published reason statements.

Assembly Action:

None

Final Action Results

RM51-15

AS

Code Change No: **RM52-15**

Original Proposal

Section: M2005.1, M2301.2.1, M2301.2.11.1, M2301.2.2.2, M2301.2.4, M2301.2.6, M2301.2.6.1 (New), M2301.2.6.2 (New), M2301.2.8, M2301.3, M2301.3.1, M2301.3.2.

Proponent: Rex Gillespie (rex.gillespie@caleffi.com)

Revise as follows:

M2005.1 General. Water heaters shall be installed in accordance with Chapter 28, the manufacturer's instructions and the requirements of this code. Water heaters installed in an attic shall comply with the requirements of Section M1305.1.3. Gas-fired water heaters shall comply with the requirements in Chapter 24. Domestic electric water heaters shall comply with UL 174. Oiled-fired water heaters shall comply with UL 732. ~~Thermal solar~~ Solar thermal water heaters heating systems shall comply with Chapter 23 and ~~UL 174~~ SRCC 300. Solid fuel-fired water heaters shall comply with UL 2523.

M2301.2.1 Access. ~~Solar energy collectors, controls, dampers, fans, blowers and pumps~~ Access shall be accessible provided to solar energy equipment for inspection, maintenance, repair. Solar systems and replacement appurtenances shall not obstruct or interfere with the operation of any doors, windows or other building components requiring operation or access. Roof-mounted solar thermal equipment shall not obstruct or interfere with the operation of roof-mounted equipment, appliances, chimneys, plumbing vents, roof hatches, smoke vents, skylights and other roof penetrations and openings.

M2301.2.2.2 Collector sensors. Collector sensor installation, sensor location and the protection of exposed sensor wires from ~~ultraviolet light degradation~~ shall be in accordance with SRCC 300.

M2301.2.4 Vacuum relief. System components that might be subjected to ~~pressure drops below atmospheric pressure~~ a vacuum during operation or shutdown shall be designed to withstand such vacuum or shall be protected by a vacuum relief valve with vacuum relief valves.

M2301.2.6 Protection from freezing. System components shall be protected from damage resulting from freezing of heat-transfer liquids at the winter design temperature provided in Table R301.2(1). Freeze protection shall be provided ~~by heating, insulation, thermal mass and heat transfer fluids in~~ accordance with SRCC 300. Drain-back systems shall be installed in compliance with Section M2301.2.6.1 and systems utilizing freeze points lower than the winter design temperature, heat tape or other approved methods, or combinations thereof protection valves shall comply with Section M2301.2.6.2.

Exception: Where the 97.5-percent winter design temperature is greater than ~~32~~ or equal to 48°F (9°C).

M2301.2.8 Expansion tanks. Expansion tanks in solar energy systems shall be installed in accordance with Section M2003 in solar collector loops that contain pressurized heat transfer fluid. Where expansion tanks are used, the system shall be designed in accordance with SRCC 300 to provide an expansion tank that is sized to withstand the maximum operating pressure of the system.

Exception: Expansion tanks shall not be required in the collector loop of drain-back systems.

M2301.2.11.1 Solar loop isolation. Valves shall be installed to allow the solar ~~collectors loop~~ to be isolated from the remainder of the system

M2301.3 Labeling. *Labeling* shall comply with Sections M2301.3.1 and M2301.3.2.

M2301.3.1 Collectors and panels. Solar thermal collectors and panels shall be listed and labeled in accordance with SRCC 100 or SRCC 600. ~~Collectors and panels~~ Factory-built collectors shall ~~be listed and labeled to show~~ bear a label showing the manufacturer's name, model number, and serial number, collector weight, collector maximum allowable temperatures and pressures, and the type of heat transfer fluids that are compatible with the collector or panel. ~~The label shall clarify that these specifications apply only to the collector or panel.~~

M2301.3.2 Thermal storage units. Pressurized ~~thermal water storage units tanks~~ shall ~~be listed and labeled to show~~ bear a label showing the manufacturer's name and address, model number, serial number, storage unit maximum and minimum allowable operating temperatures and pressures, storage unit maximum and the type of heat transfer fluids that are compatible with the storage unit minimum allowable operating pressures. The *label* shall clarify that these specifications apply only to the ~~thermal water storage unit tanks~~.

Add new text as follows:

M2301.2.6.1 Drain-back systems Drain-back systems shall be designed and installed to allow for manual gravity draining of fluids from areas subject to freezing to locations not subject to freezing, and air filling of the components and piping. Such piping and components shall maintain a horizontal slope in the direction of flow of not less than one-fourth unit vertical in 12 units horizontal (2-percent slope). Piping and components subject to manual gravity draining shall permit subsequent air filling upon drainage and air venting upon refilling.

M2301.2.6.2 Freeze protection valves. Freeze protection valves shall discharge in a manner that does not create a hazard or structural damage.

Reason: A reference to the SRCC 300 standard was added to the IRC in Chapter 23 during the 2015 cycle. This change in Chapter 20 changes to language to correspond to SRCC 300. Requirements for hot water storage tanks, which UL 174 intended to address are covered in SRCC 300, therefore, UL 174 is no longer necessary.

Access provisions were revised to clarify that roof-mounted solar collectors and equipment should not interfere with the operation of key safety components and features from other systems. While this can reasonably assumed, providing this provisions will provide code officials more clear language to reference when inspecting installations.

New language has been added to the freeze protection section to address specific issues with two of the most common freeze protection approaches: drainback systems and freeze protection valves. Drainback systems allow the liquid to drain from the external collector to conditioned space when flow is not occurring. As a result proper slope is critical to ensure operation.

Inspection of the installation and workmanship is necessary to ensure that the slope is consistent and the freeze protection is fully functional. Freeze protection valves discharge a small amount of water in freezing conditions and therefore should be addressed in a way similar to T&P valves to ensure that the discharge does not damage the roof or create a hazard (e.g. freezing on a pedestrian walkway). Identical language has also been proposed for Chapter 14 of the IMC. The winter design temperature was revised to utilize the 97.5% winter design temperature, which can be found in Appendix D of the IPC. The threshold value was adjusted to accommodate this change. This will provide greater clarity and allow the Appendix D tables to be used.

The provisions relating to collector and hot water storage tank labeling were simplified since this information and more can be found in manuals and specifications. The language for storage units (tanks) was also revised to clarify that they are only to apply to hot water storage tanks.

Bibliography: SRCC 300, Minimum Standards for Solar Water Heating Systems, Jan. 2, 2013.

Cost Impact: Will not increase the cost of construction

The proposed changes are not anticipated to impact the cost of installation. No new equipment or features are required, and no new requirements are placed on manufacturers impacting certification or manufacturing costs. Proposed provisions provide additional clarity and direction for installers and code officials at inspection.

**Report of Committee Action
Hearings**

Committee Action:

Approved as Submitted

Committee Reason: Approval was based on the proponent's published reason statements.

Assembly Action:

None

Final Action Results

RM52-15

AS

Code Change No: **RP5-15**

Original Proposal

Section: P2801.6

Proponent: Kari Hebrank, Wilson & Associates, representing VizCO-US (khebrank@wilsonmgmt.com)

Revise as follows:

P2801.6 Required pan. Where a storage tank-type water heater or a hot water storage tank is installed in a location where water leakage from the tank will cause damage, the tank shall be installed in a pan constructed of one of the following:

1. Galvanized steel or aluminum of not less than 0.0236 inch (0.6010 mm) in thickness.
2. Plastic not less than 0.036 inch (0.9 mm) in thickness.
3. Other approved materials.

A plastic pan shall not be installed beneath a gas-fired water heater shall be constructed of material having a flame spread index of 25 or less and a smoke-developed index of 450 or less when tested in accordance with ASTM E 84 or UL 723.

Reason: The reason for this code proposal is that there should not be a restriction against the installation of all plastic pans beneath gas-fired hot water heaters and storage tanks as there are some plastic pans that have been developed and successfully tested against tough industry standards and ratings for flammability and smoke, specifically ASTM E84 Class A standards, thus making these type of pans perfectly suitable for water leakage protection for gas-fired hot water heaters.

One such product is manufactured by VizCO-US, Inc., and their proprietary SECUREFLX material, which was tested and met both UL94 V2 flammability rating and ASTM E84 Class A standards for flame spread and smoke development, has been used and approved in furnace drain pans for years. The heat and distortion thresholds of this material and the accompanying proven test and rating standards make VizCO-US pans an extremely safe product for use with either gas or electric water heaters. The VizCO-US product test reports are included in an attachment to this code proposal {510} {509} and it is important to note that the UL94 flammability rating for plastic materials --to which the VizCO-US plastic pan adheres--states that specimens may not burn with flaming combustion for more than 30 seconds after either application of the test flame.

Another reason for this code change is that without it, there would be a restriction of trade for manufacturers who produce plastic drip pans that meet the mandated UL and ASTM standards for flammability and smoke. Furthermore, the building code is intended to accommodate new products and new technology as innovative ideas and products emerge, rather than discriminate against products that meet current industry building standards. Without this code change, there will be discrimination against one segment of the building product manufacturing industry.

Moreover, with ZERO CLEARANCE gas water heater models, the manufacturers have approved a zero clearance between the bottom of the tank and any flammable surface, so a plastic pan that meets flammability ratings should be allowed upon the manufacturers approval.

Without this code change, only metal pans would be allowed to be installed beneath a gas-fired water heater, thus limiting choice for both the contractor and the consumer, and ultimately increasing costs. VizCO-US plastic pans meet or exceed ASTM E-84 and UL 94 testing and performance standards and contain the following characteristics: self-extinguishing, low smoke, flexible, extreme strength, affordability and perform without failure at a higher temperature range than any other non-metallic solution. (See sales sheet attachment for product characteristics.) {511} {512}

The standards UL 723 and ASTM 84 are standards that characterize the relative rate at which flame will spread as the subject material burns. Testing reports for the VizCO-US plastic pans are attached to this code proposal.



SECUREFLX material



VizCO Corporate office in Bradenton, Florida.



Extrusion line at the Monticello, Florida factory.

SecureFLX is designed to be safer and physically outperform every other drain pan at a superior price point.

Our goal is to provide a product with the following characteristics: self extinguishing, low smoke, flexibility, extreme strength and to perform without failure at a higher temperature range than any other non-metallic solution.

The result is a cost effective material unlike anything on the market.

Independent laboratories have tested and rated our material to meet or exceed ASTM E-84 class A and UL-94 testing and performance standards.

Meets or Exceeds

Meets ASTM E84 class A rating.

ASTM E 84 - CLASS A RATING:

	Flame Spread Index	Smoke Developed Index
Class A	0-25	0-450

Material Properties

PROPERTIES	ASTM METHOD	VALUE
Izod Impact	D-256	12.0 ft-lbs/in
Tensile Strength	D-638	8,900 psi
Flexural Strength	D-790	13,500 psi
Flexural Modulus	D-790	345,000 psi
Rockwell Hardness	D-785	112 R
HDTUL Unannealed (264 psi)	D-648	270°F

USED BY CODE OFFICIALS AND REGULATORY AGENCIES IN THE ACCEPTANCE OF INTERIOR FINISH MATERIALS FOR VARIOUS APPLICATIONS.

THE MOST WIDELY ACCEPTED CLASSIFICATION SYSTEM DESCRIBED IN THE NATIONAL FIRE PROTECTION ASSOCIATION PUBLICATION NFPA 101 LIFE SAFETY CODE. CHARACTERIZES THE RELATIVE RATE AT WHICH FLAME WILL SPREAD AS THE SUBJECT MATERIAL BURNS.

Mechanical Properties

- TEMPERATURE RANGE: -20°F TO 260°F
- DISTORTION TEMPERATURE: 310°F
- LOAD SUPPORT (LBS): 1000+
- FLAME RETARDANT
- SELF-EXTINGUISHING
- LOW SMOKE



UL94 FLAMMABILITY RATING:

SPECIMENS MAY NOT BURN WITH FLAMING COMBUSTION FOR MORE THAN 30 SECONDS AFTER EITHER APPLICATION OF THE TEST FLAME.

THE STANDARD FOR SAFETY OF FLAMMABILITY OF PLASTIC MATERIALS

SECUREFLX

www.VizCo.com • (941) 753-3333
3500 9th Street West • Bradenton, FL 34205

Bibliography: The referenced testing standards and ratings are included in the attachments. {509} {510}

Cost Impact: Will not increase the cost of construction

This code proposal has cost-savings implications to the construction industry and consumers. VizCO-US plastic pans will save distributors, contractors and homeowners anywhere from 10%-30% when installed beneath gas-fired water heaters, rather than installation of the higher-priced metal pans. Additionally, oftentimes there are replacement costs with the metal pans, especially the flimsier aluminum pans, that are easily dented and crushed during transportation from the manufacturer to the distributor, from the distributor to the contractor and from the contractor to the jobsite.

Unlike metal pans which are dented and crushed during installation of the water tanks that roll over the sides of the pan, VizCO-US plastic pans are designed not to break, crack, split or crush. You can actually roll a tank over the side of a VizCO-US pan which is designed to aide in the installation process and keep the contractor from having to lift a tank up and over a sidewall of the pan. (See sales sheet attachment for product description.) {511} {512}

VizCO-US pans offer cost-savings to everyone in the supply chain from the time it is released from the manufacturing plant until the time the tank is set in place. Due to the extreme strength of the product, there are cost-savings in shipping/delivery costs and financial cost-savings by not having to worry about replacement costs, or credits and returns for damaged products like there are with metal pans.

Report of Committee Action Hearings
--

Committee Action:

Approved as Submitted

Committee Reason: The committee agreed with the proponent's published reason statement.

Assembly Action:

None

Final Action Results

RP5-15

AS

Code Change No: **RP8-15**

Original Proposal

Section: P2902.5.4, P2904.1.

Proponent: Jeffrey Shapiro, representing International Residential Code Fire Sprinkler Coalition (jshapiro@ircfiresprinkler.org)

Revise as follows:

P2902.5.4 Connections to automatic fire sprinkler systems. The potable water supply to automatic fire sprinkler systems shall be protected against backflow by a double check backflow prevention assembly, a double check fire protection backflow prevention assembly, a reduced pressure principle backflow prevention assembly or a reduced pressure principle fire protection backflow prevention assembly.

~~**Exception:** Where systems are installed as a portion of the water distribution system in accordance with the requirements of this code and are not provided with a fire department connection, backflow protection for the water supply system shall not be required.~~

Exception: Where sprinkler systems are installed in accordance with Section P2904.1, backflow protection for the water supply system shall not be required.

P2904.1 General. The design and installation of residential fire sprinkler systems shall be in accordance with NFPA 13D or Section P2904, which shall be considered equivalent to NFPA 13D. Partial residential sprinkler systems shall be permitted to be installed only in buildings not required to be equipped with a residential sprinkler system. Section P2904 shall apply to stand-alone and multipurpose wet-pipe sprinkler systems that do not include the use of antifreeze. A multipurpose fire sprinkler system shall provide domestic water to both fire sprinklers and plumbing fixtures. A stand-alone sprinkler system shall be separate and independent from the water distribution system.

A backflow preventer shall not be required to separate a ~~stand-alone~~ sprinkler system from the water distribution system, provided that the sprinkler system complies with all of the following:

1. The system complies with NFPA 13D or Section P2904.
2. The piping material complies with Section P2905.
3. The system does not contain antifreeze.
4. The system does not have a fire department connection.

Reason: The proposed revision clarifies the code by coordinating the requirements in Sections P2902.5.4 with P2904.1. The allowance to omit backflow protection for certain stand-alone systems currently permitted by Section P2904.1 was not previously correlated with Section P2902.5.4, which has caused confusion in applying the code. The proposed text further improves usability of the code by placing a complete backflow preventer exception in Section P2904.1 rather than the current approach, which covers multipurpose systems in Section P2902.5.4 and standalone systems in Section P2904.1.

The proposed revision also makes it clear that the permissible exception to backflow protection applies to systems installed to either Section P2904 or NFPA 13D, and it corrects an oversight in the current code text related to fire department connections, making it clear that backflow protection may not be omitted on any system, stand-alone or multipurpose, that is provided with a fire department connection. Although fire department connections aren't required by Section P2904 and aren't ordinarily installed on home fire sprinkler systems, the possibility that such a connection might be voluntarily provided must be addressed.

Cost Impact: Will not increase the cost of construction

The proposal will reduce the cost of construction in cases where a backflow preventer would otherwise have been provided because of a misunderstanding of the current code provisions.

**Report of Committee Action
Hearings**

Committee Action:

Approved as Submitted

Committee Reason: The committee agreed with the proponent's published reason statement.

Assembly Action:

None

Final Action Results

RP8-15

AS

Code Change No: **RP10-15**

Original Proposal

Section: P2903.5

Proponent: Michael Meagher, representing Sioux Chief Mfg (michael.meagher@siouxchief.com)

Revise as follows:

P2903.5 Water hammer. The flow velocity of the water distribution system shall be controlled to reduce the possibility of water hammer. A water hammer arrestor shall be installed where quick-closing valves are utilized. Water-hammer arrestors shall be installed in accordance with the manufacturer's instructions. Water-hammer arrestors shall conform to ASSE 1010.

Reason: This proposal re-aligns both the IRC P2903.5 with the IPC 604.9 Water Hammer paragraphs as they were when they were first created, eliminating confusion and clearly spelling out the necessary requirement for water hammer control on all plumbing systems. Originally, these two code paragraphs on water hammer control were identical. Then, the 2009 IRC P2903.5 was edited, striking a single sentence that contained the mandatory language. This same edit proposal did not make it through to the 2009 IPC 604.9. It was voted down, keeping the mandatory language as is. Confusion amongst code officials throughout the country has ensued over this discrepancy in the two codes ever since.

Water hammer control has been a part of our plumbing codes and practices ever since plain air chambers were introduced over a hundred years ago. Today, modern plumbing systems require water hammer control even more so than in the past. In regards to the science of water hammer, the laws of physics do not change when comparing the pressure surge in a 1-or-2 family dwelling to the surge in a multi-family system. They are the same. In addition, the advent of plastic piping systems, with various designs of metal and hard-plastic mechanical fitting systems, do not eliminate this need for water hammer control, as some may have assumed. Rather, the need to protect these systems from damaging pressure surges is even greater due to their lower pressure ratings compared to traditional metal piping systems.

Over the years, the plumbing industry has developed a wide variety of ASSE 1010 certified AA size arresters, even laundry boxes with certified integral arresters, which have become very popular throughout the country, making water hammer control very easy and affordable. Other model codes requiring arresters have been successfully welcomed and easily enforced throughout much of the United States, Canada, and in many parts of the world, for many years now. The installation of AA arresters is now common practice for well over half the residential construction in North America, in both single-family and multi-family.

Bibliography: [Link to website for additional information] This link to the ASSE website verifies the many arrester manufacturers and the wide variety of ASSE certified AA arrester options available in the plumbing industry.
http://www.asse-plumbing.org/prodlist_new.asp

Cost Impact: Will increase the cost of construction

For the tens of thousands of new homes that are already being installed with AA arresters, there is NO cost impact.

For the tens of thousands of new homes that are still being installed with old-fashioned plain air chambers, there is NO cost impact, and more likely a cost savings, due to the elimination of the cost of labor and material of installing 12-16 air chambers versus the cost of 3 to 5 AA arresters per home.

Where the current IRC is being used and interpreted as requiring NO water hammer control, the initial installation cost impact of this code change will be roughly \$18 to \$30 per home, depending on local interpretation of required quick-closing valves. This cost impact is calculated using the most common practice of arrester installation, which is installing outlet boxes (such as laundry boxes) with integral arresters. Since the arresters are already factory-installed, the cost impact is simply the cost difference in boxes with and without arresters, roughly \$6 per single valve/arrester box (\$12 per laundry box since it includes two arresters per box). The second most popular AA arrester installation is the swivel compression tee arrester which easily and quickly hooks up to the compression supply stop that serves the quick-closing valve. The cost impact of this is roughly \$8. Depending on local enforcement, the total cost impact per home could be \$18-\$30, or an average of about \$24 per home.

The LONG TERM cost impact of water hammer control, however, is immeasurable. yet very obvious. Just like many other required devices in a plumbing system, such as pressure reducing valves limiting static pressures to 80 psi, water hammer arresters will help protect the entire plumbing system and all of its necessary appurtenances and appliances from premature failure, saving the homeowner thousands of dollars in repairs and damage over the life of the home.

**Report of Committee Action
Hearings**

Committee Action:

Approved as Submitted

Committee Reason: The committee agreed with the proponent's published reason statement.

Assembly Action:

None

Final Action Results

RP10-15

AS

Code Change No: **RP12-15**

Original Proposal

Section: Table P2906.6, Chapter 44

Proponent: William Chapin, representing Professional Code Consulting, LLC (bill@profcc.us)

Revise as follows:

**TABLE P2906.6
PIPE FITTINGS**

MATERIAL	STANDARD
Fittings for polyethylene of raised temperature (PE-RT) plastic tubing	ASSE 1061; ASTM F 1807; ASTM F2098; ASTM F 2159; ASTM F 2735; ASTM F 2769

(Portions of table not shown remain unchanged)

Reference standards type:

Add new standard(s) as follows:

ASSE 1061-2011 Performance Requirements for Push-Fit Fittings (UPDATE of edition year).

Reason: ASSE 1061-2011 added PE-RT to the list of tubing that can be used with the fittings.

Cost Impact: Will not increase the cost of construction

This will not increase the cost of construction as it only adds another option for the installer.

Analysis: Successful action on this proposal will result in the update of Reference Standard ASSE 1061 to the 2011 edition level for only the change indicated in the table. A coordinating proposal for updating the standard for the entire code will be submitted to Group B for inclusion in the Reference Standards administrative update proposal.

Report of Committee Action Hearings

Committee Action:

Approved as Submitted

Committee Reason: The committee agreed with the proponent's published reason statement.

Assembly Action:

None

Final Action Results

RP12-15

AS

Code Change No: **RP13-15**

Original Proposal

Section: P2906.6.1 (New)

Proponent: Janine Snyder, representing Plumbing, Mechanical, and Fuel Gas Code Action Committee (PMGCAC@iccsafe.org) William Chapin, representing Professional Code Consulting, LLC (bill@profcc.us)

Add new text as follows:

P2906.6.1 Saddle tap fittings. The use of saddle tap fittings and combination saddle tap and valve fittings shall be prohibited.

Reason: As PEX, PE-RT and CPVC tubings are becoming even more popular than ever for water distribution systems in residential buildings, there are more reports of saddle tap fittings being installed on these types of tubing. This just doesn't work out very well. The IRC does not require that refrigerator ice maker water supply connection boxes be installed at rough-in. And the installation of reverse osmosis drinking water systems is becoming quite popular. Where can someone tap into the water distribution system for the supply of water? A saddle tap is quick and easy but is subject to being bumped and twisted. Where the tap is a combination tap and valve, operation of the valve makes the potential for leakage problems greater.

This connection method should be prohibited just like it has been prohibited in the IPC for some time.

This proposal is submitted by the ICC Plumbing, Mechanical and Fuel Gas Code Action Committee (PMGCAC) The PMGCAC was established by the ICC Board of Directors to pursue opportunities to improve and enhance assigned International Codes or portions thereof. This includes both the technical aspects of the codes and the code content in terms of scope and application of referenced standards. The PMGCAC has held one open meeting and multiple conference calls which included members of the PMGCAC. Interested parties also participated in all conference calls to discuss and debate the proposed changes. This is PMGCAC Item 130.

Cost Impact: Will increase the cost of construction

This proposal will increase the cost of construction because additional labor, materials, equipment, appliances or devices are mandated beyond what is currently required by the code. For those plumbing contractors that were trying to legally cut corners in every way possible, there will be the minor added cost for a tee installation. Can they convince the builder or developer that they should be paid more for their work because of this change? It would be very, very doubtful that the builder or developer will be impacted with this minor cost addition.

Report of Committee Action Hearings

Committee Action:

Approved as Submitted

Committee Reason: The committee agreed with the proponent's published reason statement.

Assembly Action:

None

Final Action Results

RP13-15

AS

Code Change No: **RP14-15**

Original Proposal

Section: P2906.9.1.5, P2906.9.1.5.1, P2906.9.1.5.2

Proponent: Gary Morgan, Viega.LLC, representing Viega LLC (gary.morgan@viega.us)

Revise as follows:

~~P2906.9.1.5~~ **P2906.10 Cross-linked polyethylene plastic (PEX).** Joints between cross-linked polyethylene plastic tubing or fittings shall comply with Section ~~P2906.9.1.5.1~~ P2906.10.1 or Section ~~P2906.9.1.5.2~~ P2906.10.2.

~~P2906.9.1.5.1~~ **P2906.10.1 Flared joints.** *No change to text.*

~~P2906.9.1.5.2~~ **P2906.10.2 Mechanical joints.** Mechanical joints shall be installed in accordance with the manufacturer's instructions. Fittings for cross-linked polyethylene (PEX) plastic tubing shall comply with the applicable standards indicated in Table P2906.6 and shall be installed in accordance with the manufacturer's instructions. PEX tubing shall be factory marked with the applicable standards for the fittings that the PEX manufacturer specifies for use with the tubing.

Reason: This proposal fixes an oversight that has existed for several years in this code in that the Section for "PEX Plastic" (P2906.9.1.5) should never have been subcategorized under "Solvent cementing" Section P2906.9.1. Like other specific piping material types, "PEX plastic" should have had it's own section like that of Polypropylene (PP), PEX/AL/PEX, Stainless Steel, Press-connect, and PE-RT to name a few.

This proposal also brings the IRC in consistent alignment with how the IPC is now organized by renumbering the sections for PEX.

Cost Impact: Will not increase the cost of construction

This proposal will have no effect on the cost of construction and only seeks to correct an oversight of organizational numbering.

Report of Committee Action Hearings

Committee Action:

Approved as Submitted

Committee Reason: The committee agreed with the proponent's published reason statement.

Assembly Action:

None

Final Action Results

RP14-15

AS

Code Change No: **RP15-15**

Original Proposal

Section: P2906.9.1.4

Proponent: Tim Earl, GBH International, representing The Oatey Company, representing The Oatey Company (tearl@gbhinternational.com)

Revise as follows:

~~P2906.9.1.5~~ P2906.10 Cross-linked polyethylene plastic (PEX). Joints between cross-linked polyethylene plastic tubing or fittings shall comply with Section ~~P2906.9.1.5.1~~ P2906.10.1 or Section ~~P2906.9.1.5.2~~ P2906.10.2.

~~P2906.9.1.5.1~~ P2906.10.1 Flared joints. *No change to text.*

~~P2906.9.1.5.2~~ P2906.10.2 Mechanical joints. Mechanical joints shall be installed in accordance with the manufacturer's instructions. Fittings for cross-linked polyethylene (PEX) plastic tubing shall comply with the applicable standards indicated in Table P2906.6 and shall be installed in accordance with the manufacturer's instructions. PEX tubing shall be factory marked with the applicable standards for the fittings that the PEX manufacturer specifies for use with the tubing.

Reason: This proposal fixes an oversight that has existed for several years in this code in that the Section for "PEX Plastic" (P2906.9.1.5) should never have been subcategorized under "Solvent cementing" Section P2906.9.1. Like other specific piping material types, "PEX plastic" should have had it's own section like that of Polypropylene (PP), PEX/AL/PEX, Stainless Steel, Press-connect, and PE-RT to name a few.

This proposal also brings the IRC in consistent alignment with how the IPC is now organized by renumbering the sections for PEX.

Cost Impact: Will not increase the cost of construction

This proposal will have no effect on the cost of construction and only seeks to correct an oversight of organizational numbering.

Report of Committee Action Hearings

Committee Action:

Approved as Submitted

Committee Reason: The committee agreed with the proponent's published reason statement.

Assembly Action:

None

Final Action Results

RP15-15

AS

Code Change No: **RP16-15**

Original Proposal

Section: Table P2906.4, Table P2906.5, Table P2906.6, P2906.19, P2906.19.2 (New), P2906.19.3 (New)

Proponent: Tim Earl, GBH International, representing The Oatey Company, representing The Oatey Company (tearl@gbhinternational.com)

Revise as follows:

**TABLE P2906.4
WATER SERVICE PIPE**

MATERIAL	STANDARD
Polyethylene of raised temperature (PE-RT) plastic tubing	ASTM F 2769; <u>CSA B137.18</u>

(Portions of table not shown remain unchanged)

**TABLE P2906.5
WATER DISTRIBUTION PIPE**

MATERIAL	STANDARD
Polyethylene of raised temperature (PE-RT) plastic tubing	ASTM F 2769; <u>CSA B137.18</u>

(Portions of table not shown remain unchanged)

**TABLE P2906.6
PIPE FITTINGS**

MATERIAL	STANDARD
Fittings for polyethylene of raised temperature (PE-RT) plastic tubing	ASTM F 1807; ASTM F2098; ASTM F 2159; ASTM F 2735; ASTM F 2769; <u>ASTM F1055;</u> ASTM D2683; ASTM D3261; <u>CSA B137.18</u>

(Portions of table not shown remain unchanged)

P2906.19 Polyethylene of raised temperature plastic. Joints between polyethylene of raised temperature plastic tubing and fittings shall be in accordance with ~~Section~~ Sections P2906.19.1, P2906.19.2 and P2906.19.3.

Add new text as follows:

P2906.19.2 Heat fusion Joints Joints shall be of the socket-fusion, saddle-fusion, or butt-fusion type, and shall be joined in accordance with ASTM D2657. Joint surfaces shall be clean and free of moisture. Joint surfaces shall be heated to melt temperatures and joined. The joint shall remain undisturbed until cool. Fittings shall be manufactured in accordance with ASTM D2683 or ASTM D3261.

P2906.19.3 Electrofusion Joints Joints shall be of the electrofusion type. Joint surfaces shall be clean and free of moisture and scoured to expose virgin resin. Joint surfaces shall be heated to melt temperatures for a period of time specified by the manufacturer and joined. The joint shall remain undisturbed until cool. Fittings shall be manufactured in accordance with ASTM F1055.

**Reference standards type:
Add new standard(s) as follows:**

CSA B137.18 - 2013 - Polyethylene of raised temperature resistance (PE-RT) tubing systems for pressure applications.

Reason: Add new CSA B137.18 Polyethylene of raised temperature resistance (PE-RT) tubing systems for pressure applications to tables P2906.4, P2906.5 and P2906.6. This standard includes both pipe and fittings for water service and water distribution. This change will permit pipe and fittings meeting CSA B137.18 to be used in accordance with the Code.

Add new sections P2906.19.2 and P2906.19.3 for PE-RT fusion joints. Also add corresponding reference standards for PE-RT fusion - ASTM F1055, ASTM D2683 and ASTM D3261. This change will permit PE-RT pipe to be joined by fusing methods.

Cost Impact: Will not increase the cost of construction

This proposal adds additional standards for use with PERT pipe and fittings. These new standards are similar to existing referenced standards and product are similar so there is no increase in the cost of the PERT system by referencing these standards and adding standards to permit fusion of PERT.

Analysis: A review of the standard proposed for inclusion in the code, CSA B137.18 - 2013, with regard to the ICC criteria for referenced standards (Section 3.6 of CP#28) will be posted on the ICC website on or before April 2, 2015.

Report of Committee Action Hearings
--

Committee Action:

Approved as Submitted

Committee Reason: More options for pipe and joints provides for greater flexibility.

Assembly Action:

None

Final Action Results

RP16-15

AS

Code Change No: **RP17-15**

Original Proposal

Section: P3003.9.2

Proponent: Tim Earl, GBH International (tearl@gbhinternational.com)

Revise as follows:

P3003.9.2 Solvent cementing. Joint surfaces shall be clean and free from moisture. A purple primer, or other approved primer, that conforms to ASTM F 656 shall be applied. Solvent cement not purple in color and conforming to ASTM D 2564, CSA B137.3 or CSA B181.2 shall be applied to all joint surfaces. The joint shall be made while the cement is wet, and shall be in accordance with ASTM D 2855. Solvent-cement joints shall be installed above or below ground.

Exception: A primer shall not be required where all of the following conditions apply:

1. The solvent cement used is third-party certified as conforming to ASTM D 2564.
2. The solvent cement is used only for joining PVC drain, waste and vent pipe and fittings in non-pressure applications in sizes up to and including 4 inches (102 mm) in diameter.

Reason: The market place has already begun using clear as well as UV-light visible primers where local inspectors allow. Many users prefer this as spilled purple primers can permanently stain surfaces and cause added expenses in repair/replacement of stained items. Also, there are some installations (under sinks, basements) where the PVC will be exposed and the primer visible after installation. This simply meets a market condition and gives broader authority for these applications to occur. This would also be consistent with language in the IPC and other proposals in the IRC.

Visible primer stains on pipe installation:

[Typical installation with visible primer](#)

[UV-visible primer:](#)

[UV visible primer](#)

Staining to floor from purple primer (after being wiped off, with less than one minute of exposure):

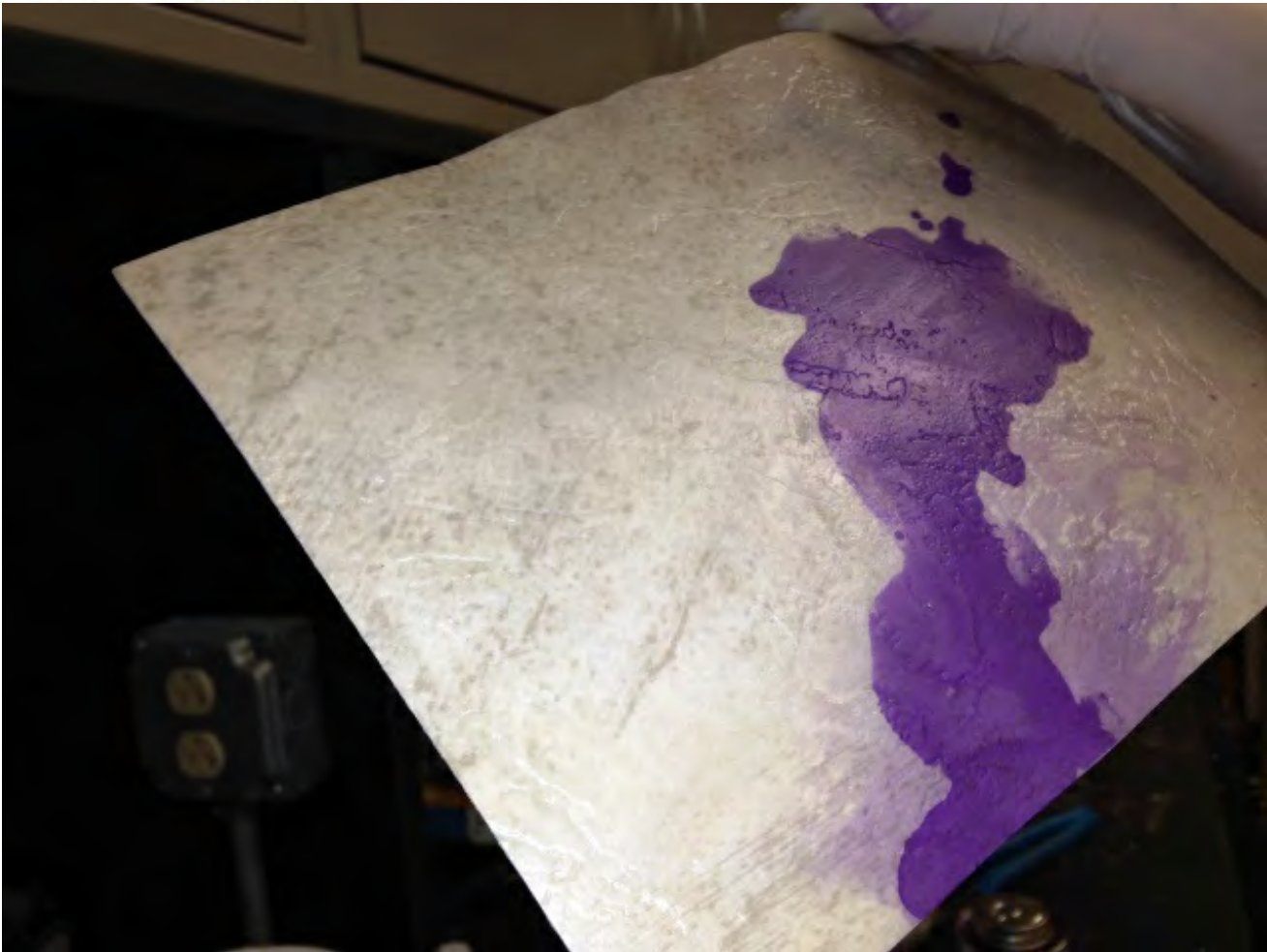
[Stained floor](#)

[Stained tile](#)





Inspector can verify the use of Primer with a UV flashlight.





Cost Impact: Will not increase the cost of construction
This proposal will not impact cost as it simply allows another primer option.

Report of Committee Action Hearings

Committee Action: **Approved as Submitted**

Committee Reason: The committee agreed with the proponent's published reason statement.

Assembly Action: **None**

Final Action Results

RP17-15 **AS**

[←BACK](#)

Code Change No: **RB218-16**

Original Proposal

Section: R602.3(6) (New), R602.3.1

Proponent: Gary Ehrlich, National Association of Home Builders, representing National Association of Home Builders (gehrlich@nahb.org)

Revise as follow:

R602.3.1 Stud size, height and spacing. The size, height and spacing of studs shall be in accordance with Table R602.3(5).

Exceptions:

1. Utility grade studs shall not be spaced more than 16 inches (406 mm) on center, shall not support more than a roof and ceiling, and shall not exceed 8 feet (2438 mm) in height for exterior walls and load-bearing walls or 10 feet (3048 mm) for interior nonload-bearing walls.
2. Where snow loads are less than or equal to 25 pounds per square foot (1.2 kPa), and the ultimate design wind speed is less than or equal to 130 mph (58.1 m/s), 2-inch by 6-inch (38 mm by 14 mm) studs supporting a roof load with not more than 6 feet (1829 mm) of tributary length shall have a maximum height of 18 feet (5486 mm) where spaced at 16 inches (406 mm) on center, or 20 feet (6096 mm) where spaced at 12 inches (304.8 mm) on center. Studs shall be minimum No. 2 grade lumber.
3. Exterior load-bearing studs not exceeding 12 feet (3658 mm) in height provided in accordance with Table R602.3(6). The minimum number of full-height studs adjacent to openings shall be in accordance with Section R602.7.5. The building shall be located in Exposure B, the roof live load shall not exceed 20 psf (0.96 kPa), and the ground snow load shall not exceed 30 psf (1.4 kPa). Studs and plates shall be #2 grade lumber or better.

Add new table as follows:

TABLE R602.3(6)
ALTERNATE WOOD BEARING WALL STUD SIZE, HEIGHT AND SPACING

Stud Height	Supporting	Stud Spacing ^a	Ultimate Design Wind Speed					
			115 mph		130 mph ^b		140 mph ^b	
			Roof/Floor Span		Roof/Floor Span		Roof/Floor Span	
			12 ft.	24 ft.	12 ft.	24 ft.	12 ft.	24 ft.
11 ft.	Roof Only	12 in.	2x4	2x4	2x4	2x4	2x4	2x4
		16 in.	2x4	2x4	2x4	2x6	2x4	2x6
		24 in.	2x6	2x6	2x6	2x6	2x6	2x6
	Roof and One Floor	12 in.	2x4	2x6	2x4	2x6	2x4	2x6
		16 in.	2x6	2x6	2x6	2x6	2x6	2x6
		24 in.	2x6	2x6	2x6	2x6	2x6	2x6
12 ft.	Roof Only	12 in.	2x4	2x4	2x4	2x6	2x4	2x6
		16 in.	2x4	2x6	2x6	2x6	2x6	2x6
		24 in.	2x6	2x6	2x6	2x6	2x6	2x6
	Roof and One Floor	12 in.	2x4	2x6	2x6	2x6	2x6	2x6
		16 in.	2x6	2x6	2x6	2x6	2x6	2x6
		24 in.	2x6	2x6	2x6	2x6	2x6	2x6

		16 in.	2x6	2x6	2x6	2x6	2x6	2x6
		24 in.	2x6	2x6	2x6	2x6	2x6	DR

For SI: 1 inch = 25.4mm, 1 foot = 304.8 mm, 1 mph = 0.447 m/s

DR = Design Required

- a. Wall studs not exceeding 16 in. on center shall be sheathed with minimum 1/2" (12/7 mm) gypsum board on the interior and 3/8" (9 mm) wood structural panel sheathing on the exterior. Wood structural panel sheathing shall be attached with 8d (2.5" x 0.131") nails spaced a maximum of 6" on center along panel edges and 12" on center at intermediate supports, and all panel joints shall occur over studs or blocking.
- b. Where the ultimate design wind speed exceeds 115 mph, studs shall be attached to top and bottom plates with connectors having a minimum 300 pound (136 kg) capacity.

Reason: The purpose of this code change is to introduce a new table for load-bearing studs over 10 feet in height but not exceeding 12 feet in height. Previous to the 2015 edition, the IRC provided Table R602.3.1 allowing exterior load-bearing studs up to 20 feet in height for a limited set of conditions. In the 2015 IRC, the table was removed and converted into Exception #2 under Section R602.3.1.

One of the main reasons the table was removed was that builders and building officials did not understand where the table applied based on the limitations. Also, the allowable stud sizes in the table dated back to the CABO code, when there were actually three tables which were subsequently combined into Table R602.3.1 in the 2000 IRC. No technical substantiation for the allowable stud sizes in the old table could be located.

This table was constructed using the exterior wall stud bending stresses and exterior wall stud compression stresses from Tables 2.9A and 2.9B of the 2012 *Wood Frame Construction Manual*. Combined bending and axial load calculations in accordance with Section 3.9 of the 2012 AWC *National Design Specification for Wood Construction*. Bearing perpendicular to grain was checked for top and bottom plates per Section 3.10.2 of the NDS. Connection capacities from Table R602.3(1) were checked against the connection loads from Table 2.1 of the WFCM.

This new table provides additional flexibility beyond the old Table R602.3.1 and Exception #2 under Section R602.3.1 which replaced it. The new table covers framing spans of both 12 feet and 24 feet. In addition to 2-story foyers, small great rooms and gable end conditions, the new table would also apply to conditions such as an attached garage where studs over 10 feet may be required due to a sloped site or where additional headroom for a van may be desired. The table also works for a somewhat higher ground snow load (30 psf versus 25 psf) and in all areas outside the region where wind design is required per Figure R301.2(4)B. The table can also be used for walls with large openings, provided the number of additional king studs required by Section R602.7.5 are furnished on each side of the openings.

Cost Impact: Will not increase the cost of construction

The code change will actually save builders the cost of hiring an engineer to design the portion of the building falling outside the limits of Table R602.3(5) or Exception #2 of Section R602.3.1. The minimum cost to retain an engineer to design the limited area of tall studs is estimated to be \$400 to \$800. The code change will also allow 2x4 studs to be used in cases where 2x6 studs would have been needed previously, for a modest savings in material costs (about \$3-4 per stud).

Report of Committee Action Hearings

Committee Action:

Approved as Modified

Modify as follows:

**TABLE R602.3(6)
ALTERNATE WOOD BEARING WALL STUD SIZE, HEIGHT AND SPACING**

Stud Height	Supporting	Stud Spacing ^a	Ultimate Design Wind Speed					
			115 mph		130 mph ^b		140 mph ^b	
			<u>Maximum Roof/Floor Span</u>		<u>Maximum Roof/Floor Span</u>		<u>Maximum Roof/Floor Span</u>	
			12 ft.	24 ft.	12 ft.	24 ft.	12 ft.	24 ft.
11 ft.	Roof Only	12 in.	2x4	2x4	2x4	2x4	2x4	2x4
		16 in.	2x4	2x4	2x4	2x6	2x4	2x6
		24 in.	2x6	2x6	2x6	2x6	2x6	2x6

Stud Height	Supporting	Stud Spacing ^a	Ultimate Design Wind Speed					
			115 mph		130 mph ^b		140 mph ^b	
			Maximum Roof/Floor Span		Maximum Roof/Floor Span		Maximum Roof/Floor Span	
			12 ft.	24 ft.	12 ft.	24 ft.	12 ft.	24 ft.
	Roof and One Floor	12 in.	2x4	2x6	2x4	2x6	2x4	2x6
		16 in.	2x6	2x6	2x6	2x6	2x6	2x6
		24 in.	2x6	2x6	2x6	2x6	2x6	2x6
12 ft.	Roof Only	12 in.	2x4	2x4	2x4	2x6	2x4	2x6
		16 in.	2x4	2x6	2x6	2x6	2x6	2x6
		24 in.	2x6	2x6	2x6	2x6	2x6	2x6
	Roof and One Floor	12 in.	2x4	2x6	2x6	2x6	2x6	2x6
		16 in.	2x6	2x6	2x6	2x6	2x6	2x6
		24 in.	2x6	2x6	2x6	2x6	2x6	DR

For SI: 1 inch = 25.4mm, 1 foot = 304.8 mm, 1 mph = 0.447 m/s

DR = Design Required

- a. Wall studs not exceeding 16 in. on center shall be sheathed with minimum 1/2" (12/7 mm) gypsum board on the interior and 3/8" (9 mm) wood structural panel sheathing on the exterior. Wood structural panel sheathing shall be attached with 8d (2.5" x 0.131") nails spaced a maximum of 6" on center along panel edges and 12" on center at intermediate supports, and all panel joints shall occur over studs or blocking.
- b. Where the ultimate design wind speed exceeds 115 mph, studs shall be attached to top and bottom plates with connectors having a minimum 300 pound (136 kg) lateral capacity
- c. The maximum span is applicable to both simple- and multiple-span roof and floor conditions. The roof assembly shall not contain a habitable attic.

Committee Reason: The committee approved the proposal based on the proponents published reason statement. This provides improvement to the code by moving confusing requirements from the exception into a table. Also, it allows more flexibility as regards two stories. The modifications adds the term maximum to the headings for clarity and provides a footnote that adds clarification for the load condition used for the table,

Assembly Action

None

Final Action Results

RB218-16

AM

[←BACK](#)

Code Change No: **RB219-16**

Original Proposal

Section: R602.10.3, R602.3

Proponent: Paul Coats, PE CBO, American Wood Council, representing American Wood Council (pcoats@awc.org)

Revise as follows:

**TABLE R602.3(1)
FASTENING SCHEDULE**

ITEM	DESCRIPTION OF BUILDING ELEMENTS	NUMBER AND TYPE OF FASTENER ^{a, b, c}	SPACING AND LOCATION
Roof			
1	Blocking between ceiling joists or rafters to top plate	4-8d box (2 ¹ / ₂ " × 0.113") or 3-8d common (2 ¹ / ₂ " × 0.131"); or 3-10d box (3" × 0.128"); or 3-3" × 0.131" nails	Toe nail
2	Ceiling joists to top plate	4-8d box (2 ¹ / ₂ " × 0.113"); or 3-8d common (2 ¹ / ₂ " × 0.131"); or 3-10d box (3" × 0.128"); or 3-3" × 0.131" nails	Per joist, toe nail
3	Ceiling joist not attached to parallel rafter, laps over partitions [see Sections R802.3.1, R802.3.2 and Table R802.5.1(9)]	4-10d box (3" × 0.128"); or 3-16d common (3 ¹ / ₂ " × 0.162"); or 4-3" × 0.131" nails	Face nail
4	Ceiling joist attached to parallel rafter (heel joint) [see Sections R802.3.1 and R802.3.2 and Table R802.5.1(9)]	Table R802.5.1(9)	Face nail
5	Collar tie to rafter, face nail or 1 ¹ / ₄ " × 20 ga. ridge strap to rafter	4-10d box (3" × 0.128"); or 3-10d common (3" × 0.148"); or	Face nail each rafter

		4-3" × 0.131" nails	
6	Rafter or roof truss to plate	3-16d box nails (3 ¹ / ₂ " × 0.135"); or 3-10d common nails (3" × 0.148"); or 4-10d box (3" × 0.128"); or 4-3" × 0.131" nails	2 toe nails on one side and 1 toe nail on opposite side of each rafter or truss ¹
7	Roof rafters to ridge, valley or hip rafters or roof rafter to minimum 2" ridge beam	4-16d (3 ¹ / ₂ " × 0.135"); or 3-10d common (3 ¹ / ₂ " × 0.148"); or 4-10d box (3" × 0.128"); or 4-3" × 0.131" nails	Toe nail
		3-16d box 3 ¹ / ₂ " × 0.135"); or 2-16d common (3 ¹ / ₂ " × 0.162"); or 3-10d box (3" × 0.128"); or 3-3" × 0.131" nails	End nail
Wall			
8	Stud to stud (not at braced wall panels)	16d common (3 ¹ / ₂ " × 0.162")	24" o.c. face nail
		10d box (3" × 0.128"); or 3" × 0.131" nails	16" o.c. face nail
9	Stud to stud and abutting studs at intersecting wall corners (at braced wall panels)	16d box (3 ¹ / ₂ " × 0.135"); or 3" × 0.131" nails	12" o.c. face nail
		16d common (3 ¹ / ₂ " × 0.162")	16" o.c. face nail
10	Built-up header (2" to 2" header with ¹ / ₂ " spacer)	16d common (3 ¹ / ₂ " × 0.162")	16" o.c. each edge face nail
		16d box (3 ¹ / ₂ " × 0.135")	12" o.c. each edge face nail
11	Continuous header to stud	5-8d box (2 ¹ / ₂ " × 0.113"); or 4-8d common (2 ¹ / ₂ " × 0.131"); or 4-10d box (3" × 0.128")	Toe nail

12	Top plate to top plate	16d common ($3\frac{1}{2}" \times 0.162"$)	16" o.c. face nail
		10d box ($3" \times 0.128"$); or $3" \times 0.131"$ nails	12" o.c. face nail
13	Double top plate splice for SDCs A-D₂ with seismic braced wall line spacing < 25'	8-16d common ($3\frac{1}{2}" \times 0.162"$); or 12-16d box ($3\frac{1}{2}" \times 0.135"$); or 12-10d box ($3" \times 0.128"$); or 12- $3" \times 0.131"$ nails	Face nail on each side of end joint (minimum 24" lap splice length each side of end joint)
	Double top plate splice SDCs D₀, D₁, or D₂; and braced wall line spacing ≥ 25'	12-16d ($3\frac{1}{2}" \times 0.135"$)	
14	Bottom plate to joist, rim joist, band joist or blocking (not at braced wall panels)	16d common ($3\frac{1}{2}" \times 0.162"$)	16" o.c. face nail
		16d box ($3\frac{1}{2}" \times 0.135"$); or $3" \times 0.131"$ nails	12" o.c. face nail
15	Bottom plate to joist, rim joist, band joist or blocking (at braced wall panel)	3-16d box ($3\frac{1}{2}" \times 0.135"$); or 2-16d common ($3\frac{1}{2}" \times 0.162"$); or 4- $3" \times 0.131"$ nails	3 each 16" o.c. face nail 2 each 16" o.c. face nail 4 each 16" o.c. face nail
16	Top or bottom plate to stud	4-8d box ($2\frac{1}{2}" \times 0.113"$); or 3-16d box ($3\frac{1}{2}" \times 0.135"$); or 4-8d common ($2\frac{1}{2}" \times 0.131"$); or 4-10d box ($3" \times 0.128"$); or 4- $3" \times 0.131"$ nails	Toe nail
		3-16d box ($3\frac{1}{2}" \times 0.135"$); or 2-16d common ($3\frac{1}{2}" \times 0.162"$); or 3-10d box ($3" \times 0.128"$); or 3- $3" \times 0.131"$ nails	End nail
17	Top plates, laps at corners and intersections	3-10d box ($3" \times 0.128"$); or 2-16d common ($3\frac{1}{2}" \times 0.162"$); or 3- $3" \times 0.131"$ nails	Face nail
18	1" brace to each stud and plate	3-8d box ($2\frac{1}{2}" \times 0.113"$); or 2-8d common ($2\frac{1}{2}" \times 0.131"$); or 2-10d box ($3" \times 0.128"$); or 2-	Face nail

		staples 1 ³ / ₄ "	
19	1" × 6" sheathing to each bearing	3-8d box (2 ¹ / ₂ " × 0.113"); or2-8d common (2 ¹ / ₂ " × 0.131"); or2-10d box (3" × 0.128"); or2 staples, 1" crown, 16 ga., 1 ³ / ₄ " long	Face nail
20	1" × 8" and wider sheathing to each bearing	3-8d box (2 ¹ / ₂ " × 0.113"); or3-8d common (2 ¹ / ₂ " × 0.131"); or3-10d box (3" × 0.128"); or3 staples, 1" crown, 16 ga., 1 ³ / ₄ "long	Face nail
		Wider than 1" × 8"4-8d box (2 ¹ / ₂ " × 0.113"); or3-8d common (2 ¹ / ₂ " × 0.131"); or3-10d box (3" × 0.128"); or4 staples, 1" crown, 16 ga., 1 ³ / ₄ " long	
Floor			
21	Joist to sill, top plate or girder	4-8d box (2 ¹ / ₂ " × 0.113"); or3-8d common (2 ¹ / ₂ " × 0.131"); or3-10d box (3" × 0.128"); or3-3" × 0.131" nails	Toe nail
22	Rim joist, band joist or blocking to sill or top plate (roof applications also)	8d box (2 ¹ / ₂ " × 0.113")	4" o.c. toe nail
		8d common (2 ¹ / ₂ " × 0.131"); or10d box (3" × 0.128"); or3" × 0.131" nails	6" o.c. toe nail
23	1" × 6" subfloor or less to each joist	3-8d box (2 ¹ / ₂ " × 0.113"); or2-8d common (2 ¹ / ₂ " × 0.131"); or3-10d box (3" × 0.128"); or2 staples, 1" crown, 16 ga., 1 ³ / ₄ " long	Face nail
Floor			

24	2" subfloor to joist or girder	3-16d box (3 ¹ / ₂ " × 0.135"); or 2-16d common (3 ¹ / ₂ " × 0.162")	Blind and face nail	
25	2" planks (plank & beam—floor & roof)	3-16d box (3 ¹ / ₂ " × 0.135"); or 2-16d common (3 ¹ / ₂ " × 0.162")	At each bearing, face nail	
26	B and or rim joist to joist	3-16d common (3 ¹ / ₂ " × 0.162"); 4-10 box (3" × 0.128"), or 4-3" × 0.131" nails; or 4-3" × 14 ga. staples, ⁷ / ₁₆ " crown	End nail	
27	Built-up girders and beams, 2-inch lumber layers	20d common (4" × 0.192"); or	Nail each layer as follows: 32" o.c. at top and bottom and staggered.	
		10d box (3" × 0.128"); or 3" × 0.131" nails	24" o.c. face nail at top and bottom staggered on opposite sides	
		And: 2-20d common (4" × 0.192"); or 3-10d box (3" × 0.128"); or 3-3" × 0.131" nails	Face nail at ends and at each splice	
28	Ledger strip supporting joists or rafters	4-16d box (3 ¹ / ₂ " × 0.135"); or 3-16d common (3 ¹ / ₂ " × 0.162"); or 4-10d box (3" × 0.128"); or 4-3" × 0.131" nails	At each joist or rafter, face nail	
29	Bridging <u>or blocking</u> to joist	2-10d box (3" × 0.128"), <u>or</u> 2-8d common (2-1/2" × 0.131"); <u>or</u> 2-3" × 0.131" nails	Each end, toe nail	
ITEM	DESCRIPTION OF BUILDING ELEMENTS	NUMBER AND TYPE OF FASTENER ^{a, b, c}	SPACING OF FASTENERS	
			Edges (inches) ^h	Intermediate supports ^e (inches) ^c
Wood structural panels, subfloor, roof and interior wall sheathing to framing and particleboard wall sheathing to framing [see Table R602.3(3) for wood structural panel exterior wall sheathing to wall framing]				




30	$\frac{3}{8}$ " - $\frac{1}{2}$ "	6d common (2" × 0.113") nail (subfloor, wall) ¹ 8d common ($2\frac{1}{2}$ " × 0.131") nail (roof)	6	12 ^f
31	$\frac{19}{32}$ " - 1"	8d common nail ($2\frac{1}{2}$ " × 0.131")	6	12 ^f
32	$1\frac{1}{8}$ " - $1\frac{1}{4}$ "	10d common (3" × 0.148") nail; or 8d ($2\frac{1}{2}$ " × 0.131") deformed nail	6	12
Other wall sheathing⁹				
33	$\frac{1}{2}$ " structural cellulosic fiberboardsheathing	$1\frac{1}{2}$ " galvanized roofing nail, $\frac{7}{16}$ " head diameter, or <u>4" crown staple 16 ga., $1\frac{1}{4}$" long 16 ga. staple with $\frac{7}{16}$" or 1" crown</u>	3	6
34	$\frac{25}{32}$ " structural cellulosic fiberboard sheathing	$1\frac{3}{4}$ " galvanized roofing nail, $\frac{7}{16}$ " head diameter, or <u>4" crown staple 16 ga., $1\frac{1}{4}$" long 1-1/2" long 16 ga. staple with $\frac{7}{16}$" or 1" crown</u>	3	6
35	$\frac{1}{2}$ " gypsum sheathing ^d	$1\frac{1}{2}$ " galvanized roofing nail; staple galvanized, $1\frac{1}{2}$ " long; $1\frac{1}{4}$ " screws, Type W or S	7	7
36	$\frac{5}{8}$ " gypsum sheathing ^d	$1\frac{3}{4}$ " galvanized roofing nail; staple galvanized, $1\frac{5}{8}$ " long; $1\frac{5}{8}$ " screws, Type W or S	7	7
Wood structural panels, combination subfloor underlayment to framing				
37	$\frac{3}{4}$ " and less	6d deformed (2" × 0.120") nail; or 8d common ($2\frac{1}{2}$ " × 0.131") nail	6	12
38	$\frac{7}{8}$ " - 1"	8d common ($2\frac{1}{2}$ " × 0.131") nail; or 8d deformed ($2\frac{1}{2}$ " × 0.120") nail	6	12

39	1 ¹ / ₈ " - 1 ¹ / ₄ "	10d common (3" × 0.148") nail; or 8d deformed (2 ¹ / ₂ " × 0.120") nail	6	12
----	---	---	---	----

For SI: 1 inch = 25.4 mm, 1 foot = 304.8 mm, 1 mile per hour = 0.447 m/s; 1 ksi = 6.895 MPa.

- a. Nails are smooth-common, box or deformed shanks except where otherwise stated. Nails used for framing and sheathing connections shall have minimum average bending yield strengths as shown: 80 ksi for shank diameter of 0.192 inch (20d common nail), 90 ksi for shank diameters larger than 0.142 inch but not larger than 0.177 inch, and 100 ksi for shank diameters of 0.142 inch or less.
- b. Staples are 16 gage wire and have a minimum ⁷/₁₆-inch on diameter crown width.
- c. Nails shall be spaced at not more than 6 inches on center at all supports where spans are 48 inches or greater.
- d. Four-foot by 8-foot or 4-foot by 9-foot panels shall be applied vertically.
- e. Spacing of fasteners not included in this table shall be based on Table R602.3(2).
- f. Where the ultimate design wind speed is 130 mph or less, nails for attaching wood structural panel roof sheathing to gable end wall framing shall be spaced 6 inches on center. Where the ultimate design wind speed is greater than 130 mph, nails for attaching panel roof sheathing to intermediate supports shall be spaced 6 inches on center for minimum 48-inch distance from ridges, eaves and gable end walls; and 4 inches on center to gable end wall framing.
- g. Gypsum sheathing shall conform to ASTM C 1396 and shall be installed in accordance with GA 253. Fiberboard sheathing shall conform to ASTM C 208.
- h. Spacing of fasteners on floor sheathing panel edges applies to panel edges supported by framing members and required blocking and at floor perimeters only. Spacing of fasteners on roof sheathing panel edges applies to panel edges supported by framing members and required blocking. Blocking of roof or floor sheathing panel edges perpendicular to the framing members need not be provided except as required by other provisions of this code. Floor perimeter shall be supported by framing members or solid blocking.
- i. Where a rafter is fastened to an adjacent parallel ceiling joist in accordance with this schedule, provide two toe nails on one side of the rafter and toe nails from the ceiling joist to top plate in accordance with this schedule. The toe nail on the opposite side of the rafter shall not be required.

TABLE R602.10.3 (4)
SEISMIC ADJUSTMENT FACTORS TO THE REQUIRED LENGTH OF WALL BRACING

ITEM NUMBER	ADJUSTMENT BASED ON:	STORY	CONDITION	ADJUSTMENT FACTOR ^{a, b} [Multiply length from Table R602.10.3(3) by this factor]	APPLICABLE METHODS
1	Story height (Section 301.3)	Any story	≤ 10 feet	1.0	All methods
			> 10 feet and ≤ 12 feet	1.2	
2	Braced wall line spacing, townhouses in SDC C	Any story	≤ 35 feet	1.0	
			> 35 feet and ≤ 50 feet	1.43	
3	Braced wall line spacing, in SDC D ₀ , D ₁ , D ₂ ^c	Any story	> 25 feet and ≤ 30 feet	1.2	
			> 30 feet and ≤ 35 feet	1.4	
4	Wall dead load	Any story	> 8 psf and < 15 psf	1.0	
			< 8 psf	0.85	
5	Roof/ceiling dead load for wall supporting	1-, 2- or 3-story building	≤ 15 psf	1.0	
		2- or 3-story building	> 15 psf and ≤ 25 psf	1.1	
		1-story building	> 15 psf and ≤ 25 psf	1.2	
6	Walls with stone or masonry veneer, townhouses in SDC C ^{d, e}		1.0	All methods	
			1.5		
			1.5		
7	Walls with stone or masonry veneer, detached one- and two-family dwellings in SDC D ₀ – D ₂ ^{d, f}	Any story	See Table R602.10.6.5	BV-WSP	
8	Interior gypsum board finish (or equivalent)	Any story	Omitted from inside face of braced wall panels	1.5	DWB, WSP, SFB, PBS, PCP, HPS, CS-WSP, CS-G, CS-SFB

For SI: 1 foot = 304.8 mm, 1 pound per square foot = 0.0479 kPa.

- Linear interpolation shall be permitted.
- The total length of bracing required for a given wall line is the product of all applicable adjustment factors.
- The length-to-width ratio for the floor/roof *diaphragm* shall not exceed 3:1. ~~The top plate lap splice nailing shall be in accordance with Table R602.3(1), Item 13.~~
- Applies to stone or masonry veneer exceeding the first story height.
- The adjustment factor for stone or masonry veneer shall be applied to all exterior *braced wall lines* and all *braced wall lines* on the interior of the building, backing or perpendicular to and laterally supported veneered walls.
- See Section R602.10.6.5 for requirements where stone or masonry veneer does not exceed the first-story height.

Reason: ITEM 7: The correct length of the 10d common nail is 3", not 3-1/2". 10d common is correctly shown as 3" long elsewhere in the table. This is considered to be an editorial change as a 10d common nail is 3" long per ASTM F1667 and correctly shown as 3" long elsewhere in the table.

ITEM 13: Multiple changes to the top plate splice nailing were approved in the previous code change cycle. One change, RB272-13, increased the nailing of the top plate splice to bring it in line with the 2015 IBC as well as to include nailing schedules that are of roughly equivalent lateral resistance. A second change, RB274-13, specified increased top plate splice nailing only for higher SDCs and where braced wall line spacing is greater than 25'. The combination of both proposals produced line 13 of the 2015 IRC in which the same double top plate splice nailing is shown for wall line spacing <25' and ≥25' (i.e. 12-16d (3-1/2" x 0.135" box nails). To simplify presentation of the top plate nailing schedule to the singular nailing pattern intended by RB272-13, it is proposed to delete language associated with triggering different nailing based on SDC or wall line spacing. The special reference from footnote c of Table R602.10.3(4) that addresses applicable top plate nailing is also no longer necessary with the proposed revision to a single nail schedule and is proposed to be deleted. Related: prior cycle RB272-13, RB274-13, Rb278-13.

ITEM 23: The equivalent nailing to the 8d common case is (2) 10d box versus (3) 10d box. 2 nails is consistent with item 24 in IBC Table 2304.10.1.

ITEM 29: The "bridging to joist" case was added during the previous code change cycle but included only the 10d (3" x 0.128") nail option. The 10d is clarified as a box nail size in this change. Other equivalent nail options are added and "or blocking" is added to the description to pick up the commonly used term for the application being described.

ITEMS 33 and 34: 7/16" crown was inadvertently excluded from change proposal RB278-13 which reorganized the fastening table to create a more consistent format between the IBC and IRC prescriptive fastening tables. This change restores the 7/16" crown. It also increases the staple length for 25/32" sheathing thickness which was previously proposed and approved (S75-06/07 Part II) but not picked up in publication.

REVISION TO FOOTNOTE c IN TABLE R602.10.3(4): See the explanation in Item 13 above, and the last sentence.

Cost Impact: Will not increase the cost of construction

Because these are mostly editorial corrections and correlations, it is not anticipated that the cost of construction will increase. For rows where the nailing changes slightly, current alternatives are also retained.

Report of Committee Action Hearings

Committee Action:

Approved as Submitted

Errata: In Table R602,10.3(4), at Item 6 under story, the icons are not deleted.

Committee Reason: The committee approved this proposal based on the proponents published reason statement.

Assembly Action:

None

Final Action Results

RB219-16

AS

Code Change No: RB220-16

Original Proposal

Section: R602.3

Proponent: Paul Coats, PE CBO, American Wood Council, representing American Wood Council (pcoats@awc.org)

Revise as follows:

**TABLE R602.3 (1)
FASTENING SCHEDULE**

ITEM	DESCRIPTION OF BUILDING ELEMENTS	NUMBER AND TYPE OF FASTENER ^{a, b, c}	SPACING AND LOCATION
Roof			
1	Blocking between ceiling joists or rafters to top plate	4-8d box (2 ¹ / ₂ " × 0.113") or 3-8d common (2 ¹ / ₂ " × 0.131"); or 3-10d box (3" × 0.128"); or 3-3" × 0.131" nails	Toe nail
2	Ceiling joists to top plate	4-8d box (2 ¹ / ₂ " × 0.113"); or 3-8d common (2 ¹ / ₂ " × 0.131"); or 3-10d box (3" × 0.128"); or 3-3" × 0.131" nails	Per joist, toe nail
3	Ceiling joist not attached to parallel rafter, laps over partitions [see Sections R802.3.1, R802.3.2 and Table R802.5.1(9)]	4-10d box (3" × 0.128"); or 3-16d common (3 ¹ / ₂ " × 0.162"); or 4-3" × 0.131" nails	Face nail
4	Ceiling joist attached to parallel rafter (heel joint) [see Sections R802.3.1 and R802.3.2 and Table R802.5.1(9)]	Table R802.5.1(9)	Face nail
5	Collar tie to rafter, face nail or 1 ¹ / ₄ " × 20 ga. ridge strap to rafter	4-10d box (3" × 0.128"); or 3-10d common (3" × 0.148"); or 4-3" × 0.131" nails	Face nail each rafter
6	Rafter or roof truss to plate	3-16d box nails (3 ¹ / ₂ " × 0.135"); or 3-10d common nails (3" × 0.148"); or 4-10d box (3" × 0.128"); or 4-3" × 0.131" nails	2 toe nails on one side and 1 toe nail on opposite side of each rafter or truss ⁱ
7	Roof rafters to ridge, valley or hip rafters or roof rafter to minimum 2" ridge beam	4-16d (3 ¹ / ₂ " × 0.135"); or 3-10d common (3 ¹ / ₂ " × 0.148"); or 4-10d box (3" × 0.128"); or 4-3" × 0.131" nails	Toe nail
		3-16d box 3 ¹ / ₂ " × 0.135"); or 2-16d common (3 ¹ / ₂ " × 0.162"); or 3-10d box (3" × 0.128"); or 3-3" × 0.131" nails	End nail
Wall			
8	Stud to stud (not at braced wall panels)	16d common (3 ¹ / ₂ " × 0.162")	24" o.c. face nail
		10d box (3" × 0.128"); or 3" × 0.131" nails	16" o.c. face nail
9	Stud to stud and abutting studs at intersecting wall corners	16d box (3 ¹ / ₂ " × 0.135"); or 3" × 0.131" nails	12" o.c. face nail

	(at braced wall panels)	16d common (3 ¹ / ₂ " × 0.162")	16" o.c. face nail
10	Built-up header (2" to 2" header with 1 ¹ / ₂ " spacer)	16d common (3 ¹ / ₂ " × 0.162")	16" o.c. each edge face nail
		16d box (3 ¹ / ₂ " × 0.135")	12" o.c. each edge face nail
11	Continuous header to stud	5-8d box (2 ¹ / ₂ " × 0.113"); or 4-8d common (2 ¹ / ₂ " × 0.131"); or 4-10d box (3" × 0.128")	Toe nail
12	Top plate to top plate	16d common (3 ¹ / ₂ " × 0.162")	16" o.c. face nail
		10d box (3" × 0.128"); or 3" × 0.131" nails	12" o.c. face nail
13	Double top plate splice for SDCs A-D2 with seismic braced wall line spacing	8-16d common (3 ¹ / ₂ " × 0.162"); or 12-16d box (3 ¹ / ₂ " × 0.135"); or 12-10d box (3" × 0.128"); or 12-3" × 0.131" nails	Face nail on each side of end joint (minimum 24" lap splice length each side of end joint)
	Double top plate splice SDCs D ₀ , D ₁ , or D ₂ ; and braced wall line spacing ≥ 25'	12-16d (3 ¹ / ₂ " × 0.135")	
14	Bottom plate to joist, rim joist, band joist or blocking (not at braced wall panels)	16d common (3 ¹ / ₂ " × 0.162")	16" o.c. face nail
		16d box (3 ¹ / ₂ " × 0.135"); or 3" × 0.131" nails	12" o.c. face nail
15	Bottom plate to joist, rim joist, band joist or blocking (at braced wall panel)	3-16d box (3 ¹ / ₂ " × 0.135"); or 2-16d common (3 ¹ / ₂ " × 0.162"); or 4-3" × 0.131" nails	3 each 16" o.c. face nail 2 each 16" o.c. face nail 4 each 16" o.c. face nail
16	Top or bottom plate to stud	4-8d box (2 ¹ / ₂ " × 0.113"); or 3-16d box (3 ¹ / ₂ " × 0.135"); or 4-8d common (2 ¹ / ₂ " × 0.131"); or 4-10d box (3" × 0.128"); or 4-3" × 0.131" nails	Toe nail
		3-16d box (3 ¹ / ₂ " × 0.135"); or 2-16d common (3 ¹ / ₂ " × 0.162"); or 3-10d box (3" × 0.128"); or 3-3" × 0.131" nails	End nail
17	Top plates, laps at corners and intersections	3-10d box (3" × 0.128"); or 2-16d common (3 ¹ / ₂ " × 0.162"); or 3-3" × 0.131" nails	Face nail
18	1" brace to each stud and plate	3-8d box (2 ¹ / ₂ " × 0.113"); or 2-8d common (2 ¹ / ₂ " × 0.131"); or 2-10d box (3" × 0.128"); or 2 staples 1 ³ / ₄ "	Face nail
19	1" × 6" sheathing to each bearing	3-8d box (2 ¹ / ₂ " × 0.113"); or 2-8d common (2 ¹ / ₂ " × 0.131"); or 2-10d box (3" × 0.128"); or 2 staples, 1" crown, 16 ga., 1 ³ / ₄ " long	Face nail
20	1" × 8" and wider sheathing to each bearing	3-8d box (2 ¹ / ₂ " × 0.113"); or 3-8d common (2 ¹ / ₂ " × 0.131"); or 3-10d box (3" × 0.128"); or 3 staples, 1" crown, 16 ga., 1 ³ / ₄ " long	Face nail
		Wider than 1" × 8" 4-8d box (2 ¹ / ₂ " × 0.113"); or 3-8d common (2 ¹ / ₂ " × 0.131"); or 3-10d box (3" × 0.128"); or 4 staples, 1" crown, 16 ga., 1 ³ / ₄ " long	
Floor			
21	Joist to sill, top plate or girder	4-8d box (2 ¹ / ₂ " × 0.113"); or 3-8d common (2 ¹ / ₂ " × 0.131"); or 3-10d box (3" × 0.128"); or 3-3" × 0.131" nails	Toe nail
22	Rim joist, band joist or blocking to sill or top plate (roof applications also)	8d box (2 ¹ / ₂ " × 0.113")	4" o.c. toe nail
		8d common (2 ¹ / ₂ " × 0.131"); or 10d box (3" × 0.128"); or 3" × 0.131" nails	6" o.c. toe nail
23	1" × 6" subfloor or less to each joist	3-8d box (2 ¹ / ₂ " × 0.113"); or 2-8d common	Face nail

		(2 ¹ / ₂ " × 0.131"); or 3-10d box (3" × 0.128"); or 2 staples, 1" crown, 16 ga., 1 ³ / ₄ " long		
Floor				
24	2"subfloor to joist or girder	3-16d box (3 ¹ / ₂ " × 0.135"); or 2-16d common (3 ¹ / ₂ " × 0.162")	Blind and face nail	
25	2"planks (plank & beam—floor & roof)	3-16d box (3 ¹ / ₂ " × 0.135"); or 2-16d common (3 ¹ / ₂ " × 0.162")	At each bearing, face nail	
26	Band or rim joist to joist	3-16d common (3 ¹ / ₂ " × 0.162") 4-10 box (3" × 0.128"), or 4-3" × 0.131"nails; or 4-3" × 14 ga. staples, ⁷ / ₁₆ " crown	End nail	
27	Built-up girders and beams, 2-inch lumber layers	20d common (4" × 0.192"); or	Nail each layer as follows: 32"o.c. at top and bottom and staggered.	
		10d box (3" × 0.128"); or 3" × 0.131"nails	24"o.c. face nail at top and bottom staggered on opposite sides	
		And: 2-20d common (4" × 0.192"); or 3-10d box (3" × 0.128"); or 3-3" × 0.131"nails	Face nail at ends and at each splice	
28	Ledger strip supporting joists or rafters	4-16d box (3 ¹ / ₂ " × 0.135"); or 3-16d common (3 ¹ / ₂ " × 0.162"); or 4-10d box (3" × 0.128"); or 4-3" × 0.131"nails	At each joist or rafter, face nail	
29	Bridging to joist	2-10d (3" × 0.128")	Each end, toe nail	
ITEM	DESCRIPTION OF BUILDING ELEMENTS	NUMBER AND TYPE OF FASTENER ^{a, b, c}	SPACING OF FASTENERS	
			Edges (inches) ^h	Intermediate supports ^{c, e} (inches)
Wood structural panels, subfloor, roof and interior wall sheathing to framing and particleboard wall sheathing to framing [see Table R602.3(3) for wood structural panel exterior wall sheathing to wall framing]				
30	³ / ₈ " – ¹ / ₂ "	6d common (2" × 0.113") nail (subfloor, wall) ^g 8d common (2 ¹ / ₂ " × 0.131") nail (roof); or RSR-01 (2-3/8" × 0.113") nail (roof) ⁱ	6	12 ^f
31	¹⁹ / ₃₂ " – 1"	8d common nail (2 ¹ / ₂ " × 0.131"); or RSR-01 (2 3/8" × 0.113") nail (roof) ⁱ	6	12 ^f
32	1 ¹ / ₈ " – 1 ¹ / ₄ "	10d common (3" × 0.148") nail; or 8d (2 ¹ / ₂ " × 0.131") deformed nail	6	12
Other wall sheathing^g				
33	¹ / ₂ " structural cellulosic fiberboard sheathing	1 ¹ / ₂ " galvanized roofing nail, ⁷ / ₁₆ " head diameter, or 1" crown staple 16 ga., 1 ¹ / ₄ " long	3	6
34	²⁵ / ₃₂ " structural cellulosic fiberboard sheathing	1 ³ / ₄ " galvanized roofing nail, ⁷ / ₁₆ " head diameter, or 1" crown staple 16 ga., 1 ¹ / ₄ " long	3	6
35	¹ / ₂ " gypsum sheathing ^d	1 ¹ / ₂ " galvanized roofing nail; staple galvanized, 1 ¹ / ₂ " long; 1 ¹ / ₄ " screws, Type W or S	7	7
36	⁵ / ₈ " gypsum sheathing ^d	1 ³ / ₄ " galvanized roofing nail; staple galvanized, 1 ⁵ / ₈ " long; 1 ⁵ / ₈ " screws, Type W or S	7	7
Wood structural panels, combination subfloor underlayment to framing				
37	³ / ₄ " and less	6d deformed (2" × 0.120") nail; or 8d common (2 ¹ / ₂ " × 0.131") nail	6	12

38	$7/8$ " – 1"	8d common ($2^{1/2}$ " × 0.131") nail; or 8d deformed ($2^{1/2}$ " × 0.120") nail	6	12
39	$1^{1/8}$ " – $1^{1/4}$ "	10d common (3" × 0.148") nail; or 8d deformed ($2^{1/2}$ " × 0.120") nail	6	12

For SI: 1 inch = 25.4 mm, 1 foot = 304.8 mm, 1 mile per hour = 0.447 m/s; 1 ksi = 6.895 MPa.

- a. Nails are smooth-common, box or deformed shanks except where otherwise stated. Nails used for framing and sheathing connections shall have minimum average bending yield strengths as shown: 80 ksi for shank diameter of 0.192 inch (20d common nail), 90 ksi for shank diameters larger than 0.142 inch but not larger than 0.177 inch, and 100 ksi for shank diameters of 0.142 inch or less.
- b. Staples are 16 gage wire and have a minimum $7/16$ -inch on diameter crown width.
- c. Nails shall be spaced at not more than 6 inches on center at all supports where spans are 48 inches or greater.
- d. Four-foot by 8-foot or 4-foot by 9-foot panels shall be applied vertically.
- e. Spacing of fasteners not included in this table shall be based on Table R602.3(2).
- f. Where the ultimate design wind speed is 130 mph or less, nails for attaching wood structural panel roof sheathing to gable end wall framing shall be spaced 6 inches on center. Where the ultimate design wind speed is greater than 130 mph, nails for attaching panel roof sheathing to intermediate supports shall be spaced 6 inches on center for minimum 48-inch distance from ridges, eaves and gable end walls; and 4 inches on center to gable end wall framing.
- g. Gypsum sheathing shall conform to ASTM C 1396 and shall be installed in accordance with GA 253. Fiberboard sheathing shall conform to ASTM C 208.
- h. Spacing of fasteners on floor sheathing panel edges applies to panel edges supported by framing members and required blocking and at floor perimeters only. Spacing of fasteners on roof sheathing panel edges applies to panel edges supported by framing members and required blocking. Blocking of roof or floor sheathing panel edges perpendicular to the framing members need not be provided except as required by other provisions of this code. Floor perimeter shall be supported by framing members or solid blocking.
- i. Where a rafter is fastened to an adjacent parallel ceiling joist in accordance with this schedule, provide two toe nails on one side of the rafter and toe nails from the ceiling joist to top plate in accordance with this schedule. The toe nail on the opposite side of the rafter shall not be required.
- j. RSRS-01 is a Roof Sheathing Ring Shank nail meeting the specifications in ASTM F1667.

Reason: This change adds a new standardized roof sheathing ring shank (RSRS) nail for roof sheathing applications. The RSRS nail has been standardized in ASTM F1667 and added in this proposal as equivalent to the 8d common nail to resist uplift of roof sheathing. This standard ring shank nail provides improved withdrawal resistance relative to the 8d common smooth shank nail. A head size of 0.281" diameter is specified for the RSRS-01 in ASTM F1667 which is equivalent to the head diameter of the 8d common nail. The slightly larger net area under the head (i.e. area of head minus area of shank) is considered to provide slightly improved head pull through performance.

Cost Impact: Will not increase the cost of construction

An alternative nail is being added only, so there is no increase in cost since the current nailing alternatives may still be used.

Report of Committee Action Hearings

Committee Action:

Approved as Submitted

Committee Reason: This proposal adds a new ring shank nail for roof sheathing that provides improved withdrawal. The nail has been standardized in ASTM F1667.

Assembly Action:

None

Final Action Results

RB220-16

AS

[←BACK](#)

Code Change No: RB221-16

Original Proposal

Section: R602.3, R803.2.3

Proponent: James Smith (jsmith@awc.org)

Revise as follow:

**TABLE R602.3 (1)
FASTENING SCHEDULE**

ITEM	DESCRIPTION OF BUILDING ELEMENTS	NUMBER AND TYPE OF FASTENER ^{a, b, c}	SPACING AND LOCATION
Roof			
1	Blocking between ceiling joists or rafters to top plate	4-8d box (2 ¹ / ₂ " × 0.113") or 3-8d common (2 ¹ / ₂ " × 0.131"); or 3-10d box (3" × 0.128"); or 3-3" × 0.131" nails	Toe nail
2	Ceiling joists to top plate	4-8d box (2 ¹ / ₂ " × 0.113"); or 3-8d common (2 ¹ / ₂ " × 0.131"); or 3-10d box (3" × 0.128"); or 3-3" × 0.131" nails	Per joist, toe nail
3	Ceiling joist not attached to parallel rafter, laps over partitions [see Sections R802.3.1, R802.3.2 and Table R802.5.1(9)]	4-10d box (3" × 0.128"); or 3-16d common (3 ¹ / ₂ " × 0.162"); or 4-3" × 0.131" nails	Face nail
4	Ceiling joist attached to parallel rafter (heel joint) [see Sections R802.3.1 and R802.3.2 and Table R802.5.1(9)]	Table R802.5.1(9)	Face nail
5	Collar tie to rafter, face nail or 1 ¹ / ₄ " × 20 ga. ridge strap to rafter	4-10d box (3" × 0.128"); or 3-10d common (3" × 0.148"); or 4-3" × 0.131" nails	Face nail each rafter
6	Rafter or roof truss to plate	3-16d box nails (3 ¹ / ₂ " × 0.135"); or 3-10d common nails (3" × 0.148"); or 4-10d box (3" × 0.128"); or 4-3" × 0.131" nails	2 toe nails on one side and 1 toe nail on opposite side of each rafter or truss ⁱ
7	Roof rafters to ridge, valley or hip rafters or roof rafter to minimum 2" ridge beam	4-16d (3 ¹ / ₂ " × 0.135"); or 3-10d common (3 ¹ / ₂ " × 0.148"); or 4-10d box (3" × 0.128"); or 4-3" × 0.131" nails 3-16d box 3 ¹ / ₂ " × 0.135"); or 2-16d common (3 ¹ / ₂ " × 0.162"); or 3-10d box (3" × 0.128"); or 3-3" × 0.131" nails	Toe nail End nail
Wall			
8	Stud to stud (not at braced wall panels)	16d common (3 ¹ / ₂ " × 0.162") 10d box (3" × 0.128"); or 3" × 0.131" nails	24" o.c. face nail 16" o.c. face nail
9	Stud to stud and abutting studs at intersecting wall corners (at braced wall panels)	16d box (3 ¹ / ₂ " × 0.135"); or 3" × 0.131" nails 16d common (3 ¹ / ₂ " × 0.162")	12" o.c. face nail 16" o.c. face nail
10	Built-up header (2" to 2" header with 1 ¹ / ₂ " spacer)	16d common (3 ¹ / ₂ " × 0.162") 16d box (3 ¹ / ₂ " × 0.135")	16" o.c. each edge face nail 12" o.c. each edge face nail
11	Continuous header to stud	5-8d box (2 ¹ / ₂ " × 0.113"); or 4-8d common (2 ¹ / ₂ " × 0.131"); or 4-10d box (3" × 0.128")	Toe nail

12	Top plate to top plate	16d common (3 ¹ / ₂ " × 0.162")	16" o.c. face nail
		10d box (3" × 0.128"); or 3" × 0.131" nails	12" o.c. face nail
13	Double top plate splice for SDCs A-D2 with seismic braced wall line spacing	8-16d common (3 ¹ / ₂ " × 0.162"); or 12-16d box (3 ¹ / ₂ " × 0.135"); or 12-10d box (3" × 0.128"); or 12-3" × 0.131" nails	Face nail on each side of end joint (minimum 24" lap splice length each side of end joint)
	Double top plate splice SDCs D ₀ , D ₁ , or D ₂ ; and braced wall line spacing ≥ 25'	12-16d (3 ¹ / ₂ " × 0.135")	
ITEM	DESCRIPTION OF BUILDING ELEMENTS	NUMBER AND TYPE OF FASTENER ^{a, b, c}	SPACING AND LOCATION
14	Bottom plate to joist, rim joist, band joist or blocking (not at braced wall panels)	16d common (3 ¹ / ₂ " × 0.162")	16" o.c. face nail
		16d box (3 ¹ / ₂ " × 0.135"); or 3" × 0.131" nails	12" o.c. face nail
15	Bottom plate to joist, rim joist, band joist or blocking (at braced wall panel)	3-16d box (3 ¹ / ₂ " × 0.135"); or 2-16d common (3 ¹ / ₂ " × 0.162"); or 4-3" × 0.131" nails	3 each 16" o.c. face nail 2 each 16" o.c. face nail 4 each 16" o.c. face nail
16	Top or bottom plate to stud	4-8d box (2 ¹ / ₂ " × 0.113"); or 3-16d box (3 ¹ / ₂ " × 0.135"); or 4-8d common (2 ¹ / ₂ " × 0.131"); or 4-10d box (3" × 0.128"); or 4-3" × 0.131" nails	Toe nail
		3-16d box (3 ¹ / ₂ " × 0.135"); or 2-16d common (3 ¹ / ₂ " × 0.162"); or 3-10d box (3" × 0.128"); or 3-3" × 0.131" nails	End nail
17	Top plates, laps at corners and intersections	3-10d box (3" × 0.128"); or 2-16d common (3 ¹ / ₂ " × 0.162"); or 3-3" × 0.131" nails	Face nail
18	1" brace to each stud and plate	3-8d box (2 ¹ / ₂ " × 0.113"); or 2-8d common (2 ¹ / ₂ " × 0.131"); or 2-10d box (3" × 0.128"); or 2 staples 1 ³ / ₄ "	Face nail
19	1" × 6" sheathing to each bearing	3-8d box (2 ¹ / ₂ " × 0.113"); or 2-8d common (2 ¹ / ₂ " × 0.131"); or 2-10d box (3" × 0.128"); or 2 staples, 1" crown, 16 ga., 1 ³ / ₄ " long	Face nail
20	1" × 8" and wider sheathing to each bearing	3-8d box (2 ¹ / ₂ " × 0.113"); or 3-8d common (2 ¹ / ₂ " × 0.131"); or 3-10d box (3" × 0.128"); or 3 staples, 1" crown, 16 ga., 1 ³ / ₄ " long	Face nail
		Wider than 1" × 8" 4-8d box (2 ¹ / ₂ " × 0.113"); or 3-8d common (2 ¹ / ₂ " × 0.131"); or 3-10d box (3" × 0.128"); or 4 staples, 1" crown, 16 ga., 1 ³ / ₄ " long	
Floor			
21	Joist to sill, top plate or girder	4-8d box (2 ¹ / ₂ " × 0.113"); or 3-8d common (2 ¹ / ₂ " × 0.131"); or 3-10d box (3" × 0.128"); or 3-3" × 0.131" nails	Toe nail
22	Rim joist, band joist or blocking to sill or top plate (roof applications also)	8d box (2 ¹ / ₂ " × 0.113")	4" o.c. toe nail
		8d common (2 ¹ / ₂ " × 0.131"); or 10d box (3" × 0.128"); or 3" × 0.131" nails	6" o.c. toe nail
23	1" × 6" subfloor or less to each joist	3-8d box (2 ¹ / ₂ " × 0.113"); or 2-8d common (2 ¹ / ₂ " × 0.131"); or 3-10d box (3" × 0.128"); or 2 staples, 1" crown, 16 ga., 1 ³ / ₄ " long	Face nail

ITEM	DESCRIPTION OF BUILDING ELEMENTS	NUMBER AND TYPE OF FASTENER ^{a, b, c}	SPACING AND LOCATION
Floor			
24	2" subfloor to joist or girder	3-16d box (3 ¹ / ₂ " × 0.135"); or 2-16d common (3 ¹ / ₂ " × 0.162")	Blind and face nail
25	2" planks (plank & beam—floor & roof)	3-16d box (3 ¹ / ₂ " × 0.135"); or 2-16d common (3 ¹ / ₂ " × 0.162")	At each bearing, face nail
26	Band or rim joist to joist	3-16d common (3 ¹ / ₂ " × 0.162") 4-10 box (3" × 0.128"), or 4-3" × 0.131" nails; or 4-3" ×	End nail

		14 ga. staples, ⁷ / ₁₆ " crown		
27	Built-up girders and beams, 2-inch lumber layers	20d common (4"× 0.192"); or	Nail each layer as follows: 32"o.c. at top and bottom and staggered.	
		10d box (3"× 0.128"); or 3"× 0.131"nails	24"o.c. face nail at top and bottom staggered on opposite sides	
		And: 2-20d common (4"× 0.192"); or 3-10d box (3"× 0.128"); or 3-3"× 0.131"nails	Face nail at ends and at each splice	
28	Ledger strip supporting joists or rafters	4-16d box (3 ¹ / ₂ "× 0.135"); or 3-16d common (3 ¹ / ₂ "× 0.162"); or 4-10d box (3"× 0.128"); or 4-3"× 0.131"nails	At each joist or rafter, face nail	
29	Bridging to joist	2-10d (3"× 0.128")	Each end, toe nail	
ITEM	DESCRIPTION OF BUILDING ELEMENTS	NUMBER AND TYPE OF FASTENER ^{a, b, c}	SPACING OF FASTENERS	
			Panel Edges (inches) ^h	Intermediate supports ^{c, e} (inches)
Wood structural panels, subfloor, roof and interior wall sheathing to framing and particleboard wall sheathing to framing [see Table R602.3(3) for wood structural panel exterior wall sheathing to wall framing]				
30	³ / ₈ " – ¹ / ₂ "	6d common (2"× 0.113") nail (subfloor, wall) ⁱ 8d common (2 ¹ / ₂ "× 0.131") nail (roof)	6	12 ^f
31	¹⁹ / ₃₂ " – 1"	8d common nail (2 ¹ / ₂ "× 0.131")	6	12 ^f
32	1 ¹ / ₈ " – 1 ¹ / ₄ "	10d common (3"× 0.148") nail; or 8d (2 ¹ / ₂ "× 0.131") deformed nail	6	6
33	¹ / ₂ " structural cellulosic fiberboard sheathing	1 ¹ / ₂ " galvanized roofing nail, ⁷ / ₁₆ " head diameter, or 1" crown staple 16 ga., 1 ¹ / ₄ " long	3	6
34	²⁵ / ₃₂ " structural cellulosic fiberboard sheathing	1 ³ / ₄ " galvanized roofing nail, ⁷ / ₁₆ " head diameter, or 1" crown staple 16 ga., 1 ¹ / ₄ " long	3	7
35	¹ / ₂ " gypsum sheathing ^d	1 ¹ / ₂ " galvanized roofing nail; staple galvanized, 1 ¹ / ₂ " long; 1 ¹ / ₄ " screws, Type W or S	7	7
36	⁵ / ₈ " gypsum sheathing ^d	1 ³ / ₄ " galvanized roofing nail; staple galvanized, 1 ⁵ / ₈ " long; 1 ⁵ / ₈ " screws, Type W or S	7	12
37	³ / ₄ " and less	6d deformed (2"× 0.120") nail; or 8d common (2 ¹ / ₂ "× 0.131") nail	6	12
38	⁷ / ₈ " – 1"	8d common (2 ¹ / ₂ "× 0.131") nail; or 8d deformed (2 ¹ / ₂ "× 0.120") nail	6	12
39	1 ¹ / ₈ " – 1 ¹ / ₄ "	10d common (3"× 0.148") nail; or 8d deformed (2 ¹ / ₂ "× 0.120") nail	6	12

For SI: 1 inch = 25.4 mm, 1 foot = 304.8 mm, 1 mile per hour = 0.447 m/s; 1 ksi = 6.895 MPa.

a. Nails are smooth-common, box or deformed shanks except where otherwise stated. Nails used for framing and sheathing connections shall have minimum average bending yield strengths as shown: 80 ksi for shank diameter of 0.192 inch (20d common nail), 90 ksi for shank diameters larger than 0.142 inch but not larger than 0.177 inch, and 100 ksi for shank diameters of 0.142 inch or less.

b. Staples are 16 gage wire and have a minimum ⁷/₁₆ -inch on diameter crown width.

c. Nails shall be spaced at not more than 6 inches on center at all supports where spans are 48 inches or greater.

d. Four-foot by 8-foot or 4-foot by 9-foot panels shall be applied vertically.
e. Spacing of fasteners not included in this table shall be based on Table R602.3(2).
f. Where the ultimate design wind speed is 130 mph or less, nails for attaching wood structural panel roof sheathing to gable end wall framing shall be spaced 6 inches on center. Where the ultimate design wind speed is greater than 130 mph, nails for attaching panel roof sheathing to intermediate supports shall be spaced 6 inches on center for minimum 48-inch distance from ridges, eaves and gable end walls; and 4 inches on center to gable end wall framing.
f. <u>For wood structural panel roof sheathing attached to gable end roof framing and to intermediate supports within 48" of roof end zones, eaves, and ridges, nails shall be spaced at 6 inches on center where the ultimate design wind speed is less than 130 mph and shall be spaced 4 inches on center where the ultimate design wind speed is 130 mph or greater but less than 140 mph.</u>
g. Gypsum sheathing shall conform to ASTM C 1396 and shall be installed in accordance with GA 253. Fiberboard sheathing shall conform to ASTM C 208.
h. Spacing of fasteners on floor sheathing panel edges applies to panel edges supported by framing members and required blocking and at floor perimeters only. Spacing of fasteners on roof sheathing panel edges applies to panel edges supported by framing members and required blocking. Blocking of roof or floor sheathing panel edges perpendicular to the framing members need not be provided except as required by other provisions of this code. Floor perimeter shall be supported by framing members or solid blocking.
i. Where a rafter is fastened to an adjacent parallel ceiling joist in accordance with this schedule, provide two toe nails on one side of the rafter and toe nails from the ceiling joist to top plate in accordance with this schedule. The toe nail on the opposite side of the rafter shall not be required.

R803.2.3 Installation. Wood structural panel used as roof sheathing shall be installed with joints staggered or not staggered in accordance with Table R602.3(1), APA E30 for wood roof framing or with Table R804.3 for cold-formed steel roof framing. Wood structural panel roof sheathing shall not cantilever more than 9 inches beyond the gable end wall unless supported by gable overhang framing.

Reason: Nailing requirements provided in the IRC Table 602.3(1) were reviewed using loads from ASCE 7-10 *Minimum Design Loads for Buildings and Other Structures*. Nailing requirements for common species of roof framing with specific gravities of 0.42 or greater (e.g. SPF, Hem-Fir) were analyzed and it was found that the nail spacing requirements in footnote "f" needed to be slightly modified to clarify that nail spacing for all sheathing to framing attached to intermediate supports within 48" of roof end zones, eaves, and ridges must be reduced, not just at the gable end roof framing. For ultimate wind speeds of 130 mph and greater, the threshold for reducing the nail spacing from 6" to 4" in the 48" end zone areas was slightly modified while clarifying that ultimate wind speeds of 140 mph or greater are outside the scope of the IRC structural provisions. The language in footnote "f" was revised to clarify the intent of this footnote. A sentence was also added to R803.2.3 to clarify the appropriate limit on the distance unsupported sheathing can cantilever past the gable end roof framing. Tabulated calculation results based on ASCE 7-10 are provided below: (insert attachment here)

WFCM Table 3.10 [Exposure C] - Based on ASCE 7-10
Roof Sheathing Attachment Requirements for Wind Loads

700-yr. Wind Speed 3-second gust (mph)			110	115	120	130	140			
			Wood Structural Panel Sheathing							
			E	F	E	F	E	F		
Sheathing Location ¹	Rafter/Truss Framing Specific Gravity, G	Rafter/Truss Spacing (in.)	Maximum Nail Spacing for 8d Common Nails or 10d Box Nails (inches, o.c.) ²							
Interior Zone	0.42	12	6	12	6	12	6	12	6	12
		16	6	12	6	12	6	12	6	12
		19.2	6	12	6	12	6	12	6	12
		24	6	12	6	12	6	12	6	12
Perimeter Edge Zone	0.42	12	6	12	6	12	6	12	6	6
		16	6	12	6	6	6	6	6	6
		19.2	6	6	6	6	6	6	6	6
		24	6	6	6	6	6	6	4	6
Gable Endwall Rake or Rake Truss with up to 9" Rake Overhang	0.42	-	6	6	6	4	4			

E - Nail spacing at panel edges (in.)
F - Nail spacing at intermediate supports in the panel field (in.)

1 For roof sheathing within 4 feet of the perimeter edge of the roof, including 4 feet on each side of the roof peak, the 4 foot perimeter edge zone attachment requirements shall be used.
2 For wind speeds greater than 130 mph, blocking is required which transfers shear load to two additional joists.

Cost Impact: Will not increase the cost of construction

The change to footnote "f" is a clarification of the current footnote "f" intent. The 9" limit on gable overhang is not really an increase in requirement, but a limitation to allow more efficient nailing patterns.

Report of Committee Action Hearings

Committee Action:

Approved as Modified

Modify as follows:

**TABLE R602.3 (1)
FASTENING SCHEDULE**

For SI: 1 inch = 25.4 mm, 1 foot = 304.8 mm, 1 mile per hour = 0.447 m/s; 1 ksi = 6.895 MPa.

- a. Nails are smooth-common, box or deformed shanks except where otherwise stated. Nails used for framing and sheathing connections shall have minimum average bending yield strengths as shown: 80 ksi for shank diameter of 0.192 inch (20d common nail), 90 ksi for shank diameters larger than 0.142 inch but not larger than 0.177 inch, and 100 ksi for shank diameters of 0.142 inch or less.
- b. Staples are 16 gage wire and have a minimum ⁷/₁₆ -inch on diameter crown width.
- c. Nails shall be spaced at not more than 6 inches on center at all supports where spans are 48 inches or greater.
- d. Four-foot by 8-foot or 4-foot by 9-foot panels shall be applied vertically.
- e. Spacing of fasteners not included in this table shall be based on Table R602.3(2).
- f. For wood structural panel roof sheathing attached to gable end roof framing and to intermediate supports within 48" of roof-end zones, eaves, edges and ridges, nails shall be spaced at 6 inches on center where the ultimate design wind speed is less than 130 mph and shall be spaced 4 inches on center where the ultimate design wind speed is 130 mph or greater but less than 140 mph.

[←BACK](#)

g. Gypsum sheathing shall conform to ASTM C 1396 and shall be installed in accordance with GA 253. Fiberboard sheathing shall conform to ASTM C 208.

h. Spacing of fasteners on floor sheathing panel edges applies to panel edges supported by framing members and required blocking and at floor perimeters only. Spacing of fasteners on roof sheathing panel edges applies to panel edges supported by framing members and required blocking. Blocking of roof or floor sheathing panel edges perpendicular to the framing members need not be provided except as required by other provisions of this code. Floor perimeter shall be supported by framing members or solid blocking.

i. Where a rafter is fastened to an adjacent parallel ceiling joist in accordance with this schedule, provide two toe nails on one side of the rafter and toe nails from the ceiling joist to top plate in accordance with this schedule. The toe nail on the opposite side of the rafter shall not be required.

R803.2.3 Installation. Wood structural panel used as roof sheathing shall be installed with joints staggered or not staggered in accordance with Table R602.3(1), APA E30 for wood roof framing or with Table R804.3 for cold-formed steel roof framing. Wood structural panel roof sheathing in accordance with Table R503.2.1.1(1) shall not cantilever more than 9 inches beyond the gable end wall unless supported by gable overhang framing.

Committee Reason: The committee approved this change based on the proponents published reason statement. The proposal aligns the roof sheathing nail spacing with the ASCE 7-10 loading and provides an allowable cantilever for the sheathing past the gable end. The modifications deleted the terms end zones and eaves to avoid confusion with edges and added a reference to the sheathing installation table.

Assembly Action

None

Final Action Results

RB221-16

AM

[←BACK](#)Code Change No: **RB226-16**

Original Proposal

Section: R602.7, R602.7(2) (New)

Proponent: David Tyree, representing American Wood Council (dtyree@awc.org)

Revise as follows:

TABLE R602.7

GIRDER SPANS^a AND HEADER SPANS^a FOR INTERIOR BEARING WALLS (Maximum spans for Douglas fir-larch, hem-fir, southern pine and spruce-pine-fir^b and required number of jack studs)

HEADERS AND GIRDERS SUPPORTING	SIZE	BUILDING Width ^c (feet)					
		20		28		36	
		Span	NJ ^d	Span	NJ ^d	Span	NJ ^d
One floor only	2-2 x 4	3-4	1	2-8	1	2-5	1
	2-2 x 6	4-6	1	3-11	1	3-6	1
	2-2 x 8	5-9	1	5-0	2	4-5	2
	2-2 x 10	7-0	2	6-4	2	5-5	2
	2-2 x 12	8-4	2	7-0	2	6-3	2
	3-2 x 8	7-2	1	6-3	1	5-7	2
	3-2 x 10	8-9	1	7-7	2	6-9	2
	3-2 x 12	10-2	2	8-10	2	7-10	2
	4-2 x 8	9-0	1	7-8	1	6-9	1
	4-2 x 10	10-4	1	8-9	1	7-10	2
4-2 x 12	11-9	1	10-2	2	9-4	2	
Two floors	2-2 x 4	2-2	1	1-10	1	1-7	1
	2-2 x 6	3-2	2	2-9	2	2-5	2
	2-2 x 8	4-4	2	3-6	2	3-2	2
	2-2 x 10	4-11	2	4-3	2	3-10	3
	2-2 x 12	5-9	2	5-0	3	4-5	3
	3-2 x 8	5-4	2	4-5	2	3-11	2
	3-2 x 10	6-2	2	5-4	2	4-10	2
	3-2 x 12	7-2	2	6-3	2	5-7	3
	4-2 x 8	6-4	1	5-3	2	4-8	2
	4-2 x 10	7-2	2	6-2	2	5-6	2
4-2 x 12	8-4	2	7-2	2	6-5	2	

For SI: 1 inch = 25.4 mm, 1 foot = 304.8 mm.

- Spans are given in feet and inches.
- No. 1 or better grade lumber shall be used for southern pine. Other tabulated values assume #2 grade lumber.
- Building width is measured perpendicular to the ridge. For widths between those shown, spans are permitted to be interpolated.
- NJ = Number of jack studs required to support each end. Where the number of required jack studs equals one, the header is permitted to be supported by an approved framing anchor attached to the full-height wall stud and to the header.

TABLE R602.7(2)
GIRDER SPANS^a AND HEADER SPANS^a FOR INTERIOR BEARING WALLS (Maximum spans for Douglas fir-larch, hem-fir, southern pine, and spruce-pine-fir^b and required number of jack studs)

HEADERS AND GIRDERS SUPPORTING	SIZE	BUILDING Width ^c (feet)					
		12		24		36	
		Span ^e	NJ ^d	Span ^e	NJ ^d	Span ^e	NJ ^d
One floor only	2- 2x4	4 - 1	1	2 - 10	1	2 - 4	1
	2- 2x6	6 - 1	1	4 - 4	1	3 - 6	1
	2- 2x8	7 - 9	1	5 - 5	1	4 - 5	2
	2- 2x10	9 - 2	1	6 - 6	2	5 - 3	2
	2- 2x12	10 - 9	1	7 - 7	2	6 - 3	2
	3- 2x8	9 - 8	1	6 - 10	1	5 - 7	1
	3- 2x10	11 - 5	1	8 - 1	1	6 - 7	2
	3- 2x12	13 - 6	1	9 - 6	2	7 - 9	2
	4- 2x8	11 - 2	1	7 - 11	1	6 - 5	1
	4- 2x10	13 - 3	1	9 - 4	1	7 - 8	1
	4- 2x12	15 - 7	1	11 - 0	1	9 - 0	2
	Two floors	2- 2x4	2 - 7	1	1 - 11	1	1 - 7
2- 2x6		3 - 11	1	2 - 11	2	2 - 5	2
2- 2x8		5 - 0	1	3 - 8	2	3 - 1	2
2- 2x10		5 - 11	2	4 - 4	2	3 - 7	2
2- 2x12		6 - 11	2	5 - 2	2	4 - 3	3
3- 2x8		6 - 3	1	4 - 7	2	3 - 10	2
3- 2x10		7 - 5	1	5 - 6	2	4 - 6	2
3- 2x12		8 - 8	2	6 - 5	2	5 - 4	2
4- 2x8		7 - 2	1	5 - 4	1	4 - 5	2
4- 2x10		8 - 6	1	6 - 4	2	5 - 3	2
4- 2x12		10 - 1	1	7 - 5	2	6 - 2	2

For SI: 1 inch = 25.4 mm, 1 pound per square foot = 0.0479 kPa_s

a. Spans are given in feet and inches.

- b. Spans are based on minimum design properties for No. 2 grade lumber of Douglas Fir-Larch, Hem-Fir, Southern Pine, and Spruce-Pine-Fir.
- c. Building width is measured perpendicular to the ridge. For widths between those shown, spans are permitted to be interpolated.
- d. NJ - Number of jack studs required to support each end. Where the number of required jack studs equals one, the header is permitted to be supported by an approved framing anchor attached to the full-height wall stud and to the header.
- e. Spans are calculated assuming the top of the header or girder is laterally braced by perpendicular framing. Where the top of the header or girder is not laterally braced (e.g. cripple studs bearing on the header), tabulated spans for headers consisting of 2x8, 2x10, or 2x12 sizes shall be multiplied by 0.70 or the header or girder shall be designed.

Reason: The update of Table R602.7(2) Girder Spans and Header Spans for Interior Bearing Walls is proposed. Updated spans address use of Southern Pine No. 2 in lieu of Southern Pine No. 1. Footnote "e" is added to clarify that header spans are based on laterally braced assumption such as when the header is raised. For dropped headers consisting of 2x8, 2x10, or 2x12 sizes that are not laterally braced, a factor of 0.7 can be applied to determine the spans or alternatively the header or girder can be designed to include any adjustment for potential buckling. Laterally braced (raised) and not laterally braced (dropped) header conditions and building widths for which header spans are tabulated represent the same conditions used to develop header span tables in the Wood Frame Construction Manual (WFCM).

Cost Impact: Will increase the cost of construction

Increased cost may be associated with reduced spans that result from the not laterally braced condition and application of footnote e. Due to smaller building width column (12'), permissible use of Southern Pine No. 2, and the laterally braced assumption for tabulated spans, there are also cases where this change will not increase the cost of construction and may reduce cost of construction.

Report of Committee Action Hearings
--

Committee Action:

Approved as Submitted

Committee Reason: The table replaces the existing and allows the use of No. 2 grade southern pine as stated in the proponents published reason statement.

Assembly Action:

None

Final Action Results

RB226-16

AS

[←BACK](#)

[←BACK](#)

Code Change No: RB227-16

Original Proposal

Section: R602.7, R602.7(1) (New)

Proponent: David Tyree, representing American Wood Council (dtyree@awc.org)

Revise as follows:

TABLE R602.7
GIRDER SPANS* AND HEADER SPANS* FOR EXTERIOR BEARING WALLS (Maximum spans for Douglas fir-larch, hem-fir, southern pine and spruce-pine-fir* and required number of jack studs)

GIRDERS AND HEADERS SUPPORTING	SIZE	GROUND SNOW LOAD (psf) ^g																	
		30						50						70					
		Building width ^e (feet)																	
		20			28			36			20			28			36		
Span		NJ ^d	Span		NJ ^d	Span		NJ ^d	Span		NJ ^d	Span		NJ ^d	Span		NJ ^d		
Roof and ceiling	1-2 x 8	4-6	1	3-10	1	3-5	1	3-9	1	3-2	1	2-10	2	—	—	—	—		
	1-2 x 10	5-8	1	4-11	1	4-4	1	4-9	1	4-1	1	3-7	2	—	—	—	—		
	1-2 x 12	6-11	1	5-11	2	5-3	2	5-9	2	4-8	2	3-8	2	—	—	—	—		
	2-2 x 4	3-6	1	3-2	1	2-10	1	3-2	1	2-9	1	2-6	1	2-10	1	2-6	1	2-3	1
	2-2 x 6	5-5	1	4-8	1	4-2	1	4-8	1	4-1	1	3-8	2	4-2	1	3-8	2	3-3	2
	2-2 x 8	6-10	1	5-11	2	5-4	2	5-11	2	5-2	2	4-7	2	5-4	2	4-7	2	4-1	2
	2-2 x 10	8-5	2	7-3	2	6-6	2	7-3	2	6-3	2	5-7	2	6-6	2	5-7	2	5-0	2
	2-2 x 12	9-9	2	8-5	2	7-6	2	8-5	2	7-3	2	6-6	2	7-6	2	6-6	2	5-10	3
	3-2 x 8	8-4	1	7-5	1	6-8	1	7-5	1	6-5	2	5-9	2	6-8	1	5-9	2	5-2	2
	3-2 x 10	10-6	1	9-1	2	8-2	2	9-1	2	7-10	2	7-0	2	8-2	2	7-0	2	6-4	2
	3-2 x 12	12-2	2	10-7	2	9-5	2	10-7	2	9-2	2	8-2	2	9-5	2	8-2	2	7-4	2
	4-2 x 8	9-2	1	8-4	1	7-8	1	8-4	1	7-5	1	6-8	1	7-8	1	6-8	1	5-11	2
	4-2 x 10	11-8	1	10-6	1	9-5	2	10-6	1	9-1	2	8-2	2	9-5	2	8-2	2	7-3	2
4-2 x 12	14-1	1	12-2	2	10-11	2	12-2	2	10-7	2	9-5	2	10-11	2	9-5	2	8-5	2	
Roof, ceiling and one center-bearing floor	1-2 x 8	3-11	1	3-5	1	3-0	1	3-7	1	3-0	2	2-8	2	—	—	—	—		
	1-2 x 10	5-0	2	4-4	2	3-10	2	4-6	2	3-11	2	3-4	2	—	—	—	—		
	1-2 x 12	5-10	2	4-9	2	4-2	2	5-5	2	4-2	2	3-4	2	—	—	—	—		
	2-2 x 4	3-1	1	2-9	1	2-5	1	2-9	1	2-5	1	2-2	1	2-7	1	2-3	1	2-0	1
	2-2 x 6	4-6	1	4-0	1	3-7	2	4-1	1	3-7	2	3-3	2	3-9	2	3-3	2	2-11	2
	2-2 x 8	5-9	2	5-0	2	4-6	2	5-2	2	4-6	2	4-1	2	4-9	2	4-2	2	3-9	2
	2-2 x 10	7-0	2	6-2	2	5-6	2	6-4	2	5-6	2	5-0	2	5-9	2	5-1	2	4-7	3
	2-2 x 12	8-1	2	7-1	2	6-5	2	7-4	2	6-5	2	5-9	3	6-8	2	5-10	3	5-3	3
	3-2 x 8	7-2	1	6-3	2	5-8	2	6-5	2	5-8	2	5-1	2	5-11	2	5-2	2	4-8	2
	3-2 x 10	8-9	2	7-8	2	6-11	2	7-11	2	6-11	2	6-3	2	7-3	2	6-4	2	5-8	2
	3-2 x 12	10-2	2	8-11	2	8-0	2	9-2	2	8-0	2	7-3	2	8-5	2	7-4	2	6-7	2
	4-2 x 8	8-1	1	7-3	1	6-7	1	7-5	1	6-6	1	5-11	2	6-10	1	6-0	2	5-5	2
	4-2 x 10	10-1	1	8-10	2	8-0	2	9-1	2	8-0	2	7-2	2	8-4	2	7-4	2	6-7	2
4-2 x 12	11-9	2	10-3	2	9-3	2	10-7	2	9-3	2	8-4	2	9-8	2	8-6	2	7-7	2	

Roof, ceiling and one clear span floor	4-2 x 8	3-6	1	3-0	1	2-8	1	3-5	1	2-11	1	2-7	2	—	—	—	—	—	
	4-2 x 10	4-6	1	3-10	1	3-3	1	4-4	1	3-9	1	3-1	2	—	—	—	—	—	
	4-2 x 12	5-6	1	4-2	2	3-3	2	5-4	2	3-11	2	3-1	2	—	—	—	—	—	
	2-2 x 4	2-8	1	2-4	1	2-1	1	2-7	1	2-3	1	2-0	1	2-5	1	2-1	1	1-10	1
	2-2 x 6	3-11	1	3-5	2	3-0	2	3-10	2	3-4	2	3-0	2	3-6	2	3-1	2	2-9	2
	2-2 x 8	5-0	2	4-4	2	3-10	2	4-10	2	4-2	2	3-9	2	4-6	2	3-11	2	3-6	2
	2-2 x 10	6-1	2	5-3	2	4-8	2	5-11	2	5-1	2	4-7	3	5-6	2	4-9	2	4-3	3
	2-2 x 12	7-1	2	6-1	3	5-5	3	6-10	2	5-11	3	5-4	3	6-4	2	5-6	3	5-0	3
	3-2 x 8	6-3	2	5-5	2	4-10	2	6-1	2	5-3	2	4-8	2	5-7	2	4-11	2	4-5	2
	3-2 x 10	7-7	2	6-7	2	5-11	2	7-5	2	6-5	2	5-9	2	6-10	2	6-0	2	5-4	2
	3-2 x 12	8-10	2	7-8	2	6-10	2	8-7	2	7-5	2	6-8	2	7-11	2	6-11	2	6-3	2
	4-2 x 8	7-2	1	6-3	2	5-7	2	7-0	1	6-1	2	5-5	2	6-6	1	5-8	2	5-1	2
	4-2 x 10	8-9	2	7-7	2	6-10	2	8-7	2	7-5	2	6-7	2	7-11	2	6-11	2	6-2	2
	4-2 x 12	10-2	2	8-10	2	7-11	2	9-11	2	8-7	2	7-8	2	9-2	2	8-0	2	7-2	2

GIRDERS AND HEADERS SUPPORTING	SIZE	GROUND SNOW LOAD (psf) ^e																	
		30				50				70									
		Building width ^c (feet)																	
		20		28		36		20		28		36							
Span	NJ ^d	Span	NJ ^d	Span	NJ ^d	Span	NJ ^d	Span	NJ ^d	Span	NJ ^d	Span	NJ ^d	Span	NJ ^d				
Roof, ceiling and two center-bearing floors	2-2 x 4	2-7	1	2-3	1	2-0	1	2-6	1	2-2	1	1-11	1	2-4	1	2-0	1	1-9	1
	2-2 x 6	3-9	2	3-3	2	2-11	2	3-8	2	3-2	2	2-10	2	3-5	2	3-0	2	2-8	2
	2-2 x 8	4-9	2	4-2	2	3-9	2	4-7	2	4-0	2	3-8	2	4-4	2	3-9	2	3-5	2
	2-2 x 10	5-9	2	5-1	2	4-7	3	5-8	2	4-11	2	4-5	3	5-3	2	4-7	3	4-2	3
	2-2 x 12	6-8	2	5-10	3	5-3	3	6-6	2	5-9	3	5-2	3	6-1	3	5-4	3	4-10	3
	3-2 x 8	5-11	2	5-2	2	4-8	2	5-9	2	5-1	2	4-7	2	5-5	2	4-9	2	4-3	2
	3-2 x 10	7-3	2	6-4	2	5-8	2	7-1	2	6-2	2	5-7	2	6-7	2	5-9	2	5-3	2
	3-2 x 12	8-5	2	7-4	2	6-7	2	8-2	2	7-2	2	6-5	3	7-8	2	6-9	2	6-1	3
	4-2 x 8	6-10	1	6-0	2	5-5	2	6-8	1	5-10	2	5-3	2	6-3	2	5-6	2	4-11	2
	4-2 x 10	8-4	2	7-4	2	6-7	2	8-2	2	7-2	2	6-5	2	7-7	2	6-8	2	6-0	2
4-2 x 12	9-8	2	8-6	2	7-8	2	9-5	2	8-3	2	7-5	2	8-10	2	7-9	2	7-0	2	
Roof, ceiling, and two clear span floors	2-2 x 4	2-1	1	1-8	1	1-6	2	2-0	1	1-8	1	1-5	2	2-0	1	1-8	1	1-5	2
	2-2 x 6	3-1	2	2-8	2	2-4	2	3-0	2	2-7	2	2-3	2	2-11	2	2-7	2	2-3	2
	2-2 x 8	3-10	2	3-4	2	3-0	3	3-10	2	3-4	2	2-11	3	3-9	2	3-3	2	2-11	3
	2-2 x 10	4-9	2	4-1	3	3-8	3	4-8	2	4-0	3	3-7	3	4-7	3	4-0	3	3-6	3
	2-2 x 12	5-6	3	4-9	3	4-3	3	5-5	3	4-8	3	4-2	3	5-4	3	4-7	3	4-1	4
	3-2 x 8	4-10	2	4-2	2	3-9	2	4-9	2	4-1	2	3-8	2	4-8	2	4-1	2	3-8	2
	3-2 x 10	5-11	2	5-1	2	4-7	3	5-10	2	5-0	2	4-6	3	5-9	2	4-11	2	4-5	3
	3-2 x 12	6-10	2	5-11	3	5-4	3	6-9	2	5-10	3	5-3	3	6-8	2	5-9	3	5-2	3
	4-2 x 8	5-7	2	4-10	2	4-4	2	5-6	2	4-9	2	4-3	2	5-5	2	4-8	2	4-2	2
	4-2 x 10	6-10	2	5-11	2	5-3	2	6-9	2	5-10	2	5-2	2	6-7	2	5-9	2	5-1	2
4-2 x 12	7-11	2	6-10	2	6-2	3	7-9	2	6-9	2	6-0	3	7-8	2	6-8	2	5-11	3	

For SI: 1 inch = 25.4 mm, 1 pound per square foot = 0.0479 kPa.

- a. Spans are given in feet and inches.
- b. No. 1 or better grade lumber shall be used for southern pine. Other tabulated values assume #2 grade lumber.
- c. Building width is measured perpendicular to the ridge. For widths between those shown, spans are permitted to be interpolated.
- d. NJ = Number of jack studs required to support each end. Where the number of required jack studs equals one, the header is permitted to be supported by an approved framing anchor attached to the full-height wall stud and to the header.
- e. Use 30 psf ground snow load for cases in which ground snow load is less than 30 psf and the roof live load is equal to or less than 20 psf.

TABLE R602.7(1)
GIRDER SPANS^a AND HEADER SPANS^a FOR EXTERIOR BEARING WALLS (Maximum spans for Douglas fir-larch, hem-fir, southern pine, and spruce-pine-fir^b and required number of jack studs)

GIRDERS AND HEADERS SUPPORTING G	SIZE E	GROUND SNOW LOAD (psf) ^e																	
		30						50						70					
		Building width ^c (feet)																	
		12		24		36		12		24		36		12		24		36	
Span f	NJ d	Span f	NJ d	Span f	NJ d	Span f	NJ d	Span f	NJ d	Span f	NJ d	Span f	NJ d	Span f	NJ d	Span f	NJ d		
Roof and ceiling	1-2x6	4-0	1	3-1	2	2-7	2	3-5	1	2-8	2	2-3	2	3-0	2	2-4	2	2-0	2
	1-2x8	5-1	2	3-11	2	3-3	2	4-4	2	3-4	2	2-10	2	3-10	2	3-0	2	2-6	3
	1-2x10	6-0	2	4-8	2	3-11	2	5-2	2	4-0	2	3-4	3	4-7	2	3-6	3	3-0	3
	1-2x12	7-1	2	5-5	2	4-7	3	6-1	2	4-8	3	3-11	3	5-5	2	4-2	3	3-6	3
	2-2x4	4-0	1	3-1	1	2-7	1	3-5	1	2-7	1	2-2	1	3-0	1	2-4	1	2-0	1
	2-2x6	6-0	1	4-7	1	3-10	1	5-1	1	3-11	1	3-3	2	4-6	1	3-6	2	2-11	2
	2-2x8	7-7	1	5-9	1	4-10	2	6-5	1	5-0	2	4-2	2	5-9	1	4-5	2	3-9	2
	2-2x10	9-0	1	6-10	2	5-9	2	7-8	2	5-11	2	4-11	2	6-9	2	5-3	2	4-5	2
	2-2x12	10-7	2	8-1	2	6-10	2	9-0	2	6-11	2	5-10	2	8-0	2	6-2	2	5-2	3
	3-2x8	9-5	1	7-3	1	6-1	1	8-1	1	6-3	1	5-3	2	7-2	1	5-6	2	4-8	2
	3-2x10	11-3	1	8-7	1	7-3	2	9-7	1	7-4	2	6-2	2	8-6	1	6-7	2	5-6	2
	3-2x12	13-2	1	10-1	2	8-6	2	11-3	2	8-8	2	7-4	2	10-0	2	7-9	2	6-6	2
	4-2x8	10-11	1	8-4	1	7-0	1	9-4	1	7-2	1	6-0	1	8-3	1	6-4	1	5-4	2
	4-2x10	12-11	1	9-11	1	8-4	1	11-1	1	8-6	1	7-2	2	9-10	1	7-7	2	6-4	2
	4-2x12	15-3	1	11-8	1	9-10	2	13-0	1	10-0	2	8-5	2	11-7	1	8-11	2	7-6	2
Roof, ceiling and one center-bearing floor	1-2x6	3-3	1	2-7	2	2-2	2	3-0	2	2-4	2	2-0	2	2-9	2	2-2	2	1-10	2
	1-2x8	4-1	2	3-3	2	2-9	2	3-9	2	3-0	2	2-6	3	3-6	2	2-9	2	2-4	3
	1-	4-	2	3-	2	3-3	3	4-6	2	3-6	3	3-0	3	4-1	2	3-3	3	2-9	3

	$\frac{2x1}{0}$	<u>11</u>		<u>10</u>															
	$\frac{1-2x1}{2}$	<u>5-9</u>	<u>2</u>	<u>4-6</u>	<u>3</u>	$\frac{3-10}{10}$	<u>3</u>	<u>5-3</u>	<u>2</u>	<u>4-2</u>	<u>3</u>	<u>3-6</u>	<u>3</u>	$\frac{4-10}{10}$	<u>3</u>	$\frac{3-10}{10}$	<u>3</u>	<u>3-3</u>	<u>4</u>
	$\frac{2-2x4}{2}$	<u>3-3</u>	<u>1</u>	<u>2-6</u>	<u>1</u>	<u>2-2</u>	<u>1</u>	<u>3-0</u>	<u>1</u>	<u>2-4</u>	<u>1</u>	<u>2-0</u>	<u>1</u>	<u>2-8</u>	<u>1</u>	<u>2-2</u>	<u>1</u>	$\frac{1-10}{10}$	<u>1</u>
	$\frac{2-2x6}{2}$	$\frac{4-10}{10}$	<u>1</u>	<u>3-9</u>	<u>1</u>	<u>3-3</u>	<u>2</u>	<u>4-5</u>	<u>1</u>	<u>3-6</u>	<u>2</u>	<u>3-0</u>	<u>2</u>	<u>4-1</u>	<u>1</u>	<u>3-3</u>	<u>2</u>	<u>2-9</u>	<u>2</u>
	$\frac{2-2x8}{2}$	<u>6-1</u>	<u>1</u>	$\frac{4-10}{10}$	<u>2</u>	<u>4-1</u>	<u>2</u>	<u>5-7</u>	<u>2</u>	<u>4-5</u>	<u>2</u>	<u>3-9</u>	<u>2</u>	<u>5-2</u>	<u>2</u>	<u>4-1</u>	<u>2</u>	<u>3-6</u>	<u>2</u>
	$\frac{2-2x1}{0}$	<u>7-3</u>	<u>2</u>	<u>5-8</u>	<u>2</u>	$\frac{4-10}{10}$	<u>2</u>	<u>6-8</u>	<u>2</u>	<u>5-3</u>	<u>2</u>	<u>4-5</u>	<u>2</u>	<u>6-1</u>	<u>2</u>	$\frac{4-10}{10}$	<u>2</u>	<u>4-1</u>	<u>2</u>
	$\frac{2-2x1}{2}$	<u>8-6</u>	<u>2</u>	<u>6-8</u>	<u>2</u>	<u>5-8</u>	<u>2</u>	$\frac{7-10}{10}$	<u>2</u>	<u>6-2</u>	<u>2</u>	<u>5-3</u>	<u>3</u>	<u>7-2</u>	<u>2</u>	<u>5-8</u>	<u>2</u>	$\frac{4-10}{10}$	<u>3</u>
	$\frac{3-2x8}{2}$	<u>7-8</u>	<u>1</u>	<u>6-0</u>	<u>1</u>	<u>5-1</u>	<u>2</u>	<u>7-0</u>	<u>1</u>	<u>5-6</u>	<u>2</u>	<u>4-8</u>	<u>2</u>	<u>6-5</u>	<u>1</u>	<u>5-1</u>	<u>2</u>	<u>4-4</u>	<u>2</u>
	$\frac{3-2x1}{0}$	<u>9-1</u>	<u>1</u>	<u>7-2</u>	<u>2</u>	<u>6-1</u>	<u>2</u>	<u>8-4</u>	<u>1</u>	<u>6-7</u>	<u>2</u>	<u>5-7</u>	<u>2</u>	<u>7-8</u>	<u>2</u>	<u>6-1</u>	<u>2</u>	<u>5-2</u>	<u>2</u>
	$\frac{3-2x1}{2}$	$\frac{10-8}{8}$	<u>2</u>	<u>8-5</u>	<u>2</u>	<u>7-2</u>	<u>2</u>	$\frac{9-10}{10}$	<u>2</u>	<u>7-8</u>	<u>2</u>	<u>6-7</u>	<u>2</u>	<u>9-0</u>	<u>2</u>	<u>7-1</u>	<u>2</u>	<u>6-1</u>	<u>2</u>
	$\frac{4-2x8}{2}$	$\frac{8-10}{10}$	<u>1</u>	$\frac{6-11}{11}$	<u>1</u>	$\frac{5-11}{11}$	<u>1</u>	<u>8-1</u>	<u>1</u>	<u>6-4</u>	<u>1</u>	<u>5-5</u>	<u>2</u>	<u>7-5</u>	<u>1</u>	$\frac{5-11}{11}$	<u>1</u>	<u>5-0</u>	<u>2</u>
	$\frac{4-2x1}{0}$	$\frac{10-6}{6}$	<u>1</u>	<u>8-3</u>	<u>2</u>	<u>7-0</u>	<u>2</u>	<u>9-8</u>	<u>1</u>	<u>7-7</u>	<u>2</u>	<u>6-5</u>	<u>2</u>	$\frac{8-10}{10}$	<u>1</u>	<u>7-0</u>	<u>2</u>	<u>6-0</u>	<u>2</u>
	$\frac{4-2x1}{2}$	$\frac{12-4}{4}$	<u>1</u>	<u>9-8</u>	<u>2</u>	<u>8-3</u>	<u>2</u>	$\frac{11-4}{4}$	<u>2</u>	$\frac{8-11}{11}$	<u>2</u>	<u>7-7</u>	<u>2</u>	$\frac{10-4}{4}$	<u>2</u>	<u>8-3</u>	<u>2</u>	<u>7-0</u>	<u>2</u>
Roof, ceiling and one clear span floor	$\frac{1-2x6}{2}$	$\frac{2-11}{11}$	<u>2</u>	<u>2-3</u>	<u>2</u>	$\frac{1-11}{11}$	<u>2</u>	<u>2-9</u>	<u>2</u>	<u>2-1</u>	<u>2</u>	<u>1-9</u>	<u>2</u>	<u>2-7</u>	<u>2</u>	<u>2-0</u>	<u>2</u>	<u>1-8</u>	<u>2</u>
	$\frac{1-2x8}{2}$	<u>3-9</u>	<u>2</u>	$\frac{2-10}{10}$	<u>2</u>	<u>2-5</u>	<u>3</u>	<u>3-6</u>	<u>2</u>	<u>2-8</u>	<u>2</u>	<u>2-3</u>	<u>3</u>	<u>3-3</u>	<u>2</u>	<u>2-6</u>	<u>3</u>	<u>2-2</u>	<u>3</u>
	$\frac{1-2x1}{0}$	<u>4-5</u>	<u>2</u>	<u>3-5</u>	<u>3</u>	$\frac{2-10}{10}$	<u>3</u>	<u>4-2</u>	<u>2</u>	<u>3-2</u>	<u>3</u>	<u>2-8</u>	<u>3</u>	$\frac{3-11}{11}$	<u>2</u>	<u>3-0</u>	<u>3</u>	<u>2-6</u>	<u>3</u>
	$\frac{1-2x1}{2}$	<u>5-2</u>	<u>2</u>	<u>4-0</u>	<u>3</u>	<u>3-4</u>	<u>3</u>	$\frac{4-10}{10}$	<u>3</u>	<u>3-9</u>	<u>3</u>	<u>3-2</u>	<u>4</u>	<u>4-7</u>	<u>3</u>	<u>3-6</u>	<u>3</u>	<u>3-0</u>	<u>4</u>
	$\frac{2-2x4}{2}$	$\frac{2-11}{11}$	<u>1</u>	<u>2-3</u>	<u>1</u>	$\frac{1-10}{10}$	<u>1</u>	<u>2-9</u>	<u>1</u>	<u>2-1</u>	<u>1</u>	<u>1-9</u>	<u>1</u>	<u>2-7</u>	<u>1</u>	<u>2-0</u>	<u>1</u>	<u>1-8</u>	<u>1</u>
	$\frac{2-2x6}{2}$	<u>4-4</u>	<u>1</u>	<u>3-4</u>	<u>2</u>	$\frac{2-10}{10}$	<u>2</u>	<u>4-1</u>	<u>1</u>	<u>3-2</u>	<u>2</u>	<u>2-8</u>	<u>2</u>	$\frac{3-10}{10}$	<u>1</u>	<u>3-0</u>	<u>2</u>	<u>2-6</u>	<u>2</u>
	$\frac{2-2x8}{2}$	<u>5-6</u>	<u>2</u>	<u>4-3</u>	<u>2</u>	<u>3-7</u>	<u>2</u>	<u>5-2</u>	<u>2</u>	<u>4-0</u>	<u>2</u>	<u>3-4</u>	<u>2</u>	$\frac{4-10}{10}$	<u>2</u>	<u>3-9</u>	<u>2</u>	<u>3-2</u>	<u>2</u>
	$\frac{2-2x1}{0}$	<u>6-7</u>	<u>2</u>	<u>5-0</u>	<u>2</u>	<u>4-2</u>	<u>2</u>	<u>6-1</u>	<u>2</u>	<u>4-9</u>	<u>2</u>	<u>4-0</u>	<u>2</u>	<u>5-9</u>	<u>2</u>	<u>4-5</u>	<u>2</u>	<u>3-9</u>	<u>3</u>
	$\frac{2-2x1}{2}$	<u>7-9</u>	<u>2</u>	$\frac{5-11}{11}$	<u>2</u>	$\frac{4-11}{11}$	<u>3</u>	<u>7-2</u>	<u>2</u>	<u>5-7</u>	<u>2</u>	<u>4-8</u>	<u>3</u>	<u>6-9</u>	<u>2</u>	<u>5-3</u>	<u>3</u>	<u>4-5</u>	<u>3</u>

	<u>2</u>																		
	<u>3-2x8</u>	<u>6-11</u>	1	<u>5-3</u>	<u>2</u>	<u>4-5</u>	<u>2</u>	<u>6-5</u>	1	<u>5-0</u>	<u>2</u>	<u>4-2</u>	<u>2</u>	<u>6-1</u>	1	<u>4-8</u>	<u>2</u>	<u>4-0</u>	<u>2</u>
	<u>3-2x10</u>	<u>8-3</u>	<u>2</u>	<u>6-3</u>	<u>2</u>	<u>5-3</u>	<u>2</u>	<u>7-8</u>	<u>2</u>	<u>5-11</u>	<u>2</u>	<u>5-0</u>	<u>2</u>	<u>7-3</u>	<u>2</u>	<u>5-7</u>	<u>2</u>	<u>4-8</u>	<u>2</u>
	<u>3-2x12</u>	<u>9-8</u>	<u>2</u>	<u>7-5</u>	<u>2</u>	<u>6-2</u>	<u>2</u>	<u>9-0</u>	<u>2</u>	<u>7-0</u>	<u>2</u>	<u>5-10</u>	<u>2</u>	<u>8-6</u>	<u>2</u>	<u>6-7</u>	<u>2</u>	<u>5-6</u>	<u>3</u>
	<u>4-2x8</u>	<u>8-0</u>	1	<u>6-1</u>	1	<u>5-1</u>	<u>2</u>	<u>7-5</u>	1	<u>5-9</u>	<u>2</u>	<u>4-10</u>	<u>2</u>	<u>7-0</u>	1	<u>5-5</u>	<u>2</u>	<u>4-7</u>	<u>2</u>
	<u>4-2x10</u>	<u>9-6</u>	1	<u>7-3</u>	<u>2</u>	<u>6-1</u>	<u>2</u>	<u>8-10</u>	1	<u>6-10</u>	<u>2</u>	<u>5-9</u>	<u>2</u>	<u>8-4</u>	1	<u>6-5</u>	<u>2</u>	<u>5-5</u>	<u>2</u>
	<u>4-2x12</u>	<u>11-2</u>	<u>2</u>	<u>8-6</u>	<u>2</u>	<u>7-2</u>	<u>2</u>	<u>10-5</u>	<u>2</u>	<u>8-0</u>	<u>2</u>	<u>6-9</u>	<u>2</u>	<u>9-10</u>	<u>2</u>	<u>7-7</u>	<u>2</u>	<u>6-5</u>	<u>2</u>
Roof, ceiling and two center-bearing floors	<u>1-2x6</u>	<u>2-8</u>	<u>2</u>	<u>2-1</u>	<u>2</u>	<u>1-10</u>	<u>2</u>	<u>2-7</u>	<u>2</u>	<u>2-0</u>	<u>2</u>	<u>1-9</u>	<u>2</u>	<u>2-5</u>	<u>2</u>	<u>1-11</u>	<u>2</u>	<u>1-8</u>	<u>2</u>
	<u>1-2x8</u>	<u>3-5</u>	<u>2</u>	<u>2-8</u>	<u>2</u>	<u>2-4</u>	3	<u>3-3</u>	<u>2</u>	<u>2-7</u>	<u>2</u>	<u>2-2</u>	3	<u>3-1</u>	<u>2</u>	<u>2-5</u>	3	<u>2-1</u>	3
	<u>1-2x10</u>	<u>4-0</u>	<u>2</u>	<u>3-2</u>	3	<u>2-9</u>	3	<u>3-10</u>	<u>2</u>	<u>3-1</u>	3	<u>2-7</u>	3	<u>3-8</u>	<u>2</u>	<u>2-11</u>	3	<u>2-5</u>	3
	<u>1-2x12</u>	<u>4-9</u>	3	<u>3-9</u>	3	<u>3-2</u>	4	<u>4-6</u>	3	<u>3-7</u>	3	<u>3-1</u>	4	<u>4-3</u>	3	<u>3-5</u>	3	<u>2-11</u>	4
	<u>2-2x4</u>	<u>2-8</u>	1	<u>2-1</u>	1	<u>1-9</u>	1	<u>2-6</u>	1	<u>2-0</u>	1	<u>1-8</u>	1	<u>2-5</u>	1	<u>1-11</u>	1	<u>1-7</u>	1
	<u>2-2x6</u>	<u>4-0</u>	1	<u>3-2</u>	<u>2</u>	<u>2-8</u>	<u>2</u>	<u>3-9</u>	1	<u>3-0</u>	<u>2</u>	<u>2-7</u>	<u>2</u>	<u>3-7</u>	1	<u>2-10</u>	<u>2</u>	<u>2-5</u>	<u>2</u>
	<u>2-2x8</u>	<u>5-0</u>	<u>2</u>	<u>4-0</u>	<u>2</u>	<u>3-5</u>	<u>2</u>	<u>4-10</u>	<u>2</u>	<u>3-10</u>	<u>2</u>	<u>3-3</u>	<u>2</u>	<u>4-7</u>	<u>2</u>	<u>3-7</u>	<u>2</u>	<u>3-1</u>	<u>2</u>
	<u>2-2x10</u>	<u>6-0</u>	<u>2</u>	<u>4-9</u>	<u>2</u>	<u>4-0</u>	<u>2</u>	<u>5-8</u>	<u>2</u>	<u>4-6</u>	<u>2</u>	<u>3-10</u>	3	<u>5-5</u>	<u>2</u>	<u>4-3</u>	<u>2</u>	<u>3-8</u>	3
	<u>2-2x12</u>	<u>7-0</u>	<u>2</u>	<u>5-7</u>	<u>2</u>	<u>4-9</u>	3	<u>6-8</u>	<u>2</u>	<u>5-4</u>	3	<u>4-6</u>	3	<u>6-4</u>	<u>2</u>	<u>5-0</u>	3	<u>4-3</u>	3
	<u>3-2x8</u>	<u>6-4</u>	1	<u>5-0</u>	<u>2</u>	<u>4-3</u>	<u>2</u>	<u>6-0</u>	1	<u>4-9</u>	<u>2</u>	<u>4-1</u>	<u>2</u>	<u>5-8</u>	<u>2</u>	<u>4-6</u>	<u>2</u>	<u>3-10</u>	<u>2</u>
	<u>3-2x10</u>	<u>7-6</u>	<u>2</u>	<u>5-11</u>	<u>2</u>	<u>5-1</u>	<u>2</u>	<u>7-1</u>	<u>2</u>	<u>5-8</u>	<u>2</u>	<u>4-10</u>	<u>2</u>	<u>6-9</u>	<u>2</u>	<u>5-4</u>	<u>2</u>	<u>4-7</u>	<u>2</u>
	<u>3-2x12</u>	<u>8-10</u>	<u>2</u>	<u>7-0</u>	<u>2</u>	<u>5-11</u>	<u>2</u>	<u>8-5</u>	<u>2</u>	<u>6-8</u>	<u>2</u>	<u>5-8</u>	3	<u>8-0</u>	<u>2</u>	<u>6-4</u>	<u>2</u>	<u>5-4</u>	3
	<u>4-2x8</u>	<u>7-3</u>	1	<u>5-9</u>	1	<u>4-11</u>	<u>2</u>	<u>6-11</u>	1	<u>5-6</u>	<u>2</u>	<u>4-8</u>	<u>2</u>	<u>6-7</u>	1	<u>5-2</u>	<u>2</u>	<u>4-5</u>	<u>2</u>
	<u>4-2x10</u>	<u>8-8</u>	1	<u>6-10</u>	<u>2</u>	<u>5-10</u>	<u>2</u>	<u>8-3</u>	<u>2</u>	<u>6-6</u>	<u>2</u>	<u>5-7</u>	<u>2</u>	<u>7-10</u>	<u>2</u>	<u>6-2</u>	<u>2</u>	<u>5-3</u>	<u>2</u>
	<u>4-2x12</u>	<u>10-2</u>	<u>2</u>	<u>8-1</u>	<u>2</u>	<u>6-10</u>	<u>2</u>	<u>9-8</u>	<u>2</u>	<u>7-8</u>	<u>2</u>	<u>6-7</u>	<u>2</u>	<u>9-2</u>	<u>2</u>	<u>7-3</u>	<u>2</u>	<u>6-2</u>	<u>2</u>

	<u>2</u>																		
Roof, ceiling and two clear span floors	<u>1-2x6</u>	<u>2-3</u>	<u>2</u>	<u>1-9</u>	<u>2</u>	<u>1-5</u>	<u>2</u>	<u>2-3</u>	<u>2</u>	<u>1-9</u>	<u>2</u>	<u>1-5</u>	<u>3</u>	<u>2-2</u>	<u>2</u>	<u>1-8</u>	<u>2</u>	<u>1-5</u>	<u>3</u>
	<u>1-2x8</u>	<u>2-10</u>	<u>2</u>	<u>2-2</u>	<u>3</u>	<u>1-10</u>	<u>3</u>	<u>2-10</u>	<u>2</u>	<u>2-2</u>	<u>3</u>	<u>1-10</u>	<u>3</u>	<u>2-9</u>	<u>2</u>	<u>2-1</u>	<u>3</u>	<u>1-10</u>	<u>3</u>
	<u>1-2x10</u>	<u>3-4</u>	<u>2</u>	<u>2-7</u>	<u>3</u>	<u>2-2</u>	<u>3</u>	<u>3-4</u>	<u>3</u>	<u>2-7</u>	<u>3</u>	<u>2-2</u>	<u>4</u>	<u>3-3</u>	<u>3</u>	<u>2-6</u>	<u>3</u>	<u>2-2</u>	<u>4</u>
	<u>1-2x12</u>	<u>4-0</u>	<u>3</u>	<u>3-0</u>	<u>3</u>	<u>2-7</u>	<u>4</u>	<u>4-0</u>	<u>3</u>	<u>3-0</u>	<u>4</u>	<u>2-7</u>	<u>4</u>	<u>3-10</u>	<u>3</u>	<u>3-0</u>	<u>4</u>	<u>2-6</u>	<u>4</u>
	<u>2-2x4</u>	<u>2-3</u>	<u>1</u>	<u>1-8</u>	<u>1</u>	<u>1-4</u>	<u>1</u>	<u>2-3</u>	<u>1</u>	<u>1-8</u>	<u>1</u>	<u>1-4</u>	<u>1</u>	<u>2-2</u>	<u>1</u>	<u>1-8</u>	<u>1</u>	<u>1-4</u>	<u>2</u>
	<u>2-2x6</u>	<u>3-4</u>	<u>1</u>	<u>2-6</u>	<u>2</u>	<u>2-2</u>	<u>2</u>	<u>3-4</u>	<u>2</u>	<u>2-6</u>	<u>2</u>	<u>2-2</u>	<u>2</u>	<u>3-3</u>	<u>2</u>	<u>2-6</u>	<u>2</u>	<u>2-1</u>	<u>2</u>
	<u>2-2x8</u>	<u>4-3</u>	<u>2</u>	<u>3-3</u>	<u>2</u>	<u>2-8</u>	<u>2</u>	<u>4-3</u>	<u>2</u>	<u>3-3</u>	<u>2</u>	<u>2-8</u>	<u>2</u>	<u>4-1</u>	<u>2</u>	<u>3-2</u>	<u>2</u>	<u>2-8</u>	<u>3</u>
	<u>2-2x10</u>	<u>5-0</u>	<u>2</u>	<u>3-10</u>	<u>2</u>	<u>3-2</u>	<u>3</u>	<u>5-0</u>	<u>2</u>	<u>3-10</u>	<u>2</u>	<u>3-2</u>	<u>3</u>	<u>4-10</u>	<u>2</u>	<u>3-9</u>	<u>3</u>	<u>3-2</u>	<u>3</u>
	<u>2-2x12</u>	<u>5-11</u>	<u>2</u>	<u>4-6</u>	<u>3</u>	<u>3-9</u>	<u>3</u>	<u>5-11</u>	<u>2</u>	<u>4-6</u>	<u>3</u>	<u>3-9</u>	<u>3</u>	<u>5-8</u>	<u>2</u>	<u>4-5</u>	<u>3</u>	<u>3-9</u>	<u>3</u>
	<u>3-2x8</u>	<u>5-3</u>	<u>1</u>	<u>4-0</u>	<u>2</u>	<u>3-5</u>	<u>2</u>	<u>5-3</u>	<u>2</u>	<u>4-0</u>	<u>2</u>	<u>3-5</u>	<u>2</u>	<u>5-1</u>	<u>2</u>	<u>3-11</u>	<u>2</u>	<u>3-4</u>	<u>2</u>
	<u>3-2x10</u>	<u>6-3</u>	<u>2</u>	<u>4-9</u>	<u>2</u>	<u>4-0</u>	<u>2</u>	<u>6-3</u>	<u>2</u>	<u>4-9</u>	<u>2</u>	<u>4-0</u>	<u>2</u>	<u>6-1</u>	<u>2</u>	<u>4-8</u>	<u>2</u>	<u>4-0</u>	<u>3</u>
	<u>3-2x12</u>	<u>7-5</u>	<u>2</u>	<u>5-8</u>	<u>2</u>	<u>4-9</u>	<u>3</u>	<u>7-5</u>	<u>2</u>	<u>5-8</u>	<u>2</u>	<u>4-9</u>	<u>3</u>	<u>7-2</u>	<u>2</u>	<u>5-6</u>	<u>3</u>	<u>4-8</u>	<u>3</u>
	<u>4-2x8</u>	<u>6-1</u>	<u>1</u>	<u>4-8</u>	<u>2</u>	<u>3-11</u>	<u>2</u>	<u>6-1</u>	<u>1</u>	<u>4-8</u>	<u>2</u>	<u>3-11</u>	<u>2</u>	<u>5-11</u>	<u>1</u>	<u>4-7</u>	<u>2</u>	<u>3-10</u>	<u>2</u>
	<u>4-2x10</u>	<u>7-3</u>	<u>2</u>	<u>5-6</u>	<u>2</u>	<u>4-8</u>	<u>2</u>	<u>7-3</u>	<u>2</u>	<u>5-6</u>	<u>2</u>	<u>4-8</u>	<u>2</u>	<u>7-0</u>	<u>2</u>	<u>5-5</u>	<u>2</u>	<u>4-7</u>	<u>2</u>
	<u>4-2x12</u>	<u>8-6</u>	<u>2</u>	<u>6-6</u>	<u>2</u>	<u>5-6</u>	<u>2</u>	<u>8-6</u>	<u>2</u>	<u>6-6</u>	<u>2</u>	<u>5-6</u>	<u>2</u>	<u>8-3</u>	<u>2</u>	<u>6-4</u>	<u>2</u>	<u>5-4</u>	<u>3</u>

For SI: 1 inch = 25.4 mm, 1 pound per square foot = 0.0479 kPa.

- a. Spans are given in feet and inches.
- b. Spans are based on minimum design properties for No. 2 grade lumber of Douglas Fir-Larch, Hem-Fir, Southern Pine, and Spruce-Pine-Fir.
- c. Building width is measured perpendicular to the ridge. For widths between those shown, spans are permitted to be interpolated.
- d. NJ - Number of jack studs required to support each end. Where the number of required jack studs equals one, the header is permitted to be supported by an approved framing anchor attached to the full-height wall stud and to the header.
- e. Use 30 psf ground snow load for cases in which ground snow load is less than 30 psf and the roof live load is equal to or less than 20 psf.
- f. Spans are calculated assuming the top of the header or girder is laterally braced by perpendicular framing. Where the top of the header or girder is not laterally braced (e.g. cripple studs bearing on the header), tabulated spans for headers consisting of 2x8, 2x10, or 2x12 sizes shall be multiplied by 0.70 or the header or girder shall be designed.

Reason: The update of Table R602.7(1) Girder Spans and Header Spans for Exterior Bearing Walls is proposed. Updated spans address use of Southern Pine No. 2 in lieu of Southern Pine No. 1. Footnote "e" is added to clarify that header spans are based on laterally braced assumption such as when the header is raised. For dropped headers consisting of 2x8, 2x10, or 2x12 sizes that are not laterally braced, a factor of 0.7 can be applied to determine the spans or alternatively the header or girder can be designed to include any adjustment for potential buckling. Laterally braced (raised) and not laterally braced (dropped) header

conditions and building widths for which header spans are tabulated represent the same conditions used to develop header span tables in the Wood Frame Construction Manual (WFCM).

Cost Impact: Will increase the cost of construction
Increased cost may be associated with reduced spans that result from the not laterally braced condition and application of footnote f. Due to smaller building width column (12'), permissible use of Southern Pine No. 2, and the laterally braced assumption for tabulated spans, there are also cases where this change will not increase the cost of construction and may reduce cost of construction.

Report of Committee Action Hearings

Committee Action: **Approved as Submitted**

Committee Reason: Consistent with prior action on RB226-16. Updates the table to allow No.2 southern pine.

Assembly Action: **None**

Final Action Results

RB227-16 **AS**

Code Change No: **RB228-16**

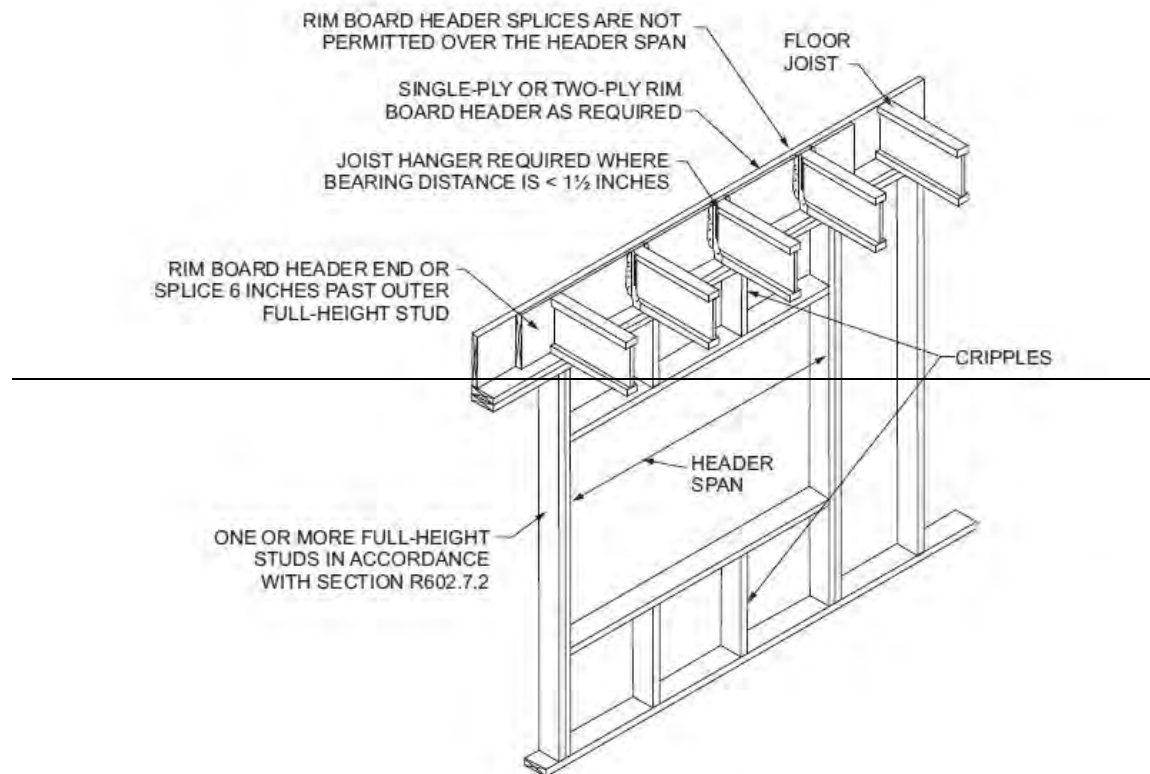
Original Proposal

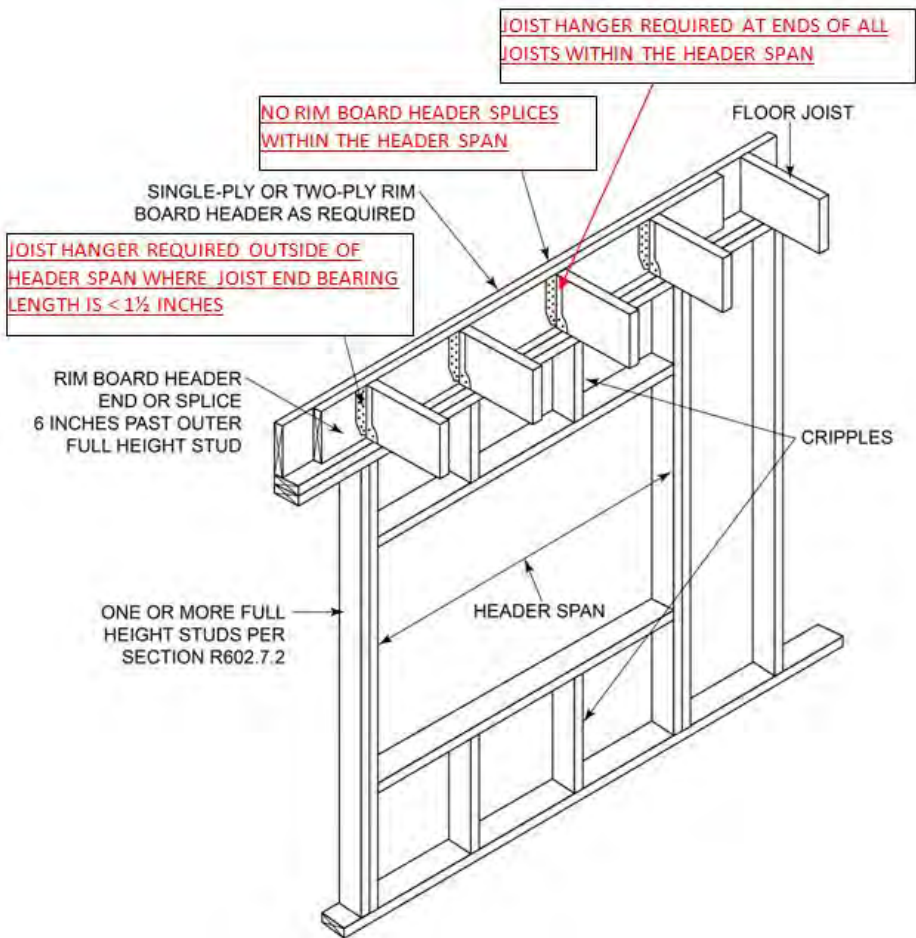
Section: R602.7.2

Proponent: Matthew Hunter, representing American Wood Council (mhunter@awc.org)

Revise as follows:

**FIGURE R602.7.2
RIM BOARD HEADER CONSTRUCTION**





For SI: 25.4 mm = 1 inch.

Reason: This figure revision clarifies requirements for joist hangers in rim board header applications. Joist hangers are always required for attachment of joist to header over the header span to ensure that the load is not transferred to the unsupported portion of the top plate. Joist ends that bear on the portion of the top plate that is directly supported below by full height studs, and with a bearing length of 1.5" or greater, do not require the use of joist hangers.

Cost Impact: Will not increase the cost of construction

This revision corrects the illustration detail in the previous code edition, and is primarily editorial in nature. Therefore, no increased cost are associated with this change.

Report of Committee Action Hearings

Committee Action:

Approved as Submitted

Committee Reason: The committee approved this proposal base on the proponents published reason statement.

Assembly Action:

None

Final Action Results

RB228-16

AS

Code Change No: **RB229-16**

Original Proposal

Section: R602.7.5

Proponent: Paul Coats, PE CBO, representing American Wood Council (pcoats@awc.org)

Revise as follows:

R602.7.5 Supports for headers. Headers shall be supported on each end with one or more jack studs or with approved framing anchors in accordance with Table R602.7(1) or R602.7(2). The full-height stud adjacent to each end of the header shall be end nailed to each end of the header with four-16d nails (3.5 inches x 0.135 inches). The minimum number of full-height studs at each end of a header shall be in accordance with Table R602.7.5.

TABLE R602.7.5
MINIMUM NUMBER OF FULL HEIGHT STUDS AT EACH END OF HEADERS IN EXTERIOR WALLS^a

HEADER SPAN- (feet)	MAXIMUM STUD SPACING (inches)- [per Table R602.3(5)]	
	16	24
≤3'	4	4
4'	2	4
8'	3	2
12'	5	3
16'	6	4

MAXIMUM HEADER SPAN (feet)	ULTIMATE DESIGN WIND SPEED AND EXPOSURE CATEGORY	
	< 140 mph, Exposure B or < 130 mph, Exposure C	≤ 115 mph, Exposure B^b
4	1	1
6	2	1
8	2	1
10	3	2
12	3	2
14	3	2
16	4	2
18	4	2

a. For header spans between those given above, use the minimum number of full-height studs associated with the larger header span.

b. The tabulated minimum number of full-height studs is applicable where jack studs are provided to support the header at each end in accordance with Table R602.7.1(1). Where a framing anchor is used to support the header in lieu of a jack stud in accordance with footnote "d" of Table R602.7.1(1), the minimum number of full-height studs at each end of a header shall be in accordance with requirements for wind speed < 140 mph, Exposure B.

Reason: This change simplifies the full height stud (e.g. king stud) table while also removing conservatism and limited applicability of the 16" maximum stud spacing case. The number of full-height studs is based on out-of-plane wind resistance provided by the stud to plate nailing. The connection resistance has been increased from prior code editions based on RB272-13, approved last cycle. Wind loads are based on an assumption that full-height studs on either side of the opening carry 100% of the out-of-plane wind loads. Reference conditions for the calculations assume a 9' wall height and wall Zone 4 pressures for header spans greater

than 6 feet and wall Zone 5 pressures for header spans less than 6 feet. The number of full height studs required by calculation is limited to the maximum number displaced by the opening. Footnote "a" clarifies that the number of full-height studs for intermediate header spans is based on the next larger header span. Footnote "b" provides a basic assumption of the tabulated requirements-- that headers are supported at each end by jack studs. When jack stud support is not provided, such as when an approved anchor is used in lieu of a jack stud, the full height stud on either side of the opening is carrying both out-of-plane wind loads and gravity loads. For that case, footnote "b" indicates that the < 140 mph Exposure B column associated with the number of studs displaced by the opening is applicable. The reduced number of full-height studs associated with 115 mph Exposure B applies only in those lower wind pressure areas where jack stud support is provided to the header at each end.

Cost Impact: Will not increase the cost of construction

The proposed table will require less full-height studs than are currently required in some circumstances, and will never require more than are currently required. Therefore the cost of construction will not increase.

Report of Committee Action Hearings
--

Committee Action:

Approved as Submitted

Committee Reason: The committee approved this proposal based on the proponents published reason statement. The column headers should be reversed with ≤ 115 mph on the left and the right hand side should show > 115 mph but less than 140 mph, Exposure B or 130 mph, Exposure C.

Assembly Action:

None

Final Action Results

RB229-16

AS

[←BACK](#)

Code Change No: **RB230-16**

Original Proposal

Section: R602, R602.10.10, R602.10.3

Proponent: Charles Bajnai, representing Chesterfield County, VA (bajnaic@chesterfield.gov); Bradford Douglas (bdouglas@awc.org); Gary Ehrlich (gehrlich@nahb.org)

Revise as follow:

TABLE R602.10.3 (2)
WIND ADJUSTMENT FACTORS TO THE REQUIRED LENGTH OF WALL BRACING

ITEM NUMBER	ADJUSTMENT BASED ON	STORY/SUPPORTING	CONDITION	ADJUSTMENT FACTOR ^{a, b} [multiply length from Table R602.10.3(1) by this factor]	APPLICABLE METHODS
1	Exposure category	One-story structure	B	1.00	All methods
			C	1.20	
			D	1.50	
		Two-story structure	B	1.00	
			C	1.30	
			D	1.60	
		Three-story structure	B	1.00	
			C	1.40	
			D	1.70	
2	Roof eave-to-ridge height	Roof only	≤ 5 feet	0.70	
			10 feet	1.00	
			15 feet	1.30	
			20 feet	1.60	
		Roof + 1 floor	≤ 5 feet	0.85	
			10 feet	1.00	
			15 feet	1.15	
			20 feet	1.30	
		Roof + 2 floors	≤ 5 feet	0.90	
			10 feet	1.00	
			15 feet	1.10	
			20 feet	Not permitted	
3	Wall height adjustment	Any story	8 feet	0.90	
			9 feet	0.95	
			10 feet	1.00	
			11 feet	1.05	
			12 feet	1.10	
4	Number of braced wall lines (per plan)	Any story	2	1.00	
			3	1.30	
			4	1.45	

	direction) ^c		≥ 5	1.60	
5	Additional 800-pound hold-down device	Top story only	Fastened to the end studs of each braced wall panel and to the foundation or framing below	0.80	DWB, WSP, SFB, PBS, PCP, HPS
6	Interior gypsum board finish (or equivalent)	Any story	Omitted from inside face of braced wall panels	1.40	DWB, WSP, SFB, PBS, PCP, HPS, CS- WSP, CS-G, CS-SFB
7	Gypsum board fastening	Any story	4 inches o.c. at panel edges, including top and bottom plates, and all horizontal joints blocked	0.7	GB
8	<u>Horizontal blocking</u>	<u>Any story</u>	<u>Horizontal blocking is omitted.</u>	<u>2.0</u>	<u>WSP, CS-WSP</u>


For SI: 1 inch = 25.4 mm, 1 foot = 304.8 mm, 1 pound = 4.48 N.



a. Linear interpolation shall be permitted.

b. The total adjustment factor is the product of all applicable adjustment factors.

c. The adjustment factor is permitted to be 1.0 when determining bracing amounts for intermediate braced wall lines provided the bracing amounts on adjacent braced wall lines are based on a spacing and number that neglects the intermediate braced wall line.

**TABLE R602.10.3 (4)
SEISMIC ADJUSTMENT FACTORS TO THE REQUIRED LENGTH OF WALL BRACING**

ITEM NUMBER	ADJUSTMENT BASED ON:	STORY	CONDITION	ADJUSTMENT FACTOR ^{a, b} [Multiply length from Table R602.10.3(3) by this factor]	APPLICABLE METHODS
1	Story height (Section 301.3)	Any story	≤ 10 feet	1.0	All methods
			> 10 feet and ≤ 12 feet	1.2	
2	Braced wall line spacing, townhouses in SDC C	Any story	≤ 35 feet	1.0	
			> 35 feet and ≤ 50 feet	1.43	
3	Braced wall line spacing, in SDC D ₀ , D ₁ , D ₂ ^c	Any story	> 25 feet and ≤ 30 feet	1.2	
			> 30 feet and ≤ 35 feet	1.4	
4	Wall dead load	Any story	> 8 psf and < 15 psf	1.0	
			< 8 psf	0.85	
5	Roof/ceiling dead load for wall supporting	1-, 2- or 3-story building	≤ 15 psf	1.0	
		2- or 3-story building	> 15 psf and ≤ 25 psf	1.1	
		1-story building	> 15 psf and ≤ 25 psf	1.2	
6	Walls with stone or masonry veneer, townhouses in		1.0	All methods	

	SDC C ^{d, e}		1.5		
			1.5		
7	Walls with stone or masonry veneer, detached one- and two-family dwellings in SDC D ₀ – D ₂ ^{d, f}	Any story	See Table R602.10.6.5	BV-WSP	
8	Interior gypsum board finish (or equivalent)	Any story	Omitted from inside face of braced wall panels	1.5	DWB, WSP, SFB, PBS, PCP, HPS, CS-WSP, CS-G, CS-SFB
<u>9</u>	<u>Horizontal blocking</u>	<u>Any story</u>	<u>Horizontal blocking is omitted.</u>	<u>2.0</u>	<u>WSP, CS-WSP</u>

For SI: 1 foot = 304.8 mm, 1 pound per square foot = 0.0479 kPa.

- a. Linear interpolation shall be permitted.
- b. The total length of bracing required for a given wall line is the product of all applicable adjustment factors.
- c. The length-to-width ratio for the floor/roof *diaphragm* shall not exceed 3:1. The top plate lap splice nailing shall be in accordance with Table R602.3(1), Item 13.
- d. Applies to stone or masonry veneer exceeding the first story height.
- e. The adjustment factor for stone or masonry veneer shall be applied to all exterior *braced wall lines* and all *braced wall lines* on the interior of the building, backing or perpendicular to and laterally supported veneered walls.
- f. See Section R602.10.6.5 for requirements where stone or masonry veneer does not exceed the first-story height.

R602.10.40 R602.10.4.4 Panel joints. Vertical joints of panel sheathing shall occur over, and be fastened to, common studs. Horizontal joints of panel sheathing in *braced wall panels* shall occur over, and be fastened to, common blocking of a minimum 1 1/2 inch (38 mm) thickness.

Exceptions:

1. ~~Vertical joints of panel sheathing shall be permitted to occur over double studs, where adjoining panel edges are attached to separate studs with the required panel edge fastening schedule, and the adjacent studs are attached together with two rows of 10d box nails [3 inches by 0.128 inch (76.2 mm by 3.25 mm)] at 10 inches o.c. (254 mm). For methods WSP and CS-WSP, blocking of horizontal joints is permitted to be omitted when adjustment factor number 8 of Table R602.10.3(2) or number 9 of Table R602.3(4) is applied.~~

2. ~~Blocking at horizontal joints shall not be required in wall segments that are not counted as braced wall panels.~~
3. ~~Where the bracing length provided is not less than twice the minimum length required by Tables R602.10.3(1) and R602.10.3(3), blocking at horizontal joints shall not be required in braced wall panels constructed using Methods WSP, SFB, GB, PBS or HPS.~~
4. ~~Where Method GB panels are installed horizontally, blocking of horizontal joints is not required.~~
5. For methods WSP and CS-WSP, blocking of horizontal joints is permitted to be omitted when adjustment factor number 8 of Table R602.10.3(2) or number 9 of Table R602.3(4) is applied.
6. Vertical joints of panel sheathing shall be permitted to occur over double studs, where adjoining panel edges are attached to separate studs with the required panel edge fastening schedule, and the adjacent studs are attached together with two rows of 10d box nails [3 inches by 0.128 inch (76.2 mm by 3.25 mm)] at 10 inches o.c. (254 mm).
7. Blocking at horizontal joints shall not be required in wall segments that are not counted as braced wall panels.
8. Where Method GB panels are installed horizontally, blocking of horizontal joints is not required.

Reason:

WHAT: This code change proposal is intended to move requirements for construction of braced wall panels in R602.10.10 and move it to the section on construction methods for braced wall panels in R602.10.4, and move an existing bracing amount correction from R602.10.10 (exception #3) into the Adjustment Factor Tables, R602.10.3(2) for wind and R602.10.3(4) for seismic.

WHY: Several members of the past ICC Ad Hoc Wall Bracing committee discussed this issue and agreed that the existing language is confusing and that it made sense to move this this correction factor into the tables with all of the other adjustment factors.

Currently this adjustment factor for horizontal blocking is virtually lost because it is near the end of the wall bracing section. While discussing the issue, it became apparent to the members that there were some wrong materials listed in R602.10.10. Revisions of the panels that are permitted to omit horizontal blocking is based on the shear wall provisions of the AWC Special Design Provisions for Wind and Seismic (2015 SDPWS). That document is the code-referenced standard for design of shearwalls, and it permits unblocked WSP shearwalls only if the capacity is reduced by half. For SFB and PB shear walls, all panel edges are required to be blocked. Data was submitted to the ICC Ad Hoc Wall Bracing Committee regarding no reduction for horizontal gypsum board. Since SFB, vertical GB and HPS are not permitted to be unblocked, they were eliminated from the table.

Bibliography: Special Design Provisions for Wood Construction (ANSI/AWC SDPWS-2015), American Wood Council, 2015 www.awc.org

Cost Impact: Will not increase the cost of construction

This code should not increase the cost of construction.

Under the 2015 IRC, it is possible that if the bracing amount is doubled, then blocking could be omitted for SFB, vertical GB, or HPS. This option will not be available if this proposal is approved. But the cost of the blocking is far less than the cost of doubling the bracing amount so there should be no cost increase.

Report of Committee Action Hearings

Committee Action:**Approved as Modified****Modify as follows:**

R602.10.4.4 Panel joints. Vertical joints of panel sheathing shall occur over, and be fastened to, common studs. Horizontal joints of panel sheathing in *braced wall panels* shall occur over, and be fastened to, common blocking of a minimum 1¹/₂ inch (38 mm) thickness.

Exceptions:

1. For methods WSP and CS-WSP, blocking of horizontal joints is permitted to be omitted when adjustment factor number 8 of Table R602.10.3(2) or number 9 of Table ~~R602.3(4)~~ R602.10.3(4) is applied.
2. Vertical joints of panel sheathing shall be permitted to occur over double studs, where adjoining panel edges are attached to separate studs with the required panel edge fastening schedule, and the adjacent studs are attached together with two rows of 10d box nails [3 inches by 0.128 inch (76.2 mm by 3.25 mm)] at 10 inches o.c. (254 mm).
3. Blocking at horizontal joints shall not be required in wall segments that are not counted as *braced wall panels*.
4. Where Method GB panels are installed horizontally, blocking of horizontal joints is not required.

Committee Reason: This changes moves the adjustment factor for the absence of horizontal blocking into the wind and seismic adjustment factor table where it belongs. The modification corrects the reference table number in exception 1.

Assembly Action

None

Final Action Results

RB230-16

AM

[←BACK](#)

Code Change No: RB231-16

Original Proposal

Section: R602, R602.10.3

Proponent: Charles Bajnai, representing Chesterfield County, VA and Virginia Building Code Officials Association (VBCOA) (bajnaic@chesterfield.gov)

Revise as follows:

TABLE R602.10.3(2)
WIND ADJUSTMENT FACTORS TO THE REQUIRED LENGTH OF WALL BRACING

ITEM NUMBER	ADJUSTMENT BASED ON	STORY/SUPPORTING	CONDITION	ADJUSTMENT FACTOR ^a ^b [multiply length from Table R602.10.3(1) by this factor]	APPLICABLE METHODS
1	Exposure category ^d	One-story structure	B	1.00	All methods
			C	1.20	
			D	1.50	
		Two-story structure	B	1.00	
			C	1.30	
			D	1.60	
		Three-story structure	B	1.00	
			C	1.40	
			D	1.70	
2	Roof eave-to-ridge height	Roof only	≤ 5 feet	0.70	
			10 feet	1.00	
			15 feet	1.30	
			20 feet	1.60	
		Roof + 1 floor	≤ 5 feet	0.85	
			10 feet	1.00	
			15 feet	1.15	
			20 feet	1.30	
		Roof + 2 floors	≤ 5 feet	0.90	
			10 feet	1.00	

			15 feet	1.10	
			20 feet	Not permitted	
3	Wall height adjustment	Any story	8 feet	0.90	
			9 feet	0.95	
			10 feet	1.00	
			11 feet	1.05	
			12 feet	1.10	
4	Number of braced wall lines (per plan direction) ^c	Any story	2	1.00	
			3	1.30	
			4	1.45	
			≥ 5	1.60	
5	Additional 800-pound hold-down device	Top story only	Fastened to the end studs of each braced wall panel and to the foundation or framing below	0.80	DWB, WSP, SFB, PBS, PCP, HPS
6	Interior gypsum board finish (or equivalent)	Any story	Omitted from inside face of braced wall panels	1.40	DWB, WSP, SFB, PBS, PCP, HPS, CS- WSP, CS-G, CS-SFB
7	Gypsum board fastening	Any story	4 inches o.c. at panel edges, including top and bottom plates, and all horizontal joints blocked	0.7	GB

For SI: 1 inch = 25.4 mm, 1 foot = 304.8 mm, 1 pound = 4.48 N.







- a. Linear interpolation shall be permitted.
- b. The total adjustment factor is the product of all applicable adjustment factors.
- c. The adjustment factor is permitted to be 1.0 when determining bracing amounts for intermediate braced wall lines provided the bracing amounts on adjacent braced wall lines are based on a spacing and number that neglects the intermediate braced wall line.
- d. The same adjustment factor shall be applied to all braced wall lines on all floors of the structure, based on worst case exposure category.

Reason: ICC staff requested an unofficial interpretation from the past ICC Ad Hoc Wall Bracing Committee regarding how the adjustment factor for Exposure Category applied. The new footnote has been vetted by several of the past members and is being submitted to clarify the intent.

Concurrently, icons have been added to further clarify the intention of both the exposure category and the eave-to-ridge height.

TABLE R602.10.3(2)

WIND ADJUSTMENT FACTORS TO THE REQUIRED LENGTH OF WALL BRACING

ITEM NUMBER	ADJUSTMENT BASED ON	STORY/SUPPORTING	CONDITION	ADJUSTMENT FACTOR	APPLICABLE METHOD
1	Exposure category ^d	One story structure 	B	1.00	
			C	1.20	
			D	1.50	
		Two-story structure 	B	1.00	
			C	1.30	
			D	1.60	
		Three-story structure 	B	1.00	
			C	1.40	
			D	1.70	
2	Roof eave-to-ridge height	Roof only 	≤ 5 feet	.70	
			10 feet	1.00	
			15 feet	1.30	
			20 feet	1.60	
		Roof + 1 floor 	≤ 5 feet	.85	
			10 feet	1.00	
			15 feet	1.15	
			20 feet	1.60	
		Roof + 2 floors 	≤ 5 feet	.90	
			10 feet	1.00	
			15 feet	1.10	
			20 feet	Not permitted	

Report of Committee Action Hearings

Committee Action:

Approved as Submitted

Committee Reason: The added footnote clarifies how to apply the adjustment factor for Exposure Category when there are multiple categories on the site.

Assembly Action:

None

Final Action Results

RB231-16

AS

[←BACK](#)

Code Change No: **RB233-16**




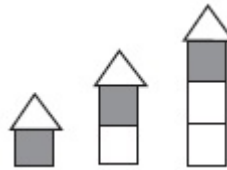
Original Proposal



Section: R602.10.3

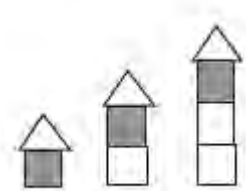
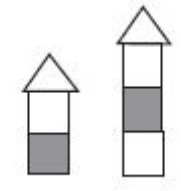


Proponent: Edward Keith, representing APA- The Engineered Wood Association
(ed.keith@apawood.org)

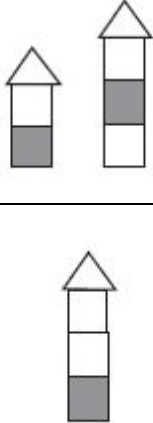
Revise as follows:

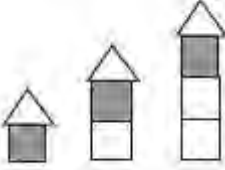
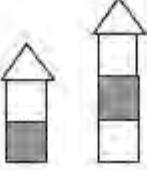

TABLE R602.10.3 (1)
BRACING REQUIREMENTS BASED ON WIND SPEED

· EXPOSURE CATEGORY B · 30-FOOT MEAN ROOF HEIGHT · 10-FOOT WALL HEIGHT · 2 BRACED WALL LINES			MINIMUM TOTAL LENGTH (FEET) OF BRACED WALL PANELS REQUIRED ALONG EACH BRACED WALL LINE ^a			
Ultimate Design Wind Speed (mph)	Story Location	Braced Wall Line Spacing ^c (feet)	Method LIB ^b	Method GB	Methods DWB, WSP, SFB, PBS, PCP, HPS, BV-WSP, ABW, PFH, PFC, CS-SFB ^e	Methods CS-WSP, CS-G, CS-PF
≤110		10	3.5	3.5	2.0	1.5
		20	6.0	6.0	3.5	3.0
		30	8.5	8.5	5.0	4.5
		40	11.5	11.5	6.5	5.5
		50	14.0	14.0	8.0	7.0
		60	16.5	16.5	9.5	8.0
		10	6.5	6.5	3.5	3.0
		20	11.5	11.5	6.5	5.5
		30	16.5	16.5	9.5	8.0
		40	21.5	21.5	12.5	10.5
		50	26.5	26.5	15.5	13.0
		60	31.5	31.5	18.0	15.5
		10	NP	9.5	5.5	4.5
		20	NP	17.0	10.0	8.5
		30	NP	24.5	14.0	12.0
		40	NP	32.0	18.5	15.5
		50	NP	39.5	22.5	19.0
		60	NP	46.5	26.5	23.0
≤ 115		10	3.5	3.5	2.0	2.0
		20	6.5	6.5	3.5	3.5
		30	9.5	9.5	5.5	4.5
		40	12.5	12.5	7.0	6.0
		50	15.0	15.0	9.0	7.5
		60	18.0	18.0	10.5	9.0

	10	7.0	7.0	4.0	3.5	
	20	12.5	12.5	7.5	6.5	
	30	18.0	18.0	10.5	9.0	
	40	23.5	23.5	13.5	11.5	
	50	29.0	29.0	16.5	14.0	
	60	34.5	34.5	20.0	17.0	
		10	NP	10.0	6.0	5.0
		20	NP	18.5	11.0	9.0
		30	NP	27.0	15.5	13.0
		40	NP	35.0	20.0	17.0
		50	NP	43.0	24.5	21.0
		60	NP	51.0	29.0	25.0

· EXPOSURE CATEGORY B · 30-FOOT MEAN ROOF HEIGHT · 10-FOOT WALL HEIGHT · 2 BRACED WALL LINES			MINIMUM TOTAL LENGTH (FEET) OF BRACED WALL PANELS REQUIRED ALONG EACH BRACED WALL LINE ^a			
Ultimate Design Wind Speed (mph)	Story Location	Braced Wall Line Spacing (feet)	Method LIB ^b	Method GB	Methods DWB, WSP, SFB, PBS, PCP, HPS, BV-WSP, ABW, PFH, PFG, CS-SFB ^c	Methods CS-WSP, CS-G, CS-PF
≤ 120		10	4.0	4.0	2.5	2.0
		20	7.0	7.0	4.0	3.5
		30	10.5	10.5	6.0	5.0
		40	13.5	13.5	8.0	6.5
		50	16.5	16.5	9.5	8.0
		60	19.5	19.5	11.5	9.5
		10	7.5	7.5	4.5	3.5
		20	14.0	14.0	8.0	7.0
		30	20.0	20.0	11.5	9.5
		40	25.5	25.5	15.0	12.5
		50	31.5	31.5	18.0	15.5
		60	37.5	37.5	21.5	18.5
		10	NP	11.0	6.5	5.5
		20	NP	20.5	11.5	10.0
		30	NP	29.0	17.0	14.5
		40	NP	38.0	22.0	18.5
		50	NP	47.0	27.0	23.0
		60	NP	55.5	32.0	27.0
≤ 130		10	4.5	4.5	2.5	2.5
		20	8.5	8.5	5.0	4.0

	30	12.0	12.0	7.0	6.0
	40	15.5	15.5	9.0	7.5
	50	19.5	19.5	11.0	9.5
	60	23.0	23.0	13.0	11.0
	10	8.5	8.5	5.0	4.5
	20	16.0	16.0	9.5	8.0
	30	23.0	23.0	13.5	11.5
	40	30.0	30.0	17.5	15.0
	50	37.0	37.0	21.5	18.0
	60	44.0	44.0	25.0	21.5
	10	NP	13.0	7.5	6.5
	20	NP	24.0	13.5	11.5
	30	NP	34.5	19.5	17.0
	40	NP	44.5	25.5	22.0
	50	NP	55.0	31.5	26.5
	60	NP	65.0	37.5	31.5

· EXPOSURE CATEGORY B · 30-FOOT MEAN ROOF HEIGHT · 10-FOOT WALL HEIGHT · 2 BRACED WALL LINES			MINIMUM TOTAL LENGTH (FEET) OF BRACED WALL PANELS REQUIRED ALONG EACH BRACED WALL LINE ^a			
Ultimate Design Wind Speed (mph)	Story Location	Braced Wall Line Spacing (feet)	Method LIB ^b	Method GB	Methods DWB, WSP, SFB, PBS, PCP, HPS, BV-WSP, ABW, PFH, PFG, CS-SFB ^c	Methods CS-WSP, CS-G, CS-PF
≤ 140		10	5.5	5.5	3.0	2.5
		20	10.0	10.0	5.5	5.0
		30	14.0	14.0	8.0	7.0
		40	18.0	18.0	10.5	9.0
		50	22.5	22.5	13.0	11.0
		60	26.5	26.5	15.0	13.0
		10	10.0	10.0	6.0	5.0
		20	18.5	18.5	11.0	9.0
		30	27.0	27.0	15.5	13.0
		40	35.0	35.0	20.0	17.0
		50	43.0	43.0	24.5	21.0
		60	51.0	51.0	29.0	25.0
		10	NP	15.0	8.5	7.5
		20	NP	27.5	16.0	13.5

		30	NP	39.5	23.0	19.5
		40	NP	51.5	29.5	25.0
		50	NP	63.5	36.5	31.0
		60	NP	75.5	43.0	36.5

For SI: 1 inch = 25.4 mm, 1 foot = 304.8 mm, 1 mile per hour = 0.447 m/s.

- a. Linear interpolation shall be permitted.
- b. Method LIB shall have gypsum board fastened to not less than one side with nails or screws in accordance with Table R602.3(1) for exterior sheathing or Table R702.3.5 for interior gypsum board. Spacing of fasteners at panel edges shall not exceed 8 inches.
- c. Where a braced wall line has three or more parallel braced wall lines on one or both sides of differing dimensions are present and the distances between adjacent braced wall lines are different, the average dimension shall be permitted to be used for braced wall line spacing.

Reason: The callout for Footnote (c) was inadvertently left off of the table. This proposal places it in the table in the appropriate location.

As Footnote (c) is currently written, it is unclear that the "differing dimensions" discussed are the distance between braced wall lines and not braced wall line lengths. In addition, for differing distances between braced wall lines to be possible, there must be at least 3 parallel braced wall lines. As such it is not possible for this to be true if the parallel braced wall line exists only on "one side". The proposed language corrects this possible point of confusion while it more clearly states the intent of the provision.

Cost Impact: Will not increase the cost of construction

This code changes has no impact on the cost of construction. It clarifies the original intent of the Code.

Report of Committee Action Hearings

Committee Action:

Approved as Submitted

Committee Reason: The committee approved this proposal based on the proponents published reason statement. Also, due to an error in the submittal process the superscript c should be shown added to the 3rd column in three places and deleted from the 6th column in three places.

Assembly Action:

None

Final Action Results

RB233-16

AS

[←BACK](#)

[←BACK](#)Code Change No: **RB234-16**

Original Proposal

Section: R602.10.3

Proponent: Edward Keith, representing APA- The Engineered Wood Association (ed.keith@apawood.org)

Revise as follow:

TABLE R602.10.3 (2)
WIND ADJUSTMENT FACTORS TO THE REQUIRED LENGTH OF WALL BRACING

ITEM NUMBER	ADJUSTMENT BASED ON	STORY/SUPPORTING	CONDITION	ADJUSTMENT FACTOR ^a ^b [multiply length from Table R602.10.3(1) by this factor]	APPLICABLE METHODS
1	Exposure category	One-story structure	B	1.00	All methods
			C	1.20	
			D	1.50	
		Two-story structure	B	1.00	
			C	1.30	
			D	1.60	
		Three-story structure	B	1.00	
			C	1.40	
			D	1.70	
2	Roof eave-to-ridge height	Roof only	≤ 5 feet	0.70	
			10 feet	1.00	
			15 feet	1.30	
			20 feet	1.60	
		Roof + 1 floor	≤ 5 feet	0.85	
			10 feet	1.00	
			15 feet	1.15	
			20 feet	1.30	
		Roof + 2 floors	≤ 5 feet	0.90	
			10 feet	1.00	
			15 feet	1.10	
			20 feet	Not permitted	
3	Wall Story height adjustment (R301.3)	Any story	8 feet	0.90	
			9 feet	0.95	
			10 feet	1.00	
			11 feet	1.05	
			12 feet 11 feet – 7 inches	1.10 1.08	
4	Number of braced wall lines (per plan)	Any story	2	1.00	

ITEM NUMBER	ADJUSTMENT BASED ON	STORY/SUPPORTING	CONDITION	ADJUSTMENT FACTOR ^a ^b [multiply length from Table R602.10.3(1) by this factor]	APPLICABLE METHODS
	direction) ^c		3	1.30	
			4	1.45	
			≥ 5	1.60	
5	Additional 800-pound hold-down device	Top story only	Fastened to the end studs of each braced wall panel and to the foundation or framing below	0.80	DWB, WSP, SFB, PBS, PCP, HPS
6	Interior gypsum board finish (or equivalent)	Any story	Omitted from inside face of braced wall panels	1.40	DWB, WSP, SFB, PBS, PCP, HPS, CS-WSP, CS-G, CS-SFB
7	Gypsum board fastening	Any story	4 inches o.c. at panel edges, including top and bottom plates, and all horizontal joints blocked	0.7	GB

For SI: 1 inch = 25.4 mm, 1 foot = 304.8 mm, 1 pound = 4.48 N.

a. Linear interpolation shall be permitted.

b. The total adjustment factor is the product of all applicable adjustment factors.

c. The adjustment factor is permitted to be 1.0 when determining bracing amounts for intermediate braced wall lines provided the bracing amounts on adjacent braced wall lines are based on a spacing and number that neglects the intermediate braced wall line.

Reason: In the 2015 edition of the IRC, changes were made to Section R301.3 that shifted the emphasis from wall height to story height. As a result, there is no limitation on wall height as long as the story height does not exceed 11'-7". As a result of this change, the terminology used in the wall bracing adjustment tables (Tables R602.10.3(2) and R602.10.3(4)) was reevaluated. In reviewing these tables, it was found that the seismic adjustment table (Table R602.10.3(4)) was already written in terms of "story height." However, the wind adjustment table (Table R602.10.3(2)) in item 3 shown above still referenced "wall height". The proposed change does three things. It first makes the adjustment based on story height to put it in line with the seismic adjustment table as well as Section R301.3. Secondly, it limits the story height to 11'-7" per Section R301.3 and the new corresponding adjustment factor was interpolated based on the existing values for the adjustment factors for 11 and 12 feet. The third proposed change is to format the "ADJUSTMENT BASED ON" cell as it is in the seismic adjustment table (Table R602.10.3(4)) to make the two adjustment tables more consistent and easier for the user.

It is important to note that in the development of the current bracing provisions, one of the basic principles that was adopted by the ICC Bracing Committee was that the unadjusted bracing provisions were good up to 10 feet and heights above that were to be adjusted accordingly. What was not consistent was whether the 10 feet was a wall height or story height. The above change makes the two adjustment tables identical in how to treat story height and makes the adjustment for a 10 ft story height equal to 1.00 for both wind and seismic. This should make the 2018 IRC consistent throughout with the intent of the provisions adopted during the 2015 cycle.

We ask the committee to accept these changes to make the bracing provisions consistent throughout the various sections of the IRC and less subject to incorrect interpretation.

Cost Impact: Will not increase the cost of construction

This code change will not increase the cost of construction as it clarifies the intent of the original code provisions.

Report of Committee Action Hearings
--

Committee Action:

Approved as Modified

Modify as follows:

**TABLE R602.10.3 (2)
WIND ADJUSTMENT FACTORS TO THE REQUIRED LENGTH OF WALL BRACING**

ITEM NUMBER	ADJUSTMENT BASED ON	STORY/SUPPORTING	CONDITION	ADJUSTMENT FACTOR ^{a, b} [multiply length from Table R602.10.3(1) by this factor]	APPLICABLE METHODS
1	Exposure category	One-story structure	B	1.00	All methods
			C	1.20	
			D	1.50	
		Two-story structure	B	1.00	
			C	1.30	
			D	1.60	
		Three-story structure	B	1.00	
			C	1.40	
			D	1.70	
2	Roof eave-to-ridge height	Roof only	≤ 5 feet	0.70	
			10 feet	1.00	
			15 feet	1.30	
			20 feet	1.60	
		Roof + 1 floor	≤ 5 feet	0.85	
			10 feet	1.00	
			15 feet	1.15	
			20 feet	1.30	
		Roof + 2 floors	≤ 5 feet	0.90	
			10 feet	1.00	
			15 feet	1.10	

			20 feet	Not permitted	
3	Story height (R301.3)	Any story	8 feet	0.90	
			9 feet	0.95	
			10 feet	1.00	
			11 feet	1.05	
			12 feet 11 feet — 7 inches	1.10 1.08	
4	Number of braced wall lines (per plan direction) ^c	Any story	2	1.00	
			3	1.30	
			4	1.45	
			≥ 5	1.60	
5	Additional 800-pound hold-down device	Top story only	Fastened to the end studs of each braced wall panel and to the foundation or framing below	0.80	DWB, WSP, SFB, PBS, PCP, HPS
6	Interior gypsum board finish (or equivalent)	Any story	Omitted from inside face of braced wall panels	1.40	DWB, WSP, SFB, PBS, PCP, HPS, CS- WSP, CS-G, CS-SFB
7	Gypsum board fastening	Any story	4 inches o.c. at panel edges, including top and bottom plates, and all horizontal joints blocked	0.7	GB

For SI: 1 inch = 25.4 mm, 1 foot = 304.8 mm, 1 pound = 4.48 N.

a. Linear interpolation shall be permitted.

b. The total adjustment factor is the product of all applicable adjustment factors.

c. The adjustment factor is permitted to be 1.0 when determining bracing amounts for intermediate braced wall lines provided the bracing amounts on adjacent braced wall lines are based on a spacing and number that neglects the intermediate braced wall line.

Committee Reason: This change provides consistency with the seismic bracing table and Section R301.3 as regards the story height. The modification reverts the story height and adjustment factor back to the original 12 feet to be consistent with prior committee action.

Assembly Action

None

Final Action Results

RB234-16

AM

[←BACK](#)

Code Change No: **RB235-16**

Original Proposal

Section(s): R602.10.3, R602.10.4.1

Proponent: Edward Keith, representing APA- The Engineered Wood Association
(ed.keith@apawood.org)

Revise as follows:

**TABLE R602.10.3 (3)
BRACING REQUIREMENTS BASED ON SEISMIC DESIGN CATEGORY**

· SOIL CLASS D ^d · WALL HEIGHT = 10 FEET · 10 PSF FLOOR DEAD LOAD · 15 PSF ROOF/CEILING DEAD LOAD · BRACED WALL LINE SPACING ≤ 25 FEET			MINIMUM TOTAL LENGTH (FEET) OF BRACED WALL PANELS REQUIRED ALONG EACH BRACED WALL LINE ^{a,f}				
Seismic Design Category	Story Location	Braced Wall Line Length (feet) ^c	Method LIB ^d	Method GB	Methods DWB, SFB, PBS, PCP, HPS, CS-SFB ^e	Method WSP	Methods CS-WSP, CS-G, CS-PF
C (townhouses only)		10	2.5	2.5	2.5	1.6	1.4
		20	5.0	5.0	5.0	3.2	2.7
		30	7.5	7.5	7.5	4.8	4.1
		40	10.0	10.0	10.0	6.4	5.4
		50	12.5	12.5	12.5	8.0	6.8
		10	NP	4.5	4.5	3.0	2.6
		20	NP	9.0	9.0	6.0	5.1
		30	NP	13.5	13.5	9.0	7.7
		40	NP	18.0	18.0	12.0	10.2
		50	NP	22.5	22.5	15.0	12.8
		10	NP	6.0	6.0	4.5	3.8
		20	NP	12.0	12.0	9.0	7.7
		30	NP	18.0	18.0	13.5	11.5
		40	NP	24.0	24.0	18.0	15.3
		50	NP	30.0	30.0	22.5	19.1
D ₀		10	NP	2.8	2.8	1.8	1.6
		20	NP	5.5	5.5	3.6	3.1
		30	NP	8.3	8.3	5.4	4.6
		40	NP	11.0	11.0	7.2	6.1
		50	NP	13.8	13.8	9.0	7.7
		10	NP	5.3	5.3	3.8	3.2
		20	NP	10.5	10.5	7.5	6.4
		30	NP	15.8	15.8	11.3	9.6
		40	NP	21.0	21.0	15.0	12.8
		50	NP	26.3	26.3	18.8	16.0

		10	NP	7.3	7.3	5.3	4.5
		20	NP	14.5	14.5	10.5	9.0
		30	NP	21.8	21.8	15.8	13.4
		40	NP	29.0	29.0	21.0	17.9
		50	NP	36.3	36.3	26.3	22.3

For SI: 1 inch = 25.4 mm, 1 foot = 304.8 mm, 1 pound per square foot = 0.0479 kPa.

a. Linear interpolation shall be permitted.

b. Wall bracing lengths are based on a soil site class "D." Interpolation of bracing length between the S_{ds} values associated with the seismic design categories shall be permitted when a site-specific S_{ds} value is determined in accordance with Section 1613.3 of the *International Building Code*.

c. Where the braced wall line length is greater than 50 feet, braced wall lines shall be permitted to be divided into shorter segments having lengths of 50 feet or less, and the amount of bracing within each segment shall be in accordance with this table.

d. Method LIB shall have gypsum board fastened to not less than one side with nails or screws in accordance with Table R602.3(1) for exterior sheathing or Table R702.3.5 for interior gypsum board. Spacing of fasteners at panel edges shall not exceed 8 inches.

e. Method CS-SFB does not apply in Seismic Design Categories D_0 , D_1 and D_2 .

f. Methods ABW, PFH, and PFG may be used in conjunction with any bracing method permitted above and shall contribute to the amount of bracing assigned to that bracing method. When used alone in a braced wall line without any other bracing method, they shall be assigned the braced wall line lengths provided for Method WSP.

Reason: As the bracing methods added to the column heading and the proposed footnote are missing in the current Table R602.10.3(3), it could be construed that these methods are not permitted for resisting seismic forces. This is not the case, nor the intent of the existing table.

As Method CS-PF is permitted only in walls that are continuously sheathed, it is added to the right-hand most column where the other continuously sheathed methods are found.

Footnote (f) is proposed to add the remaining missing methods to the table. Methods ABW, PFH, and PFG are narrow wall bracing methods and, as described in the text of the IRC, are permitted to be used with any bracing method. They contribute bracing to the required bracing length for the primary bracing method in the braced wall line where they are used. In addition, all three of the methods addressed in the footnote were originally evaluated using Method WSP as the standard of comparison. Thus, when used by themselves in a braced wall line (For example, a garage section with a PFH on both sides of the garage door and no other bracing in the wall line.), the required bracing length is determined from the Method WSP column in Table R602.10.3(3).

Cost Impact: Will not increase the cost of construction

This code change will not increase the cost of construction. It clarifies the original intent of the code and is likely to save money in the long run as it makes misinterpreting the existing code less likely.

Report of Committee Action Hearings

Committee Action:

Approved as Submitted

Committee Reason: The committee felt this change added important bracing methods into the table and expands the available options.

Assembly Action:

None

Public Comments

Public Comment 2:

Randy Shackelford, representing Simpson Strong-Tie (rshackelford@strongtie.com) requests Approve as Modified by this Public Comment.

Modify as follows:

**TABLE R602.10.3 (3)
BRACING REQUIREMENTS BASED ON SEISMIC DESIGN CATEGORY**

SOIL CLASS D ^b · WALL HEIGHT = 10 FEET · 10 PSF FLOOR DEAD LOAD · 15 PSF ROOF/CEILING DEAD LOAD · BRACED WALL LINE SPACING ≤ 25 FEET			MINIMUM TOTAL LENGTH (FEET) OF BRACED WALL PANELS REQUIRED ALONG EACH BRACED WALL LINE ^{a,f}					
Seismic Design Category	Story Location	Braced Wall Line Length (feet) ^c	Method LIB ^d	Method GB	Methods DWB, SFB, PBS, PCP, HPS, CS-SFB ^e	Methods WSP, ABW, PFH, and PFG ^e	Methods CS-WSP, CS-G, CS-PF	
C (townhouses only)		10	2.5	2.5	2.5	1.6	1.4	
		20	5.0	5.0	5.0	3.2	2.7	
		30	7.5	7.5	7.5	4.8	4.1	
		40	10.0	10.0	10.0	6.4	5.4	
		50	12.5	12.5	12.5	8.0	6.8	
		10	NP	4.5	4.5	3.0	2.6	
		20	NP	9.0	9.0	6.0	5.1	
		30	NP	13.5	13.5	9.0	7.7	
		40	NP	18.0	18.0	12.0	10.2	
		50	NP	22.5	22.5	15.0	12.8	
		10	NP	6.0	6.0	4.5	3.8	
		20	NP	12.0	12.0	9.0	7.7	
		30	NP	18.0	18.0	13.5	11.5	
		40	NP	24.0	24.0	18.0	15.3	
		50	NP	30.0	30.0	22.5	19.1	
	D ₀		10	NP	2.8	2.8	1.8	1.6
			20	NP	5.5	5.5	3.6	3.1
			30	NP	8.3	8.3	5.4	4.6
			40	NP	11.0	11.0	7.2	6.1
			50	NP	13.8	13.8	9.0	7.7
		10	NP	5.3	5.3	3.8	3.2	
		20	NP	10.5	10.5	7.5	6.4	
		30	NP	15.8	15.8	11.3	9.6	
		40	NP	21.0	21.0	15.0	12.8	
		50	NP	26.3	26.3	18.8	16.0	
		10	NP	7.3	7.3	5.3	4.5	
		20	NP	14.5	14.5	10.5	9.0	
		30	NP	21.8	21.8	15.8	13.4	
		40	NP	29.0	29.0	21.0	17.9	
		50	NP	36.3	36.3	26.3	22.3	

For SI: 1 inch = 25.4 mm, 1 foot = 304.8 mm, 1 pound per square foot = 0.0479 kPa.

a. Linear interpolation shall be permitted.

b. Wall bracing lengths are based on a soil site class "D." Interpolation of bracing length between the S_{ds} values associated with the seismic design categories shall be permitted when a site-specific S_{ds} value is determined in accordance with Section 1613.3 of the *International Building Code*.

- c. Where the braced wall line length is greater than 50 feet, braced wall lines shall be permitted to be divided into shorter segments having lengths of 50 feet or less, and the amount of bracing within each segment shall be in accordance with this table.
- d. Method LIB shall have gypsum board fastened to not less than one side with nails or screws in accordance with Table R602.3(1) for exterior sheathing or Table R702.3.5 for interior gypsum board. Spacing of fasteners at panel edges shall not exceed 8 inches.
- e. ~~Method Methods~~ PFG and CS-SFB ~~does do~~ not apply in Seismic Design Categories D₀, D₁ and D₂.
- f. ~~Methods ABW, PFH, and PFG may be used in conjunction with any~~ When more than one bracing method permitted above and shall contribute to the amount of bracing assigned to that bracing method. ~~When is used alone in a braced wall line without any other bracing method, they~~ mixing methods shall be assigned the braced wall line lengths provided for Method WSP in accordance with Section R602.10.4.1.

R602.10.4.1 Mixing methods. Mixing of bracing methods shall be permitted as follows:

1. Mixing intermittent bracing and continuous sheathing methods from story to story shall be permitted.
2. Mixing intermittent bracing methods from *braced wall line* to *braced wall line* within a story shall be permitted. In regions within Seismic Design Categories A, B and C where the ultimate design wind speed is less than or equal to 130 mph (58m/s), mixing of intermittent bracing and continuous sheathing methods from braced wall line to braced wall line within a story shall be permitted.
3. Mixing intermittent bracing methods along a *braced wall line* shall be permitted in Seismic Design Categories A and B, and detached dwellings in Seismic Design Category C, provided the length of required bracing is determined in accordance with Table R602.10.3(1) or R602.10.3(3) is using the highest value of all intermittent bracing methods used.
4. Mixing of continuous sheathing methods CS-WSP, CS-G and CS-PF along a braced wall line shall be permitted. Intermittent methods ABW, PFH and PFG shall be permitted to be used along a *braced wall line* with continuous sheathed methods, provided the length of required bracing for that braced wall line is determined in accordance with Table R602.10.3(1) or R602.10.3(3) using the highest value of the bracing methods used.
5. In Seismic Design Categories A and B, and for detached one- and two-family dwellings in Seismic Design Category C, mixing of intermittent bracing methods along the interior portion of a *braced wall line* with continuous sheathing methods CS-WSP, CS-G and CS-PF along the exterior portion of the same braced wall line shall be permitted. The length of required bracing shall be the highest value of all intermittent bracing methods used in accordance with Table R602.10.3(1) or R602.10.3(3) as adjusted by Tables R602.10.3(2) and R602.10.3(4), respectively. The requirements of Section R602.10.7 shall apply to each end of the continuously sheathed portion of the braced wall line.

Commenter's Reason: We think that it shows favoritism toward certain bracing methods when only one method is added to the bracing length table, and not all applicable bracing methods.

So we are proposing to also add methods ABW, PFH, and PFG to the WSP column heading, since these are considered intermittent bracing methods and their length of bracing would be the same as a WSP panel, since that was the basis for the testing that originally evaluated these methods. Footnote e is revised to include Method PFG because PFG is only permitted in Seismic Design Categories A, B, and C per Section R602.10.6.3. We further revise the proposed Footnote f to point out to the code user that the methods can be combined as long as the requirements of Section R602.10.4.1 are met. Pointing to the general requirements on combining all methods seems better than only showing what is permitted for three methods.

In writing this public comment, we did notice one area of Section R602.10.4.1 which could use improving. That is the case where intermittent ABW, PFH, or PFG methods are mixed with continuous methods (CS-WSP, CS-G, and CS-PF). The issue is that the intermittent ABW, PFH, and PFG methods have their length of bracing based on the intermittent WSP method. The continuous methods require a shorter length of bracing because their basis is assumed to be stronger than the WSP method. If the intermittent narrow methods are combined with the stronger continuous methods and the bracing lengths are based on the continuous method, there will be an insufficient amount of bracing. So a method is proposed that is exactly the same as used in paragraphs #3 above and #5 below this one, where the bracing amount has to be based on the weaker method. This is intended to be exactly the same wording as we propose on our public comment to RB232, but is repeated here in case that proposal is not accepted.

We think this makes an improvement to the code by listing all the applicable bracing methods in the column heading for the seismic bracing length table, giving the user guidance on when all the methods can be combined, and adding the correct method for determining the length of bracing when certain methods are combined.

Final Action Results

RB235-16

AMPC2

[←BACK](#)

Code Change No: RB237-16



Original Proposal


Section: R602.10.3

Proponent: Edward Keith, representing APA- The Engineered Wood Association (ed.keith@apawood.org)

Revise as follows:

TABLE R602.10.3 (4)
SEISMIC ADJUSTMENT FACTORS TO THE REQUIRED LENGTH OF WALL BRACING

ITEM NUMBER	ADJUSTMENT BASED ON:	STORY	CONDITION	ADJUSTMENT FACTOR ^{a, b} [Multiply length from Table R602.10.3(3) by this factor]	APPLICABLE METHODS
1	Story height (Section 301.3)	Any story	≤ 10 feet	1.0	All methods
			> 10 feet and ≤ 12 feet	1.2	
2	Braced wall line spacing, townhouses in SDC C	Any story	≤ 35 feet	1.0	
			> 35 feet and ≤ 50 feet	1.43	
3	Braced wall line spacing, in SDC D ₀ , D ₁ , D ₂ ^c	Any story	> 25 feet and ≤ 30 feet	1.2	
			> 30 feet and ≤ 35 feet	1.4	
4	Wall dead load	Any story	> 8 psf and < 15 psf	1.0	
			< 8 psf	0.85	
5	Roof/ceiling dead load for wall supporting	1-, 2- or 3-story building	≤ 15 psf	1.0	
		2- or 3-story building	> 15 psf and ≤ 25 psf	1.1	
		1-story building or top story	> 15 psf and ≤ 25 psf	1.2	
6	Walls with stone or masonry veneer, townhouses in SDC C ^{d, e}		1.0		
			1.5		

			1.5		
7	Walls with stone or masonry veneer, detached one- and two-family dwellings in SDC D ₀ – D ₂ ^{d,f}	Any story	See Table R602.10.6.5		BV-WSP
8	Interior gypsum board finish (or equivalent)	Any story	Omitted from inside face of braced wall panels	1.5	DWB, WSP, SFB, PBS, PCP, HPS, CS-WSP, CS-G, CS-SFB

For SI: 1 foot = 304.8 mm, 1 pound per square foot = 0.0479 kPa.

- Linear interpolation shall be permitted.
- The total length of bracing required for a given wall line is the product of all applicable adjustment factors.
- The length-to-width ratio for the floor/roof *diaphragm* shall not exceed 3:1. The top plate lap splice nailing shall be in accordance with Table R602.3(1), Item 13.
- Applies to stone or masonry veneer exceeding the first story height.
- The adjustment factor for stone or masonry veneer shall be applied to all exterior *braced wall lines* and all *braced wall lines* on the interior of the building, backing or perpendicular to and laterally supported veneered walls.
- See Section R602.10.6.5 for requirements where stone or masonry veneer does not exceed the first-story height.

Reason: The existing language was added to the IRC in previous cycles to clarify the intent of the code as to the adjustments required for various roof load and story level conditions. The existing language was changed to better correlate with the column heading, "STORY". In doing so, an important condition was inadvertently left out. This combination was the adjustment for the top story of a multiple story building for the condition "> 15 psf and < 25 psf". For this case, as in the 2012 IRC, the appropriate adjustment factor is the same as it is for a single story building. This proposal will correct the error resulting from the wording change at last cycle and bring the provisions back in line with the 2012 and earlier IRCs.

Cost Impact: Will not increase the cost of construction

This change will not increase the cost of construction as the current provisions are in error for the 2015 IRC for those jurisdictions that use the 2012 and earlier IRCs where the adjustment factor was specified correctly.

Report of Committee Action Hearings
--

Committee Action:

Approved as Submitted

Committee Reason: The committee approved this proposal based on the proponents published reason statement. This corrects previous code cycle language that was left out of the 2015 IRC.

Assembly Action:

None

Final Action Results

RB237-16

AS

[←BACK](#)

[←BACK](#)

Code Change No: RB239-16

Original Proposal

Section: R602.10.3, R602.10.6.5

Proponent: Kelly Cobeen, Wiss Janney Elstner Associates, Inc., representing Federal Emergency Management Agency and National Institute of Building Sciences Building Seismic Safety Council Code Resource Support Committee (KCobeen@wje.com)

Revise as follows:

TABLE R602.10.3 (4)
SEISMIC ADJUSTMENT FACTORS TO THE REQUIRED LENGTH OF WALL BRACING

ITEM NUMBER	ADJUSTMENT BASED ON:	STORY	CONDITION	ADJUSTMENT FACTOR ^{a, b} [Multiply length from Table R602.10.3(3) by this factor]	APPLICABLE METHODS
1	Story height (Section 301.3)	Any story	≤ 10 feet	1.0	All methods
			> 10 feet and ≤ 12 feet	1.2	
2	Braced wall line spacing, townhouses in SDC C	Any story	≤ 35 feet	1.0	
			> 35 feet and ≤ 50 feet	1.43	
3	Braced wall line spacing, in SDC D ₀ , D ₁ , D ₂ ^c	Any story	> 25 feet and ≤ 30 feet	1.2	
			> 30 feet and ≤ 35 feet	1.4	
4	Wall dead load	Any story	> 8 psf and < 15 psf	1.0	
			< 8 psf	0.85	
5	Roof/ceiling dead load for wall supporting	1-, 2- or 3-story building	≤ 15 psf	1.0	
		2- or 3-story building	> 15 psf and ≤ 25 psf	1.1	
		1-story building	> 15 psf and ≤ 25 psf	1.2	
6	Walls with stone or masonry veneer, townhouses in SDC C ^{d, e}		1.0	All methods	
			1.5		
			1.5		
7	Walls with stone or masonry veneer, detached one- and two-family dwellings	Any story	See Table R602.10.6.5	BV-WSP	

	in SDC D ₀ – D ₂ ^{d, f}				
8	Walls with stone or masonry veneer, detached one- and two-family dwellings in SDC D ₀ – D ₂ ^{d, f}	First and second story of two-story dwelling	See R602.10.6.5	1.2	WSP, CS-WSP
8g	Interior gypsum board finish (or equivalent)	Any story	Omitted from inside face of braced wall panels	1.5	DWB, WSP, SFB, PBS, PCP, HPS, CS-WSP, CS-G, CS-SFB

For SI: 1 foot = 304.8 mm, 1 pound per square foot = 0.0479 kPa.

- Linear interpolation shall be permitted.
- The total length of bracing required for a given wall line is the product of all applicable adjustment factors.
- The length-to-width ratio for the floor/roof *diaphragm* shall not exceed 3:1. The top plate lap splice nailing shall be in accordance with Table R602.3(1), Item 13.
- Applies to stone or masonry veneer exceeding the first story height.
- The adjustment factor for stone or masonry veneer shall be applied to all exterior *braced wall lines* and all *braced wall lines* on the interior of the building, backing or perpendicular to and laterally supported veneered walls.
- See Section R602.10.6.5 for requirements where stone or masonry veneer does not exceed the first-story height.

Revise as follows:

R602.10.6.5 Wall bracing for dwellings with stone and masonry veneer in Seismic Design

Categories D₀, D₁ and D₂. Where stone and masonry veneer are installed in accordance with Section R703.8, wall bracing on exterior *braced wall lines* and *braced wall lines* on the interior of the building, backing or perpendicular to and laterally supporting veneered walls shall comply with this section.

Where dwellings in Seismic Design Categories D₀, D₁ and D₂ have stone or masonry veneer installed in accordance with Section R703.8, and the veneer does not exceed the first-story height, wall bracing shall be in accordance with Section R602.10.3.

Where detached one- or two-family dwellings in Seismic Design Categories D₀, D₁ and D₂ have stone or masonry veneer installed in accordance with Section R703.7, and the veneer exceeds the first-story height, wall bracing at exterior *braced wall lines* and *braced wall lines* on the interior of the building shall be constructed using Method BV-WSP in accordance with this section and Figure R602.10.6.5. Cripple walls shall not be permitted, and required interior *braced wall lines* shall be supported on continuous foundations.

Where detached one- or two-family dwellings in Seismic Design Categories D₀, D₁ and D₂ have exterior veneer installed in accordance with Section R703.8 and are braced in accordance with methods WSP or CS-WSP, veneer shall be permitted in the second story in accordance with Items 1 or 2 below, provided the dwelling does not extend more than two stories above grade plane, the veneer does not exceed 5 inches in thickness, the height of veneer on gable-end walls does not extend more than eight feet above the bearing wall top plate elevation, and the total length of braced wall panel specified by Table R602.10.3 is multiplied by 1.2 for each first and second story braced wall line.

- The total area of the veneer on the second-story exterior walls shall be permitted to extend up to 25 percent of the occupied second floor area, or
- The veneer on the second-story exterior walls shall be permitted to cover one side of the dwelling, including walls on bay windows and similar appurtenances within the one dwelling side.

Townhouses in Seismic Design Categories D₀, D₁ and D₂ with stone or masonry veneer exceeding the first-story height shall be designed in accordance with accepted engineering practice.

Reason: In some regions with high seismicity, home builders are commonly installing a limited area of veneer on the second story of two-story dwellings, particularly on the street side of the dwelling. In Seismic Design Categories D₀, D₁ and D₂ when any veneer

extends above the first story, the 2015 IRC requires the use of BV-WSP bracing, with a complete set of tie-downs in exterior walls over all stories. This current IRC requirement can be cost-prohibitive. The intent of this code change is to provide another alternative in which a moderate amount of second story veneer is permitted with a moderate increase in the bracing wall length, while maintaining a similar level of seismic safety.

Cost Impact: Will not increase the cost of construction

This proposal will notably reduce the cost of construction by removing the cost of most or all tie-down hardware. For one example dwelling the cost savings is estimated to be approximately \$3,500.00, including \$3,000 for materials and labor to install tie-downs, and \$500.00 in design costs.

Report of Committee Action Hearings
--

Committee Action:

Approved as Submitted

Committee Reason: The committee felt this is a good change as it adds alternatives that allows a minimal amount of masonry veneer to the second story in SDC D₀, D₁ and D₂.

Assembly Action:

None

Final Action Results

RB239-16

AS

[←BACK](#)

Code Change No: RB240-16

Original Proposal

Section: R602.10.4**Proponent:** Matthew Hunter, representing American Wood Council (mhunter@awc.org)**Revise as follows:**

**TABLE R602.10.4
BRACING METHODS**

METHODS, MATERIAL		MINIMUM THICKNESS	FIGURE	CONNECTION CRITERIA ^a	
				Fasteners	Spacing
Intermittent Bracing Method	LIB Let-in-bracing	1 × 4 wood or approved metal straps at 45° to 60° angles for maximum 16" stud spacing		Wood: 2-8d common nails or 3-8d (2 ¹ / ₂ " long × 0.113" dia.) nails	Wood: per stud and top and bottom plates
				Metal strap: per manufacturer	Metal: per manufacturer
	DWB Diagonal wood boards	³ / ₄ " (1" nominal) for maximum 24" stud spacing		2-8d (2 ¹ / ₂ " long × 0.113" dia.) nails or 2 - 1 ³ / ₄ " long staples	Per stud
	WSP Wood structural panel (See Section R604)	³ / ₈ "		Exterior sheathing per Table R602.3(3)	6" edges 12" field
				Interior sheathing per Table R602.3(1) or R602.3(2)	Varies by fastener
	BV-WSP⁶ Wood structural panels with stone or masonry veneer (See Section R602.10.6.5)	⁷ / ₁₆ "	See Figure R602.10.6.5	8d common (2 ¹ / ₂ " × 0.131) nails	4" at panel edges 12" at intermediate supports 4" at braced wall panel end posts
	SFB Structural fiberboard sheathing	¹ / ₂ " or ²⁵ / ₃₂ " for maximum 16" stud spacing		1 ¹ / ₂ " long × 0.12" dia. (for ¹ / ₂ " thick sheathing) or 1 ³ / ₄ " long × 0.12" dia. (for ²⁵ / ₃₂ " thick sheathing) galvanized roofing nails or 8d common (2 1/2" long × 0.131" dia.) nails	3" edges 6" field
	GB Gypsum board	¹ / ₂ "		Nails or screws per Table R602.3(1) for exterior locations	For all braced wall panel locations: 7" edges (including top and bottom plates) 7" field
Nails or screws per Table R702.3.5 for interior locations					
PBS Particleboard sheathing (See Section R605)	³ / ₈ " or ¹ / ₂ " for maximum 16" stud spacing		For ³ / ₈ ", 6d common (2" long × 0.113" dia.) nails For ¹ / ₂ ", 8d common (2 ¹ / ₂ " long × 0.131" dia.) nails	3" edges 6" field	

	PCP Portland cement plaster	See Section R703.6 for maximum 16" stud spacing		1 1/2" long, 11 gage, 7/16" dia. head nails or 7/8" long, 16 gage staples	6" o.c. on all framing members
	HPS Hardboard panel siding	7/16" for maximum 16"stud spacing		0.092" dia., 0.225" dia. head nails with length to accommodate 1 1/2" penetration into studs	4" edges 8" field
	ABW Alternate braced wall	3/8"		See Section R602.10.6.1	See Section R602.10.6.1

METHODS, MATERIAL		MINIMUM THICKNESS	FIGURE	CONNECTION CRITERIA ^a	
				Fasteners	Spacing
Intermittent Bracing Methods	PFH Portal frame with hold-downs	3/8"		See Section R602.10.6.2	See Section R602.10.6.2
	PFG Portal frame at garage	7/16"		See Section R602.10.6.3	See Section R602.10.6.3
Continuous Sheathing Methods	CS-WSP Continuously sheathed wood structural panel	3/8"		Exterior sheathing per Table R602.3(3) Interior sheathing per Table R602.3(1) or R602.3(2)	6" edges 12" field Varies by fastener
	CS-G^b ^c Continuously sheathed wood structural panel adjacent to garage openings	3/8"		See Method CS-WSP	See Method CS-WSP
	CS- PF Continuously sheathed portal frame	7/16"		See Section R602.10.6.4	See Section R602.10.6.4
	CS-SFB^d Continuously sheathed structural fiberboard	1 1/2" or 25/32" for maximum 16" stud spacing		1 1/2" long × 0.12" dia. (for 1/2" thick sheathing) or 1 3/4" long × 0.12" dia. (for 25/32" thick sheathing) galvanized roofing nails or 8d common (2 1/2" long × 0.131" dia.) nails	3" edges 6" field

For SI: 1 inch = 25.4 mm, 1 foot = 304.8 mm, 1 degree = 0.0175 rad, 1 pound per square foot = 47.8 N/m², 1 mile per hour = 0.447 m/s.

- Adhesive attachment of wall sheathing, including Method GB, shall not be permitted in Seismic Design Categories C, D₀, D₁ and D₂.
- Applies to panels next to garage door opening where supporting gable end wall or roof load only. Shall only be used on one wall of the garage. In Seismic Design Categories D₀, D₁ and D₂ roof covering dead load shall not exceed 3 psf.
- Garage openings adjacent to a Method CS-G panel shall be provided with a header in accordance with Table R602.7(1). A full-height clear opening shall not be permitted adjacent to a Method CS-G panel.
- Method CS-SFB does not apply in Seismic Design Categories D₀, D₁ and D₂.
- Method applies to detached one- and two-family dwellings in Seismic Design Categories D₀ through D₂ only.

Reason: 8d common nails are no longer recommended for use with structural fiberboard sheathing. Removal of 8d common nails from Table R602.3.(1) for attachment of structural fiberboard sheathing was the result of proposal S75-06/07 Part II. Removal of the 8d common nail aligns with the prescribed attachment for fiberboard sheathing per fastener schedule Table R602.3(1).

Cost Impact: Will not increase the cost of construction

Other code approved, prescriptive methods are permitted in lieu of the 8d nail size. Therefore there is no cost increase associated with this revision.

**Report of Committee Action
Hearings**

Committee Action:

Approved as Submitted

Errata: In Table R602,10.4, under column heading FIGURE, the figures are not to be deleted.

Committee Reason: The committee approved this proposal based on the proponents published reason statement.

Assembly Action:

None

Final Action Results

RB240-16

AS

[←BACK](#)

Code Change No: RB241-16

Original Proposal

Section: R602.10.5

Proponent: Edward Keith, representing APA- The Engineered Wood Association (ed.keith@apawood.org)

Revise as follow:

TABLE R602.10.5
MINIMUM LENGTH OF BRACED WALL PANELS

METHOD (See Table R602.10.4)		MINIMUM LENGTH ^a (inches)					CONTRIBUTING LENGTH (inches)
		Wall Height					
		8 feet	9 feet	10 feet	11 feet	12 feet	
DWB, WSP, SFB, PBS, PCP, HPS, BV-WSP		48	48	48	53	58	Actual ^b
GB		48	48	48	53	58	Double sided = Actual Single sided = 0.5 x Actual
LIB		55	62	69	NP	NP	Actual ^b
ABW	SDC A, B and C, ultimate design wind speed	28	32	34	38	42	48
	SDC D ₀ , D ₁ and D ₂ , ultimate design wind speed	32	32	34	NP	NP	
PFH	Supporting roof only	16	16	16	18 ^e	20 ^e	48
	Supporting one story and roof	24	24	24	27 ^e	29 ^e	48
PFG		24	27	30	33 ^d	36 ^d	1.5 x Actual ^b
CS-G		24	27	30	33	36	Actual ^b
CS-PF	SDC A, B and C	16	18	20	22 ^e	24 ^e	1.5 x Actual ^b
	SDC D ₀ , D ₁ and D ₂	16	18	20	22 ^e	24 ^e	Actual ^b
CS-WSP, CS-SFB	Adjacent clear opening height (inches)	-	-	-	-	-	-
	≤ 64	24	27	30	33	36	Actual ^b
	68	26	27	30	33	36	
	72	27	27	30	33	36	
	76	30	29	30	33	36	
	80	32	30	30	33	36	
	84	35	32	32	33	36	
88	38	35	33	33	36		

	92	43	37	35	35	36	
	96	48	44	38	36	36	
	100	—	44	40	38	38	
	104	—	49	43	40	39	
	108	—	54	46	43	44	
	112	—	—	50	45	43	
	116	—	—	55	48	45	
	120	—	—	60	52	48	
	124	—	—	—	56	51	
	128	—	—	—	61	54	
	132	—	—	—	66	58	
	136	—	—	—	—	62	
	140	—	—	—	—	66	
	144	—	—	—	—	72	
METHOD (See Table R602.10.4)		MINIMUM LENGTH ^a (inches)					CONTRIBUTING LENGTH (inches)
		Wall Height					
		8 feet	9 feet	10 feet	11 feet	12 feet	
DWB, WSP, SFB, PBC, PCP, HPS, BV-WSP		48	48	48	53	58	Actual ^b
GB		48	48	48	53	58	Double sided = Actual ^b Single sided = 0.5 x Actual ^b
LIB		55	62	69	NP	NP	Actual ^b
ABW	SDC A, B and C Wind speed < 110 mph	28	32	34	38	42	48
	SDC D ₀ , D ₁ and D ₂ Wind speed < 110 mph	32	32	34	NP	NP	
CS-G		24	27	30	33	36	Actual ^b
CS-WSP, CS-SFB	Adjacent clear opening height (inches)	-	-	-	-	-	Actual ^b
	<64	24	27	30	33	36	
	68	26	27	30	33	36	
	72	27	27	30	33	36	
	76	30	29	30	33	36	
	80	32	30	30	33	36	
	84	35	32	32	33	36	
	88	38	35	33	33	36	
	92	43	37	35	35	36	
	96	48	41	38	36	36	
	100	---	44	40	38	38	
	104	---	49	43	40	39	
	108	---	54	46	43	41	
	112	---	---	50	45	43	
116	---	---	55	48	45		
120	---	---	60	52	48		

	124	---	---	---	56	51		
	128	---	---	---	61	54		
	132	---	---	---	66	58		
	136	---	---	---	---	62		
	140	---	---	---	---	66		
	144	---	---	---	---	72		
METHOD		Wall Portal Header Height						
(See Table R602.10.4)		8 feet	9 feet	10 feet	11 feet	12 feet		
PFH	Supporting roof only	16	16	16	Footnote c	Footnote c	48	
	Supporting one story and roof	24	24	24	Footnote c	Footnote c	48	
PFG		24	27	30	Footnote d	Footnote d	1.5 x Actual ^b	
CS-PF	SDC A, B and C	16	18	20	Footnote e	Footnote e	1.5 x Actual ^b	
	SDC D ₀ , D ₁ and D ₂	16	18	20	Footnote e	Footnote e	Actual ^b	

For SI: 1 inch = 25.4 mm, 1 foot = 304.8 mm, 1 mile per hour = 0.447 m/s.

NP = Not Permitted.

a. Linear interpolation shall be permitted.

b. Use the actual length where it is greater than or equal to the minimum length.

c. Maximum header height for PFH is 10 feet in accordance with Figure R602.10.6.2, but wall height shall be permitted to be increased to 12 feet with pony wall.

d. Maximum opening header height for PFG is 10 feet in accordance with Figure R602.10.6.3, but wall height shall be permitted to be increased to 12 feet with pony wall.

e. Maximum opening header height for CS-PF is 10 feet in accordance with Figure R602.10.6.4, but wall height shall be permitted to be increased to 12 feet with pony wall

Reason: The proposed table was reorganized to place the portal frame bracing methods at the bottom of the table for clarity. This change proposal is the results of full-scale tests conducted to determine the correct way to measure portal frame height-to-leg-length aspect ratios. It is unclear from the evolution of the IRC from 2006 through the current 2015 whether the portal frame aspect ratio is dependent on the height of the portal frame or the height of the wall. With the advent of provisions that permit pony walls up to 4-feet-tall over portal frames, the distinction becomes increasingly relevant. APA conducted full-scale tests comparing the performance of conventional 8-foot-tall portals fabricated with portal leg lengths of 16 inches for an aspect ratio (portal height/portal length) of 6:1. From this testing, baseline performance values were arrived at by using cyclic testing in accordance with ASTM E2126 and evaluated using ICC-ES Acceptance Criteria AC130. This research is contained in APA Report T2014L-39 (Copies available for free download at www.apawood.org).

APA then tested 8-foot-tall portal frames with 4-foot-tall pony walls on top of them. Two sets of specimens were tested; one set with a 6:1 aspect ratio measured using the 8 foot portal height (16" portal-leg length) like the controls. The other set of specimens was constructed with a 24-inch-long portal-leg-length providing a 6:1 aspect ratio based on the 12 foot wall height.

The results of this testing indicate that measuring the aspect ratio as the portal height over the portal leg length is the appropriate way to measure the aspect ratio when pony walls are used over the portal frames. Testing further indicated that the use of a pony wall over the portal frame actually increases slightly the overall capacity of the portal frame. As such, using the "portal height" in the portal frame height-to-leg-length aspect ratio is not only a best match for walls with pony walls when compared with normal 6:1 aspect ratio walls without pony walls, it also provides increasingly conservative performance as the pony wall increases in height.

Given the results of the testing, the portal frames were placed at the bottom of the table where the "Portal Height" is appropriate for determining minimum portal leg length, leaving the upper portions of the table dependent on the "Wall Height" as is appropriate for the traditional panel-type bracing methods.

Another change is proposed for Footnotes (d) and (e). Currently, both footnotes specify a maximum opening height of 10 feet, when the figures referenced in the footnotes clearly provide for a maximum 10-foot-header height. This change corrects contradictions existent in the present edition of the code.

Cost Impact: Will not increase the cost of construction

These provisions will not increase the cost of construction. It provides information based on full scale testing that will permit slightly narrower portal frame leg lengths where appropriate based on the aspect ratio of the portal height as opposed to the wall height. The elimination of the conflict with the footnotes and the table discussed above should clarify, make the code easier to use and permit narrower panels to count toward bracing.

Report of Committee Action Hearings
--

Committee Action:

Approved as Modified

Modify as follows:

**TABLE R602.10.5
MINIMUM LENGTH OF BRACED WALL PANELS**

METHOD (See Table R602.10.4)	MINIMUM LENGTH ^a (inches)					CONTRIBUTING LENGTH (inches)	
	Wall Height						
	8 feet	9 feet	10 feet	11 feet	12 feet		
DWB, WSP, SFB, PBC, PCP, HPS, BV-WSP	48	48	48	53	58	Actual ^b	
GB	48	48	48	53	58	Double sided = Actual ^b Single sided = 0.5 x Actual ^b	
LIB	55	62	69	NP	NP	Actual ^b	
ABW	SDC A, B and C <u>ultimate design</u> wind speed < <u>140 mph</u>	28	32	34	38	42	48
	SDC D ₀ , D ₁ and D ₂ <u>ultimate design</u> wind speed < <u>140 mph</u>	32	32	34	NP	NP	
CS-G		24	27	30	33	36	Actual ^b
CS-WSP, CS-SFB	Adjacent clear opening height (inches)						
	<64	24	27	30	33	36	Actual ^b
	68	26	27	30	33	36	
	72	27	27	30	33	36	
	76	30	29	30	33	36	
	80	32	30	30	33	36	

84	35	32	32	33	36
88	38	35	33	33	36
92	43	37	35	35	36
96	48	41	38	36	36
100	---	44	40	38	38
104	---	49	43	40	39
108	---	54	46	43	41
112	---	---	50	45	43
116	---	---	55	48	45
120	---	---	60	52	48
124	---	---	---	56	51
128	---	---	---	61	54
132	---	---	---	66	58
136	---	---	---	---	62
140	---	---	---	---	66
144	---	---	---	---	72

METHOD (See Table R602.10.4)		Portal Header Height to Top of Portal Header					
		8 feet	9 feet	10 feet	11 feet	12 feet	
PFH	Supporting roof only	16	16	16	Footnote c	Footnote c	48
	Supporting one story and roof	24	24	24	Footnote c	Footnote c	48
PFG		24	27	30	Footnote d	Footnote d	1.5 x Actual ^b
CS-PF	SDC A, B and C	16	18	20	Footnote e	Footnote e	1.5 x Actual ^b
	SDC D ₀ , D ₁ and D ₂	16	18	20	Footnote e	Footnote e	Actual ^b

For SI: 1 inch = 25.4 mm, 1 foot = 304.8 mm, 1 mile per hour = 0.447 m/s.

NP = Not Permitted.

-
- a. Linear interpolation shall be permitted.
-
- b. Use the actual length where it is greater than or equal to the minimum length.
-
- c. Maximum header height for PFH is 10 feet in accordance with Figure R602.10.6.2, but wall height shall be permitted to be increased to 12 feet with pony wall.
-
- d. Maximum header height for PFG is 10 feet in accordance with Figure R602.10.6.3, but wall height shall be permitted to be increased to 12 feet with pony wall.
-
- e. Maximum header height for CS-PF is 10 feet in accordance with Figure R602.10.6.4, but wall height shall be permitted to be increased to 12 feet with pony wall.

Committee Reason: The committee approved this proposal based on the proponents published reason statement. Also, it reorganizes the table in order to place portal frames at the bottom since portal height not wall height is used. The modification corrected the wind speed at ABW to ultimate design wind speed.

Assembly Action

None

Final Action Results

RB241-16

AM

[←BACK](#)

Code Change No: RB243-16

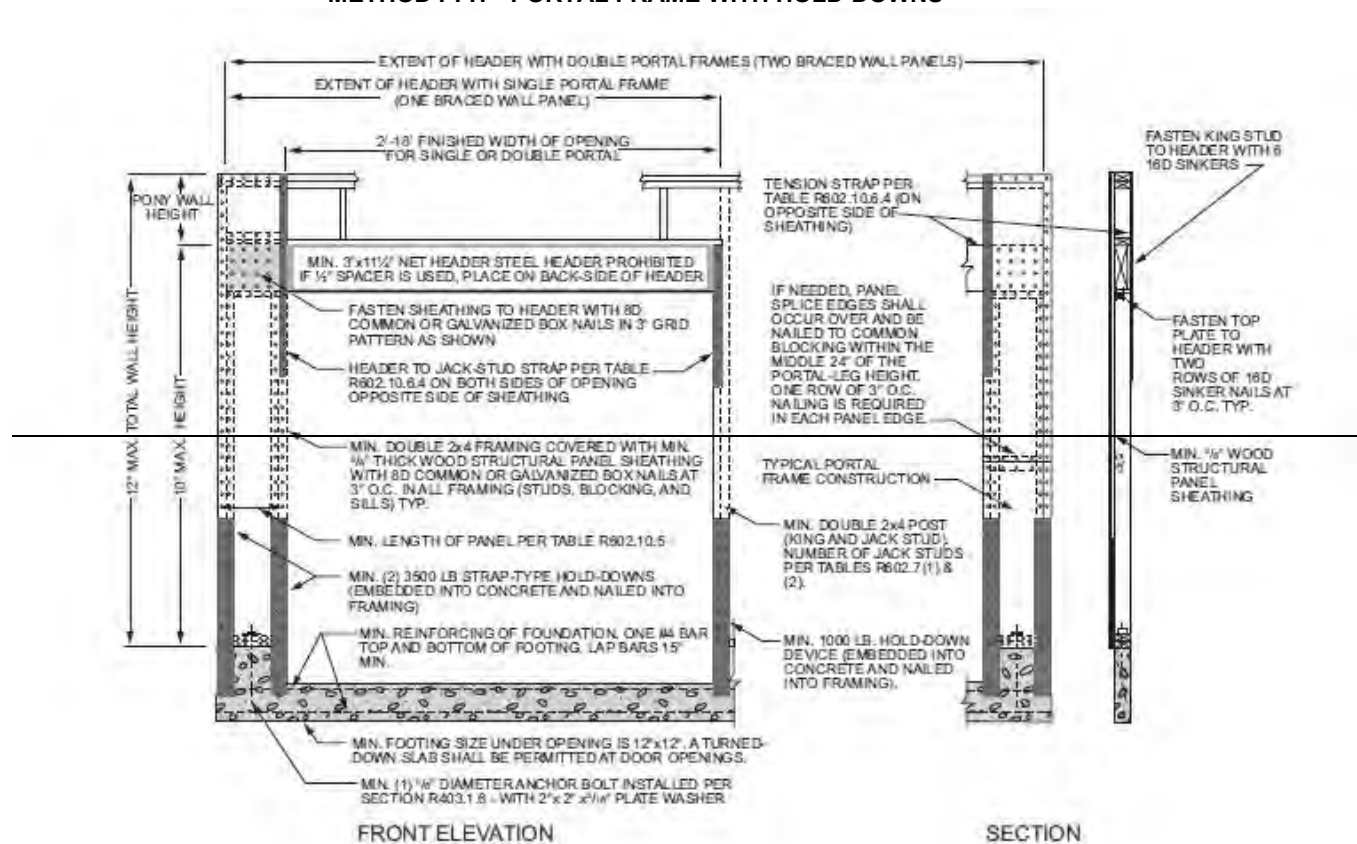
Original Proposal

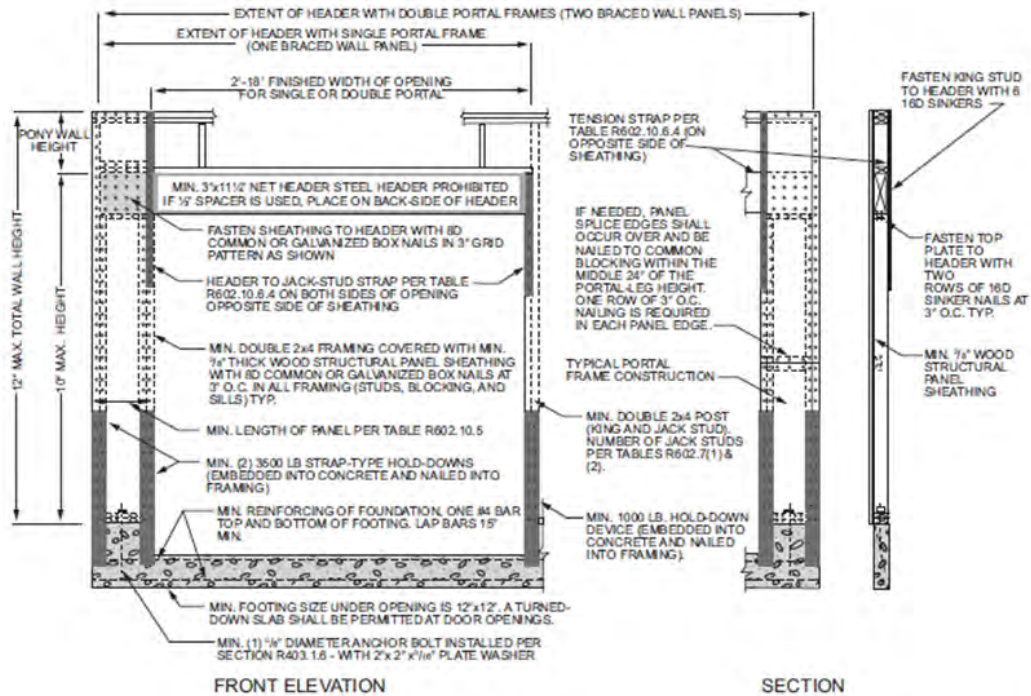
Section: R602.10.6.2

Proponent: Edward Keith, representing APA- The Engineered Wood Association (ed.keith@apawood.org)

Revise as follows:

**FIGURE R602.10.6.2
METHOD PFH—PORTAL FRAME WITH HOLD-DOWNS**





Note: Nailing of sheathing behind the 3500-lb strap shall not be required.

For SI: 1 inch = 25.4 mm, 1 foot = 304.8 mm.

FIGURE R602.10.6.2
METHOD PFH PORTAL FRAME WITH HOLD-DOWNS

For SI: 1 inch = 25.4 mm, 1 foot = 304.8 mm.

Reason: The required nailing on the 3500 lb strap provides sufficient anchorage for the wood structural panel to framing connection while prevent the potential for splitting of the framing while anchoring the strap. It also prevents the sheathing-to-framing nailing from interfering with the required strap nailing. In addition it saves time and money for the builder without compromising the effectiveness of the portal.

Cost Impact: Will not increase the cost of construction
 This change proposal will not increase the cost of construction and may save the builder a little time and money during construction without impacting the performance of the structure.

Report of Committee Action Hearings

Committee Action:

Approved as Submitted

Committee Reason: This proposal clarifies that nailing behind the strap is not required and based on the proponents published reason statement.

Assembly Action:

None

Final Action Results

RB243-16

AS

[←BACK](#)

Code Change No: **RB244-16**

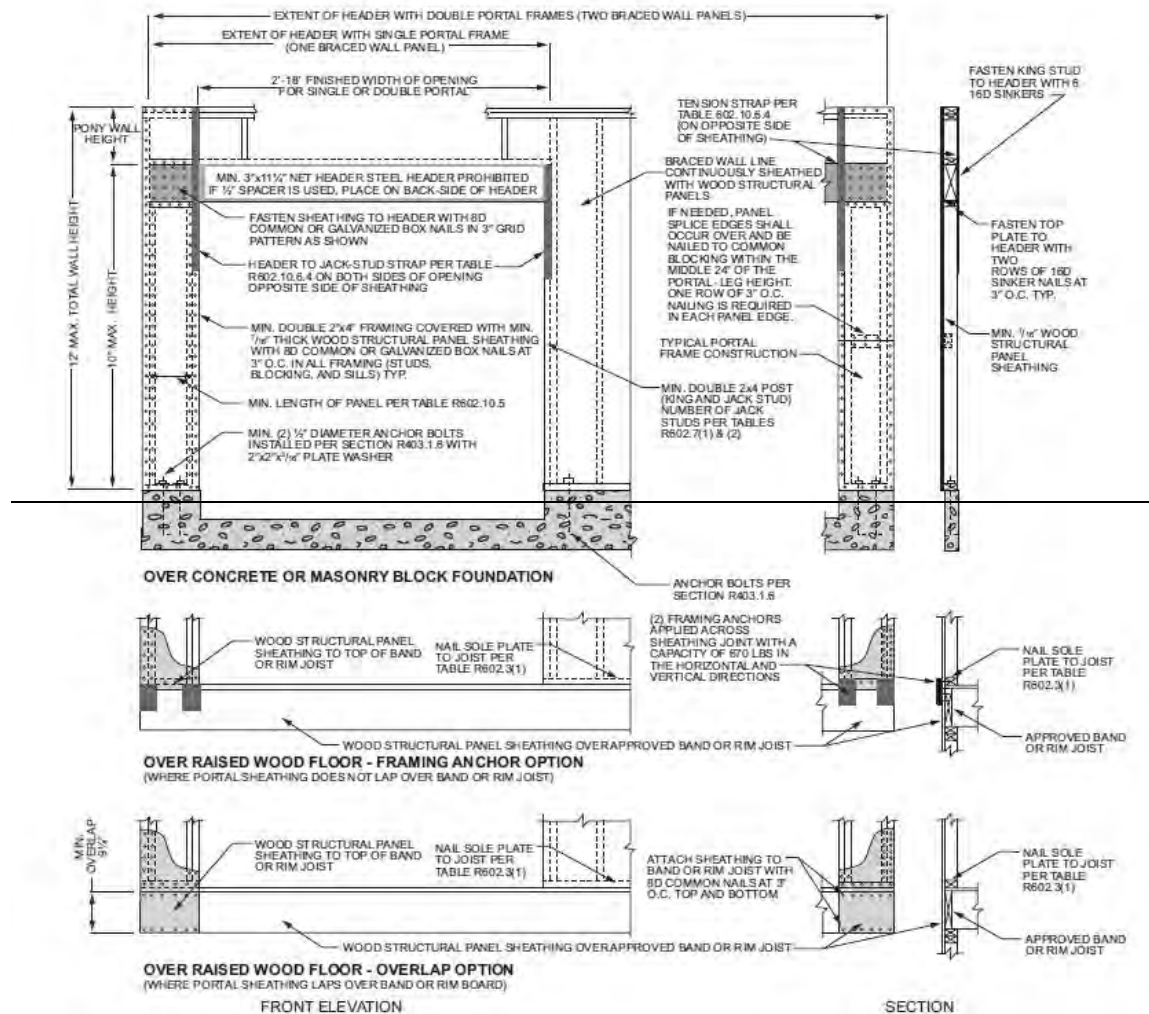
Original Proposal

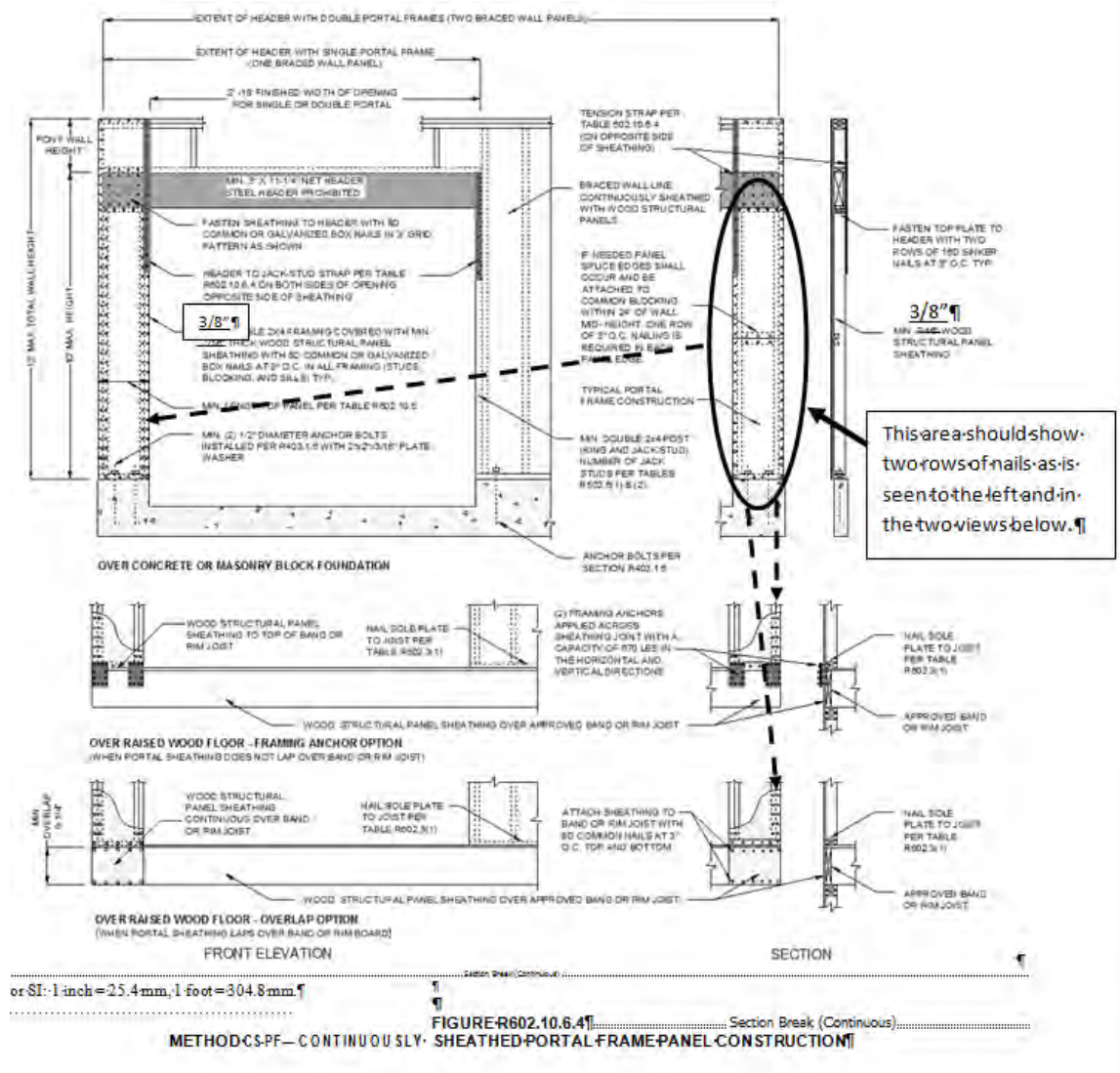
Section: R602.10.6.4

Proponent: Edward Keith, representing APA- The Engineered Wood Association (ed.keith@apawood.org)

Revise as follows:

**FIGURE R602.10.6.4
METHOD CS-PF—CONTINUOUSLY SHEATHED PORTAL FRAME PANEL CONSTRUCTION**





Report of Committee Action Hearings

Committee Action:

Approved as Submitted

Committee Reason: The committee approved this proposal based on the proponents published reason statement.

Assembly Action:

None

Final Action Results

RB244-16

AS

[←BACK](#)

Code Change No: **RB245-16**

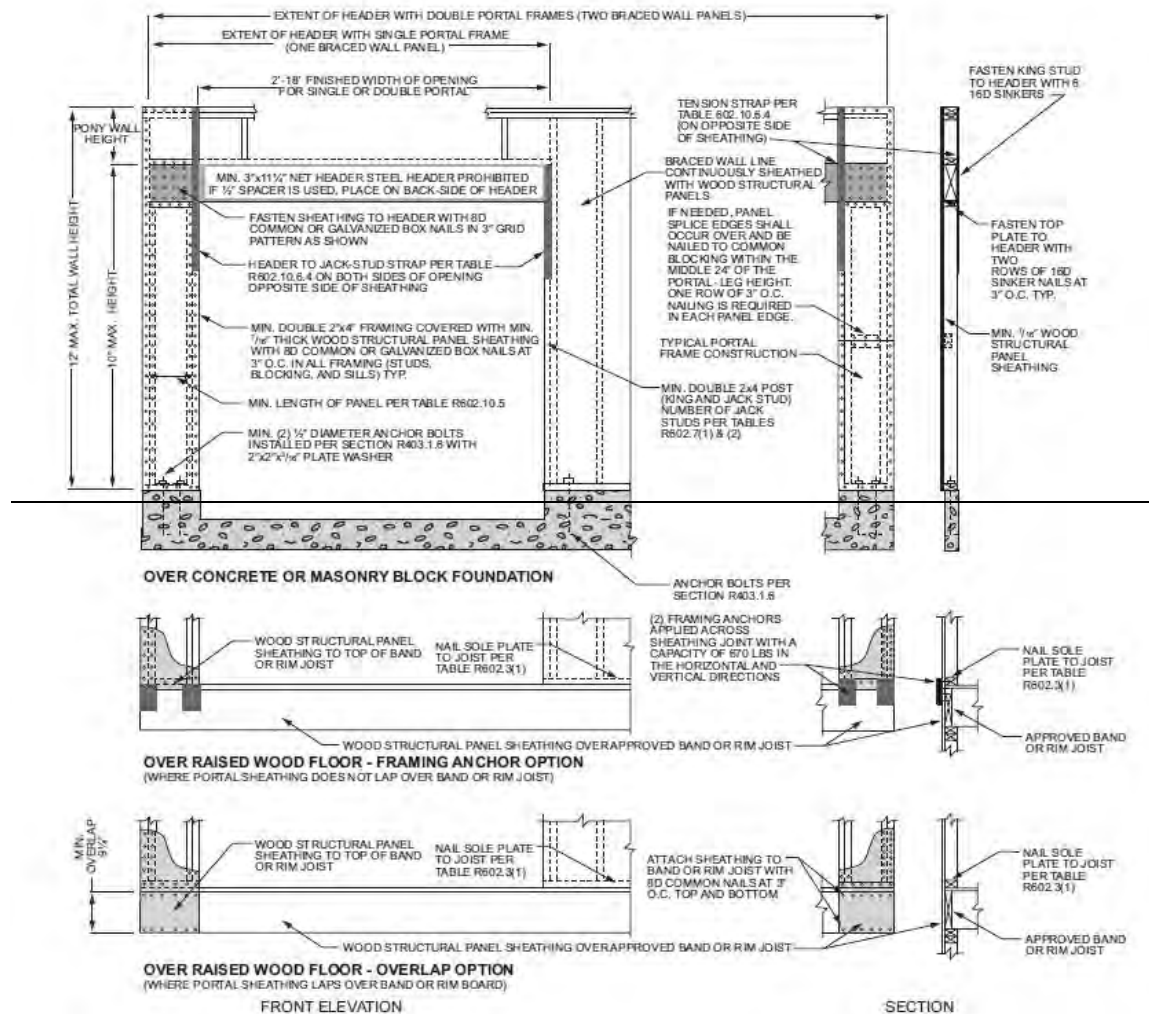
Original Proposal

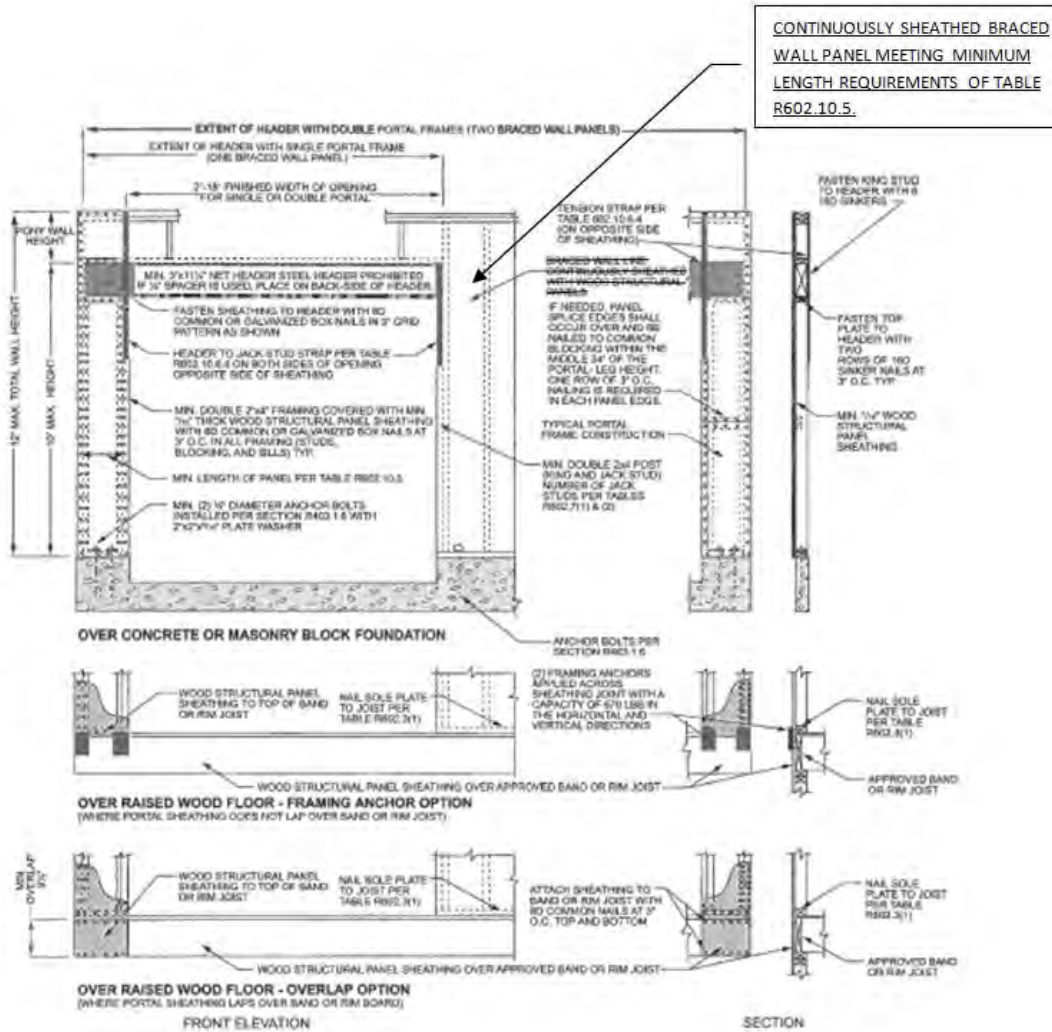
Section: R602.10.6.4

Proponent: Edward Keith, representing APA- The Engineered Wood Association (ed.keith@apawood.org)

Revise as follows:

FIGURE R602.10.6.4
METHOD CS-PF—CONTINUOUSLY SHEATHED PORTAL FRAME PANEL CONSTRUCTION





For SI: 1 inch = 25.4 mm, 1 foot = 304.8 mm.

Reason: The proposed code change more clearly states the intent of the original language. It is important that the wall element away from the single portal be well anchored to obviate the need for the anchor strap at the base of the post-end of the single-portal. This anchorage is provided by the presence of a continuously sheathed braced wall panel meeting the minimum length requirements of Table R602.10.5. The way the current figure treats the post-end sheathing requirement, any element of a continuously sheathed braced wall line, regardless of length, could be used. Even an element less than the minimum length requirements listed in Table R602.10.5 would be permitted even though such an element would not provide the necessary anchorage. This proposal modifies the language to more clearly represent the intent of the provision.

Cost Impact: Will not increase the cost of construction
This change will not increase the cost of construction as it clarifies the original intent of the code provision.

Report of Committee Action Hearings

Committee Action:

Approved as Submitted

Committee Reason: This change clarifies the need that a minimum length panel as proscribed in Table R602.10.5 is required on the side opposite the single portal.

Assembly Action:

None

Final Action Results

RB245-16

AS

[←BACK](#)

[←BACK](#)

Code Change No: RB248-16

Original Proposal

Section: R603.1.1, R603.3.1, R603.3.1.1, R603.3.2, R603.3.2.1, R603.3.5, R603.6, R603.7, R603.8, R603.9.2, R603.9.4.1

Proponent: Jon-Paul Cardin, American Iron and Steel Institute, representing American Iron and Steel Institute (JCardin@steel.org)

Revise as follows:

R603.1.1 Applicability limits. The provisions of this section shall control the construction of exterior cold-formed steel wall framing and interior load-bearing cold-formed steel wall framing for buildings not more than 60 feet (18 288 mm) long perpendicular to the joist or truss span, not more than 40 feet (12 192 mm) wide parallel to the joist or truss span, and less than or equal to three stories above grade plane. Exterior walls installed in accordance with the provisions of this section shall be considered as load-bearing walls. Cold-formed steel walls constructed in accordance with the provisions of this section shall be limited to sites where the ultimate design wind speed is less than ~~139~~140 miles per hour (~~62~~63 m/s), Exposure Category B or C, and the ground snow load is less than or equal to 70 pounds per square foot (3.35 kPa).

**TABLE R603.3.1
WALL TO FOUNDATION OR FLOOR CONNECTION REQUIREMENTS^{a, b}**

FRAMING CONDITION	ULTIMATE WIND SPEED AND EXPOSURE CATEGORY (mph)					
	115 B	126 B or 140 C <u>120 B</u>	130 B <139 B or 115 C	C <140 B or 120 C	<139 C <u>130 C</u>	<u><140 C</u>
Wall bottom track to floor per Figure R603.3.1(1)	1-No. 8 screw at 12" o.c.	1-No. 8 screw at 12"8" o.c.	4 2-No. 8 screw at 12"8" o.c.	2-No. 8 screws at 12"6" o.c.	2 3-No. 8 screws at 12"8" o.c.	<u>3</u> -No. 8 screws at <u>6"</u> o.c.
Wall bottom track to foundation per Figure R603.3.1(2) ^d	$\frac{1}{2}$ " minimum diameter anchor bolt at 6' o.c.	$\frac{1}{2}$ " minimum diameter anchor bolt at 4 <u>6</u> ' o.c.	$\frac{1}{2}$ " minimum diameter anchor bolt at 4' o.c.	$\frac{1}{2}$ " minimum diameter anchor bolt at 4' o.c.	$\frac{1}{2}$ " minimum diameter anchor bolt at 4 <u>3</u> '- <u>4</u> ' o.c.	<u>$\frac{1}{2}$"</u> minimum diameter anchor bolt at <u>2</u> '- <u>8</u> " o.c.
Wall bottom track to wood sill per Figure R603.3.1(3)	Steel plate spaced at 4' o.c., with 4-No. 8 screws and 4-10d or 6-8d common nails	Steel plate spaced at 3 <u>4</u> ' o.c., with 4-No. 8 screws and 4-10d or 6-8d common nails	Steel plate spaced at 3' o.c., with 4-No. 8 screws and 4-10d or 6-8d common nails	Steel plate spaced at 2 <u>3</u> ' o.c., with 4-No. 8 screws and 4-10d or 6-8d common nails	Steel plate spaced at 2' o.c., with 4-No. 8 screws and 4-10d or 6-8d common nails	<u>Steel plate spaced at 1</u> '- <u>4</u> " o.c., with <u>4</u> - <u>No. 8</u> screws and <u>4</u> - <u>10d</u> or <u>6</u> - <u>8d</u> common nails
Wind uplift connector strength (lbs) ^{c, e}	Stud Spacing (inches)	Roof Span (feet)				

	16	24	NR	NR	NR	<u>NR 424</u>	<u>NR209</u>	<u>NR</u>
		28	NR	NR	<u>NR62</u>	<u>NR454</u>	<u>NR249</u>	<u>339</u>
		32	NR	NR	<u>NR 79</u>	<u>NR 479</u>	<u>NR 289</u>	<u>382</u>
		36	NR	NR	<u>NR 94</u>	<u>NR 206</u>	<u>333 329</u>	<u>426</u>
		40	NR	<u>NR 64</u>	<u>NR 447</u>	<u>NR 239</u>	<u>368 374</u>	<u>470</u>
	24	24	NR	NR	<u>NR 69</u>	<u>NR 486</u>	<u>343 314</u>	<u>443</u>
		28	NR	NR	<u>NR 93</u>	<u>NR 227</u>	<u>395 374</u>	<u>508</u>
		32	NR	NR	<u>NR 447</u>	<u>330 268</u>	<u>447 434</u>	<u>573</u>
		36	NR	<u>NR 64</u>	<u>NR 444</u>	<u>371 309</u>	<u>500 494</u>	<u>639</u>
		40	NR	<u>NR 92</u>	<u>345 476</u>	<u>411 359</u>	<u>552 562</u>	<u>704</u>

For SI: 1 inch = 25.4 mm, 1 mile per hour = 0.447 m/s, 1 foot = 304.8 mm, 1 pound = 4.45 N.

- a. Anchor bolts are to be located not more than 12 inches from corners or the termination of bottom tracks such as, at door openings or corners. Bolts are to extend not less than 15 inches into masonry or 7 inches into concrete.
- b. All screw sizes shown are minimum.
- c. NR = Uplift connector not required.
- d. Foundation anchor straps are permitted in place of anchor bolts, if spaced as required to provide equivalent anchorage to the required anchor bolts and installed in accordance with manufacturer's requirements.
- e. See Figure R603.3.1(4) for details.

TABLE R603.3.1.1 (1)
GABLE ENDWALL TO FLOOR CONNECTION REQUIREMENTS^{a, b, c}

ULTIMATE BASIC WIND SPEED (mph)		WALL BOTTOM TRACK TO FLOOR JOIST OR TRACK CONNECTION		
Exposure Category		Stud height, <i>h</i> (feet)		
B	C	10 < <i>h</i> ≤ 14	14 < <i>h</i> ≤ 18	18 < <i>h</i> ≤ 22
115	—	1-No. 8 screw @ 12" o.c.	1-No. 8 screw @ 12" o.c.	1-No. 8 screw @ 12" o.c.
<u>426-120</u>	<u>440</u>	1-No. 8 screw @ 12" o.c.	1-No. 8 screw @ 12" o.c.	1-No. 8 screw @ 12" o.c.
<u><139-130</u>	115	1-No. 8 screw @ 12" o.c.	1-No. 8 screw @ 12" o.c.	2-No. 8 screws @ 12" o.c.
<u>— <140</u>	<u>426-120</u>	1-No. 8 screw @ 12" o.c.	<u>2</u> 1-No. 8 screws @ 12" o.c.	<u>4</u> 2-No. 8 screw @ <u>8"12"</u> o.c.
—	<u><139-130</u>	2-No. 8 screws @ 12" o.c.	1-No. 8 screw @ 8" o.c.	2-No. 8 screws @ 8" o.c.
<u>—</u>	<u>< 140</u>	<u>2</u> -No. 8 screws @ <u>12" o.c.</u>	<u>1</u> -No. 8 screw @ 8" o.c.	<u>2</u> -No. 8 screws @ 8" o.c.

For SI: 1 inch = 25.4 mm, 1 mile per hour = 0.447 m/s, 1 foot = 304.8 mm.

- a. Refer to Table R603.3.1.1(2) for gable endwall bottom track to foundation connections.
- b. Where attachment is not given, special design is required.
- c. Stud height, *h*, is measured from wall bottom track to wall top track or brace connection height.

TABLE R603.3.1.1 (2)
GABLE ENDWALL BOTTOM TRACK TO FOUNDATION CONNECTION REQUIREMENTS^{a, b, c}

ULTIMATE WIND SPEED (mph)		MINIMUM SPACING FOR 1/2-INCH-DIAMETER ANCHOR BOLTS ^d		
Exposure Category		Stud height, <i>h</i> (feet)		
B	C	10 < <i>h</i> ≤ 14	14 < <i>h</i> ≤ 18	18 < <i>h</i> ≤ 22
115	—	6'- 0" o.c.	<u>5'-7"6'- 0"</u> o.c.	6'- 0" o.c.
<u>426-120</u>	<u>440</u>	<u>5'-10"6'- 0"</u> o.c.	<u>6'-0"5'- 7"</u> o.c..	6'- 0" o.c.
<u><139 130</u>	115	<u>4'-10"5'- 0"</u> o.c.	<u>5'-6"6'- 0"</u> o.c.	6'- 0" o.c.
<u>— <140</u>	<u>426-120</u>	<u>4'-1"6'- 0"</u> o.c.	<u>6'-0"5'- 6"</u> o.c.	6'- 0" o.c.
—	<u><139 130</u>	<u>5'-1"5'- 3"</u> o.c.	6'- 0" o.c.	<u>5'-2"6'- 0"</u> o.c.

—	<140	3'- 0" o.c.	3'- 0" o.c.	3'- 0" o.c.
---	------	-------------	-------------	-------------

For SI: 1 inch = 25.4 mm, 1 mile per hour = 0.447 m/s, 1 foot = 304.8 mm.

- a. Refer to Table R603.3.1.1(1) for gable endwall bottom track to floor joist or track connection connections.
- b. Where attachment is not given, special design is required.
- c. Stud height, *h*, is measured from wall bottom track to wall top track or brace connection height.
- d. Foundation anchor straps are permitted in place of anchor bolts if spaced as required to provide equivalent anchorage to the required anchor bolts and installed in accordance with manufacturer's requirements.

TABLE R603.3.2 (2)
24-FOOT-WIDE BUILDING SUPPORTING ROOF AND CEILING ONLY^{a, b, c, d}

ULTIMATE WIND SPEED AND EXPOSURE CATEGORY (mph)		MEMBER SIZE	STUD SPACING (inches)	MINIMUM STUD THICKNESS (mils)												
				8-foot Studs				9-foot Studs				10-foot Studs				
Exp. B	Exp. C	Ground Snow Load (psf)														
		20	30	50	70	20	30	50	70	20	30	50	70			
115	—	350S162	16	33	33	33	33	33	33	33	33	33	33	33	33	
			24	33	33	33	43	33	33	33	43	33	33	43	43	
		550S162	16	33	33	33	33	33	33	33	33	33	33	33	33	33
			24	33	33	33	33	33	33	33	33	33	33	33	33	33 43
126 120	110 —	350S162	16	33	33	33	33	33	33	33	33	33	33	33	33	
			24	33	33	33	43	33	33	33	43	43	43	43		
		550S162	16	33	33	33	33	33	33	33	33	33	33	33	33	
			24	33	33	33	43	33	33	33	33	33	33	33	43	
<139 130	115	350S162	16	33	33	33	33	33	33	33	33	33	33	33	33	
			24	33	33	33 43	43	43	43	43	43	43	43	54		
		550S162	16	33	33	33	33	33	33	33	33	33	33	33	33	
			24	33	33	33	43	33	33	33	33 43	43 33	43 33	43 33	43	
— <140	126 120	350S162	16	33	33	33	33	33	33	33	33	33	43 33	43 33	43 33	43
			24	43 33	43 33	43	43	43	43	43	43	54	54	54	54	
		550S162	16	33	33	33	33	33	33	33	33	33	33	33	33	
			24	33	33	33	43	43 33	43 33	43 33	43	43	43	43	43	
—	<139 130	350S162	16	33	33	33	33	43 33	43 33	43 33	43 33	43	43	43	43	
			24	43	43	43	43	54	54	54	54	54	54	54		
		550S162	16	33	33	33	33	33	33	33	33	33	33	33	33	
			14	33	43 33	43 33	43	43	43	43	43	43	43	43	43	
=	<140	350S162	16	<u>33</u>	<u>33</u>	<u>33</u>	<u>33</u>	<u>43</u>	<u>43</u>	<u>43</u>	<u>43</u>	<u>43</u>	<u>43</u>	<u>43</u>	<u>43</u>	
			24	<u>43</u>	<u>43</u>	<u>43</u>	<u>54</u>	<u>54</u>	<u>54</u>	<u>54</u>	<u>54</u>	<u>54</u>	<u>54</u>	<u>54</u>		
		550S162	16	<u>33</u>	<u>33</u>	<u>33</u>	<u>33</u>	<u>33</u>	<u>33</u>	<u>33</u>	<u>33</u>	<u>33</u>	<u>33</u>	<u>33</u>	<u>33</u>	
			24	<u>43</u>	<u>43</u>	<u>43</u>	<u>43</u>	<u>43</u>	<u>43</u>	<u>43</u>	<u>43</u>	<u>43</u>	<u>43</u>	<u>43</u>	<u>43</u>	

For SI: 1 inch = 25.4 mm, 1 foot = 304.8 mm, 1 mil = 0.0254 mm, 1 mile per hour = 0.447 m/s, 1 pound per square foot = 0.0479 kPa, 1 ksi = 1,000 psi = 6.895 MPa.

a. Deflection criterion: $L/240$.

b. Design load assumptions:

Second-floor dead load is 10 psf.

Second-floor live load is 30 psf.

Roof/ceiling dead load is 12 psf.

Attic live load is 10 psf.

c. Building width is in the direction of horizontal framing members supported by the wall studs.

d. Minimum Grade 33 ksi steel shall be used for 33 mil and 43 mil thicknesses. Minimum Grade 50 ksi steel shall be used for 54 and 68 mil thicknesses.

TABLE R603.3.2 (3)
28-FOOT-WIDE BUILDING SUPPORTING ROOF AND CEILING ONLY^{a, b, c, d}

ULTIMATE WIND SPEED AND EXPOSURE CATEGORY (mph)		MEMBER SIZE	STUD SPACING (inches)	MINIMUM STUD THICKNESS (mils)														
				8-foot Studs				9-foot Studs				10-foot Studs						
Exp. B	Exp. C			Ground Snow Load (psf)														
				20	30	50	70	20	30	50	70	20	30	50	70			
115	—	350S162	16	33	33	33	33	33	33	33	33	33	33	33	33	33	33	
			24	33	33	43	43	33	33	43	43	33	33	43	33	43	54	
		550S162	16	33	33	33	33	33	33	33	33	33	33	33	33	33	33	33
			24	33	33	33	43	33	33	33	43	33	33	33	33	33	33	43
126 120	110 —	350S162	16	33	33	33	33	33	33	33	33	33	33	33	33	33	33	
			24	33	33	43	43	33	33	43	43	43	43	43	43	54		
		550S162	16	33	33	33	33	33	33	33	33	33	33	33	33	33	33	33
			24	33	33	33	43	33	33	33	43	33	33	33	33	33	33	43
<139 130	115	350S162	16	33	33	33	33	33	33	33	33	33	33	33	33	33	43	
			24	33	33	43	43-54	43	43	43	43-54	43	43	43	54			
		550S162	16	33	33	33	33	33	33	33	33	33	33	33	33	33	33	
			24	33	33	33	43	33	33	33	43	43 33	43 33	43 33	43 33	43		
—<140	126-120	350S162	16	33	33	33	33	33	33	33	33	33	43 33	43 33	43 33	43		
			24	43-33	43 33	43	54	43	43	43	54	54	54	54	54			
		550S162	16	33	33	33	33	33	33	33	33	33	33	33	33	33	33	
			24	33	33	33	43	43 33	43 33	43 33	43	43	43	43	43			
—	<139 130	350S162	16	33	33	33	33	43 33	43 33	43 33	43	43	43	43	43			
			24	43	43	43	54	54	54	54	54	54	54	54				
		550S162	16	33	33	33	33	33	33	33	33	33	33	33	33			
			24	43-33	43 33	43 33	43	43	43	43	43	43	43	43	43			
=	< 140	350S162	16	33	33	33	43	43	43	43	43	43	43	43				
			24	43	43	43	54	54	54	54	54	54	54					
		550S162	16	33	33	33	33	33	33	33	33	33	33	33				

			<u>24</u>	<u>43</u>	<u>43</u>	<u>43</u>	<u>43</u>	<u>43</u>	<u>43</u>	<u>43</u>	<u>43</u>	<u>43</u>	<u>43</u>	<u>43</u>	<u>43</u>
--	--	--	-----------	-----------	-----------	-----------	-----------	-----------	-----------	-----------	-----------	-----------	-----------	-----------	-----------

For SI: 1 inch = 25.4 mm, 1 foot = 304.8 mm, 1 mil = 0.0254 mm, 1 mile per hour = 0.447 m/s, 1 pound per square foot = 0.0479 kPa, 1 ksi = 1,000 psi = 6.895 MPa.

- a. Deflection criterion: $L/240$.
- b. Design load assumptions:
 Second-floor dead load is 10 psf.
 Second-floor live load is 30 psf.
 Roof/ceiling dead load is 12 psf.
 Attic live load is 10 psf.
- c. Building width is in the direction of horizontal framing members supported by the wall studs.
- d. Minimum Grade 33 ksi steel shall be used for 33 mil and 43 mil thicknesses. Minimum Grade 50 ksi steel shall be used for 54 and 68 mil thicknesses.

TABLE R603.3.2 (4)
32-FOOT-WIDE BUILDING SUPPORTING ROOF AND CEILING ONLY^{a, b, c, d}

ULTIMATE WIND SPEED AND EXPOSURE CATEGORY (mph)		MEMBER SIZE	STUD SPACING (inches)	MINIMUM STUD THICKNESS (mils)											
				8-foot Studs				9-foot Studs				10-foot Studs			
Exp. B	Exp. C	Ground Snow Load (psf)													
		20	30	50	70	20	30	50	70	20	30	50	70		
115	—	350S162	16	33	33	33	33	33	33	33	33	33	33	33	33
			24	33	33	43	54	33	33	43	43 54	33 43	33 43	43	54
		550S162	16	33	33	33	33	33	33	33	33	33	33	33	33
			24	33	33	33	43	33	33	33	43	33	33	33	43
126-120	140 —	350S162	16	33	33	33	33	33	33	33	33	33	33	33	43
			24	33	33	43	54	33	33	43	54	43	43	43	54
		550S162	16	33	33	33	33	33	33	33	33	33	33	33	33
			24	33	33	33	43	33	33	33	43	33	33	33 43	43
<139 <u>130</u>	115	350S162	16	33	33	33	43	33	33	33	33	33 43	33	33	43
			24	33	33	43	54	43	43	43	54	43	43	43 54	54
		550S162	16	33	33	33	33	33	33	33	33	33	33	33	33
			24	33	33	33 43	43	33	33	33	43	43 33	43 33	43	43
— <140	126-120	350S162	16	33	33	33	43	33	33	33	43	43 33	43 33	43 33	43
			24	43 33	43 33	43	54	43	43	43	54	54	54	54	54
		550S162	16	33	33	33	33	33	33	33	33	33	33	33	33
			24	33	33	43	43	43 33	43 33	43 33	43	43	43	43	43
—	<139 <u>130</u>	350S162	16	33	33	33	43	43 33	43 33	43 33	43	43	43	43	43
			24	43	43	43	54	54	54	54	54	54	54	54	54
		550S162	16	33	33	33	33	33	33	33	33	33	33	33	33
			24	43 33	43 33	43	43	43	43	43	43	43	43	43	43
=	< 140	350S162	<u>16</u>	<u>33</u>	<u>33</u>	<u>33</u>	<u>43</u>	<u>43</u>	<u>43</u>	<u>43</u>	<u>43</u>	<u>43</u>	<u>43</u>	<u>43</u>	<u>43</u>
			<u>24</u>	<u>43</u>	<u>43</u>	<u>54</u>	<u>54</u>	<u>54</u>	<u>54</u>	<u>54</u>	<u>54</u>	<u>54</u>	<u>54</u>	<u>54</u>	<u>54</u>

		550S162	<u>16</u>	<u>33</u>	<u>33</u>	<u>33</u>	<u>33</u>	<u>33</u>	<u>33</u>	<u>33</u>	<u>33</u>	<u>33</u>	<u>33</u>	<u>33</u>	<u>33</u>
			<u>24</u>	<u>43</u>	<u>43</u>	<u>43</u>	<u>43</u>	<u>43</u>	<u>43</u>	<u>43</u>	<u>43</u>	<u>43</u>	<u>43</u>	<u>43</u>	<u>43</u>

For SI: 1 inch = 25.4 mm, 1 foot = 304.8 mm, 1 mil = 0.0254 mm, 1 mile per hour = 0.447 m/s, 1 pound per square foot = 0.0479 kPa, 1 ksi = 1,000 psi = 6.895 MPa.

- a. Deflection criterion: $L/240$.
- b. Design load assumptions:
 Second-floor dead load is 10 psf.
 Second-floor live load is 30 psf.
 Roof/ceiling dead load is 12 psf.
 Attic live load is 10 psf.
- c. Building width is in the direction of horizontal framing members supported by the wall studs.
- d. Minimum Grade 33 ksi steel shall be used for 33 mil and 43 mil thicknesses. Minimum Grade 50 ksi steel shall be used for 54 and 68 mil thicknesses.

TABLE R603.3.2 (5)
36-FOOT-WIDE BUILDING SUPPORTING ROOF AND CEILING ONLY^{a, b, c, d}

ULTIMATE WIND SPEED AND EXPOSURE CATEGORY (mph)		MEMBER SIZE	STUD SPACING (inches)	MINIMUM STUD THICKNESS (mils)												
				8-foot Studs				9-foot Studs				10-foot Studs				
				Ground Snow Load (psf)												
Exp. B	Exp. C			20	30	50	70	20	30	50	70	20	30	50	70	
115	—	350S162	16	33	33	33	43	33	33	33	43	33	33	33	43	
			24	33	33	43	54	33	33	43	54	33 43	43	54	54	
		550S162	16	33	33	33	33	33	33	33	33	33	33	33	33	33
			24	33	33	43	43	33	33	43	43	33	33	43	43	43
126 120	140	350S162	16	33	33	33	43	33	33	33	43	33	33	33	43	
			24	33	33	43	54	33	33	43	54	43	43	54	54	
		550S162	16	33	33	33	33	33	33	33	33	33	33	33	33	33
			24	33	33	43	43	33	33	43	43	33	33	43	43	43
139 130	115	350S162	16	33	33	33	43	33	33	33	33 43	33	33	43	43	
			24	33	33 43	43	54	43	43	43	43 54	43	43	54	54	
		550S162	16	33	33	33	33	33	33	33	33	33	33	33	33	33
			24	33	33	43	43	33	33	43	43	43 33	43 33	43	43	
140	126 120	350S162	16	33	33	33	43	33	33	33	43 33	33	33	43	43	
			24	43	43	43	54	43	43	43	54	54	54	54	54	
		550S162	16	33	33	33	33	33	33	33	33	33	33	33	33	33
			24	33	33	43	43	43 33	43 33	43	43	43	43	43	43	43 54
—	139 130	350S162	16	33	33	33	43	43 33	43 33	43 33	43	43	43	43	43	
			24	43	43	54	54	54	54	54	54	54	54	54	54	
		550S162	16	33	33	33	33	33	33	33	33	33	33	33	33	33 43
			24	43 33	43 33	43	54	43	33 43	43	43	43	43	43	43	54
=	<140	350S162	16	33	33	33	43	43	43	43	43	43	43	43	54	
			24	43	43	54	54	54	54	54	54	54	54	54	68	
		550S162	16	33	33	33	33	33	33	33	33	33	33	33	33	43

			<u>24</u>	<u>43</u>	<u>43</u>	<u>43</u>	<u>54</u>	<u>43</u>	<u>43</u>	<u>43</u>	<u>43</u>	<u>43</u>	<u>43</u>	<u>43</u>	<u>54</u>
--	--	--	-----------	-----------	-----------	-----------	-----------	-----------	-----------	-----------	-----------	-----------	-----------	-----------	-----------

For SI: 1 inch = 25.4 mm, 1 foot = 304.8 mm, 1 mil = 0.0254 mm, 1 mile per hour = 0.447 m/s, 1 pound per square foot = 0.0479 kPa, 1 ksi = 1,000 psi = 6.895 MPa.

- a. Deflection criterion: $L/240$.
- b. Design load assumptions:
 Second-floor dead load is 10 psf.
 Second-floor live load is 30 psf.
 Roof/ceiling dead load is 12 psf.
 Attic live load is 10 psf.
- c. Building width is in the direction of horizontal framing members supported by the wall studs.
- d. Minimum Grade 33 ksi steel shall be used for 33 mil and 43 mil thicknesses. Minimum Grade 50 ksi steel shall be used for 54 and 68 mil thicknesses.

TABLE R603.3.2 (6)
40-FOOT-WIDE BUILDING SUPPORTING ROOF AND CEILING ONLY^{a, b, c, d}

ULTIMATE WIND SPEED AND EXPOSURE CATEGORY (mph)		MEMBER SIZE	STUD SPACING (inches)	MINIMUM STUD THICKNESS (mils)												
				8-foot Studs				9-foot Studs				10-foot Studs				
				Ground Snow Load (psf)												
Exp. B	Exp. C			20	30	50	70	20	30	50	70	20	30	50	70	
115	—	350S162	16	33	33	33	43	33	33	33	43	33	33	33 43	43	
			24	33	33	43	54	33	33 43	43	54	43	43	54	54	
		550S162	16	33	33	33	43	33	33	33	33	33	33	33	33	33
			24	33	33	43	54	33	33	43	43	43	33	33	43	54
426-120	440—	350S162	16	33	33	33	43	33	33	33	43	33	33	43	43	
			24	33	43	43	54	33	43	43	54	43	43	54	54	
		550S162	16	33	33	33	43	33	33	33	33	33	33	33	33 43	43
			24	33	33	43	54	33	33	43	43	43	33	33	43	54
<139 130	115	350S162	16	33	33	33	43	33	33	33	43	33	33	43	43	
			24	33 43	43	43 54	54	43	43	43 54	54	43	43 54	54	54	
		550S162	16	33	33	33	43	33	33	33	33	33	33	33	33	43
			24	33	33	43	54	33	33	43	43 54	43 33	43 33	43	54	
—<140	426-120	350S162	16	33	33	33	43	33	33	33	43	43 33	43 33	43	43	
			24	43	43	54	54	43	43	54	54	54	54	54	54	
		550S162	16	33	33	33	43	33	33	33	33	33	33	33	33	43
			24	33	33	43	54	43 33	43 33	43	54	43	43	43	43	54
—	<139 130	350S162	16	33	33	43	43	43 33	43 33	43	43	43	43	43	54	
			24	43	43	54	54	54	54	54	54	54	54	54	68	
		550S162	16	33	33	33	43	33	33	33	43	33	33	33	43	
			24	43 33	43 33	43	54	43	43	43	54	43	43	43	54	
=	<140	350S162	16	33	33	43	43	43	43	43	43	43	43	43	54	
			24	43	43	54	54	54	54	54	54	54	54	54	68	
		550S162	16	33	33	33	43	33	33	33	43	33	33	33	43	
			24	33	33	33	43	33	33	33	43	33	33	33	43	

			<u>24</u>	<u>43</u>	<u>43</u>	<u>43</u>	<u>54</u>	<u>43</u>	<u>43</u>	<u>43</u>	<u>54</u>	<u>43</u>	<u>43</u>	<u>43</u>	<u>54</u>
--	--	--	-----------	-----------	-----------	-----------	-----------	-----------	-----------	-----------	-----------	-----------	-----------	-----------	-----------

For SI: 1 inch = 25.4 mm, 1 foot = 304.8 mm, 1 mil = 0.0254 mm, 1 mile per hour = 0.447 m/s, 1 pound per square foot = 0.0479 kPa, 1 ksi = 1,000 psi = 6.895 MPa.

- a. Deflection criterion: $L/240$.
- b. Design load assumptions:
 Second-floor dead load is 10 psf.
 Second-floor live load is 30 psf.
 Roof/ceiling dead load is 12 psf.
 Attic live load is 10 psf.
- c. Building width is in the direction of horizontal framing members supported by the wall studs.
- d. Minimum Grade 33 ksi steel shall be used for 33 mil and 43 mil thicknesses. Minimum Grade 50 ksi steel shall be used for 54 and 68 mil thicknesses.

TABLE R603.3.2 (7)
24-FOOT-WIDE BUILDING SUPPORTING ONE FLOOR, ROOF AND CEILING^{a, b, c, d}

ULTIMATE WIND SPEED AND EXPOSURE CATEGORY (mph)		MEMBER SIZE	STUD SPACING (inches)	MINIMUM STUD THICKNESS (mils)													
				8-foot Studs				9-foot Studs				10-foot Studs					
				Ground Snow Load (psf)													
Exp. B	Exp. C			20	30	50	70	20	30	50	70	20	30	50	70		
115	—	350S162	16	33	33	33	33	33	33	33	33	33	33	33	33	43	
			24	33	33	43	43	33 43	43	43	43	43	43	43	43	43	54
		550S162	16	33	33	33	33	33	33	33	33	33	33	33	33	33	33
			24	33	33	33	43	33	33	33	43	33	33	33	33	33	43
<u>126-120</u>	<u>110-115</u>	350S162	16	33	33	33	33	33	33	33	33	33	33	33	33	43	
			24	33 43	43	43	43	43	43	43	43	43	43	43	43 54	54	
		550S162	16	33	33	33	33	33	33	33	33	33	33	33	33	33	33
			24	33	33	33	43	33	33	33	43	33	33	33	33	33	43
130-130 <u>130</u>	115	350S162	16	33	33	33	43	33	33	33	33 43	33 43	33 43	43	43		
			24	43	43	43	43 54	43	43	43 54	43 54	54	54	54	54		
		550S162	16	33	33	33	33	33	33	33	33	33	33	33	33	33	
			24	33	33	33	43	33	33	33	43	43 33	43 33	43	43		
— <u><140</u>	<u>126-120</u>	350S162	16	33	33	33	43	33	33	33 43	43	43	43	43	43		
			24	43	43	43	54	43	43 54	54	54	54	54	54	54		
		550S162	16	33	33	33	33	33	33	33	33	33	33	33	33	33	
			24	33	33	33 43	43	43 33	43 33	43 33	43	43	43	43	43		
—	130-130 <u>130</u>	350S162	16	33	33	33	43	43	43	43	43	43	43	43	43 54		
			24	43	43	43 54	54	54	54	54	54	54	54	54			
		550S162	16	33	33	33	33	33	33	33	33	33	33	33	33		

			24	43 33	43 33	43	43	43	43	43	43	43	43	43		
=	<140	350S162	16	43	43	43	43	43	43	43	43	54	54	54	54	
			24	54	54	54	54	54	54	54	54	54	54	54	54	
		550S162	16	33	33	33	33	33	33	33	33	33	33	33	33	33
			24	43	43	43	43	43	43	43	43	43	43	43	43	43

For SI: 1 inch = 25.4 mm, 1 foot = 304.8 mm, 1 mil = 0.0254 mm, 1 mile per hour = 0.447 m/s, 1 pound per square foot = 0.0479 kPa, 1 ksi = 1,000 psi = 6.895 MPa.

- a. Deflection criterion: $L/240$.
- b. Design load assumptions:
 Second-floor dead load is 10 psf.
 Second-floor live load is 30 psf.
 Roof/ceiling dead load is 12 psf.
 Attic live load is 10 psf.
- c. Building width is in the direction of horizontal framing members supported by the wall studs.
- d. Minimum Grade 33 ksi steel shall be used for 33 mil and 43 mil thicknesses. Minimum Grade 50 ksi steel shall be used for 54 and 68 mil thicknesses.

TABLE R603.3.2 (8)
28-FOOT-WIDE BUILDING SUPPORTING ONE FLOOR, ROOF AND CEILING^{a, b, c, d}

ULTIMATE WIND SPEED AND EXPOSURE CATEGORY (mph)		MEMBER SIZE	STUD SPACING (inches)	MINIMUM STUD THICKNESS (mils)												
				8-foot Studs				9-foot Studs				10-foot Studs				
				Ground Snow Load (psf)												
Exp. B	Exp. C			20	30	50	70	20	30	50	70	20	30	50	70	
115	—	350S162	16	33	33	33	43	33	33	33	43	33	33	43	43	
			24	43	43	43	54	43	43	43	54	43	43	43 54	54	
		550S162	16	33	33	33	33	33	33	33	33	33	33	33	33	33
			24	33	33	43	43	33	33	43	43	33	33	43	43	
126-120	110—	350S162	16	33	33	33	43	33	33	33	43	33	33	43	43	
			24	43	43	43	54	43	43	43	54	43 54	43 54	54	54	
		550S162	16	33	33	33	33	33	33	33	33	33	33	33	33	
			24	33	33	43	43	33	33	43	43	33	33	43	43	
<139 130	115	350S162	16	33	33	33	43	33	33	33 43	43	43	43	43	43	
			24	43	43	43	54	43	43 54	43 54	54	54	54	54	54	
		550S162	16	33	33	33	33	33	33	33	33	33	33	33	33	
			24	33	33	43	43	33	33	43	43	43	43	43	43	
—<140	126-120	350S162	16	33	33	33	43	33 43	33 43	43	43	43	43	43	43	
			24	43	43	43 54	54	54	54	54	54	54	54	54	54	
		550S162	16	33	33	33	33	33	33	33	33	33	33	33	33	
			24	33	33	43	43	43 33	43 33	43	43	43	43	43	43	
—	<139 130	350S162	16	33	33	43	43	43	43	43	43	43	43	43 54	54	
			24	43 54	43 54	54	54	54	54	54	54	54	54	54	54	
		550S162	16	33	33	33	33	33	33	33	33	33	33	33	33 43	
			24	43 33	43 33	43	43	43	43	43	43	43	43	43	43	
=	<140	350S162	16	43	43	43	43	43	43	43	43	43	54	54	54	54
			24	54	54	54	54	54	54	54	54	54	54	54	54	

		550S162	<u>16</u>	<u>33</u>	<u>33</u>	<u>33</u>	<u>33</u>	<u>33</u>	<u>33</u>	<u>33</u>	<u>33</u>	<u>33</u>	<u>33</u>	<u>33</u>	<u>43</u>
			<u>24</u>	<u>43</u>	<u>43</u>	<u>43</u>	<u>43</u>	<u>43</u>	<u>43</u>	<u>43</u>	<u>43</u>	<u>43</u>	<u>43</u>	<u>43</u>	<u>43</u>

For SI: 1 inch = 25.4 mm, 1 foot = 304.8 mm, 1 mil = 0.0254 mm, 1 mile per hour = 0.447 m/s, 1 pound per square foot = 0.0479 kPa, 1 ksi = 1,000 psi = 6.895 MPa.

- a. Deflection criterion: $L/240$.
- b. Design load assumptions:
 Second-floor dead load is 10 psf.
 Second-floor live load is 30 psf.
 Roof/ceiling dead load is 12 psf.
 Attic live load is 10 psf.
- c. Building width is in the direction of horizontal framing members supported by the wall studs.
- d. Minimum Grade 33 ksi steel shall be used for 33 mil and 43 mil thicknesses. Minimum Grade 50 ksi steel shall be used for 54 and 68 mil thicknesses.

TABLE R603.3.2 (9)
32-FOOT-WIDE BUILDING SUPPORTING ONE FLOOR, ROOF AND CEILING^{a, b, c, d}

ULTIMATE WIND SPEED AND EXPOSURE CATEGORY (mph)		MEMBER SIZE	STUD SPACING (inches)	MINIMUM STUD THICKNESS (mils)												
				8-foot Studs				9-foot Studs				10-foot Studs				
Exp. B	Exp. C	Ground Snow Load (psf)														
		20	30	50	70	20	30	50	70	20	30	50	70			
115	—	350S162	16	33	33	33	43	33	33	33	43	33	33 43	43	43	
			24	43	43	43	54	43	43	43	54	43 54	43 54	54	54	
		550S162	16	33	33	33	43	33	33	33	33	33	33	33	33	43
			24	33	43	43	54	33	33	43	43	33	33	43	43	43
126-120 140	—	350S162	16	33	33	33	43	33	33	33	43	33 43	43	43	43	
			24	43	43	43	54	43	43	43	54	54	54	54	54	
		550S162	16	33	33	33	43	33	33	33	33	33	33	33	33	43
			24	33	43	43	54	33	33	43	43	33	33	43	43 54	54
139 130	115	350S162	16	33	33	43	43	33 43	33 43	33 43	43	43	43	43	43	
			24	43	43	54	54	43 54	43 54	54	54	54	54	54	54	
		550S162	16	33	33	33	43	33	33	33	33	33	33	33	33	43
			24	33	43	43	54	33	33	43	43	43	43	43	43	54
140	126-120	350S162	16	33	33	43	43	43	43	43	43	43	43	43	43 54	
			24	43	43 54	54	54	54	54	54	54	54	54	54	54	
		550S162	16	33	33	33	43	33	33	33	33 43	33	33	33	43	
			24	33	43	43	54	43 33	43	43	43	43	43	43	54	
—	139 130	350S162	16	43	43	43	43	43	43	43	43	43	43 54	54	54	
			24	54	54	54	54	54	54	54	54	54	54	54	54	
		550S162	16	33	33	33	43	33	33	33	43	33	33	33	43	
			24	33	33	33	43	33	33	33	43	33	33	33	43	

			24	43	43	43	54	43	43	43	43	43 54	43	43	43	54
—	<140	350S162	16	43	43	43	43	43	43	43	43	54	54	54	54	54
			24	54	54	54	54	54	54	54	54	54	54	54	54	68
		550S162	16	33	33	33	43	33	33	33	43	33	33	33	33	43
			24	43	43	43	54	43	43	43	54	43	43	43	43	54

For SI: 1 inch = 25.4 mm, 1 foot = 304.8 mm, 1 mil = 0.0254 mm, 1 mile per hour = 0.447 m/s, 1 pound per square foot = 0.0479 kPa, 1 ksi = 1,000 psi = 6.895 MPa.

a. Deflection criterion: L/240.

b. Design load assumptions:

Second-floor dead load is 10 psf.

Second-floor live load is 30 psf.

Roof/ceiling dead load is 12 psf.

Attic live load is 10 psf.

c. Building width is in the direction of horizontal framing members supported by the wall studs.

d. Minimum Grade 33 ksi steel shall be used for 33 mil and 43 mil thicknesses. Minimum Grade 50 ksi steel shall be used for 54 and 68 mil thicknesses.

TABLE R603.3.2 (10)
36-FOOT-WIDE BUILDING SUPPORTING ONE FLOOR, ROOF AND CEILING^{a, b, c, d}

ULTIMATE WIND SPEED AND EXPOSURE CATEGORY (mph)		MEMBER SIZE	STUD SPACING (inches)	MINIMUM STUD THICKNESS (mils)													
				8-foot Studs				9-foot Studs				10-foot Studs					
Exp. B		Exp. C			Ground Snow Load (psf)												
					20	30	50	70	20	30	50	70	20	30	50	70	
115	—	350S162	16	33	33	43	43	33	33	43	43	33	33	43	43	43	43
			24	43	43	54	54	43	43	54	54	54	54	54	54	54	54
		550S162	16	33	33	33	43	33	33	33	43	33	33	33	43	43	43
			24	43	43	43	54	43	43	43	54	43	43	43	54	43	54
126-120	110-115	350S162	16	33	33	43	43	33	33	43	43	43	43	43	43	43	
			24	43	43	54	54	43	43	54	54	54	54	54	54		
		550S162	16	33	33	33	43	33	33	33	43	33	33	33	43	43	
			24	43	43	43	54	43	43	43	54	43	43	43	54	43	
<130 130	115	350S162	16	33	33	43	43	33	33	43	43	43	43	43	43	54	
			24	43	43	54	54	54	54	54	54	54	54	54	54	68	
		550S162	16	33	33	33	43	33	33	33	43	33	33	33	43	43	
			24	43	43	43	54	43	43	43	54	43	43	43	54	43	
—<140	126-120	350S162	16	33	33	43	43	43	43	43	43	43	43	43	43	54	
			24	54	54	54	54	54	54	54	54	54	54	54	68		
		550S162	16	33	33	33	43	33	33	33	43	33	33	33	43	43	
			24	43	43	43	54	43	43	43	54	43	43	43	54	43	
—	<130 130	350S162	16	43	43	43	43	43	43	43	43	43	43	43	54	54	
			24	54	54	54	54	54	54	54	54	54	54	54	68		
		550S162	16	33	33	33	43	33	33	33	43	33	33	33	43	43	
			24	43	43	43	54	43	43	43	54	43	43	43	54	43	

=	< 140	350S162	16	43	43	43	54	43	43	54	54	54	54	54	54
			24	54	54	54	54	54	54	54	54	54	54	54	54
		550S162	16	33	33	33	43	33	33	33	43	33	33	43	43
			24	43	43	43	54	43	43	43	54	43	43	54	54

For SI: 1 inch = 25.4 mm, 1 foot = 304.8 mm, 1 mil = 0.0254 mm, 1 mile per hour = 0.447 m/s, 1 pound per square foot = 0.0479 kPa, 1 ksi = 1,000 psi = 6.895 MPa.

a. Deflection criterion: $L/240$.

b. Design load assumptions:

Second-floor dead load is 10 psf.

Second-floor live load is 30 psf.

Roof/ceiling dead load is 12 psf.

Attic live load is 10 psf.

c. Building width is in the direction of horizontal framing members supported by the wall studs.

d. Minimum Grade 33 ksi steel shall be used for 33 mil and 43 mil thicknesses. Minimum Grade 50 ksi steel shall be used for 54 and 68 mil thicknesses.

TABLE R603.3.2 (11)
40-FOOT-WIDE BUILDING SUPPORTING ONE FLOOR, ROOF AND CEILING^{a, b, c, d}

ULTIMATE WIND SPEED AND EXPOSURE CATEGORY (mph)		MEMBER SIZE	STUD SPACING (inches)	MINIMUM STUD THICKNESS (mils)											
				8-foot Studs				9-foot Studs				10-foot Studs			
				Ground Snow Load (psf)											
Exp. B	Exp. C			20	30	50	70	20	30	50	70	20	30	50	70
115	—	350S162	16	33	33	43	43	33	33	43	43	43	43	43	54
			24	43	43	54	54	43	43	54	54	54	54	54	54
		550S162	16	33	33	33	43	33	33	33	43	33	33	33	43
			24	43	43	54	54	43	43	43	54	43	43	43	54
426-120	410—	350S162	16	33	33	43	43	33	33	43	43	43	43	43	54
			24	43	43	54	54	43	43	54	54	54	54	54	68
		550S162	16	33	33	33	43	33	33	33	43	33	33	33	43
			24	43	43	54	54	43	43	43	54	43	43	43	54
<139 130	115	350S162	16	33-43	33-43	43	43-54	43	43	43	43	43	43	43	54
			24	43-54	43-54	54	54	54	54	54	54	54	54	54	68
		550S162	16	33	33	43	43	33	33	33	43	33	33	33	43
			24	43	43	54	54	43	43	43	54	43	43	43	54
—<140	426-120	350S162	16	43	43	43	54	43	43	43	54	43	43	54	54
			24	54	54	54	54	54	54	54	54	54	54	54	68
		550S162	16	33	33	43	43	33	33	33	43	33	33	43	43
			24	43	43	54	54	43	43	43	54	43	43	54	54
—	<139 130	350S162	16	43	43	43	54	43	43	43	54	54	54	54	54
			24	54	54	54	68	54	54	54	54	54	54	54	68
		550S162	16	33	33	43	43	33	33	33	43	33	33	43	43
			24	43	43	54	54	43	43	43	54	43	43	54	54

=	<140	350S162	16	43	43	43	54	43	43	54	54	54	54	54	
			24	54	54	54	68	54	54	54	68	54	54	68	68
		550S162	16	33	33	43	43	33	33	43	43	33	43	43	43
			24	43	43	54	54	43	43	43	54	43	43	54	54

For SI: 1 inch = 25.4 mm, 1 foot = 304.8 mm, 1 mil = 0.0254 mm, 1 mile per hour = 0.447 m/s, 1 pound per square foot = 0.0479 kPa, 1 ksi = 1,000 psi = 6.895 MPa.

a. Deflection criterion: $L/240$.

b. Design load assumptions:

Second-floor dead load is 10 psf.

Second-floor live load is 30 psf.

Roof/ceiling dead load is 12 psf.

Attic live load is 10 psf.

c. Building width is in the direction of horizontal framing members supported by the wall studs.

d. Minimum Grade 33 ksi steel shall be used for 33 mil and 43 mil thicknesses. Minimum Grade 50 ksi steel shall be used for 54 and 68 mil thicknesses.

TABLE R603.3.2 (12)
24-FOOT-WIDE BUILDING SUPPORTING TWO FLOORS, ROOF AND CEILING^{a, b, c, d}

ULTIMATE WIND SPEED AND EXPOSURE CATEGORY (mph)		MEMBER SIZE	STUD SPACING (inches)	MINIMUM STUD THICKNESS (mils)												
				8-foot Studs				9-foot Studs				10-foot Studs				
				Ground Snow Load (psf)												
Exp. B	Exp. C			20	30	50	70	20	30	50	70	20	30	50	70	
115	—	350S162	16	43	43	43	43	33	33	33	43	43	43	43	43	
			24	54	54	54	54	43	43	54	54	54	54	54	54	
		550S162	16	33	33	43	43	33	33	33	33	33	33	33	33	43
			24	43	43	54	54	43	43	43	43	43	43	43	43	54
426-120	440—	350S162	16	43	43	43	43	33	33	33 43	43	43	43	43	43	
			24	54	54	54	54	54	54	54	54	54	54	54	54	
		550S162	16	33	33	43	43	33	33	33	33	33	33	33	33	43
			24	43	43	54	54	43	43	43	43	43	43	43	43	54
<139 130	115	350S162	16	43	43	43	43	43	43	43	43	43	43	43	43	43-54
			24	54	54	54	54	54	54	54	54	54	54	54	54	54
		550S162	16	33	33	43	43	33	33	33	33	33	33	33	33	43
			24	43	43	54	54	43	43	43	43	43	43	43	43	54
—<140	426-120	350S162	16	43	43	43	43	43	43	43	43	43	43	43	43	54
			24	54	54	54	54	54	54	54	54	54	54	54	54	54
		550S162	16	33	33	43	43	33	33	33	33	33	33	33	33	43
			24	43	43	54	54	43	43	43	43	43	43	43	43	54
—	<139 130	350S162	16	43	43	43	43	43	43	43	43	43	54	54	54	54
			24	54	54	54	54	54	54	54	54	54	54	54	54	68
		550S162	16	33	33	43	43	33	33	33	33	33	33	33	33	43
			24	43	43	54	54	43	43	43	43	43	43	43	43	54
=	<140	350S162	16	43	43	43	43	43	43	54	54	54	54	54	54	

			<u>24</u>	<u>54</u>	<u>54</u>	<u>54</u>	<u>54</u>	<u>54</u>	<u>54</u>	<u>54</u>	<u>54</u>	<u>54</u>	<u>54</u>	<u>68</u>	<u>68</u>
		<u>550S162</u>	<u>16</u>	<u>33</u>	<u>33</u>	<u>43</u>	<u>43</u>	<u>33</u>	<u>33</u>	<u>33</u>	<u>33</u>	<u>33</u>	<u>33</u>	<u>43</u>	<u>43</u>
			<u>24</u>	<u>43</u>	<u>43</u>	<u>54</u>	<u>54</u>	<u>43</u>	<u>43</u>	<u>43</u>	<u>43</u>	<u>43</u>	<u>54</u>	<u>54</u>	<u>54</u>

For SI: 1 inch = 25.4 mm, 1 foot = 304.8 mm, 1 mil = 0.0254 mm, 1 mile per hour = 0.447 m/s, 1 pound per square foot = 0.0479 kPa, 1 ksi = 1,000 psi = 6.895 MPa.

a. Deflection criterion: $L/240$.

b. Design load assumptions:

Top- and middle-floor dead load is 10 psf.

Top-floor live load is 30 psf.

Middle-floor live load is 40 psf.

Roof/ceiling dead load is 12 psf.

Attic live load is 10 psf.

c. Building width is in the direction of horizontal framing members supported by the wall studs.

d. Minimum Grade 33 ksi steel shall be used for 33 mil and 43 mil thicknesses. Minimum Grade 50 ksi steel shall be used for 54 and 68 mil thicknesses.

TABLE R603.3.2 (13)
28-FOOT-WIDE BUILDING SUPPORTING TWO FLOORS, ROOF AND CEILING^{a, b, c, d}

ULTIMATE WIND SPEED AND EXPOSURE CATEGORY (mph)		MEMBER SIZE	STUD SPACING (inches)	MINIMUM STUD THICKNESS (mils)													
				8-foot Studs				9-foot Studs				10-foot Studs					
Exp. B	Exp. C			Ground Snow Load (psf)													
				20	30	50	70	20	30	50	70	20	30	50	70		
115	—	350S162	16	43	43	43	43	43	43	43	43	43	43	43	43	43	
			24	54	54	54	54	54	54	54	54	54	54	54	54	54	
		550S162	16	43	43	43	43	43	43	43	43	43	43	43	43	43	43
			24	54	54	54	54	54	54	54	54	54	54	54	54	54	54
<u>126-120</u>	<u>110</u>	350S162	16	43	43	43	43	43	43	43	43	43	43	43	43	43	
			24	54	54	54	54	54	54	54	54	54	54	54	54		
		550S162	16	43	43	43	43	43	43	43	43	43	43	43	43	43	43
			24	54	54	54	54	54	54	54	54	54	54	54	54	54	54
<u><139</u> <u>130</u>	115	350S162	16	43	43	43	43	43	43	43	43	43	43	43	43 <u>54</u>	43 <u>54</u>	
			24	54	54	54	54	54	54	54	54	54	54	54	<u>54</u>	<u>68</u>	
		550S162	16	43	43	43	43	43	43	43	43	43	43	43	43	43	43
			24	54	54	54	54	54	54	54	54	54	54	54	54	54	54
<u><140</u>	<u>126-120</u>	350S162	16	43	43	43	43	43	43	43	43	43	43 <u>54</u>	43 <u>54</u>	54	54	
			24	54	54	54	54	54	54	54	54	54	54	54	<u>54</u>	<u>68</u>	
		550S162	16	43	43	43	43	43	43	43	43	43	43	43	43	43	43
			24	54	54	54	54	54	54	54	54	54	54	54	54	54	54
—	<u><139</u> <u>130</u>	350S162	16	43	43	43	43	43	43	43	43	43	43-54	54	54	54	54
			24	54	54	54	54	54	54	54	54	54	54	68	68	68	68
		550S162	16	43	43	43	43	43	43	43	43	43	43	43	43	43	43
			24	54	54	54	54	54	54	54	54	54	54	54	54	54	54
=	<u><140</u>	350S162	<u>16</u>	<u>43</u>	<u>43</u>	<u>43</u>	<u>54</u>	<u>54</u>	<u>54</u>	<u>54</u>	<u>54</u>	<u>54</u>	<u>54</u>	<u>54</u>	<u>54</u>	<u>54</u>	
			<u>24</u>	<u>54</u>	<u>54</u>	<u>54</u>	<u>54</u>	<u>54</u>	<u>54</u>	<u>54</u>	<u>54</u>	<u>68</u>	<u>68</u>	<u>68</u>	<u>68</u>	<u>68</u>	

		550S162	<u>16</u>	<u>43</u>	<u>43</u>	<u>43</u>	<u>43</u>	<u>43</u>	<u>43</u>	<u>43</u>	<u>43</u>	<u>43</u>	<u>43</u>	<u>43</u>
			<u>24</u>	<u>54</u>	<u>54</u>	<u>54</u>	<u>54</u>	<u>54</u>	<u>54</u>	<u>54</u>	<u>54</u>	<u>54</u>	<u>54</u>	<u>54</u>

For SI: 1 inch = 25.4 mm, 1 foot = 304.8 mm, 1 mil = 0.0254 mm, 1 mile per hour = 0.447 m/s, 1 pound per square foot = 0.0479 kPa, 1 ksi = 1,000 psi = 6.895 MPa.

- a. Deflection criterion: L/240.
- b. Design load assumptions:
 Top- and middle-floor dead load is 10 psf.
 Top-floor live load is 30 psf.
 Middle-floor live load is 40 psf.
 Roof/ceiling dead load is 12 psf.
 Attic live load is 10 psf.
- c. Building width is in the direction of horizontal framing members supported by the wall studs.
- d. Minimum Grade 33 ksi steel shall be used for 33 mil and 43 mil thicknesses. Minimum Grade 50 ksi steel shall be used for 54 and 68 mil thicknesses.

TABLE R603.3.2 (14)
32-FOOT-WIDE BUILDING SUPPORTING TWO FLOORS, ROOF AND CEILING^{a, b, c, d}

ULTIMATE WIND SPEED AND EXPOSURE CATEGORY (mph)		MEMBER SIZE	STUD SPACING (inches)	MINIMUM STUD THICKNESS (mils)												
				8-foot Studs				9-foot Studs				10-foot Studs				
Exp. B Exp. C				Ground Snow Load (psf)												
				20	30	50	70	20	30	50	70	20	30	50	70	
115	—	350S162	16	43	43	43	54	43	43	43	43	43	43	43	43	43
			24	54	54	54	68	54	54	54	54	54	54	54	54	68
		550S162	16	43	43	43	43	43	43	43	43	43	43	43	43	43
			24	54	54	54	54	54	54	54	54	54	54	54	54	54
<u>426-120</u>	<u>110</u>	350S162	16	43	43	43	54	43	43	43	43	43	43	43	43	54
			24	54	54	54	68	54	54	54	54	54	54	54	68	
		550S162	16	43	43	43	43	43	43	43	43	43	43	43	43	43
			24	54	54	54	54	54	54	54	54	54	54	54	54	54
<u><139</u> <u>130</u>	115	350S162	16	43	43	43	54	43	43	43	43	43 <u>54</u>	43 <u>54</u>	54	54	
			24	54	54	54	68	54	54	54	54	54	54 <u>68</u>	54 <u>68</u>	68	
		550S162	16	43	43	43	43	43	43	43	43	43	43	43	43	43
			24	54	54	54	54	54	54	54	54	54	54	54	54	54
<u>—</u> <u><140</u>	<u>426-120</u>	350S162	16	43	43	43	54	43	43	43	43 <u>54</u>	54	54	54	54	
			24	54	54	54	68	54	54	54	54	68	68	68	68	
		550S162	16	43	43	43	43	43	43	43	43	43	43	43	43	
			24	54	54	54	54	54	54	54	54	54	54	54	54	
—	<u><139</u> <u>130</u>	350S162	16	43	43	43	54	43	43 <u>54</u>	54	54	54	54	54	54	
			24	54	54	54	68	54	54	54	54 <u>68</u>	68	68	68	68	
		550S162	16	43	43	43	43	43	43	43	43	43	43	43	43	
			24	54	54	54	54	54	54	54	54	54	54	54	54	
=	<u><140</u>	350S162	<u>16</u>	<u>43</u>	<u>43</u>	<u>54</u>	<u>54</u>	<u>54</u>	<u>54</u>	<u>54</u>	<u>54</u>	<u>54</u>	<u>54</u>	<u>54</u>	<u>54</u>	
			<u>24</u>	<u>54</u>	<u>54</u>	<u>54</u>	<u>68</u>	<u>54</u>	<u>68</u>	<u>68</u>	<u>68</u>	<u>68</u>	<u>68</u>	<u>68</u>		
		550S162	<u>16</u>	<u>43</u>	<u>43</u>	<u>43</u>	<u>43</u>	<u>43</u>	<u>43</u>	<u>43</u>	<u>43</u>	<u>43</u>	<u>43</u>	<u>43</u>	<u>43</u>	
			<u>24</u>	<u>54</u>	<u>54</u>	<u>54</u>	<u>54</u>	<u>54</u>	<u>54</u>	<u>54</u>	<u>54</u>	<u>54</u>	<u>54</u>	<u>54</u>	<u>54</u>	

For SI: 1 inch = 25.4 mm, 1 foot = 304.8 mm, 1 mil = 0.0254 mm, 1 mile per hour = 0.447 m/s, 1 pound per square foot = 0.0479 kPa, 1 ksi = 1,000 psi = 6.895 MPa.

a. Deflection criterion: $L/240$.

b. Design load assumptions:

Top- and middle-floor dead load is 10 psf.

Top-floor live load is 30 psf.

Middle-floor live load is 40 psf.

Roof/ceiling dead load is 12 psf.

Attic live load is 10 psf.

c. Building width is in the direction of horizontal framing members supported by the wall studs.

d. Minimum Grade 33 ksi steel shall be used for 33 mil and 43 mil thicknesses. Minimum Grade 50 ksi steel shall be used for 54 and 68 mil thicknesses.

TABLE R603.3.2 (15)
36-FOOT-WIDE BUILDING SUPPORTING TWO FLOORS, ROOF AND CEILING^{a, b, c, d}

ULTIMATE WIND SPEED AND EXPOSURE CATEGORY (mph)		MEMBER SIZE	STUD SPACING (inches)	MINIMUM STUD THICKNESS (mils)														
				8-foot Studs				9-foot Studs				10-foot Studs						
Exp. B	Exp. C			Ground Snow Load (psf)														
				20	30	50	70	20	30	50	70	20	30	50	70			
115	—	350S162	16	54	54	54	54	43	43	43	54	54	54	54	54	54	54	
			24	68	68	68	68	54	54	54	68	68	68	68	68	68	68	
		550S162	16	43	43	43	54	43	43	43	43	43	43	43	43	43	43	43
			24	54	54	54	54	54	54	54	54	54	54	54	54	54	54	54
126-120	140-144	350S162	16	54	54	54	54	43	43	43	54	54	54	54	54	54	54	
			24	68	68	68	68	54	54	54	68	68	68	68	68	68		
		550S162	16	43	43	43	54	43	43	43	43	43	43	43	43	43	43	
			24	54	54	54	54	54	54	54	54	54	54	54	54	54	54	
130	115	350S162	16	54	54	54	54	43	43	43	54	54	54	54	54	54	54	
			24	68	68	68	68	54	54	54	68	68	68	68	68	68		
		550S162	16	43	43	43	54	43	43	43	43	43	43	43	43	43	43	
			24	54	54	54	54	54	54	54	54	54	54	54	54	54	54	
140	126-120	350S162	16	54	54	54	54	43	43	43	54	54	54	54	54	54	54	
			24	68	68	68	68	54	54	54	68	68	68	68	68	68		
		550S162	16	43	43	43	54	43	43	43	43	43	43	43	43	43	43	
			24	54	54	54	54	54	54	54	54	54	54	54	54	54	54	
—	130	350S162	16	54	54	54	54	54	54	54	54	54	54	54	54	54	54	
			24	68	68	68	68	54	54	68	68	68	68	68	68	68		
		550S162	16	43	43	43	54	43	43	43	43	43	43	43	43	43	43	
			24	54	54	54	54	54	54	54	54	54	54	54	54	54	54	
=	140	350S162	16	54	54	54	54	54	54	54	54	54	54	54	54	54	54	
			24	68	68	68	68	68	68	68	68	68	68	68	68	68		
		550S162	16	43	43	43	54	43	43	43	43	43	43	43	43	43	43	
			24	54	54	54	54	54	54	54	54	54	54	54	54	54	54	

For SI: 1 inch = 25.4 mm, 1 foot = 304.8 mm, 1 mil = 0.0254 mm, 1 mile per hour = 0.447 m/s, 1 pound per square foot = 0.0479 kPa, 1 ksi = 1,000 psi = 6.895 MPa.

a. Deflection criterion: $L/240$.

b. Design load assumptions:

Top- and middle-floor dead load is 10 psf.

Top-floor live load is 30 psf.

Middle-floor live load is 40 psf.

Roof/ceiling dead load is 12 psf.

Attic live load is 10 psf.

c. Building width is in the direction of horizontal framing members supported by the wall studs.

d. Minimum Grade 33 ksi steel shall be used for 33 mil and 43 mil thicknesses. Minimum Grade 50 ksi steel shall be used for 54 and 68 mil thicknesses.

TABLE R603.3.2 (16)
40-FOOT-WIDE BUILDING SUPPORTING TWO FLOORS, ROOF AND CEILING^{a, b, c, d}

ULTIMATE WIND SPEED AND EXPOSURE CATEGORY (mph)		MEMBER SIZE	STUD SPACING (inches)	MINIMUM STUD THICKNESS (mils)													
				8-foot Studs				9-foot Studs				10-foot Studs					
Exp. B	Exp. C			Ground Snow Load (psf)													
				20	30	50	70	20	30	50	70	20	30	50	70		
115	—	350S162	16	54	54	54	54	54	54	54	54	54	54	54	54	54	54
			24	68	68	68	68	68	68	68	68	68	68	68	68	68	68
		550S162	16	54	54	54	54	43	43	54	54	43	43	54	54	54	54
			24	54	54	54	68	54	54	54	54	54	54	54	54	54	54
426120	440—	350S162	16	54	54	54	54	54	54	54	54	54	54	54	54	54	54
			24	68	68	68	68	68	68	68	68	68	68	68	68	68	
		550S162	16	54	54	54	54	43	43	54	54	43	43	54	54	54	54
			24	54	54	54	68	54	54	54	54	54	54	54	54	54	54
<139130	115	350S162	16	54	54	54	54	54	54	54	54	54	54	54	54	54	54
			24	68	68	68	68	68	68	68	68	68	68	68	68	68	
		550S162	16	54	54	54	54	43	43	54	54	43	43	54	54	54	54
			24	54	54	54	68	54	54	54	54	54	54	54	54	54	54
—<140	426120	350S162	16	54	54	54	54	54	54	54	54	54	54	54	54	54	54
			24	68	68	68	68	68	68	68	68	68	68	68	68	68	
		550S162	16	54	54	54	54	43	43	54	54	43	43	54	54	54	54
			24	54	54	54	68	54	54	54	54	54	54	54	54	54	54
—	<139130	350S162	16	54	54	54	54	54	54	54	54	54	54	54	54	54	54
			24	68	68	68	68	68	68	68	68	68	68	68	68	68	
		550S162	16	54	54	54	54	43	43	54	54	43	43	54	54	54	54
			24	54	54	54	68	54	54	54	54	54	54	54	54	54	54
=	<140	350S162	16	54	54	54	54	54	54	54	54	54	54	54	54	54	54
			24	68	68	68	68	68	68	68	68	68	68	68	68	97	
		550S162	16	54	54	54	54	43	43	54	54	43	43	54	54	54	54
			24	54	54	54	68	54	54	54	54	54	54	54	54	54	54

For SI: 1 inch = 25.4 mm, 1 foot = 304.8 mm, 1 mil = 0.0254 mm, 1 mile per hour = 0.447 m/s, 1 pound per square foot = 0.0479 kPa, 1 ksi = 1,000 psi = 6.895 MPa.

a. Deflection criterion: $L/240$.

b. Design load assumptions:

Top and middle floor dead load is 10 psf.

Top floor live load is 30 psf.

Middle floor live load is 40 psf.

Roof/ceiling dead load is 12 psf.

Attic live load is 10 psf.

c. Building width is in the direction of horizontal framing members supported by the wall studs.

d. Minimum Grade 33 ksi steel shall be used for 33 mil and 43 mil thicknesses. Minimum Grade 50 ksi steel shall be used for 54 and 68 mil thicknesses.

TABLE R603.3.2.1 (1)
ALL BUILDING WIDTHS GABLE ENDWALLS 8, 9 OR 10 FEET IN HEIGHT^{a, b, c, d}

ULTIMATE WIND SPEED AND EXPOSURE CATEGORY (mph)		MEMBER SIZE	STUD SPACING (inches)	MINIMUM STUD THICKNESS (mils)		
				8-foot Studs	9-foot Studs	10-foot Studs
Exp. B	Exp. C					
115	—	350S162	16	33	33	33
			24	33	33	33
		550S162	16	33	33	33
			24	33	33	33
<u>426</u> <u>120</u>	<u>440</u> <u>—</u>	350S162	16	33	33	33
			24	33	33	43
		550S162	16	33	33	33
			24	33	33	33
<u><139</u> <u>130</u>	115	350S162	16	33	33	33
			24	33	33 <u>43</u>	43
		550S162	16	33	33	33
			24	33	33	33
<u>—</u> <u><140</u>	<u>426</u> <u>120</u>	350S162	16	33	33	33 <u>43</u>
			24	43 <u>33</u>	43	54
		550S162	16	33	33	33
			24	33	33	43 <u>33</u>
—	<u><139</u> <u>130</u>	350S162	16	33	43 <u>33</u>	43
			24	43	54 <u>43</u>	54
		550S162	16	33	33	33
			24	33	33 <u>43</u>	43
=	<u><140</u>	<u>350S162</u>	<u>16</u>	<u>33</u>	<u>43</u>	<u>43</u>
			<u>24</u>	<u>43</u>	<u>54</u>	<u>54</u>
		<u>550S162</u>	<u>16</u>	<u>33</u>	<u>33</u>	<u>33</u>
			<u>24</u>	<u>43</u>	<u>43</u>	<u>43</u>

For SI: 1 inch = 25.4 mm, 1 foot = 304.8 mm, 1 mil = 0.0254 mm, 1 mile per hour = 0.447 m/s, 1 pound per square foot = 0.0479 kPa, 1 ksi = 1,000 psi = 6.895 MPa.

a. Deflection criterion $L/240$.

b. Design load assumptions:

Ground snow load is 70 psf.

Roof/ceiling dead load is 12 psf.

Floor dead load is 10 psf.

Floor live load is 40 psf.

Attic dead load is 10 psf.

c. Building width is in the direction of horizontal framing members supported by the wall studs.

d. Minimum Grade 33 ksi steel shall be used for 33 mil and 43 mil thicknesses. Minimum Grade 50 ksi steel shall be used for 54 and 68 mil thicknesses.

TABLE R603.3.2.1 (2)
ALL BUILDING WIDTHS GABLE ENDWALLS OVER 10 FEET IN HEIGHT^{a, b, c, d}

ULTIMATE WIND SPEED AND EXPOSURE CATEGORY (mph)		MEMBER SIZE	STUD SPACING (inches)	MINIMUM STUD THICKNESS (mils)					
				Stud Height, h (feet)					
Exp. B	Exp. C			10 $h \leq 12$	12 $h \leq 14$	14 $h \leq 16$	16 $h \leq 18$	18 $h \leq 20$	20 $h \leq 22$
115	—	350S162	16	33	43	68	97	—	—
			24	43	68	—	—	—	—
		550S162	16	33	33	33	43	<u>54</u> <u>43</u>	54
			24	33	33 <u>43</u>	43	54	68	97
<u>126-120</u>	<u>110</u> —	350S162	16	43	54	97	—	—	—
			24	54	97	—	—	—	—
		550S162	16	33	33	43	<u>54</u> <u>43</u>	54	68
			24	33	43	54	54	68	97
139-130	115	350S162	16	43	68 <u>54</u>	97	—	—	—
			24	68 <u>54</u>	97	—	—	—	—
		550S162	16	33	43 <u>33</u>	43	54	68 <u>54</u>	97
			24	43	<u>54</u> <u>43</u>	54	68	97	97
140	<u>126-120</u>	350S162	16	<u>54</u> <u>43</u>	68	—	—	—	—
			24	68	—	—	—	—	—
		550S162	16	33	43	<u>54</u> <u>43</u>	54	68	97
			24	43	54	54	68	97	—
—	139-130	350S162	16	54	97	—	—	—	—
			24	97	—	—	—	—	—
		550S162	16	43 <u>33</u>	<u>54</u> <u>43</u>	54	68	97	—
			24	<u>54</u> <u>43</u>	54	68 <u>54</u>	97	—	—
=	<u>140</u>	<u>350S162</u>	<u>16</u>	<u>54</u>	<u>97</u>	=	=	=	=
			<u>24</u>	<u>97</u>	=	=	=	=	=
		<u>550S162</u>	<u>16</u>	<u>43</u>	<u>43</u>	<u>54</u>	<u>97</u>	<u>97</u>	=
			<u>24</u>	<u>54</u>	<u>54</u>	<u>68</u>	=	=	=

For SI: 1 inch = 25.4 mm, 1 foot = 304.8 mm, 1 mil = 0.0254 mm, 1 mile per hour = 0.447 m/s, 1 pound per square foot = 0.0479 kPa, 1 ksi = 1,000 psi = 6.895 MPa.

a. Deflection criterion $L/240$.

b. Design load assumptions:

Ground snow load is 70 psf.

Roof/ceiling dead load is 12 psf.

Floor dead load is 10 psf.

Floor live load is 40 psf.

Attic dead load is 10 psf.

c. Building width is in the direction of horizontal framing members supported by the wall studs.

d. Minimum Grade 33 ksi steel shall be used for 33 mil and 43 mil thicknesses. Minimum Grade 50 ksi steel shall be used for 54 and 68 mil thicknesses.

R603.3.5 Splicing. Steel studs and other structural members shall not be spliced without approved design. Tracks shall be spliced in accordance with Figure R603.3.5.

R603.6 Headers. Headers shall be installed above all wall openings in exterior walls and interior load-bearing walls. Box beam headers and back-to-back headers each shall be formed from two equal sized

C-shaped members in accordance with Figures R603.6(1) and R603.6(2), respectively, and Tables R603.6(1) through R603.6(6). L-shaped headers shall be permitted to be constructed in accordance with AISI S230. Alternately, headers shall be permitted to be designed and constructed in accordance with AISI S400, Section D4-S240.

TABLE R603.7 (2)
HEADER TO KING STUD CONNECTION REQUIREMENTS^{a, b, c, d}

HEADER SPAN (feet)	ULTIMATE WIND SPEED (mph), EXPOSURE CATEGORY					
	115 B	120 B	130 B	<140 B	130 C	<140 C
			115 C	120 C		
≤ 4'	4-No. 8 screws	4-No. 8 screws	4-No. 8 screws	4-No. 8 screws	6-No. 8 screws	6-No. 8 screws
> 4" to 8"	4-No. 8 screws	4-No. 8 screws	4-No. 8 screws	6-No. 8 screws	8-No. 8 screws	8-No. 8 screws
> 8" to 12"	4-No. 8 screws	6-No. 8 screws	6-No. 8 screws	8-No. 8 screws	10-No. 8 screws	12-No. 8 screws
> 12" to 16"	4-No. 8 screws	6-No. 8 screws	8-No. 8 screws	10-No. 8 screws	12-No. 8 screws	14-No. 8 screws

For SI: 1 inch = 25.4 mm, 1 foot = 304.8 mm, 1 mile per hour = 0.447 m/s, 1 pound = 4.448 N.

- All screw sizes shown are minimum.
- For headers located on the first floor of a two-story building or the first or second floor of a three-story building, the total number of screws is permitted to be reduced by 2 screws, but the total number of screws shall not be less than four.
- For roof slopes of 6:12 or greater, the required number of screws shall be permitted to be reduced by half, but the total number of screws shall not be less than four.
- Screws can be replaced by an uplift connector that has a capacity of the number of screws multiplied by 164 pounds.

R603.9.4.1 Ultimate design wind speeds greater than 126-130 mph. Where ultimate design wind speeds exceed 126-130 miles per hour (56-58 m/s), Exposure Category C walls shall be provided with direct uplift connections in accordance with AISI S230, Section E13.3, and AISI S230, Section F7.2-F8.2, as required for 139-140 miles per hour (62-63 m/s), Exposure Category C.

TABLE R603.8
HEAD AND SILL TRACK SPAN

ULTIMATE WIND SPEED AND EXPOSURE CATEGORY (mph)		ALLOWABLE HEAD AND SILL TRACK SPAN^{a, b, c} (feet-inches)					
		TRACK DESIGNATION^d					
B	C	350T125-33	350T125-43	350T125-54	550T125-33	550T125-43	550T125-54
115	—	4'-10" 5'-9"	5'-5" 6'-9"	6'-0" 9'-3"	5'-8" 7'-3"	6'-3" 9'-1"	6'-10" 12'-5"
126-120	110	4'-6" 5'-6"	5'-1" 6'-6"	5'-8" 8'-11"	5'-4" 7'-0"	5'-11" 8'-9"	6'-5" 11'-11"
<139-130	115	4'-2" 4'-10"	4'-9" 5'-9"	5'-4" 7'-10"	5'-1" 6'-2"	5'-7" 7'-8"	6'-1" 10'-6"
—<140	126-120	3'-11" 4'-8"	4'-6" 5'-6"	5'-0" 7'-6"	4'-10" 5'-11"	5'-4" 7'-4"	5'-10" 10'-1"
—	<139-130	3'-8" 4'-3"	4'-2" 5'-1"	4'-9" 6'-11"	4'-1" 5'-6"	5'-1" 6'-9"	5'-7" 9'-4"
—	≤ 140	4'-0"	4'-9"	6'-5"	5'-1"	6'-4"	8'-8"

For SI: 1 inch = 25.4 mm, 1 foot = 304.8 mm, 1 mile per hour = 0.447 m/s.

- Deflection limit: $L/240$.
- Head and sill track spans are based on components and cladding wind pressures and 48-inch tributary span.
- For openings less than 4 feet in height that have both a head track and sill track, the spans are permitted to be multiplied by 1.75. For openings less than or equal to 6 feet in height that have both a head track and a sill track, the spans are permitted to be multiplied by a factor of 1.5.
- Minimum Grade 33 ksi steel shall be used for 33 mil and 43 mil thicknesses. Minimum Grade 50 ksi steel shall be used for 54 and 68 mil thicknesses.

TABLE R603.9.2 (1)
MINIMUM PERCENTAGE OF FULL-HEIGHT STRUCTURAL SHEATHING ON EXTERIOR WALLS^{a, b}

WALL SUPPORTING	ROOF SLOPE	ULTIMATE WIND SPEED AND EXPOSURE (mph)					
		115 B	126 120 B	130 B	<140 B	<139	<140
			110 C	115 C	126 120 C	130 C	C
Roof and ceiling only (one story or top floor of two- or three-story building).	3:12	9	119	1142	1346	1720	20
	6:12	13	15	1720	2226	2835	35
	9:12	23	2725	2930	3350	5358	59
	12:12	3233	3935	40	4466	7075	76
One story, roof and ceiling (first floor of a two-story building or second floor of a three-story building).	3:12	2627	3230	3435	3950	5366	67
	6:12	2728	3330	3440	4458	6174	75
	9:12	38	4540	4655	6174	7894	92
	12:12	4345	5350	5765	72400	106445	116
Two stories, roof and ceiling (first floor of a three-story building).	3:12	4345	5354	5758	6484	89442	113
	6:12	4143	5145	5160	6790	95443	114
	9:12	53	6355	6380	8998	104124	126
	12:12	5457	6765	7490	100434	142455	157

For SI: 1 mph = 0.447 m/s.

a. Linear interpolation is permitted.

b. For hip-roofed homes the minimum percentage of full-height sheathing, based upon wind, is permitted to be multiplied by a factor of 0.95 for roof slopes not exceeding 7:12 and a factor of 0.9 for roof slopes greater than 7:12.

Reference standards type: This reference standard is new to the ICC Code Books
Add new standard(s) as follows:

AISI S240-15, North American Standard for Cold-Formed Steel Structural Framing (2015)

Standards are available for free download at www.aisistandards.org

Reason: This proposal is one in a series intended to update the content of the Cold-Formed Steel (CFS) light-framed construction provisions of the IRC. The proposed revisions align the IRC with the provisions of *AISI S230-15, Standard for Cold-Formed Steel Framing - Prescriptive Method for One- and Two-Family Dwellings*. The wind loads are adjusted to conform to the provisions of the ASCE7-10 Directional Method, and the wind speed increments are modified to correlate with the increments as shown in the wind speed maps (Figures R301.2(4)A and B). Member size and connection requirement tables are modified to correspond to the adjusted wind loads per methods specified in AISI S240 and AISI S100; respectively. Minor corrections have also been made to the text where applicable. Further explanation for each section follows:

Applicability Limits - This proposal adjusts the upper limit of the ultimate design wind speed from less than 139 miles per hour (mph) to less than 140 mph. The previous upper limit was based on a conversion of the wind speed from a nominal speed to an ultimate speed. For which, the conversion of the 110 mph nominal wind speed resulted in a rounded value of 139 mph ultimate wind speed upper limit (ie. less than 139 mph). This is detailed in the last cycle code change proposal RB258-13. Since the wind speeds now listed in this section are actual ultimate wind speeds, as derived from the ultimate wind speed maps, this section is now applicable for ultimate wind speeds up to 140 mph.

Tables R603.3.1 and R603.3.1.1(1) - Connection requirements are modified to accommodate corresponding wind load adjustments as previously stated.

Table R603.3.1.1(2) - Anchor spacing requirements are modified to accommodate corresponding wind load adjustments as previously stated.

Table R603.3.1.2(2) through Table R603.3.1.2(16) - Minimum stud thickness requirements are modified to accommodate corresponding wind load adjustments as previously stated.

Table R603.3.2.1(1) and Table R603.3.2.1(2) - Minimum stud thickness requirements are modified to accommodate corresponding wind load adjustments as previously stated.

Section R603.3.5 Splicing - Steel studs are permitted to be spliced with approved design per AISI S230.

Section R603.6 Headers - Previously this section referenced AISI S100, Section D4 for header design provisions. Section D4 of AISI S100 directed the user to *AISI S212 - North American Standard for Cold-Formed Steel Framing - Header Design*. However, the new standard **AISI S240**, *North American Standard for Cold-Formed Steel Structural Framing*, addresses requirements for construction with cold-formed steel structural framing that are common to prescriptive and engineered light frame construction. This comprehensive standard was formed by merging the following AISI standards:

- AISI S200, *North American Standard for Cold-Formed Steel Framing-General Provisions*
- AISI S210, *North American Standard for Cold-Formed Steel Framing-Floor and Roof System Design*
- AISI S211, *North American Standard for Cold-Formed Steel Framing-Wall Stud Design*
- AISI S212, *North American Standard for Cold-Formed Steel Framing-Header Design*
- AISI S213, *North American Standard for Cold-Formed Steel Framing-Lateral Design*
- AISI S214, *North American Standard for Cold-Formed Steel Framing-Truss Design*

Consequently, AISI S240 supersedes all previous editions of the above mentioned individual AISI standards and is the correct reference for this application.

Table R603.8 - Head and sill track allowable spans are modified to accommodate corresponding wind load adjustments as previously stated.

Table R603.9.2(1) - Minimum required percentages for full height sheathing are modified to accommodate corresponding wind load adjustments as previously stated.

The AISI Standards are available for free download at www.aisistandards.org

Cost Impact: Will increase the cost of construction

The proposed changes to this section will not increase the cost of construction in general. While the overwhelming majority of the prescribed members have not changed or are reduced in size, there may be conditions for which the minimum member size will increase.

Analysis: A review of the standard(s) proposed for inclusion in the code, AISI 240-15, with regard to the ICC criteria for referenced standards (Section 3.6 of CP#28) will be posted on the ICC website on or before April 1, 2016.

Report of Committee Action Hearings
--

Committee Action:

Approved as Submitted

Committee Reason: This change aligns the cold-formed steel wall framing provisions with the new referenced cold-formed steel structural framing standard.

Also, the applicable design wind speed is changed to less than 140 mph ultimate. The framing tables are revised to reflect the wind load increase and to align with ASCE 7-10. Directional Method.

Assembly Action:

None

Final Action Results

RB248-16

AS

[←BACK](#)

Code Change No: **RB249-16**

Original Proposal

Section: R606.1

Proponent: Jason Thompson, Masonry Alliance for Codes and Standards (MACS), representing Masonry Alliance for Codes and Standards (jthompson@ncma.org); Phillip Samblanet, representing The Masonry Society (psamblanet@masonrysociety.org)

Revise as follows:

R606.1 General. Masonry construction shall be designed and constructed in accordance with the provisions of this section, TMS 402, TMS 403, or ~~in accordance with the provisions of TMS 402/ ACI 530/ASCE 5-404.~~

Reference standards type: This reference standard is new to the ICC Code Books
Add new standard(s) as follows:

TMS 404-16 – Standard for the Design of Architectural Cast Stone

Reason: Architectural cast stone is a non-structural masonry system typically used as architectural accents such as balusters, quoins, sills, etc. While generally covered within the masonry requirements of the IRC, the vast majority of design, fabrication, and installation guidance for these systems has historically stemmed from industry-generated best practices; a gap now filled with the creation of these three new standards.

Topics covered collectively under these three new standards include:

- 1) Minimum requirements for reinforcement, ties, and anchors used with cast stone along with the associated corrosion protection requirements for these materials.
- 2) Additional requirements for cast stone materials not covered within ASTM C1364.
- 3) Tolerance requirements for individual cast stone elements as well as finished assemblies.
- 4) Information to be included in shop drawings and submittal packages.
- 5) Ancillary materials used during the installation of cast stone including mortar, grout, and jointing materials.
- 6) Minimum quality assurance requirements including testing frequency, sample panels, and inspection.
- 7) Installation criteria for both wet-setting (laying cast stone elements in mortar) as well as dry-setting (where cast stone units are shimmed and caulked).

Cost Impact: Will not increase the cost of construction

The addition of these news standards is an alternative to the existing IRC provisions based on existing industry best practices.

Report of Committee Action Hearings

Committee Action:

Approved as Submitted

Committee Reason: This proposal brings the current standard for design and installation of architectural cast stone into the IRC..

Assembly Action:

None

Final Action Results

RB249-16

AS

Code Change No: RB243-16

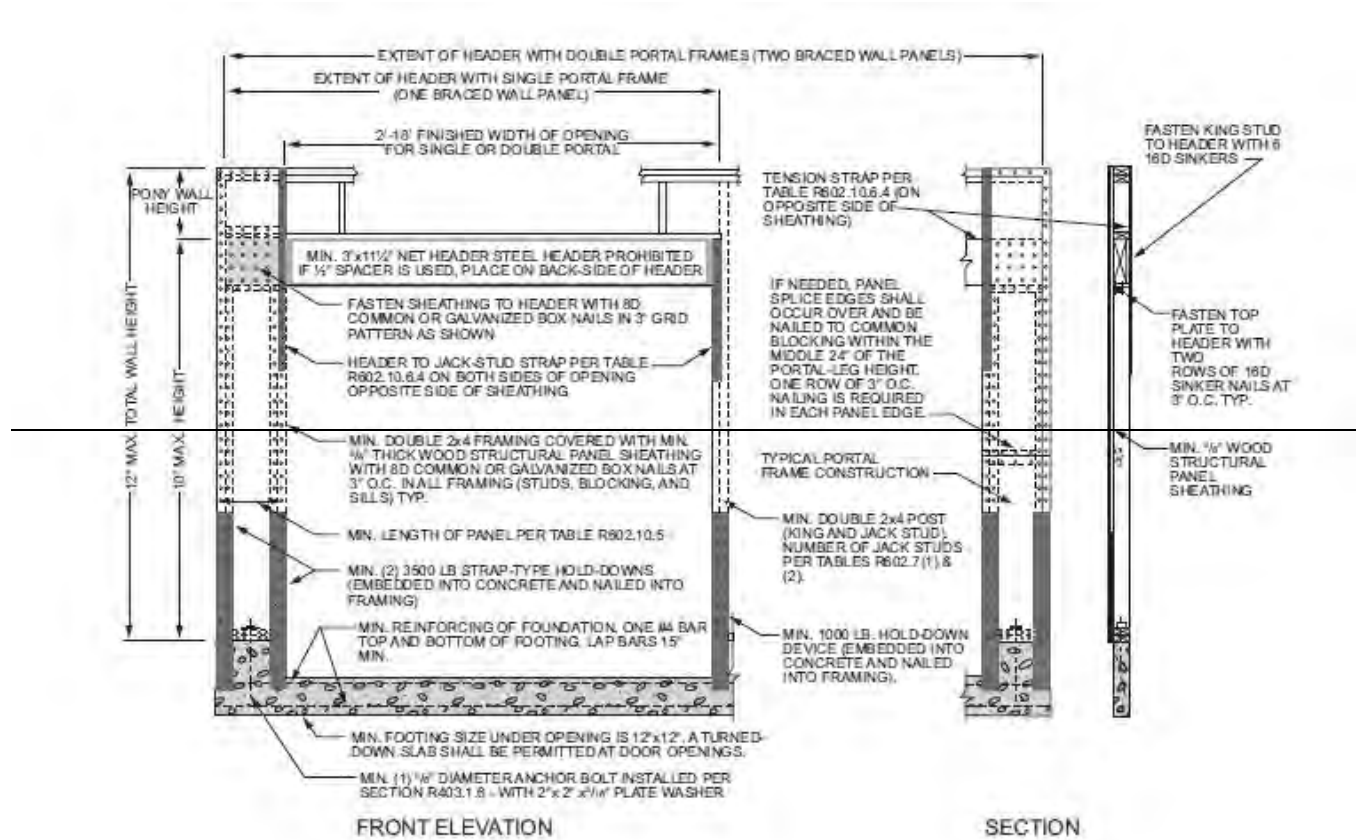
Original Proposal

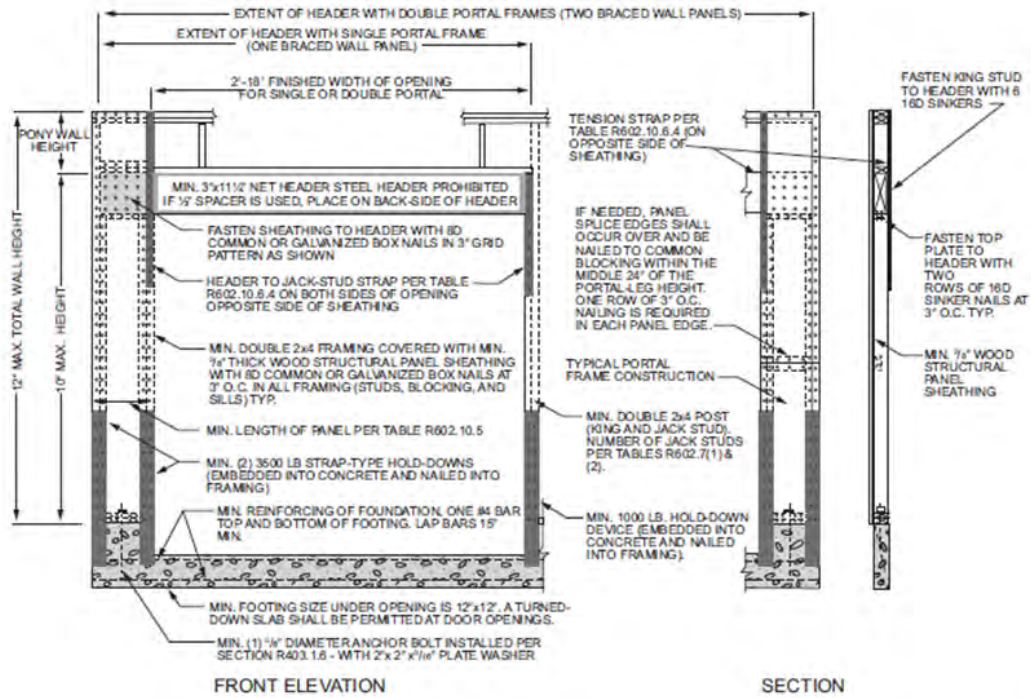
Section: R602.10.6.2

Proponent: Edward Keith, representing APA- The Engineered Wood Association (ed.keith@apawood.org)

Revise as follows:

**FIGURE R602.10.6.2
METHOD PFH—PORTAL FRAME WITH HOLD-DOWNS**





Note: Nailing of sheathing behind the 3500-lb strap shall not be required.

For SI: 1 inch = 25.4 mm, 1 foot = 304.8 mm.

FIGURE R602.10.6.2
METHOD PFH PORTAL FRAME WITH HOLD-DOWNS

For SI: 1 inch = 25.4 mm, 1 foot = 304.8 mm.

Reason: The required nailing on the 3500 lb strap provides sufficient anchorage for the wood structural panel to framing connection while prevent the potential for splitting of the framing while anchoring the strap. It also prevents the sheathing-to-framing nailing from interfering with the required strap nailing. In addition it saves time and money for the builder without compromising the effectiveness of the portal.

Cost Impact: Will not increase the cost of construction
 This change proposal will not increase the cost of construction and may save the builder a little time and money during construction without impacting the performance of the structure.

Report of Committee Action Hearings

Committee Action:

Approved as Submitted

Committee Reason: This proposal clarifies that nailing behind the strap is not required and based on the proponents published reason statement.

Assembly Action:

None

Final Action Results

RB243-16

AS

Code Change No: **RB245-16**

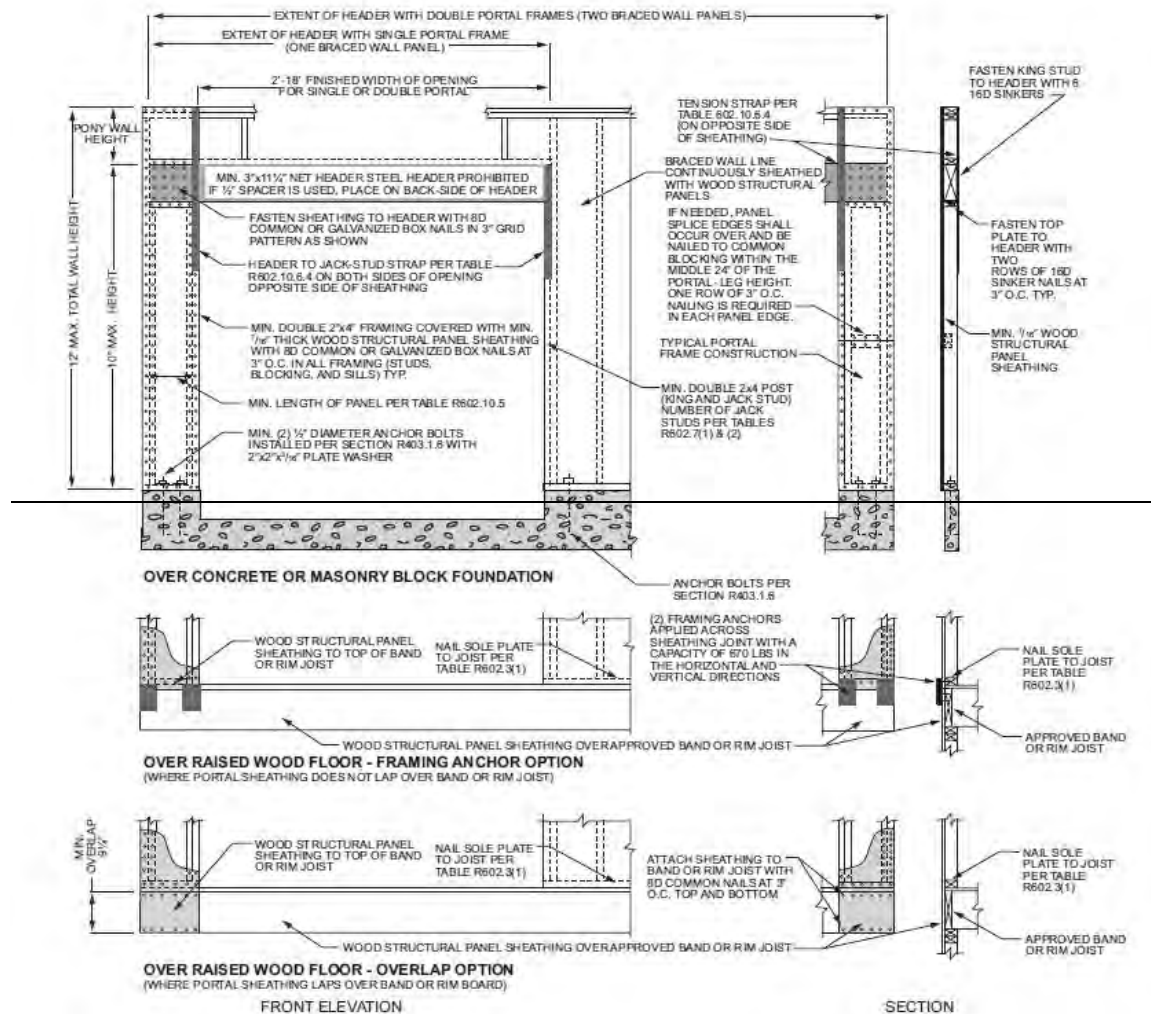
Original Proposal

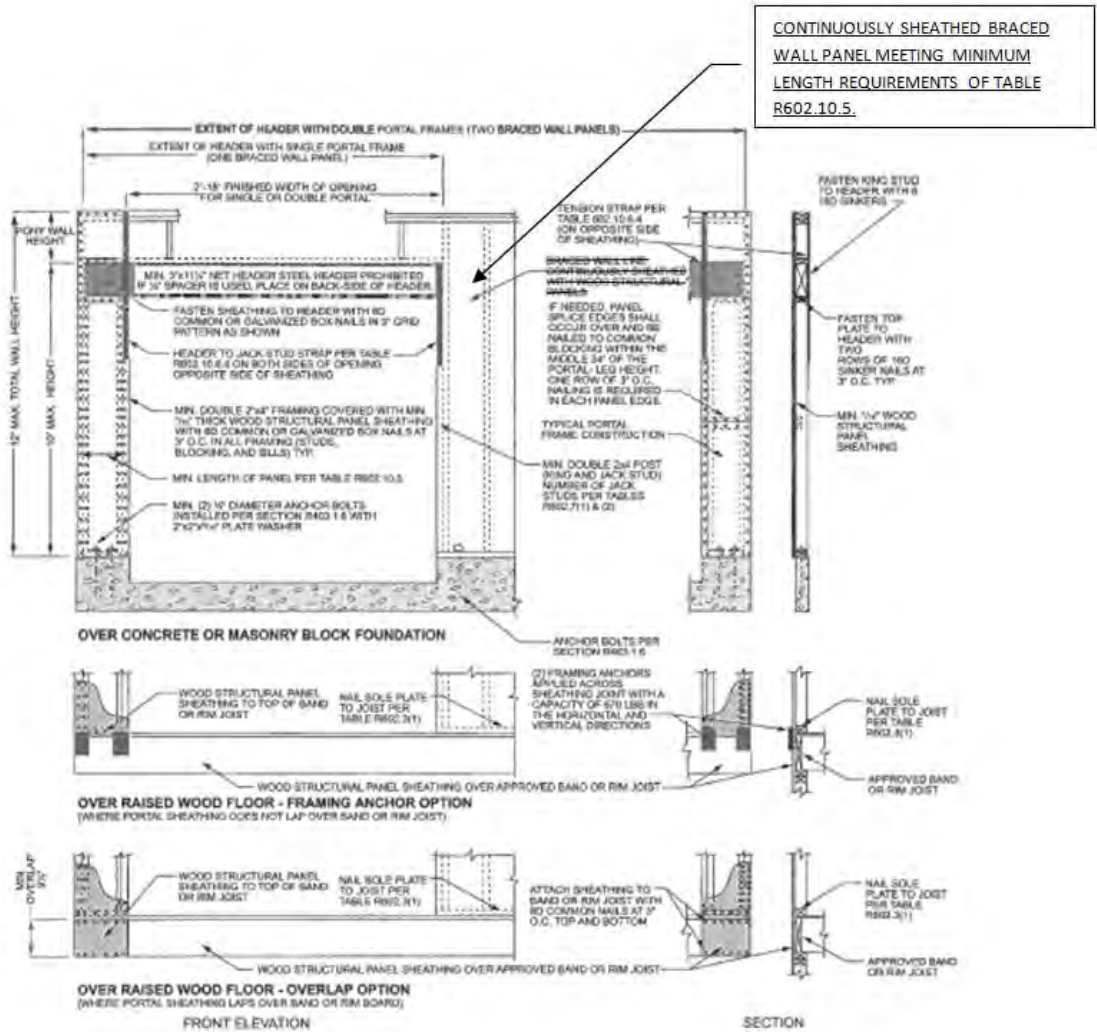
Section: R602.10.6.4

Proponent: Edward Keith, representing APA- The Engineered Wood Association (ed.keith@apawood.org)

Revise as follows:

FIGURE R602.10.6.4
METHOD CS-PF—CONTINUOUSLY SHEATHED PORTAL FRAME PANEL CONSTRUCTION





CONTINUOUSLY SHEATHED BRACED WALL PANEL MEETING MINIMUM LENGTH REQUIREMENTS OF TABLE R602.10.5.

For SI: 1 inch = 25.4 mm, 1 foot = 304.8 mm.

Reason: The proposed code change more clearly states the intent of the original language. It is important that the wall element away from the single portal be well anchored to obviate the need for the anchor strap at the base of the post-end of the single-portal. This anchorage is provided by the presence of a continuously sheathed braced wall panel meeting the minimum length requirements of Table R602.10.5. The way the current figure treats the post-end sheathing requirement, any element of a continuously sheathed braced wall line, regardless of length, could be used. Even an element less than the minimum length requirements listed in Table R602.10.5 would be permitted even though such an element would not provide the necessary anchorage. This proposal modifies the language to more clearly represent the intent of the provision.

Cost Impact: Will not increase the cost of construction
 This change will not increase the cost of construction as it clarifies the original intent of the code provision.

Report of Committee Action Hearings

Committee Action:

Approved as Submitted

Committee Reason: This change clarifies the need that a minimum length panel as proscribed in Table R602.10.5 is required on the side opposite the single portal.

Assembly Action:

None

Final Action Results

RB245-16

AS

[←BACK](#)

Code Change No: **RB254-16**

Original Proposal

Section: R609.2

Proponent: Jeff Inks, representing Window & Door Manufacturers Association (jinks@wdma.com)

Revise as follow:

R609.2 Performance. Exterior windows and doors shall be ~~designed to resist~~ capable of resisting the design wind loads specified in Table R301.2(2) adjusted for height and exposure in accordance with Table R301.2(3) or determined in accordance with ASCE 7 ~~using the allowable stress.~~ For exterior windows and doors tested in accordance with Sections R609.3 and R609.5, required design load combinations of wind pressures determined from ASCE 7 ~~are permitted to be multiplied by 0.6.~~ Design wind loads for exterior glazing not part of a labeled assembly shall be permitted to be determined in accordance with Chapter 24 of the *International Building Code*.

Reason: This proposal is intended to clarify that the use of the 0.6 conversion multiplier is allowed with respect to the determination of design wind pressures in accordance with ASCE 7 and testing of the respective assemblies in accordance with Section R609.3 or R609.5 accordingly. While that is what the existing provision allows, as currently written, that is not entirely clear and has led to confusion regarding wind load requirements. This proposed amendment expressly states that the use of 0.6 multiplier is allowed and will alleviate the confusion that currently exists benefiting all – code officials, manufacturers and builders.

Cost Impact: Will not increase the cost of construction
This is a clarification. No substantive change.

Report of Committee Action Hearings

Committee Action:

Approved as Modified

Modify as follows:

R609.2 Performance. Exterior windows and doors shall be capable of resisting the design wind loads specified in Table R301.2(2) adjusted for height and exposure in accordance with Table R301.2(3) or determined in accordance with ASCE 7 . For exterior windows and doors tested in accordance with Sections R609.3 and R609.5, required design wind pressures determined from ASCE 7 using the ultimate strength design (USD) are permitted to be multiplied by 0.6. Design wind loads for exterior glazing not part of a labeled assembly shall be permitted to be determined in accordance with Chapter 24 of the *International Building Code*.

Committee Reason: The committee approved this proposal based on the proponents published reason statement. The windows and doors are being tested to allowable stress design and the 0.6 is the appropriate multiplier to apply to the ultimate strength design. The modification clarifies where the 0.6 multiplier is to be applied.

Assembly Action

None

Final Action Results

RB254-16

AM

Code Change No: **RB259-16**

Original Proposal

Section: R202 (New), R609.6, R609.6.1, R609.6.2 (New)

Proponent: T. Eric Stafford, PE, representing Institute for Business and Home Safety

Add new definition as follows:

Impact Protective System Construction that has been shown by testing to withstand the impact of test missiles and that is applied, attached, or locked over exterior glazing.

Revise as follows:

R609.6 Wind-borne debris protection. Protection of exterior windows ~~and~~ glass doors, ~~and~~ doors with glass in buildings located in wind-borne debris regions shall be in accordance with Section R301.2.1.2.

R609.6.1 Fenestration testing and labeling. Fenestration shall be tested by an *approved* independent laboratory, listed by an *approved* entity, and bear a *label* identifying manufacturer, performance characteristics, and *approved* inspection agency to indicate compliance with the requirements of the following specification(s):

1. ASTM E 1886 and ASTM E 1996; or
2. AAMA 506.

Add new text as follows:

R609.6.2 Impact protective systems testing and labeling Impact protective systems shall be tested for impact resistance by an approved independent laboratory for compliance with ASTM E 1886 and ASTM E 1996. Impact protective systems shall also be tested for design wind pressure by an approved independent laboratory for compliance with ASTM E 330. Required design wind pressures shall be determined in accordance with Table R301.2(2) adjusted for height and exposure in accordance with Table R301.2(3) or determined in accordance with ASCE 7. For the purposes of this section, design wind pressures determined in accordance with ASCE 7 are permitted to be multiplied by 0.6.

Impact protective systems bear a label identifying the manufacturer, performance characteristics, and approved inspection agency. Impact protective systems shall have a permanent label providing traceability to the manufacturer, product designation, and performance characteristics. The permanent label shall be acid etched, sand blasted, ceramic fired, laser etched, embossed or of a type that, once applied, cannot be removed without being destroyed.

Reason: This proposal is one of several that are addressing labeling of critical components of the building envelope. The primary purpose of this code change is to require that impact protective systems (hurricane shutters) have a permanent label that provides a way for building owners, homeowners, and others to be able to determine their performance characteristics after the building has been occupied. The 2015 IRC does not require any type of label for impact protective systems. For products that don't have permanent labels, it becomes nearly impossible for the owner to determine the structural wind load resistance and impact resistance of the products after they've occupied the building. This proposal would simply require some type of permanent marking on the impact protective system indicating the manufacturer and model/series number, and performance characteristics so that the specific performance characteristics could be retrieved at a later date. The permanent label would only need to provide traceability to the product. However, it could provide all the required information. If the relevant information is not provided on a permanent label, a temporary removable label is required to be applied so that local code officials can verify that the appropriate impact protective system was provided.

For the past 10-15 years, there has been a push towards considering sustainability in the way our buildings are constructed in this country. If this goal is to be successful and building owners and occupants increasingly want more information about the

sustainability of the buildings they occupy, they need to be provided ways to be able to determine how critical components are expected to perform in the buildings they use. Impact protective systems are important components of the building envelope and their performance is critical to maintaining the overall structural integrity of the building. Some manufacturers already include permanent labels on their products that provide traceability to the manufacture and the product characteristics. The Florida Building Code has required a permanent label since the 2007 edition and has continued to require it in subsequent editions. The following is the relevant text from the 5th Edition (2014) Florida Building Code, Residential:

R615.1 Impact resistant coverings shall be tested at 1.5 times the design pressure (positive or negative) expressed in pounds per square feet as determined by the Florida Building Code, Building Section 1609 for which the specimen is to be tested. The design pressures, as determined from Section 1609 of the Florida Building Code, Building or ASCE 7, are permitted to be multiplied by 0.6.

R615.1.1 Impact resistant coverings shall be labeled in accordance with the provisions of Section R615.

R615.2. Labels. A permanent label shall be provided by the product approval holder on all impact resistant coverings.

Another consideration is that insurance incentives are now being offered in several states for homes, new and existing, that comply with certain levels of the Fortified program administered by IBHS. The Fortified program is a set of engineering and building standards designed to help strengthen new and existing homes through system-specific building upgrades to minimum building code requirements that will reduce damage from specific natural hazards. Fortified offers three different levels of designation (bronze, silver, and gold) depending on the extent of the recommended "upgrades" to the building's wind resistance. To qualify for a designation, the home has to be inspected. Without a permanent label providing traceability to the manufacturer and product, the performance characteristics often cannot be determined, and certain Fortified designations become difficult or impossible to be given.

This proposal also provides some additional clarification for impact protective systems that is lacking in the IRC. New Section R609.6.2 clarifies that impact protective systems also have to be capable of resisting the required design wind pressure as well as the impact criteria. New language is added to clarify the relationship between design wind loads calculated in accordance with ASCE 7-10 and the wind load testing requirements of ASTM E 330.

Approval of this proposal will assure, going forward, that new or replaced impact protective systems will be labeled such that building owners and those considering the purchase of buildings with these products will be able to obtain information necessary for determining the expected performance of these critical components used to protect the building envelope in hurricane prone areas.

Cost Impact: Will increase the cost of construction

Will result in an increase in cost. A consultant representing the industry estimates the cost of providing labels on impact resistant covering products to be as follows:

- a. Water Resistant Self-adhering Permanent Labels approximately \$0.15 per label. Such labels would most likely be used on Accordion, Roll, Bahama, and Colonial style shutters.
- b. Embossed or ink jet labels used on metal and plastic panels would cost approximately \$0.05 per label.

Report of Committee Action Hearings

Committee Action:

Approved as Submitted

Committee Reason: This is a needed change because it is difficult to identify whether a hurricane shutter or impact protective system meets the code specified requirements. Requiring a permanent label will alleviate this problem.

Assembly Action:

None

Final Action Results

RB259-16

AS

[←BACK](#)

Code Change No: **RB260-16**

Original Proposal

Section: R702.2.1

Proponent: G Michael Starks, In-Spex, LLC, C B Goldsmith & assoc., FloridaLath & Plaster Bureau, representing In-Spex, LLC (mstarks@in-spexllc.com)

Revise as follows:

R702.2.1 Gypsum plaster. Gypsum plaster materials shall conform to ASTM C 5, C 22, C 28, C 35, C 59, C 61, C 587, C 631, C 847, C 933, C 1032 and C 1047, and shall be installed or applied in compliance with ASTM ~~C841~~, ~~C 843~~~~842~~ and ~~C 844~~~~843~~. Gypsum lath or gypsum base for veneer plaster shall conform to ASTM C 1396 and shall be installed in compliance with ASTM C 844. Plaster shall be not less than three coats where applied over metal lath and not less than two coats where applied over other bases permitted by this section, except that veneer plaster shall be applied in one coat not to exceed $3/16$ inch (4.76 mm) thickness, provided the total thickness is in accordance with Table R702.1(1).

Reference standards type: This reference standard is new to the ICC Code Books
Add new standard(s) as follows:

ASTM C 841-03 (Reapproved 2013) Standard Specification for Installation of Interior Lathing and Furring;
ASTM C 842-05 (Reapproved 2015) Standard Specification for Application of Interior Gypsum Plaster;

Reason: As currently written, the Code eliminates the use of full-depth plaster in favor of veneer plaster. However, the values in Table R702.1(1) Thickness of Plaster, reflect the values of ASTM C 842, *Standard Specification for Application of Interior Gypsum Plaster*. Thickness values for C 843, *Standard Specification for Application of Gypsum Veneer Plaster*, are much thinner. In addition, application of gypsum base is covered in the current reference standard, ASTM C 844.

Bibliography: ASTM C 841-03 (Reapproved 2013) *Standard Specification for Installation of Interior Lathing and Furring* - www.astm.org
 ASTM C 842-05 (Reapproved 2015) *Standard Specification for Application of Interior Gypsum Plaster*, pg 2, www.astm.org
 ASTM C 843-99 (Reapproved 2012) *Standard Specification for Application of Gypsum Veneer Plaster*, pg 3, www.astm.org

Cost Impact: Will not increase the cost of construction
 There is no cost of construction significance in this item.

Analysis: A review of the standard(s) proposed for inclusion in the code, ASTM C841-03 and ASTM 842-05, with regard to the ICC criteria for referenced standards (Section 3.6 of CP#28) will be posted on the ICC website on or before April 1, 2016.

Report of Committee Action Hearings

Committee Action:

Approved as Submitted

Committee Reason: The committee approved this proposal based on the proponents published reason statement.

Assembly Action:

None

Final Action Results

RB260-16

AS

[←BACK](#)

Code Change No: **RB261-16**

Original Proposal

Section: R702.2.2

Proponent: G Michael Starks, In-Spex, LLC, C B Goldsmith & assoc., Florida Lath & Plaster Bureau, representing In-Spex, LLC (mstarks@in-spexllc.com)

Revise as follows:

R702.2.2 Cement plaster. Cement plaster materials shall conform to ASTM C 91 (Type M, S or N), C 150 (Type I, II and III), C 595 [Type IP, I (PM), IS and I (SM), C 847, C 897, ~~C 926,~~ C 933, C 1032, C 1047 and C 1328, and shall be installed or applied in compliance with ASTM C 926 and C 1063. Gypsum lath shall conform to ASTM C 1396. Plaster shall be not less than three coats where applied over metal lath and not less than two coats where applied over other bases permitted by this section, ~~except that veneer plaster shall be applied in one coat not to exceed $\frac{3}{16}$ inch (4.76 mm) thickness, provided the total thickness is in accordance with Table R702.1(1).~~

Reason: Currently there is an misplacement error in the reference standards as listed in the current section. ASTM C 926, Standard Specification for Application of Portland Cement-Based Plaster, is an application standard and belongs after "...in compliance with" prior to "ASTM C 1063."

Bibliography: ASTM C 926-13 *Standard specification for Application of Portland Cement-Based Plaster*;

Cost Impact: Will not increase the cost of construction
There is no cost of construction significance in this item.

Report of Committee Action Hearings

Committee Action:

Approved as Submitted

Committee Reason: The proposal corrects a standard pointer to the installation portion and eliminates erroneous statements about the veneer thickness at the end of the section.

Assembly Action:

None

Final Action Results

RB261-16

AS

Code Change No: **RB264-16**

Original Proposal

Section: R702.3.1

Proponent: Mike Fischer, Kellen, representing The Gypsum Association, representing Gypsum Association (mfischer@kellencompany.com)

Revise as follows:

R702.3.1 Materials. Gypsum board and gypsum panel product materials and accessories shall conform to ASTM C 22, C 475, C 514, C 1002, C 1047, C 1177, C 1178, C 1278, C 1396 ~~or~~, C 1658, or C1766, and shall be installed in accordance with the provisions of this section. Adhesives for the installation of gypsum board and gypsum panel products shall conform to ASTM C 557.

Reference standards type: This reference standard is new to the ICC Code Books
Add new standard(s) as follows:

ASTM C 1766-13 Standard Specification for Factory-Laminated Gypsum Panel Products

Reason: ASTM C1766 was developed by ASTM subcommittee C11.01, assigned the responsibility for the development and maintenance of test methods and materials for gypsum products. Standard C 1766 addresses gypsum panel products, laminated in the factory, that are designed for use in sound control (in ceilings, walls, partitions etc.) or for gypsum studs or coreboards. Adding the standard to R702.3.1 will help ensure that the latest available information and product standards for these panels are appropriately applied.

Cost Impact: Will not increase the cost of construction

The proposal adds in a product standard that extends performance requirements for factory-laminated products to meet the current intent of the code. The proposal increases product selection options, but contains no mandatory requirements.

Analysis: A review of the standard(s) proposed for inclusion in the code, ASTM C1766-13, with regard to the ICC criteria for referenced standards (Section 3.6 of CP#28) will be posted on the ICC website on or before April 1, 2016.

Report of Committee Action Hearings

Committee Action:

Approved as Submitted

Committee Reason: The proposal adds an appropriate new standard for a specific gypsum panel product.

Assembly Action:

None

Final Action Results

RB264-16

AS

Code Change No: **RB265-16**

Original Proposal

Section: R702.3.3

Proponent: Jon-Paul Cardin, American Iron and Steel Institute, representing American Iron and Steel Institute (JCardin@steel.org)

Revise as follows:

R702.3.3 Cold-formed steel framing. Cold-formed steel framing supporting gypsum board and gypsum panel products shall be not less than 1 1/4 inches (32 mm) wide in the least dimension. Nonload-bearing cold-formed steel framing shall comply with AISI S220 and ASTM C645, Section 10. Load-bearing cold-formed steel framing shall comply with AISI S200 and ASTM C955, Section 8 ~~S240~~.

Reference standards type: This reference standard is new to the ICC Code Books
Add new standard(s) as follows:

AISI S240-15, North American Standard for Cold-Formed Steel Structural Framing (2015)

Standards Available for free download at www.aisistandards.org

Reason: This proposal is one in a series intended to update the content of the cold-formed steel (CFS) light-framed construction provisions of the IRC. The screw penetration test, as referenced to ASTM C645, Section 10, has been incorporated into AISI S220-15, *North American Standard for Cold-Formed Steel Framing - Non-Structural Members*. Therefore, the reference to AISI S220 is adequate to cover those requirements.

In addition, this section previously referenced AISI S200 for load-bearing cold-formed steel framing. However, the new standard **AISI S240**, *North American Standard for Cold-Formed Steel Structural Framing*, addresses requirements for construction with cold-formed steel structural framing that are common to prescriptive and engineered light frame construction. This comprehensive standard was formed by merging the following AISI standards:

- AISI S200, *North American Standard for Cold-Formed Steel Framing-General Provisions*
- AISI S210, *North American Standard for Cold-Formed Steel Framing-Floor and Roof System Design*
- AISI S211, *North American Standard for Cold-Formed Steel Framing-Wall Stud Design*
- AISI S212, *North American Standard for Cold-Formed Steel Framing-Header Design*
- AISI S213, *North American Standard for Cold-Formed Steel Framing-Lateral Design*
- AISI S214, *North American Standard for Cold-Formed Steel Framing-Truss Design*

Consequently, AISI S240 supersedes all previous editions of the above mentioned individual AISI standards and is the correct reference for this application.

The additional screw penetration test, as referenced to ASTM C955 Section 8, is intended for load-bearing CFS framing members. Through the ANSI approved process of developing AISI S240-15, it was the consensus of the AISI Committee on Framing Standards that the screw penetration test was not necessary for load-bearing CFS framing members. The basis of the determination is that the test never produced a failed result for the thickness of members used in structural framing applications. Therefore, the screw penetration test of ASTM C955 Section 8 was not included in AISI S240-15, and is not required as a separate reference in this section of the IRC.

Cost Impact: Will not increase the cost of construction

This proposal is intended to update the referenced AISI standards and does not effect the intended prescribed construction requirements.

Analysis: A review of the standard(s) proposed for inclusion in the code, AISI 240-15, with regard to the ICC criteria for referenced standards (Section 3.6 of CP#28) will be posted on the ICC website on or before April 1, 2016.

**Report of Committee Action
Hearings**

Committee Action:

Approved as Submitted

Committee Reason: The committee approved this proposal based on the proponents published reason statement. The new standard merged 6 standards into one and eliminated the need to reference some standards since the requirements are in the new standard..

Assembly Action:

None

Final Action Results

RB265-16

AS

[←BACK](#)

Code Change No: RB276-16**Original Proposal****Section: R702.7.3**

Proponent: Matthew Dobson, Vinyl Siding Institute, representing Vinyl Siding Institute

Revise as follows:

R702.7.3 Minimum clear airspaces and vented openings for vented cladding. For the purposes of this section, vented cladding shall include the following minimum clear airspaces. Other openings with the equivalent vent area shall be permitted.

1. Vinyl-lap, polypropylene, or horizontal aluminum siding applied over a weather-resistive barrier as specified in Table R703.3(1).
2. Brick veneer with a clear airspace as specified in Table R703.8.4.
3. Other approved vented claddings.

Reason: Polypropylene siding is very similar to vinyl siding in its shape and design and has similar "vented cladding" characteristics. We are asking for recognition of this with respect to vapor barriers.

Below are photos of a typical vinyl siding profile and a typical polypropylene siding profile. The similarities are self-evident.





Cost Impact: Will not increase the cost of construction
This change simply identifies another type of vented cladding.

**Report of Committee Action
Hearings**

Committee Action:

Approved as Submitted

Committee Reason: The committee approved this proposal based on the proponents published reason statement. The added material has similar venting characteristics as the other materials in Item 1.

Assembly Action:

None

Final Action Results

RB276-16

AS

[←BACK](#)

Code Change No: **RB280-16**

Original Proposal

Section: R703.1.1

Proponent: Edward Keith, representing APA- The Engineered Wood Association (ed.keith@apawood.org)

Revise as follows:

R703.1.1 Water resistance. The exterior wall envelope shall be designed and constructed in a manner that prevents the accumulation of water within the wall assembly by providing a water-resistant barrier behind the exterior ~~veneer cladding~~ as required by Section R703.2 and a means of draining to the exterior water that enters the assembly. ~~Protection against condensation in penetrates the exterior wall assembly shall be provided in accordance with Section R702.7 of this code cladding.~~

Exceptions:

1. A weather-resistant exterior wall envelope shall not be required over concrete or masonry walls designed in accordance with Chapter 6 and flashed in accordance with Section R703.4 or R703.8.
2. Compliance with the requirements for a means of drainage, and the requirements of Sections R703.2 and R703.4, shall not be required for an exterior wall envelope that has been demonstrated to resist wind-driven rain through testing of the exterior wall envelope, including joints, penetrations and intersections with dissimilar materials, in accordance with ASTM E 331 under the following conditions:
 - 2.1. Exterior wall envelope test assemblies shall include at least one opening, one control joint, one wall/eave interface and one wall sill. All tested openings and penetrations shall be representative of the intended end-use configuration.
 - 2.2. Exterior wall envelope test assemblies shall be at least 4 feet by 8 feet (1219 mm by 2438 mm) in size.
 - 2.3. Exterior wall assemblies shall be tested at a minimum differential pressure of 6.24 pounds per square foot (299 Pa).
 - 2.4. Exterior wall envelope assemblies shall be subjected to the minimum test exposure for a minimum of 2 hours. The exterior wall envelope design shall be considered to resist wind-driven rain where the results of testing indicate that water did not penetrate control joints in the exterior wall envelope, joints at the perimeter of openings penetration or intersections of terminations with dissimilar materials.

Reason: The term "veneer" can be misleading as its original meaning refers to a thin decorative covering. Certain siding products can exhibit structural and thermal properties which goes beyond being decorative. "Cladding," on the other hand, is a more general term that can be applied to a wider range of products. The term "enters the assembly" can be misleading as it may suggest water penetrating into the structural assembly (i.e. stud cavity), which can no longer be drained to the exterior. Draining of exterior water should only apply to the water that has penetrated or passed through the first line of defense, the cladding. The last sentence does not belong in this section of the code and is addressed in the APA code change proposal on R702.7.

Cost Impact: Will not increase the cost of construction
This code change will not increase the cost of construction as it clarifies the intent of the original code provisions.

Public Hearing Results

Committee Action:

Approved as Submitted

Committee Reason: The committee approved this proposal based on the proponents published reason statement. The change to the word cladding improves the wording of the code.

Assembly Action:

None

Final Action Results

RB280-16

AS

[←BACK](#)

Code Change No: **RB282-16**

Original Proposal

Section: R703.1.2, R703.11.1.4, R703.3, R703.3.1, R703.3.1 (New), R703.3.1.1 (New), R703.3.2

Proponent: T. Eric Stafford, PE, representing AECOM; Andrew Herseth, representing Federal Emergency Management Agency (andrew.herseth@fema.dhs.gov)

Revise as follow:

R703.1.2 Wind resistance. Wall coverings, roof overhang soffits, backing materials and their attachments shall be capable of resisting wind loads in accordance with Tables R301.2(2) and R301.2(3). Wind-pressure resistance of the siding, soffit, and backing materials shall be determined by ASTM E 330 or other applicable standard test methods. Where wind-pressure resistance is determined by design analysis, data from approved design standards and analysis conforming to generally accepted engineering practice shall be used to evaluate the siding, soffit, and backing material and its fastening. All applicable failure modes including bending rupture of siding, fastener withdrawal and fastener head pull-through shall be considered in the testing or design analysis. Where the wall covering, soffit, and the backing material resist wind load as an assembly, use of the design capacity of the assembly shall be permitted.

R703.3 Nominal Wall covering nominal thickness and attachments. The nominal thickness and attachment of exterior wall coverings shall be in accordance with Table R703.3(1), the wall covering material requirements of this section, and the wall covering manufacturer's installation instructions. Cladding attachment over foam sheathing shall comply with the additional requirements and limitations of Sections R703.15 through R703.17. Nominal material thicknesses in Table R703.3(1) are based on a maximum stud spacing of 16 inches (406 mm) on center. Where specified by the siding manufacturer's instructions and supported by a test report or other documentation, attachment to studs with greater spacing is permitted. Fasteners for exterior wall coverings attached to wood framing shall be in accordance with Section ~~R703.3.2~~ R703.3.3 and Table R703.3(1). Exterior wall coverings shall be attached to cold-formed steel light frame construction in accordance with the cladding manufacturer's installation instructions, the requirements of Table R703.3(1) using screw fasteners substituted for the nails specified in accordance with Table R703.3(2), or an approved design.

~~R703.3.1~~ R703.3.2 Wind limitations. Where the design wind pressure exceeds 30 psf or where the limits of Table ~~R703.3.1~~ R703.3.2 are exceeded, the attachment of wall coverings and roof overhang soffits shall be designed to resist the component and cladding loads specified in Table R301.2(2), adjusted for height and exposure in accordance with Table R301.2(3). For the determination of wall covering and roof overhang soffit attachment, component and cladding loads shall be determined using an effective wind area of 10 square feet (0.93 m²).

TABLE ~~R703.3.1~~ R703.3.2
LIMITS FOR ATTACHMENT PER TABLE R703.3(1)

For SI: 1 foot = 304.8 mm, 1 mile per hour = 0.447 m/s.
NL = Not limited by Table R703.3.1, DR = Design required.

~~R703.3.2~~ R703.3.3 Fasteners. Exterior wall coverings and roof overhang soffits shall be securely fastened with aluminum, galvanized, stainless steel or rust-preventative coated nails or staples in accordance with Table R703.3(1) or with other approved corrosion-resistant fasteners in accordance with

the wall covering manufacturer's installation instructions. Nails and staples shall comply with ASTM F 1667. Nails shall be T-head, modified round head, or round head with smooth or deformed shanks. Staples shall have a minimum crown width of $7/16$ inch (11.1 mm) outside diameter and be manufactured of minimum 16-gage wire. Where fiberboard, gypsum, or foam plastic sheathing backing is used, nails or staples shall be driven into the studs. Where wood or wood structural panel sheathing is used, fasteners shall be driven into studs unless otherwise permitted to be driven into sheathing in accordance with either the siding manufacturer's installation instructions or Table R703.3.2.

R703.3.1 Roof overhang soffit nominal thickness and attachment. The minimum nominal thickness for wood structural panel roof overhang soffits shall be in accordance with Table R703.3(1). Fasteners for wood structural panel roof overhang soffits shall be in accordance with Section R703.3.3 and Table R703.3(1). Manufactured soffit panels shall be installed in accordance with the manufacturer's installation instruction for the design wind loads required in Section R703.1.2.

Reason: Little guidance is given in the code for soffit installation and design loads on soffits. The 2004 hurricane season resulted in significant damage to soffit panels in the State of Florida and resultant wind and water damage to many buildings. Further research revealed inconsistencies in the way loads were being calculated for roof overhang soffits. At the time, neither the codes nor ASCE 7 provided any guidance on the appropriate loads for the design of soffit panels. As a result, the 2007 Florida Building Code was revised to include new language specifically requiring soffits to be designed using the wall GCp coefficients based on an effective wind area of 10 square feet. Additionally, ASCE 7-10 addressed the issue by stating that the external pressure coefficient on underside of the roof overhang is the same as the adjacent wall surface adjusted for effective wind area. This language in ASCE 7-10 is somewhat ambiguous and is not readily identifiable. It is located in the definition of GCp in Section 30.10 for roof overhangs. While design loads for soffits are addressed in the 2014 Edition of ICC 600, they are not addressed in some of the other prescriptive documents referenced by the IRC. This language simply seeks to clarify the design loads that are to be used on soffits.

The Hurricane Charley Mitigation Team Assessment (MAT) report (FEMA 488) identified widespread damage to vinyl and aluminum soffit panels, particularly on residential buildings. See Sections 8.2.2, 8.5, and 8.7.1 in FEMA 488. These panels were either pulled out by negative wind pressures (suction) or pushed up by positive pressures (Figure 3-21 from the Hurricane Charley MAT and Figure 1 from FEMA 499 Technical Fact Sheet No. 7.5). The damage was often not limited to the loss of the exterior soffit cladding system. Damages to these building envelope components led to wind-driven rain entering the homes and wetting the building interior and the internal wall cavities, and saturating attic insulation and ceilings that sometimes collapsed (Figure 3-22 from the Hurricane Charley MAT).

Additionally, the IRC doesn't specifically address soffit installation for low wind regions (areas where wind design is not required in accordance with Figure R301.2(4)B). Most of the nominal thicknesses and fastening requirements in Table R703.3(1) would not apply to soffit panels, with the exception of wood structural panel. Since the design wind pressures on the soffit are the same as the adjacent wall surface, the requirements for wood structural panel wall coverings would be acceptable for wood structural panel soffit panels. New Section R703.3.1 has been added requiring wood structural panel soffits to comply with Table R703.3.1 and Section R703.3.3 (formerly R703.3.2). Manufactured soffit panels have general installation instructions, but also include installation instructions for specific wind loads. The new language refers to the installation instructions for manufactured soffit panels but also emphasizes that the soffit panel has to be capable of resisting the design loads in Table R301.2(2) even in lower wind regions.

It's important to note that this code change does not add additional wind loading requirements for manufactured soffits. The materials and fastening requirements in Table R703.3(1) were prescriptively developed to resist a design wind pressure of 30 psf. This code change simply requires manufactured soffit panels to be installed to resist the minimum design wind pressure applicable.



Figure 1. Missing soffit material.

Figure 3-21. Typical elevated wood-frame house with extensive soffit damage (North Captiva Island)





Figure 3-22. The drywall ceiling in the home shown in Figure 3-21 collapsed after becoming waterlogged and weakened by wind-driven rain that entered through the exterior soffit space. Plywood covers the opening of a window broken by windborne debris after the plastic shutters blew off (North Captiva Island).

Bibliography: FEMA 488, Mitigation Assessment Team Report: Hurricane Charley in Florida (2005)
Homebuilders Guide to Coastal Construction Technical Fact Sheet Series - FEMA P-499

Cost Impact: Will increase the cost of construction

May result in an increase in the cost of construction for lower wind regions as the IRC doesn't specifically address soffit installation or attachment. However, any initial minimal up front construction costs will result in reduced owner residual risk through improved resilience to high wind loading, reduced wind driven rain associated damages and more than offset costs through mitigating already well documented failure modes and vulnerabilities.

Report of Committee Action Hearings

Committee Action:

Approved as Modified

Modify as follows:

R703.1.2 Wind resistance. Wall coverings, ~~roof overhang soffits,~~ backing materials and their attachments shall be capable of resisting wind loads in accordance with Tables R301.2(2) and R301.2(3). Wind-pressure resistance of the siding, ~~soffit,~~ and backing materials shall be determined by ASTM E 330 or other applicable standard test methods. Where wind-pressure resistance is determined by design analysis, data from approved design standards and analysis conforming to generally accepted engineering practice shall be used to evaluate the siding, ~~soffit,~~ and backing material and its fastening. All applicable failure modes including bending rupture of siding, fastener withdrawal and fastener head pull-through shall be considered in the testing or design analysis. Where the wall covering, ~~soffit,~~ and the backing material resist wind load as an assembly, use of the design capacity of the assembly shall be permitted.

R703.3.1 Soffit installation Soffits shall comply with Sections R703.3.1.1, Section R703.3.1.2, or the manufacturer's installation instructions.

R703.3.1.1 Roof overhang Wood structural panel soffit nominal thickness and attachment. The minimum nominal thickness for wood structural panel ~~roof overhang~~ soffits shall be $\frac{3}{8}$ in accordance, and shall be fastened to framing or nailing strips with ~~Table R703.3(1) 2" x 0.099" nails.~~ Fasteners for wood structural panel ~~roof overhang~~ soffits shall be in accordance with ~~Section R703.3.3 spaced not less than 6 inches on center at panel edges and Table R703.3(1)-12 inches on center at intermediate supports.~~ Manufactured soffit panels shall be installed in accordance with the manufacturer's installation instruction for the design wind loads required in Section R703.1.2.

R703.11.1.4 R703.3.1.2 Vinyl soffit panels. Soffit panels shall be individually fastened at fascia and wall ends and to a supporting component such ~~intermediate nailing strips as a nailing strip necessary to ensure that there is no unsupported span greater than 16 inches,~~ fascia or subfascia component, or as specified by the manufacturer's instructions.

R703.3.2 Wind limitations. Where the design wind pressure exceeds 30 psf or where the limits of Table R703.3.2 are exceeded, the attachment of wall coverings and ~~roof overhang~~ soffits shall be designed to resist the component and cladding loads specified in Table R301.2(2) ~~for walls,~~ adjusted for height and exposure in accordance with Table R301.2(3). For the determination of wall covering and ~~roof overhang~~ soffit attachment, component and cladding loads shall be determined using an effective wind area of 10 square feet (0.93 m²).

Committee Reason: With the modification this proposal will improve the durability of soffits in high wind regions while allowing continued use of traditional soffit materials in the low wind regions. The modification solves a lot of problems with the original proposal and provides prescriptive requirements and reference to manufacturers instructions for soffits in low wind regions while providing performance requirement for high wind regions.

Assembly Action

None

Final Action Results

RB282-16

AM

[←BACK](#)

Code Change No: **RB283-16**

Original Proposal

Section: R703.2

Proponent: Jay Crandell, P.E., ARES Consulting, representing Foam Sheathing Committee of the American Chemistry Council

Revise as follows:

R703.2 Water-resistive barrier. One layer of No. 15 asphalt felt, free from holes and breaks, complying with ASTM D 226 for Type 1 felt or other approved water-resistive barrier shall be applied over studs or sheathing of all exterior walls. ~~Such No. 15 asphalt felt or material shall be applied horizontally, with the upper layer lapped over the lower layer not less than 2 inches (51 mm). Where joints occur, felt shall be lapped not less than 6 inches (152 mm). Other approved materials shall be installed in accordance with the *water-resistive barrier* manufacturer's installation instructions.~~ The No. 15 asphalt felt or other approved *water-resistive barrier* material shall be continuous to the top of walls and terminated at penetrations and building appendages in a manner to meet the requirements of the exterior wall envelope as described in Section R703.1. The water-resistive barrier is not required for detached accessory buildings.

Reason: This proposal clarifies requirements for No. 15 asphalt felt and distinguishes requirements for other approved water-resistive barriers (WRBs) to improve application and enforceability. The specific installation instructions currently provided in the code apply only to a traditional application of No.15 asphalt felt (and some types of membrane WRBs, but not always) and are exclusionary if applied to all other approved WRB materials as the code currently implies. While some other approved materials may use the same or similar installation details, they are frequently different. Also, the lapping method is impractical and exclusionary for some other approved materials, such as sheathing-type WRBs, that rely on approved sealed joints (e.g., adhered flashing or joint sealing tape) which also are used to enhance minimally lapped joints on membrane-type WRBs (and are often required at intersections with penetrations to provide continuity of the WRB). Thus, the phrase "or material" is stricken to avoid the unintended (and exclusionary) implication that all "other approved materials" (as mentioned in the first sentence) must be installed like No. 15 asphalt felt with lapped joints (as indicated in the second sentence for other materials than No. 15 felt). In coordination with the above change, it is made clear that other approved materials shall be installed in accordance with the manufacturer's installation instructions. Finally, it is made clear that continuity of the WRB (last sentence) applies to both No. 15 asphalt felt and any other approved WRB material.

Cost Impact: Will not increase the cost of construction
The proposal clarifies requirements and may actually help avoid unintended cost impacts or material choice limitations.

Report of Committee Action Hearings

Committee Action:

Approved as Submitted

Committee Reason: The committee approved this proposal based on the proponents published reason statement. This clarifies the horizontal application and lapping only applies to No.15 felt.

Assembly Action:

None

Final Action Results

RB283-16

AS

Code Change No: **RB284-16**

Original Proposal

Section: R703.2

Proponent: Brent Ursenbach (bursenbach@slco.org)

Revise as follows:

R703.2 Water-resistive barrier. One layer of No. 15 asphalt felt, free from holes and breaks, complying with ASTM D 226 for Type 1 felt or other approved water-resistive barrier shall be applied over studs or sheathing of all exterior walls. Such felt or material shall be applied horizontally, with the upper layer lapped over the lower layer not less than 2 inches (51 mm). Where joints occur, felt shall be lapped not less than 6 inches (152 mm). The felt or other approved material shall be continuous to the top of walls and terminated at penetrations and building appendages in a manner to meet the requirements of the exterior wall envelope as described in Section R703.1. ~~The water-resistive barrier is not required for detached accessory buildings.~~

Reason: Not requiring a water-resistive barrier for detached accessory building is illogical. Please consider:

- Why is it ok to allow water intrusion behind exterior coverings in an accessory building? The wall sheathing and framing will experience the same damaging affect of moisture as a SFD will experience.
- Virtually all exterior wall covering manufacturers require a water resistive barrier under their products.
- Vinyl siding installer typically seek to use this except to allow installation of vinyl siding over sheathing on exterior walls of detached garages and storage sheds; however the siding manufacturers installation instructions specifically state their product should not be considered a water resistive barrier.
- *Quoting the Vinyl Siding Institute Installation Manual: Vinyl siding, insulated siding, and polypropylene siding are exterior claddings, not water-resistive barriers, and are designed to allow the material underneath to breathe. This factor provides a supplemental rain-screen that reduces the amount of water that reaches an underlying water-resistive barrier. To achieve designed performance, and to comply with the 2015 International Residential Code, vinyl siding, insulated siding, and polypropylene siding must be installed over a water-resistive barrier, which is intended to prevent liquid water that has penetrated behind the exterior covering from further intruding into the exterior wall assembly.*
- Eliminating this exception will provide clarity to the code in that the water-resistive barrier is required by the manufacturers, insuring the products are installed correctly.

Cost Impact: Will not increase the cost of construction

There is no cost impact as the water-resistive barrier is required by the manufacturer and should already be including in the cost of the installation. This code change simply eliminates confusion.

Report of Committee Action Hearings

Committee Action:

Approved as Submitted

Committee Reason: The committee approved this proposal based on the proponents published reason statement. This should not be in the code. The siding manufactures installation instructions require the WRB regardless of the building use.

Assembly Action:

None

Final Action Results

RB284-16

AS

Code Change No: RB296-16

Original Proposal

Section: R702.1, R703.7, R703.7.1, R703.7.2

Proponent: William Hall, Portland Cement Association (jhall@cement.org); Stephen Szoke, Portland Cement Association, representing Portland Cement Association (sszoke@cement.org)

Revise as follows:

TABLE R702.1 (3)
CEMENT PLASTER PROPORTIONS, PARTS BY VOLUME

COAT	CEMENT PLASTER TYPE	CEMENTITIOUS MATERIALS				VOLUME OF AGGREGATE PER SUM OF SEPARATE VOLUMES OF CEMENTITIOUS MATERIALS ^b
		Portland Cement Type I, II or III; Blended Hydraulic Cement Type IP, PM-I(S<70) , IL, or IT(S<70); or Hydraulic Cement Type GU, HE, MS, HS, or MH	Plastic Cement	Masonry Cement Type M, S or N	Lime	
First	Portland or blended	1			$\frac{3}{4} - 1\frac{1}{2}$ ^a	$2\frac{1}{2} - 4$
	Masonry			<u>1</u>	4	$2\frac{1}{2} - 4$
	Plastic		1			$2\frac{1}{2} - 4$
Second	Portland or blended	1			$\frac{3}{4} - 1\frac{1}{2}$	3 - 5
	Masonry			1		3 - 5
	Plastic		1			3 - 5
Finish	Portland or blended	1			$\frac{3}{4} - 2$ <u>$1\frac{1}{2} - 2$</u>	$1\frac{1}{2} - 3$
	Masonry			1		$1\frac{1}{2} - 3$
	Plastic		1			$1\frac{1}{2} - 3$

For SI: 1 inch = 25.4 mm, 1 pound = 0.454 kg.

a. Lime by volume of 0 to $\frac{3}{4}$ shall be used where the plaster will be placed over low-absorption surfaces such as dense clay tile or brick.

b. The same or greater sand proportion shall be used in the second coat than used in the first coat.

Revise as follows:

R703.7 Exterior plaster (stucco). *No change to text.*

R703.7.1 Lath. Lath and lath attachments shall be of corrosion-resistant materials. Expanded metal or woven wire lath shall be attached with $1\frac{1}{2}$ -inch-long (38 mm), 11 gage nails having a $\frac{7}{16}$ -inch (11.1 mm) head, or $\frac{7}{8}$ -inch-long (22.2 mm), 16 gage staples, spaced not more than 6 inches (152 mm), or as otherwise approved.

Exception: Lath is not required over masonry, cast-in-place concrete, precast concrete or stone substrates prepared in accordance with ASTM C1063.

R703.7.2 Plaster. Plastering with portland cement plaster shall be in accordance with ASTM C926. Cement materials shall be in accordance with one of the following:

Masonry cement plaster conforming to ASTM C91 Type M, S or N
Portland cement conforming to ASTM C150 Type I, II, or III;
Blended hydraulic cement conforming to ASTM C595 Type IP, IS(<70), IL, or IT(S<70);
Hydraulic cement conforming to C1157 Type GU, HE, MS, HS, or MH; or
Plastic (stucco) cement conforming to C 1328.

Plaster shall be not less than three coats where applied over metal lath or wire lath and shall be not less than two coats where applied over masonry, concrete, pressure-preservative-treated wood or decay-resistant wood as specified in Section R317.1 or gypsum backing. If the plaster surface is completely covered by veneer or other facing material or is completely concealed, plaster application need be only two coats, provided the total thickness is as set forth in Table R702.1(1).

On wood-frame construction with an on-grade floor slab system, exterior plaster shall be applied to cover, but not extend below, lath, paper and screed.

The proportion of aggregate to cementitious materials shall be as set forth in Table R702.1(3).

Reason: The purpose of this code change is to correlate the requirements for exterior lath and plaster (stucco) with the requirements of ASTM C926 and C1063 and ACI 524R-08 Guide to Portland Cement-Based Plaster The code requirements in the IRC are not in alignment with the reference standards and industry recommended practice. This change clarifies that lath is not required for stucco to be applied to masonry, concrete or stone surfaces and updates the acceptable types of cement to current ASTM designations.

Bibliography: ACI 524R-08 Guide to Portland Cement-Based Plaster

Cost Impact: Will not increase the cost of construction

The code change will not increase the cost of construction. The change corrects the designations for acceptable, currently available cement types clarifies that lath is not required where stucco is permitted to be placed directly on concrete or masonry surfaces.

Report of Committee Action Hearings
--

Committee Action:

Approved as Submitted

Committee Reason: The committee approved this proposal based on the proponents published reason statement. This proposal updates and brings information from the referenced standards into the text and tables.

Assembly Action:

None

Final Action Results

RB296-16

AS

[←BACK](#)

Code Change No: **RB303-16**

Original Proposal

Section(s): R703.8.4, R703.8.4(2) (New)

Proponent: Edward Keith, representing APA- The Engineered Wood Association (ed.keith@apawood.org)

Revise as follows:

R703.8.4 Anchorage. Masonry veneer shall be anchored to the supporting wall studs with corrosion-resistant metal ties embedded in mortar or grout and extending into the veneer a minimum of 1½ inches (38 mm), with not less than ⅝-inch (15.9 mm) mortar or grout cover to outside face. Masonry veneer tie attachment and air space requirements shall conform to Table R703.8.4R703.8.4(1). For brick tie attachment recommendations when brick ties are attached to wood structural panel sheathing only, see Table R703.8.4(2).

TABLE R703.8.4(2)
BRICK TIE MINIMUM FASTENING REQUIREMENTS (VERTICAL TIE SPACING/ HORIZONTAL TIE SPACING)
FOR DIRECT APPLICATION OVER UP TO TWO INCHES OF FOAM TO MINIMUM 7/16 PERFORMANCE
CATEGORY WOOD STRUCTURAL PANEL SHEATHING^{a,b,c}

Fastener type ^d	Size (dia. or Screw #)	Minimum Required Brick-Tie Spacing (Vertical-Tie-Spacing/Horizontal-Tie-Spacing) (in./in.)					
		110 mph V _{ult}		130 mph V _{ult}		140 mph V _{ult}	
		Zone 5, Exposure C	Zone 5, Exposure D	Zone 5, Exposure C	Zone 5, Exposure D	Zone 5, Exposure C	Zone 5, Exposure D
Ring Shank	0.091	16/12, 12/16	12/12	12/12	--	--	--
	0.148	16/16	16/16	16/12, 12/16	16/12, 12/16	16/12, 12/16	12/12
Screws	#6	16/16	16/16	16/12, 12/16	16/12, 12/16	16/12, 12/16	12/12
	#8	24/16, 16/24	16/16	16/16	16/12, 12/16	16/12, 12/16	16/12, 12/16
	#10	24/16, 16/24	16/16	16/16	16/16	16/16	16/12, 12/16
	#14	24/16, 16/24	24/16, 16/24	24/16, 16/24	16/16	16/16	16/16

For SI: 1 inch = 25.4 mm, 1 mph = 0.447 m/s.

- This table is based on attachment of brick ties directly to wood structural panel sheathing only. Additional attachment of the brick tie to lumber framing is not required.
- Wood structural panels shall have a specific gravity of 0.42 or greater in accordance with NDS.
- Foam sheathing shall have a minimum compressive strength of 15 psf in accordance with ASTM C578 of ASTM C1289.
- Fasteners shall be sized such that the tip of the fastener passes completely through the wood structural panel sheathing by at least 1/4 inch.

Reason: The trend toward using more foam sheathing along with the use of advanced framing techniques in an effort to conserve energy has made it increasingly difficult to install wall cladding. Not only is the framing difficult to find under 2 inches of foam and building paper or house wrap, it may not even be present near corners and around openings because it may be completely masked by trim at corners and around windows.

The attachment of brick veneer brick-ties can similarly be a problem as the current attachment recommendations assume the brick ties are going to be nailed directly to those scarce framing members. The proposed table provided brick-tie attachment recommendations for attachment direct to a minimum 7/16 performance category wood structural panels. As the wood structural panel thickness does not permit the full use of the nail's shank, it is essential that either ring-shank nails or screws be used to keep the brick veneer in place. The above table provides this information. We think that while the use of ring shank fasteners will not be appropriate for every installation, the table provided is a tool that the mason may use if faced with the attachment of brick to a fully

sheathed, energy efficient home.

We ask the Committee to favorably consider this table for inclusion into the list of similar tables recently provided for the use of the builder, providing guidance for the installation of siding products over foam sheathing.

Cost Impact: Will increase the cost of construction

The proposed change will increase the cost of construction. The increase will be due to the use of ring-shank nails or screws over the more traditional nailed connections. The increase in construction costs can be partially offset by the fact that the builder will not have to locate the studs behind the various materials covering the studs (sheathing, foam, building paper) when attaching the brick ties, as attachment to the studs will not be required. The proposed solution will also eliminate the need to provide extra wall framing just to facilitate the attachment of the brick ties. The use of extra framing adds cost as well as reduces the thermal efficiency of the system.

**Report of Committee Action
Hearings**

Committee Action:

Disapproved

Committee Reason: The committee felt that Exposure B is needed and the cost impact should be quantified.

Assembly Action:

None

Public Comments

Public Comment 1:

Edward Keith, representing APA- The Engineered Wood Association (ed.keith@apawood.org); Borjen Yeh (borjen.yeh@apawood.org) requests Approve as Modified by this Public Comment.

Modify as follows:

R703.8.4 Anchorage. Masonry veneer shall be anchored to the supporting wall studs with corrosion-resistant metal ties embedded in mortar or grout and extending into the veneer a minimum of 1 1/2 inches (38 mm), with not less than 5/8-inch (15.9 mm) mortar or grout cover to outside face. Masonry veneer tie attachment and air space requirements shall conform to Table R703.8.4(1). For brick Masonry veneer tie attachment recommendations when brick ties are attached through any insulating sheathing, a maximum of 2" in thickness to a minimum of 7/16 performance category wood structural panel sheathing only, see Table R703.8.4(2).

TABLE R703.8.4(2)
REQUIRED BRICK TIE MINIMUM FASTENING REQUIREMENTS (VERTICAL TIE SPACING/ HORIZONTAL TIE SPACING)
FOR DIRECT APPLICATION OVER UP TO TWO INCHES OF FOAM TO MINIMUM 7/16 PERFORMANCE CATEGORY
WOOD STRUCTURAL PANEL SHEATHING^{a,b,c}

Fastener type ^d	Size (dia. or Screw #)	Required Brick-Tie Spacing (Vertical-Tie Spacing/Horizontal-Tie Spacing) (in./in.)											
		110 mph V Ultimate			115 mph V Ultimate			130 mph V Ultimate			140 mph V Ultimate		
		Zone 5, Exposure B	Zone 5, Exposure C	Zone 5, Exposure D	Zone 5, Exposure B	Zone 5, Exposure C	Zone 5, Exposure D	Zone 5, Exposure B	Zone 5, Exposure C	Zone 5, Exposure D	Zone 5, Exposure B	Zone 5, Exposure C	Zone 5, Exposure D
Ring Shank Nails	0.091	16/16, 16/12, 12/16, 12/12	16/12, 12/16, 1 2/12	12/12	16/16, 16/12, 12/16, 12/12	16/12, 12/16, 12/12	12/12	16/12, 12/16, 12/12	12/12	--	12/12	--	--
	0.148	24/16, 16/24, 16/16, 16/12, 12/16, 12/12	16/16, 1 6/12, 12/16, 12/12	16/16, 16/ 12, 12/16, 12/12	24/16, 16/24, 16/16, 16/12, 12/16, 12/12	16/16, 16/12, 12/16, 12/12	16/16, 16/12, 12/16, 12/12	16/16, 16/12, 12/16, 12/12	16/12, 12/16, 12/ 12	16/12, 12/16, 12/ 12	16/16, 16/12, 12/16, 12/12	16/12, 12/16, 12/ 12	12/12
Screws	#6	24/16, 16/24, 16/16, 16/12, 12/16, 12/12	16/16, 1 6/12, 12/16, 12/12	16/16, 16/ 12, 12/16, 12/12	24/16, 16/24, 16/16, 16/12, 12/16, 12/12	16/16, 16/12, 12/16, 12/12	16/16, 16/12, 12/16, 12/12	16/16, 16/12, 12/16, 12/12	16/12, 12/16, 12/ 12	16/12, 12/16, 12/ 12	16/16, 16/12, 12/16, 12/12	16/12, 12/16, 12/ 12	12/12
	#8	24/16,	24/16,	16/16,	24/16,	16/16,	16/16,	24/16,	16/16, 16/ 16/12,	16/12,	16/16,	16/12,	16/12,

	<u>16/24,</u> <u>16/16,</u> <u>16/12,</u> <u>12/16,</u> <u>12/12</u>	<u>16/24, 1</u> <u>6/16,</u> <u>16/12,</u> <u>12/16,</u> <u>12/12</u>	<u>16/12,</u> <u>12/16,</u> <u>12/12</u>	<u>16/24,</u> <u>16/16,</u> <u>16/12,</u> <u>12/16,</u> <u>12/12</u>	<u>16/12,</u> <u>12/16,</u> <u>12/12</u>	<u>16/12,</u> <u>12/16,</u> <u>12/12</u>	<u>16/24,</u> <u>16/16,</u> <u>16/12,</u> <u>12/16,</u> <u>12/12</u>	<u>12, 12/16,</u> <u>12/12</u>	<u>12/16, 12/</u> <u>12</u>	<u>16/12,</u> <u>12/16,</u> <u>12/12</u>	<u>12/16, 12/</u> <u>12</u>	<u>12/16, 12/12</u>
#10	<u>24/16,</u> <u>16/24,</u> <u>16/16,</u> <u>16/12,</u> <u>12/16,</u> <u>12/12</u>	<u>24/16,</u> <u>16/24, 1</u> <u>6/16,</u> <u>16/12,</u> <u>12/16,</u> <u>12/12</u>	<u>24/16,</u> <u>16/24, 16/</u> <u>16, 16/12,</u> <u>16/16,</u> <u>16/12,</u> <u>12/16,</u> <u>12/12</u>	<u>24/16,</u> <u>16/24,</u> <u>16/16,</u> <u>16/12,</u> <u>12/16,</u> <u>12/12</u>	<u>24/16,</u> <u>16/24,</u> <u>16/16,</u> <u>16/12,</u> <u>12/16,</u> <u>12/12</u>	<u>16/16,</u> <u>16/12,</u> <u>12/16,</u> <u>12/12</u>	<u>24/16,</u> <u>16/24,</u> <u>16/16,</u> <u>16/12,</u> <u>12/16,</u> <u>12/12</u>	<u>16/16, 16/</u> <u>12, 12/16,</u> <u>12/12</u>	<u>16/16, 16/</u> <u>12, 12/16,</u> <u>12/12</u>	<u>24/16,</u> <u>16/24,</u> <u>16/16,</u> <u>16/12,</u> <u>12/16,</u> <u>12/12</u>	<u>16/16, 16/</u> <u>12, 12/16,</u> <u>12/12</u>	<u>16/12,</u> <u>12/16,</u> <u>12/12</u>
#14	<u>24/16,</u> <u>16/24,</u> <u>16/16,</u> <u>16/12,</u> <u>12/16,</u> <u>12/12</u>	<u>24/16,</u> <u>16/24, 1</u> <u>6/16,</u> <u>16/12,</u> <u>12/16,</u> <u>12/12</u>	<u>24/16,</u> <u>16/24,</u> <u>16/16,</u> <u>16/12,</u> <u>12/16,</u> <u>12/12</u>	<u>24/16,</u> <u>16/24,</u> <u>16/16,</u> <u>16/12,</u> <u>12/16,</u> <u>12/12</u>	<u>24/16,</u> <u>16/24,</u> <u>16/16,</u> <u>16/12,</u> <u>12/16,</u> <u>12/12</u>	<u>24/16,</u> <u>16/24,</u> <u>16/16,</u> <u>16/12,</u> <u>12/16,</u> <u>12/12</u>	<u>24/16,</u> <u>16/24,</u> <u>16/16,</u> <u>16/12,</u> <u>12/16,</u> <u>12/12</u>	<u>24/16,</u> <u>16/24, 16/</u> <u>16, 16/12,</u> <u>12/12</u>	<u>16/16, 16/</u> <u>12, 12/16,</u> <u>12/12</u>	<u>24/16,</u> <u>16/24,</u> <u>16/16,</u> <u>16/12,</u> <u>12/16,</u> <u>12/12</u>	<u>16/16, 16/</u> <u>12, 12/16,</u> <u>12/12</u>	<u>16/16, 16/12,</u> <u>12/16, 12/12</u>

For SI: 1 inch = 25.4 mm, 1 mph = 0.447 m/s.

- a. This table is based on attachment of brick ties directly to wood structural panel sheathing only. Additional attachment of the brick tie to lumber framing is not required. The brick ties shall be permitted to be placed over any insulating sheathing, not to exceed 2" in thickness. Wood structural panel sheathing shall be a minimum 7/16 performance category. The table is based on a building height of 30 feet or less.
- b. Wood structural panels shall have a specific gravity of 0.42 or greater in accordance with NDS.
- c. Foam sheathing shall have a minimum compressive strength of 15 psf in accordance with ASTM C578 of ASTM C1289.
- d. Fasteners shall be sized such that the tip of the fastener passes completely through the wood structural panel sheathing by at least 1/4 inch.

Commenter's Reason: Opponents at the last committee action hearing asked us to return with a table that included Exposure B. The above reflects this change. In addition, all of the normally permitted fastener spacings were placed in the appropriate cells. Column headings were changed slightly to ensure a more consistent interpretation of the table. In addition, the results for the common 115 mph were also added at the request of the NAHB.

The Brick Industry Association, the Foam Industry and the NAHB worked with us to modify this proposal and we ask you to please vote to overturn the Committee's recommendation and put this valuable information into the IRC. A more robust cost impact statement, below, was requested by the committee.

COST IMPACT: The code change will slightly increase the cost of construction. While difficult to quantify, the cost increase will be due to the additional cost associated with the use of deformed shank nails or screws for the attachment of brick ties. the additional cost increase is offset by a number of factors that could easily offset the extra cost.

- The ease of construction as the siding contractor can apply the fasteners without having to worry about hitting a stud behind building paper, structural sheathing, and sometimes even insulating sheathing. This can greatly speed up the installation process. It is easy to use any attachment pattern when you don't have to worry about hitting ant framing hidden behind.
- With the use of advanced framing techniques, additional framing is often needed to provide for siding attachment, particularly at windows and doors. (the first attachment point at the end f the lap siding is especially difficult to accomplish as trim boards often cover up the framing, providing no nail base for the ends of the boards.) This additional framing is expensive, labor consuming, and reduces the effectiveness of the advanced .
- The reduced penetration into sheathing 3/8" to 7/16" vs. 1-1/4" to 1-1/2" will often permit the use of a shorter nail, especially when foam sheathing is used behind the siding. (E.g., plywood lap siding over 2 inches of foam sheathing would require the use of a 4" nail to get the required 1-1/2" penetration into the framing, but only a 3-1/2 inch fastener for attachment into sheathing.)
- The additional fasteners required to anchor the siding to wood structural sheathing provides the siding with additional attachment points thus better holding the siding and foam sheathing in place when exposed to high wind events, minimizing the loss of the siding products.

Based on Housewyse.com estimates, the increase in building costs is about \$0.07 per square foot, which can be offset at least partially by those factors mentioned above. We ask you to overturn the Committee's recommendation and put this valuable table into the IRC.

Final Action Results

RB303-16

AMPC1

[←BACK](#)

Code Change No: **RB305-16**

Original Proposal

Section: R703.11.2, R703.11.2 (New), R703.11.2.1, R703.11.2.2, R703.11.2.3

Proponent: Jay Crandell, P.E., ARES Consulting, representing Foam Sheathing Committee of the American Chemistry Council

Revise as follow:

R703.11.2 Foam Installation over foam plastic sheathing. ~~Vinyl~~ Where vinyl siding ~~and/or~~ insulated vinyl siding ~~used with~~ is installed over foam plastic sheathing, the vinyl siding shall comply with Section R703.11 and shall be installed in accordance with Sections R703.11.1 and R703.3.3. The foam plastic sheathing and its attachment shall have a design wind pressure resistance complying with Section ~~R703.11.2.1~~R316.8. Where design is required in accordance with Figure R301.2(4)~~B~~, R703.11.2.2 or R703.11.2.3 the foam plastic sheathing and vinyl siding installation shall comply with Section 705.2 of ICC 600.

Exceptions-Exceptions:

1. Where the foam plastic sheathing is applied directly over wood structural panels, fiberboard, gypsum sheathing or other *approved* backing capable of independently resisting the design wind pressure, the vinyl siding shall be installed in accordance with Sections R703.11.1 and R703.3.3, and the foam plastic sheathing shall not be required to comply with Section ~~R703.11.1~~R316.8.
2. Where the vinyl siding manufacturer's product specifications provide an approved design wind pressure rating for installation over foam plastic sheathing, use of this design wind pressure rating shall be permitted and the siding shall be installed in accordance with the manufacturer's instructions.

Delete without substitution:

~~R703.11.2.1 Basic wind speed not exceeding 115 miles per hour and Exposure Category B.~~ Where the ultimate design wind speed does not exceed 115 miles per hour (51 m/s), the exposure category is B and gypsum board, gypsum panel product or equivalent is installed on the side of the wall opposite the foam plastic sheathing, the minimum siding fastener penetration into wood framing shall be 1-1/4 inches (32 mm) using minimum 0.120-inch-diameter (3 mm) nail (shank) with a minimum 0.313-inch-diameter head, 16 inches (406 mm) on center. The foam plastic sheathing shall be minimum 1/2-inch-thick (12.7 mm) (nominal) extruded polystyrene in accordance with ASTM C 578, 1/2-inch-thick (12.7 mm) (nominal) polyisocyanurate in accordance with ASTM C 1289 or 1-inch-thick (25 mm) (nominal) expanded polystyrene in accordance with ASTM C 578.

~~R703.11.2.2 Basic wind speed exceeding 115 miles per hour or Exposure Categories C and D.~~ Where the ultimate design wind speed exceeds 115 miles per hour (51 m/s), the exposure category is C or D, or all conditions of Section R703.11.2.1 are not met, the adjusted design pressure rating for the assembly shall meet or exceed the loads listed in Table R301.2(2) adjusted for height and exposure using Table R301.2(3). The design wind pressure rating of the vinyl siding for installation over solid sheathing as provided in the vinyl siding manufacturer's product specifications shall be adjusted for the following wall assembly conditions:

1. ~~For wall assemblies with foam plastic sheathing on the exterior side and gypsum wall board, gypsum panel product or equivalent on the interior side of the wall, the vinyl siding's design wind pressure rating shall be multiplied by 0.39.~~
2. ~~For wall assemblies with foam plastic sheathing on the exterior side and without gypsum wall board, gypsum panel product or equivalent on the interior side of wall, the vinyl siding's design wind pressure rating shall be multiplied by 0.27.~~

R703.11.2.3 Manufacturer specification. ~~Where the vinyl siding manufacturer's product specifications provide an approved design wind pressure rating for installation over foam plastic sheathing, use of this design wind pressure rating shall be permitted and the siding shall be installed in accordance with the manufacturer's instructions.~~

Reason: The provisions for application of vinyl siding with foam plastic sheathing are revised to coordinate with changes made last code cycle to address foam sheathing wind pressure resistance in Section R316.8 and to reference the clarified attachment requirements in Section R703.11.1 and R703.3.3. Also, the section is revised to require that the foam sheathing and its attachment are rated for wind pressure resistance per Section R316.8 such that the adjustment factors and additional conditions in Sections R703.11.2.1 and R703.11.2.2 are no longer necessary (these sections are deleted). In addition, Section R703.11.2.3 is deleted because it is included as exception #2 in the revised Section R703.11.2. Finally, guidance specifically addressing this topic for high wind conditions (where design is required in the IRC) have been added to the ICC 600 reference standard. Thus, these new provisions are coordinated in this proposal to ensure appropriate use and limitations for applications of vinyl siding and foam sheathing. Overall, these provisions will simplify the code, its enforcement, and its use while maintaining intended levels of performance.

Cost Impact: Will not increase the cost of construction
This proposal simplifies the code and compliance while maintaining equivalent performane with no cost impact.

Report of Committee Action Hearings
--

Committee Action:

Approved as Modified

Modify as follows:

R703.11.2 Installation over foam plastic sheathing. ~~Where vinyl siding or insulated vinyl siding is installed over foam plastic sheathing, the vinyl siding shall comply with Section R703.11 and shall be installed in accordance with Sections R703.11.1 and R703.3.3. The foam plastic sheathing and its attachment shall have a design wind pressure resistance complying with Section R316.8. Where design is required in accordance with Figure R301.2(4)B, the foam plastic sheathing and vinyl siding installation shall comply with Section 705.2 of ICC 600 Table R703.11.2.~~

Exceptions:

1. ~~Where the foam plastic sheathing is applied directly over wood structural panels, fiberboard, gypsum sheathing or other *approved* backing capable of independently resisting the design wind pressure, the vinyl siding shall be installed in accordance with Sections R703.11.1 and R703.3.3, and the foam plastic sheathing shall not be required to comply with Section R316.8.~~
2. Where the vinyl siding manufacturer's product specifications provide an approved design wind pressure rating for installation over foam plastic sheathing, use of this design wind pressure rating shall be permitted and the siding shall be installed in accordance with the manufacturer's instructions.
3. Where the foam plastic sheathing and its attachment has a design wind pressure resistance complying with Sections R316.8 and R301.2.1, the vinyl siding shall be installed in accordance with Sections R703.11.1 and R703.3.3.

**TABLE R703.11.2
ADJUSTED MINIMUM DESIGN WIND PRESSURE REQUIREMENT FOR VINYL SIDING**

<u>Ultimate Design Wind Speed (mph)</u>	<u>Adjusted Minimum Design Wind Pressure (ASD) (psf)^{a,b}</u>					
	<u>Case 1: With interior gypsum wallboard^c</u>			<u>Case 2: Without interior gypsum wallboard^c</u>		
	<u>Exposure</u>			<u>Exposure</u>		
	<u>B</u>	<u>C</u>	<u>D</u>	<u>B</u>	<u>C</u>	<u>D</u>
110	-44.0	-61.6	-73.1	-62.9	-88.1	-104.4
115	-49.2	-68.9	-81.7	-70.3	-98.4	-116.7
120	-51.8	-72.5	-86.0	-74.0	-103.6	-122.8
130	-62.2	-87.0	-103.2	-88.8	-124.3	-147.4
>130	Not Allowed ^d					

For SI: 1 mile per hour = 0.447 m/s, 1 pound per square foot = 0.0479 kPa

a. Linear interpolation is permitted.

b. The table values are based on a maximum 30-ft mean roof height, and effective wind area of 10 ft², Wall Zone 5 (corner), and the ASD design wind pressure from Table R301.2(2) multiplied by the following adjustment factors: 2.6 (Case 1) and 3.7 (Case 2) for wind speeds less than 130 mph and 3.7 (Case 2) for wind speeds greater than 130 mph.

c. Gypsum wallboard, gypsum panel product or equivalent.

d. For the indicated wind speed condition, foam sheathing only on the exterior of frame walls with vinyl siding is not allowed unless the vinyl siding complies with an adjusted minimum design wind pressure requirement as determined in accordance with footnote b and the wall assembly is capable of resisting an impact without puncture at least equivalent to that of a wood frame wall with minimum 7/16" OSB sheathing as tested in accordance with ASTM E1886.

Committee Reason: This proposal improves and simplifies the installation requirements to comply with the latest industry standards. The modification further simplifies by eliminating the modification factor by providing a table to determine design wind pressures.

Assembly Action

None

Final Action Results

RB305-16

AM

[←BACK](#)

Code Change No: **RB307-16**

Original Proposal

Section: R703.14, R703.14.1, R703.14.1.1, R703.14.1.2, R703.14.3 (New)

Proponent: Marcelo Hirschler, representing GBH International (gbhint@aol.com)

Add new text as follows:

R703.14 Polypropylene siding. Polypropylene siding shall be certified and labeled as conforming to the requirements of ASTM D 7254 by an approved quality control agency.

R703.14.1 Polypropylene siding and accessories. Polypropylene siding and accessories shall be installed in accordance with manufacturer's installation instructions.

R703.14.1.1 Installation. Polypropylene siding shall be installed over and attached to wood structural panel sheathing with minimum thickness of $7/16$ inch (11.1 mm), or other substrate, composed of wood or wood-based material and fasteners having equivalent withdrawal resistance.

R703.14.1.2 Fastener requirements. Unless otherwise specified in the approved manufacturer's instructions, nails shall be corrosion resistant, with a minimum 0.120-inch (3 mm) shank and minimum 0.313-inch (8 mm) head diameter. Nails shall be a minimum of $1\ 1/4$ inches (32 mm) long or as necessary to penetrate sheathing or substrate not less than $3/4$ inch (19.1 mm). Where the nail fully penetrates the sheathing or nailable substrate, the end of the fastener shall extend not less than $1/4$ inch (6.4 mm) beyond the opposite face of the sheathing or substrate. Staples are not permitted.

R703.14.1.3 Flame spread index The certification of the flame spread index shall be accompanied by a test report stating that all portions of the test specimen ahead of the flame front remained in position during the test in accordance with ASTM E84 or UL 723.

Reason: The reason for this proposal is that polypropylene is a material that exhibits much poorer fire performance than other siding materials such as wood (e.g. cedar), vinyl (PVC) or aluminum. This proposal adds the requirements contained in the 2015 IBC, which have not been altered in the current code cycle. ASTM D7254 requires polypropylene siding to comply with a flame spread index (FSI) of 200 when tested in the ASTM E84 test. That is an appropriate requirement since it is consistent with the performance of wood siding materials in the same test. Unfortunately, polypropylene has the tendency to melt and flow away from the flame, while vinyl and wood do not. ASTM E84 warns (in section 1.4) that, when materials that melt or delaminate are tested, they will generate inadequately low FSI values.

The flame spread index in accordance with ASTM E84 must be assessed with a test specimen that remains in position during the test ahead of the flame front because of the well-known tendency for polypropylene to melt and drip. This tendency of polypropylene to melt and drip has been recognized by the IBC when it incorporated the requirements in section 1404.12.1 (for polypropylene siding) and in section 803.12 (for polypropylene used as interior finish). In the case of polypropylene siding the IBC has language consistent with the proposed to the IRC for the siding. In the case of polypropylene as interior finish, the IBC does not allow it to be tested to ASTM E84 but requires the use of the room-corner test (NFPA 286). The proposal does not recommend using the room-corner test for siding in the IRC: that is unnecessary. With the proposed provisions, enough safety is provided that polypropylene siding can be used safely in the IRC.

The data below shows fire tests on two different PP siding materials and on a wood (cedar) siding using the cone calorimeter, ASTM E1354, at an incident heat flux of 25 kW/m², as well as some material tests on vinyl (PVC) and on a fire retarded polypropylene. The data indicates the problem with some polypropylene materials used for siding.

Siding tests (ASTM E1354)

Wood (cedar) siding: peak heat release rate 309 kW/m² - effective heat of combustion: 13 MJ/kg

Polypropylene siding 1: peak heat release rate 546 kW/m² - effective heat of combustion: 25 MJ/kg

Polypropylene siding 2: peak heat release rate 878 kW/m² - effective heat of combustion: 32 MJ/kg

Material tests (ASTM E1354)

Vinyl (PVC): peak heat release rate 190 kW/m² - effective heat of combustion: 9 MJ/kg

Fire retarded polypropylene: peak heat release rate 200 kW/m² - effective heat of combustion: 25 MJ/kg

The data below shows fire tests using the ASTM E84 test on materials that cause no flaming on the floor ahead of the flame front, as recommended in this proposal. The data show that polypropylene can be made so that it meets the requirements indicated in the proposal, in the ASTM E84 test without melting, and perform just like PVC (vinyl) or wood products.

Vinyl (PVC): ASTM E84 FSI 10

Fire retarded polypropylene: ASTM E84 FSI 50

Western red cedar: ASTM E84 FSI 70

Douglas fir: ASTM E84 FSI 70-100

Western white pine: ASTM E84 FSI 75

For information, the IBC 2015 contains the following section:

1404.12.1 Flame spread index. The certification of the flame spread index shall be accompanied by a test report stating that all portions of the test specimen ahead of the flame front remained in position during the test in accordance with ASTM E 84 or UL 723.

Also, for information, section 1.4 of ASTM E84 reads as follows:

"1.4 Testing of materials that melt, drip, or delaminate to such a degree that the continuity of the flame front is destroyed, results in low flame spread indices that do not relate directly to indices obtained by testing materials that remain in place."

Cost Impact: Will increase the cost of construction

The added requirements are consistent with those in the IBC and with requirements to ensure safe use of polypropylene siding.

Report of Committee Action Hearings

Committee Action:

Approved as Modified

Modify as follows:

R703.14 Polypropylene siding. Polypropylene siding shall be certified and labeled as conforming to the requirements of ASTM D 7254, and those of Section R703.14.2 or Section R703.14.3, by an approved quality control agency.

~~R703.14.1.3~~ **R703.14.3 Flame spread index** *No change to text.*

Committee Reason: The committee approved this proposal based on the proponents published reason statement. The modification replicates the IBC language for polypropylene siding.

Assembly Action

None

Final Action Results

RB307-16

AM

[←BACK](#)

Code Change No: RB308-16

Original Proposal

Section: R703.15.1, R703.15.2

Proponent: Jay Crandell, P.E., ARES Consulting, representing Foam Sheathing Committee of the American Chemistry Council

Revise as follows:

TABLE R703.15.1
CLADDING MINIMUM FASTENING REQUIREMENTS FOR DIRECT ATTACHMENT OVER FOAM PLASTIC SHEATHING TO SUPPORT CLADDING WEIGHT^a

CLADDING FASTENER THROUGH FOAM SHEATHING	CLADDING FASTENER TYPE AND MINIMUM SIZE ^b	CLADDING FASTENER VERTICAL SPACING (inches)	MAXIMUM THICKNESS OF FOAM SHEATHING ^c (inches)							
			16" o.c. Fastener Horizontal Spacing				24" o.c. Fastener Horizontal Spacing			
			Cladding Weight:				Cladding Weight:			
			3 psf	11 psf	18 psf	25 psf	3 psf	11 psf	18 psf	25 psf
Wood Framing (minimum 1 ¹ / ₄ -inch penetration)	0.113" diameter nail	6	<u>2.00</u>	<u>1.45</u>	<u>0.75</u>	DR	<u>2.00</u>	<u>0.85</u> 75	<u>DR</u>	DR
		8	<u>2.00</u>	<u>1.00</u>	<u>DR</u>	DR	<u>2.00</u>	<u>0.55</u>	<u>DR</u>	DR
		12	<u>2.00</u>	<u>0.55</u>	<u>DR</u>	DR	<u>1.85</u> 2	DR	<u>DR</u>	DR
	0.120" diameter nail	6	<u>3.00</u>	<u>1.70</u> 5	<u>0.90</u>	<u>0.55</u>	<u>3.00</u>	<u>1.05</u> 75	<u>0.50</u>	DR
		8	<u>3.00</u>	<u>1.20</u>	<u>0.60</u>	DR	<u>3.00</u>	<u>0.70</u> 5	<u>DR</u>	DR
		12	<u>3.00</u>	<u>0.70</u> 5	<u>DR</u>	DR	<u>2.15</u>	DR	<u>DR</u>	DR
	0.131" diameter nail	6	<u>4.00</u>	<u>2.15</u>	<u>1.20</u>	<u>0.75</u>	<u>4.00</u>	<u>1.35</u>	<u>0.70</u>	DR
		8	<u>4.00</u>	<u>1.55</u>	<u>0.80</u>	<u>DR</u> 0.5	<u>4.00</u>	<u>0.90</u> 75	<u>DR</u>	DR
		12	<u>4.00</u>	<u>0.90</u> 75	<u>DR</u>	DR	<u>2.70</u>	<u>0.50</u>	<u>DR</u>	DR
	0.162" diameter nail	6	<u>4.00</u>	<u>3.55</u> 4	<u>2.05</u>	<u>1.40</u> 5	<u>4.00</u>	<u>2.25</u>	<u>1.25</u>	<u>0.80</u> 4
		8	<u>4.00</u>	<u>2.55</u> 3	<u>1.45</u>	<u>0.95</u> 4	<u>4.00</u>	<u>1.60</u> 5	<u>0.85</u>	<u>0.50</u> 75
		12	<u>4.00</u>	<u>1.60</u> 2	<u>0.85</u>	<u>0.50</u> 75	<u>4.00</u>	<u>0.95</u> 4	<u>DR</u>	DR

For SI: 1 inch = 25.4 mm, 1 pound per square foot = 0.0479 kPa, 1 pound per square inch = 6.895 kPa.

DR = Design required.

o.c. = on center

a. Wood framing shall be Spruce-pine-fir or any wood species with a specific gravity of 0.42 or greater in accordance with AWC NDS.

b. Nail fasteners shall comply with ASTM F 1667, except nail length shall be permitted to exceed ASTM F 1667 standard lengths.

c. Foam sheathing shall have a minimum compressive strength of 15 psi in accordance with ASTM C 578 or ASTM C 1289.

TABLE R703.15.2
FURRING MINIMUM FASTENING REQUIREMENTS FOR APPLICATION OVER FOAM PLASTIC SHEATHING TO
SUPPORT CLADDING WEIGHT^{a, b}

FURRING MATERIAL	FRAMING MEMBER	FASTENER TYPE AND MINIMUM SIZE	MINIMUM PENETRATION INTO WALL FRAMING (inches)	FASTENER SPACING IN FURRING (inches)	MAXIMUM THICKNESS OF FOAM SHEATHING ^d (inches)								
					16" o.c. Furring ^e				24" o.c. Furring ^e				
					Siding Weight:				Siding Weight:				
					3 psf	11 psf	18 psf	25 psf	3 psf	11 psf	18 psf	25 psf	
Minimum 1x Wood Furring ^c	Minimum 2x Wood Stud	0.131" diameter nail	1 1/4	8	4.00	2.45	1.45	0.95/4	4.00	1.60/5	0.85	DR	
				12	4.00	1.60/5	0.85	DR	4.00/3	0.95/4	DR	DR	
				16	4.00	1.10	DR	DR	3.05	0.60/5	DR	DR	
		0.162" diameter nail	1 1/4	8	4.00	4.00	2.45	1.60/5	4.00	2.75	1.45	0.85/75	DR
				12	4.00	2.75	1.45	0.85/75	4.00	1.65	0.75	DR	
				16	4.00	1.90/5	0.95	DR	4.00	1.05	DR	DR	
	No.10 wood screw	1	12	4.00	2.30	1.20	0.70/5	4.00	1.40/5	0.60	DR		
			16	4.00	1.65	0.75	DR	4.00	0.90/4	DR	DR		
			24	4.00	0.90/4	DR	DR	2.85/3	DR	DR	DR		
	1/4" lag screw	1 1/2	12	4.00	2.6/53	1.50	0.90/4	4.00	1.65/2	0.80	DR/0.5		
			16	4.00	1.95	0.95	0.50/DR	4.00	1.10/5	DR	DR		
			24	4.00	1.10/5	DR	DR	3.25/4	0.50/75	DR	DR		

For SI: 1 inch = 25.4 mm, 1 pound per square foot = 0.0479 kPa, 1 pound per square inch = 6.895 kPa.

DR = Design required.

o.c. = on center

- Wood framing and furring shall be Spruce-pine-fir or any wood species with a specific gravity of 0.42 or greater in accordance with AWC NDS.
- Nail fasteners shall comply with ASTM F 1667, except nail length shall be permitted to exceed ASTM F 1667 standard lengths.
- Where the required cladding fastener penetration into wood material exceeds 3/4 inch and is not more than 1 1/2 inches, a minimum 2x wood furring or an approved design shall be used.
- Foam sheathing shall have a minimum compressive strength of 15 psi in accordance with ASTM C 578 or ASTM C 1289.
- Furring shall be spaced not more than 24 inches on center, in a vertical or horizontal orientation. In a vertical orientation, furring shall be located over wall studs and attached with the required fastener spacing. In a horizontal orientation, the indicated 8-inch and 12-inch fastener spacing in furring shall be achieved by use of two fasteners into studs at 16 inches and 24 inches on center, respectively.

Reason: This proposal updates the table values to a consistent rounding approach by rounding the values down to the nearest 0.05" to address actual thicknesses of foam sheathing materials that often vary from nominal dimensions such as 0.5", 1", 1.5" 2", 3" and 4" as used in the existing table. In addition, an 18psf cladding weight category was added to accommodate common application of adhered veneers as requested by the brick industry. All of the values were evaluated using the same analysis approach used to derive the existing tables. In addition, the foam thickness remains capped at 4 inches in all cases and at 2 inches for 0.113-in diameter nails and 3 inches for 0.120-in diameter nails as was done in the existing table for practical reasons.

Cost Impact: Will not increase the cost of construction

The proposal adds an additional option (18 psf cladding weight) and does not increase cost.

**Report of Committee Action
Hearings**

Committee Action:

Approved as Submitted

Committee Reason: The committee approved this proposal based on the proponents published reason statement.

Assembly Action:

None

Final Action Results

RB308-16

AS

[←BACK](#)

Code Change No: RB309-16

Original Proposal

Section: R703.16.1, R703.16.2

Proponent: Jay Crandell, P.E., ARES Consulting, representing Foam Sheathing Committee of the American Chemistry Council

Revise as follows:

TABLE R703.16.1
CLADDING MINIMUM FASTENING REQUIREMENTS FOR DIRECT ATTACHMENT OVER FOAM PLASTIC SHEATHING TO SUPPORT CLADDING WEIGHT^a

CLADDING FASTENER THROUGH FOAM SHEATHING INTO:	CLADDING FASTENER TYPE AND MINIMUM SIZE ^b	CLADDING FASTENER VERTICAL SPACING (inches)	MAXIMUM THICKNESS OF FOAM SHEATHING ^c (inches)								
			16" o.c. Fastener Horizontal Spacing				24" o.c. Fastener Horizontal Spacing				
			Cladding Weight:				Cladding Weight:				
			3 psf	11 psf	<u>18 psf</u>	25 psf	3 psf	11 psf	<u>18 psf</u>	25 psf	
Steel Framing (minimum penetration of steel thickness + 3 threads)	No. 8 screw into 33 mil steel or thicker	6	<u>3.00</u>	2.95	<u>2.20</u>	1.45	<u>3.00</u>	<u>2.35</u>	<u>1.25</u>	DR	
		8	<u>3.00</u>	<u>2.55</u>	<u>1.60</u>	0.605	<u>3.00</u>	1.805	<u>DR</u>	DR	
		12	<u>3.00</u>	1.805	<u>DR</u>	DR	<u>3.00</u>	0.6575	<u>DR</u>	DR	
	No. 10 screw into 33 mil steel	6	<u>4.00</u>	<u>3.50</u>	<u>2.70</u>	<u>1.952</u>	<u>4.00</u>	2.903	<u>1.70</u>	<u>0.55</u>	
		8	<u>4.00</u>	<u>3.10</u>	<u>2.05</u>	1.00	<u>4.00</u>	<u>2.25</u>	<u>0.70</u>	DR	
		12	<u>4.00</u>	<u>2.25</u>	<u>0.70</u>	DR	<u>3.70</u>	<u>1.05</u>	<u>DR</u>	DR	
		No. 10 screw into 43 mil steel or thicker	6	<u>4.00</u>	<u>4.00</u>	<u>4.00</u>	<u>3.60</u>	<u>4.00</u>	<u>4.00</u>	<u>3.45</u>	<u>2.70</u>
			8	<u>4.00</u>	<u>4.00</u>	<u>3.70</u>	3.002	<u>4.00</u>	<u>3.85</u>	<u>2.80</u>	1.805
			12	<u>4.00</u>	<u>3.85</u>	<u>2.80</u>	<u>1.805</u>	<u>4.00</u>	<u>3.05</u>	<u>1.50</u>	DR

For SI: 1 inch = 25.4 mm, 1 mil = 0.0254 mm, 1 pound per square foot = 0.0479 kPa, 1 pound per square inch = 6.895 kPa.

DR = Design required.

o.c. = on center

a. Steel framing shall be minimum 33 ksi steel for 33 mil and 43 mil steel, and 50 ksi steel for 54 mil steel or thicker.

b. Screws shall comply with the requirements of ASTM C 1513.

c. Foam sheathing shall have a minimum compressive strength of 15 psi in accordance with ASTM C 578 or ASTM C 1289.

**TABLE R703.16.2
FURRING MINIMUM FASTENING REQUIREMENTS FOR APPLICATION OVER FOAM PLASTIC SHEATHING TO
SUPPORT CLADDING WEIGHT^a**

FURRING MATERIAL	FRAMING MEMBER	FASTENER TYPE AND MINIMUM SIZE ^b	MINIMUM PENETRATION INTO WALL FRAMING (inches)	FASTENER SPACING IN FURRING (inches)	MAXIMUM THICKNESS OF FOAM SHEATHING ^d (inches)							
					16" o.c. Furring				24" o.c. Furring			
					Cladding Weight:				Cladding Weight:			
					3 psf	11 psf	18 psf	25 psf	3 psf	11 psf	18 psf	25 psf
Minimum 33 mil Steel Furring or Minimum 1 x Wood Furring ^c	33 mil Steel Stud	No. 8 screw	Steel thickness + 3 threads	12	3.00	1.80	DR	DR	3.00	0.65	DR	DR
				16	3.00	1.00	DR	DR	2.85	DR	DR	DR
				24	2.85	DR	DR	DR	2.20	DR	DR	DR
		No. 10 screw	Steel thickness + 3 threads	12	4.00	2.25	0.70	DR	3.70	1.05	DR	DR
				16	3.85	1.45	DR	DR	3.40	DR	DR	DR
				24	3.40	DR	DR	DR	2.70	DR	DR	DR
	43 mil or thicker Steel Stud	No. 8 Screw	Steel thickness + 3 threads	12	3.00	1.80	DR	DR	3.00	0.65	DR	DR
				16	3.00	1.00	DR	DR	2.85	DR	DR	DR
				24	2.85	DR	DR	DR	2.20	DR	DR	DR
		No. 10 screw	Steel thickness + 3 threads	12	4.00	3.85	2.80	1.80	4.00	3.05	1.50	DR
				16	4.00	3.30	1.95	0.60	4.00	2.25	DR	DR
				24	4.00	2.25	DR	DR	4.00	0.65	DR	DR

For SI: 1 inch = 25.4 mm, 1 mil = 0.0254 mm, 1 pound per square foot = 0.0479 kPa, 1 pound per square inch = 6.895 kPa.

DR = Design required.

o.c. = on center

a. Wood furring shall be Spruce-pine-fir or any softwood species with a specific gravity of 0.42 or greater. Steel furring shall be minimum 33 ksi steel. Steel studs shall be minimum 33 ksi steel for 33mil and 43 mil thickness, and 50 ksi steel for 54 mil steel or thicker.

b. Screws shall comply with the requirements of ASTM C 1513.

c. Where the required cladding fastener penetration into wood material exceeds $\frac{3}{4}$ inch and is not more than $1\frac{1}{2}$ inches, a minimum 2-inch nominal wood furring or an approved design shall be used.

d. Foam sheathing shall have a minimum compressive strength of 15 psi in accordance with ASTM C 578 or ASTM C 1289.

e. Furring shall be spaced not more than 24 inches (610 mm) on center, in a vertical or horizontal orientation. In a vertical orientation, furring shall be located over wall studs and attached with the required fastener spacing. In a horizontal orientation, the indicated 8-inch and 12-inch fastener spacing in furring shall be achieved by use of two fasteners into studs at 16 inches and 24 inches on center, respectively.

Reason: This proposal updates the table values to a consistent rounding approach by rounding the values down to the nearest 0.05" to address actual thicknesses of foam sheathing materials that often vary from nominal dimensions such as 0.5", 1", 1.5", 2", 3", and 4" as used in the existing table. In addition, an 18 psf cladding weight category was added to accommodate common application of adhered veneers as requested by the brick industry. All of the values were evaluated using the same analysis approach used to derive the existing table values. In addition, the foam sheathing thickness remains capped at 4 inches in all cases and at 3 inches for #8 screws as was done in the existing table for practical reasons.

Cost Impact: Will not increase the cost of construction
This proposal adds an additional option (18 psf cladding weight) and does not increase cost.

**Report of Committee Action
Hearings**

Committee Action: **Approved as Submitted**

Committee Reason: The committee approved this proposal based on the proponents published reason statement.

Assembly Action: **None**

Final Action Results

RB309-16 AS

[←BACK](#)

Code Change No: **RB310-16**

Original Proposal

Section: R802, R802.2, R802.3, R802.3 (New), R802.3.1, R802.3.2, R802.3.3, R802.4, R802.4 (New), R802.4.3 (New), R802.4.4 (New), R802.4.6 (New), R802.5, R802.5 (New), R802.5.1, R802.5.2.2 (New)

Proponent: Charles Bajnai, representing Chesterfield County, VA (bajnaic@chesterfield.gov)

Revise as follows:

SECTION R802 WOOD ROOF FRAMING

R802.2 Design and construction. ~~The framing details required in Section R802 apply roof and ceiling assembly shall provide a continuous tie across the structure to roofs having a minimum slope of three units vertical in 12 units horizontal (25-percent slope) or greater prevent roof thrust from being applied to the supporting walls. Roof ceilings~~ The assembly shall be designed and constructed in accordance with the provisions of this chapter and Figures R606.11(1), R606.11(2) and R606.11(3) or in accordance with AWC NDS. ~~Components of roof ceilings shall be fastened in accordance with Table R602.3(1).~~

R802.3 Ridge. A ridge board used to connect opposing rafters shall be not less than 1 inch (nominal) thickness and not less in depth than the cut end of the rafter. Where ceiling joist or rafter ties do not provide a continuous tie across the structure, a ridge beam shall be provided and supported on each end by a wall or girder.

R802.4 Rafters. Rafters shall be in accordance with this section.

R802.5 R802.4.1 Allowable rafter spans Rafter size. ~~Spans for rafters Rafters shall be sized based on the rafter spans in accordance with Tables R802.5.1(1) through R802.5.1(8) R802.4.1(8).~~ Rafter spans shall be measured along the horizontal projection of the rafter. For other grades and species and for other loading conditions, refer to the AWC STJR. ~~The span of each rafter shall be measured along the horizontal projection of the rafter.~~

R802.3 R802.4.2 Framing details. Rafters shall be framed not more than 1½-inch (38 mm) offset from each other to a ridge board or directly opposite from each other with a collar tie, gusset plate ~~as a tie or ridge strap.~~ Ridge board Rafters shall be not less than 1-inch (25 mm) nominal thickness and not less nailed to the top wall plates in depth than the cut end of the rafter. At valleys and hips there shall be a valley or hip rafter not less than 2-inch (51 mm ~~accordance with Table R602.3(1)~~ nominal thickness and not less in depth than the cut end of the rafter. Hip and valley rafters shall be supported at the ridge by a brace to a bearing partition or be designed to carry and distribute the specific load at that point. ~~Where unless the roof pitch assembly is less than three units vertical in 12 units horizontal (25-percent slope), structural members that support rafters and ceiling joists, such as ridge beams, hips and valleys, shall be designed as beams required to comply with the uplift requirements of Section R802.11.~~

R802.4.3 Hips and Valleys. Hip and valley rafters shall be not less than 2-inch nominal thickness and not less in depth than the cut end of the rafter. Hip and valley rafters shall be supported at the ridge by a brace to a bearing partition or be designed to carry and distribute the specific load at that point.

R802.4.4 Rafter supports. ~~Where the roof pitch is less than 3 units vertical in 12 units horizontal (25-percent slope), structural members that support rafters, such as ridges, hips and valleys, shall be~~

designed as beams.

R802.5.1 R802.4.5 Purlins. Installation of purlins to reduce the span of rafters is permitted as shown in Figure ~~R802.5.1~~R802.4.5. Purlins shall be sized not less than the required size of the rafters that they support. Purlins shall be continuous and shall be supported by 2-inch by 4-inch (51 mm by 102 mm) braces installed to bearing walls at a slope not less than 45 degrees (0.785 rad) from the horizontal. The braces shall be spaced not more than 4 feet (1219 mm) on center and the unbraced length of braces shall not exceed 8 feet (2438 mm).

R802.4.6 Collar ties. Where collar ties are used to connect opposing rafters, they shall be located in the upper third of the attic space and fastened in accordance with Table R602.3(1). Collar ties shall be not less than 1 inch by 4 inch (nominal), spaced not more than 4 feet on center. Ridge straps shall be permitted to replace collar ties.

R802.5 Ceiling joists. Ceiling joists shall be continuous across the structure or securely joined where they meet over interior partitions in accordance with Table R802.5.2.

R802.4 R802.5.1 Allowable ceiling Ceiling joist spans size. Spans for ceiling Ceiling joists shall be sized based on the joist spans in accordance with Tables ~~R802.4(1)~~R802.5.1(1) and ~~R802.4(2)~~R802.5.1(2). For other grades and species and for other loading conditions, refer to the AWC STJR-.

R802.3.1 R802.5.2 Ceiling joist and rafter connections. ~~Ceiling Where ceilings~~ joists and run parallel to rafters, they shall be nailed connected to each other in accordance with Table R802.5.1(9), and the rafter shall be nailed to rafters at the top wall plate in accordance with Table ~~R602.3(1)~~R802.5.2. Ceiling joists shall be continuous or securely joined in accordance with Table R802.5.1(9) where they meet over interior partitions and are nailed to adjacent rafters to provide a continuous tie across the building where such joists are parallel to the rafters.

Where ceiling joists are not connected to the rafters at the top wall plate, joists connected higher in the attic shall be installed as rafter ties, or rafter ties they shall be installed to provide a continuous tie in the bottom third of the rafter height in accordance with Figure R802.4.5. and Table R802.5.2.

Where the ceiling joists are installed above the bottom third of the rafter height, the ridge shall be designed as a beam.

Where ceiling joists do not run parallel to rafters, rafter ties shall be installed. Rafter ties shall be not less than 2 inches by 4 inches (51 mm by 102 mm) (nominal), installed in accordance with the connection requirements in Table R802.5.1(9), or connections of equivalent capacities shall be provided. Where ceiling joists or rafter ties are not provided, the ridge formed by these rafters shall be supported by a wall or girder designed in accordance with accepted engineering practice.

Collar ties or ridge straps to resist wind uplift shall be connected into the upper third of the attic space top plates in accordance with Table R602.3(1).

Collar ties Each rafter shall be not less than 1 inch by 4 inches (25 mm by 102 mm) (nominal), spaced not more than 4 feet (1219 mm) on center tied across the structure with a rafter tie or a 2x4 kicker connected to the ceiling diaphragm with nails equivalent in capacity to Table R802.5.2.

R802.3.2 R802.5.2.1 Ceiling joists lapped. Ends of ceiling joists shall be lapped not less than 3 inches (76 mm) or butted over bearing partitions or beams and toenailed to the bearing member. Where ceiling joists are used to provide resistance to rafter thrust, lapped joists shall be nailed together in accordance with Table ~~R802.5.1(9)~~R802.5.2, and butted joists shall be tied together in a manner to resist such thrust. Joists that do not resist thrust shall be permitted to be nailed in accordance with Table R602.3(1).

R802.5.2.2 Rafter ties. Wood rafter ties shall be not less than 2 inches by 4 inches installed in accordance with Table R802.5.2 at each rafter. Other approved rafter tie methods shall be permitted.

R802.3.3 R802.5.2.3 Blocking. Blocking shall be a minimum of utility grade lumber.

Related changes

1. Renumber the following tables:
R802.4(1) as R802.5.1(1) - no change to table.
R802.4(2) as R802.5.1(2) - no change to table.
R802.5.1(1) as R802.4.1(1) - no change to table.
R802.5.1(2) as R802.4.1(2) - no change to table.
R802.5.1(3) as R802.4.1(3) - no change to table.
R802.5.1(4) as R802.4.1(4) - no change to table.
R802.5.1(5) as R802.4.1(5) - no change to table.
R802.5.1(6) as R802.4.1(6) - no change to table.
R802.5.1(7) as R802.4.1(7) - no change to table.
R802.5.1(8) as R802.4.1(8) - no change to table.
R802.5.1(9) as R802.5.2 - no change to table.
2. Renumber Figure R802.5.1 as R802.4.5
and delete all cross references to section numbers from the table.
and delete "Note: Where ceiling joists..."
3. Renumber the cross reference in Table R602.3(1), item 4:
Table R802.5.1(9) as R802.5.2

Reason:

WHAT: This code proposal is a rewrite with minor technical changes. It is intended to reorganize the roof and ceiling assembly by separating out the requirements of the components:

R802.3 Ridge
 R802.4 Rafters
 R802.5 Ceiling joists

WHY: The current text is rather scrambled and the major components intermingled. It is not easy to read or understand.

This is a clean version without strikethroughs and underlines for your enhanced reading:

R802.2 Design and construction. The roof and ceiling assembly shall provide a continuous tie across the structure to prevent thrust from being applied to the supporting walls. The assembly shall be designed and constructed in accordance with the provisions of this chapter and Figures R606.11(1), R606.11(2) and R606.11(3) or in accordance with AWC NDS.

R802.3 Ridge. A ridge board used to connect opposing rafters shall be not less than 1 inch (nominal) thickness and not less in depth than the cut end of the rafter. Where ceiling joist or rafter ties do not provide a continuous tie across the structure a ridge beam shall be provided and supported on each end by a wall or girder.

R802.4 Rafters. Rafters shall be in accordance with this section.

R802.4.1 Rafter size. Rafters shall be sized based on the rafter spans in Tables R802.4.1(1) through R802.4.1(8). Rafter spans shall be measured along the horizontal projection of the rafter. For other grades and species and for other loading conditions, refer to the AWC STJR.

R802.4.2 Framing details. Rafters shall be framed not more than 1-1/2-inch offset from each other to a ridge board or directly opposite from each other with a collar tie, gusset plate or ridge strap. Rafters shall be nailed to the top wall plates in accordance with Table R602.3(1) unless the roof assembly is required to comply with the uplift requirements of Section R802.11.

R802.4.3 Hips and valleys. Hip and valley rafters shall be not less than 2-inch nominal thickness and not less in depth than the cut end of the rafter. Hip and valley rafters shall be supported at the ridge by a brace to a bearing partition or be designed to carry and distribute the specific load at that point.

R802.4.4 Rafter supports. Where the roof pitch is less than 3 units vertical in 12 units horizontal (25-percent slope), structural members that support rafters, such as ridges, hips and valleys, shall be designed as beams.

R802.4.5 Purlins. Installation of purlins to reduce the span of rafters is permitted as shown in Figure R802.4.5. Purlins shall be sized not less than the required size of the rafters that they support. Purlins shall be continuous and shall be supported by 2 inch by 4 inch braces installed to bearing walls at a slope not less than 45 degrees from the horizontal. The braces shall be spaced not more than 4 feet on center and the unbraced length of braces shall not exceed 8 feet.

R802.4.6 Collar ties. Where collar ties are used to connect opposing rafters, they shall be located in the upper third of the attic space and fastened in accordance with Table R602.3(1). Collar ties shall be not less than 1 inch by 4 inch (nominal), spaced not more than 4 feet on center. Ridge straps shall be permitted to replace collar ties.

R802.5 Ceiling joists. Ceiling joists shall be continuous across the structure or securely joined where they meet over interior partitions in accordance with Table R802.5.2.

R802.5.1 Ceiling joist size. Ceiling joists shall be sized based on the joist spans in Tables R802.5.1(1) and R802.5.1(2). For other grades and species and for other loading conditions, refer to the AWC STJR.

R802.5.2 Ceiling joist and rafter connections. Where ceiling joists run parallel to rafters, they shall be connected to the rafters at the top wall plate in accordance with Table R802.5.2. Where ceiling joists are not connected to the rafters at the top wall plate, they shall be installed in the bottom third of the rafter height in accordance with Figure R802.4.5. and Table R802.5.2. Where the ceiling joists are installed above the bottom third of the rafter height, the ridge shall be designed as a beam.

Where ceiling joists do not run parallel to rafters, the ceiling joists shall be connected to the top plates in accordance with Table R602.3(1). Each rafter shall be tied across the structure with a rafter tie or a 2x4 kicker connected to the ceiling diaphragm with nails equivalent in capacity to Table R802.5.2.

R802.5.2.1 Ceiling joists lapped. Ends of ceiling joists shall be lapped not less than 3 inches or butted over bearing partitions or beams and toenailed to the bearing member. Where ceiling joists are used to provide resistance to rafter thrust, lapped joists shall be nailed together in accordance with Table R802.5.2 and butted joists shall be tied together in a manner to resist such thrust. Ceiling joists that do not resist thrust shall be permitted to be nailed in accordance with Table R602.3(1).

R802.5.2.2 Rafter ties. Wood rafter ties shall be not less than 2 inches by 4 inches installed in accordance with Table R802.5.2 at each rafter. Other approved rafter tie methods shall be permitted.

R802.5.2.3 Blocking. Blocking shall be a minimum of utility grade lumber.

This is a table of how the reorganized material was accumulated.

NEW SECTION	TITLE	CHANGE	ORIGINAL SOURCE
R802.2	Design and Construction	editing	R802.2
R802.3	Ridge	pulled out and edited	R802.3
R802.4	Rafters	new charging language	
R802.4.1	Rafter size	editing	R802.5
R802.4.2	Framing details	editing	R802.3.1
R802.4.3	Hips and valleys	pulled out and edited	R802.3
R802.4.4	Rafter supports	pulled out and edited	R802.3
R802.4.5	Purlins	edited cross reference number	R802.5.1
R802.4.6	Collar ties	pulled out and edited	R802.3.1
R802.5	Ceiling joists	new charging language	
R802.5.1	Ceiling joist size	editing	R802.4
R802.5.2	Ceiling joist and rafter connections	editing	R802.3.1

NEW SECTION	TITLE	CHANGE	ORIGINAL SOURCE
R802.5.2.1	Ceiling joists lapped	edited cross reference numbers	R802.3.2
R802.5.2.2	Rafter ties	pulled out and edited	R802.3.1
R802.5.2.3	Blocking	no change	R802.3.3
FIGURE R802.4.5	Braced rafter construction	deleted all cross references to section numbers and table numbers	R802.5.1

Cost Impact: Will not increase the cost of construction

This rewrite is essentially a non-technical code change intened to reorganize the section by components of the roof-ceiling assembly. It should not impact the cost of roof construction.

Report of Committee Action Hearings

Committee Action:

Approved as Modified

Modify as follows:

R802.2 Design and construction. The roof and ceiling assembly shall provide a continuous tie-ties across the structure to prevent roof thrust from being applied to the supporting walls. The assembly shall be designed and constructed in accordance with the provisions of this chapter and Figures R606.11(1), R606.11(2) and R606.11(3) or in accordance with AWC NDS.

R802.4.2 Framing details. Rafters shall be framed not more than 1¹/₂-inch (38 mm) offset from each other to a ridge board or directly opposite from each other with a collar tie, gusset plate or ridge strap in accordance with Table R602.3(1). Rafters shall be nailed to the top wall plates in accordance with Table R602.3(1) unless the roof assembly is required to comply with the uplift requirements of Section R802.11.

R802.3 Ridge. A ridge board used to connect opposing rafters shall be not less than 1 inch (nominal) thickness and not less in depth than the cut end of the rafter. Where ceiling joist or rafter ties do not provide a continuous tie-ties across the structure, a ridge beam shall be provided and supported on each end by a wall or girder.

R802.4.6 Collar ties. Where collar ties are used to connect opposing rafters, they shall be located in the upper third of the attic space and fastened in accordance with Table R602.3(1). Collar ties shall be not less than 1 inch by 4 inch (nominal), spaced not more than 4 feet on center. Ridge straps in accordance with Table R602.3(1) shall be permitted to replace collar ties.

R802.4.4 Rafter supports. Where the roof pitch is less than 3 units vertical in 12 units horizontal (25-percent slope), structural members that support rafters, such as ridges, hips and valleys, shall be designed as beams, and bearing shall be provided for rafters in accordance with R802.6.

Committee Reason: The committee approved this proposal based on the proponents published reason statement. This change allows the use of the rafter tables for roof slope less than 3:12. The modifications clarifies the continuous ties, provides a pointer for the ridge strap back to the fastener table and adds the requirement for bearing for beams of roofs with slope less than 3:12.

Assembly Action

None

Final Action Results

RB310-16

AM

[←BACK](#)

Code Change No: **RB314-16**

Original Proposal

Section: R802.1.5.4

Proponent: Joseph Holland (jholland@frtw.com)

Revise as follows:

R802.1.5.4 Labeling. ~~Fire-retardant-treated~~ In addition to the labels required by Section 802.1.1 for sawn lumber and Section 803.2.1 for wood structural panels each piece of fire-retardant-treated lumber and wood structural panels shall be *labeled*. The *label* shall contain:

1. The identification *mark* of an *approved agency* in accordance with Section 1703.5 of the *International Building Code*.
2. Identification of the treating manufacturer.
3. The name of the fire-retardant treatment.
4. The species of wood treated.
5. Flame spread index and smoke-developed index.
6. Method of drying after treatment.
7. Conformance to applicable standards in accordance with Sections R802.1.5.5 through R802.1.5.10.
8. For FRTW exposed to weather, or a damp or wet location, the words "No increase in the listed classification when subjected to the Standard Rain Test" (ASTM D 2898).

Reason: There are products coming into the marketplace that have obscured the labels required by Section 802.1.1 and 803.2.1. This change clarifies that FRTW must have two labels: one for the grading of the wood, the other for the treatment. There are also manufacturers making the claim for a lift of lumber or wood structural panel. The change clarifies each piece must be labeled with both marks.

Cost Impact: Will not increase the cost of construction
Manufacturer's treating in accordance with the code requirement for pressure treatment or other means during manufacturer already mark each piece. The proposal clarifies, for others, what is already being done.

Report of Committee Action Hearings

Committee Action:

Approved as Submitted

Committee Reason: The committee approved this proposal based on the proponents published reason statement.

Assembly Action:

None

Final Action Results

RB314-16

AS

Code Change No: **RB315-16**

Original Proposal

Section: R802.1.8 (New)

Proponent: Edward Keith, representing APA- The Engineered Wood Association (ed.keith@apawood.org)

Add new text as follows:

R802.1.8 Prefabricated wood I-joists. Structural capacities and design provisions for prefabricated wood I-joists shall be established and monitored in accordance with ASTM D5055.

Reason: This proposal adds prefabricated wood I-joists to the list of wood and wood-based products listed in the IRC for roof framing. Prefabricated wood I-joists have been used in roof framing in commercial and residential projects for over 25 years. Prefabricated wood I-joists are already recognized in Section R802.7.2 as part of a description of engineered wood products. As is customary in the IRC, recognition of the product and its relevant manufacturing standard is provided at the beginning of relevant chapters. This links the I-joist product to the relevant standard.

Note that the language proposed is exactly the same as used in the Chapter 5 of the IRC in Section R502.1.2.

Cost Impact: Will not increase the cost of construction

This proposal will not increase the cost of construction as the change is editorial in nature.

Report of Committee Action Hearings

Committee Action:

Approved as Submitted

Committee Reason: This proposal add prefabricated wood I-joist and the reference standard to the roof framing provisions.

Assembly Action:

None

Final Action Results

RB315-16

AS

Code Change No: RB319-16

Original Proposal

Section: R802.5.1

Proponent: Paul Coats, PE CBO, representing American Wood Council (pcoats@awc.org)

Revise as follows:

TABLE R802.5.1 (9)
RAFTER/CEILING JOIST HEEL JOINT CONNECTIONS^{a, b, c, d, e, f-h}

RAFTER SLOPE	RAFTER SPACING (inches)	GROUND SNOW LOAD (psf)															
		20^g				30				50				70			
		Roof span (feet)															
		12	20	28	36	12	20	28	36	12	20	28	36	12	20	28	36

		Required number of 16d common nails ^{a, b} per heel joint splices ^{c, d, e, f}															
3:12	12	4	6	8	10	4	6	8	11	5	8	12	15	6	11	15	20
	16	5	8	10	13	5	8	11	14	6	11	15	20	8	14	20	26
	24	7	11	15	19	7	11	16	21	9	16	23	30	12	21	30	39
4:12	12	3	5	6	8	3	5	6	8	4	6	9	11	5	8	12	15
	16	4	6	8	10	4	6	8	11	5	8	12	15	6	11	15	20
	24	5	8	12	15	5	9	12	16	7	12	17	22	9	16	23	29
5:12	12	3	4	5	6	3	4	5	7	3	5	7	9	4	7	9	12

	16	3	5	6	8	3	5	7	9	4	7	9	12	5	9	12	16
	24	4	7	9	12	4	7	10	13	6	10	14	18	7	13	18	23
7:12	12	3	4	4	5	3	3	4	5	3	4	5	7	3	5	7	9
	16	3	4	5	6	3	4	5	6	3	5	7	9	4	6	9	11
	24	3	5	7	9	3	5	7	9	4	7	10	13	5	9	13	17
9:12	12	3	3	4	4	3	3	3	4	3	3	4	5	3	4	5	7
	16	3	4	4	5	3	3	4	5	3	4	5	7	3	5	7	9

	24	3	4	6	7	3	4	6	7	3	6	8	10	4	7	10	13
12:12	12	3	3	3	3	3	3	3	3	3	3	3	4	3	3	4	5
	16	3	3	4	4	3	3	3	4	3	3	4	5	3	4	5	7
	24	3	4	4	5	3	3	4	6	3	4	6	8	3	6	8	10

For SI: 1 inch = 25.4 mm, 1 foot = 304.8 mm, 1 pound per square foot = 0.0479 kPa.

- a. 40d box nails shall be permitted to be substituted for 16d common nails.
- b. Nailing requirements shall be permitted to be reduced 25 percent if nails are clinched.
- c. Heel joint connections are not required where the ridge is supported by a load-bearing wall, header or ridge beam.
- d. Where intermediate support of the rafter is provided by vertical struts or purlins to a load-bearing wall, the tabulated heel joint connection requirements shall be permitted to be reduced proportionally to the reduction in span.
- e. Equivalent nailing patterns are required for ceiling joist to ceiling joist lap splices.
- f. Where rafter ties are substituted for ceiling joists, the heel joint connection requirement shall be taken as the tabulated heel joint connection requirement for two-thirds of the actual rafter slope.
- g. Applies to roof live load of 20 psf or less.
- h. Tabulated heel joint connection requirements assume that ceiling joists or rafter ties are located at the bottom of the attic space. Where ceiling joists or rafter ties are located higher in the attic, heel joint connection requirements shall be increased by the following factors:

H_C/H_R	Heel Joint Connection Adjustment Factor
1/3	1.5
1/4	1.33
1/5	1.25
1/6	1.2
1/10 or less	1.11

where:

H_C = Height of ceiling joists or rafter ties measured vertically above the top of the rafter support walls.
 H_R = Height of roof ridge measured vertically above the top of the rafter support walls.

Reason: Footnote "f" is redundant to footnote "h" in purpose. Footnote "f" should have been removed at the time footnote "h" was added to better account for the effect of rafter ties located above the bottom of the attic space. The approach in footnote "h" allows application for use on lower slope rafter systems, less penalty for smaller raised distances, and a more simple method to determine heel joint connection requirements. There is no change to footnote h.

Cost Impact: Will not increase the cost of construction

This is an editorial change that removes an unneeded provision which is captured by another footnote, and therefore represents no increase in cost of construction.

Report of Committee Action Hearings
--

Committee Action:

Approved as Submitted

Committee Reason: The committee approved this proposal based on the proponents published reason statement. Footnote f is redundant.

Assembly Action:

None

Final Action Results

RB319-16

AS

[←BACK](#)

Code Change No: **RB321-16**

Original Proposal

Section: R804.1.1, R804.3.1.1, R804.3.2.1, R804.3.6, R804.3.7.1

Proponent: Jon-Paul Cardin, American Iron and Steel Institute, representing American Iron and Steel Institute (JCardin@steel.org)

Revise as follows:

R804.1.1 Applicability limits. The provisions of this section shall control the construction of cold-formed steel roof framing for buildings not greater than 60 feet (18 288 mm) perpendicular to the joist, rafter or truss span, not greater than 40 feet (12 192 mm) in width parallel to the joist span or truss, less than or equal to three stories above *grade* plane and with roof slopes not less than 3:12 (25-percent slope) or greater than 12:12 (100-percent slope). Cold-formed steel roof framing constructed in accordance with the provisions of this section shall be limited to sites where the ultimate design wind speed is less than ~~439~~ 140 miles per hour (~~6263~~ m/s), Exposure Category B or C, and the ground snow load is less than or equal to 70 pounds per square foot (3350 Pa).

R804.3.1.1 Minimum ceiling joist size. Ceiling joist size and thickness shall be determined in accordance with the limits set forth in Tables R804.3.1.1(1) and R804.3.1.1(2). When determining the size of ceiling joists, the lateral support of the top flange shall be classified as unbraced, braced at midspan or braced at third points in accordance with Section ~~R804.3.1.4~~ R804.3.1.3. Where sheathing material is attached to the top flange of ceiling joists or where the bracing is spaced closer than third point of the joists, the "third point" values from Tables R804.3.1.1(1) and R804.3.1.1(2) shall be used.

Ceiling joists shall have a bearing support length of not less than 1 1/2 inches (38 mm) and shall be connected to roof rafters (heel joint) with No. 10 screws in accordance with Figure R804.3.1.1 and Table 804.3.1.1(3).

Where continuous joists are framed across interior bearing supports, the interior bearing supports shall be located within 24 inches (610) mm of midspan of the ceiling joist, and the individual spans shall not exceed the applicable spans in Tables R804.3.1.1(1) and R804.3.1.1(2).

Where the *attic* is to be used as an occupied space, the ceiling joists shall be designed in accordance with Section R505.

TABLE R804.3.1.1 (1)
CEILING JOIST SPANS 10 PSF LIVE LOAD (NO ATTIC STORAGE)^{a, b, c}

MEMBER DESIGNATION	ALLOWABLE SPAN (feet - inches)					
	Lateral Support of Top (Compression) Flange					
	Unbraced	Midspan Bracing		Third-point Bracing		
	Ceiling Joist Spacing (inches)					
	16	24	16	24	16	24
350S162-33	<u>9'-5" 9'-6"</u>	8'-6"	<u>12'-2" 11'-10"</u>	<u>10'-4" 9'-10"</u>	<u>12'-2" 11'-10"</u>	<u>10'-7" 10'-4"</u>
350S162-43	<u>10'-3" 10'-4"</u>	<u>9'-12" 9'-3"</u>	<u>13'-2" 12'-10"</u>	<u>11'-6" 11'-3"</u>	<u>13'-2" 12'-10"</u>	<u>11'-6" 11'-3"</u>
350S162-54	11'-1"	9'-11"	13'-9"	12'-0"	13'-9"	12'-0"
350S162-68	<u>12'-1" 12'-2"</u>	<u>10'-9" 10'-10"</u>	<u>14'-8" 14'-9"</u>	12'-10"	<u>14'-8" 14'-9"</u>	12'-10"
550S162-33	<u>10'-7" 10'-11"</u>	<u>9'-6" 9'-10"</u>	<u>14'-10" 15'-7"</u>	<u>12'-10" 12'-0"</u>	<u>15'-11" 16'-10"</u>	<u>13'-4" 12'-0"</u>
550S162-43	11'-8"	10'-6"	<u>16'-4" 16'-10"</u>	<u>14'-3" 14'-10"</u>	<u>17'-10" 18'-4"</u>	<u>15'-3" 16'-0"</u>
550S162-54	<u>12'-6" 12'-7"</u>	<u>11'-2" 11'-3"</u>	<u>17'-7" 18'-0"</u>	<u>15'-7" 16'-2"</u>	<u>19'-5" 19'-4"</u>	<u>16'-10" 17'-2"</u>
550S162-68	<u>13'-6" 13'-7"</u>	12'-1"	<u>19'-2" 19'-3"</u>	<u>17'-0" 17'-3"</u>	<u>21'-0" 20'-6"</u>	<u>18'-4" 18'-5"</u>
800S162-33	—	—	—	—	—	—
800S162-43	<u>13'-0" 13'-1"</u>	11'-9"	<u>18'-10" 18'-9"</u>	<u>17'-0" 16'-9"</u>	<u>21'-6" 21'-2"</u>	<u>19'-0" 18'-7"</u>
800S162-54	<u>13'-10" 13'-11"</u>	<u>12'-5" 12'-6"</u>	<u>20'-0" 20'-1"</u>	<u>18'-0" 18'-1"</u>	<u>22'-9" 21'-5"</u>	<u>20'-4" 20'-5"</u>
800S162-68	14'-11"	13'-4"	<u>21'-3" 21'-4"</u>	<u>19'-1" 19'-2"</u>	<u>24'-1" 22'-9"</u>	<u>21'-8" 21'-9"</u>
1000S162-43	—	—	—	—	—	—
1000S162-54	<u>14'-9" 14'-10"</u>	<u>13'-3" 13'-4"</u>	21'-4"	<u>19'-3" 19'-2"</u>	<u>24'-4" 22'-8"</u>	<u>22'-0" 21'-8"</u>
1000S162-68	15'-10"	<u>14'-2" 14'-3"</u>	<u>22'-8" 22'-9"</u>	20'-5"	<u>25'-9" 24'-3"</u>	<u>23'-2" 23'-3"</u>
1200S162-43	—	—	—	—	—	—
1200S162-54	—	—	—	—	—	—
1200S162-68	16'-8"	14'-11"	23'-11"	<u>21'-6" 21'-7"</u>	<u>27'-2" 25'-5"</u>	<u>24'-6" 24'-5"</u>

For SI: 1 inch = 25.4 mm, 1 foot = 304.8 mm, 1 mil = 0.0254 mm, 1 pound per square foot = 0.0479 kPa.

a. Deflection criterion: $L/240$ for total loads.

- b. Ceiling dead load = 5 psf.
- c. Minimum Grade 33 ksi steel shall be used for 33 mil and 43 mil thicknesses. Minimum Grade 50 ksi steel shall be used for 54 and 68 mil thicknesses.
- d. Listed allowable spans are not applicable for 350S162-33, 550S162-33, 550S162-43, and 800S162-43 continuous joist members.

TABLE R804.3.1.1 (2)
CEILING JOIST SPANS 20 PSF LIVE LOAD (LIMITED ATTIC STORAGE)^{a, b, c}

MEMBER DESIGNATION	ALLOWABLE SPAN (feet - inches)					
	Lateral Support of Top (Compression) Flange					
	Unbraced	Midspan Bracing		Third-point Bracing		
	Ceiling Joist Spacing (inches)					
	16	24	16	24	16	24
350S162-33	8'-2" <u>8'-0"</u>	6'-10" <u>6'-5"</u>	9'-9" <u>9'-2"</u>	6'-10" <u>7'-5"</u>	9'-11"	6'-10" <u>7'-5"</u>
350S162-43	8'-10" <u>8'-11"</u>	7'-10" <u>7'-8"</u>	11'-0" <u>10'-9"</u>	9'-5" <u>8'-9"</u>	11'-0" <u>10'-10"</u>	9'-7" <u>9'-6"</u>
350S162-54	9'-6" <u>9'-7"</u>	8'-6" <u>8'-7"</u>	11'-9" <u>11'-7"</u>	10'-3" <u>10'-2"</u>	11'-9" <u>11'-7"</u>	10'-3" <u>10'-2"</u>
350S162-68	10'-4"	9'-2" <u>9'-3"</u>	12'-7" <u>12'-5"</u>	11'-0" <u>10'-10"</u>	12'-7" <u>12'-5"</u>	11'-0" <u>10'-10"</u>
550S162-33	9'-2" <u>9'-5"</u>	8'-3" <u>6'-11"</u>	12'-2" <u>10'-5"</u>	8'-5" <u>6'-11"</u>	12'-6" <u>10'-5"</u>	8'-5" <u>6'-11"</u>
550S162-43	10'-1" <u>10'-2"</u>	9'-1" <u>9'-2"</u>	13'-7" <u>14'-2"</u>	11'-8"	14'-5" <u>15'-2"</u>	12'-2" <u>11'-8"</u>
550S162-54	10'-9" <u>10'-10"</u>	9'-8" <u>9'-9"</u>	14'-10" <u>15'-7"</u>	12'-10" <u>14'-0"</u>	15'-11" <u>16'-7"</u>	13'-6" <u>14'-5"</u>
550S162-68	11'-7" <u>11'-8"</u>	10'-4" <u>10'-5"</u>	16'-4" <u>16'-7"</u>	14'-0" <u>14'-10"</u>	17'-5" <u>17'-9"</u>	14'-11" <u>15'-6"</u>
800S162-33	—	—	—	—	—	—
800S162-43	11'-4"	10'-1" <u>10'-2"</u>	16'-5" <u>16'-1"</u>	13'-6" <u>11'-0"</u>	18'-1" <u>16'-6"</u>	13'-6" <u>11'-0"</u>
800S162-54	20'-0" <u>12'-0"</u>	10'-9" <u>10'-10"</u>	17'-4"	15'-6" <u>15'-7"</u>	19'-6" <u>18'-7"</u>	27'-0" <u>17'-7"</u>
800S162-68	12'-10"	11'-6" <u>11'-6"</u>	18'-5" <u>18'-6"</u>	16'-6" <u>16'-7"</u>	20'-10" <u>19'-11"</u>	18'-3" <u>18'-11"</u>
1000S162-43	—	—	—	—	—	—
1000S162-54	12'-10"	11'-6" <u>11'-7"</u>	18'-7" <u>18'-5"</u>	16'-9" <u>16'-6"</u>	21'-2" <u>19'-8"</u>	15'-5" <u>18'-8"</u>

1000S162-68	13'-8"	12'-3"	19'-8"	47'-8" 17'-9"	22'-4" 21'-1"	20'-1"
1200S162-43	—	—	—	—	—	—
1200S162-54	—	—	—	—	—	—
1200S162-68	44'-4" 14'-5"	12'-11"	20'-9"	18'-8" 18'-7"	23'-7" 22'-0"	21'-3" 21'-0"

For SI: 1 inch = 25.4 mm, 1 foot = 304.8 mm, 1 mil = 0.0254 mm, 1 pound per square foot = 0.0479 kPa.

a. Deflection criterion: L/240 for total loads.

b. Ceiling dead load = 5 psf.

c. Minimum Grade 33 ksi steel shall be used for 33 mil and 43 mil thicknesses. Minimum Grade 50 ksi steel shall be used for 54 and 68 mil thicknesses.

d. Listed allowable spans are not applicable for 350S162-33, 350S162-43, 550S162-33, 550S162-43, and 800S162-43 continuous joist members.

TABLE R804.3.2.1 (1)
ROOF RAFTER SPANS^{a, b, c, d}

MEMBER DESIGNATION	ALLOWABLE SPAN MEASURED HORIZONTALLY (feet - inches)							
	Ground snow load (psf)							
	20		30		50		70	
	Rafter spacing (inches)							
	16		24		16		24	
550S162-33	44'-0" 13'-11"	11'-6" 11'- 4"	11'- 11" 11'-9"	9'-7"	9'-6" 9'-5"	7'-9" 7'-8"	8'-2" 8'-1"	6'-8" 6'-7"
550S162-43	46'-8" 15'-9"	13'- 11" 13'-8"	14'-5" 14'- 3"	11'-9" 11'- 8"	11'-6" 11'- 4"	9'-5" 9'-3"	9'-10" 9'-9"	8'-0" 7'- 11"
550S162-54	47'-11" 16'-11"	15'-7" 14'- 10"	15'-7" 15'- 3"	13'-8" 13'- 4"	13'-2" 13'- 3"	11'-6" 11'- 7"	11'-9" 12'- 0"	10'-3" 10'- 6"
550S162-68	19'-2" 18'-2"	16'-9" 15'- 10"	16'-9" 16'- 5"	14'-7" 14'- 4"	14'-1" 14'- 3"	12'-4" 12'- 5"	12'-7" 12'- 11"	11'-0" 11'- 3"
800S162-33	46'-5" 16'-4"	13'-5" 13'- 4"	13'-11"	11'-4"	11'-1"	8'-2" 9'-0"	9'-0" 9'-6"	6'-0" 6'-7"
800S162-43	49'-9" 19'-7"	46'-4" 16'-	16'-8"	13'-7"	13'-4"	10'-10"	11'-5"	9'-4"

		<u>0"</u>							
800S162-54	<u>24'-2"22'-9"</u>	<u>21'-2"19'-11"</u>	<u>21'-1"20'-7"</u>	<u>18'-5"17'-11"</u>	17'-10"	<u>14'-8"14'-9"</u>	<u>15'-5"15'-6"</u>	12'-7"	
800S162-68	<u>25'-11"24'-7"</u>	<u>22'-8"21'-6"</u>	<u>22'-8"22'-2"</u>	<u>19'-9"19'-5"</u>	<u>19'-1"19'-3"</u>	<u>16'-8"16'-10"</u>	<u>17'-1"17'-5"</u>	<u>14'-9"14'-8"</u>	
1000S162-43	<u>22'-3"22'-2"</u>	<u>18'-2"18'-1"</u>	<u>18'-9"18'-10"</u>	<u>15'-8"15'-4"</u>	<u>15'-0"15'-1"</u>	<u>12'-3"12'-4"</u>	<u>12'-40"12'-11"</u>	<u>10'-6"10'-7"</u>	
1000S162-54	<u>29'-0"27'-1"</u>	<u>24'-6"23'-8"</u>	<u>25'-4"24'-6"</u>	20'-9"	<u>20'-3"20'-5"</u>	<u>16'-7"16'-8"</u>	<u>17'-5"17'-6"</u>	<u>14'-2"14'-3"</u>	
1000S162-68	<u>31'-2"29'-5"</u>	<u>27'-3"25'-8"</u>	<u>27'-3"26'-6"</u>	<u>23'-9"23'-2"</u>	<u>20'-0"23'-0"</u>	19'-6"	20'-6"	<u>16'-8"16'-9"</u>	
1200S162-54	<u>33'-2"31'-3"</u>	<u>27'-1"27'-0"</u>	<u>28'-1"28'-1"</u>	22'-11"	<u>22'-5"22'-6"</u>	18'-4"	<u>19'-3"19'-4"</u>	<u>15'-8"15'-9"</u>	
1200S162-68	<u>36'-4"34'-0"</u>	<u>31'-9"29'-8"</u>	<u>31'-9"30'-8"</u>	<u>27'-0"26'-9"</u>	<u>26'-5"26'-6"</u>	<u>21'-6"21'-7"</u>	<u>22'-6"22'-8"</u>	18'-6"	

For SI: 1 inch = 25.4 mm, 1 foot = 304.8 mm, 1 pound per square foot = 0.0479 kPa.

- a. Table provides maximum horizontal rafter spans in feet and inches for slopes between 3:12 and 12:12.
- b. Deflection criteria: L/240 for live loads and L/180 for total loads.
- c. Roof dead load = 12 psf.
- d. Grade 33 ksi steel is permitted to be used for 33 mil and 43 mil thicknesses. Grade 50 ksi steel shall be used for 54 and 68 mil thicknesses.

TABLE R804.3.2.1 (2)
ULTIMATE DESIGN WIND SPEED TO EQUIVALENT SNOW LOAD CONVERSION

ULTIMATE WIND SPEED AND EXPOSURE		EQUIVALENT GROUND SNOW LOAD (psf)									
		Roof slope									
Exposure	Wind Speed (mph)	3:12	4:12	5:12	6:12	7:12	8:12	9:12	10:12	11:12	12:12
B	<u>115</u>	<u>20</u>	<u>20</u>	<u>20</u>	<u>20</u>	<u>30</u>	<u>20</u>	<u>30</u>	<u>30</u>	<u>30</u>	<u>50</u>
	<u>120</u>	<u>20</u>	<u>20</u>	<u>20</u>	<u>20</u>	<u>30</u>	<u>30</u>	<u>30</u>	<u>30</u>	<u>30</u>	<u>50</u>
	<u>130</u>	<u>20</u>	<u>20</u>	<u>20</u>	<u>20</u>	<u>30</u>	<u>30</u>	<u>30</u>	<u>50</u>	<u>50</u>	<u>50</u>

	<u><140</u>	<u>20</u>	<u>20</u>	<u>20</u>	<u>20</u>	<u>30</u>	<u>50</u>	<u>50</u>	<u>50</u>	<u>50</u>	<u>50</u>
C	<u>115</u>	<u>20</u>	<u>20</u>	<u>20</u>	<u>20</u>	<u>30</u>	<u>30</u>	<u>30</u>	<u>50</u>	<u>50</u>	<u>50</u>
	<u>120</u>	<u>20</u>	<u>20</u>	<u>20</u>	<u>20</u>	<u>30</u>	<u>30</u>	<u>50</u>	<u>50</u>	<u>50</u>	<u>50</u>
	<u>130</u>	<u>20</u>	<u>20</u>	<u>20</u>	<u>30</u>	<u>30</u>	<u>50</u>	<u>50</u>	<u>50</u>	<u>50</u>	<u>70</u>
	<u><140</u>	<u>30</u>	<u>30</u>	<u>30</u>	<u>50</u>	<u>50</u>	<u>50</u>	<u>70</u>	<u>70</u>	<u>70</u>	<u>=</u>

For SI: 1 mile per hour = 0.447 m/s, 1 pound per square foot = 0.0479 kPa.

R804.3.6 Roof trusses. Cold-formed steel trusses shall be designed and installed in accordance with AISI S400, Section D4 S240. In the absence of specific bracing requirements, trusses shall be braced in accordance with accepted industry practices, such as the SBCA *Cold-Formed Steel Building Component Safety Information (CFSBCSI) Guide to Good Practice for Handling, Installing & Bracing of Cold-Formed Steel Trusses*. Trusses shall be connected to the top track of the load-bearing wall in accordance with Table R804.3, either with two No. 10 screws applied through the flange of the truss or by using a 54-mil (1.37 mm) clip angle with two No. 10 screws in each leg.

TABLE R804.3.7.1
REQUIRED LENGTHS FOR CEILING DIAPHRAGMS AT GABLE ENDWALLS GYPSUM BOARD SHEATHED,
CEILING HEIGHT = 8 FEET^{a, b, c, d, e, f, g}

EXPOSURE CATEGORY		ULTIMATE DESIGN WIND SPEED (mph)					
B		<u>126</u> <u>115</u>	<u><139</u> <u>120</u>	<u>—</u> <u>130</u>	<u>—</u> <u><140</u>	<u>=</u>	<u>=</u>
C		<u>110</u> <u>=</u>	<u>—</u>	<u>126</u> <u>115</u>	<u><139</u> <u>120</u>	<u>130</u>	<u><140</u>
Roof pitch	Building endwall width (feet)	Minimum diaphragm length (feet)					
3:12 to 6:12	24 - 28	<u>20</u> <u>16</u>	<u>22</u> <u>18</u>	<u>28</u> <u>24</u>	<u>32</u> <u>26</u>	<u>30</u>	<u>34</u>
	> 28 - 32	<u>22</u> <u>20</u>	<u>28</u> <u>20</u>	<u>32</u> <u>26</u>	<u>38</u> <u>32</u>	<u>34</u>	<u>40</u>
	> 32 - 36	<u>26</u> <u>24</u>	<u>32</u> <u>26</u>	<u>38</u> <u>30</u>	<u>44</u> <u>36</u>	<u>42</u>	<u>46</u>
	> 36 - 40	<u>30</u> <u>26</u>	<u>36</u> <u>28</u>	<u>44</u> <u>36</u>	<u>50</u> <u>40</u>	<u>48</u>	<u>52</u>
6:12 to 9:12	> 24 - 28	<u>22</u> <u>20</u>	<u>26</u> <u>20</u>	<u>32</u> <u>26</u>	<u>36</u> <u>30</u>	<u>34</u>	<u>38</u>
	> 28 - 32	<u>26</u> <u>24</u>	<u>32</u> <u>26</u>	<u>38</u> <u>30</u>	<u>44</u> <u>36</u>	<u>42</u>	<u>46</u>
	> 32 - 36	<u>32</u> <u>26</u>	<u>38</u> <u>30</u>	<u>44</u> <u>38</u>	<u>52</u> <u>42</u>	<u>48</u>	<u>54</u>

	> 36 - 40	3630	4434	5240	6050	56	62
9:12 to 12:12	> 24 - 28	2622	3024	3630	4234	38	44
	> 28 - 32	3026	3628	4236	5040	46	52
	> 32 - 36	3630	4232	5040	6048	54	62
	> 36 - 40	4236	5038	6048	7056	64	72

For SI: 1 inch = 25.4 mm, 1 pound per square foot = 0.0479 kPa, 1 mile per hour = 0.447 m/s, 1 foot = 304.8 mm, 1 mil = 0.0254 mm.

- Ceiling diaphragm is composed of 1/2-inch gypsum board (min. thickness) secured with screws spaced at 6 inches o.c. at panel edges and 12 inches o.c. in field. Use No. 8 screws (min.) where framing members have a designation thickness of 54 mils or less and No. 10 screws (min.) where framing members have a designation thickness greater than 54 mils.
- Maximum aspect ratio (length/width) of diaphragms is 2:1.
- Building width is in the direction of horizontal framing members supported by the wall studs.
- Required diaphragm lengths are to be provided at each end of the structure.
- Multiplying required diaphragm lengths by 0.35 is permitted if all panel edges are blocked.
- Multiplying required diaphragm lengths by 0.9 is permitted if all panel edges are secured with screws spaced at 4 inches o.c.
- To determine the minimum diaphragm length for buildings with ceiling heights of 9 feet or 10 feet values in the table above shall be multiplied by 1.15.

Reference standards type: This reference standard is new to the ICC Code Books
Add new standard(s) as follows:

AISI S240-15, North American Standard for Cold-Formed Steel Structural Framing (2015)

Standards are available for free download at www.aisistandards.org

Reason: The proposal is one in a series intended to update the content of the Cold-Formed Steel (CFS) light-framed construction provisions of the IRC. The proposed revisions align the IRC with the provisions of *AISI S230-15, Standard for Cold-Formed Steel Framing - Prescriptive Method for One- and Two-Family Dwellings*. The wind loads are adjusted to conform to the provisions of the ASCE 7-10 Directional Procedure, and the wind speed increments are modified to correlate with increments as shown in the wind speed maps (Figures R301.2(4)A and B). Editorial corrections have been made to the text where applicable. Further explanation for each section follows:

Section R804.1.1 Applicability Limits - This proposal adjusts the upper limit of the ultimate design wind speed from less than 139 miles per hour (mph) to less than 140 mph. The previous upper limit was based on a conversion of the wind speed from a nominal speed to an ultimate speed. For which, the conversion of the 110 mph nominal wind speed resulted in a rounded value of 139 mph ultimate wind speed upper limit (ie. less than 139 mph). This is detailed in the last cycle code change proposal RB258-13. Since the wind speeds now listed in this section are actual ultimate wind speeds, as derived from the ultimate wind speed maps, this section is now applicable for ultimate wind speeds up to 140 mph.

Tables R804.3.1.1(1), R804.3.1.1(2), and R804.3.2.1 - The listed allowable spans are updated to correlate with AISI S230.

Table R804.3.2.1(2) Wind speed to snow load conversion - This table replaces the previous conversion table to correlate with AISI S230.

Section R804.3.6 Roof Trusses - Previously this section referenced AISI S100, Section D4 for truss design. Section D4 of AISI S100 directed the user to *AISI S214 - North American Standard for Cold-Formed Steel Framing - Truss Design*. However, the new standard **AISI S240, North American Standard for Cold-Formed Steel Structural Framing**, addresses requirements for construction with cold-formed steel structural framing that are common to prescriptive and engineered light frame construction. This comprehensive standard was formed by merging the following AISI standards:

- AISI S200, *North American Standard for Cold-Formed Steel Framing-General Provisions*
- AISI S210, *North American Standard for Cold-Formed Steel Framing-Floor and Roof System Design*
- AISI S211, *North American Standard for Cold-Formed Steel Framing-Wall Stud Design*
- AISI S212, *North American Standard for Cold-Formed Steel Framing-Header Design*
- AISI S213, *North American Standard for Cold-Formed Steel Framing-Lateral Design*
- AISI S214, North American Standard for Cold-Formed Steel Framing-Truss Design

Consequently, AISI S240 supersedes all previous editions of the above mentioned individual AISI standards and is the correct reference for this application.

Table R804.3.7.1 Required lengths for ceiling diaphragms - The required diaphragm lengths are modified to accommodate the corresponding wind load adjustments as previously stated.

The AISI Standards are available for free download at www.aisistandards.org

Cost Impact: Will increase the cost of construction

The proposed changes to this section will not increase the cost of construction in general. While the overwhelming majority of the prescribed members have not changed or are reduced in size, there may be conditions for which the minimum member size will increase.

Analysis: A review of the standard(s) proposed for inclusion in the code, AISI 240 - 15, with regard to the ICC criteria for referenced standards (Section 3.6 of CP#28) will be posted on the ICC website on or before April 1, 2016.

Report of Committee Action Hearings
--

Committee Action:**Approved as Submitted**

Committee Reason: This change aligns the cold-formed steel wall framing provisions with the new referenced cold-formed steel structural framing standard.

Also, the applicable design wind speed is changed to less than 140 mph ultimate. The framing tables are revised to reflect the wind load increase and to align with ASCE 7-10. Directional Method.

Assembly Action:**None**

Final Action Results

RB321-16**AS**

[←BACK](#)

Code Change No: **RB323-16**

Original Proposal

Section: R806.1, R806.3

Proponent: Mike Fischer, Kellen, representing Asphalt Roofing Manufacturers Association (mfischer@kellencompany.com)

Revise as follows:

R806.1 Ventilation required. Enclosed attics and enclosed rafter spaces formed where ceilings are applied directly to the underside of roof rafters shall have cross ventilation for each separate space by ventilating openings protected against the entrance of rain or snow. Ventilation openings shall have a least dimension of $\frac{1}{16}$ inch (1.6 mm) minimum and $\frac{1}{4}$ inch (6.4 mm) maximum. Ventilation openings having a least dimension larger than $\frac{1}{4}$ inch (6.4 mm) shall be provided with corrosion-resistant wire cloth screening, hardware cloth, perforated vinyl or similar material with openings having a least dimension of $\frac{1}{16}$ inch (1.6 mm) minimum and $\frac{1}{4}$ inch (6.4 mm) maximum. Openings in roof framing members shall conform to the requirements of Section R802.7. Required ventilation openings shall open directly to the outside air and shall be protected to prevent the entry of birds, rodents, snakes and other similar creatures.

R806.3 Vent and insulation clearance. Where eave or cornice vents are installed, blocking, bridging and insulation shall not block the free flow of air. Not less than a 1-inch (25 mm) space shall be provided between the insulation and the roof sheathing and at the location of the vent.

Reason: This proposal is editorial and will bring the IRC requirements into alignment with the IBC ventilation requirements.

Cost Impact: Will not increase the cost of construction
The proposal is editorial and adds no additional requirements.

Report of Committee Action Hearings

Committee Action:

Approved as Submitted

Committee Reason: The committee approved this proposal based on the proponents published reason statement. This adds requirements to prevent the entry of vermin.

Assembly Action:

None

Final Action Results

RB323-16

AS

[←BACK](#)

Code Change No: **RB324-16**

Original Proposal

Section: R806.2

Proponent: Mike Fischer, Kellen, representing Asphalt Roofing Manufacturers Association (mfischer@kellencompany.com)

Revise as follows:

R806.2 Minimum vent area. The minimum net free ventilating area shall be $1/150$ of the area of the vented space.

Exception: The minimum net free ventilation area shall be $1/300$ of the vented space provided ~~one or more~~ both of the following conditions are met:

1. In Climate Zones 6, 7 and 8, a Class I or II vapor retarder is installed on the warm-in-winter side of the ceiling.
2. Not less than 40 percent and not more than 50 percent of the required ventilating area is provided by ventilators located in the upper portion of the attic or rafter space. Upper ventilators shall be located not more than 3 feet (914 mm) below the ridge or highest point of the space, measured vertically, with the balance of the required ventilation provided by eave or cornice vents. Where the location of wall or roof framing members conflicts with the installation of upper ventilators, installation more than 3 feet (914 mm) below the ridge or highest point of the space shall be permitted.

Reason: The proposal is a clarification to align the IRC with the IBC requirements for the reduction in ventilation area.

Cost Impact: Will increase the cost of construction

The proposal may increase the cost of construction due to additional requirements to reduce the net free vent area.

Report of Committee Action Hearings

Committee Action:

Approved as Submitted

Committee Reason: The committee approved this proposal based on the proponents published reason statement.

Assembly Action:

None

Final Action Results

RB324-16

AS

[←BACK](#)

Code Change No: **RB325-16**

Original Proposal

Section: R806.2**Proponent:** Kevin McOsker, representing Southern Nevada Chapter of ICC (ktm@ClarkCountyNV.gov)**Revise as follows:****R806.2 Minimum vent area.** The minimum net free ventilating area shall be $\frac{1}{150}$ of the area of the vented space.**Exception:** The minimum net free ventilation area shall be $\frac{1}{300}$ of the vented space provided one or more of the following conditions are met:

1. In Climate Zones 6, 7 and 8, a Class I or II vapor retarder is installed on the warm-in-winter side of the ceiling.
2. Not less than 40 percent and not more than 50 percent of the required ventilating area is provided by ventilators located in the upper portion of the attic or rafter space. Upper ventilators shall be located not more than 3 feet (914 mm) below the ridge or highest point of the space, measured vertically, with the balance of the required ventilation provided ~~by eave or cornice vents~~ shall be located in the bottom 1/3 of the attic space. Where the location of wall or roof framing members conflicts with the installation of upper ventilators, installation more than 3 feet (914 mm) below the ridge or highest point of the space shall be permitted.

Reason: Due to property line separation requirements, restricting the lower vents to the eave or cornice, may not be achievable. The intent of this change does not restrict the use of eave or cornice vents when they are located in the bottom 1/3 of the attic space. Installing ventilation at the bottom 1/3 of the attic space achieves similar cross ventilation effect as eave and cornice vents. Allowing the lower ventilators to be placed on the roof, allows the designer flexibility, without creating a conflict with Table R302.1(1) or R302.1(2), where opening may not be allowed.**Cost Impact:** Will not increase the cost of construction
Design flexibility will not increase costs.

Report of Committee Action Hearings

Committee Action:**Approved as Submitted****Committee Reason:** The committee approved this proposal based on the proponents published reason statement. This provides flexibility for the placement of the ventilation.**Assembly Action:****None**

Final Action Results

RB325-16**AS**

Code Change No: **RB326-16**

Original Proposal

Section: R806.5

Proponent: Craig Conner, representing self (craig.conner@mac.com)

Revise as follows:

R806.5 Unvented attic and unvented enclosed rafter assemblies. Unvented *attics* and unvented enclosed roof framing assemblies created by ceilings that are applied directly to the underside of the roof framing members and structural roof sheathing applied directly to the top of the roof framing members/rafters, shall be permitted where all the following conditions are met:

1. The unvented *attic* space is completely within the *building thermal envelope*.
2. No interior Class I vapor retarders are installed on the ceiling side (*attic* floor) of the unvented *attic* assembly or on the ceiling side of the unvented enclosed roof framing assembly.
3. Where wood shingles or shakes are used, a minimum 1/4-inch (6.4 mm) vented airspace separates the shingles or shakes and the roofing underlayment above the structural sheathing.
4. In Climate Zones 5, 6, 7 and 8, any *air-impermeable insulation* shall be a Class II vapor retarder, or shall have a Class II vapor retarder coating or covering in direct contact with the underside of the insulation.
5. Insulation shall be located in accordance with the following:
 - 5.1. Item 5.1.1, 5.1.2, 5.1.3 or 5.1.4 shall be met, depending on the air permeability of the insulation directly under the structural roof sheathing.
 - 5.1.1. Where only *air-impermeable insulation* is provided, it shall be applied in direct contact with the underside of the structural roof sheathing.
 - 5.1.2. Where *air-permeable insulation* is ~~provided inside the building thermal envelope, it shall be installed in accordance with Section 5.1.~~ In addition to the *air-permeable insulation* installed directly below the structural sheathing, rigid board or sheet insulation shall be installed directly above the structural roof sheathing in accordance with the *R*-values in Table R806.5 for condensation control.
 - 5.1.3. Where both *air-impermeable* and *air-permeable insulation* are provided, the *air-impermeable insulation* shall be applied in direct contact with the underside of the structural roof sheathing in accordance with Item 5.1.1 and shall be in accordance with the *R*-values in Table R806.5 for condensation control. The *air-permeable insulation* shall be installed directly under the *air-impermeable insulation*.
 - 5.1.4. Alternatively, sufficient rigid board or sheet insulation shall be installed directly above the structural roof sheathing to maintain the monthly average temperature of the underside of the structural roof sheathing above 45°F (7°C). For calculation purposes, an interior air temperature of 68°F (20°C) is assumed and the exterior air temperature is assumed to be the monthly average outside air temperature of the three coldest months.
 - 5.2. Where preformed insulation board is used as the *air-impermeable* insulation layer, it shall be sealed at the perimeter of each individual sheet interior surface to form a continuous layer.

Reason: This is an editorial improvement, which makes the code clearer. There is no change in the requirements.

Cost Impact: Will not increase the cost of construction
This clarifies the code.

**Report of Committee Action
Hearings**

Committee Action:

Approved as Submitted

Committee Reason: The committee approved this proposal based on the proponents published reason statement.

Assembly Action:

None

Final Action Results

RB326-16

AS

Code Change No: **RB327-16**

Original Proposal

Section: R202 (New), R806.5

Proponent: Craig Conner, representing self (craig.conner@mac.com); Joseph Lstiburek, representing self (joe@buildingscience.com)

Add new definition as follows:

Vapor Diffusion Port. A passageway for conveying water vapor from an unvented attic to the outside atmosphere.

Revise as follows:

R806.5 Unvented attic and unvented enclosed rafter assemblies. Unvented *attics* and unvented enclosed roof framing assemblies created by ceilings that are applied directly to the underside of the roof framing members and structural roof sheathing applied directly to the top of the roof framing members/rafters, shall be permitted where all the following conditions are met:

1. The unvented *attic* space is completely within the *building thermal envelope*.
2. No interior Class I vapor retarders are installed on the ceiling side (*attic* floor) of the unvented *attic* assembly or on the ceiling side of the unvented enclosed roof framing assembly.
3. Where wood shingles or shakes are used, a minimum 1/4-inch (6.4 mm) vented airspace separates the shingles or shakes and the roofing underlayment above the structural sheathing.
4. In Climate Zones 5, 6, 7 and 8, any *air-impermeable insulation* shall be a Class II vapor retarder, or shall have a Class II vapor retarder coating or covering in direct contact with the underside of the insulation.
5. Insulation shall ~~be located in accordance with the following with~~ comply with either 5.1 or 5.2, and additionally 5.3:
 - 5.1. Item 5.1.1, 5.1.2, 5.1.3 or 5.1.4 shall be met, depending on the air permeability of the insulation directly under the structural roof sheathing.
 - 5.1.1. Where only *air-impermeable insulation* is provided, it shall be applied in direct contact with the underside of the structural roof sheathing.
 - 5.1.2. Where *air-permeable insulation* is provided inside the building thermal envelope, it shall be installed in accordance with Section 5.1. In addition to the *air-permeable insulation* installed directly below the structural sheathing, rigid board or sheet insulation shall be installed directly above the structural roof sheathing in accordance with the *R*-values in Table R806.5 for condensation control.
 - 5.1.3. Where both *air-impermeable* and *air-permeable insulation* are provided, the *air-impermeable insulation* shall be applied in direct contact with the underside of the structural roof sheathing in accordance with Item 5.1.1 and shall be in accordance with the *R*-values in Table R806.5 for condensation control. The *air-permeable insulation* shall be installed directly under the *air-impermeable insulation*.
 - 5.1.4. Alternatively, sufficient rigid board or sheet insulation shall be installed directly above the structural roof sheathing to maintain the monthly average temperature of the underside of the structural roof sheathing above 45°F (7°C). For calculation purposes, an interior air temperature of 68°F (20°C) is assumed and the exterior air temperature is assumed to be the monthly average outside air temperature of the three coldest months.

- 5.2. In climate zones 1, 2, and 3 when air-permeable insulation is installed in unvented attics it shall meet the following requirements: 1) An *approved vapor diffusion port* shall be installed not more than 12 inches (305mm) from the highest point of the roof, measured vertically from the highest point of the roof to the lower edge of the port. 2) The port area shall be $\geq 1:600$ of the ceiling area. Where there are multiple ports in the attic, the sum of the port areas shall be greater than or equal to the area requirement. 3) The vapor permeable membrane in the *vapor diffusion port* shall have a vapor permeance rating of ≥ 20 perms when tested in accordance with Procedure A of ASTM E96. 4) The *vapor diffusion port* shall serve as an *air barrier* between the attic and the exterior of the building. 5) The *vapor diffusion port* shall protect the attic against the entrance of rain and snow. 6) Framing members and blocking shall not block the free flow of water vapor to the port. Not less than a 2-inch (50 mm) space shall be provided between any blocking and the roof sheathing. Air-permeable insulation shall be permitted within that space. 7) The roof slope shall be $\geq 3:12$ (vertical/horizontal). 8) Where only air-permeable insulation is used, it shall be installed directly below the structural roof sheathing. 9) Air-impermeable insulation, if any, shall be directly above or below the structural roof sheathing and is not required to meet the R-value in in table 806.5. When directly below the structural roof sheathing, there shall be no space between the air-impermeable and air-permeable insulation. 10) The air shall be supplied at a flow rate ≥ 50 CFM (23.6 L/s) per 1000 ft² of ceiling. The air shall be supplied from ductwork providing supply air to the occupiable space when the conditioning system is operating. Alternatively, the air shall be supplied by a supply fan when the conditioning system is operating.
- 5.3. Where preformed insulation board is used as the air-impermeable insulation layer, it shall be sealed at the perimeter of each individual sheet interior surface to form a continuous layer.

Reason: Unvented attic assemblies have a record of success. Unvented attic assemblies are most commonly constructed with spray polyurethane foam applied directly to the underside of the roof deck. This is a historically successful method of construction with over 20 years of experience. Another approach to unvented attic assemblies is to insulate over the top of the roof deck with rigid insulation boards.

The proposed code change allows the use of lower cost alternatives. Specifically, the proposed code change allows the use of fiberglass batts, blown cellulose and blown fiberglass to construct unvented attic assemblies. The approach is limited to Climate Zones 1, 2 and 3 based on research and historic experience over the past decade.

The proposed code change adds a vapor diffusion port/vent. The port acts as a moisture control measure, allowing moisture in the attic to be removed by vapor diffusion rather than by air change. This allows the attic assembly to remain airtight while providing a path for vapor moisture via vapor diffusion. Airtight attics also benefit energy efficiency.

This allows alternatives to rigid board and spray polyurethane foam. Alternatives provides more material choices for designers, builders and consumers who have issues with the greenhouse gas potential of blowing agents, impacts of fire retardants and off-gassing of some insulation products. Or just want to try a less expensive option.

Adding new unvented attic options to the existing options provides additional benefits. In high wildfire regions the elimination of eave vents and air sealing the upper attic vents at ridges reduces the entry of embers. In hurricane zones the elimination of roof vents reduces the entry of rainwater during hurricane events.

The research work supporting this code change is an outgrowth of the original research work supporting unvented attic assemblies started in 1995 under the Department of Energy's Building America Program. The same technical team and the same technical rigor that supported the original code changes for unvented attics in the early 2000's are behind this proposed code change.

The technical rationale and research behind this code change can be found at [Venting Vapor](#). For a history of conditioned attics, see [Cool Hand Luke Meets Attics](#). Here is the [technical data](#) and [more technical data](#) (link to research report at lower right of page on web site).

Cost Impact: Will not increase the cost of construction
This will provide options.

Report of Committee Action Hearings

Committee Action:

Approved as Submitted

Committee Reason: The committee approved this proposal based on the proponents published reason statement and there was no testimony from opponents that the science will not work. This adds a good option for unvented attics.

Assembly Action:

None

Final Action Results

RB327-16

AS

[←BACK](#)

Code Change No: **RB359-16**

Original Proposal

Section: R1005.8 (New)

Proponent: Gregg Achman, Hearth & Home Technologies, representing Hearth & Home Technologies (achmang@hearthnhome.com)

Add new text as follows:

R1005.8 Insulation shield. Where factory-built chimneys pass through insulated assemblies, an insulation shield constructed of steel having a minimum thickness of 0.0187 inch (0.4712 mm) (No. 26 gage) shall be installed to provide clearance between the chimney and the insulation material. The clearance shall not be less than the clearance to combustibles specified by the chimney manufacturer's installation instructions. Where chimneys pass through attic space, the shield shall terminate not less than 2 inches (51 mm) above the insulation materials and shall be secured in place to prevent displacement. Insulation shields provided as part of a listed chimney system shall be installed in accordance with the manufacturer's installation instructions.

Reason: The codes currently require insulation shields for vents to ensure proper clearance to insulation so as not to cause a fire hazard, the code should also require insulation shields for factory-built chimneys as they also require clearance to insulation and it represents a fire hazard when one is not installed.

Cost Impact: Will not increase the cost of construction

Will not increase cost as the insulation shield should already be used, however, when the code does not call it out as required many times it gets overlooked.

Report of Committee Action Hearings

Committee Action:

Approved as Submitted

Committee Reason: This proposal ensures proper clearances on a situation that we need to have guidance on.

Assembly Action:

None

Final Action Results

RB359-16

AS

Code Change No: **RB360-16**

Original Proposal

Section: AE101.1, AE101.2 (New)

Proponent: Gregory Wilson, Federal Emergency Management Agency, representing Federal Emergency Management Agency (gregory.wilson2@fema.dhs.gov); Rebecca Quinn, RCQuinn Consulting, Inc. (rcquinn@earthlink.net)

Revise as follows:

AE101.1 General. These provisions shall be applicable only to a *manufactured home* used as a single *dwelling unit* installed on privately owned (nonrental) lots and shall apply to the following:

1. Construction, *alteration* and repair of any foundation system that is necessary to provide for the installation of a *manufactured home* unit.
2. Construction, installation, *addition*, *alteration*, repair or maintenance of the building service *equipment* that is necessary for connecting *manufactured homes* to water, fuel, or power supplies and sewage systems.
3. *Alterations*, *additions* or repairs to existing *manufactured homes*. The construction, *alteration*, moving, demolition, repair and use of accessory buildings and structures, and their building service *equipment*, shall comply with the requirements of the codes adopted by this *jurisdiction*.

These provisions shall not be applicable to the design and construction of *manufactured homes* and shall not be deemed to authorize either modifications or *additions* to *manufactured homes* where otherwise prohibited.

Exception: In addition to these provisions, new and replacement *manufactured homes* to be located in flood hazard areas as established in Table R301.2(1) of the *International Residential Code* shall meet the applicable requirements of Section R322 of the *International Residential Code*.

Add new text as follows:

AE101.2 Flood hazard areas. New and replacement *manufactured homes* to be installed in flood hazard areas as established in Table R301.2(1) of the *International Residential Code* shall also meet the applicable requirements of Section R322 of the *International Residential Code*.

Reason: This proposal is editorial. The text current in an exception should be a separate section. It is not good code writing to have an exception written to add to the basic requirement.

Cost Impact: Will not increase the cost of construction
Proposal only clarifies and puts the provision in proper format.

Report of Committee Action Hearings

Committee Action:

Approved as Submitted

Committee Reason: The proposal makes a useful editorial clarification.

Assembly Action:

None

Final Action Results

RB360-16

AS

Code Change No: **RB365-16**

Original Proposal

Section: 202, AR101, AR101.1, AR102, AR102.1, AR103, AR103.1, AR103.2, AR103.2.1, AR103.2.2, AR103.2.3, AR103.2.3 (New), AR103.2.4, AR103.2.4(1) (New), AR103.2.4(2) (New), AR103.2.4(3) (New), AR103.3, AR103.3.1, AR103.3.2, AR103.3.3, AR103.3.4, AR103.4, AR103.4.1, AR103.4.2, AR103.4.3, AR103.4.4, AR103.4.5, AR103.4.6, AR103.4.7, AR103.5, AR103.5.1, AR103.5.2, AR103.5.3, AR103.5.4, AR103.5.5, AR104, AR104.1, AR104.2 (New), AR105

Proponent: Lou Host-Jablonski, Design Coalition, Inc., representing Design Coalition, Inc. and StrawClay.org (lou@designcoalition.org); Scott Cherry, representing Lightfoot inc. (scott@lightfootinc.com); Douglas Piltingsrud, Design Coalition Institute, Inc., representing Sustainable Housing Research, LLC (dougiltingsrud@gmail.com); Richie Duncan, Kodama Zomes LLC, representing self (richie@kodamazomes.com); Paula Baker-Laporte, representing Econest Architecture Inc. (paula@econest.com); Martin Hammer, representing Martin Hammer, Architect (mfhammer@pacbell.net); Robert Laporte, representing EcoNest Company (robert@econest.com); Susan Thering, representing Design Coalition Institute Inc.; Jacob Racusin, New Frameworks Natural Design/Build, representing New Frameworks Natural Design/Build (jacob@newframeworks.com)

Revise as follows:

AR101.1 Scope. This appendix shall govern the use of light straw-clay as a nonbearing building material and wall infill system in Seismic Design Categories A and B. Use of light straw-clay in Seismic Design Categories C, D₀, D₁ and D₂ shall require an approved engineered design by a registered design professional in accordance with Section R301.1.3.

SECTION AR102 DEFINITIONS

AR102.1 General. The following words and terms shall, for the purposes of this appendix, have the meanings shown herein. Refer to Chapter 2 of the *International Residential Code* for general definitions.

CLAY. Inorganic soil with particle sizes of less than 0.00008 inch (0.002 mm) having the characteristics of high to very high dry strength and medium to high plasticity.

CLAY SLIP. A suspension of clay ~~soil~~ subsoil in water.

CLAY SOILSUBSOIL. ~~Inorganic soil~~ Subsoil sourced directly from the earth or refined, containing 50 percent or more clay by volume and free of organic matter.

INFILL. Light straw-clay that is placed between the structural and nonstructural members of a building.

LIGHT STRAW-CLAY. A mixture of straw and clay slip compacted and dried to form insulation and plaster substrate between or around structural and nonstructural members in a wall.

NONBEARING. Not bearing the weight of the building other than the weight of the light straw-clay itself and its finish.

STRAW. The dry stems of cereal grains after the seed heads have been removed.

VOID. Any space in a light straw-clay wall wider than 1/4 inch (6mm), greater than 2 inches (51 mm) in which a 2-inch horizontal length and greater than 2 inches (51 mm) sphere can be inserted in depth.

SECTION AR103 NONBEARING LIGHT STRAW-CLAY CONSTRUCTION

AR103.1 General. Light straw-clay shall be limited to infill between or around structural and nonstructural wall framing members.

AR103.2 Structure. The structure of buildings using light straw-clay shall be in accordance with the *International Residential Code* or shall be in accordance with an *approved* design by a registered *design professional*.

AR103.2.1 Number of stories. Use of light straw-clay infill shall be limited to buildings that are not more than one *story above grade plane*.

Exception: Buildings using light straw-clay infill that are greater than one *story above grade plane* shall be in accordance with an *approved* design by a registered *design professional*.

AR103.2.2 Bracing. ~~Wind bracing~~ Bracing for buildings with light straw-clay infill shall be in accordance with Section R602.10 and ~~shall use Method LIB.~~ Walls with light straw-clay infill shall use Method LIB and shall not be sheathed with solid sheathing. Walls without light straw-clay infill shall comply with any bracing method prescribed by this code.

AR103.2.3 Weight Requirements and properties of light straw-clay mixtures. Light The requirements and properties of light straw-clay mixtures shall be ~~deemed to have a design dead load of 40 pounds per cubic foot (640 kg per cubic meter) unless otherwise demonstrated to the building official~~ in accordance with Table AR103.2.3.

AR103.2.4 ReinforcementStabilization of light straw-clay. Light straw-clay shall be ~~reinforced~~ stabilized as follows, or shall be in accordance with an approved design by a registered design professional:

1. ~~Vertical reinforcing shall be not less than nominal 2-inch by 6-inch (51 mm by 152 mm) wood members at not more than 32 inches (813 mm) on center where the vertical reinforcing is nonload bearing and at 24 inches (610 mm) on center where it is load bearing. The vertical reinforcing shall not exceed an unrestrained height of 10 feet (3048 mm) and shall be attached at top and bottom in accordance with Chapter 6 of the this code. In lieu of these requirements, vertical reinforcing shall be in accordance with an approved design by a registered design professional.~~
2. ~~Horizontal reinforcing shall be installed in the center of the wall at not more than 24 inches (610 mm) on center and shall be secured to vertical members. Horizontal reinforcing shall be of any of the following: 3/4-inch (19.1 mm) bamboo, 1/2-inch (12.7 mm) fiberglass rod, 1-inch (25 mm) wood dowel or nominal 1-inch by 2-inch (25 mm by 51 mm) wood.~~
3. Vertical stabilization shall be of structural or nonstructural wood framing in accordance with Figures AR103.2.4(1), AR103.2.4(2) or AR103.2.4(3). Such framing members shall not be prohibited to be both load-bearing and stabilization members where they meet the requirements of Section R602 and this section. Nonstructural stabilization members shall be not more than 32 inches (813mm) on center.
4. Horizontal stabilization shall be installed at not more than 24 inches (610 mm) on center and in accordance with Figures AR103.2.4(1), AR103.2.4(2) or AR103.2.4(3). Horizontal stabilization shall be of any of the following with the stated minimum dimensions: 3/4-inch (19.1 mm) bamboo, 1/2-inch (12.7 mm) fiberglass rod, 1-inch (25 mm) wood dowel or nominal 1-inch by 2-inch (25 mm by 51 mm) wood.

AR103.3 Materials. The materials used in light straw-clay construction shall be in accordance with Sections AR103.3.1 through AR103.3.4 ~~AR103.3.3~~.

AR103.3.1 Straw requirements. Straw shall be stems of wheat, rye, oats, rice or barley, and shall be free of visible decay, insects and ~~insects~~ green plant material.

AR103.3.2 Clay soil-subsoil requirements. Suitability of clay ~~soil~~ subsoil shall be determined in accordance with the ~~Figure 2 Ribbon Test or the Figure 3 Ball Test of the Appendix to ASTM E 2392/ E 2392M~~ Table AR103.2.3.

Delete without substitution:

~~**AR103.3.3 Clay slip.** Clay slip shall be of sufficient viscosity such that a finger dipped in the slip and withdrawn remains coated with an opaque coating.~~

Revise as follows:

~~**AR103.3.4 AR103.3.3 Light straw-clay mixture.** Light-A light straw-clay mixture shall contain not less than 65 percent and not more than 85 percent straw, by volume consist of bale compacted loose straw to clay soil. Loose straw shall be mixed and coated with clay slip such that there is not more than 5 percent uncoated straw and shall be in accordance with Table AR103.2.3.~~

AR103.4 Wall construction. Light straw-clay wall construction shall be in accordance with the requirements of Sections AR103.4.1 through AR103.4.7.

AR103.4.1 Light straw-clay maximum thickness. ~~Light~~The maximum thickness of light straw-clay shall be not more than 12 inches (305 mm) thick, to allow adequate drying of the installed material in accordance with Table AR103.2.3.

AR103.4.2 Distance above grade. Light straw-clay and its exterior finish shall be not less than 8 inches (203 mm) above exterior finished *grade*.

AR103.4.3 Moisture barrier. An *approved* moisture barrier shall separate the bottom of light straw-clay walls from any masonry or concrete foundation or slab that directly supports the walls. Penetrations and joints in the barrier shall be sealed with an *approved* sealant.

AR103.4.4 Contact with wood members. Light straw-clay shall be permitted to be in contact with untreated wood members.

AR103.4.5 Contact with nonwood structural members. Nonwood structural members in contact with light straw-clay shall be resistant to corrosion or shall be coated to prevent corrosion with an *approved* coating.

AR103.4.6 Installation. Light straw-clay shall be installed in accordance with the following:

1. Formwork shall be sufficiently strong to resist bowing where the light straw-clay is compacted into the forms.
2. Light straw-clay shall be uniformly placed into forms and evenly tamped to achieve stable walls free of voids. Light straw-clay shall be placed in lifts of not more than 6 inches (152 mm) and shall be thoroughly tamped before additional material is added.
3. ~~Formwork~~ Temporary formwork shall be removed from walls within 24 hours after tamping, and walls shall remain exposed until moisture content is in accordance with Section AR103.5.1. Visible voids shall be ~~patched~~ filled with light straw-clay or other insulative material prior to plastering.

AR103.4.7 Openings in walls. Openings in walls shall be in accordance with the following:

1. Rough framing for doors and windows shall be fastened to structural members in accordance with the *International Residential Code*. Windows and doors shall be flashed in accordance with the *International Residential Code*.
2. An *approved* moisture barrier shall be installed at window sills in light straw-clay walls prior to installation of windows.

AR103.5 Wall finishes. The interior and exterior surfaces of light straw-clay walls shall be protected with a finish in accordance with Sections AR103.5.1 through AR103.5.5.

AR103.5.1 ~~Moisture content~~ Dimensional stability of light straw-clay prior to application of plaster finish. Light straw-clay walls-infill having a density of 30 pounds per cubic foot (480.6 kg/m³) or greater shall be dry to a moisture content of not more than 20 percent at a depth of 4 inches (102 mm), as measured from each side of the wall, ~~prior to~~. Light straw-clay infill having a density of less than 30 pounds per cubic foot (480.6 kg/m³) shall be sufficiently dry such that the application of finish on either side-overall shrinkage of the wall. Moisture content shall be measured with a moisture meter equipped with a probe that light straw-clay is designed for use with baled straw or hay dimensionally stable.

AR103.5.2 Plaster finish. Exterior plaster ~~finishes~~ shall be clay plaster ~~plasters~~ or lime plaster ~~plasters~~. Interior plaster ~~finishes~~ ~~plasters~~ shall be clay plaster ~~plasters~~, lime plaster ~~plasters~~ or gypsum plaster ~~plasters~~. Plasters shall be permitted to be applied directly to the surface of the light straw-clay walls without reinforcement, except that the juncture of dissimilar substrates shall be in accordance with Section AR103.5.4. Plasters shall have a thickness of not less than 1/2 inch (12.7 mm) and not more than 1 inch (25 mm) and shall be installed in not less than two coats. ~~Exterior Rain-exposed~~ clay plaster ~~plasters~~ shall be finished with a lime-based or silicate-mineral coating.

AR103.5.3 Separation of wood and plaster. Where wood framing occurs in light straw-clay walls, such wood surfaces shall be separated from exterior plaster with No.15 asphalt felt, Grade D paper or other approved material except where the wood is preservative treated or naturally durable.

Exception: Exterior clay plasters shall not be required to be separated from wood.

AR103.5.4 Bridging across dissimilar substrates. Bridging shall be installed across dissimilar substrates prior to the application of plaster. Acceptable bridging materials include: expanded metal lath, woven wire mesh, welded wire mesh, fiberglass mesh, reed matting or burlap. Bridging shall extend not less than 4 inches (102 mm), on both sides of the juncture.

AR103.5.5 Exterior siding-cladding. Exterior ~~wood, metal or composite material siding-cladding~~ shall be spaced not less than 1/2³/₄ inch (19.1 mm) from the light straw-clay such that a ventilation space is created to allow for moisture diffusion. Furring strips that create this ventilation space shall be securely fastened to the stabilization members or framing. The siding-cladding shall be fastened to the wood furring strips in accordance with the manufacturer's instructions. Furring strips shall be spaced not more than 32 inches (813 mm) on center, and shall be securely fastened to the vertical wall reinforcing or structural framing. Insect screening shall be provided at the top and bottom of the ventilation space. An air barrier consisting of not more than 3³/₈ inch thick (9.5 mm) clay plaster or lime plaster shall be applied to the light straw-clay prior to the application of siding.

SECTION AR104 THERMAL INSULATION PERFORMANCE

AR104.1 R-value-Thermal characteristics. ~~Light Walls with light straw-clay, where installed infill of densities of greater than or equal to 20 pounds per cubic foot (480.6 kg/m³) shall be classified as mass walls in accordance with this appendix, Section N1102.2.5 and shall be deemed to have an R-value meet the R-value requirements for mass walls in Table N1102.1.2 (R402.1.2). Walls with light straw-clay infill of 4-6 densities less than 20 pounds per cubic foot (480.6 kg/m³) shall meet the R-value requirements for wood frame walls in Table N1102.1.1 (R402.1.2).~~

AR104.2 Thermal resistance. Light straw-clay shall be deemed to have a thermal resistance as specified in Table AR103.2.3.

Delete without substitution:

**SECTION AR105-
REFERENCED STANDARD**

ASTM E
2392/ E Standard Guide for Design of
2392M—10 Earthen Wall Building Systems AR103.3.2

**TABLE AR103.2.3
REQUIREMENTS AND PROPERTIES OF LIGHT STRAW-CLAY MIXTURES ^a**

Density (pcf)	Straw (pcf)	Subsoil (pcf)	Water (gal/cf) ^b	Min. % Clay in Subsoil	Min. Clay:Silt Ratio	Subsoil Testing Method ^{c,d}	Max. Wall Thickness, inches	R-Value (hr/F°/cf/BTU/inch)
<u>10</u>	<u>6.7</u>	<u>3.3</u>	<u>1.55</u>	<u>70</u>	<u>3.5:1</u>	<u>A</u>	<u>15</u>	<u>1.80</u>
<u>12</u>	<u>6.7</u>	<u>5.3</u>	<u>1.63</u>	<u>46</u>	<u>1.7:1</u>	<u>A</u>	<u>15</u>	<u>1.72</u>
<u>13</u>	<u>6.7</u>	<u>6.3</u>	<u>1.67</u>	<u>40</u>	<u>1.33:1</u>	<u>A</u>	<u>15</u>	<u>1.69</u>
<u>15</u>	<u>6.7</u>	<u>8.3</u>	<u>1.74</u>	<u>35</u>	<u>0.95:1</u>	<u>A</u>	<u>15</u>	<u>1.63</u>
<u>20</u>	<u>6.7</u>	<u>13.3</u>	<u>1.93</u>	<u>30</u>	<u>0.60:1</u>	<u>A</u>	<u>12</u>	<u>1.48</u>
<u>30</u>	<u>6.7</u>	<u>23.3</u>	<u>2.31</u>	<u>NA</u>	<u>NA</u>	<u>B</u>	<u>12</u>	<u>1.22</u>
<u>40</u>	<u>6.7</u>	<u>33.3</u>	<u>2.70</u>	<u>NA</u>	<u>NA</u>	<u>B</u>	<u>12</u>	<u>1.01</u>
<u>50</u>	<u>6.7</u>	<u>43.3</u>	<u>3.08</u>	<u>NA</u>	<u>NA</u>	<u>B</u>	<u>12</u>	<u>0.84</u>

© Douglas Piltingsrud and StrawClay.org. Used by permission.

a. Interpolation permitted. Extrapolation not permitted.

b. Water mixed with subsoil equals clay slip.

c. Subsoil Testing Methods:

A. Lab test for percent of clay, silt and sand via hydrometer method.

B. Ribbon Test of the Figure 3 Ball Test in the Appendix of ASTM E2392/E2392M.

d. Trace amounts of organic materials are acceptable.

**FIGURE AR103.2.4(1)
LIGHT STRAW-CLAY WALL WITH LARSEN TRUSSES**

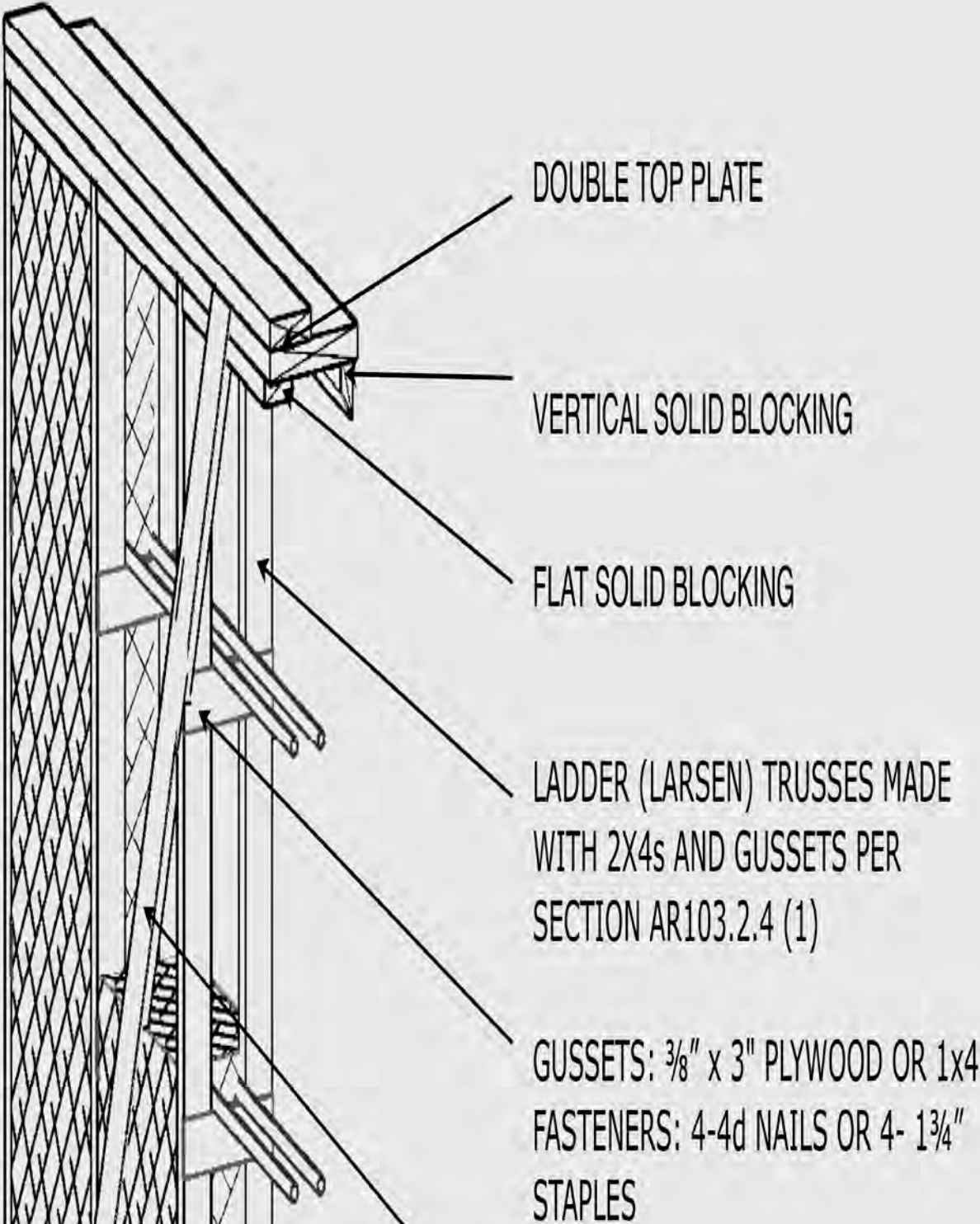


FIGURE AR103.2.4(2)
LIGHT STRAW-CLAY WALL SINGLE STUD WIDTH

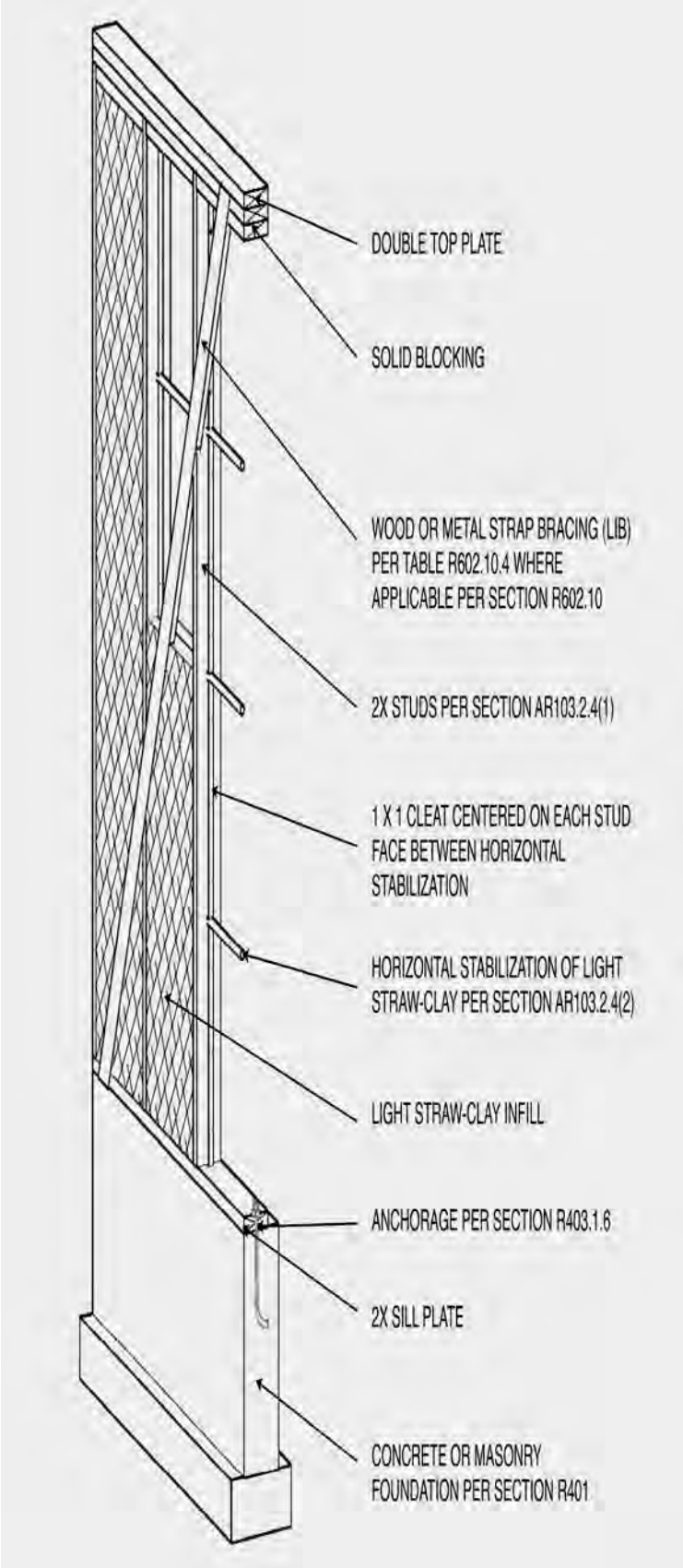
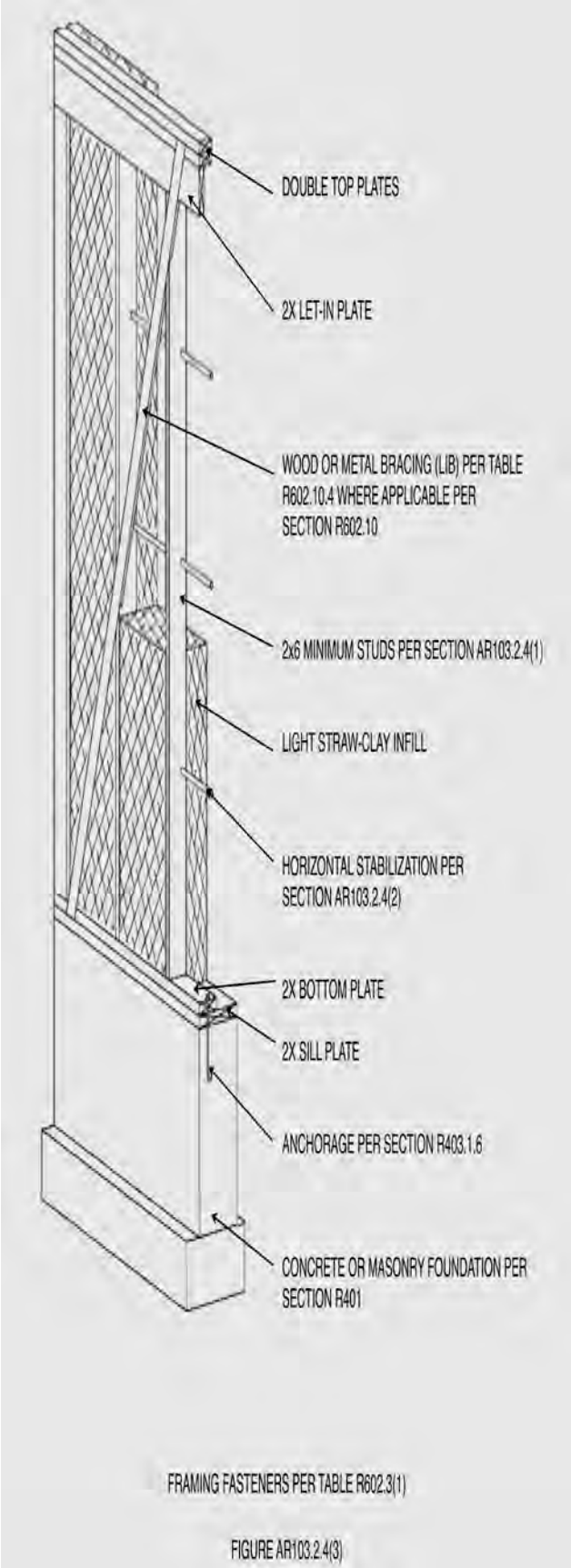


FIGURE AR103.2.4(3)
LIGHT STRAW-CLAY WALL WITH BLIND STUDS



Reason: Summary/Abstract: Updates to Appendix R Light Straw Clay Construction will provide clarification and incorporate new scientific information regarding material performance and construction methodology. This proposal adds new Figures and a Table, information previously published in the 2015 IRC Commentary Appendix R, and proposes text changes to certain Sections to coordinate with same.

Scope: Proposed additional text clarifies the scope of structural design requirements in seismic design zones.

Definitions: Several definitions are updated to be more accurate and congruent with other sections of this Appendix.

Bracing: Proposed text clarifies that lateral bracing at light straw-clay infill is confined to method LIB and solid sheathing is not allowed, but that other wall types within a building that do not use light straw-clay infill are permitted to use any bracing allowed in the code.

Table: Proposed Table is introduced. Further scientific testing has yielded data to more fully define light straw-clay materials and characteristics. Table AR103.2.3 covers the range of the requirements and properties of light straw-clay infill without limiting it to single specific weight. Text changes in subsequent sections refer to and coordinate with the new table.

Stabilization: Proposed substitution of the term 'stabilization' in lieu of 'reinforcement' as used previously. This clarifies the role of this element in light straw-clay construction, acknowledging that the term 'reinforcement' in construction is generally more commonly associated with the structural reinforcement of concrete.

The purpose of the stabilizing elements in light straw-clay infill is to ensure overall wall dimensional stability and to transfer out-of-plane lateral loads to structural members; not, as in concrete practice, the way steel reinforcing is used to impart tensile strength to the material. The use of the term stabilization here more accurately describes the functioning of the required vertical and horizontal members.

In addition, the introduction of three Figures previously included in the Appendix R 2015 Commentary serves to visually illustrate this stabilization and communicate its function more clearly.

Plaster: Proposed text distinguishes between densities of light straw-clay infill and creates requirements for evaluating the dimensional stability of the infill prior to plastering, appropriate to density of the infill.

Thermal: Performance of the wall thermally is outlined by proposed new table AR103.2.3 for varying densities, correlated to R-value. Table and text also clarify the design densities regulated distinctly as wood frame and as mass walls.

Where this 2015 Section currently provides a one-size-fits-all thermal definition, the proposed changes provide updated data that reflects further scientific tests and the advancement of construction techniques. Previously, the information in the proposed Table AR103.2.3 was available only in the Appendix R 2015 Commentary.

Proponents: The proposed changes are presented by a collaboration of North America's most experienced light straw-clay practitioners, representing over 2 decades of active research, design and construction of light straw-clay buildings across climate zones in Canada and the U.S. The team includes 3 architects, 2 builders, a structural engineer and a building materials scientist, and this proposal incorporates input from multiple other practitioners.

Bibliography: Econest—Creating Sustainable Sanctuaries of Clay, Straw and Timber. Paula Baker-Laporte, FAIA and Robert Laporte. Layton, UT: Gibbs Smith, 2005.

Resistance to Out-Of-Plane Lateral Forces of Light Straw Clay Wall Infill. Richard Duncan, PE.

http://www.econesthomes.com/wp-content/uploads/2013/01/Light-Straw-Clay-Out-of-Plane-Study-FINAL_merged.pdf, 2013.

Typical Outline Specifications for a Northern Light Straw-Clay House; The Affordable Natural House Contractor Training Reference Manual, 2nd Edition. Lou Host-Jablonski, AIA; Susan Thering, PhD, ed. Madison WI: University of Wisconsin-Extension, 2008.

An Introduction to the Science of Northern Light Straw-Clay Construction; The Affordable Natural House Contractor Training Reference Manual, 2nd Edition. Douglas Piltingsrud, PhD and Lou Host-Jablonski, AIA; Susan Thering, PhD, ed. Madison, WI: University of Wisconsin-Extension. 2008.

State of New Mexico Construction Industries Division Clay Straw Guidelines. Santa Fe, NM: State of NM CID publication. 2001.

StrawClay.org website. Madison, Wisconsin: Design Coalition, Inc., 2016.

USDA Forest Products Laboratory Engineering Report of Light Clay Specimens: Thermal Conductivities for Design Coalition's Straw/Clay Formulations Extend Volhard's K-Value vs. Density Curve in Low Conductivity End. Madison WI: USDA Forest Products Laboratory. 2004.

Initial Material Characterization of Straw Light Clay. Joshua Thornton. Ottawa, Ontario. Canada Mortgage and Housing Corporation, 2004.

2011 Oregon Reach Code—Section 1307. Country Club Hills, IL: International Code Council, Inc., 2012.

The EcoNest Home: Designing and Bulding a Light Straw Clay House. Paula Baker-Laporte, FAIA and Robert Laporte. BC, Canada 2015. New Society Publishers

Cost Impact: Will not increase the cost of construction

The changes proposed do not affect or change the cost of the design or construction of Light Straw-Clay from the existing 2015 IRC code.

**Report of Committee Action
Hearings**

Committee Action:

Approved as Submitted

Committee Reason: This proposal cleans up many items, including improving the thermal mass provisions to provide more exact calculations.

Assembly Action:

None

Final Action Results

RB365-16

AS

[←BACK](#)

Code Change No: **RB366-16**

Original Proposal

Section: AS101.1, AS102.1, AS103.4, AS103.5, AS104.4.5, AS104.4.6, AS104.4.8, AS105.2, AS105.4, AS105.4.1, AS105.4.2, AS105.6.4, AS105.6.8, AS105.8 (New), AS106.11, AS106.12, AS106.13, AS106.13.1, AS106.5

Proponent: Martin Hammer, representing Martin Hammer, Architect (mfhammer@pacbell.net); Mark Aschheim, Santa Clara University, representing Santa Clara University (maschheim@scu.edu); David Eisenberg, Development Center for Appropriate Technology, representing Development Center for Appropriate Technology (strawnet@gmail.com); Jacob Racusin, New Frameworks Natural Design/Build, representing New Frameworks Natural Design/Build (jacob@newframeworks.com)

Revise as follows:

AS101.1 Scope. This appendix provides prescriptive and performance-based requirements for the use of baled straw as a building material. Other methods of strawbale construction shall be subject to approval in accordance with Section 104.11 of this code. Buildings using strawbale walls shall comply with ~~the~~ this code except as otherwise stated in this appendix.

AS102.1 Definitions. The following words and terms shall, for the purposes of this appendix, have the meanings shown herein. Refer to Chapter 2 of the *International Residential Code* for general definitions.

BALE. Equivalent to straw bale.

CLAY. Inorganic soil with particle sizes less than 0.00008 inch (0.002 mm) having the characteristics of high to very high dry strength and medium to high plasticity.

CLAY SLIP. A suspension of clay particles in water.

FINISH. Completed compilation of materials on the interior or exterior faces of stacked *bales*.

FLAKE. An intact section of compressed *straw* removed from an untied *bale*.

LAI D FLAT. The orientation of a bale with its largest faces horizontal, its longest dimension parallel with the wall plane, its *ties* concealed in the unfinished wall and its *straw* lengths oriented predominantly across the thickness of the wall.

LOAD-BEARING WALL. A strawbale wall that supports more than 100 pounds per linear foot (1459 N/m) of vertical load in addition its own weight.

MESH. An openwork fabric of linked strands of metal, plastic, or natural or synthetic fiber, ~~embedded in plaster.~~

NONSTRUCTURAL WALL. Walls other than load-bearing walls or shear walls.

ON-EDGE. The orientation of a *bale* with its largest faces vertical, its longest dimension parallel with the wall plane, its *ties* on the face of the wall and its *straw* lengths oriented predominantly vertically.

PIN. A vertical metal rod, wood dowel or bamboo, driven into the center of stacked bales, or placed on opposite surfaces of stacked bales and through-tied.

PLASTER. Gypsum ~~or plaster~~, cement plaster, ~~as defined in Sections R702 and AS104~~, or clay plaster, soil-cement plaster, lime plaster or cement-lime plaster as ~~defined~~ described in Section AS104.

PRECOMPRESSION. Vertical compression of stacked bales before the application of finish.

REINFORCED PLASTER. A plaster containing mesh reinforcement.

RUNNING BOND. The placement of *straw bales* such that the head joints in successive courses are offset not less than one-quarter the bale length.

SHEAR WALL. A strawbale wall designed and constructed to resist lateral seismic and wind forces parallel to the plane of the wall in accordance with Section AS106.13.

SKIN. The compilation of plaster and reinforcing, if any, applied to the surface of stacked bales.

STRUCTURAL WALL. A wall that meets the definition for a load-bearing wall or shear wall.

STACK BOND. The placement of straw bales such that head joints in successive courses are vertically aligned.

STRAW. The dry stems of cereal grains after the seed heads have been removed.

STRAW BALE. A rectangular compressed block of straw, bound by ties.

STRAWBALE. The adjective form of straw bale.

STRAW-CLAY. Loose straw mixed and coated with clay slip.

TIE. A synthetic fiber, natural fiber or metal wire used to confine a straw bale.

TRUTH WINDOW. An area of a strawbale wall left without its finish, to allow view of the straw otherwise concealed by its finish.

AS103.4 Moisture content. The moisture content of bales at the time of application of the first coat of plaster or the installation of another finish shall not exceed 20 percent of the weight of the bale. The moisture content of bales shall be determined ~~by use of~~ with a moisture meter designed for use with baled straw or hay, equipped with a probe of sufficient length to reach the center of the bale. Not less than 5 percent and not less than 10 bales ~~used~~ shall be randomly selected and tested.

AS103.5 Density. Bales shall have a dry density of not less than 6.5 pounds per cubic foot (104 kg/cubic meter). The dry density shall be calculated by subtracting the weight of the moisture in pounds (kg) from the actual bale weight and dividing by the volume of the bale in cubic feet (cubic meters). Not less than 2 percent and not less than five bales ~~to be used~~ shall be randomly selected and tested on site.

AS104.4.5 Gypsum plaster. Gypsum plaster shall comply with Section ~~R702~~ R702.2.1. Gypsum plaster shall be limited to use on interior surfaces of nonstructural walls, and as an interior finish coat over a structural plaster that complies with this appendix.

AS104.4.6 Lime plaster. Lime plaster shall comply with Sections AS104.4.6.1 ~~and through~~ AS104.4.6.3.

AS104.4.8 Cement plaster. Cement plaster shall conform to ASTM C 926 and shall comply with Sections ~~R703.6.2, R703.6.4~~ R703.7.4 and ~~R703.6.5~~ R703.7.5, except that the amount of lime in plaster coats shall be not less than 1 part lime to 6 parts cement to allow a minimum acceptable vapor permeability. The combined thickness of plaster coats shall be not more than 1¹/₂ inches (38 mm) thick.

AS105.2 Building limitations and requirements for use of strawbale nonstructural walls. Buildings using strawbale nonstructural walls shall be subject to the following limitations and requirements:

1. Number of stories: not more than one, except that two stories shall be allowed with an *approved* engineered design.
2. Building height: not more than 25 feet (7620 mm), except that greater heights shall be allowed with an *approved* engineered design.
3. Wall height: in accordance with Table AS105.4.
4. ~~Braced wall panel length, and increase in Seismic Design Categories C, D₀, D₁ and D₂: the required length of bracing for buildings using strawbale nonstructural walls shall comply with Section R602.10.3 of this code, with the additional requirements that Table 602.10.3(3) shall be applicable to buildings in Seismic Design Category C, and that the minimum total length of braced wall panels in Table R602.10.3(3) shall be increased by 60 percent.~~
5. Braced wall panel lengths: in accordance with Section R602.10.3, with the additional requirements that Table R602.10.3(3) shall apply to all buildings in Seismic Design Category C, and that the minimum total length of braced wall panels in Table R602.10.3(3) shall be increased by 60 percent for buildings in Seismic Design Categories C, D₀, D₁ and D₂.

AS105.4 Out-of-plane resistance methods and unrestrained wall dimensions-dimension limits. Strawbale walls shall employ a method of out-of-plane load resistance in accordance with Table AS105.4, and comply with its associated limits and requirements.

AS105.4.1 Determination of out-of-plane loading. Out-of-plane loading for the use of Table AS105.4 shall be in terms of the ultimate design wind speed and seismic design category as determined in accordance with Sections R301.2.1 and R301.2.2 ~~of this code.~~

**TABLE AS105.4
OUT-OF-PLANE RESISTANCE METHODS AND UNRESTRAINED WALL DIMENSIONS-DIMENSION LIMITS**

METHOD OF OUT-OF-PLANE <u>LOAD RESISTANCE</u> ^a	FOR <u>ULTIMATE DESIGN WIND DESIGN SPEEDS</u> (mph)	FOR SEISMIC DESIGN CATEGORIES	UNRESTRAINED WALL DIMENSIONS, H ^b		MESH STAPLE SPACING AT BOUNDARY RESTRAINTS
			Absolute limit in feet	Limit based on bale thickness T ^c in feet (mm)	
Nonplaster finish or unreinforced plaster	≤ 400 <u>130</u>	A, B, C, D ₀	H ≤ 8	H ≤ 5T	None required
Pins per Section AS105.4.2	≤400 <u>130</u>	A, B, C, D ₀	H ≤ 12	H ≤ 8T	None required
Pins per Section AS105.4.2	≤ 440 <u>140</u>	A, B, C, D ₀ , D ₁ , D ₂	H ≤ 10	H ≤ 7T	None required
Reinforced ^{ed} clay plaster	≤ 440 <u>140</u>	A, B, C, D ₀ , D ₁ , D ₂	H ≤ 10	$H \leq 8T^{0.5} (H \leq 140T^{0.5})$	≤ 6 inches
Reinforced ^{ed} clay plaster	≤ 440 <u>140</u>	A, B, C, D ₀ , D ₁ , D ₂	10 H ≤ 12	$H \leq 8T^{0.5} (H \leq 140T^{0.5})$	≤ 4 inches ^e
Reinforced ^{ed} cement, cement-lime, lime or soil-cement plaster	≤ 440 <u>140</u>	A, B, C, D ₀ , D ₁ , D ₂	H ≤ 10	$H \leq 9T^{0.5} (H \leq 157T^{0.5})$	≤ 6 inches
Reinforced ^{ed} cement, cement-lime, lime or soil-cement plaster	≤ 420 <u>155</u>	A, B, C, D ₀ , D ₁ , D ₂	H ≤ 12	$H \leq 9T^{0.5} (H \leq 157T^{0.5})$	≤ 4 inches ^e

For SI: 1 inch = 25.4 mm, 1 foot = 304.8 mm.

- Finishes applied to both sides of stacked bales. Where different finishes are used on opposite sides of a wall, the more restrictive requirements shall apply.
- H = Stacked bale height in feet (mm) between sill plate and top plate or other *approved* horizontal restraint, or the horizontal distance in feet (mm) between *approved* vertical restraints. For load-bearing walls, H refers to vertical height only.
- T = Bale thickness in feet (mm).

- d. Plaster reinforcement shall be any mesh allowed in Table AS106.16 for the matching plaster type, and with staple spacing in accordance with this table. Mesh shall be installed in accordance with Section AS106.9.
- e. Sill plate attachment shall be with $\frac{5}{8}$ -inch anchor bolts or approved equivalent at not more than 48 inches on center where staple spacing is required to be ≤ 4 inches

AS105.4.2 Pins. Pins used for out-of-plane resistance shall comply with the following or shall be in accordance with an *approved* engineered design. Pins shall be external, internal or a combination of the two.

1. Pins shall be $\frac{1}{2}$ -inch-diameter (12.7 mm) steel, $\frac{3}{4}$ -inch-diameter (19.1 mm) wood or $\frac{1}{2}$ -inch-diameter (12.7 mm) bamboo.
2. External pins shall be installed vertically on both sides of the wall at a spacing of not more than 24 inches (610 mm) on center. External pins shall have full lateral bearing on the sill plate and the top plate or roof-bearing element, and shall be tightly tied through the wall to an opposing pin with ties spaced not more than 32 inches (813 mm) apart and not more than 8 inches (203 mm) from each end of the pins.
3. Internal pins shall be installed vertically within the center third of the bales, at spacing of not more than 24 inches (610 mm) and shall extend from top course to bottom course. The bottom course shall be ~~similarly~~ connected to its support and the top course shall be ~~similarly~~ connected to the roof- or floor-bearing member above with pins or other *approved* means. Internal pins shall be continuous or shall overlap through not less than one bale course.

AS105.6.4 Horizontal surfaces. Bale walls and other bale elements shall be provided with a water-resistant barrier at weather-exposed horizontal surfaces. The water-resistant barrier shall be of a material and installation that will prevent water from entering the wall system. Horizontal surfaces shall include exterior window sills, sills at exterior niches and buttresses. ~~The finish material at such~~ Horizontal surfaces shall be sloped not less than 1 unit vertical in 12 units horizontal (8-percent slope) and shall drain away from bale walls and elements. Where the water-resistant barrier is below the finish material, it shall be sloped not less than 1 unit vertical in 12 units horizontal (8-percent slope) and shall drain to the outside surface of the bales wall's vertical finish.

AS105.6.8 Separation of wood and plaster. Where wood framing or wood sheathing occurs ~~on~~ at the exterior face of strawbale walls, such wood surfaces shall be separated from exterior plaster with two layers of Grade D paper, No. 15 asphalt felt or other *approved* material in accordance with Section R703.6.3.

Exceptions:

1. Where the wood is preservative treated or *naturally durable* and is not greater than $1\frac{1}{2}$ inches (38 mm) in width.
2. Clay plaster shall not be required to be separated from untreated wood that is not greater than $1\frac{1}{2}$ inches (38 mm) in width.

AS105.8 Voids and stuffing Voids between bales and between bales and framing members shall not exceed 4 inches (102 mm) in width, and such voids shall be tightly stuffed with *flakes*, loose straw, or *straw-clay* before application of finish.

~~**AS106.5 Voids and stuffing.** Voids between bales in strawbale *structural walls* shall not exceed 4 inches (102 mm) in width, and such voids shall be stuffed with flakes of straw or straw-clay, before application of finish.~~

AS106.11 Transfer of loads to and from plaster skins. Where plastered strawbale walls are used to support superimposed vertical loads, such loads shall be transferred to the plaster *skins* by continuous direct bearing or by an *approved* engineered design. Where plastered strawbale walls are used to resist in-plane lateral loads, such loads shall be transferred to the reinforcing mesh from the structural member or assembly above and to the sill plate in accordance with Table ~~AS106.13(3)~~ AS106.13(1).

AS106.12 Load-bearing walls. Plastered strawbale walls shall be permitted to be used as load-bearing walls in one-story buildings to support vertical loads imposed in accordance with Section R301, in accordance with and not more than the allowable bearing capacities ~~indicated~~ in Table AS106.12.

AS106.13 Braced wall panels. *No change to text.*

AS106.13.1 Bale wall thickness. The thickness of the ~~stacked bale strawbale~~ braced wall panels without ~~its~~ their plaster shall be not less than 15 inches (381 mm).

TABLE AS106.13 (2)
BRACING REQUIREMENTS FOR STRAWBALE BRACED WALL PANELS BASED ON WIND SPEED

<ul style="list-style-type: none"> EXPOSURE CATEGORY B^d • 25-FOOT MEAN ROOF HEIGHT • 10-FOOT EAVE-TO-RIDGE HEIGHT^d • 10-FOOT WALL HEIGHT^d • 2 BRACED WALL LINES^d 			MINIMUM TOTAL LENGTH (FEET) OF STRAWBALE BRACED WALL PANELS REQUIRED ALONG EACH BRACED WALL LINE ^{a, b, c, d}		
Basic <u>Ultimate</u> design wind speed (mph)	Story location	Braced wall line spacing (feet)	Strawbale braced wall panel ^e A2, A3	Strawbale braced wall panel ^e C1, C2, D1	Strawbale braced wall panel ^e B, D2, E1, E2
≤ 85 <u>110</u>	One-story building	10	6.4	3.8	3.0
		20	8.5	5.1	4.0
		30	10.2	6.1	4.8
		40	13.3	6.9	5.5
		50	16.3	7.7	6.1
		60	19.4	8.3	6.6
≤ 90 <u>115</u>	One-story building	10	6.4	3.8	3.0
		20	9.0 <u>8.5</u>	5.4 <u>5.1</u>	4.3 <u>4.0</u>
		30	11.2	6.4	5.1
		40	15.3 <u>14.3</u>	7.4 <u>7.2</u>	5.9 <u>5.7</u>
		50	18.4	8.1	6.5
		60	21.4	8.8	7.0
≤ <u>120</u>	One-story building	<u>10</u>	<u>7.1</u>	<u>4.3</u>	<u>3.4</u>
		<u>20</u>	<u>9.0</u>	<u>5.4</u>	<u>4.3</u>
		<u>30</u>	<u>12.2</u>	<u>6.6</u>	<u>5.3</u>
		<u>40</u>	<u>16.3</u>	<u>7.7</u>	<u>6.1</u>
		<u>50</u>	<u>19.4</u>	<u>8.3</u>	<u>6.6</u>
		<u>60</u>	<u>23.5</u>	<u>9.2</u>	<u>7.3</u>
≤ 100 <u>130</u>	One-story building	10	7.1	4.3	3.4
		20	10.2	6.1	4.8
		30	14.3	7.2	5.7
		40	18.4	8.1	6.5
		50	22.4	9.0	7.1
		60	26.5	9.8	7.8
≤ 110 <u>140</u>	One-story building	10	7.8	4.7	3.7
		20	12.2 <u>11.2</u>	6.6 <u>6.4</u>	5.35 <u>5.1</u>
		30	17.3 <u>16.3</u>	7.9 <u>7.7</u>	6.36 <u>6.1</u>
		40	22.4 <u>21.4</u>	9.08 <u>8.8</u>	7.17 <u>7.0</u>
		50	26.5	9.8	7.8
		60	31.6 <u>30.6</u>	11.4 <u>11.0</u>	8.5 <u>8.3</u>

For SI: 1 inch = 25.4 mm, 1 foot = 305 mm, 1 mile per hour = 0.447 m/s.

- Linear interpolation shall be permitted.
- All *braced wall panels* shall be without openings and shall have an aspect ratio (H:L) ≤ 2:1.
- Tabulated minimum total lengths are for *braced wall lines* using single braced wall panels with an aspect ratio (H:L) ≤ 2:1, or using multiple *braced wall panels* with *aspect ratios* (H:L) ≤ 1:1. For *braced wall lines* using two or more *braced wall panels* with an aspect ratio (H:L) > 1:1, the minimum total length shall be multiplied by the largest *aspect ratio* (H:L) of braced wall panels in that line.
- Subject to applicable wind adjustment factors associated with "All methods" in Table R602.10.3(2)
- Strawbale braced panel types indicated shall comply with Sections AS106.13.1 through AS106.13.3 and with Table AS106.13(1).

TABLE AS106.13 (3)
BRACING REQUIREMENTS FOR STRAWBALE BRACED WALL PANELS BASED ON SEISMIC DESIGN CATEGORY

• SOIL CLASS D ^{ft} • WALL HEIGHT = 10 FEET ^d • 15 PSF ROOF-CEILING DEAD LOAD ^d • BRACED WALL LINE SPACING ≤ 25 FEET ^d			MINIMUM TOTAL LENGTH (FEET) OF STRAWBALE BRACED WALL PANELS REQUIRED ALONG EACH BRACED WALL LINE ^{a, b, c, d}	
Seismic Design Category	Story location	Braced wall line length (feet)	Strawbale Braced Wall Panele A2, C1, C2, D1	Strawbale Braced Wall Panele B, D2, E1, E2
C	One-story building	10	5.7	4.6
		20	8.0	6.5
		30	9.8	7.9
		40	12.9	9.1
		50	16.1	10.4
D ₀	One-story building	10	6.0	4.8
		20	8.5	6.8
		30	10.9	8.4
		40	14.5	9.7
		50	18.1	11.7
D ₁	One-story building	10	6.3	5.1
		20	9.0	7.2
		30	12.1	8.8
		40	16.1	10.4
		50	20.1	13.0
D ₂	One-story building	10	7.1	5.7
		20	10.1	8.1
		30	15.1	9.9
		40	20.1	13.0
		50	25.1	16.3

For SI: 1 inch = 25.4 mm, 1 foot = 305 mm, 1 pound per square foot = 0.0479 kPa.

a. Linear interpolation shall be permitted.

b. *Braced wall panels* shall be without openings and shall have an *aspect ratio* (H:L) ≤ 2:1.

c. Tabulated minimum total lengths are for *braced wall lines* using single *braced wall panels* with an *aspect ratio* (H:L) ≤ 2:1, or using multiple *braced wall panels* with *aspect ratios* (H:L) ≤ 1:1. For *braced wall lines* using two or more *braced wall panels* with an *aspect ratio* (H:L) > 1:1, the minimum total length shall be multiplied by the largest *aspect ratio* (H:L) of *braced wall panels* in that line.

d. Subject to applicable seismic adjustment factors associated with "All methods" in Table R602.10.3(4), except "Wall dead load."

e. Strawbale *braced wall panel* types indicated shall comply with Sections AS106.13.1 through AS106.13.3 and Table AS106.13(1).

f. Wall bracing lengths are based on a soil site class "D". Interpolation of bracing lengths between Sds values associated with the seismic design categories is allowable where a site-specific Sds value is determined in accordance with Section 1613.3 of the International Building Code.

Reason: The proposed changes in this proposal fall into one of the following three categories, and are needed to:

1. Simplify or clarify ambiguous language.
2. Correct typographical errors, errata, and changes to referenced section numbers in the IRC that changed from the 2012 to the 2015 IRC, but were not identified in Appendix S in the process of publishing the 2015 IRC.
3. Change "basic wind speed" to "ultimate design wind speed" terminology and wind speeds in Tables AS105.4 and AS106.13(2), and update associated braced wall panel lengths in Table AS106.13(2).

Example changes in category 1 include adding "predominantly" to the definition of "Laid Flat", and removing "similarly" in Section AS105.4.2

Example changes in category 2, include removing the word "the" in Section AS101.1, correcting the footnote in column 1 of Table AS105.4 from "c" to "d", and replacing R703.6.4 with R703.7.4 in Section AS104.4.8. Another change in this category is the inclusion of strawbale braced wall panel type 'B' in Table AS106.13(2), which was inadvertently left out of the proposal approved by ICC in 2013. Wall type 'B' should have been included with wall types D₁, E₁, and E₂ in the last column of that table. The changes in category 3 are necessary because of the change in use from "basic wind speed" to "ultimate design wind speed" from the 2012 IRC to the 2015 IRC. This proposal updates Tables AS105.4 and AS106.13(2) to use "ultimate design wind speed" to make them consistent with the rest of the IRC. Table R301.2.3.1 Wind Speed Conversions was used in converting "basic wind speeds" to "ultimate design wind speeds."

The revised values for "minimum total length of straw bale braced wall panel" in Table AS106.13(2) were determined using the same procedure as in the original proposal approved by ICC in 2013. A new row is included in Table AS106.13(2) that correlates with the added row in Table 602.10.3(1) in the 2015 IRC, with an ultimate design wind speed of 120 mph.

The basis for the braced wall panel lengths in Table AS106.13(2) is in a document posted on the following webpage: <http://ecobuildnetwork.org/projects/straw-bale-code-supporting-documents>

In Section AS105.2, the words "except that greater heights shall be allowed with an *approved* engineered design" are added to Item 2 to be consistent with the existing language in related item 1.

Existing Section AS106.3 Voids and stuffing is moved from AS106 Structural to AS105 General to become Section AS105.8 because stuffing of voids is important not only for structural performance, but to ensure proper thermal performance and fireblocking for all strawbale walls. The content of the relocated section is the same, but with the important condition of voids between bales and framing members added.

Footnote 'f' is added to Table AS106.13(3) to be consistent with footnote 'b' in the correlating braced wall panel table in the IRC, Table R602.10.3(3).

Bibliography: <http://ecobuildnetwork.org/projects/straw-bale-code-supporting-documents>

Cost Impact: Will not increase the cost of construction

The proposed changes in this proposal address matters of ambiguous language and corrections of errata. Therefore they have no cost impact.

Report of Committee Action Hearings
--

Committee Action:

Approved as Submitted

Committee Reason: This proposal clarifies and improves the code, corrects errors and updates the wind speed terminology.

Assembly Action:

None

Final Action Results

RB366-16

AS

[←BACK](#)

Code Change No: RB367-16

Original Proposal

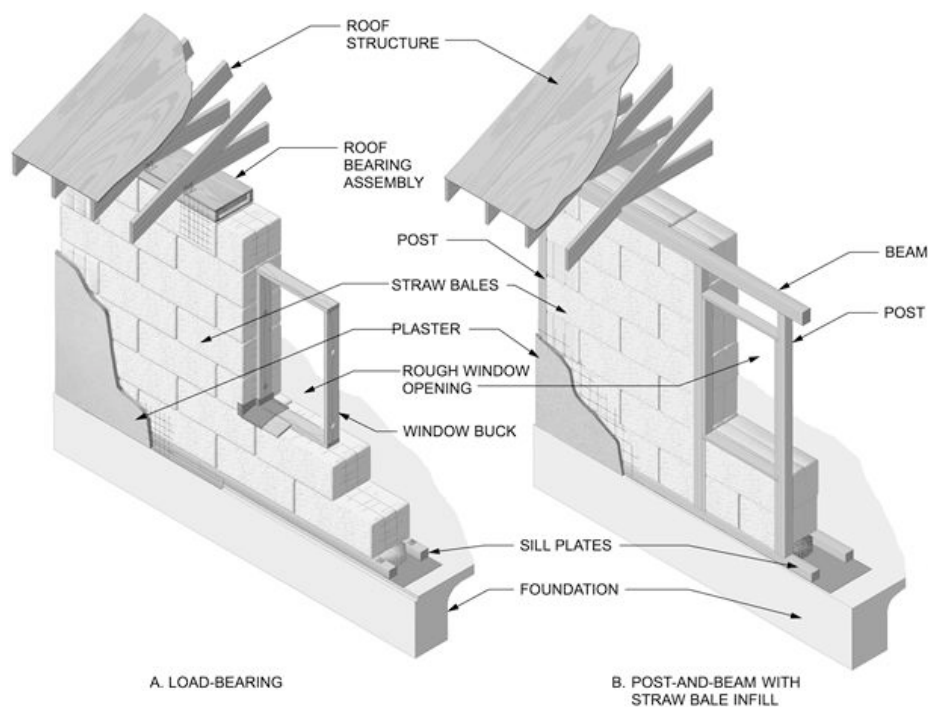
Section: AS101.2 (New), AS102.1, AS103.2, AS103.2 (New), AS105.1, AS105.1(1) (New), AS105.1(2) (New), AS105.1(3) (New), AS105.1(4) (New), AS105.3, AS106.10, AS106.11, AS106.12.3 (New), AS106.12.3.1 (New), AS106.15 (New), AS106.3

Proponent: Martin Hammer, representing Martin Hammer, Architect (mfhammer@pacbell.net); David Eisenberg, representing Development Center for Appropriate Technology

Revise as follows:

AS101.2 Strawbale wall systems. Strawbale wall systems include those shown in Figure AS101.2 and *approved variations*.

**FIGURE AS101.2
TYPICAL STRAWBALE WALL SYSTEMS**



NOTE: SEE FIGURES AS105.1(1) THROUGH AS105.1(4) FOR DETAILED VIEWS AND SECTION REFERENCES. OTHER STRAWBALE WALL SYSTEMS OR VARIATIONS ARE PERMITTED AS APPROVED.

AS102.1 Definitions. The following words and terms shall, for the purposes of this appendix, have the meanings shown herein. Refer to Chapter 2 of the *International Residential Code* for general definitions.

BALE. Equivalent to straw bale.

CLAY. Inorganic soil with particle sizes less than 0.00008 inch (0.002 mm) having the characteristics of high to very high dry strength and medium to high plasticity.

CLAY SLIP. A suspension of clay particles in water.

FINISH. Completed compilation of materials on the interior or exterior faces of stacked *bales*.

FLAKE. An intact section of compressed *straw* removed from an untied *bale*.

LAI D FLAT. The orientation of a bale with its largest faces horizontal, its longest dimension parallel with the wall plane, its *ties* concealed in the unfinished wall and its *straw* lengths oriented across the thickness of the wall. See Figure AS102.1.

LOAD-BEARING WALL. A strawbale wall that supports more than 100 pounds per linear foot (1459 N/m) of vertical load in addition its own weight.

MESH. An openwork fabric of linked strands of metal, plastic, or natural or synthetic fiber, embedded in plaster.

NONSTRUCTURAL WALL. Walls other than load-bearing walls or shear walls.

ON-EDGE. The orientation of a *bale* with its largest faces vertical, its longest dimension parallel with the wall plane, its *ties* on the face of the wall and its *straw* lengths oriented vertically. See Figure AS102.1.

ON-END. The orientation of a *bale* with its longest dimension vertical. For use in nonstructural strawbale walls only. See Figure AS102.1.

PIN. A vertical metal rod, wood dowel or bamboo, driven into the center of stacked bales, or placed on opposite surfaces of stacked bales and through-tied.

PLASTER. Gypsum or cement plaster, as defined in Sections R702 and AS104, or clay plaster, soil-cement plaster, lime plaster or cement-lime plaster as defined in Section AS104.

PRECOMPRESSION. Vertical compression of stacked bales before the application of finish.

REINFORCED PLASTER. A plaster containing mesh reinforcement.

RUNNING BOND. The placement of *straw bales* such that the head joints in successive courses are offset not less than one-quarter the bale length.

SHEAR WALL. A strawbale wall designed and constructed to resist lateral seismic and wind forces parallel to the plane of the wall in accordance with Section AS106.13.

SKIN. The compilation of plaster and reinforcing, if any, applied to the surface of stacked bales.

STRUCTURAL WALL. A wall that meets the definition for a load-bearing wall or shear wall.

STACK BOND. The placement of straw bales such that head joints in successive courses are vertically aligned.

STRAW. The dry stems of cereal grains after the seed heads have been removed.

STRAW BALE. A rectangular compressed block of straw, bound by ties.

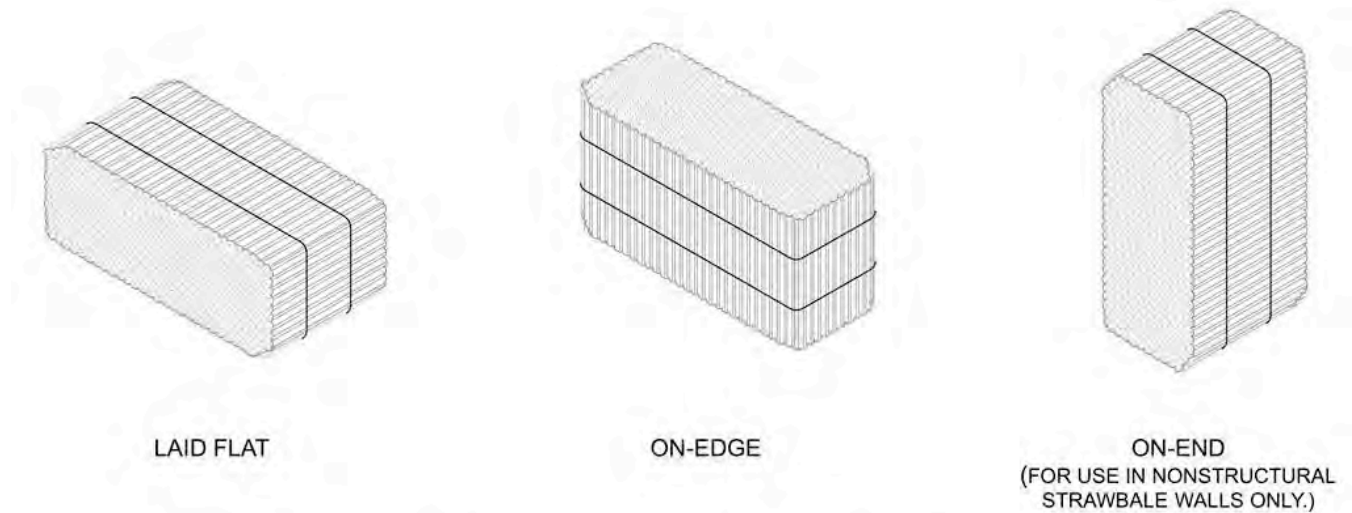
STRAWBALE. The adjective form of straw bale.

STRAW-CLAY. Loose straw mixed and coated with clay slip.

TIE. A synthetic fiber, natural fiber or metal wire used to confine a straw bale.

TRUTH WINDOW. An area of a strawbale wall left without its finish, to allow view of the straw otherwise concealed by its finish.

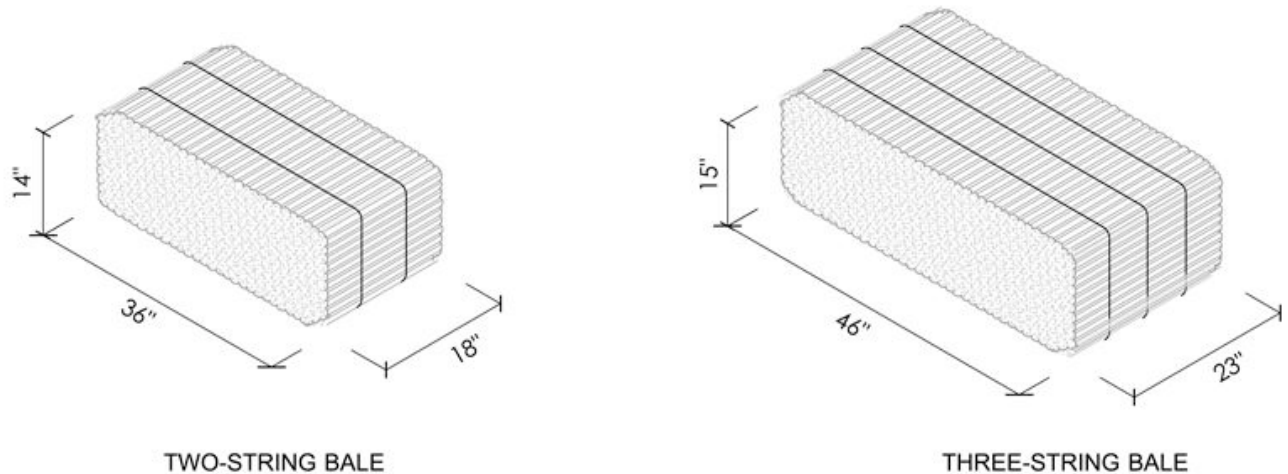
FIGURE AS101.2
BALE ORIENTATIONS



NOTE: ILLUSTRATIONS ALSO SHOW THE PREDOMINANT DIRECTION OF THE LENGTHS OF STRAW IN A TYPICAL STRAW BALE. HOWEVER, SOME RANDOMNESS OF DIRECTION IS NORMAL.

AS103.2 Size. Bales shall have a height and thickness of not less than 12 inches (305 mm), except as otherwise permitted or required in this appendix. Bales used within a continuous wall shall be of consistent height and thickness to ensure even distribution of loads within the wall system. See Figure AS103.2 for approximate dimensions of common straw bales.

FIGURE AS103.2
APPROXIMATE DIMENSIONS OF COMMON STRAW BALES



For SI: 1 inch = 25.4 mm

AS105.1 General. Strawbale walls shall be designed and constructed in accordance with this section and with Figures AS105.1(1) through AS105.1(4) or an *approved* alternative design. Strawbale structural walls shall be in accordance with the additional requirements of Section AS106.

AS105.3 Sill plates. Sill plates shall be installed in accordance with Figure AS105.3(1) or AS105.3(2). Sill plates shall support and be flush with each face of the straw bales above and shall be of naturally durable or preservative-treated wood where required by this code. Sill plates shall be not less than nominal 2 inches by 4 inches (51 mm by 102 mm) with anchoring complying with Section R403.1.6 and the additional requirements of Tables AS105.4 and AS106.6(1), where applicable.

AS106.3 Foundations. Foundations for plastered strawbale walls shall be in accordance with Chapter 4, Figure AR105.1(1) or Figure AR105.1(2).

AS106.10 Support of plaster skins. Plaster *skins* on strawbale structural walls shall be continuously supported along their bottom edge. Acceptable supports include: a concrete or masonry stem wall, a concrete slab-on-grade, a wood-framed floor blocked in accordance with Figure AS105.1(2) and an *approved* engineered design, or a steel angle anchored with an *approved* engineered design. A weep screed as described in Section R703.7.2.1 is not an acceptable support.

AS106.11 Transfer of loads to and from plaster skins. Where plastered strawbale walls are used to support superimposed vertical loads, such loads shall be transferred to the plaster *skins* by continuous direct bearing in accordance with Figure AS105.1(3) or by an *approved* engineered design. Where plastered strawbale walls are used to resist in-plane lateral loads, such loads shall be transferred to the reinforcing mesh from the structural member or assembly above in accordance with Figure AS105.1(3) or AS105.1(4) and to the sill plate in accordance with Figure AS105.1(1) or AS105.1(2) and with Table AS106.13(3) AS106.13(1).

AS106.12.3 Roof bearing assembly. Roof bearing assemblies shall be of nominal 2-inch by 6-inch (51 mm by 152 mm) lumber with 15/32-inch (12 mm) plywood or OSB panels fastened with 8d nails at 6 inches (152 mm) o.c. in accordance with Figure AS105.1(3) and Items 1 through 4, or be of an *approved* engineered design.

1. Discontinuous lumber shall be spliced with a metal strap with not less than a 500 pound (2224 N) allowable wind or seismic load tension capacity. Where the wall line includes a braced wall panel

- the strap shall have not less than a 2000 pound (8896 N) capacity.
- 2. Panel joints shall be blocked.
- 3. Roof and ceiling framing shall be attached to the roof bearing assembly in accordance with Table R602.3(1) Items 2 and 6.
- 4. Where the roof bearing assembly spans wall openings it shall comply with Section AS106.12.3.1

AS106.12.3.1 Roof bearing assembly spanning openings. Roof bearing assemblies that span openings in strawbale walls shall comply with the following at each opening:

- 1. Lumber on each side of the assembly shall be of the dimensions and quantity required to span each opening in accordance with Table R602.7(1).
- 2. The required lumber in the assembly shall be supported at each side of the opening by the number of jack studs required by Table R602.7(1), or shall extend beyond the opening on both sides a distance D, using the following formula:

$$D = S \times R/2 / (1-R)$$

where:

D = minimum distance (in feet) for required spanning lumber to extend beyond the opening

S = span in feet

$R = B_L / B_C$

B_L = design load on the wall (in pounds per lineal foot) in accordance with Sections R301.4 and R301.6

B_C = allowable bearing capacity of the wall in accordance with Table AS106.12

AS106.15 Post-and-beam with strawbale infill. Post-and-beam with strawbale infill systems shall be in accordance with Figure AS105.1(4) and Items 1 through 6, or be of an *approved* engineered design.

- 1. Beams shall be of the dimensions and number of members in accordance with Table R602.7(1), where the space between posts equals the span in the table.
- 2. Beam ends shall bear over posts not less than 1 1/2 inches (38 mm) or be supported by a framing anchor in accordance with Table R602.7(1).
- 3. Discontinuous beam ends shall be spliced with a metal strap with not less than 1000 pound (4448 kg) wind or seismic load tension capacity. Where the wall line includes a braced wall panel the strap shall have a not less than a 4000 pound (17,793 kg) capacity.
- 4. Each post shall equal $NJ + 1$ in accordance with Table R602.7(1), where the space between posts equals the span in the table.
- 5. Posts shall be connected to the beam with an *approved* means.
- 6. Roof and ceiling framing shall be attached to the beam in accordance with Table R602.3(1) Items 2 and 6.

FIGURE AS105.1(1)
TYPICAL BASE OF PLASTERED STRAWBALE WALL ON CONCRETE SLAB AND FOOTING

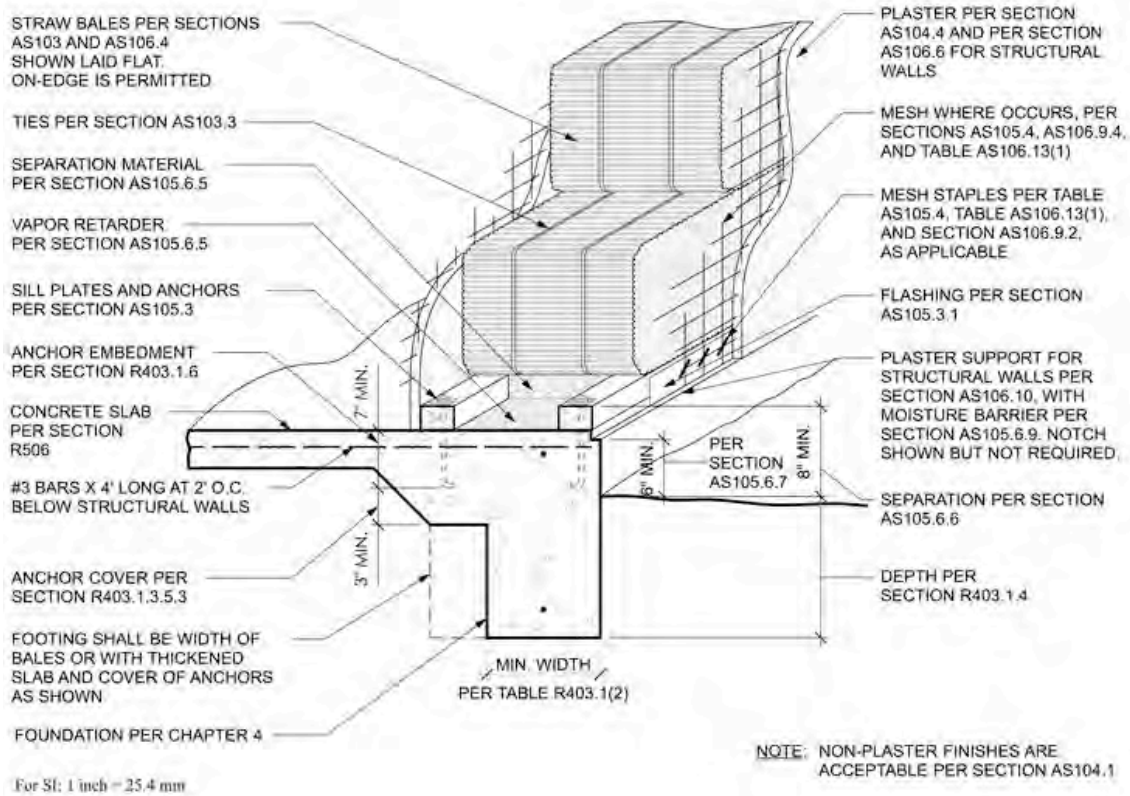
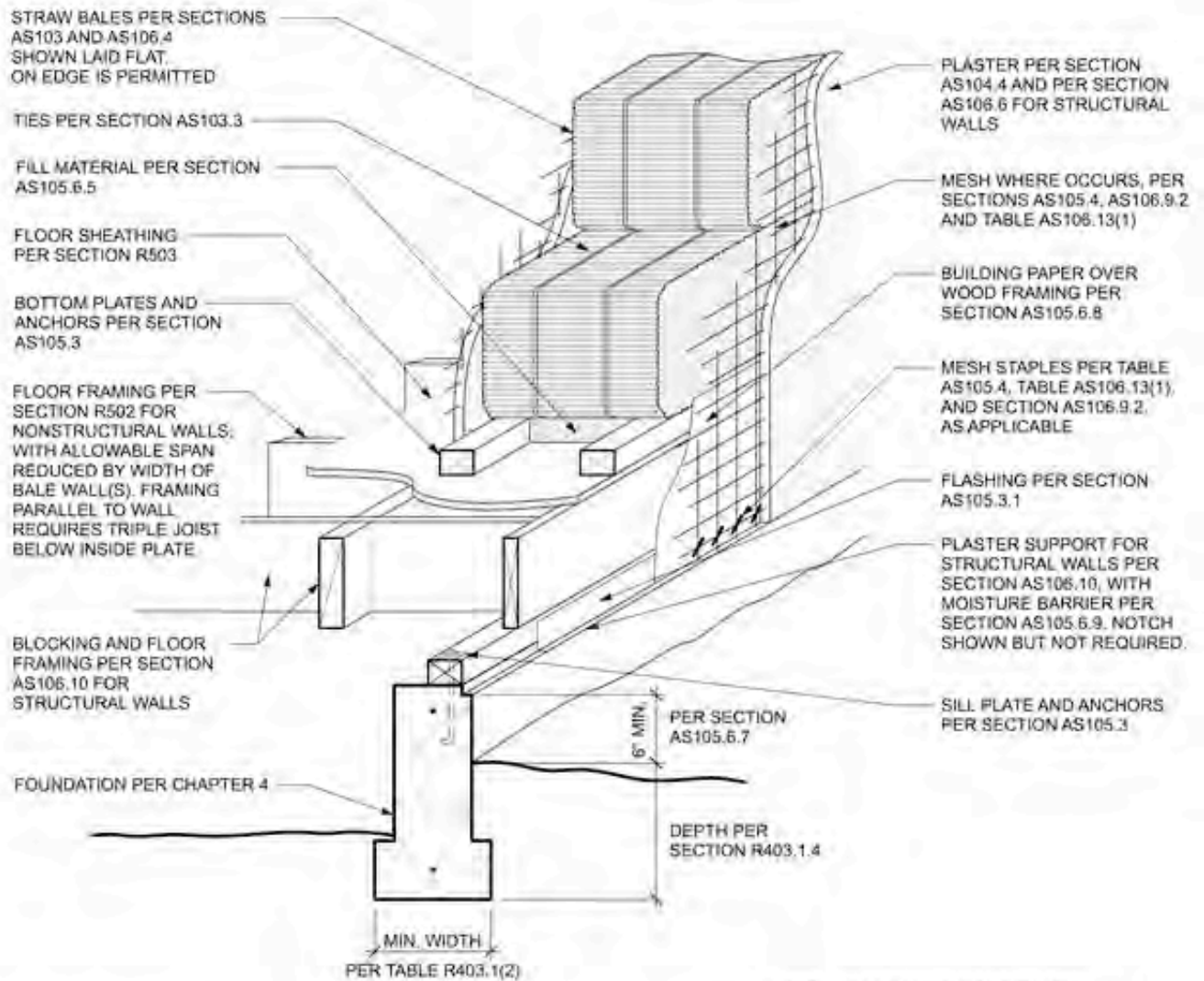


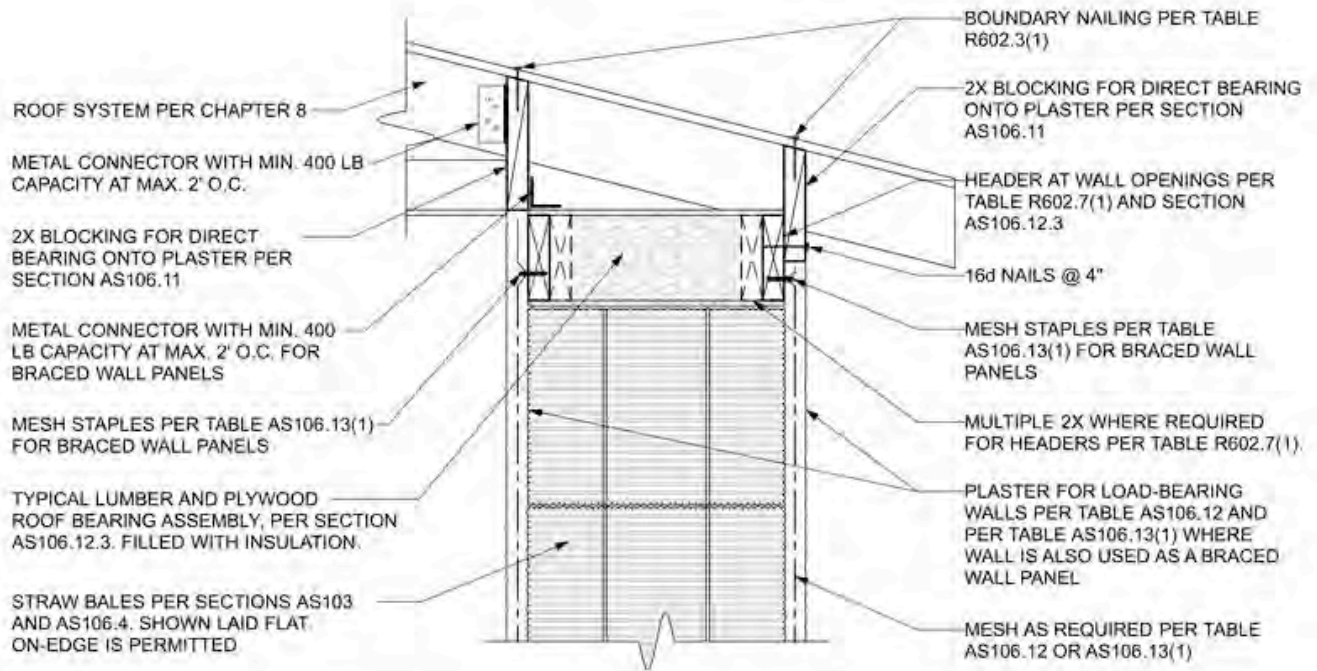
FIGURE AS105.1(2)
TYPICAL BASE OF PLASTERED STRAWBALE WALL OVER RAISED FLOOR



For SI: 1 inch = 25.4 mm

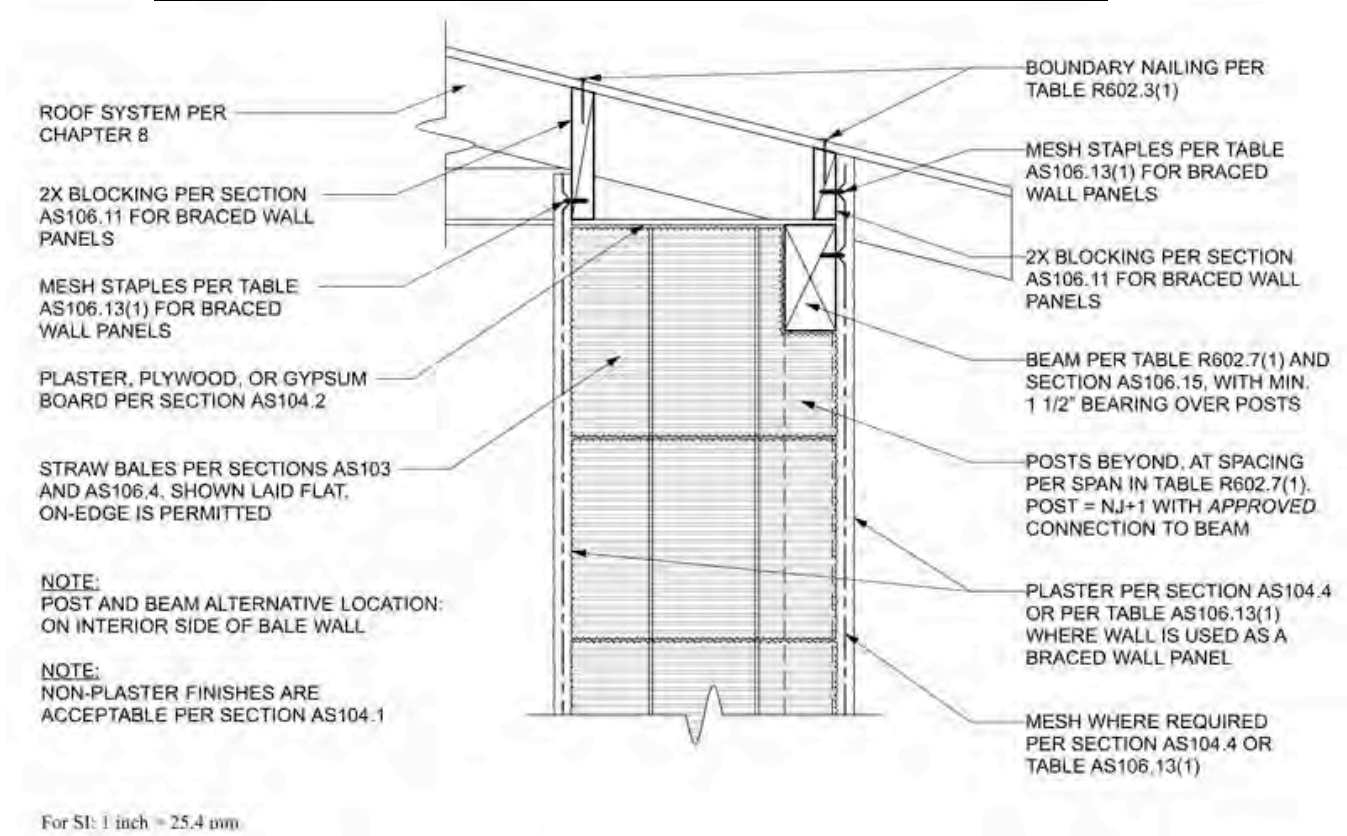
NOTE: NON-PLASTER FINISHES ARE ACCEPTABLE PER SECTION AS104.1

FIGURE AS105.1(3)
TYPICAL TOP OF LOAD-BEARING STRAWBALE WALL



For SI: 1 inch = 25.4 mm

FIGURE AS105.1(4)
TYPICAL TOP OF POST-AND-BEAM WALL WITH PLASTERED STRAW BALE INFILL



Reason: This proposal brings seven Figures that illustrate strawbale wall systems and their components from the Commentary into Appendix S. Many design professionals, builders, and building officials are unfamiliar with strawbale construction, and these Figures provide clear visualization of the primary components of the most common systems of strawbale construction. The Figures reference appendix sections and their associated requirements. The callout text of the Commentary Figures was modified in some cases to make the Figures suitable for inclusion in the Appendix.

Sections AS106.12.3 Roof bearing assembly, and AS106.15 Post-and-beam with strawbale infill, are added to bring requirements from the figures into the body of the appendix. These requirements are complete, whereas the requirements in the figures in the commentary of the 2015 IRC are not. Engineering analysis justifying these requirements are posted at: <http://ecobuildnetwork.org/projects/straw-bale-code-supporting-documents>

Ten registered design professionals and builders with extensive experience in strawbale construction in different climates and regions of the United States had input in the creation of these Figures. At least half of these practitioners have experience with strawbale buildings in high seismic zones.

Bibliography: <http://ecobuildnetwork.org/projects/straw-bale-code-supporting-documents>

Cost Impact: Will not increase the cost of construction

The proposed Figures depict components of strawbale wall systems and illustrate requirements that already exist in Appendix S. Therefore there is no cost impact.

**Report of Committee Action
Hearings**

Committee Action:

Approved as Submitted

Committee Reason: The figures add clarity and help users.

Assembly Action:

None

Final Action Results

RB367-16

AS

[←BACK](#)

Code Change No: **RB368-16**

Original Proposal

Section: AS102.1, AS104.2, AS104.4.3.1, AS104.4.3.2, AS104.4.4.1, AS105.3.1 (New), AS105.4, AS105.6, AS105.6.9 (New), AS106.1, AS106.12.3 (New), AS106.12.3.1 (New), AS106.12.5 (New), AS106.2 (New), AS108.1, AS108.2 (New), AS109

Proponent: Martin Hammer, representing Martin Hammer, Architect (mfhammer@pacbell.net); David Eisenberg, representing Development Center for Appropriate Technology

Revise as follows:

AS102.1 Definitions. The following words and terms shall, for the purposes of this appendix, have the meanings shown herein. Refer to Chapter 2 of the *International Residential Code* for general definitions.

BALE. Equivalent to straw bale.

CLAY. Inorganic soil with particle sizes less than 0.00008 inch (0.002 mm) having the characteristics of high to very high dry strength and medium to high plasticity.

CLAY SLIP. A suspension of clay ~~particles~~ subsoil in water.

CLAY SUBSOIL. Subsoil sourced directly from the earth or refined, containing clay and free of organic matter.

FINISH. Completed compilation of materials on the interior or exterior faces of stacked *bales*.

FLAKE. An intact section of compressed *straw* removed from an untied *bale*.

LAI D FLAT. The orientation of a bale with its largest faces horizontal, its longest dimension parallel with the wall plane, its *ties* concealed in the unfinished wall and its *straw* lengths oriented across the thickness of the wall.

LOAD-BEARING WALL. A strawbale wall that supports more than 100 pounds per linear foot (1459 N/m) of vertical load in addition its own weight.

MESH. An openwork fabric of linked strands of metal, plastic, or natural or synthetic fiber, embedded in plaster.

NONSTRUCTURAL WALL. Walls other than load-bearing walls or shear walls.

ON-EDGE. The orientation of a *bale* with its largest faces vertical, its longest dimension parallel with the wall plane, its *ties* on the face of the wall and its *straw* lengths oriented vertically.

ON-END. The orientation of a *bale* with its longest dimension vertical. For use in nonstructural strawbale walls only.

PIN. A vertical metal rod, wood dowel or bamboo, driven into the center of stacked bales, or placed on opposite surfaces of stacked bales and through-tied.

PLASTER. Gypsum or cement plaster, as defined in Sections R702 and AS104, or clay plaster, soil-cement plaster, lime plaster or cement-lime plaster as defined in Section AS104.

PRECOMPRESSION. Vertical compression of stacked bales before the application of finish.

REINFORCED PLASTER. A plaster containing mesh reinforcement.

RUNNING BOND. The placement of *straw bales* such that the head joints in successive courses are offset not less than one-quarter the bale length.

SHEAR WALL. A strawbale wall designed and constructed to resist lateral seismic and wind forces parallel to the plane of the wall in accordance with Section AS106.13.

SKIN. The compilation of plaster and reinforcing, if any, applied to the surface of stacked bales.

STRUCTURAL WALL. A wall that meets the definition for a load-bearing wall or shear wall.

STACK BOND. The placement of straw bales such that head joints in successive courses are vertically aligned.

STRAW. The dry stems of cereal grains after the seed heads have been removed.

STRAW BALE. A rectangular compressed block of straw, bound by ties.

STRAWBALE. The adjective form of straw bale.

STRAW-CLAY. Loose straw mixed and coated with clay slip.

TIE. A synthetic fiber, natural fiber or metal wire used to confine a straw bale.

TRUTH WINDOW. An area of a strawbale wall left without its finish, to allow view of the straw otherwise concealed by its finish.

AS104.2 Purpose, and where required. Strawbale walls shall be finished so as to provide mechanical protection, fire resistance and protection from weather and to restrict the passage of air through the bales, in accordance with this appendix and this code. Vertical strawbale wall surfaces shall receive a coat of plaster not less than $\frac{3}{8}$ inch (10 mm) thick, or greater where required elsewhere in this appendix, or shall fit tightly against a solid wall panel or dense-packed cellulose insulation with a density of not less than 3.5 pounds per cubic foot (56 kg/cubic meter) blown into an adjacent framed wall. The tops of strawbale walls shall receive a coat of plaster not less than $\frac{3}{8}$ inch (10 mm) thick where straw would otherwise be exposed.

Exception: Truth windows shall be permitted where a fire-resistance rating is not required. Weather-exposed truth windows shall be fitted with a weather-tight cover. Interior truth windows in Climate Zones 5, 6, 7, 8 and Marine 4 shall be fitted with an air-tight cover.

AS104.4.3.1 General. Clay plaster shall be any plaster having a clay or ~~clay soil~~ clay subsoil binder. Such plaster shall contain sufficient clay to fully bind the ~~plaster,~~ sand or other inert granular material, and shall be permitted to contain reinforcing fibers. Acceptable reinforcing fibers include chopped straw, sisal and animal hair.

AS104.4.3.2 ~~Lath and mesh~~ Clay subsoil requirements. ~~Clay plaster shall not be required to contain reinforcing lath or mesh except as required in Tables AS105.4 and AS106.13(1). Where provided, mesh~~ The suitability of clay subsoil shall be natural fiber, corrosion-resistant metal, nylon, high-density polypropylene determined in accordance with the Figure 2 Ribbon Test or other approved material the Figure 3 Ball Test in the appendix of ASTM E2392/E2392M.

AS104.4.4.1 General. Soil-cement plaster shall be composed of soil (free of organic matter) clay subsoil, sand and not less than 10 percent and not more than 20 percent Portland cement by volume, and shall be permitted to contain reinforcing fibers.

AS105.3.1 Exterior sill plate flashing. Exterior sill plates shall receive flashing across plate to slab or foundation joints.

TABLE AS105.4
OUT-OF-PLANE RESISTANCE METHODS AND UNRESTRAINED WALL DIMENSIONS-DIMENSION LIMITS

METHOD OF OUT-OF-PLANE RESISTANCE ^a	FOR ULTIMATE DESIGN WIND DESIGN SPEEDS (mph)	FOR SEISMIC DESIGN CATEGORIES	UNRESTRAINED WALL DIMENSIONS, H ^b		MESH STAPLE SPACING AT BOUNDARY RESTRAINTS
			Absolute limit in feet	Limit based on bale thickness T ^c in feet (mm)	
Nonplaster finish or unreinforced plaster	≤ 130	A, B, C, D ₀	H ≤ 8	H ≤ 5T	None required
Pins per Section AS105.4.2	≤ 130	A, B, C, D ₀	H ≤ 12	H ≤ 8T	None required
Pins per Section AS105.4.2	≤ 140	A, B, C, D ₀ , D ₁ , D ₂	H ≤ 10	H ≤ 7T	None required
Reinforced ^{ed} clay plaster	≤ 140	A, B, C, D ₀ , D ₁ , D ₂	H ≤ 10	$H \leq 8T^{0.5}$ ($H \leq 140T^{0.5}$)	≤ 6 inches
Reinforced ^{ed} clay plaster	≤ 140	A, B, C, D ₀ , D ₁ , D ₂	10 H ≤ 12	$H \leq 8T^{0.5}$ ($H \leq 140T^{0.5}$)	≤ 4 inches ^e
Reinforced ^{ed} cement, cement-lime, lime or soil-cement plaster	≤ 140	A, B, C, D ₀ , D ₁ , D ₂	H ≤ 10	$H \leq 9T^{0.5}$ ($H \leq 157T^{0.5}$)	≤ 6 inches
Reinforced ^{ed} cement, cement-lime, lime or soil-cement plaster	≤ 155	A, B, C, D ₀ , D ₁ , D ₂	H ≤ 12	$H \leq 9T^{0.5}$ ($H \leq 157T^{0.5}$)	≤ 4 inches ^e
2x6 load-bearing studs ^f at max. 6' o.c.	≤ 140	A, B, C, D ₀ , D ₁ , D ₂	H ^d ≤ 9	NA	None required
2x6 load-bearing studs ^f at max. 4' o.c.	≤ 140	A, B, C, D ₀ , D ₁ , D ₂	H ^d ≤ 10	NA	None required
2x6 load-bearing studs ^f at max. 2' o.c.	≤ 140	A, B, C, D ₀ , D ₁ , D ₂	H ^d ≤ 12	NA	None required
2x4 load-bearing studs ^f at max. 2' o.c.	≤ 140	A, B, C, D ₀ , D ₁ , D ₂	H ^d ≤ 10	NA	None required
2x6 nonload-bearing studs ^f at max. 6' o.c.	≤ 140	A, B, C, D ₀ , D ₁ , D ₂	H ^d ≤ 12	NA	None required

For SI: 1 inch = 25.4 mm, 1 foot = 304.8 mm.

a. Finishes applied to both sides of stacked bales. Where different finishes are used on opposite sides of a wall, the more restrictive requirements shall apply.

b. H = Stacked bale height in feet (mm) between sill plate and top plate or other approved horizontal restraint, or the horizontal distance in feet (mm) between approved vertical restraints. For load-bearing walls, H refers to vertical height only.

c. T = Bale thickness in feet (mm).

d. Plaster reinforcement shall be any mesh allowed in Table AS106.16 for the matching plaster type, and with staple spacing in accordance with this table. Mesh shall be installed in accordance with Section AS106.9.

e. Sill plate attachment shall be with 5/8-inch anchor bolts or approved equivalent at not more than 48 inches on center where staple spacing is required to be ≤ 4 inches

f. Bales shall be attached to the studs by an approved method. Horizontal framing and attachment at top and bottom of studs shall be in accordance with Section R602 or an approved alternative. Table R602.7(1) shall be used to determine the top framing member where load-bearing stud spacing exceeds 24-inches o.c.
g. H is vertical height only.

AS105.6 Moisture control. Strawbale walls shall be protected from moisture intrusion and damage in accordance with Sections AS105.6.1 through ~~AS105.6.8~~AS105.6.9.

AS105.6.9 Separation of exterior plaster and foundation. Exterior plaster shall be separated from the building foundation with a moisture barrier.

AS106.1 General. Plastered strawbale walls shall be permitted to be used as structural walls in ~~one-story buildings~~ in accordance with the prescriptive provisions of this section.

AS106.2 Building limitations and requirements for use of strawbale structural walls. Buildings using strawbale *structural* walls shall be subject to the following limitations and requirements:

1. Number of stories: Not more than one.
2. Building height: Not more than 25 feet (7620 mm).
3. Wall height: In accordance with Tables AS105.4, AS106.13(2) and AS106.13(3) as applicable, whichever is most restrictive.
4. Braced wall panel lengths: The greater of the values determined in accordance with Tables AS106.13(2) and AS106.13(3) for buildings using strawbale braced wall panels, or in accordance with Section AS105.2(4) for buildings with load-bearing strawbale walls that do not use strawbale braced wall panels.

AS106.12.3 Roof bearing assembly. Roof bearing assemblies shall be of nominal 2-inch by 6-inch (51 mm by 152 mm) lumber with 15/32-inch (12 mm) plywood or OSB panels fastened with 8d nails at 6 inches (152 mm) o.c. in accordance with Items 1 through 6, or be of an *approved* engineered design.

1. Assembly shall be a box assembly on the top course of bales, with the panels horizontal.
2. Assembly shall be the width of the strawbale wall and shall comply with Section AS106.11.
3. Discontinuous lumber shall be spliced with a metal strap with a minimum 500 pound (2224 N) allowable wind or seismic load tension capacity. Where the wall line includes a braced wall panel the strap shall have not less than a 2000 pound (8896 N) capacity.
4. Panel joints shall be blocked.
5. Roof and ceiling framing shall be attached to the roof bearing assembly in accordance with Table R602.3(1) Items 2 and 6.
6. Where the roof bearing assembly spans wall openings it shall comply with Section AS106.12.3.1.

AS106.12.3.1 Roof bearing assembly spanning openings. Roof bearing assemblies that span openings in strawbale walls shall comply with the following at each opening:

1. Lumber on each side of the assembly shall be of the dimensions and quantity required to span each opening in accordance with Table R602.7(1).
2. The required lumber in the assembly shall be supported at each side of the opening by the number of jack studs required by Table R602.7(1), or shall extend beyond the opening on both sides a distance D, using the following formula:

$$D = S \times R/2 / (1-R)$$

where:

D = minimum distance (in feet) for required spanning lumber to extend beyond the opening

S = span in feet

R = B_L / B_C

B_L = design load on the wall (in pounds per lineal foot) in accordance with Sections R301.4 and

R301.6

B_c = allowable bearing capacity of the wall in accordance with Table AS106.12

AS106.12.5 Post-and-beam with strawbale infill. Post-and-beam with strawbale infill systems shall be in accordance with Items 1 through 6, or an *approved* engineered design.

1. Beams shall be of the dimensions and number of members in accordance with Table R602.7(1), where the space between posts equals the span in the table.
2. Beam ends shall bear over posts not less than 1 1/2 inches (38 mm) or be supported by a framing anchor in accordance with Table R602.7(1).
3. Discontinuous beam ends shall be spliced with a metal strap with not less than 1000 pound (4448 kg) wind or seismic load tension capacity. Where the wall line includes a braced wall panel, the strap shall have not less than a 4000 pound (17,793 kg) capacity.
4. Each post shall equal $NJ + 1$ in accordance with Table R602.7(1), where the space between posts equals the span in the table.
5. Posts shall be connected to the beam by an *approved* means.
6. Roof and ceiling framing shall be attached to the beam in accordance with Table R602.3(1) Items 2 and 6.

AS108.1 R-value. The unit *R*-value of a strawbale wall with bales laid flat is ~~R-1.3~~ per R-1.55 for each inch of bale thickness. The unit *R*-value of a strawbale wall with bales on-edge is ~~R-2~~ per R-1.85 for each inch of bale thickness.

AS108.2 Compliance with Section R302.10.1 Straw bales meet the requirements for insulation materials in Section R302.10.1 for flame spread index and smoke-developed index as tested in accordance with ASTM E84.

SECTION AS109 REFERENCED STANDARDS

ASTM

C 5—10	Standard Specification for Quicklime for Structural Purposes	AS104.4.6.1
C 109/C 109M—12	Standard Test Method for Compressive Strength of Hydraulic Cement Mortars	AS106.6.1
C 141/C 141M—09	Standard Specification for Hydrated Hydraulic Lime for Structural Purposes	AS104.4.6.1
C 206—03	Standard Specification for Finishing Hydrated Lime	AS104.4.6.1
C 926—12a	Standard Specification for Application of Portland Cement Based Plaster	AS104.4.7, AS104.4.8
C 1707—11	Standard Specification for Pozzolanic Hydraulic Lime for Structural Purposes	AS104.4.6.1
<u>E2392/E2392M-10</u>	<u>Standard Guide for Design of Earthen Wall Building Systems</u>	<u>AS104.4.3.2</u>

EN

459—2010	Part 1: Building Lime. Definitions, Specifications and Conformity Criteria; Part 2: Test Methods	AS104.4.6.1
----------	---	-------------

Reason: The proposed code changes in this proposal create new or revised requirements relative to the appendix as first approved for the 2015 IRC. These changes are based on further experience and additional input from prominent straw bale construction design and building professionals in different regions of the United States. Reasons for proposed changes per section are as follows:

AS102.1 Definitions:

A definition for CLAY SUBSOIL is added and the term is then used in subsections of Section AS104.4.3 and in the definition of CLAY SLIP. This brings clarity to this often misunderstood material used in many strawbale wall systems.

A definition for ON-END is added because bales are increasingly and successfully being used in this orientation in nonstructural straw bale walls for insulation and a substrate for plaster.

AS104.2 Purpose, and where required:

New language allows the face of a bale wall to remain unplastered when tight against dense-packed cellulose insulation in an adjacent framed wall. This satisfies the relevant purposes of restricting air movement for thermal performance and the potential spread of fire. This has been practiced successfully in permitted, inspected strawbale buildings regionally. An industry magazine article is posted at: <http://ecobuildnetwork.org/projects/straw-bale-code-supporting-documents>

AS104.4.3.2 Lath and mesh:

The existing section title and content are sufficiently addressed in Section AS104.4.2 Lath and mesh for plaster, and therefore are removed. The important subject clay subsoil suitability is absent from the current appendix. Therefore a new section title, "Clay subsoil requirements", and two tests from ASTM 2392-10 that are commonly used by clay plaster practitioners to determine the suitability of clay subsoil, are proposed.

AS105.3.1 Exterior sill plate flashing:

This new section requires flashing across plate to slab or foundation joints to prevent water intrusion at this location. This important requirement is currently absent from Appendix S.

Table AS105.4:

Wood framing is added as a method of out-of-plane resistance with an approved means of attachment of the bales to the framing. This method has been successfully utilized regionally for over 10 years for strawbale walls adjacent to or integrated with wood frame walls. Structural calculations justifying the particulars of the variables in the table are posted at: <http://ecobuildnetwork.org/projects/straw-bale-code-supporting-documents>

AS105.6.9 Separation of exterior plaster and foundation:

This new section requires a moisture barrier between a strawbale wall's exterior plaster and the foundation to prevent the wicking of moisture into the exterior plaster and potentially to the bales at this location. This important requirement is currently absent from Appendix S.

AS106.1 General:

The limitation of one-story is removed from this section and relocated to Section AS106.2.

AS106.2 Building limitations and requirements for use of strawbale *structural* walls:

This new section gives building limitations and requirements in the same format as Section 105.2 for non-structural walls. It gives clarity and corrals existing information for structural walls in scattered locations. In Item 4 it also clarifies that braced wall panel lengths are to be the greater value of those shown in Tables AS106.13.3(1) and AS106.13.3(2).

AS106.12.3 Roof bearing assembly:

This new section prescribes a roof bearing assembly for load-bearing strawbale walls. Details of this common member of a load-bearing strawbale wall are currently absent from Appendix S. Engineering analysis justifying the requirements in this section are posted at: <http://ecobuildnetwork.org/projects/straw-bale-code-supporting-documents>

AS106.12.3.1 Roof bearing assembly spanning openings:

IRC Table R602.10(1) for girders and headers is used to determine the size of lumber elements in the roof bearing assembly where it spans a wall opening. A formula is given to determine the required distance for the header element to extend beyond the wall opening where jack studs are not used. Engineering analysis justifying the requirements in this section are posted at: <http://ecobuildnetwork.org/projects/straw-bale-code-supporting-documents>

AS106.15 Post-and-beam with strawbale infill:

This new section prescribes a post-and-beam system with strawbale infill. Details of this common system are currently absent from Appendix S. IRC Table R602.10(1) for girders and headers is used to determine the beam size and the posts depending on the span and loading conditions. Engineering analysis justifying the requirements in this section are posted at: <http://ecobuildnetwork.org/projects/straw-bale-code-supporting-documents>

AS108.1 R-value:

The proposed changes in unit R-values for bales laid flat and bales on-edge are based on new data from thermal resistance tests conducted in Denmark (2004) and the U.K. (2012) along with tests at the Oak Ridge National Laboratory (ORNL) in Tennessee (1998). The ORNL tests were conducted in accordance with the guarded hot box protocol of ASTM C236, and the Danish and U.K. tests in accordance with its ISO equivalent, ISO 8990.

The current values in Section AS108.1 were based on the ORNL test and analysis by the California Energy Commission (CEC), which conservatively established the R-value for bales laid flat at R1.3 per inch from the ORNL test value of R1.45. Taking all three tests into account, the R-value for bales laid flat is adjusted upward to R1.55 and is adjusted downward to R1.85 for bales on-edge. The predominant orientation of straw in common bales continues to explain why the unit R-value varies with bale orientation.

Analysis of the data was performed by energy consultant Nehemiah Stone who was part of the team that conducted the CEC analysis in 1998. The current analysis as well as the reports from the Danish Urban and Building Research Institute and University of Bath (U.K.) tests are posted at: <http://ecobuildnetwork.org/projects/straw-bale-code-supporting-documents>

AS108.2 Compliance with Section R302.10.1:

This new section states compliance with the requirements of Section R302.10.1 and is necessary because building officials and design and building professionals are generally unaware of or would be unable to find the ASTM E84 test conducted in 2000 that demonstrated that straw bales meet these requirements. The test report is posted at: <http://ecobuildnetwork.org/projects/straw-bale-code-supporting-documents>

Bibliography: <http://ecobuildnetwork.org/projects/straw-bale-code-supporting-documents>

Cost Impact: Will not increase the cost of construction

The proposed code changes in this proposal are minor relative to the overall system of strawbale construction and therefore will have no cost impact when using this method of construction.

Report of Committee Action Hearings
--

Committee Action:

Approved as Submitted

Committee Reason: This proposal makes improvements to straw bale as recommended by the industry. The committee would like to see the wind speed calculations tweaked and the proper standards referenced for blown in cellulose insulation in the public comment period as discussed in testimony.

Assembly Action:

None

Final Action Results

RB368-16

AS

[←BACK](#)

Code Change No: RB376-16

Original Proposal

Section: R703.8.4

Proponent: Charles Clark, Jr, representing Masonry Alliance for Codes and Standards (Brick Industry Association) (cclark@bia.org)

Revise as follows:

**TABLE R703.8.4
TIE ATTACHMENT AND AIRSPACE REQUIREMENTS**

BACKING AND TIE	MINIMUM TIE	MINIMUM TIE FASTENER ^a	AIRSPACE ^c	
Wood stud backing with corrugated sheet metal	22 U.S. gage (0.0299 in.) x ⁷ / ₈ in. wide	8d common nail ^b (2 ¹ / ₂ in. x 0.131 in.)	Nominal 1 in. between sheathing and veneer	
Wood stud backing with metal strand wire	W1.7 (No. 9 U.S. gage; 0.148 in.) with hook embedded in mortar joint	8d common nail ^b (2 ¹ / ₂ in. x 0.131 in.)	Minimum nominal 1 in. between sheathing and veneer	Maximum 4 ¹ / ₂ in. between backing and veneer
Cold-formed steel stud backing with adjustable metal strand wire	W1.7 (No. 9 U.S. gage; 0.148 in.) with hook embedded in mortar joint	No. 10 screw extending through the steel framing a minimum of three exposed threads	Minimum nominal 1 in. between sheathing and veneer	Maximum 4 ¹ / ₂ in. between backing and veneer

For SI: 1 inch = 25.4 mm.

a. In Seismic Design Category D₀, D₁ or D₂, the minimum tie fastener shall be an 8d ring-shank nail (2¹/₂ in. x 0.131 in.) or a No. 10 screw extending through the steel framing a minimum of three exposed threads.

b. All fasteners shall have rust-inhibitive coating suitable for the installation in which they are being used, or be manufactured from material not susceptible to corrosion.

c. An airspace that provides drainage shall be permitted to contain mortar from construction.

Reason: This code change is intended to acknowledge that the airspace behind a well-constructed, code-compliant brick veneer will never be completely devoid of mortar. No matter how careful an experienced, seasoned mason is in constructing the veneer, some small amount of mortar from construction will be found in the airspace. Such an airspace, along with code-mandated water-resistant barrier, flashing and weep holes, has long provided a proven drainage system to keep the backing and interior dry and to direct water to the exterior. This is evidenced by the many brick veneer buildings that have performed well and have not experienced any interior water issues even though they undoubtedly have some mortar in their airspace.

Historically, architects, engineers, building code officials and building owners have readily-recognized the difference between a brick veneer with a code-compliant airspace and one that was not. However, in the litigious society that we now find ourselves living in, the airspaces of some brick veneer buildings that previously would have been deemed acceptable are now called into question well after the buildings have been occupied even though the buildings are not experiencing any water damage or drainage issues associated with the brick veneer wall system. This clarification to the code is proposed to acknowledge that the airspace may contain some mortar from construction as long as it provides drainage.

Cost Impact: Will not increase the cost of construction

This code change proposal is a clarification of the existing code language. It is intended to acknowledge and reflect more closely the common practice used in the field for the construction of anchored stone and masonry veneer construction. As such, there should be no cost impact.

**Report of Committee Action
Hearings**

Committee Action:

Approved as Submitted

Committee Reason: The committee approved this proposal based on the proponents published reason statement.

Assembly Action:

None

Final Action Results

RB376-16

AS

[←BACK](#)

[←BACK](#)

Code Change No: **G10-16 Part IV**

Original Proposal

Section: R202

Proponent: Julie Ruth, JRuth Code Consulting, representing American Architectural Manufacturers Association (julruth@aol.com)

THIS IS A 4 PART CODE CHANGE. PART I WILL BE HEARD BY THE IBC-STRUCTURAL CODE COMMITTEE. PART II WILL BE HEARD BY THE IECC-COMMERCIAL CODE COMMITTEE. PART III WILL BE HEARD BY THE IECC-RESIDENTIAL CODE COMMITTEE. PART IV WILL BE HEARD BY THE IRC-BUILDING CODE COMMITTEE. SEE THE TENTATIVE HEARING ORDER FOR THESE COMMITTEES.

Revise as follows:

[RB] SKYLIGHT AND SLOPED GLAZING. Glass or other transparent or translucent glazing material installed at a slope of 15 degrees (0.26 rad) or more from vertical. ~~Glazing materials in skylights, including unit skylights, tubular daylighting devices, and glazing materials in solariums, sunrooms, roofs and sloped walls are included in this definition.~~

Reason: This revision clarifies the types of products that are included in the category of "skylights" and brings the IECC more closely in alignment with the IRC.

Cost Impact: Will not increase the cost of construction
The proposal simply clarifies which products fall under the category of "skylight", and by default, which do not. It will not impact the cost of construction

Report of Committee Action Hearings

Committee Action:

Approved as Submitted

Committee Reason: This proposal cleans up and expands the definition.

Assembly Action

None

Final Action Results

G10-16 Part IV

AS

RB173-16[←BACK](#)

R401.2 Requirements. Foundations shall be capable of resisting all loads from roof uplift and building overturn. Foundation uplift for light-frame wood or steel buildings shall be calculated or determined from Table R401.1. Masonry buildings within the dimensional scope of Table R401.1 shall be assumed to be of adequate weight so as not to require uplift resistance greater than that provided by the structure and any normal foundation. Foundation construction shall also be capable of accommodating all gravity loads according to Section R301 and of transmitting the resulting loads to the supporting soil. Fill soils that support footings and foundations shall be designed, installed and tested in accordance with accepted engineering practice. Gravel fill used as footings for wood and precast concrete foundations shall comply with Section R403.

RB176-16[←BACK](#)

R403.1.1 Minimum size. The minimum width, W, and thickness, T, for concrete footings shall be in accordance with Tables R403.1(1) through R403.1(3) and Figure R403.1(1) or R403.1.3, as applicable. Minimum sizes for concrete and masonry footings shall also be as required to provide adequate resistance to uplift and overturn of the building as determined from Table R401.1 and Section R403.1.2 or as calculated using engineered design in accordance with the *Florida Building Code, Building*. The footing width shall be based on the load-bearing value of the soil in accordance with Table R401.4.1. Footing projections, P, shall be not less than 2 inches (51 mm) and shall not exceed the thickness of the footing. Footing thickness and projection for fireplaces shall be in accordance with Section R1001.2. The size of footings supporting piers and columns shall be based on the tributary load and allowable soil pressure in accordance with Table R401.4.1. Footings for wood foundations shall be in accordance with the details set forth in Section R403.2, and Figures R403.1(2) and R403.1(3).

RB259-16

SECTION R610
IMPACT-RESISTANT COVERINGS

[←BACK](#)

R610.1 Impact resistant coverings shall be tested at 1.5 times the design pressure (positive or negative) expressed in pounds per square feet as determined by the Florida Building Code-Building Section 1609 for which the specimen is to be tested. The design pressures, as determined from Section 1609 of the Florida Building Code-Building or ASCE 7, are permitted to be multiplied by 0.6.

R610.1.1

Impact resistant coverings shall be labeled in accordance with the provisions of Section R610.

R610.2. Labels. A permanent label shall be provided by the product approval holder on all impact resistant coverings.

R610.2.1 The following information shall be included on the labels on impact resistant coverings:

1. Product approval holder name and address.
2. All applicable methods of approval. Methods of approval include, but, are not limited to Miami-Dade NOA; Florida Building Commission, TDI Product Evaluation; ICC-ES.
3. The test standard or standards specified at Section R301.2.1.2, including standards referenced within the test standards specified at Section R301.2.1.2 used to demonstrate code compliance.
4. For products with a Florida Product Approval Number or a Miami-Dade County Building and Neighborhood Compliance Department Notice of Acceptance Number (NOA), such numbers shall be included on the label.

R610.3 Location of label.

The location of the label on the impact resistant covering shall be as follows:

1. Accordions: Bottom of the locking bar or center mate facing the exterior or outside.
2. Rollup: On the bottom of the hood facing the exterior or outside or on the bottom slat facing the exterior or outside.
3. Bahama Awning or Colonial Hinged: On the bottom, placed on the back of the shutter.
4. Panels: For metal and plastic panels the label may be embossed or printed spaced not more than every three (3) lineal feet on each panel. The label shall be applied by the holder of the product approval and shall face the exterior or outside.
5. Framed products: The label shall be on the side or bottom facing the

exterior or outside.

6. Labels on all other products shall face the exterior or outside.

R610.4 Installation. All impact resistant coverings shall be installed in accordance with the manufacturer's installation instructions and in accordance with the product approval. Installation instructions shall be provided and shall be available to inspection personnel on the job site. Opening protection components, fasteners, and other parts evaluated by an approved product evaluation entity, certification agency, testing laboratory, architect, or engineer and approved by the holder of the product approval may be interchangeable in opening protection assemblies provided that the opening protection component(s) provide equal or greater structural performance and durability as demonstrated by testing in accordance with approved test standards.

RB282-16

[←BACK](#)

R703.1.2 Wind resistance. Wall coverings, backing materials and their attachments shall be capable of resisting wind loads in accordance with Tables R301.2(2) and R301.2(3) for walls using an effective wind area of 10 square feet. Wind-pressure resistance of the siding and backing materials shall be determined by ASTM E 330 or other applicable standard test methods. Where wind-pressure resistance is determined by design analysis, data from approved design standards and analysis conforming to generally accepted engineering practice shall be used to evaluate the siding and backing material and its fastening. All applicable failure modes including bending rupture of siding, fastener withdrawal and fastener head pull-through shall be considered in the testing or design analysis. Where the wall covering and the backing material resist wind load as an assembly, use of the design capacity of the assembly shall be permitted.

R703.1.2.1 Wind resistance of soffits. Soffits and their attachments shall be capable of resisting wind loads specified in Tables R301.2(2) and R301.2(3) for walls using an effective wind area of 10 square feet.

RB305-16

[←BACK](#)

R703.11.2 Installation over Foam plastic sheathing. ~~Where vinyl siding and or insulated vinyl siding used with~~ is installed over foam plastic sheathing, the vinyl siding shall comply with Section R703.11 and shall have a design wind pressure resistance in accordance with Table R703.11.2 shall be installed in accordance with Section R703.11.2.1, R703.11.2.2 or R703.11.2.3.

Exceptions:

1. Where the foam plastic sheathing is applied directly over wood structural panels, fiberboard, gypsum sheathing or other *approved* backing capable of independently

resisting the design wind pressure, the vinyl siding shall be installed in accordance with Section R703.11.1 and R703.3.3.

2. Where the vinyl siding manufacturer's product specifications provide an approved design wind pressure rating for installation over foam plastic sheathing, use of this design wind pressure rating shall be permitted and the siding shall be installed in accordance with the manufacturer's instructions.
3. Where the foam plastic sheathing and its attachment has a design wind pressure resistance complying with Sections R316.8 and R301.2.1, the vinyl siding shall be installed in accordance with Sections R703.11.1 and R703.3.3.

TABLE R703.11.2

ADJUSTED MINIMUM DESIGN WIND PRESSURE REQUIREMENT FOR VINYL SIDING

<u>Ultimate Design Wind Speed (mph)</u>	<u>Adjusted Minimum Design Wind Pressure (ASD) (psf)^{a,b}</u>					
	<u>Case 1: With interior gypsum wallboard^e</u>			<u>Case 2: Without interior gypsum wallboard^c</u>		
	<u>Exposure</u>			<u>Exposure</u>		
	<u>B</u>	<u>C</u>	<u>D</u>	<u>B</u>	<u>C</u>	<u>D</u>
110	-44.0	-61.6	-73.1	-62.9	-88.1	-104.4
115	-49.2	-68.9	-81.7	-70.3	-98.4	-116.7
120	-51.8	-72.5	-86.0	-74.0	-103.6	-122.8
130	-62.2	-87.0	-103.2	-88.8	-124.3	-147.4
>130	Not Allowed ^d					

For SI: 1 mile per hour = 0.447 m/s, 1 pound per square foot = 0.0479 kPa.

a. Linear interpolation is permitted

b. The table values are based on a maximum 30-ft mean roof height, an effective wind area of 10 ft², Wall Zone 5 (corner), and the ASD design wind pressure from Table R301.2(2) multiplied by the following adjustment factors: 2.6 (Case 1) and 3.7 (Case 2) for wind speeds less than 130 mph and 3.7 (Case 2) for wind speeds greater than 130 mph.

c. Gypsum wallboard, gypsum panel product or equivalent.

d. For the indicated wind speed condition, foam sheathing only on the exterior of frame walls with vinyl siding is not allowed unless the vinyl siding complies with an adjusted minimum design wind pressure requirement as determined in accordance with footnote b and the wall assembly is capable of resisting an impact without puncture at least equivalent to that of a wood frame wall with minimum 7/16" OSB sheathing as tested in accordance with ASTM E1886.

R703.11.2.1 Basic wind speed not exceeding 115 miles per hour and Exposure Category

B. Reserved ~~Where the ultimate design wind speed does not exceed 115 miles per hour (51 m/s), the exposure category is B and gypsum board, gypsum panel product or equivalent is~~

~~installed on the side of the wall opposite the foam plastic sheathing, the minimum siding fastener penetration into wood framing shall be 1 1/4 inches (32 mm) using minimum 0.120-inch-diameter (3 mm) nail (shank) with a minimum 0.313-inch-diameter head, 16 inches (406 mm) on center. The foam plastic sheathing shall be minimum 1/2-inch-thick (12.7 mm) (nominal) extruded polystyrene in accordance with ASTM C 578, 1/2-inch-thick (12.7 mm) (nominal) polyisocyanurate in accordance with ASTM C 1289 or 1-inch-thick (25 mm) (nominal) expanded polystyrene in accordance with ASTM C 578.~~

R703.11.2.2 Design wind pressure rating ~~Basic wind speed exceeding 115 miles per hour or Exposure Categories C and D.~~ Reserved ~~Where the ultimate design wind speed exceeds 115 miles per hour (51 m/s), the exposure category is C or D, or all conditions of Section R703.11.2.1 are not met, the adjusted design pressure rating for the assembly shall meet or exceed the loads listed in Table R301.2(2) adjusted for height and exposure using Table R301.2(3). The design wind pressure rating of the vinyl siding for installation over solid sheathing as provided in the vinyl siding manufacturer's product specifications shall be adjusted for installation over foam plastic sheathing for the following wall assembly conditions:~~

1. Ultimate wind speeds, V_{ult} , greater than 115 mph and less than 130 mph:

a. 1. For wall assemblies with foam plastic sheathing on the exterior side and gypsum wall board, gypsum panel product or equivalent on the interior side of the wall, the vinyl siding's design wind pressure rating shall be multiplied by 0.39.

b. 2. For wall assemblies with foam plastic sheathing on the exterior side and without gypsum wall board, gypsum panel product or equivalent on the interior side of wall, the vinyl siding's design wind pressure rating shall be multiplied by 0.27. The adjusted design pressure rating for the assembly shall meet or exceed the loads listed in Tables R301.2(2) adjusted for height and exposure using Table R301.2(3).

2. Ultimate wind speeds, V_{ult} , greater than 130 mph and less than 140 mph:

The vinyl siding's design wind pressure rating shall be multiplied by 0.27.

The adjusted design pressure rating for the assembly shall meet or exceed the loads listed in Tables R301.2(2) adjusted for height and exposure using Table R301.2(3).

3 Ultimate wind speeds, V_{ult} , equal to or greater than 140 mph:

Vinyl siding shall be installed over a sheathing material designed and attached to separately resist 100% of the wind load.