

# Tracking Chart – Roofing TAC

9-Roof Assemblies				No Affirmative Recommendation	
Mod #	Proponent	Chapter	Section	Summary	Commission Action
7694	T Stafford	9	905.1.1	This proposal will require a sealed roof deck consistent with the IBHS Fortified Bronze designation.	<input type="checkbox"/> AS <input type="checkbox"/> AM <input type="checkbox"/> I <input type="checkbox"/> W <input type="checkbox"/> NAR
<b>Comment</b>					
<input checked="" type="checkbox"/> 1. Support comment. Comment sufficiently addresses the TAC's concern(s).		A1 + A2 + Original		<input type="checkbox"/> 2. Do Not Support comment. Comment does not address the TAC's concern(s).	
<input type="checkbox"/> 3. No comment is needed.				<input type="checkbox"/> 4. Straw Poll.	
				10 Yes – 0 NO	

<b>Date Submitted</b>	12/5/2018	<b>Section</b>	905.1.1	<b>Proponent</b>	T Stafford
<b>Chapter</b>	9	<b>Affects HVHZ</b>	No	<b>Attachments</b>	Yes
<b>TAC Recommendation</b>	No Affirmative Recommendation				
<b>Commission Action</b>	Pending Review				

**Comments**

**General Comments** Yes **Alternate Language** Yes

**Related Modifications****Summary of Modification**

This proposal will require a sealed roof deck consistent with the IBHS Fortified Bronze designation.

**Rationale**

This proposal will require sealing of the the roof deck that is consistent with the IBHS Fortified Home Bronze designation. See uploaded support file for the rationale and justification.

**Fiscal Impact Statement****Impact to local entity relative to enforcement of code**

No impact to local entities relative to enforcement of the code.

**Impact to building and property owners relative to cost of compliance with code**

This proposal will slightly increase cost. For roof slopes 4:12 and greater, the cost increase for a typical 2000 square foot roof will be approximately \$220. For roof slopes less than 4:12, the cost increase for a typical 2000 square foot roof will be approximately \$440.

**Impact to industry relative to the cost of compliance with code**

No impact to industry relative to cost of compliance with the code.

**Impact to small business relative to the cost of compliance with code**

No impact to small business relative to cost of compliance with the code.

**Requirements****Has a reasonable and substantial connection with the health, safety, and welfare of the general public**

This proposal will reduce the amount of water infiltration through the roof deck when roof coverings are lost due to a wind event.

**Strengthens or improves the code, and provides equivalent or better products, methods, or systems of construction**

This proposal strengthens the code by requiring a sealed roof deck to reduce the amount of water infiltration through the roof deck when roof coverings are lost due to a wind event.

**Does not discriminate against materials, products, methods, or systems of construction of demonstrated capabilities**

This proposal does not discriminate against materials, products, methods, or systems of construction of demonstrated capabilities

**Does not degrade the effectiveness of the code**

This proposal does not degrade the effectiveness of the code.

Alternate Language

2nd Comment Period

7694-A4	<b>Proponent</b>	Greg Keeler	<b>Submitted</b>	5/25/2019	<b>Attachments</b>	Yes
	<b>Rationale</b>	Data shows that the tear strength and fastener pull-through strength of synthetic underlayment exceeds that of organic felt underlayment. It would only follow, then, that if 2 layers of felt are acceptable without taping the deck joints, then so too should one layer of synthetic underlayment be acceptable.				
	<b>Fiscal Impact Statement</b>					
	<b>Impact to local entity relative to enforcement of code</b>	No				
	<b>Impact to building and property owners relative to cost of compliance with code</b>	No				
	<b>Impact to industry relative to the cost of compliance with code</b>	No				
	<b>Impact to Small Business relative to the cost of compliance with code</b>	No impact to small business relative to cost of compliance with the code.				
	<b>Requirements</b>					
	<b>Has a reasonable and substantial connection with the health, safety, and welfare of the general public</b>	Yes				
	<b>Strengthens or improves the code, and provides equivalent or better products, methods, or systems of construction</b>	Yes				
<b>Does not discriminate against materials, products, methods, or systems of construction of demonstrated capabilities</b>	Yes					
<b>Does not degrade the effectiveness of the code</b>	Yes					

Alternate Language

2nd Comment Period

7694-A2	<b>Proponent</b>	T Stafford	<b>Submitted</b>	5/23/2019	<b>Attachments</b>	Yes
	<b>Rationale</b>	This public comment simply clarifies that the provisions of this section only apply to roofs with slopes of 2:12 and greater and corrects a error in regard to wood shakes and shingles.				
	<b>Fiscal Impact Statement</b>					
	<b>Impact to local entity relative to enforcement of code</b>	No impact to local entity relative to enforcement of the code.				
	<b>Impact to building and property owners relative to cost of compliance with code</b>	No impact to building and property owners relative to cost of compliance with the code.				
	<b>Impact to industry relative to the cost of compliance with code</b>	No impact to industry relative to the cost of compliance with the code.				
	<b>Impact to Small Business relative to the cost of compliance with code</b>	No impact to small business relative to cost of compliance with the code.				
	<b>Requirements</b>					
	<b>Has a reasonable and substantial connection with the health, safety, and welfare of the general public</b>	This public comment clarifies the intent of the code.				
	<b>Strengthens or improves the code, and provides equivalent or better products, methods, or systems of construction</b>	This public comment improves the code by clarifying the intent.				
<b>Does not discriminate against materials, products, methods, or systems of construction of demonstrated capabilities</b>	This public comment does not discriminate against materials, products, methods, or systems of construction of demonstrated capabilities.					
<b>Does not degrade the effectiveness of the code</b>	This public comment does not degrade the effectiveness of the code.					

Alternate Language

2nd Comment Period

**7694-A1**

**Rationale**  
 This public comment simply adds the double layer of ASTM D 226 Type II or ASTM D4869 Types III or IV as a sealed roof deck option for concrete and clay tile roof coverings. This oversight was mentioned by a representative of TRI at the last Roofing TAC meeting. We request the TAC forward this public comment with the original modification to the Commission with a positive recommendation.

**Fiscal Impact Statement**

**Impact to local entity relative to enforcement of code**  
 No impact to local entities relative to enforcement of the code.

**Impact to building and property owners relative to cost of compliance with code**  
 No impact to building and property owners relative to cost of compliance with the code.

**Impact to industry relative to the cost of compliance with code**  
 No impact to industry relative to the cost of compliance with the code.

**Impact to Small Business relative to the cost of compliance with code**  
 No impact to small business relative to cost of compliance with the code.

**Requirements**

**Has a reasonable and substantial connection with the health, safety, and welfare of the general public**  
 This proposal adds another option for creating a sealed roof deck under concrete and clay tile roofs.

**Strengthens or improves the code, and provides equivalent or better products, methods, or systems of construction**  
 Improves the code by adding another option for creating a sealed roof deck under concrete and clay tile roofs.

**Does not discriminate against materials, products, methods, or systems of construction of demonstrated capabilities**  
 This proposal does not discriminate against materials, products, methods, or systems of construction of demonstrated capabilities.

**Does not degrade the effectiveness of the code**  
 This proposal does not degrade the effectiveness of the code.

**2nd Comment Period**

**R7694-G1**

**Comment:**  
 We request the Roofing TAC give this proposal another look to move this forward to Commission with a recommendation of Approved as Submitted. During the first TAC meetings, this proposal received an NAR because it did not get the 2/3 majority needed in support. However, 7 out of the 11 TAC members voted to approve this proposal.

If approved, the requirements in this proposal will significantly reduce the amount of water infiltration in homes where the primary roof covering has been lost due to high winds. These systems have been tested at IBHS lab and all provide similar reductions in water intrusion compared to a bare deck situation.

We request Approval as Submitted.

**2nd Comment Period**

**R7694-G2**

**Comment:**  
 During the March TAC meetings FRSA was ask to provide cost estimates for the proposed sealed deck criteria outlined in modifications R7694 and R7696. Attached to this comment are pricing for:

1. A Single Layer of #30 felt underlayment;
2. A Double Layer of #30;
3. For Taped Joints for plywood.

The price difference between a single layer and a double layer of # 30 is \$633.05 for a 20 square residential type roof. The price for Taped Joints is \$795.47 for the same roof size and type. These prices include typical material cost, conservative labor, burden, overhead and profit rates all established by information from several contractors and also from previous bids submitted to roof consultants.

**R905.1.1 Underlayment.** ~~Unless otherwise noted, underlayment for asphalt shingles, metal roof shingles, mineral surfaced roll roofing, slate and slate-type shingles, wood shingles, wood shakes and metal roof panels shall conform to the applicable standards listed in this chapter. Underlayment materials required to comply with ASTM D226, D1970, D4869 and D6757 shall bear a label indicating compliance to the standard designation and, if applicable, type classification indicated in Table R905.1.1. Underlayment shall be applied and attached in accordance with Section R905.1.1.1, R905.1.1.2, or R905.1.1.3 as applicable Table R905.1.1.~~

**Exception:** A reinforced synthetic underlayment that is approved as an alternate to underlayment complying with ASTM D226 Type II or ASTM D4869 Type IV, and having a minimum tear strength of 15 lbf in accordance with ASTM D1970 or ASTM D4533 of 20 pounds and a minimum tensile strength of 20 lbf/inch in accordance with ASTM D5035 shall be permitted. This underlayment shall be installed and attached in accordance with the underlayment attachment methods of Table R905.1.1.1 for the applicable roof covering and slope, ~~except metal cap nails shall be required where the ultimate design wind speed,  $V_{ult}$ , equals or exceeds 150 mph.~~

**R905.1.1.1 Underlayment for asphalt, metal, mineral surfaced, slate and slate-type roof coverings.** Underlayment for asphalt shingles, metal roof shingles, mineral surfaced roll roofing, slate and slate-type shingles, wood shingles, wood shakes and metal roof panels shall comply with one of the following methods:

1. The entire roof deck shall be covered with an approved self-adhering polymer modified bitumen underlayment complying with ASTM D1970 installed in accordance with both the underlayment manufacturer's and roof covering manufacturer's installation instructions for the deck material, roof ventilation configuration and climate exposure for the roof covering to be installed.

2. A minimum 4-inch-wide (102 mm) strip of self-adhering polymer-modified bitumen membrane complying with ASTM D1970, installed in accordance with the manufacturer's instructions for the deck material, shall be applied over all joints in the roof decking. An approved underlayment in accordance with Table R905.1.1.1 for the applicable roof covering shall be applied over the entire roof over the 4-inch-wide (102 mm) membrane strips.

3. A minimum 3 3/4-inch wide (96 mm) strip of self-adhering flexible flashing tape complying with AAMA 711-13, Level 3 (for exposure up to 176° F (80° C)), installed in accordance with the manufacturer's instructions for the deck material, shall be applied over all joints in the roof decking. An approved underlayment in accordance with Table R905.1.1.1 for the applicable roof covering shall be applied over the entire roof over the 4-inch-wide (102 mm) flashing strips.

4. Two layers of ASTM D226 Type II or ASTM D4869 Type III or Type IV underlayment, or an approved synthetic underlayment complying with Section R905.1.1, shall be installed as follows: Apply a 19-inch (483 mm) strip of underlayment felt parallel to and starting at the eaves, fastened sufficiently to hold in place. Starting at the eave, apply 36-inchwide (914 mm) sheets of underlayment, overlapping successive sheets 19 inches (483 mm), end laps shall be 6 inches and shall be offset by 6 feet. The underlayment shall be attached to a nailable deck with corrosion-resistant fasteners with one row centered in the field of the sheet with a maximum fastener spacing of 12 inches (305 mm) o.c., and one row at the end and side laps fastened 6 inches (152 mm) o.c. Underlayment shall be attached using annular ring or deformed shank nails with metal or plastic caps with a nominal cap diameter of not less than 1 inch. Metal caps are required where the ultimate design wind speed,  $V_{ult}$ , equals or exceeds 170 mph. Metal caps shall have a thickness of not less than 32-gage sheet metal. Power-driven metal caps shall have a minimum thickness of 0.010 inch. Minimum thickness of the outside edge of plastic caps shall be 0.035 inch. The cap nail shank shall be not less than 0.083 inch for ring shank cap nails. Cap nail shank shall have a length sufficient to penetrate through the roof sheathing or not less than 3/4 inch into the roof sheathing.

**Exception:** Compliance with Section R905.1.1.1 is not required for structural metal panels that do not require a substrate or underlayment.

**Revise the original modification as follows:**

**R905.1.1 Underlayment.** Underlayment for roof slopes 2:12 and greater shall conform to the applicable standards listed in this chapter. Underlayment materials required to comply with ASTM D226, D1970, D4869 and D6757 shall bear a label indicating compliance to the standard designation and, if applicable, type classification indicated. Underlayment for roof slopes 2:12 and greater shall be applied and attached in accordance with Section R905.1.1.1, R905.1.1.2, or R905.1.1.3 as applicable.

**R905.1.1.1 Underlayment for asphalt, metal, mineral surfaced, slate and slate-type roof coverings.** Underlayment for asphalt shingles, metal roof shingles, mineral surfaced roll roofing, slate and slate-type shingles, ~~wood shingles, wood shakes~~ and metal roof panels shall comply with one of the following methods:

**No change to remainder of text.**

**Revise Section of the original modification as follows:**

**R905.1.1.2 Underlayment for concrete and clay tile.** Underlayment for concrete and clay tile shall comply with one of the following methods:

1. The entire roof deck shall be covered with an approved self-adhering polymer modified bitumen underlayment complying with ASTM D1970 installed in accordance with both the underlayment manufacturer's and roof covering manufacturer's installation instructions for the deck material, roof ventilation configuration and climate exposure for the roof covering to be installed.
2. A minimum 4-inch-wide (102 mm) strip of self-adhering polymer-modified bitumen membrane complying with ASTM D1970, installed in accordance with the manufacturer's instructions for the deck material, shall be applied over all joints in the roof decking. An underlayment complying with Section R905.3.3 shall be applied over the entire roof over the 4-inch-wide (102 mm) membrane strips.
3. A minimum 3 ¼-inch wide (96 mm) strip of self-adhering flexible flashing tape complying with AAMA 711-13, Level 3 (for exposure up to 176° F (80° C), installed in accordance with the manufacturer's instructions for the deck material, shall be applied over all joints in the roof decking. An underlayment complying with Section R905.3.3 shall be applied over the entire roof over the 4-inch-wide (102 mm) flashing strips.
4. Two layers of ASTM D226 Type II or ASTM D4869 Type III or Type IV underlayment shall be installed as follows: Apply a 19-inch (483 mm) strip of underlayment felt parallel to and starting at the eaves, fastened sufficiently to hold in place. Starting at the eave, apply 36-inchwide (914 mm) sheets of underlayment, overlapping successive sheets 19 inches (483 mm), end laps shall be 6 inches and shall be offset by 6 feet. The underlayment shall be attached to a nailable deck with corrosion-resistant fasteners with one row centered in the field of the sheet with a maximum fastener spacing of 12 inches (305 mm) o.c., and one row at the end and side laps fastened 6 inches (152 mm) o.c. Underlayment shall be attached using annular ring or deformed shank nails with metal or plastic caps with a nominal cap diameter of not less than 1 inch. Metal caps are required where the ultimate design wind speed,  $V_{ult}$ , equals or exceeds 170 mph. Metal caps shall have a thickness of not less than 32-gage sheet metal. Power-driven metal caps shall have a minimum thickness of 0.010 inch. Minimum thickness of the outside edge of plastic caps shall be 0.035 inch. The cap nail shank shall be not less than 0.083 inch for ring shank cap nails. Cap nail shank shall have a length sufficient to penetrate through the roof sheathing or not less than 3/4 inch into the roof sheathing.

**Exception:** Compliance with Section R905.1.1.2 is not required where a fully adhered underlayment is applied in accordance with Section R905.3.3.

**Revise as follows:**

**R905.1.1 Underlayment.** ~~Unless otherwise noted, underlayment for asphalt shingles, metal roof shingles, mineral surfaced roll roofing, slate and slate-type shingles, wood shingles, wood shakes and metal roof panels shall conform to the applicable standards listed in this chapter. Underlayment materials required to comply with ASTM D226, D1970, D4869 and D6757 shall bear a label indicating compliance to the standard designation and, if applicable, type classification indicated in Table R905.1.1. Underlayment shall be applied and attached in accordance with Section R905.1.1.1, R905.1.1.2, or R905.1.1.3 as applicable.~~ **Table R905.1.1.**

**R905.1.1.1 Underlayment for asphalt, metal, mineral surfaced, slate and slate-type roof coverings.** Underlayment for asphalt shingles, metal roof shingles, mineral surfaced roll roofing, slate and slate-type shingles, wood shingles, wood shakes and metal roof panels shall comply with one of the following methods:

1. The entire roof deck shall be covered with an approved self-adhering polymer modified bitumen underlayment complying with ASTM D1970 installed in accordance with both the underlayment manufacturer’s and roof covering manufacturer’s installation instructions for the deck material, roof ventilation configuration and climate exposure for the roof covering to be installed.

2. A minimum 4-inch-wide (102 mm) strip of self-adhering polymer-modified bitumen membrane complying with ASTM D1970, installed in accordance with the manufacturer’s instructions for the deck material, shall be applied over all joints in the roof decking. An approved underlayment in accordance with Table R905.1.1.1 for the applicable roof covering shall be applied over the entire roof over the 4-inch-wide (102 mm) membrane strips.

**Exception:** A reinforced synthetic underlayment that is approved as an alternate to underlayment complying with ASTM D226 Type II and having a minimum tear strength of 15 lbf in accordance with ASTM D1970 or ASTM D4533 of 20 pounds and a minimum tensile strength of 20 lbf/inch in accordance with ASTM D5035 shall be permitted to be applied over the entire roof over the 4-inch wide (102 mm) membrane strips. This underlayment shall be installed and attached in accordance with the underlayment attachment methods of Table R905.1.1.1 for the applicable roof covering and slope, ~~except metal cap nails shall be required where the ultimate design wind speed,  $V_{ult}$ , equals or exceeds 150 mph.~~

3. A minimum 3 ¼-inch wide (96 mm) strip of self-adhering flexible flashing tape complying with AAMA 711-13, Level 3 (for exposure up to 176° F (80° C)), installed in accordance with the manufacturer’s instructions for the deck material, shall be applied over all joints in the roof decking. An approved underlayment in accordance with Table R905.1.1.1 for the applicable roof covering shall be applied over the entire roof over the 4-inch-wide (102 mm) flashing strips.

**Exception:** A reinforced synthetic underlayment that is approved as an alternate to underlayment complying with ASTM D226 Type II and having a minimum tear strength of 15 lbf in accordance with ASTM D4533 and a minimum tensile strength of 20 lbf/inch in accordance with ASTM D5035 shall be permitted to be applied over the entire roof over the 4-inch wide (102 mm) membrane strips. This underlayment shall be installed and attached in accordance with the underlayment attachment methods of Table R905.1.1.1 for the applicable roof covering and slope.

4. Two layers of ASTM D226 Type II or ASTM D4869 Type III or Type IV underlayment shall be installed as follows: Apply a 19-inch (483 mm) strip of underlayment felt parallel to and starting at the eaves, fastened sufficiently to hold in place. Starting at the eave, apply 36-inchwide (914 mm) sheets of underlayment, overlapping successive sheets 19 inches (483 mm), end laps shall be 6 inches and shall be offset by 6 feet. The underlayment shall be attached to a nailable deck with corrosion-resistant fasteners with one row centered in the field of the sheet with a maximum fastener spacing of 12 inches (305 mm) o.c., and one row at the end and side laps fastened 6 inches (152 mm) o.c. Underlayment shall be attached using annular ring or deformed shank nails with metal or plastic caps with a nominal cap diameter of not less than 1 inch. Metal caps are required where the ultimate design wind speed,  $V_{ult}$ , equals or exceeds 170 mph. Metal caps shall have a thickness of not less than 32-gage sheet metal. Power-driven metal caps shall have a minimum thickness of 0.010 inch. Minimum thickness of the outside edge of plastic caps shall be 0.035 inch. The cap nail shank shall be not less than 0.083 inch for ring shank cap nails. Cap nail shank shall have a length sufficient to penetrate through the roof sheathing or not less than 3/4 inch into the roof sheathing.

**Exception:** Compliance with Section R905.1.1.1 is not required for structural metal panels that do not require a substrate or underlayment.

**TABLE R905.1.1.1**  
**UNDERLAYMENT WITH SELF-ADHERING STRIPS OVER ROOF DECKING JOINTS**

Roof Covering	Underlayment Type	Underlayment Attachment
---------------	-------------------	-------------------------



		2:12 = Roof Slope < 4:12	Roof Slope > 4:12
<p><u>Asphalt Shingles,</u> <u>Metal Roof Panels,</u> <u>Photovoltaic Shingles</u></p>	<p>ASTM D226 Type II ASTM D4869 Type III or IV ASTM D 6757</p>	<p>Apply in accordance with Section R905.1.1.1 Item 4 or Section R905.1.1.3 Item 3 as applicable to the type of roof covering.</p>	<p>Underlayment shall be applied shingle fashion, parallel to and starting from the eave and lapped 4 inches (51 mm), end laps shall be 6 inches and shall be offset by 6 feet. The underlayment shall be attached to a nailable deck with two staggered rows in the field of the sheet with a maximum fastener spacing of 12 inches (305 mm) o.c., and one row at the end and side laps fastened 6 inches (152 mm) o.c. Underlayment shall be attached using annular ring or deformed shank nails with metal or plastic caps with a nominal cap diameter of not less than 1 inch. Metal caps are required where the ultimate design wind speed, <math>V_{ult}</math>, equals or exceeds 170 mph. Metal caps shall have a thickness of not less than 32-gage sheet metal. Power-driven metal caps shall have a minimum thickness of 0.010 inch. Minimum thickness of the outside edge of plastic caps shall be 0.035 inch. The cap nail shank shall be not less than 0.083 inch for ring shank cap nails and 0.091 inch for smooth shank cap nails. Cap nail shank shall have a length sufficient to penetrate through the roof sheathing or not less than 3/4 inch into the roof sheathing.</p>
<p><u>Metal Roof Shingles,</u> <u>Mineral-Surface Roll Roofing, Slate and Slate-type Shingles,</u> <u>Wood Shingles,</u> <u>Wood Shakes</u></p>	<p>ASTM D226 Type II ASTM D4869 Type III or IV</p>		

**TABLE R905.1.1  
UNDERLAYMENT TABLE**

Roof Covering Section	- - Roof Slope 2:12 and Less Than 4:12 Underlayment	Underlayment Attachment*	- Roof Slope 4:12 and Greater Underlayment	Underlayment Attachment*
Asphalt shingles R905.2	ASTM D226 Type I or II ASTM D4869 Type II, III or IV ASTM D6757	1	ASTM D226 Type II ASTM D4869 Type III or IV ASTM D 6757	2
	ASTM D1970	3	ASTM D 1970	3
Concrete and Clay Tile R905.3	See Section R905.3.3			
Metal roof shingles R905.4	ASTM D226 Type I or II ASTM D4869 Type II, III or IV ASTM D6757	1	ASTM D226 Type II ASTM D4869 Type IV	2
	ASTM D1970	3	ASTM D1970	3
Mineral-surfaced roll roofing R905.5	ASTM D226 Type I or II ASTM D4869 Type II, III or IV	1	ASTM D226 Type II ASTM D4869 Type IV	2
	ASTM D1970	3	ASTMD 1970	3
Slate and slate type shingles R905.6	ASTM D226 Type I or II ASTM D4869 Type II, III or IV	1	ASTM D226 Type II ASTM D4869 Type IV	2
	ASTM D1970	3	ASTM D1970	3

<b>Wood shingles R905.7</b>	ASTM D226 Type I or II ASTM D4869 Type II, III or IV	1	ASTM D226 Type II ASTM D4869 Type IV	2
<b>Wood shakes R905.8</b>	Limited to roof slopes 4:12 and Greater		2	
<b>Metal roof panels R905.10</b>	ASTM D226 Type I or II ASTM D4869 Type II, III or IV	1	ASTM D226 Type II ASTM D4869 Type IV ASTM D6757	2
	ASTM D1970	3	ASTM D1970	3
<b>Photovoltaic Shingles R905.17</b>	ASTM D226 Type I or II ASTM D4869 Type II, III or IV ASTM D6757	1	ASTM D226 Type II ASTM D4869 Type IV ASTM D6757	2
	ASTM D1970	3	ASTM D1970	3

<sup>a</sup>Underlayment Attachment

1. Roof slopes from two units vertical in 12 units horizontal (17-percent slope), and less than four units vertical in 12 units horizontal (33-percent slope). Apply a 19-inch (483 mm) strip of underlayment felt parallel to and starting at the eaves, fastened sufficiently to hold in place. Starting at the eave, apply 36-inchwide (914 mm) sheets of underlayment, overlapping successive sheets 19 inches (483 mm), end laps shall be 6 inches and shall be offset by 6 feet. The underlayment shall be attached to a nailable deck with corrosion-resistant fasteners with one row centered in the field of the sheet with a maximum fastener spacing of 12 inches (305 mm) o.c., and one row at the end and side laps fastened 6 inches (152 mm) o.c. Underlayment shall be attached using metal or plastic cap nails with a nominal cap diameter of not less than 1 inch. Metal caps shall have a thickness of not less than 32-gage sheet metal. Power-driven metal caps shall have a minimum thickness of 0.010 inch. Minimum thickness of the outside edge of plastic caps shall be 0.035 inch. The cap nail shank shall be not less than 0.083 inch for ring shank cap nails and 0.091 inch for smooth shank cap nails. Cap nail shank shall have a length sufficient to penetrate through the roof sheathing or not less than 3/4 inch into the roof sheathing.

2. Roof slopes of four units vertical in 12 units horizontal (33-percent slope) or greater. Underlayment shall be applied shingle fashion, parallel to and starting from the eave and lapped 4 inches (51 mm), end laps shall be 6 inches and shall be offset by 6 feet. The underlayment shall be attached to a nailable deck with two staggered rows in the field of the sheet with a maximum fastener spacing of 12 inches (305 mm) o.c., and one row at the end and side laps fastened 6 inches (152 mm) o.c. Underlayment shall be attached using metal or plastic cap nails with a nominal cap diameter of not less than 1 inch. Metal caps shall have a thickness of not less than 32-gage sheet metal. Power-driven metal caps shall have a minimum thickness of 0.010 inch. Minimum thickness of the outside edge of plastic caps shall be 0.035 inch. The cap nail shank shall be not less than 0.083 inch for ring shank cap nails and 0.091 inch for smooth shank cap nails. Cap nail shank shall have a length sufficient to penetrate through the roof sheathing or not less than 3/4 inch into the roof sheathing.

3. Roof slopes from two units vertical in 12 units horizontal (17-percent slope) and greater. The entire roof deck shall be covered with an approved self-adhering polymer modified bitumen underlayment complying with ASTM D1970(2015a) installed in accordance with both the underlayment manufacturer's and roof covering manufacturer's installation instructions for the deck material, roof ventilation configuration and climate exposure for the roof covering to be installed.

**Exception:** A minimum 4-inch-wide (102 mm) strip of self-adhering polymer-modified bitumen membrane complying with ASTM D1970(2015a), installed in accordance with the manufacturer's instructions for the deck material, shall be applied over all joints in the roof decking. An approved underlayment in accordance with Table R905.1.1 for the applicable roof covering shall be applied over the entire roof over the 4-inch-wide (102 mm) membrane strips.

**R905.1.1.2 Underlayment for concrete and clay tile.** Underlayment for concrete and clay tile shall comply with one of the following methods:

1. The entire roof deck shall be covered with an approved self-adhering polymer modified bitumen underlayment complying with ASTM D1970 installed in accordance with both the underlayment manufacturer's and roof covering manufacturer's installation instructions for the deck material, roof ventilation configuration and climate exposure for the roof covering to be installed.

2. A minimum 4-inch-wide (102 mm) strip of self-adhering polymer-modified bitumen membrane complying with ASTM D1970, installed in accordance with the manufacturer's instructions for the deck material, shall be applied over all joints in the roof decking. An underlayment complying with Section R905.3.3 shall be applied over the entire roof over the 4-inch-wide (102 mm) membrane strips.

3. A minimum 3 3/4-inch wide (96 mm) strip of self-adhering flexible flashing tape complying with AAMA 711-13, Level 3 (for exposure up to 176° F (80° C), installed in accordance with the manufacturer's instructions for the deck material, shall be applied over all joints in the roof decking. An underlayment complying with Section R905.3.3 shall be applied over the entire roof over the 4-inch-wide (102 mm) flashing strips.

**Exception:** Compliance with Section R905.1.1.2 is not required where a fully adhered underlayment is applied in accordance with Section R905.3.3.

**R905.1.1.3 Underlayment for wood shakes and shingles.** Underlayment for wood shakes and shingles shall comply with one of the following methods:

1. A minimum 4-inch-wide (102 mm) strip of self-adhering polymer-modified bitumen membrane complying with ASTM D1970, installed in accordance with the manufacturer's instructions for the deck material, shall be applied over all joints in the roof decking. An approved underlayment in accordance with Table R905.1.1.1 for the applicable roof covering shall be applied over the entire roof over the 4-inch-wide (102 mm) membrane strips.

2. A minimum 3 3/4-inch wide (96 mm) strip of self-adhering flexible flashing tape complying with AAMA 711-13, Level 3 (for exposure up to 176° F (80° C)), installed in accordance with the manufacturer's instructions for the deck material, shall be applied over all joints in the roof decking. An underlayment complying with Table R905.1.1.1 for the applicable roof covering shall be applied over the entire roof over the 4-inch-wide (102 mm) flashing strips.

3. Two layers of ASTM D226 Type II or ASTM D4869 Type III or Type IV underlayment shall be installed as follows: Apply a 19-inch (483 mm) strip of underlayment felt parallel to and starting at the eaves, fastened sufficiently to hold in place. Starting at the eave, apply 36-inchwide (914 mm) sheets of underlayment, overlapping successive sheets 19 inches (483 mm), end laps shall be 6 inches and shall be offset by 6 feet. The underlayment shall be attached to a nailable deck with corrosion-resistant fasteners with one row centered in the field of the sheet with a maximum fastener spacing of 12 inches (305 mm) o.c., and one row at the end and side laps fastened 6 inches (152 mm) o.c. Underlayment shall be attached using annular ring or deformed shank nails with metal or plastic caps with a nominal cap diameter of not less than 1 inch. Metal caps are required where the ultimate design wind speed,  $V_{ult}$ , equals or exceeds 170 mph. Metal caps shall have a thickness of not less than 32-gage sheet metal. Power-driven metal caps shall have a minimum thickness of 0.010 inch. Minimum thickness of the outside edge of plastic caps shall be 0.035 inch. The cap nail shank shall be not less than 0.083 inch for ring shank cap nails. Cap nail shank shall have a length sufficient to penetrate through the roof sheathing or not less than 3/4 inch into the roof sheathing.

**R905.1.1 Underlayment.** ~~Unless otherwise noted, underlayment for asphalt shingles, metal roof shingles, mineral surfaced roll roofing, slate and slate-type shingles, wood shingles, wood shakes and metal roof panels shall conform to the applicable standards listed in this chapter. Underlayment materials required to comply with ASTM D226, D1970, D4869 and D6757 shall bear a label indicating compliance to the standard designation and, if applicable, type classification indicated in Table R905.1.1. Underlayment shall be applied and attached in accordance with Section R905.1.1.1, R905.1.1.2, or R905.1.1.3 as applicable Table R905.1.1.~~

**Exception:** ~~A reinforced synthetic underlayment that is approved as an alternate to underlayment complying with ASTM D226 Type II or ASTM D4869 Type IV, and having a minimum tear strength of 15 lbf in accordance with ASTM D1970 or ASTM D4533 of 20 pounds and a minimum tensile strength of 20 lbf/inch in accordance with ASTM D5035 shall be permitted. This underlayment shall be installed and attached in accordance with the underlayment attachment methods of Table R905.1.1.1 for the applicable roof covering and slope, except metal cap nails shall be required where the ultimate design wind speed,  $V_{ult}$ , equals or exceeds 150 mph.~~

**R905.1.1.1 Underlayment for asphalt, metal, mineral surfaced, slate and slate-type roof coverings.** ~~Underlayment for asphalt shingles, metal roof shingles, mineral surfaced roll roofing, slate and slate-type shingles, wood shingles, wood shakes and metal roof panels shall comply with one of the following methods:~~

1. The entire roof deck shall be covered with an approved self-adhering polymer modified bitumen underlayment complying with ASTM D1970 installed in accordance with both the underlayment manufacturer's and roof covering manufacturer's installation instructions for the deck material, roof ventilation configuration and climate exposure for the roof covering to be installed.

2. A minimum 4-inch-wide (102 mm) strip of self-adhering polymer-modified bitumen membrane complying with ASTM D1970, installed in accordance with the manufacturer's instructions for the deck material, shall be applied over all joints in the roof decking. An approved underlayment in accordance with Table R905.1.1.1 for the applicable roof covering shall be applied over the entire roof over the 4-inch-wide (102 mm) membrane strips.

3. A minimum 3 3/4-inch wide (96 mm) strip of self-adhering flexible flashing tape complying with AAMA 711-13, Level 3 (for exposure up to 176° F (80° C)), installed in accordance with the manufacturer's instructions for the deck material, shall be applied over all joints in the roof decking. An approved underlayment in accordance with Table R905.1.1.1 for the applicable roof covering shall be applied over the entire roof over the 4-inch-wide (102 mm) flashing strips.

4. Two layers of ASTM D226 Type II or ASTM D4869 Type III or Type IV underlayment, or an approved synthetic underlayment complying with Section R905.1.1, shall be installed as follows: Apply a 19-inch (483 mm) strip of underlayment felt parallel to and starting at the eaves, fastened sufficiently to hold in place. Starting at the eave, apply 36-inchwide (914 mm) sheets of underlayment, overlapping successive sheets 19 inches (483 mm), end laps shall be 6 inches and shall be offset by 6 feet. The underlayment shall be attached to a nailable deck with corrosion-resistant fasteners with one row centered in the field of the sheet with a maximum fastener spacing of 12 inches (305 mm) o.c., and one row at the end and side laps fastened 6 inches (152 mm) o.c. Underlayment shall be attached using annular ring or deformed shank nails with metal or plastic caps with a nominal cap diameter of not less than 1 inch. Metal caps are required where the ultimate design wind speed,  $V_{ult}$ , equals or exceeds 170 mph. Metal caps shall have a thickness of not less than 32-gage sheet metal. Power-driven metal caps shall have a minimum thickness of 0.010 inch. Minimum thickness of the outside edge of plastic caps shall be 0.035 inch. The cap nail shank shall be not less than 0.083 inch for ring shank cap nails. Cap nail shank shall have a length sufficient to penetrate through the roof sheathing or not less than 3/4 inch into the roof sheathing.

**Exception:** Compliance with Section R905.1.1.1 is not required for structural metal panels that do not require a substrate or underlayment.

Silvers Systems Incorporated  
 2415 28th Av N  
 St Petersburg, FL 33713  
 Ph: 727-823-7700

Roofing Cost and Profit Recap Report  
 Entire Job

Thursday, May 23, 2019  
 2:23 PM  
 Page 1

Sealed Deck Underlayment Estimate - Single Layer of #30

Silvers

Description	Net Amount	Markup	Gross Amount	Cost/Unit	Man Hours
Material					
07-100-010 ROOFING MATERIAL			\$396.39	19.672/SQ	
Material Subtotal			\$396.39	19.672/SQ	
	Tax	7.00%	\$27.75	1.377/SQ	
SubTotal Material			\$424.14	21.049/SQ	
Labor					
07-100-011 ROOFING LABOR			\$172.66	8.569/SQ	10.16
Labor Subtotal			\$172.66	8.569/SQ	10.16
	Labor Burden	95.00%	\$164.02	8.140/SQ	
SubTotal Labor			\$336.68	16.709/SQ	
SubContract					
SubContract Subtotal			\$0.00	0.000/SQ	
Equipment					
Equipment Subtotal			\$0.00	0.000/SQ	
Other					
Other Subtotal			\$0.00	0.000/SQ	
Miscellaneous					
Toilets	\$10.00	0.00%	\$10.00		
Permit	\$15.00	0.00%	\$15.00		
Miscellaneous Subtotal	\$25.00	0.00%	\$25.00	1.241/SQ	
Subtotal			\$785.82	38.998/SQ	
Overhead		45.00%	\$353.62	17.549/SQ	
Profit		6.00%	\$68.37	3.393/SQ	
Bond			\$0.00	0.000/SQ	
Bid Total			\$1,207.80	59.941/SQ	

Profit-To-Sell:	5.66%
Total SQ	20.150
Total Hours:	10.16
Total Mandays:	1.27
SQ/Hour	1.984
SQ/Manday	15.872

Silvers Systems Incorporated  
 2415 28th Av N  
 St Petersburg, FL 33713  
 Ph: 727-823-7700

Condition Detail Report

Thursday, May 23, 2019  
 2:25 PM  
 Page 1

Sealed Deck Underlayment Estimate - Single Layer of #30

Silvers

Description	Quantity	EU	Ord Qty	Ord Un	Unit Price	Prc Un	Ext Price
<b>Condition = Undrelayment 5/12 (2,015.00 SF)</b>							
30# Felt	2,015.00	SF	10.08	ROLLS	23.000	ROLL	\$231.73
1" Cap Nail	3,053.03	EA	3,053.03	EA	0.020	EA	\$61.06
Lab 1 Ply Nailed	20.15	SQ	1.01	MDAYS	136.000	MDAYS	\$137.05
Misc LF:							
Misc SF:							
Misc EA:							
<b>Total Undrelayment 5/12</b>							<b>\$429.83</b>
<b>Condition = Ridge (44.50 LF)</b>							
<b>CUT LINE WASTE</b>							
30# Felt	89.00	SF	0.45	ROLLS	23.000	ROLL	\$10.24
And							
OR							
Lab 1 Ply Nailed	89.00	SF	0.04	MDAYS	136.000	MDAYS	\$6.05
Misc LF:							
Misc SF:							
Misc EA:							
<b>Total Ridge</b>	<b>178.00</b>	<b>SF</b>					<b>\$16.29</b>
<b>Condition = Hip (110.56 LF)</b>							
<b>CUT LINE WASTE</b>							
30# Felt	221.12	SF	1.11	ROLLS	23.000	ROLL	\$25.43
And							
OR							
Lab 1 Ply Nailed	221.12	SF	0.11	MDAYS	136.000	MDAYS	\$15.04
Misc LF:							
Misc SF:							
Misc EA:							
<b>Total Hip</b>	<b>442.23</b>	<b>SF</b>					<b>\$40.47</b>
<b>Condition = Valley 5/12 (29.48 LF)</b>							
<b>Cut Line Waste</b>							
30# Felt	88.45	SF	0.44	ROLLS	23.000	ROLL	\$10.17
And							
OR							
Lab 1 Ply Nailed	88.45	SF	0.04	MDAYS	136.000	MDAYS	\$6.02
Misc LF:							
Misc SF:							
Misc EA:							
<b>Total Valley 5/12</b>	<b>176.89</b>	<b>SF</b>					<b>\$16.19</b>
<b>Condition = Eave Flashing (199.00 LF)</b>							
1" Cap Nail	199.00	EA	199.00	EA	0.020	EA	\$3.98
30# Felt	49.75	SF	0.25	ROLLS	23.000	ROLL	\$5.72
And							
OR							
Misc LF:							
Misc SF:							
Misc EA:							

Silvers Systems Incorporated  
 2415 28th Av N  
 St Petersburg, FL 33713  
 Ph: 727-823-7700

Condition Detail Report

Thursday, May 23, 2019  
 2:25 PM  
 Page 2

Sealed Deck Underlayment Estimate - Single Layer of #30

Silvers

Description	Quantity	EU	Ord Qty	Ord Un	Unit Price	Prc Un	Ext Price
<b>Total Eave Flashing</b>							<b>\$9.70</b>
Condition = VTR Flashing w/ 2" Lead Boot (1.00 EA)							
Cut Underlayment for Penetration	1.00	EA	0.01	MDAYS	136.000	MDAYS	\$1.70
Flashing Cement	3.00	SF	0.06	CANS	32.350	CANS	\$1.94
Misc LF:							
Misc SF:							
Misc EA:							
<b>Total VTR Flashing w/ 2" Lead Boot</b>							<b>\$3.64</b>
Condition = VTR Flashing w/ 3" Lead Boot (1.00 EA)							
Cut Underlayment for Penetration	1.00	EA	0.01	MDAYS	136.000	MDAYS	\$1.70
Flashing Cement	3.00	SF	0.06	CANS	32.350	CANS	\$1.94
Misc LF:							
Misc SF:							
Misc EA:							
<b>Total VTR Flashing w/ 3" Lead Boot</b>							<b>\$3.64</b>
Condition = VENT Large GRV (2.00 EA)							
Flashing Cement	2.00	SF	0.04	CANS	32.350	CANS	\$1.29
Cut Underlayment for Penetration	2.00	EA	0.03	MDAYS	136.000	MDAYS	\$3.40
Misc LF:							
Misc SF:							
Misc EA:							
<b>Total VENT Large GRV</b>							<b>\$4.69</b>
Condition = Flashing for 5/12 @ Electrical Riser (1.00 EA)							
Metal 1 :							
Metal 2 :							
Metal 3 :							
Metal 4 :							
Misc LF:							
Misc SF:							
Misc EA:							
Flashing Cement	1.00	SF	0.02	CANS	32.350	CANS	\$0.65
Cut Underlayment for Penetration	1.00	EA	0.01	MDAYS	136.000	MDAYS	\$1.70
<b>Total Flashing for 5/12 @ Electrical Ris</b>							<b>\$2.35</b>
<b>Job Totals:</b>							<b>\$526.80</b>

Silvers Systems Incorporated  
 2415 28th Av N  
 St Petersburg, FL 33713  
 Ph: 727-823-7700

Thursday, May 23, 2019  
 2:25 PM  
 Page 1

Condition Summary

Sealed Deck Underlayment Estimate - Single Layer of #30

Silvers

Description	Quantity	EU	0.00% Mat'l \$	0.00% Labor \$	0.00% Sub \$	0.00% Equip \$	0.00% Other \$	0.00% Total \$	Price/EU	EU
Page = Single Layer #30										
Undrelayment 5/12	2,015.00	SF	\$293	\$137	\$0	\$0	\$0	\$430	0.213	SF
Ridge	44.50	LF	\$10	\$6	\$0	\$0	\$0	\$16	0.366	LF
Hip	110.56	LF	\$25	\$15	\$0	\$0	\$0	\$40	0.366	LF
Valley 5/12	29.48	LF	\$10	\$6	\$0	\$0	\$0	\$16	0.549	LF
Eave Flashing	199.00	LF	\$10	\$0	\$0	\$0	\$0	\$10	0.049	LF
VTR Flashing w/ 2" Lead Boot	1.00	EA	\$2	\$2	\$0	\$0	\$0	\$4	3.641	EA
VTR Flashing w/ 3" Lead Boot	1.00	EA	\$2	\$2	\$0	\$0	\$0	\$4	3.641	EA
VENT Large GRV	2.00	EA	\$1	\$3	\$0	\$0	\$0	\$5	2.347	EA
Flashing for 5/12 @ Electrical Riser	1.00	EA	\$1	\$2	\$0	\$0	\$0	\$2	2.347	EA
Total Single Layer #30			\$354	\$173	\$0	\$0	\$0	\$527		
Job Totals:			\$354	\$173	\$0	\$0	\$0	\$527		



Silvers Systems Incorporated  
2415 28th Av N  
St Petersburg, FL 33713  
Ph: 727-823-7700

Thursday, May 23, 2019  
2:26 PM  
Page 1

Drawing Report  
Single Layer #30

Sealed Deck Underlayment Estimate - Single Layer of #30

Silvers

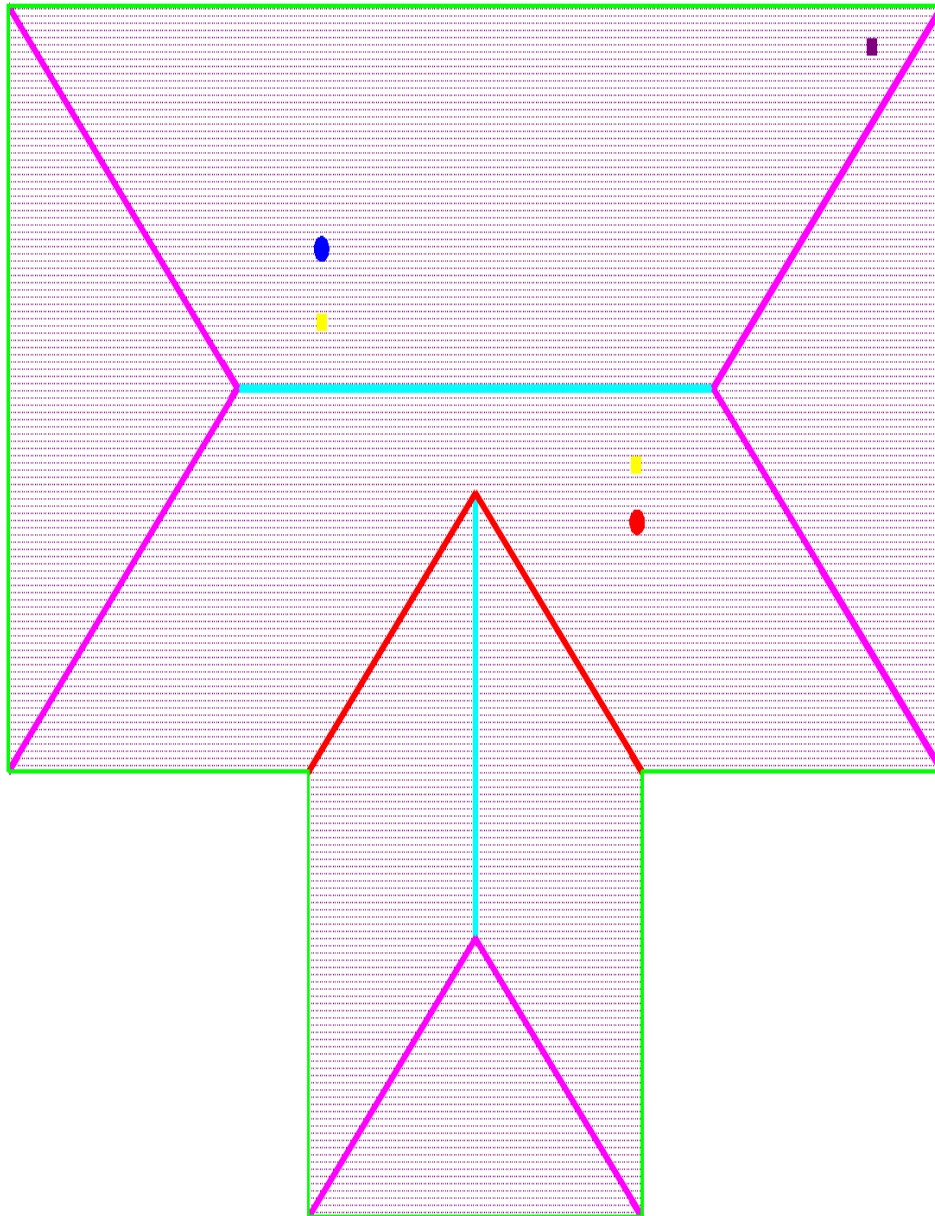

Silvers Systems Incorporated  
 2415 28th Av N  
 St Petersburg, FL 33713  
 Ph: 727-823-7700

Thursday, May 23, 2019  
 2:26 PM  
 Page 2

Drawing Report  
 Single Layer #30

Sealed Deck Underlayment Estimate - Single Layer of #30

Silvers

Legend	Pitch	Description	SF	LF	EA
	<none>	Perimeter		199.00	
	5/12	Undrelayment 5/12	2,015.00	603.09	
	<none>	Ridge		44.50	
	5/12	Hip		110.56	
	5/12	Valley 5/12		29.48	
	<none>	Eave Flashing		199.00	
	5/12	VTR Flashing w/ 2" Lead Boot			1.00
	5/12	VTR Flashing w/ 3" Lead Boot			1.00
	5/12	VENT Large GRV			2.00
	5/12	Flashing for 5/12 @ Electrical Riser			1.00

Silvers Systems Incorporated  
 2415 28th Av N  
 St Petersburg, FL 33713  
 Ph: 727-823-7700

Thursday, May 23, 2019  
 2:25 PM  
 Page 1

Labor Adjustments -Time

Sealed Deck Underlayment Estimate - Single Layer of #30 Silvers

Description	Quantity	EU	EU/MDay	EU/Hour	MDays	Hours	Ext Price	Pcs/MDay
Lab 1 Ply Nailed	398.56	SF	1,999.600	249.950	0.20	1.59	\$27.11	0.000
Lab 1 Ply Nailed	20.15	SQ	19.996	2.499	1.01	8.06	\$137.05	0.000
Cut Underlayment for Penetration	5.00	EA	79.984	9.998	0.06	0.50	\$8.50	0.000
Job Totals:					1.27	10.16	\$172.66	

Silvers Systems Incorporated  
 2415 28th Av N  
 St Petersburg, FL 33713  
 Ph: 727-823-7700

Pricing - Purchase Report

Thursday, May 23, 2019  
 2:25 PM  
 Page 1

Sealed Deck Underlayment Estimate - Single Layer of #30

Silvers

Description	Ord Qty	Ord Un	Unit Price	Unit Price	Prc Un	Ext Price
30# Felt	13.00	ROLLS	23.000		ROLL	\$299.00
Flashing Cement	1.00	CANS	32.350		CANS	\$32.35
1" Cap Nail	3,252.03	EA	0.020		EA	\$65.04
Job Totals:						\$396.39

Silvers Systems Incorporated  
 2415 28th Av N  
 St Petersburg, FL 33713  
 Ph: 727-823-7700

Roofing Cost and Profit Recap Report  
 Entire Job

Thursday, May 23, 2019  
 2:29 PM  
 Page 1

Sealed Deck Underlayment Estimate - Double Layer of #30

Silvers

Description	Net Amount	Markup	Gross Amount	Cost/Unit	Man Hours
Material					
07-100-010 ROOFING MATERIAL			\$677.98	33.647/SQ	
Material Subtotal			\$677.98	33.647/SQ	
	Tax	7.00%	\$47.46	2.355/SQ	
SubTotal Material			\$725.44	36.002/SQ	
Labor					
07-100-011 ROOFING LABOR			\$226.80	11.255/SQ	13.34
Labor Subtotal			\$226.80	11.255/SQ	13.34
	Labor Burden	95.00%	\$215.46	10.693/SQ	
SubTotal Labor			\$442.25	21.948/SQ	
SubContract					
SubContract Subtotal			\$0.00	0.000/SQ	
Equipment					
Equipment Subtotal			\$0.00	0.000/SQ	
Other					
Other Subtotal			\$0.00	0.000/SQ	
Miscellaneous					
Toilets	\$10.00	0.00%	\$10.00		
Permit	\$20.00	0.00%	\$20.00		
Miscellaneous Subtotal	\$30.00	0.00%	\$30.00	1.489/SQ	
Subtotal			\$1,197.69	59.439/SQ	
Overhead		45.00%	\$538.96	26.747/SQ	
Profit		6.00%	\$104.20	5.171/SQ	
	Bond		\$0.00	0.000/SQ	
Bid Total			\$1,840.85	91.357/SQ	

Profit-To-Sell:	5.66%
Total SQ	20.150
Total Hours:	13.34
Total Mandays:	1.67
SQ/Hour	1.510
SQ/Manday	12.083

Silvers Systems Incorporated  
 2415 28th Av N  
 St Petersburg, FL 33713  
 Ph: 727-823-7700

Condition Detail Report

Thursday, May 23, 2019  
 2:30 PM  
 Page 1

Sealed Deck Underlayment Estimate - Double Layer of #30

Silvers

Description	Quantity	EU	Ord Qty	Ord Un	Unit Price	Prc Un	Ext Price
Condition = Undrelayment 5/12 (2,015.00 SF)							
30# Felt	2,015.00	SF	10.08	ROLLS	23.000	ROLL	\$231.73
30# Felt	2,015.00	SF	10.08	ROLLS	23.000	ROLL	\$231.73
1" Cap Nail	3,250.00	EA	3,250.00	EA	0.020	EA	\$65.00
Lab 2 Ply Nailed	20.15	SQ	1.34	MDAYS	136.000	MDAYS	\$182.69
Misc LF:							
Misc SF:							
Misc EA:							
<b>Total Undrelayment 5/12</b>							<b>\$711.14</b>
Condition = Ridge (44.50 LF)							
CUT LINE WASTE							
30# Felt	89.00	SF	0.45	ROLLS	23.000	ROLL	\$10.24
30# Felt	89.00	SF	0.45	ROLLS	23.000	ROLL	\$10.24
And							
OR							
Lab 1 Ply Nailed	89.00	SF	0.04	MDAYS	136.000	MDAYS	\$6.05
Misc LF:							
Misc SF:							
Misc EA:							
<b>Total Ridge</b>	<b>267.00</b>	<b>SF</b>					<b>\$26.52</b>
Condition = Hip (110.56 LF)							
CUT LINE WASTE							
30# Felt	221.12	SF	1.11	ROLLS	23.000	ROLL	\$25.43
30# Felt	221.12	SF	1.11	ROLLS	23.000	ROLL	\$25.43
And							
OR							
Lab 1 Ply Nailed	221.12	SF	0.11	MDAYS	136.000	MDAYS	\$15.04
Misc LF:							
Misc SF:							
Misc EA:							
<b>Total Hip</b>	<b>663.35</b>	<b>SF</b>					<b>\$65.89</b>
Condition = Valley 5/12 (29.48 LF)							
Cut Line Waste							
30# Felt	88.45	SF	0.44	ROLLS	23.000	ROLL	\$10.17
30# Felt	88.45	SF	0.44	ROLLS	23.000	ROLL	\$10.17
And							
OR							
Lab 1 Ply Nailed	88.45	SF	0.04	MDAYS	136.000	MDAYS	\$6.01
Misc LF:							
Misc SF:							
Misc EA:							
<b>Total Valley 5/12</b>	<b>265.34</b>	<b>SF</b>					<b>\$26.36</b>
Condition = Eave Flashing (199.00 LF)							
1" Cap Nail	199.00	EA	199.00	EA	0.020	EA	\$3.98
30# Felt	49.75	SF	0.25	ROLLS	23.000	ROLL	\$5.72
30# Felt	49.75	SF	0.25	ROLLS	23.000	ROLL	\$5.72
And							
OR							

Silvers Systems Incorporated  
 2415 28th Av N  
 St Petersburg, FL 33713  
 Ph: 727-823-7700

Condition Detail Report

Thursday, May 23, 2019  
 2:30 PM  
 Page 2

Sealed Deck Underlayment Estimate - Double Layer of #30

Silvers

Description	Quantity	EU	Ord Qty	Ord Un	Unit Price	Prc Un	Ext Price
<b>Total Eave Flashing</b>							<b>\$15.42</b>
Condition = VTR Flashing w/ 2" Lead Boot (1.00 EA)							
Cut Underlayment for Penetration	1.00	EA	0.01	MDAYS	136.000	MDAYS	\$1.70
Cut Underlayment for Penetration	1.00	EA	0.01	MDAYS	136.000	MDAYS	\$1.70
Flashing Cement	3.00	SF	0.06	CANS	34.000	CANS	\$2.04
Misc LF:							
Misc SF:							
Misc EA:							
<b>Total VTR Flashing w/ 2" Lead Boot</b>							<b>\$5.44</b>
Condition = VTR Flashing w/ 3" Lead Boot (1.00 EA)							
Cut Underlayment for Penetration	1.00	EA	0.01	MDAYS	136.000	MDAYS	\$1.70
Cut Underlayment for Penetration	1.00	EA	0.01	MDAYS	136.000	MDAYS	\$1.70
Flashing Cement	3.00	SF	0.06	CANS	34.000	CANS	\$2.04
Misc LF:							
Misc SF:							
Misc EA:							
<b>Total VTR Flashing w/ 3" Lead Boot</b>							<b>\$5.44</b>
Condition = VENT Large GRV (2.00 EA)							
Flashing Cement	2.00	SF	0.04	CANS	34.000	CANS	\$1.36
Cut Underlayment for Penetration	2.00	EA	0.03	MDAYS	136.000	MDAYS	\$3.40
Cut Underlayment for Penetration	2.00	EA	0.03	MDAYS	136.000	MDAYS	\$3.40
Misc LF:							
Misc SF:							
Misc EA:							
<b>Total VENT Large GRV</b>							<b>\$8.16</b>
Condition = Flashing for 5/12 @ Electrical Riser (1.00 EA)							
Metal 1 :							
Metal 2 :							
Metal 3 :							
Metal 4 :							
Misc LF:							
Misc SF:							
Misc EA:							
Flashing Cement	1.00	SF	0.02	CANS	34.000	CANS	\$0.68
Cut Underlayment for Penetration	1.00	EA	0.01	MDAYS	136.000	MDAYS	\$1.70
Cut Underlayment for Penetration	1.00	EA	0.01	MDAYS	136.000	MDAYS	\$1.70
<b>Total Flashing for 5/12 @ Electrical Ris</b>							<b>\$4.08</b>
<b>Job Totals:</b>							<b>\$868.46</b>

Silvers Systems Incorporated  
 2415 28th Av N  
 St Petersburg, FL 33713  
 Ph: 727-823-7700

Thursday, May 23, 2019  
 2:30 PM  
 Page 1

Condition Summary

Sealed Deck Underlayment Estimate - Double Layer of #30

Silvers

Description	Quantity	EU	0.00% Mat'l \$	0.00% Labor \$	0.00% Sub \$	0.00% Equip \$	0.00% Other \$	0.00% Total \$	Price/EU	EU
Page = Double Layer #30										
Undrelayment 5/12	2,015.00	SF	\$528	\$183	\$0	\$0	\$0	\$711	0.353	SF
Ridge	44.50	LF	\$20	\$6	\$0	\$0	\$0	\$27	0.596	LF
Hip	110.56	LF	\$51	\$15	\$0	\$0	\$0	\$66	0.596	LF
Valley 5/12	29.48	LF	\$20	\$6	\$0	\$0	\$0	\$26	0.894	LF
Eave Flashing	199.00	LF	\$15	\$0	\$0	\$0	\$0	\$15	0.077	LF
VTR Flashing w/ 2" Lead Boot	1.00	EA	\$2	\$3	\$0	\$0	\$0	\$5	5.440	EA
VTR Flashing w/ 3" Lead Boot	1.00	EA	\$2	\$3	\$0	\$0	\$0	\$5	5.440	EA
VENT Large GRV	2.00	EA	\$1	\$7	\$0	\$0	\$0	\$8	4.080	EA
Flashing for 5/12 @ Electrical Riser	1.00	EA	\$1	\$3	\$0	\$0	\$0	\$4	4.080	EA
<b>Total Double Layer #30</b>			<b>\$642</b>	<b>\$227</b>	<b>\$0</b>	<b>\$0</b>	<b>\$0</b>	<b>\$868</b>		
<b>Job Totals:</b>			<b>\$642</b>	<b>\$227</b>	<b>\$0</b>	<b>\$0</b>	<b>\$0</b>	<b>\$868</b>		



Silvers Systems Incorporated  
2415 28th Av N  
St Petersburg, FL 33713  
Ph: 727-823-7700

Thursday, May 23, 2019  
2:31 PM  
Page 1

Drawing Report  
Double Layer #30

Sealed Deck Underlayment Estimate - Double Layer of #30

Silvers

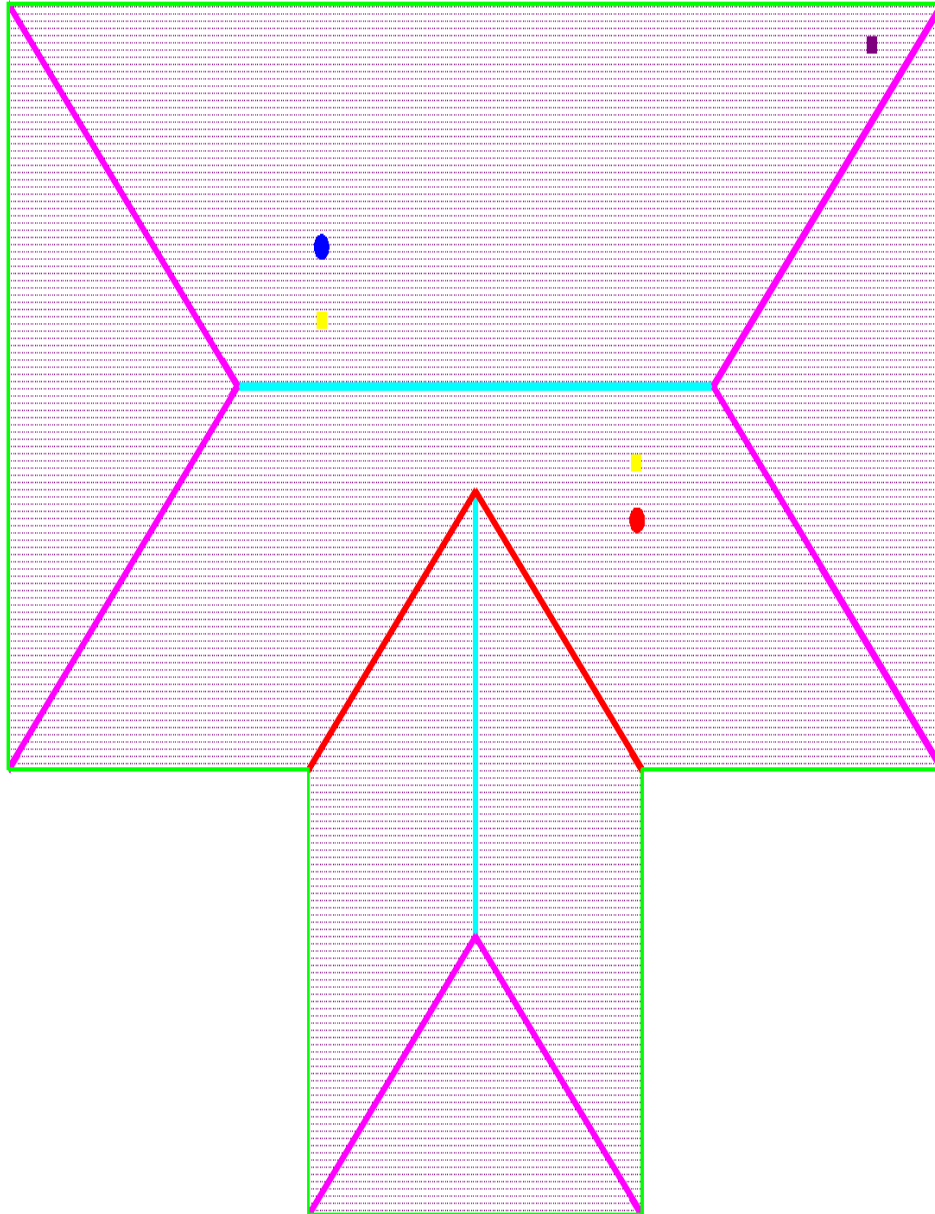











Silvers Systems Incorporated  
 2415 28th Av N  
 St Petersburg, FL 33713  
 Ph: 727-823-7700

Thursday, May 23, 2019  
 2:31 PM  
 Page 2

Drawing Report  
 Double Layer #30

Sealed Deck Underlayment Estimate - Double Layer of #30

Silvers

Legend	Pitch	Description	SF	LF	EA
	<none>	Perimeter		199.00	
	5/12	Undrelayment 5/12	2,015.00	603.09	
	<none>	Ridge		44.50	
	5/12	Hip		110.56	
	5/12	Valley 5/12		29.48	
	<none>	Eave Flashing		199.00	
	5/12	VTR Flashing w/ 2" Lead Boot			1.00
	5/12	VTR Flashing w/ 3" Lead Boot			1.00
	5/12	VENT Large GRV			2.00
	5/12	Flashing for 5/12 @ Electrical Riser			1.00

Silvers Systems Incorporated  
 2415 28th Av N  
 St Petersburg, FL 33713  
 Ph: 727-823-7700

Thursday, May 23, 2019  
 2:30 PM  
 Page 1

Labor Adjustments -Time

Sealed Deck Underlayment Estimate - Double Layer of #30 Silvers

Description	Quantity	EU	EU/MDay	EU/Hour	MDays	Hours	Ext Price	Pcs/MDay
Lab 1 Ply Nailed	398.56	SF	2,000.000	250.000	0.20	1.59	\$27.10	0.000
Lab 2 Ply Nailed	20.15	SQ	15.000	1.875	1.34	10.75	\$182.69	0.000
Cut Underlayment for Penetration	10.00	EA	80.000	10.000	0.13	1.00	\$17.00	0.000
Job Totals:					1.67	13.34	\$226.80	

Silvers Systems Incorporated  
2415 28th Av N  
St Petersburg, FL 33713  
Ph: 727-823-7700

Pricing - Purchase Report

Thursday, May 23, 2019  
2:30 PM  
Page 1

Sealed Deck Underlayment Estimate - Double Layer of #30

Silvers

Description	Ord Qty	Ord Un	Unit Price	Unit Price	Prc Un	Ext Price
30# Felt	25.00	ROLLS	23.000		ROLL	\$575.00
Flashing Cement	1.00	CANS	34.000		CANS	\$34.00
1" Cap Nail	3,449.00	EA	0.020		EA	\$68.98
Job Totals:						\$677.98

Silvers Systems Incorporated  
 2415 28th Av N  
 St Petersburg, FL 33713  
 Ph: 727-823-7700

Roofing Cost and Profit Recap Report  
 Entire Job

Thursday, May 23, 2019  
 2:04 PM  
 Page 1

Sealed Deck Underlayment Estimate - Taped Joints

Silvers

Description	Net Amount	Markup	Gross Amount	Cost/Unit	Man Hours
Material					
07-100-010 ROOFING MATERIAL			\$198.13	9.833/SQ	
Material Subtotal			\$198.13	9.833/SQ	
	Tax	7.00%	\$13.87	0.688/SQ	
SubTotal Material			\$212.00	10.521/SQ	
Labor					
07-100-011 ROOFING LABOR			\$146.44	7.267/SQ	8.61
Labor Subtotal			\$146.44	7.267/SQ	8.61
	Labor Burden	95.00%	\$139.12	6.904/SQ	
SubTotal Labor			\$285.55	14.171/SQ	
SubContract					
SubContract Subtotal			\$0.00	0.000/SQ	
Equipment					
Equipment Subtotal			\$0.00	0.000/SQ	
Other					
Other Subtotal			\$0.00	0.000/SQ	
Miscellaneous					
Toilets	\$10.00	0.00%	\$10.00		
Permit	\$10.00	0.00%	\$10.00		
Miscellaneous Subtotal	\$20.00	0.00%	\$20.00	0.993/SQ	
Subtotal			\$517.55	25.685/SQ	
Overhead		45.00%	\$232.90	11.558/SQ	
Profit		6.00%	\$45.03	2.235/SQ	
	Bond		\$0.00	0.000/SQ	
Bid Total			\$795.47	39.478/SQ	

Profit-To-Sell:	5.66%
Total SQ	20.150
Total Hours:	8.61
Total Mandays:	1.08
SQ/Hour	2.339
SQ/Manday	18.714

Silvers Systems Incorporated  
 2415 28th Av N  
 St Petersburg, FL 33713  
 Ph: 727-823-7700

Condition Detail Report

Thursday, May 23, 2019  
 2:06 PM  
 Page 1

Sealed Deck Underlayment Estimate - Taped Joints

Silvers

Description	Quantity	EU	Ord Qty	Ord Un	Unit Price	Prc Un	Ext Price
Condition = Roof Area 5/12 (2,015.00 SF)							
Misc LF:							
Misc SF:							
Misc EA:							
<b>Total Roof Area 5/12</b>	<b>0.00</b>		<b>0.00</b>				<b>\$0.00</b>
Condition = Ridge (44.50 LF)							
. CUT LINE WASTE .							
And							
OR							
Misc LF:							
Misc SF:							
Misc EA:							
<b>Total Ridge</b>	<b>0.00</b>		<b>0.00</b>				<b>\$0.00</b>
Condition = Hip (110.56 LF)							
. CUT LINE WASTE .							
And							
OR							
Misc LF:							
Misc SF:							
Misc EA:							
<b>Total Hip</b>	<b>0.00</b>		<b>0.00</b>				<b>\$0.00</b>
Condition = Valley 5/12 (29.48 LF)							
. Cut Line Waste .							
And							
OR							
Misc LF:							
Misc SF:							
Misc EA:							
<b>Total Valley 5/12</b>	<b>0.00</b>		<b>0.00</b>				<b>\$0.00</b>
Condition = Eave Flashing (199.00 LF)							
And							
OR							
Misc LF:							
Misc SF:							
Misc EA:							
<b>Total Eave Flashing</b>	<b>0.00</b>		<b>0.00</b>				<b>\$0.00</b>
Condition = Tape Joint Horizntal (417.47 LF)							
SA Seam Tape Tamko TW	417.47	LF	6.84	RL	15.000	RL	\$102.66
Install Tape Joint Horizntal	417.47	LF	0.52	MDAYS	136.000	MDAYS	\$70.97
<b>Total Tape Joint Horizntal</b>	<b>834.94</b>	<b>LF</b>					<b>\$173.63</b>

Silvers Systems Incorporated  
 2415 28th Av N  
 St Petersburg, FL 33713  
 Ph: 727-823-7700

Condition Detail Report

Thursday, May 23, 2019  
 2:06 PM  
 Page 2

Sealed Deck Underlayment Estimate - Taped Joints

Silvers

Description	Quantity	EU	Ord Qty	Ord Un	Unit Price	Prc Un	Ext Price
<b>Condition = Tape Joint Vertical (233.21 LF)</b>							
SA Seam Tape Tamko TW	233.21	LF	3.82	RL	15.000	RL	\$57.35
Install Tape Joint Vertical	233.21	LF	0.29	MDAYS	136.000	MDAYS	\$39.65
<b>Total Tape Joint Vertical</b>	<b>466.42</b>	<b>LF</b>					<b>\$96.99</b>
<b>Condition = Tape Joint Valley or Hip (140.04 LF)</b>							
SA Seam Tape Tamko TW	140.04	LF	2.30	RL	15.000	RL	\$34.44
Install Tape Joint Valley or Hip	140.04	LF	0.23	MDAYS	136.000	MDAYS	\$31.74
<b>Total Tape Joint Valley or Hip</b>	<b>280.08</b>	<b>LF</b>					<b>\$66.18</b>
<b>Condition = VTR Seam Tape (1.00 EA)</b>							
SA Seam Tape Tamko TW	2.00	LF	0.03	RL	15.000	RL	\$0.49
Install VTR Seam Tape	2.00	LF	0.00	MDAYS	136.000	MDAYS	\$0.54
Misc LF:							
Misc SF:							
Misc EA:							
<b>Total VTR Seam Tape</b>	<b>4.00</b>	<b>LF</b>					<b>\$1.04</b>
<b>Condition = VTR Seam Tape (1.00 EA)</b>							
SA Seam Tape Tamko TW	2.50	LF	0.04	RL	15.000	RL	\$0.61
Install VTR Seam Tape	2.50	LF	0.01	MDAYS	136.000	MDAYS	\$0.68
Misc LF:							
Misc SF:							
Misc EA:							
<b>Total VTR Seam Tape</b>	<b>5.00</b>	<b>LF</b>					<b>\$1.29</b>
<b>Condition = VENT Seam Tape (2.00 EA)</b>							
SA Seam Tape Tamko TW	8.00	LF	0.13	RL	15.000	RL	\$1.97
Install VENT Seam Tape	8.00	LF	0.02	MDAYS	136.000	MDAYS	\$2.18
Misc LF:							
Misc SF:							
Misc EA:							
<b>Total VENT Seam Tape</b>	<b>16.00</b>	<b>LF</b>					<b>\$4.14</b>
<b>Condition = Seam Tape @ Electrical Riser (1.00 EA)</b>							
Metal 1 :							
Metal 2 :							
Metal 3 :							
Metal 4 :							
Misc LF:							
SA Seam Tape Tamko TW	2.50	LF	0.04	RL	15.000	RL	\$0.61
Install Seam Tape @ Electrical Riser	2.50	LF	0.01	MDAYS	136.000	MDAYS	\$0.68
Misc SF:							
Misc EA:							
<b>Total Seam Tape @ Electrical Riser</b>	<b>5.00</b>	<b>LF</b>					<b>\$1.29</b>
<b>Job Totals:</b>	<b>1,611.44</b>	<b>LF</b>					<b>\$344.56</b>

Silvers Systems Incorporated  
 2415 28th Av N  
 St Petersburg, FL 33713  
 Ph: 727-823-7700

Thursday, May 23, 2019  
 2:06 PM  
 Page 1

Condition Summary

Sealed Deck Underlayment Estimate - Taped Joints

Silvers

Description	Quantity	EU	0.00% Mat'l \$	0.00% Labor \$	0.00% Sub \$	0.00% Equip \$	0.00% Other \$	0.00% Total \$	Price/EU	EU
<b>Page = Taped Joints</b>										
Tape Joint Horizntal	417.47	LF	\$103	\$71	\$0	\$0	\$0	\$174	0.416	LF
Tape Joint Vertical	233.21	LF	\$57	\$40	\$0	\$0	\$0	\$97	0.416	LF
Tape Joint Valley or Hip	140.04	LF	\$34	\$32	\$0	\$0	\$0	\$66	0.473	LF
VTR Seam Tape	1.00	EA	\$0	\$1	\$0	\$0	\$0	\$1	1.036	EA
VTR Seam Tape	1.00	EA	\$1	\$1	\$0	\$0	\$0	\$1	1.295	EA
VENT Seam Tape	2.00	EA	\$2	\$2	\$0	\$0	\$0	\$4	2.072	EA
Seam Tape @ Electrical Riser	1.00	EA	\$1	\$1	\$0	\$0	\$0	\$1	1.295	EA
<b>Total Taped Joints</b>			<b>\$198</b>	<b>\$146</b>	<b>\$0</b>	<b>\$0</b>	<b>\$0</b>	<b>\$345</b>		
<b>Job Totals:</b>			<b>\$198</b>	<b>\$146</b>	<b>\$0</b>	<b>\$0</b>	<b>\$0</b>	<b>\$345</b>		



Silvers Systems Incorporated  
2415 28th Av N  
St Petersburg, FL 33713  
Ph: 727-823-7700

Thursday, May 23, 2019  
2:08 PM  
Page 1

Drawing Report  
Taped Joints

Sealed Deck Underlayment Estimate - Taped Joints

Silvers

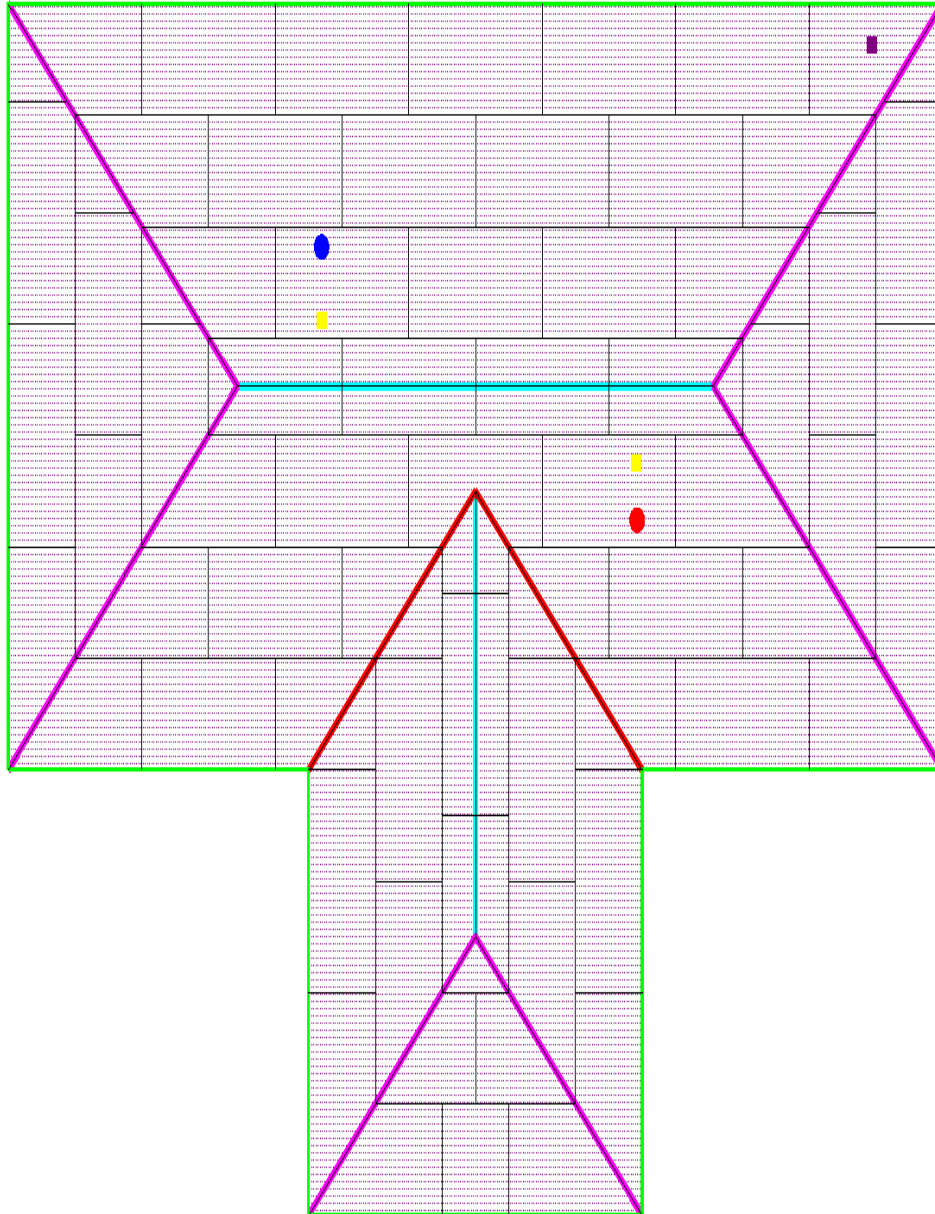

Silvers Systems Incorporated  
 2415 28th Av N  
 St Petersburg, FL 33713  
 Ph: 727-823-7700

Thursday, May 23, 2019  
 2:08 PM  
 Page 2

Drawing Report  
 Taped Joints

Sealed Deck Underlayment Estimate - Taped Joints

Silvers

Legend	Pitch	Description	SF	LF	EA
	<none>	Perimeter		199.00	
	5/12	Roof Area 5/12	2,015.00	603.09	
	<none>	Ridge		44.50	
	5/12	Hip		110.56	
	5/12	Valley 5/12		29.48	
	<none>	Eave Flashing		199.00	
	<none>	Tape Joint Horiztrntal		417.47	
	5/12	Tape Joint Vertical		233.21	
	5/12	Tape Joint Valley or Hip		140.04	
	5/12	VTR Seam Tape			1.00
	5/12	VTR Seam Tape			1.00
	5/12	VENT Seam Tape			2.00
	5/12	Seam Tape @ Electrical Riser			1.00

Silvers Systems Incorporated  
 2415 28th Av N  
 St Petersburg, FL 33713  
 Ph: 727-823-7700

Thursday, May 23, 2019  
 2:06 PM  
 Page 1

Labor Adjustments -Time

Sealed Deck Underlayment Estimate - Taped Joints

Silvers

Description	Quantity	EU	EU/MDay	EU/Hour	MDays	Hours	Ext Price	Pcs/MDay
Install Seam Tape @ Electrical Riser	2.50	LF	500.000	62.500	0.01	0.04	\$0.68	0.000
Install Tape Joint Horizontal	417.47	LF	800.000	100.000	0.52	4.17	\$70.97	0.000
Install Tape Joint Valley or Hip	140.04	LF	600.000	75.000	0.23	1.87	\$31.74	0.000
Install Tape Joint Vertical	233.21	LF	800.000	100.000	0.29	2.33	\$39.65	0.000
Install VENT Seam Tape	8.00	LF	500.000	62.500	0.02	0.13	\$2.18	0.000
Install VTR Seam Tape	4.50	LF	500.000	62.500	0.01	0.07	\$1.22	0.000
Job Totals:	805.72	LF	748.288	93.536	1.08	8.61	\$146.44	

Silvers Systems Incorporated  
 2415 28th Av N  
 St Petersburg, FL 33713  
 Ph: 727-823-7700

Pricing - Purchase Report

Thursday, May 23, 2019  
 2:06 PM  
 Page 1

Sealed Deck Underlayment Estimate - Taped Joints Silvers

Description	Ord Qty	Ord Un	Unit Price	Unit Price	Prc Un	Ext Price
SA Seam Tape Tamko TW	13.21	RL	15.000		RL	\$198.13
Job Totals:	13.21	RL			RL	\$198.13



*Where building science leads to real-world solutions.*



## Hurricane Demonstration Testing

### Insights on Wind-Driven Water Entry

*The Insurance Institute for Business & Home Safety (IBHS) Research Center 2011 hurricane season demonstration test offered an opportunity to gain insight into roof and ventilation system wind-driven water entry issues.*



This unique, full-scale study of how wind-driven water penetrates openings in residential roof systems was modeled on real world, post-event damage assessments in areas where hurricane winds were strong enough to rip off roof cover, but not strong enough to blow off roof sheathing. In such instances, significant property damage and extended occupant displacement routinely occur due to water intrusion. In addition to wind-driven water pouring in – or being blown through – cracks between roof sheathing elements when primary roof cover is damaged and the underlayment is lost, water intrusion through residential roofs can originate from attic ventilation elements (e.g., ridge vents, gable end vents, and soffit vents).

Such damage is particularly common in inland areas, where hurricane-strength winds occur, but building codes and standards are not as stringent as in coastal jurisdictions. For example, when 2005's Hurricane Wilma crossed the southern tip of Florida as a Category 2 hurricane with peak wind speed gusts of about 110 mph, she caused more than \$10 billion of damage, most of which related to roof damage and resulting water intrusion. Much of this damage occurred far inland. Other hurricanes have caused catastrophic damage as they moved well inland. For example, after Hurricane Ike made landfall in Texas, it remained strong for two days, creating Category 1 hurricane force winds as far away as Ohio (and causing more than \$1.5 billion of losses there).

Water penetration can cause extensive damage to interior finishes, furnishings and other contents, and can lead to ceiling collapse when insulation is saturated. Also, where power is lost and/or a house cannot otherwise be quickly dried out, mold growth is common. IBHS

believes that the tremendous human and financial costs associated with water penetration during hurricanes could be substantially reduced through widespread adoption of relatively simple, inexpensive changes to residential roofing systems, such as sealing the roof deck (which only costs about \$500 for an average-sized home).

Objectives for IBHS' first wind-driven water research program included:

- quantifying the relative volume of water penetration through different roof openings;
- cataloguing types of water penetration damage to different parts of a house;
- demonstrating effective individual damage mitigation techniques, such as sealing the roof deck; and,
- illustrating why sealed roof decks are core components of the IBHS FORTIFIED for Existing Homes™ and FORTIFIED for Safer Living® program requirements for hurricane-prone regions.

The building specimen designed and constructed for the demonstration was a duplex, where sheathing joints on one half of the roof deck were sealed prior to installing roofing materials and the other half was not sealed. Both halves of the roof were then covered with simple felt paper underlayment prior to installing the asphalt shingles. The building included gable ends fitted with gable end vents and one foot wide soffits at the eaves. The roof sheathing stopped short along the primary ridge so it was possible to install a ridge vent during one set of tests.

All of these features have been addressed in the IBHS FORTIFIED Existing Homes™ bronze designation, which incorporates current best practices in a systems based approach to



reducing water entry related losses in high wind events. These recommendations are also incorporated in the IBHS Roofing the Right Way guide.



Figure 1-Test duplex moving into the large test chamber at the IBHS Research Center.

The basic recommendations in the IBHS FORTIFIED Existing Homes™ bronze brochure and the IBHS Roofing the Right Way guide related to preventing or reducing wind-driven water entry include:

1. Sealing the roof deck (joints or the entire surface) to prevent water from running into the attic through the gaps between the roof sheathing panels.
2. Ensuring that soffit panels (the flat panels installed between the bottom of the eaves at the roof edge and the wall of the house) are well attached to the house so they do not blow off in high winds, thereby creating an opening through which wind-driven water could enter the attic.
3. Covering gable end vents with flat shutter panels (plywood or some other flat material) when a hurricane threatens, to keep water from being blown into the attic.

4. Ensuring that ridge vents are products that have been tested and approved for resisting wind driven water entry and that they are adequately attached using the manufacturer's recommendations for high wind installations.

The 2011 hurricane demonstration test gave IBHS its first opportunity to illustrate the relative success and importance of taking these steps to reduce the potential for water entry using high-definition photos and videos of the consequences of water entry into attic spaces during the demonstration testing. Quantitative measurements of water entry were obtained by researchers opportunistically during this demonstration testing to provide preliminary measurements and insight into the quantity of water entering into an attic through vents and between sheathing joints.

### Establishing Wind-Driven Rain Capabilities

Planning and research leading to the development of wind-driven rain capabilities at the IBHS Research Center have been ongoing for several years. IBHS provided support to the University of Florida (UF) to assist with deployment of a research disdrometer (an instrument that quantifies droplet size and rain fall rates, shown in Figure 2 on page 3) in Hurricane Ike.

IBHS followed up with partial support for a Ph.D. student to analyze rain droplet size distribution based on Hurricane Ike data, and then to use the UF wind simulator to select a commercially available spray nozzle to produce a similar distribution of rain droplet sizes in the IBHS Research Center test chamber. Thus, a realistic distribution of droplet sizes is required to achieve the same wetting patterns on buildings that occur during real world storms.

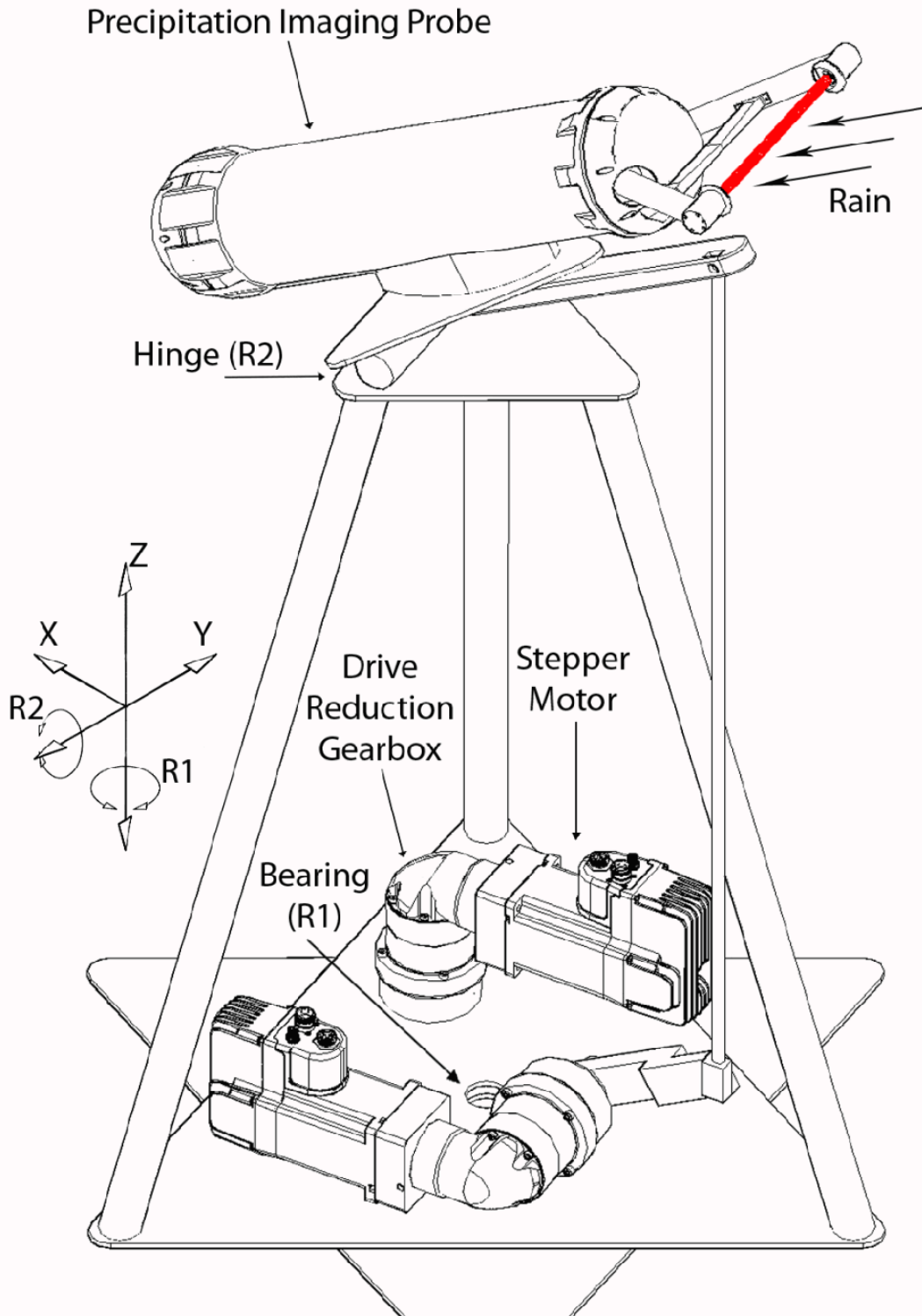

Figure 2 - Precipitation Imaging Probe (PIP) style disdrometer mounted on Florida Coastal Monitoring Program (FCMP) portable weather station for Hurricane Ike data collection by University of Florida.





This summer, the student brought the research disdrometer to the IBHS lab to conduct tests of the completed system. The validation tests demonstrated that target rain deposition rates (8 inches per hour in American Society of Testing and Materials and Florida Building Code test standards) and droplet size distributions were properly reproduced. NOTE: A Ph.D. dissertation is being written on this research and should be completed by the end of 2011.

### Measuring Water Entry Rates

When the duplex was completed, including installation of wall board and ceiling drywall, drainage panels and tracks (DrySpace™) were installed to create water collection channels between the ceiling trusses, as shown in Figure 3. These channels were outfitted with drains and pipes that allowed collected water to be captured in plastic containers arranged throughout the interior (non-attic) space in the two halves of the duplex. The drainage system was installed in a modular system that allowed the collection of water in ceiling areas roughly 10 feet long by 2 feet wide. The trusses ran from front to back of the house and the 22½ inch space between the trusses was divided into three sections, each about 10 feet long. Each drainage channel directed water to a separate numbered plastic container. Typical drain and collection locations are shown in Figure 4, Figure 5, and Figure 6 (shown on page 6). Tests were typically conducted for a 20-minute period, during which a constant wind speed was maintained and rainfall rate was set to produce 8 inches per hour on the test building (i.e., horizontally driven rain). At the completion of each test, water in the buckets was measured and quantity was recorded.

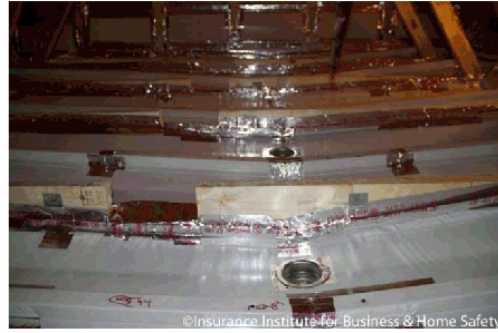

Figure 3 - Photograph of water collection channels between ceiling trusses in duplex.

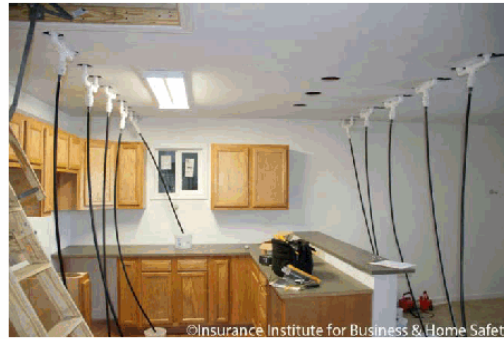

Figure 4 - Photograph of water collection drains to collection buckets in the duplex.



Figure 5 - Photograph of water collection drains to collection buckets in the duplex.



Figure 6 - Photograph of water collection drains to collection buckets in the duplex.

### Quantitative Test Program Summary

A series of quantitative tests was conducted during the time available before the scheduled hurricane demonstration. The first test sequence involved measuring water entry rates when the soffit cover was missing along the entire length of the back eave of the duplex. The opening of approximately 8.5 sq. ft. under the eave of the roof where wind and wind-driven rain could enter the attic caused by the missing soffit is typical of the observed loss of the soffit cover in strong winds. Tests were conducted for wind speeds of 30 mph, 50 mph and 70 mph, during which the wall with the open soffit faced the wind flow, as shown in Figure 7. A quartering wind test (i.e., the wall with the open soffit was oriented at 45 degrees off perpendicular to the wind direction) was also conducted with a 50 mph wind speed.

The second test sequence involved repeating soffit tests with a typical perforated vinyl soffit panel intact, thus quantifying differences in water entry for typical soffits that remain undamaged vs. soffit material blown off during an event. For this round of quantification, tests were conducted at 50 mph and 70 mph with the wall with the soffit facing the wind, and at 50 mph for the quartering wind case.

The third test sequence focused on measuring water entry through the gable end vent. These tests were conducted with 30 mph and 50 mph wind-driven rain beating directly against the gable end. During these tests, soffits were covered with typical perforated vinyl soffit panel material.



Figure 7 - Photographs of the water entry quantification testing for the open soffit case with the wall facing the wind flow: top) whole duplex; and bottom) close-up of the open soffit area.

Following the soffit and gable end quantification test series, roof cover on the front of the duplex was blown off using high winds. Similar efforts were started for the roof surface at the back of the duplex, when a fan drive fault ended wind generation for that day. Because of schedule constraints, it was decided



to remove roof cover from the back roof surface to expose the sealed and un-sealed roof decks above the same eave where soffit water entry testing was conducted. Removal of roof cover from the front and back surfaces exposed the gap at the top of the primary ridge, so it was fitted with a Florida Building Code High Velocity Hurricane Zone approved ridge vent.

The final sequence of quantification testing included wind speeds of 50 mph with the back of the duplex facing the wind flow. This configuration put the exposed sealed and un-sealed roof decks, shown in Figure 8, perpendicular to the wind-driven rain to allow a relative comparison in the amount of water entry in the attic for each half of the roof.



Figure 8 - Photograph of the back of the duplex after shingle and underlayment removal, illustrating the sealed roof deck (on the right) and the un-sealed roof deck (on the left).

### Summary of Quantitative Test Results

Open Soffit Tests (simulating loss of soffit material during a high-wind event):

1. A wind speed of 30 mph produced a light sprinkling of drops on the water collection drainage pans within 8 feet of the open soffit. However, no water actually trickled down the drainage system to collection buckets.
2. A wind speed of 50 mph produced an overall water entry rate into the attic of about 1.3

inches per hour based on the open area of the soffit. This is about 15% of the rainfall deposited on the adjacent wall surface (8 inches per hour). Most water was within the first 10 feet of the attic space adjacent to the open soffit.

3. A wind speed of 70 mph produced an overall water entry rate into the attic of about 2.9 inches per hour based on the open area of the soffit. This is a little more than 33% of the deposition rate on the adjacent wall surface.
4. A quartering wind of 50 mph produced an uneven distribution of water in the attic, but still resulted in about 1.6 inches per hour based on the open area of the soffit. This is about 20% of the deposition rate on a wall surface that would have been facing the wind flow.

### Covered Soffit Tests (where soffit material remains in place):

- A wind speed of 50 mph resulted in water accumulation in the attic space of approximately 6% of the amount of water that entered during the same test for the open soffit case.
- A wind of 70 mph produced about 9 times more water accumulation in the attic than the 50 mph test. This was about 25% of the amount of water that entered the attic during the same test (70 mph) for the open soffit case.
- A quartering wind of 50 mph produced very little accumulation of water in the attic. The amount was about 2.5% of the water entering during the same test for the open soffit case.

### Gable End Vent Tests:

For winds of 30 mph and above, the water entry rate was about equal to the wind driven water deposition rate based on the area of the gable



end vent. There was a slight indication of less water entry for higher wind speeds, but that likely was due to missed water that was blown farther into the attic and collected in the area around the access stairs where no collection pans were in place.

#### **Exposed Roof Sheathing Tests:**

The sealed roof deck side (where joints between the roof sheathing were sealed by applying a self adhesive modified bitumen tape) experienced about one-third of the water entry experienced by the side without tape. The amount of water entry through the roof deck was unprecedented in relation to tests conducted for soffit and gable end vents. The roof deck test actually had to be stopped at 16 minutes in duration, because the 3-gallon containers collecting water from each 10 foot by 2 foot collection area were overflowing. Some water entry on the sealed roof side was due to cuts in the tape that occurred when roof cover was removed. Even holes left by nails that pulled out when roof cover was removed led to steady drips of water into the attic. On the side where roof cover was blown off (shown in Figure 9), nails tended to stay in place, which would have reduced nail hole drips. Use of ring shank nails to fasten shingles and underlayment would likely help reduce these leaks, because they will be less likely to pull out, even if roof shingles are blown off. There was no sign of leaks through the Florida Building Code High Velocity Hurricane Zone approved ridge vent.

#### **Consequences of Water Entry**

Following quantitative testing, water collection devices were removed from the structure and the required drainage holes in the ceiling were patched. Furniture was placed in the duplex to model actual living spaces. The finished structure was then subjected to a series of

wind-driven rain events modeled after Hurricane Dolly. These tests gave IBHS the opportunity to illustrate the consequences of water entry into attic spaces with compelling photos and video. Figure 10 shows photographs taken on the un-sealed roof deck side of the duplex during the demonstration testing, while Figure 11 (shown on page 9) shows a similar view on the sealed roof deck side.



Figure 9 - Photograph of the front of the duplex after shingle and underlayment removal using high winds, illustrating the sealed roof deck (on the left) and the un-sealed roof deck (on the right).



Figure 10 - Photograph of the water entry during the demonstration event on the un-sealed roof deck side of the duplex: close up of the recessed lighting in the kitchen.



Figure 11 - Photograph of the kitchen during the demonstration event on the sealed roof deck side of the duplex.

The amount of water streaming into the living space during the demonstration in the un-sealed roof deck side of the duplex, and the level of damage ultimately experienced on this half of the duplex, is typical of the level of water entry reported during real-world events. Within 45 minutes of the conclusion of testing, the kitchen ceiling in the un-sealed side of the duplex collapsed, as shown in Figure 12 and Figure 13. Shortly thereafter, the living room area ceiling also collapsed, as shown in Figure 14.



Figure 13 - Photograph of fallen portions of collapsed ceiling in the kitchen on the un-sealed roof deck side of the duplex.



Figure 12 - Photograph of collapsed ceiling in the kitchen on the un-sealed roof deck side of the duplex.



Figure 14 - Photograph of fallen portions of collapsed ceiling in the living room on the un-sealed roof deck side of the duplex.



Following the test, IBHS brought in an experienced property insurance claims adjuster to estimate the amount of damage each side of the duplex suffered. He assessed damage to the front three rooms on both sides of the duplex, including the kitchen, dining room, and family room. During a hurricane or high wind event, winds generally come from a relatively small range of directions after roof cover blows off, so damage confined to one area of a house would be typical of most people's experience. The difference between estimated repair costs on the two sides of the duplex was substantial. The loss estimate for the side without a sealed roof deck is more than three times the loss estimate for the side with the sealed roof deck. Of particular note: the furniture in the side without a sealed roof deck required replacement, while furnishings in the side with the sealed roof deck only required cleaning.

### **Conclusions and Recommendations**

These preliminary tests clearly demonstrate that the areas addressed in the IBHS FORTIFIED Existing Homes™ and Roofing the Right Way guidance are important to reducing water entry in hurricanes and other storms where wind-driven rain is a factor. Clearly, sealing the roof deck is one of the most important protective measures that can be undertaken. However, the installer should be careful to make sure that seams are securely sealed and that the drip edge is attached using typical high-wind requirements for fasteners. It is likely that the High Velocity Hurricane Zone requirements for applying roofing cement around edges of the roof would also help reduce water entry if roof cover does suffer damage in a storm.

As a preliminary study, this work suggests that much more investigation is needed to quantify the amount of water entry that can be expected

for normal construction, how much water entry is likely to be reduced with various water entry prevention measures, and how much water entry can be tolerated before costs of water entry remediation increase significantly.

**Reason:** This proposal will require sealing of the the roof deck that is consistent with the *IBHS Fortified Home Bronze* designation. When the primary roof covering is lost due to a wind event, water infiltration can cause extensive damage to interior finishes, furnishings and other contents, and can lead to ceiling collapse when insulation is saturated. Also, where power is lost and/or a building cannot otherwise be quickly dried out, mold growth is common.

While observations from recent hurricanes indicate buildings built to the Florida Building Code (FBC) are performing better than older buildings, significant roof covering loss is still occurring. Many of these buildings, while relatively undamaged structurally, experienced significant and costly damage to interior components due the loss of the primary roof covering. A sealed roof deck can significantly reduce the amount of water infiltration when the primary roof covering is lost. A demonstration test by IBHS on building with portion of the roof sealed and another portion unsealed showed significant reductions in water infiltration in the areas where the roof deck was sealed. (See attached support file *Hurricane\_Test\_Wind\_Driven\_Water\_Report*.)

While underlayment requirements in the FBC have been strengthened recently, this proposal, if approved, will take them one step further to comply with the *IBHS Fortified Home Bronze* designation. From a practical standpoint, only two changes are proposed to the current underlayment requirements in the 6<sup>th</sup> Edition (2017) FBC. First, where felt underlayments are used without membrane/flashing strips applied over the joints in the roof deck, two layers would now be required. The lap requirements currently required for low slope roofs would be required for all slopes. Fasteners for felt underlayment are required to be annular ring or deformed shank fasteners. The number of fasteners and spacing of fasteners is consistent with current requirements.

The options for using adhered underlayments are unchanged from the 6<sup>th</sup> Edition (2017) FBC.

The requirements for synthetic underlayments have been revised to be consistent with the new standard for synthetic underlayments that is near completion and expected to be published in 2019.

Preliminary observations from Hurricane Michael are also indicating that newer buildings built to the FBC are performing better but water infiltration due to roof covering loss is still a problem. This proposal, if approved, will significantly reduce the amount of water infiltration through the roof deck when roof coverings are lost.