

NOTE:
 TOILET ROOM WALL SHALL HAVE FLOOR AND WALLS
 CONSTRUCTED OF SMOOTH CORROSION RESISTANT
 AND NON ABSORBENT WATER RESISTANT
 MATERIALS TO HEIGHT OF NOT LESS THAN 4 FEET
 ABOVE THE COMPARTMENT FLOOR AT THE DRAIN
 TO COMPLY W/1204.02 FBC

ACCESSIBLE RESTROOMS NOTES	
(A)	36" REAR GRAB BAR 33" HGT (33"-36" HGT.)
(B)	42" LATERAL GRAB BAR 33" HGT (33"-36" HGT.)
(C)	20" x 17" MIN. LAVATORY (34" MAX. HGT., 29" CLEARANCE MIN. AT BOTTOM)
(D)	60" x 59" MIN. CLEAR FLOOR SPACE
(E)	32" MIN. CLEAR SPACE DOOR
(F)	17" HGT FLOOR MOUNTED W.C. (17"-19" HGT.)
(G)	SOAP DISPENSER
(H)	TOILET PAPER DISPENSER
(I)	30" x 48" MIN. CLEAR FLOOR SPACE

PROVIDE PLYWD BACKING FOR FUTURE GRAB BARS

ACCESSIBLE RESTROOM SHALL COMPLY WITH CHAPTER 11, FLORIDA ACCESSIBILITY CODE FOR BUILDING CONSTRUCTION, F.B.C. 2020.

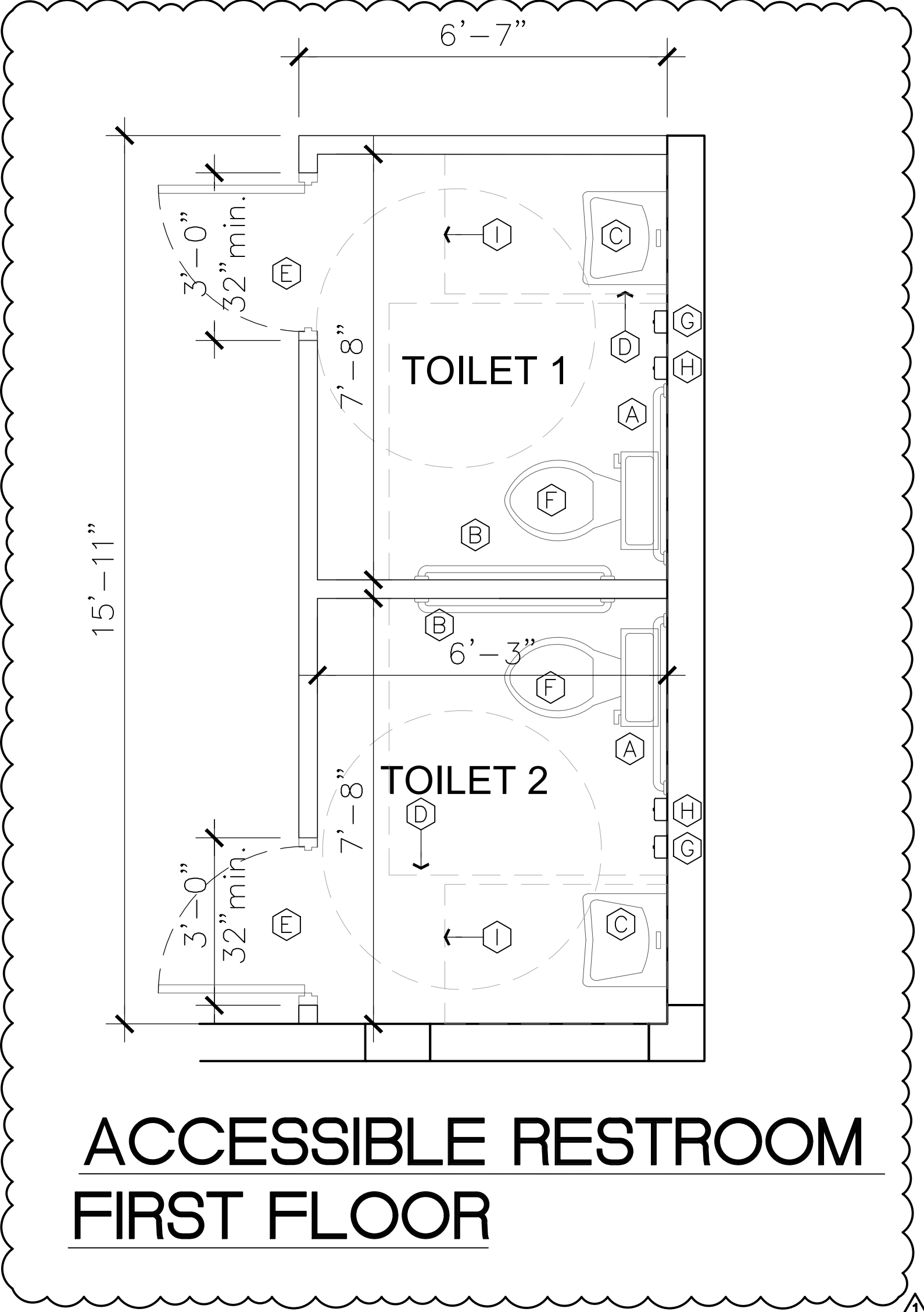

**ACCESSIBLE RESTROOM
 FIRST FLOOR**

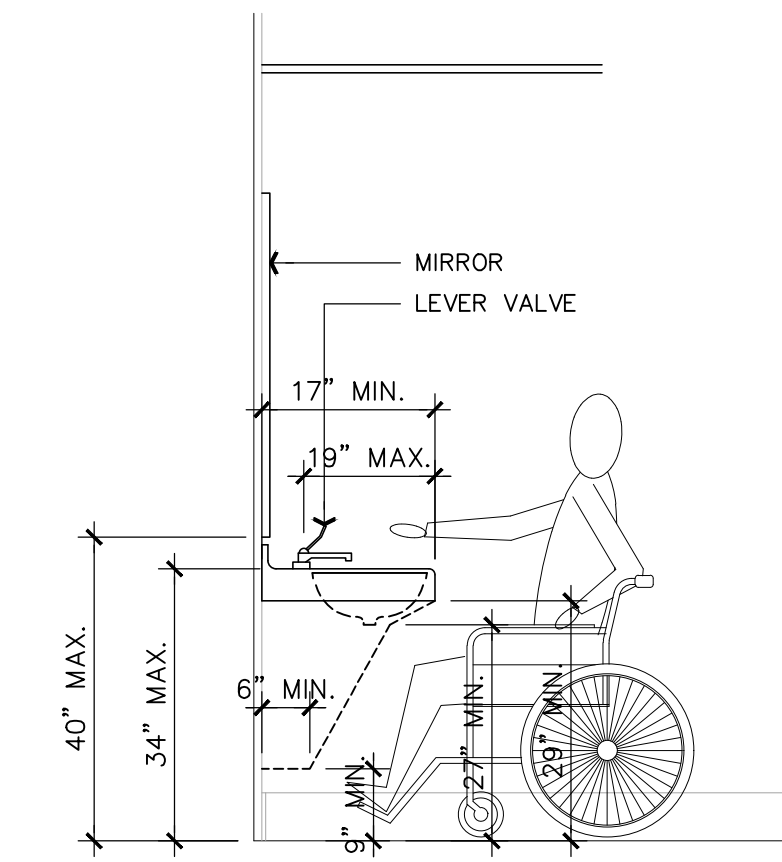

LAVATORY CLEARANCES

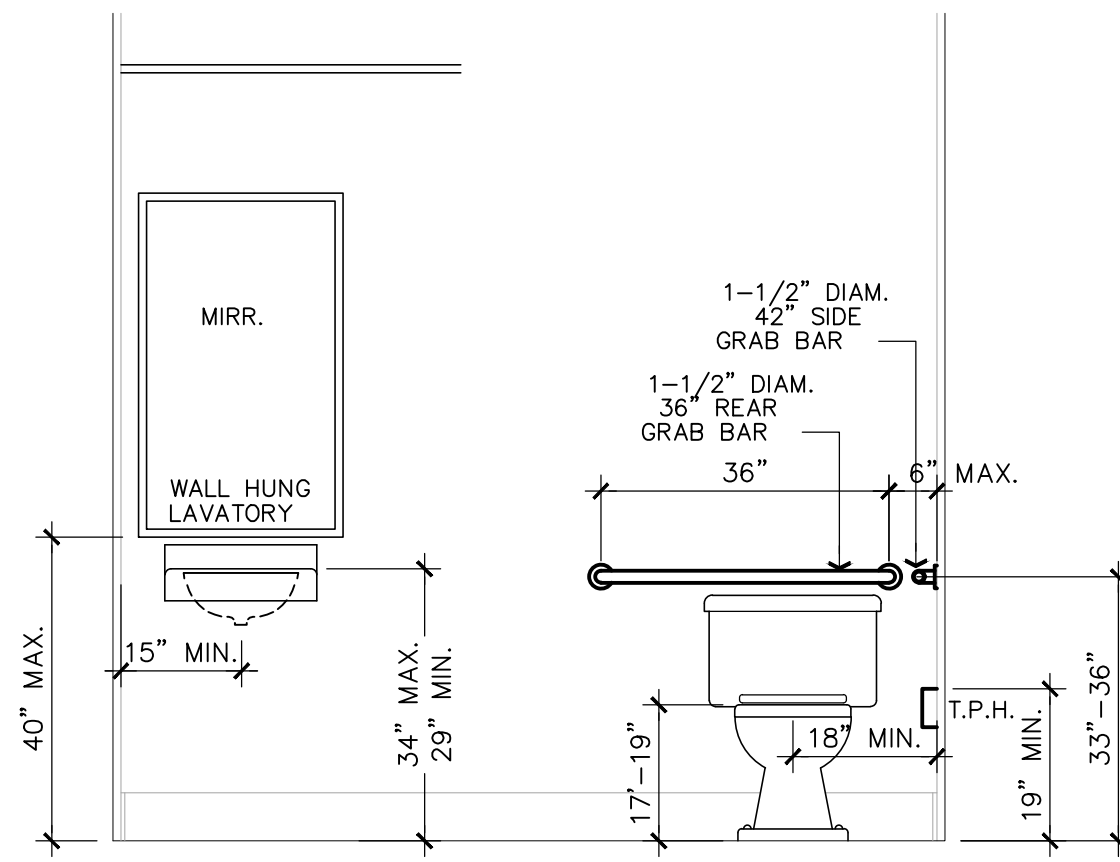

TOILET/LAVATORY CLEARANCES

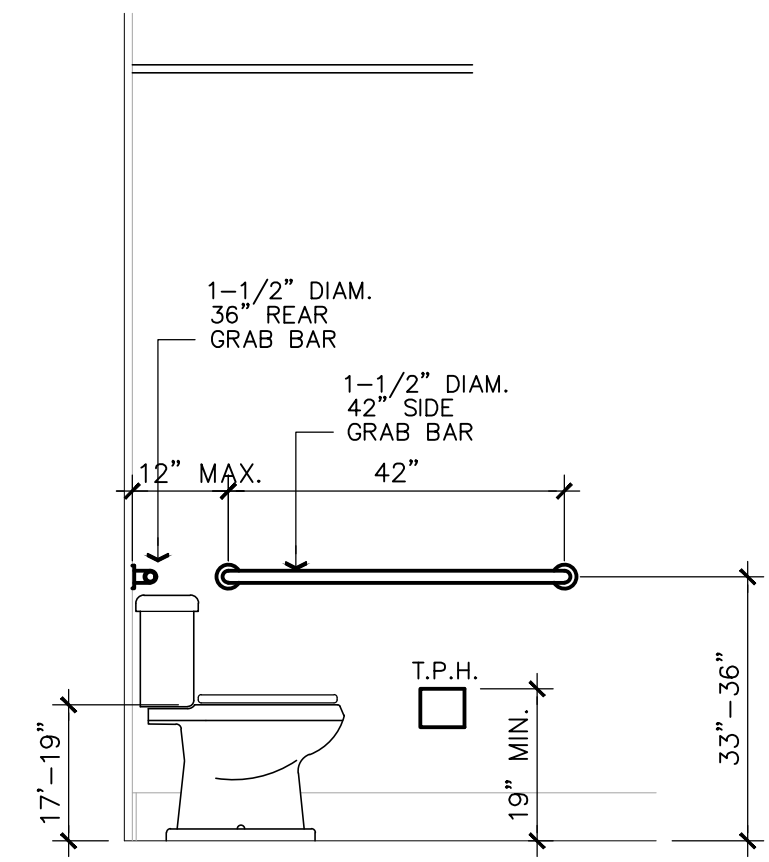

TOILET CLEARANCES

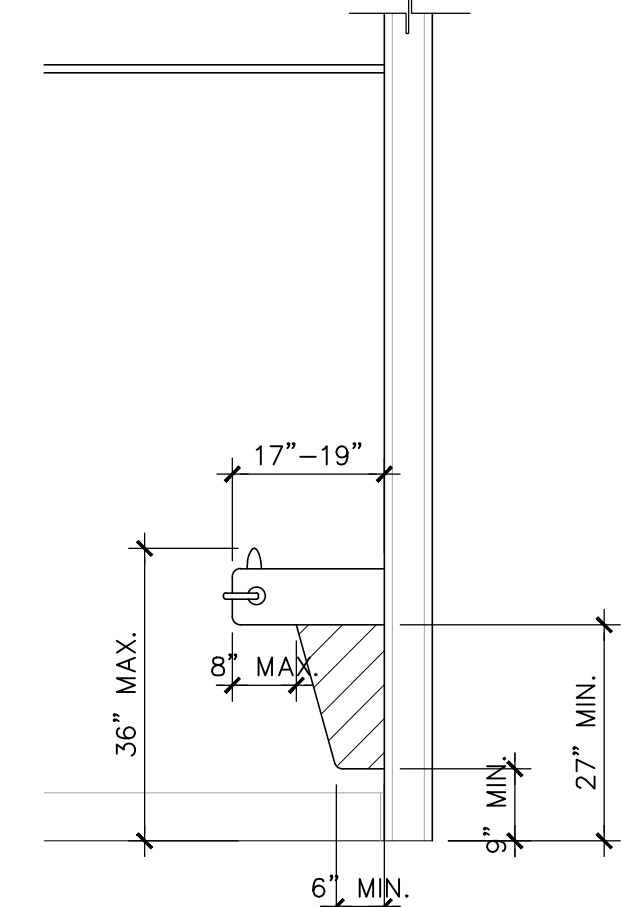

SPOUT HEIGHT AND
 KNEE CLEARANCE

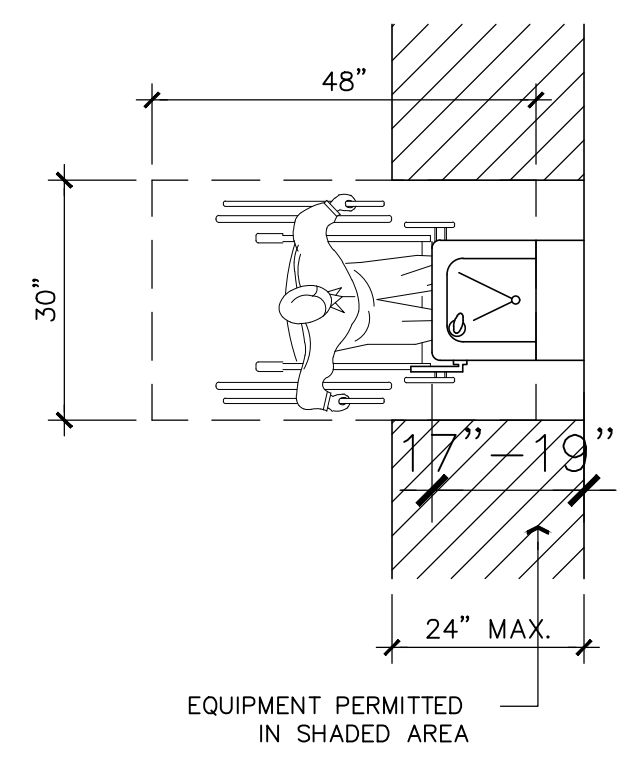

CLEAR FLOOR SPACE

DRINKING FOUNTAIN

NEW SHEET

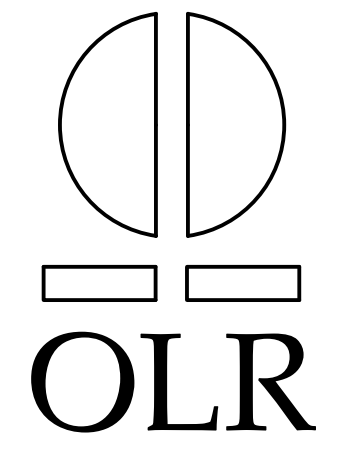

OLR
 ARCHITECT
 ORESTES LOPEZ-RECIO
 ARO009350

OWNER:
 1820 SW 3 AVE LLC
 90 SW 3ST UNIT 7 (IVY LOBBY)
 MIAMI FL 33130

PROPOSED INTERIOR
 LEGALIZATION FOR:
 1820 SW 3 AVE LLC
 1820 SW 3RD AVE
 MIAMI FLORIDA, 33129

SEAL

REVISIONS
 B.D.C. 10.12.24

DATE 07-31-24
 SCALE AS SHOWN
 DRAWN : OLR
 JOB NO. : 24-2670

A-010
 SHEET NO.: OF