

Vertical Platform Lift (VPL) Design Guide

ASME A18.1

For Models:

VPL-UL (Unenclosed Lift)

VPL-EL (Enclosure Lift)

VPL-ELP (Plexiglass Enclosure Lift)

VPL-SL (Shaftway Lift)

VPL-RL (Residential Lift)

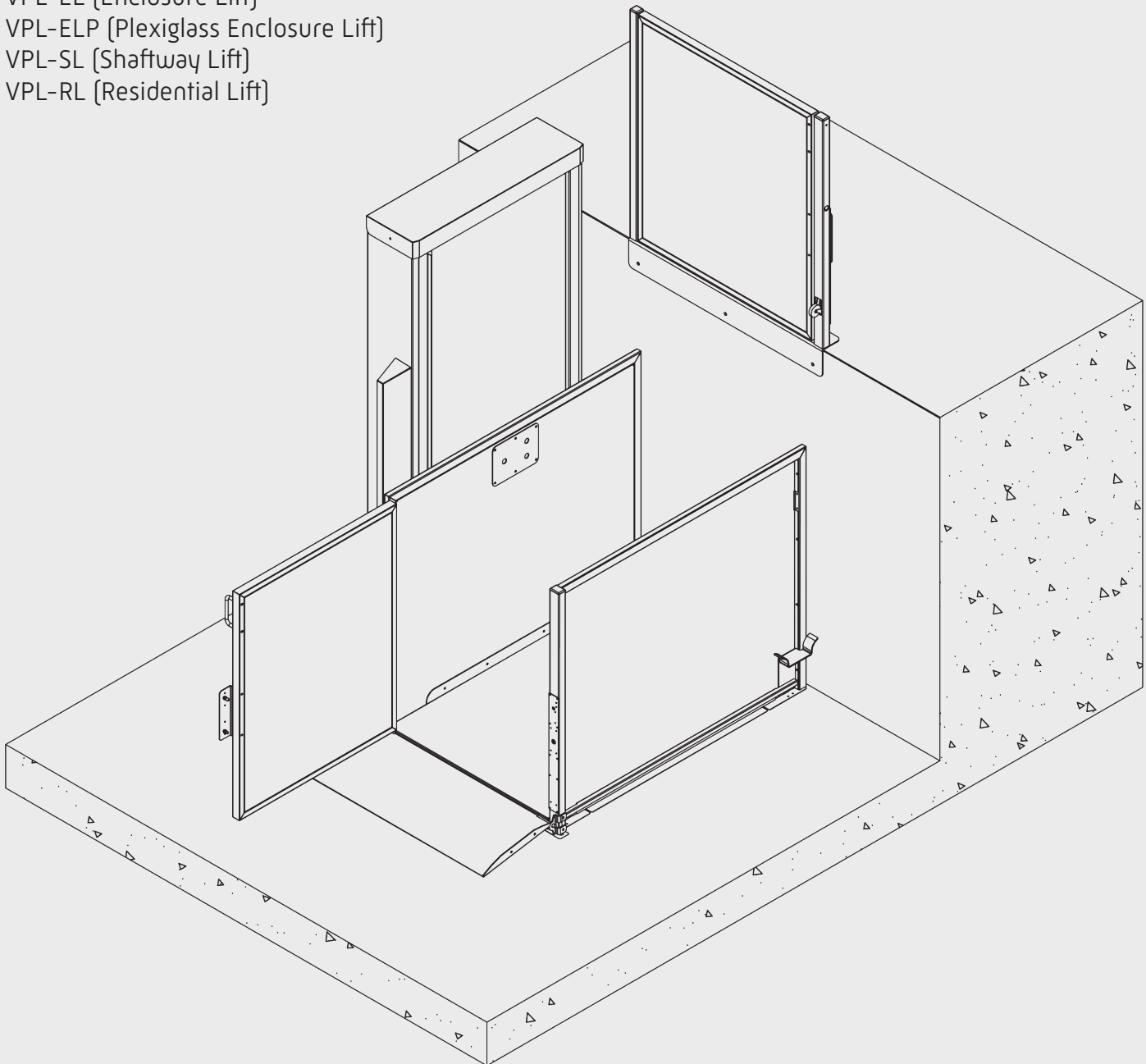



Table Of Contents

About Symmetry Elevating Solutions	2
General Rules for VPL Applications	3
Component Identification	4
Common Specifications	5
Exit Configurations	6-9
Reaction Forces	10
Pits/Ramps and Door/Gate Swing.....	11
Gates	12-13
Power Gate Operator	14
Power Door Operator.....	15
Flush Door and/or Frame.....	16
Fire-Rated Flush Door.....	17
Typical Conduit Layout.....	18
Notes.....	19

About Symmetry Elevating Solutions

Symmetry is a beautifully crafted, expertly engineered accessibility-related product line proudly **made in the U.S.A.** at the Bella Elevator LLC manufacturing plant. Promoted and sold by our  exclusive nationwide network of carefully selected Symmetry partners and associates, Symmetry offers residential elevators, vertical platform lifts (VPL), limited use/limited application (LULA) elevators and vertical reciprocating conveyors (VRC).

Strictly following national code guidelines and adhering to local jurisdiction requirements and variances, Symmetry products are ADA and ASME compliant and manufactured to meet the end users' specific needs. Symmetry Elevating Solutions representatives possess a wealth of knowledge and experience and are committed to excellence for the life of the product—before, during and after project completion.

With dealer locations spanning North America, we are equipped to meet the accessibility needs of a wide spectrum of clients, from home and business owners, to schools, municipalities and other governmental entities.

Please note that this guide is for planning purposes only, applies exclusively to national code and should not be used for construction. Prior to construction, please contact your local Symmetry Elevating Solutions representative and request a job-specific set of plans to ensure that you obtain the accurate dimensions and requirements for your project.

Your representative will also assist you to identify resources to ensure that your project plans will comply with the applicable state and local codes and the permitting authorities.

General Rules for VPL Applications

These rules have been developed as a guideline and are based on the information supplied in ICC A117.1 and ASME A18.1. Please consult your local authority having jurisdiction regarding local codes and regulations.

Platform Minimum Clear Space

- 36" x 48" in existing buildings for same side or straight through exits
- 36" x 52" in new buildings for same side or straight through exits
- 36" x 60" in existing buildings for adjacent (90 degree) exits
- 42" x 60" in new buildings for adjacent (90 degree) exits

Doors & Gates

- 32 inch minimum clear opening for a door or gate accessing the VPL from the end.
- 36 inch minimum narrow, 42 inch minimum wide in 90 degree applications.
- All doors/gates require a minimum 18 inch latch side clearance. A greater distance may need to be provided as described in ICC A117.1.
- Power-operated doors/gates are required in all applications that are not straight-through, depending on code year and AHJ approval.
- Gates must be a minimum 42 inches tall.
- Doors must have 79 inch clear inside height.
- Doors/gates must be installed flush to the interior of the hoistway.
- In unenclosed commercial applications, a platform gate and a safety pan are required.

Lift Height

- Unenclosed commercial applications cannot exceed 60 inches in travel height.
- Shaftway and enclosure applications are available at travel heights not to exceed 168 inches; up to 240 inches on Hydraulic Drive with variance.
- Some state and local jurisdictions have additional travel height restrictions.

Ramps

- Stationary ramps will project 25 inches minimum from either the edge of the running clearance (for models with a platform gate) or the outside face of the lower landing door or gate.
- Low profile ramp available with a 13" ramp, not available on unenclosed lifts.
- Retractable ramps (flip-up ramps) will project 15 inches from the edge of the platform on the lower landing side of the lift for unenclosed lifts. (Not available on tower forward.)

Pits

- The minimum depth of a pit for a VPL will be 1½ inches deep, however a 3 inch pit is recommended. If an unenclosed lift is provided without a ramp, the minimum pit depth is 3 inches.
- When a VPL is installed in a pit and in an outdoor application, the pit must have means to prevent the collection of water.

Anchoring

- The machine base must be anchored to the floor. Floor to be smooth and level with 4 inch minimum concrete thickness and capable of withstanding a 3,200 psi compressive load.
- If travel height is 60 inches or less, wall fastening is not required except in 90° applications.
- Doors and gates are not free-standing and must be anchored vertically and horizontally.

Clearances

- The running clearance on a side of the lift that will be used to enter/exit the lift must be ¾ inch minimum to ¾ inch maximum.
- The running clearance on a non-opening side of the platform must be 2 inch minimum.
- 79 inch minimum head clearance is required throughout the travel of the conveyance.

Electrical/Lighting

- Hoistway lighting of 5 ftc is required on the platform surface throughout the travel of the conveyance.
- An auxiliary light consisting of no fewer than two lamps producing 0.2 ftc on the floor and controls for not less than 4 hours, is activated automatically in the event of a power outage.
- A disconnect (provided by others) shall be a listed device conforming to NFPA 70/NEC 620.51 and shall be installed within sight of the motor controller. The disconnecting means shall be externally operable, have permanent means of locking the device in the open position and be labeled with the location of the supply side overcurrent protection means.

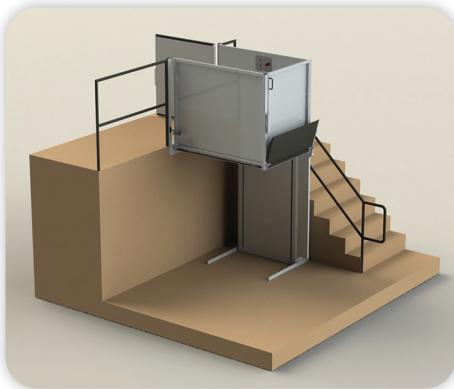
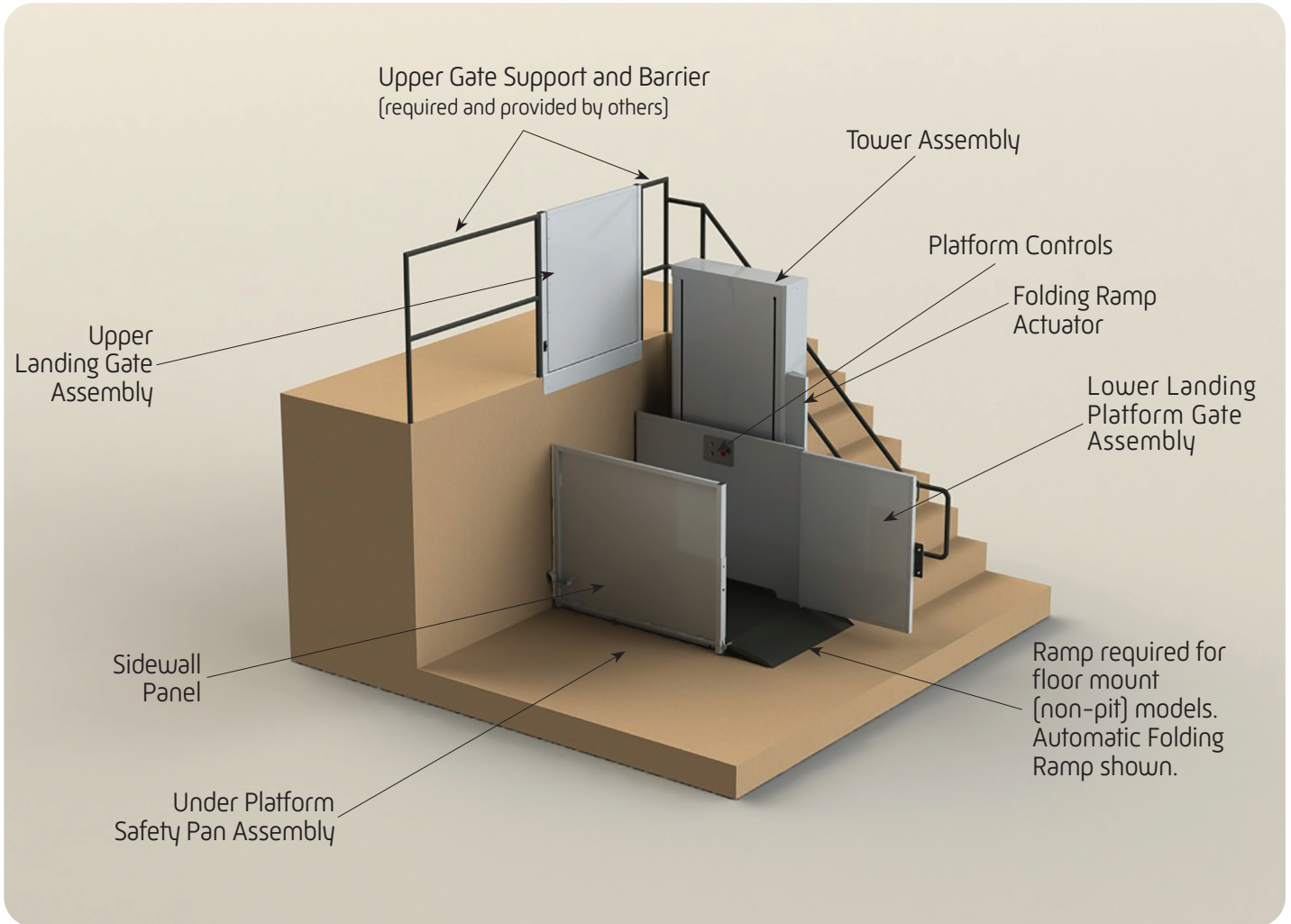

VPL-UL
(Unenclosed Lift)
with Folding Ramp

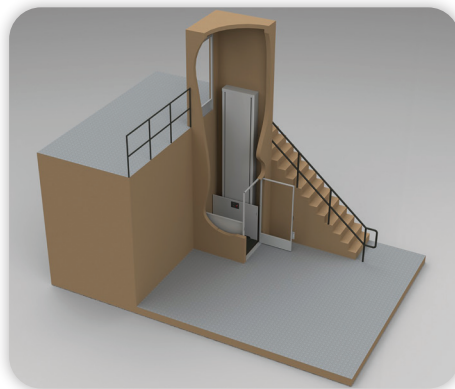

VPL-SL
(Shaftway Lift)
with Pit

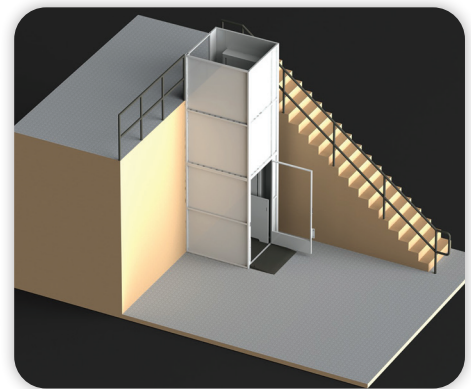

VPL-EL
(Enclosure Lift)
with Stationary Ramp

Common Specifications

For VPL

Standard Features

- Rated Capacity: 750 lbs.
- Lifting Height: Up to 168" (not available on VPL-UL) (Hydraulic units may exceed 168" with variance)
- Steel construction with powder-coated finish
- A.W.A.R.E. system (Active Wiring, Accessories, Relay and Electronics Diagnosis)*
- Constant-pressure up/down control switch installed on the platform
- Constant-pressure control station provided at each landing
- Manual lowering device
- Warranty: Four-year limited parts

Safety Features

- Grab rail (optional on VPL-RL)
- Non-skid platform surface (Black)
- Obstruction safety panel under platform (when not installed within a runway enclosure)
- Alarm (optional on VPL-RL)
- Emergency stop switch
 - Illuminated (optional on VPL-RL)
- Landing interlocks keep doors closed/locked when the platform is at another landing
- Upper final limit switch (optional on Hydraulic Drive)
- Safety lift nut for Acme Screw Drive
- Broken chain safeties for Hydraulic Drive

Optional Features

- Low Profile Carriage: 1½" pit depth (not available on VPL-UL)
- Remote mounted controller
- 230 VAC power supply
- ADA phone for indoor or outdoor applications
- Emergency platform lighting
- Full-speed battery backup
- 5 ftc LED lights with or without battery backup
- Power gate/door operators
- Flip-up ramp (VPL-UL and VPL-RL only)
- Single or double slope roof (VPL-EL and VPL-ELP only)
- Extreme weather package
- Elevator style controls

Clear Platform Sizes

(Custom sizes and designs available)

- 36"W x 54"L
- 36"W x 60"L
- 36"W x 48"L
- 42"W x 60"L

Enter/Exit Configurations

- Straight-Through
- 90°
- 3 Openings
- Same Side (not available on VPL-UL or VPL-RL)

Gate/Door Options

- 42" platform gate** (not available for VPL-SL)
- 42" landing gate**
- 80" landing gate**
- Non-Fire-rated Red Oak door†
- 1½ hour Fire-rated steel door (B Label)

Drive Options

- Acme Screw Drive: 10 fpm, 1.5 HP, 115 VAC
- Accelerated Acme Screw Drive: 20 fpm, 1.5 HP, 115 VAC
- Chain Hydraulic Drive: 17-20 fpm, 3 HP, 115 VAC (not available on VPL-RL)

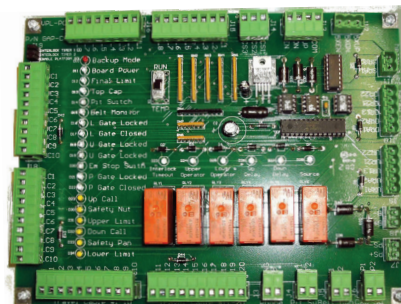

LED Diagnostic Board
(located under the main tower)

* Symmetry Elevating Solutions exclusive

** Available with optional acrylic insert

† Also available in other wood choices, by request

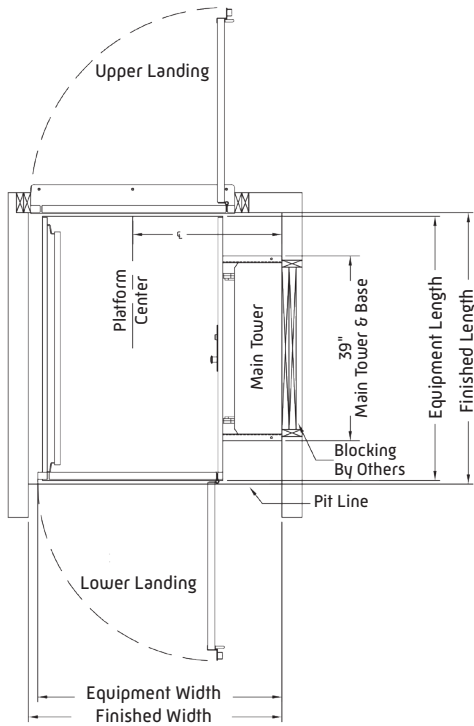

Unenclosed Design
Straight-Through With Pit

Clear Platform (W" x L")	Equipment Width	Equipment Length	Finished Width*	Finished Length	Upper Gate C/L
36" x 48"	51 ³ / ₄ "	49 ³ / ₄ "	53 ³ / ₄ "	51 ¹ / ₄ "	31 ³ / ₄ "
36" x 54"	51 ³ / ₄ "	55 ³ / ₄ "	53 ³ / ₄ "	57 ¹ / ₄ "	31 ³ / ₄ "
36" x 60"	51 ³ / ₄ "	61 ³ / ₄ "	53 ³ / ₄ "	63 ¹ / ₄ "	31 ³ / ₄ "
42" x 60"	57 ³ / ₄ "	61 ³ / ₄ "	59 ³ / ₄ "	63 ¹ / ₄ "	34 ³ / ₄ "

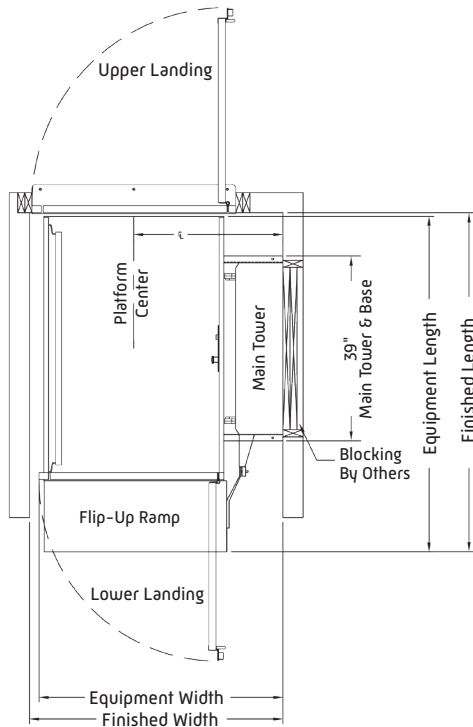

Unenclosed Design
Straight-Through With Flip-Up Ramp

Clear Platform (W" x L")	Equipment Width	Equipment Length	Finished Width*	Finished Length	Upper Gate C/L
36" x 48"	51 ³ / ₄ "	64 ³ / ₄ "	53 ³ / ₄ "	65 ¹ / ₂ "	31 ³ / ₄ "
36" x 54"	51 ³ / ₄ "	70 ³ / ₄ "	53 ³ / ₄ "	71 ¹ / ₂ "	31 ³ / ₄ "
36" x 60"	51 ³ / ₄ "	76 ³ / ₄ "	53 ³ / ₄ "	77 ¹ / ₂ "	31 ³ / ₄ "
42" x 60"	57 ³ / ₄ "	76 ³ / ₄ "	59 ³ / ₄ "	77 ¹ / ₂ "	34 ³ / ₄ "

* If platform gate is hinged opposite the main tower and a mid mount gate operator is used, add 1/2" to this dimension

Exit Configurations

Unenclosed designs

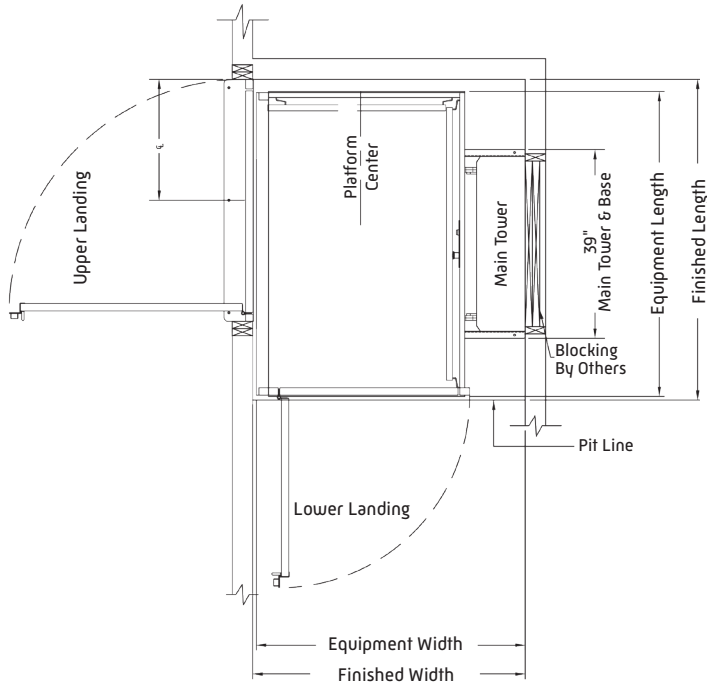

Unenclosed Design
90° With Pit

Clear Platform {W" x L"}	Equipment Width	Equipment Length	Finished Width	Finished Length	Upper Gate C/L
42" x 60"	55¾"	63"	57"	66¼"	25"

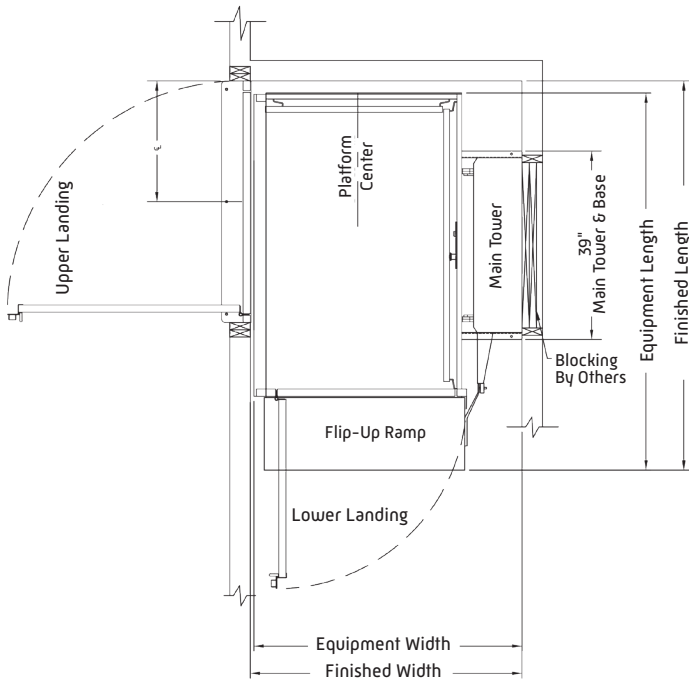

Unenclosed Design
90° With Flip-Up Ramp

Clear Platform {W" x L"}	Equipment Width	Equipment Length	Finished Width	Finished Length	Upper Gate C/L
42" x 60"	55¾"	78"	57"	80½"	25"

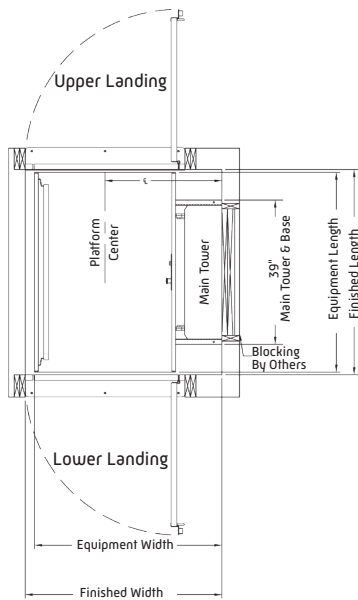

Shaftway Design Straight-Through

Clear Platform (W" x L")	Equipment Width	Equipment Length	Finished Width	Finished Length	Upper Gate C/L
36" x 48"	50¾"	48"	53¼"	49½"	31¾"
36" x 54"	50¾"	54"	53¼"	55½"	31¾"
36" x 60"	50¾"	60"	53¼"	61½"	31¾"
42" x 60"	56¾"	60"	59¼"	61½"	34¾"

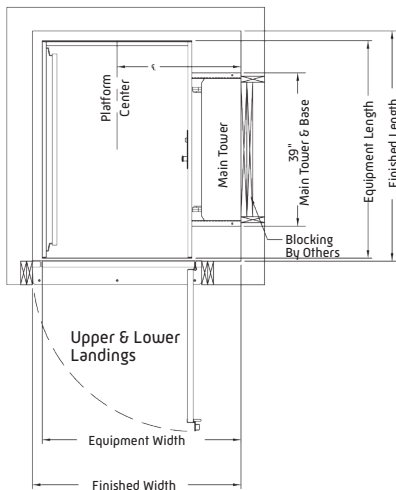

Shaftway Design Enter/Exit Same Side

Clear Platform (W" x L")	Equipment Width	Equipment Length	Finished Width	Finished Length	Gate C/L
36" x 48"	50¾"	49¼"	53¼"	52½"	31¾"
36" x 54"	50¾"	55¼"	53¼"	58½"	31¾"
36" x 60"	50¾"	61¼"	53¼"	64½"	31¾"
42" x 60"	54¾"	61¼"	59¼"	64½"	34¾"

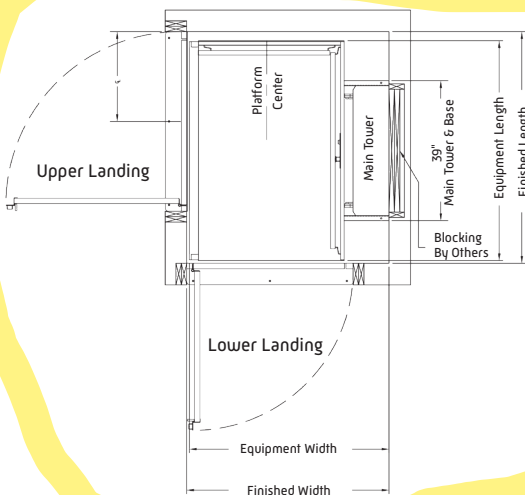

Shaftway Design 90°

Clear Platform (W" x L")	Equipment Width	Equipment Length	Finished Width	Finished Length	Upper Gate C/L	Lower Gate C/L
42" x 60"	55¾"	61¼"	57"	64½"	25"	33⅞"

Exit Configurations

Enclosure designs

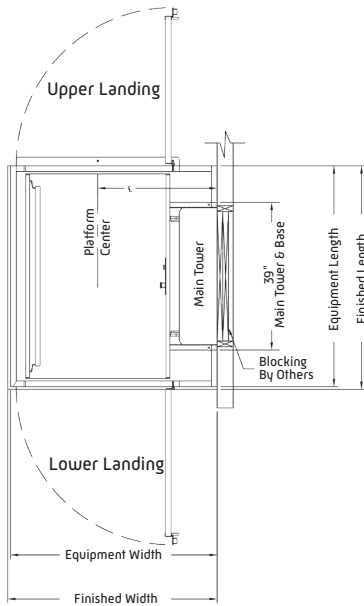

Enclosure Design Straight-Through

Clear Platform (W" x L")	Equipment Width	Equipment Length	Finished Width*	Finished Length*	Platform C/L
36" x 48"	54½"	52¼"	55½"	53¼"	31½"
36" x 54"	54½"	58¼"	55½"	59¼"	31½"
36" x 60"	54½"	64¼"	55½"	65¼"	31½"
42" x 60"	60½"	64¼"	61½"	65¼"	34½"

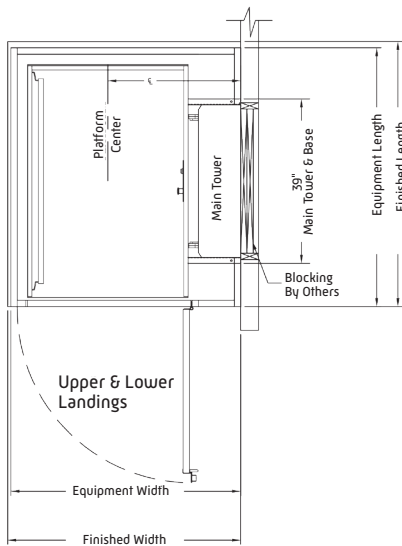

Enclosure Design Enter/Exit Same Side

Clear Platform (W" x L")	Equipment Width	Equipment Length	Finished Width*	Finished Length*	Platform C/L
36" x 48"	54½"	55⅜"	55½"	56⅜"	31½"
36" x 54"	54½"	61⅜"	55½"	62⅜"	31½"
36" x 60"	54½"	67⅜"	55½"	68⅜"	31½"
42" x 60"	60½"	67⅜"	61½"	68⅜"	34½"

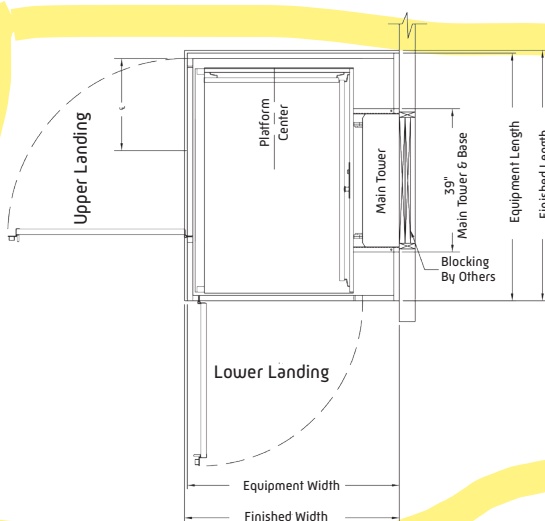

Enclosure Design 90°

Clear Platform (W" x L")	Equipment Width	Equipment Length	Finished Width*	Finished Length*	Platform C/L
42" x 60"	57⅝"	67⅜"	58⅝"	68⅜"	33¼"

* Recommended minimum pit dimension

Generic Static Loading Table for Vertical Platform Lifts Anchored to Floor and Wall

Symbol	Description	Value [Max]
F1=1090 lb.	Payload [Max]	750 lb.
	Car [Platform] Wt. Max	340 lb.
F2	Tower Weight	See Chart
F3	Floor Reaction [Inboard]	See Chart
F4	Floor Reaction [Outboard]	See Chart
F5	Wall Anchoring Reaction	See Chart
F6	Enclosure Weight*	See Chart
F7	Floor Shear Reaction	See Chart

Layout Geometry			
L1	L2**	L3	L4**
33.156	33.75	5.25	5.0

Model	Maximum Lifting Height	Tower Height	Approximate Anchor Height [L5]
42	45"	67"	43.88"
60	63"	85½"	61.68"
72	75"	97"	75.5"
96	99"	121"	101.44"
120	123"	145"	123.44"
144	147"	169"	147.7"
168	171"	193"	168.7"

Note: These are the reaction forces based on the gravity loads and operation of the lift. These calculations do not include external loading due to such things as wind, snow, rain, seismic activity, etc. Adhere to local building codes, regulations and safety factors for the supporting structures. Maximum lifting height will be decreased if a low profile platform is provided.

Static Equilibrium:

(Sum of forces and sum of moments = 0)

$$F1 + F2 = F3 + F4$$

$$F7 = F5$$

$$F5 * L5 + F4 * L2 + F3 * L4 = F2 * L3 + F1 * L1$$

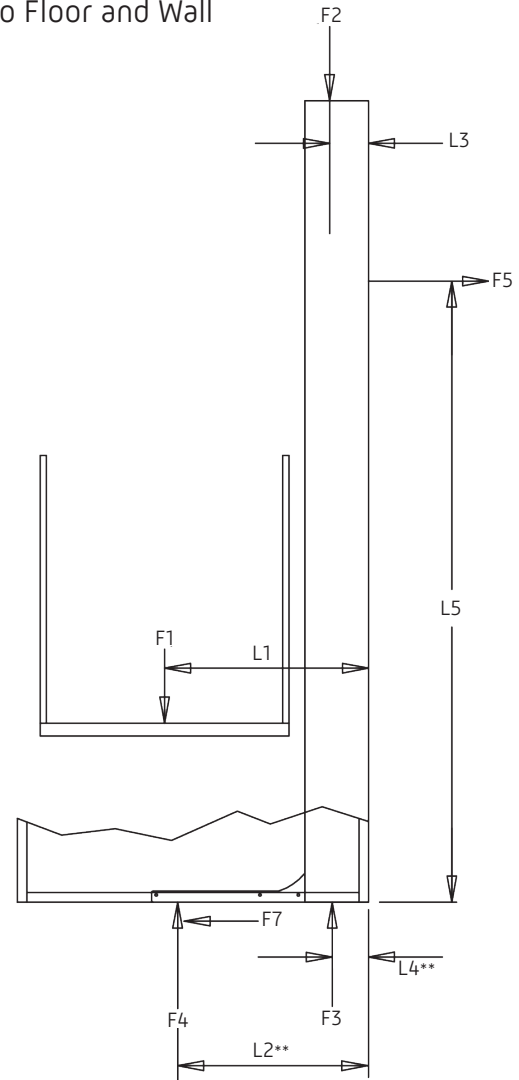

Values below are totals-divide by the number of bolts for individual bolt loads

Model	Max Tower lbs. F2	Inboard Floor Reaction lbs. F3**	Outboard Floor Reaction lbs. F4**	Wall Reaction lbs. F5**	Max Enclosure lbs. F6***		Floor Shear Reaction lbs. F7**
					Steel	Plexi	
42	446	1536	0	702	497	437	702
60	505	1595	0	500	573	498	500
72	544	1634	0	408	650	568	408
96	667	1757	0	304	765	666	304
120	743	1833	0	250	867	754	250
144	804	1894	0	209	978	848	209
168	899	1989	0	183	1079	935	183

* The enclosure weight is transferred directly to the floor along its perimeter through pads (two to a side) except for the back side where the wing walls bolt up directly to the tower.

** The reaction force values are based upon using an approximate horizontal mid-point location on the base as the single point of action for the floor reaction. In reality there is a load distribution across the base plate versus a single point load. This distribution will vary by unit size, platform size and position, etc. The assumption of a point load based on the centroid of a distributed load, however, does appear to provide reasonable results. We have chosen locations of the lines of action of reaction forces based upon the applicable geometry of the components and also based on multiple FEA structural analysis runs which provide support for those choices. We also assume the outboard floor bolt reaction forces go to zero, and this assumption provides a conservative approach and is supported by multiple FEA runs.

*** On enclosures, add 175 lbs. for a roof option and add 161 lbs. for a 6'8" or above option.

Pits and Ramps

Applications will be installed in one of the following manners.

Pit

For ease of use, a pit is the best option. A 3" depression in the slab is the typical pit application. This will allow for a smooth transition from the finished floor at the lowest landing to the platform surface of the vertical platform lift.

Stationary Ramp

In locations where a pit is not a feasible option, a stationary ramp may be utilized. The stationary ramp is located at the lowest landing and provides access to the lift platform by transitioning from the finished floor of the lowest landing to the platform surface of the vertical platform lift. A door/gate operator will be required.

Flip-Up Ramp

As an alternative to the pit and stationary ramp, a flip-up ramp can be used. The flip-up ramp is mounted to the edge of the platform on the side of the lift accessing the lowest landing. A flip-up ramp cannot be used in a shaftway or enclosure application, nor can it be mounted on the side of the lift that is opposite the main tower. When a flip-up ramp is used, the unit must also have a safety pan. In commercial application a platform gate and gate operator will be required.

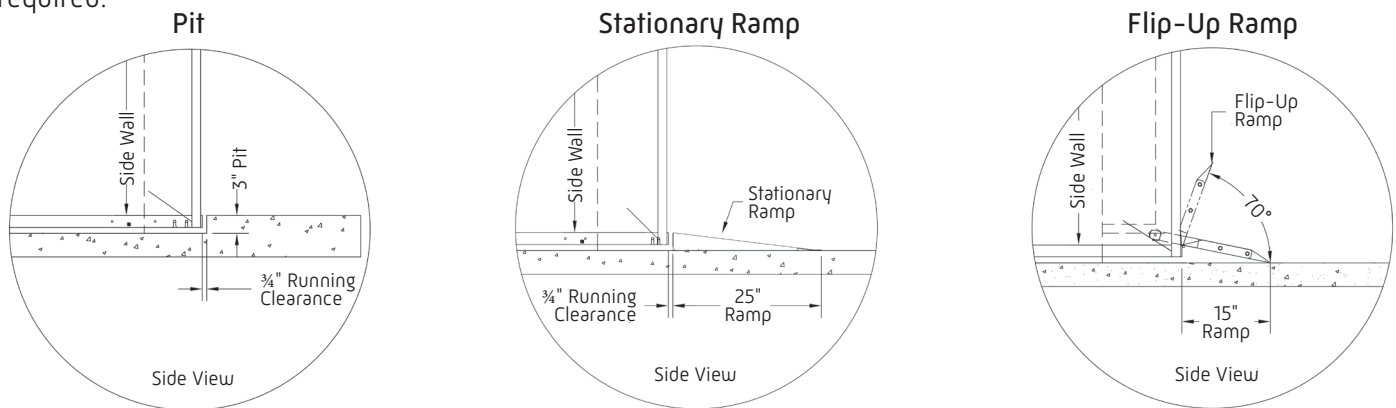

Door/Gate Swing

To determine a door or gate swing: With the door open, stand in the doorway with your back against the hinges, and move your arm in the direction of the open door. If you use your right arm, it is a right hand swing. If you use your left arm, it is a left hand swing.

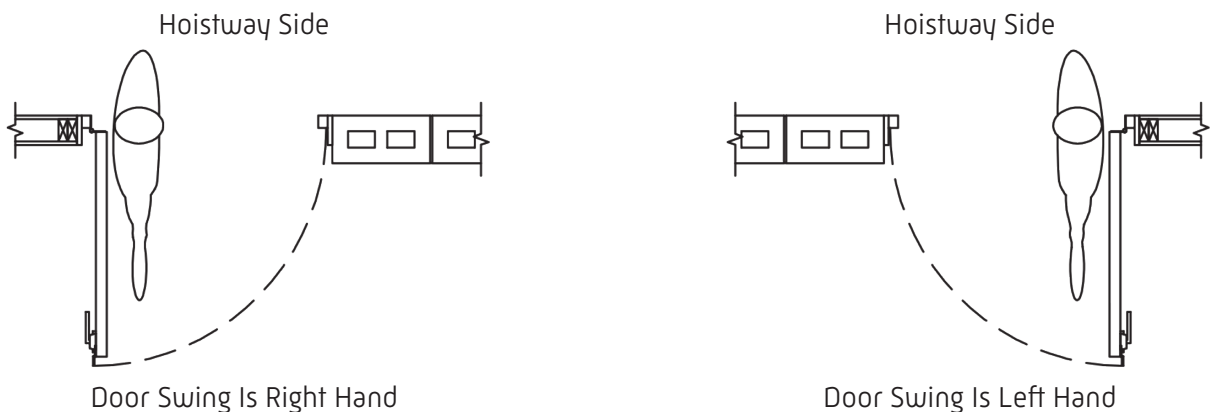

Note:

Call station operating locations must be clear of door swings

Upper landings are required to have a gate or door at a minimum of 42" tall for commercial applications and interlocked to the vertical platform lift.

In 90° or enter/exit same side applications, the upper landing gate is typically required to have an automatic gate/door operator. Gate and platform share a common centerline except for 90° or tower forward applications.

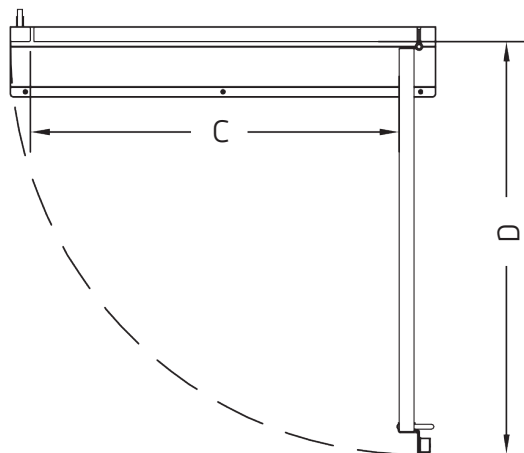
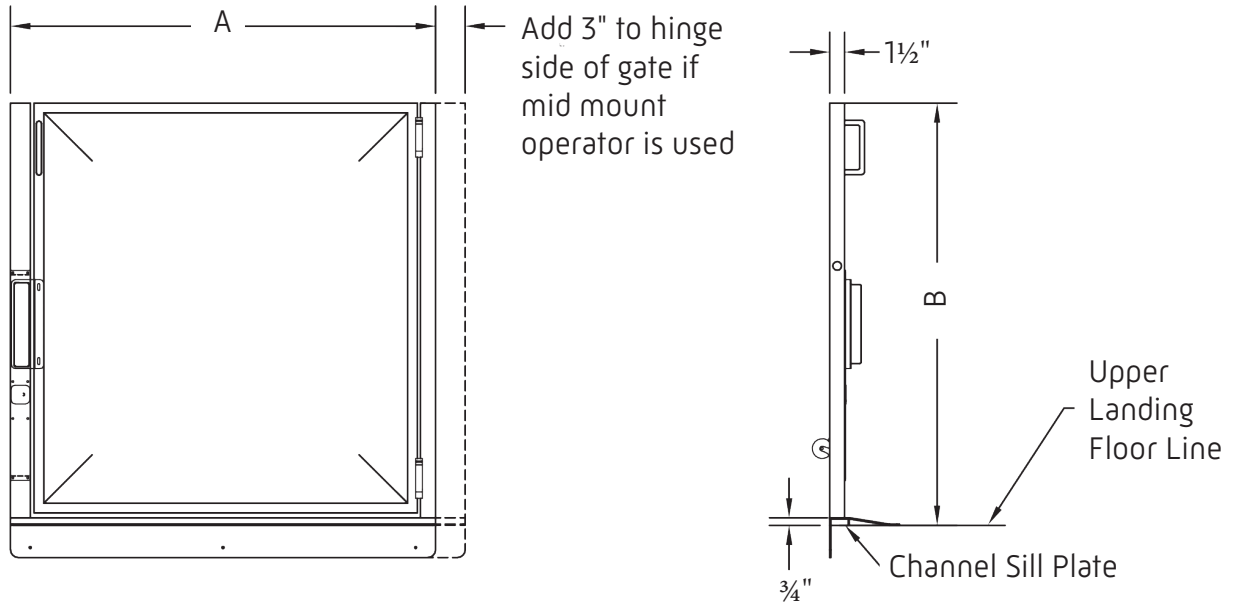

Gate Information			
Width A*	Height B	Clear Opening C	Projection D
43"	42 ³ / ₄ "	37 ⁵ / ₁₆ "	41 ³ / ₄ "
47"	42 ³ / ₄ "	41 ⁵ / ₁₆ "	45 ³ / ₄ "
48"	42 ³ / ₄ "	42 ⁵ / ₁₆ "	46 ³ / ₄ "

The gates listed in this chart are not self supporting

* Note: Add 3" width if gate has mid-mount operator

Gates

Lower landing gate

Lower landings are required to have either a platform gate, lower landing gate or door interlocked to the vertical platform lift.

The interlock prevents the gate/door from being opened when the platform is not at the landing and prevents the vertical platform lift from moving away from a landing if the gate/door is not closed and locked.

In 90° or enter/exit same side applications, the lower landing gate is typically required to have an automatic gate/door operator. In unenclosed applications, a platform gate is not available on the wide side of the platform.

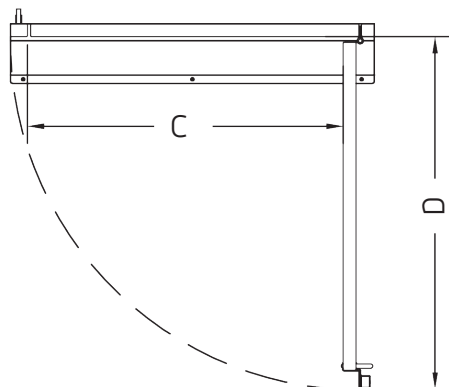
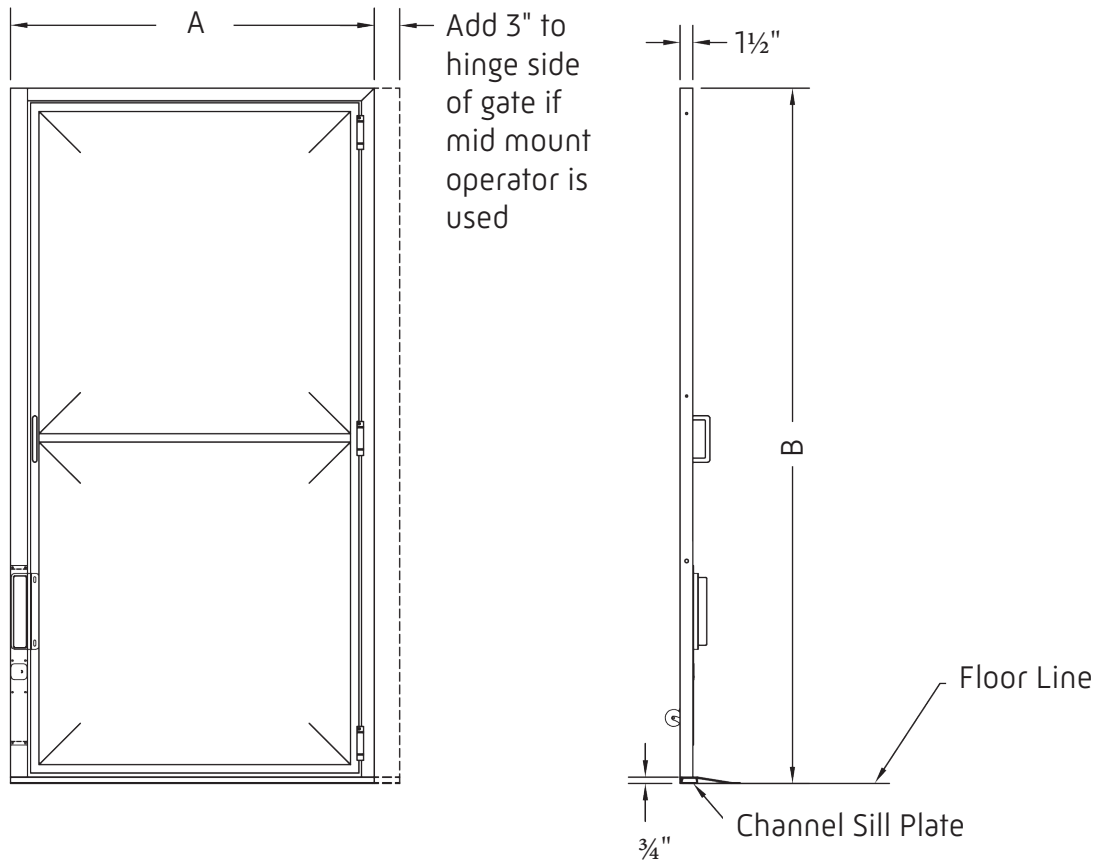

Gate Information			
Width A*	Height B	Clear Opening C	Projection D
43"	82 1/4"	37 5/16"	41 3/4"
47"	82 1/4"	41 5/16"	45 3/4"
48"	82 1/4"	42 5/16"	46 3/4"
The gates listed in this chart are not self supporting			

* Note: Add 3" width if gate has mid-mount operator

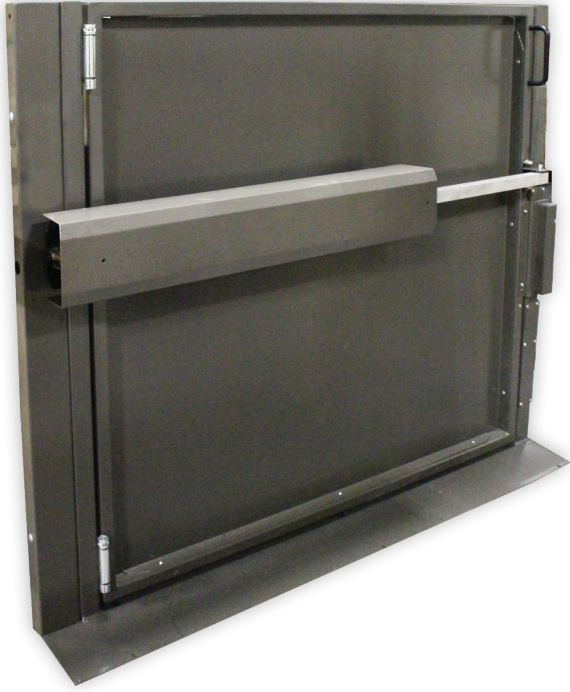

Standard Features

- Low profile "Smart Operation"*
- 2 speed operation
- Automatic reset upon contact with an obstruction
- Opening/Closing Time: Approximately 8 seconds
- Adjustable hold open time
- Battery backup standard with commercial applications
- Capable of manual operation

Optional Features

- Battery backup for residential applications

* Allows operator to open, stop at obstruction, close and remain in normal operation mode.



Power Door Operator



Standard Features

- Indoor and outdoor use with cover
- Low energy operator
- Opening/Closing Time: Approximately 8 seconds
- Adjustable hold open time
- Capable of manual operation



Power door operator with rain cover

Flush Door and/or Frame



Flush Door shown in Red Oak

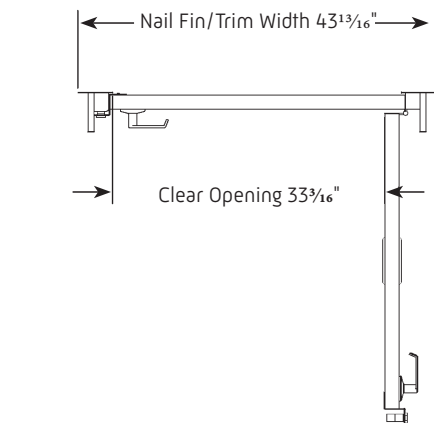
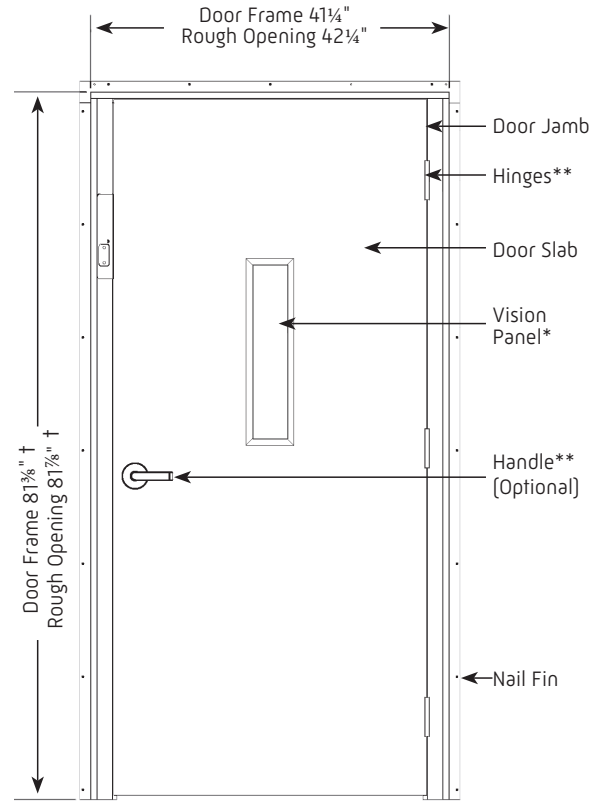
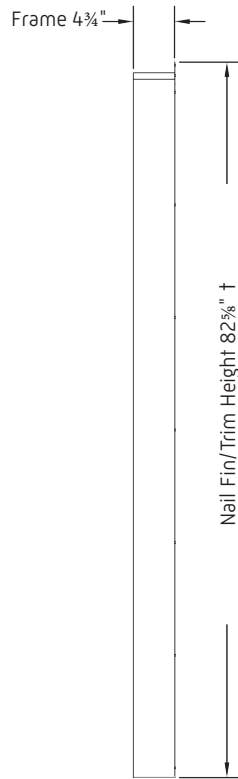

Notes:

- 1) LH shown RH opposite
- 2) The door/frame is suitable for installation in masonry or wood frame construction
- 3) The door/frame is installed with the door flush to the inside of the hoistway
- 4) Distance between the door sill and the platform must be between $\frac{3}{8}$ " - $\frac{3}{4}$ "
- 5) The interior hoistway wall should be finished up to the rough opening
- 6) This can be furnished as a frame only or complete door with frame
- 7) Delay action door closer or power door operator required for code compliance
- 8) Indoor use only, non fire-rated
- 9) Standard Red Oak, other species available

* Vision panel provided only with complete door package

** Handle and hinges optional with frame, but included with complete door package

† Dimensions increase by $1\frac{1}{8}$ " when delay action door closer is used

1½ Hour Fire-Rated Flush Door (B Label)

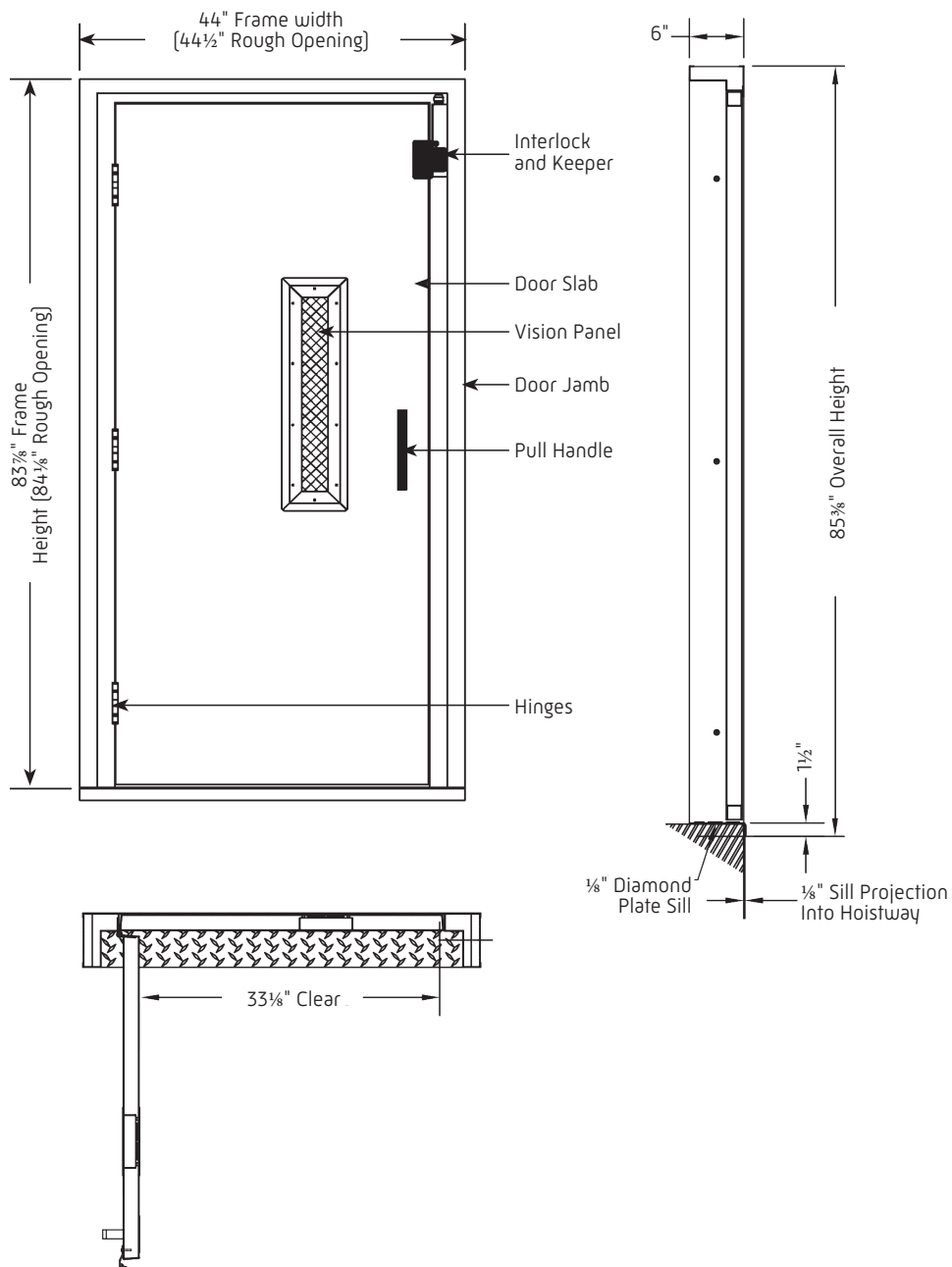

Notes:

- 1) RH shown LH opposite
- 2) Door suitable for installation masonry or wood frame construction
- 3) Install door frame body flush with the inside of the hoistway
- 4) Distance between the door sill and the platform must be between ⅜" - ¾"
- 5) Delay action door closer or power door operator required for code compliance
- 6) For wood frame construction, drywall is to be finished up to the door frame

Typical Conduit Layout

Consult with the elevator/accessibility contractor prior to hoistway construction to coordinate the location of electrical boxes.

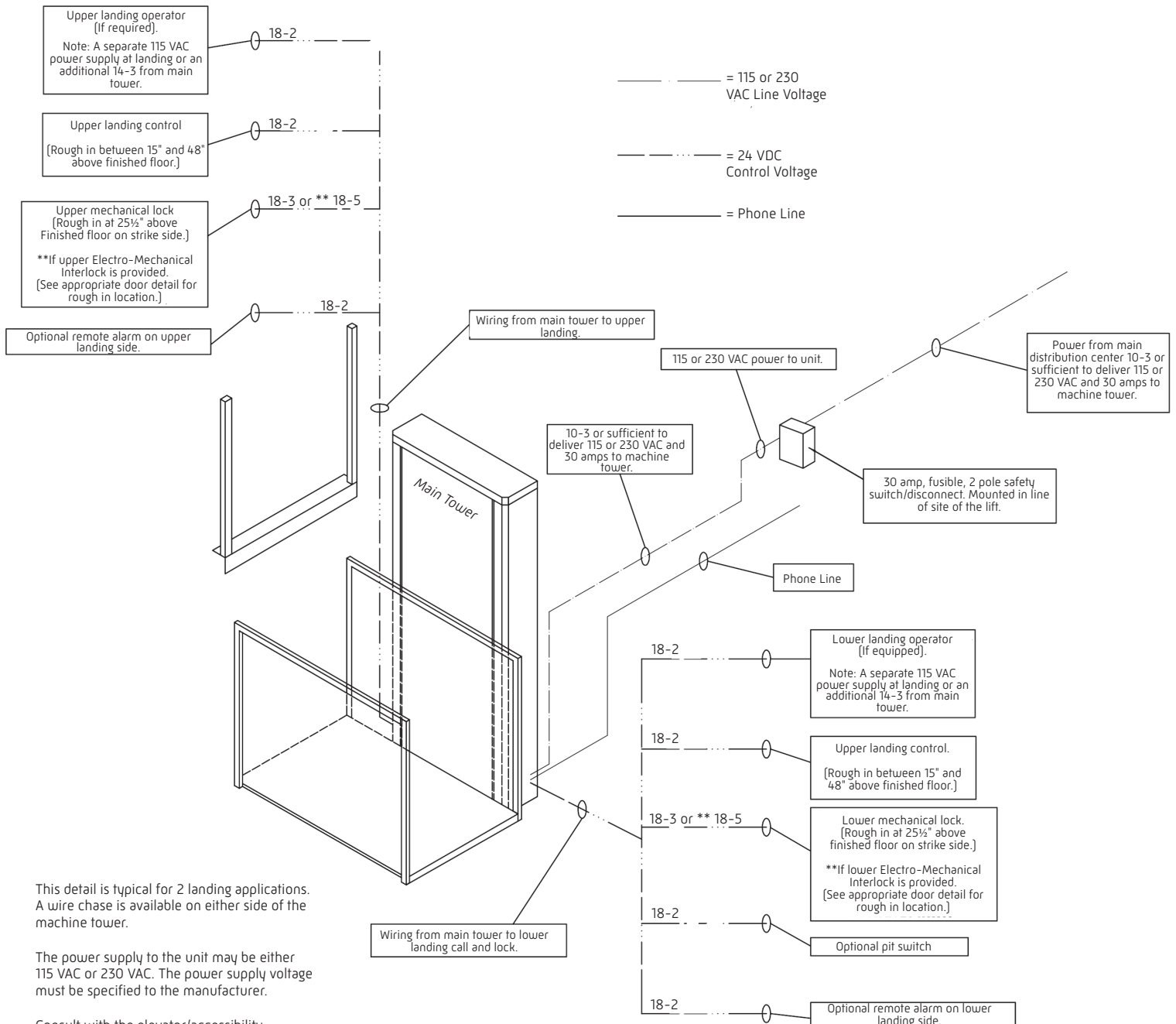

This detail is typical for 2 landing applications. A wire chase is available on either side of the machine tower.

The power supply to the unit may be either 115 VAC or 230 VAC. The power supply voltage must be specified to the manufacturer.

Consult with the elevator/accessibility contractor prior to hoistway construction to coordinate the location of electrical boxes.

Please note that this guide is for planning purposes only, applies exclusively to national code, and should not be used for construction. Prior to construction, please contact your local Symmetry Elevating Solutions representative and request a job-specific set of plans to ensure that you obtain the accurate dimensions and requirements for your project.

Your representative will also assist you to identify resources to ensure that your project plans will comply with the applicable state and local codes and the permitting authorities.





symmetry

eLEVATING SOLUTIONS

PART OF CIBES LIFT GROUP



AIA Continuing Education

symmetryelevator.com/aia

Symmetry offers an in-person course to obtain continuing education credits. Each completed course is worth 1 (one) LU|HSW credit and provides a detailed review of residential elevators, vertical platform lifts (VPL) and limited use/limited application (LULA) elevators.

The course also addresses: code application, specification, suitability of product type, the direct governance guidelines of ADA, ANSI and ASME, and site conditions required for a successful final installation.