



DEPARTMENT OF REGULATORY AND ECONOMIC RESOURCES (RER)
BOARD AND CODE ADMINISTRATION DIVISION

NOTICE OF ACCEPTANCE (NOA)

MIAMI-DADE COUNTY
PRODUCT CONTROL SECTION
11805 SW 26 Street, Room 208
Miami, Florida 33175-2474
T (786) 315-2590 F (786) 315-2599
www.miamidade.gov/economy

AWP Window & Door Solutions, LLC
8130 NW 74th Avenue
Medley, FL 33166

SCOPE:

This NOA is being issued under the applicable rules and regulations governing the use of construction materials. The documentation submitted has been reviewed and accepted by Miami-Dade County RER -Product Control Section to be used in Miami Dade County and other areas where allowed by the Authority Having Jurisdiction (AHJ).

This NOA shall not be valid after the expiration date stated below. The Miami-Dade County Product Control Section (In Miami Dade County) and/or the AHJ (in areas other than Miami Dade County) reserve the right to have this product or material tested for quality assurance purposes. If this product or material fails to perform in the accepted manner, the manufacturer will incur the expense of such testing and the AHJ may immediately revoke, modify, or suspend the use of such product or material within their jurisdiction. RER reserves the right to revoke this acceptance, if it is determined by Miami-Dade County Product Control Section that this product or material fails to meet the requirements of the applicable building code.

This product is approved as described herein, and has been designed to comply with the Florida Building Code, including the High Velocity Hurricane Zone.

DESCRIPTION: Series "4100" Aluminum Sliding Glass Door (Steel-reinforced)-L.M.I.

APPROVAL DOCUMENT: Drawing No. W09-17 Rev G, titled "Series 4100 Alum Sld. Glass Door (L.M.I.)", sheets 1 through 6 of 6, dated 03-11-09 and last revised on May 06, 2015, prepared by AL-Farooq Corporation, signed and sealed by Javad Ahmad, P.E., bearing the Miami-Dade County Product Control Revision stamp with the Notice of Acceptance number and expiration date by the Miami-Dade County Product Control Section.

MISSILE IMPACT RATING: Large Missile Impact Resistant

Limitations:

- 1. OX, XO or OXO configurations.
- 2. Typical pairs of anchors to be used at each location shown in elevation in sheet 1.

LABELING: Each unit shall bear a permanent label with the manufacturer's name or logo, city, state and series and following statement: "Miami-Dade County Product Control Approved", noted herein.

RENEWAL of this NOA shall be considered after a renewal application has been filed and there has been no change in the applicable building code negatively affecting the performance of this product.

TERMINATION of this NOA will occur after the expiration date or if there has been a revision or change in the materials, use, and/or manufacture of the product or process. Misuse of this NOA as an endorsement of any product, for sales, advertising or any other purposes shall automatically terminate this NOA. Failure to comply with any section of this NOA shall be cause for termination and removal of NOA.

ADVERTISEMENT: The NOA number preceded by the words Miami-Dade County, Florida, and followed by the expiration date may be displayed in advertising literature. If any portion of the NOA is displayed, then it shall be done in its entirety.

INSPECTION: A copy of this entire NOA shall be provided to the user by the manufacturer or its distributors and shall be available for inspection at the job site at the request of the Building Official.

This NOA revises & renews #13-1224.01 (former Trulite Windows & Doors, LLC) consists of this page 1 and evidence pages E-1 & E-2, as well as approval document mentioned above.

The submitted documentation was reviewed by Ishaq I. Chanda, P.E.



NOA No. 14-1103.02
Expiration Date: July 08, 2019
Approval Date: May 13, 2015
Page 1

5/13/15

NOTICE OF ACCEPTANCE: EVIDENCE SUBMITTED

A. DRAWINGS

1. Manufacturer's die drawings and sections(Submitted under files see below)
2. Drawing No. **W09-17 Rev G**, titled "Series 4100 Alum Sld. Glass Door (L.M.I.)", sheets 1 through 6 of 6, dated 03-11-09 and last revised on May 06, 2015, prepared by AL-Farooq Corporation, signed and sealed by Javad Ahmad, P.E.

B. TESTS (Submitted under file #13-1224.01/#12-0118.31 & #10-0804.04)

1. Test reports on:
 - 1) Air Infiltration Test, per FBC, TAS 202-94
 - 2) Uniform Static Air Pressure Test, Loading per FBC TAS 202-94
 - 3) Water Resistance Test, per FBC, TAS 202-94
 - 4) Large Missile Impact Test per FBC, TAS 201-94
 - 5) Cyclic Wind Pressure Loading per FBC, TAS 203-94
 - 6) Forced Entry Test, per FBC 2411 3.2.1, TAS 202-94

Along with marked-up drawings and installation diagram of an OXO aluminum Sliding glass door, prepared by Fenestration Testing Lab., Test Report No. **FTL-5766**, dated 01/23/09, signed and sealed by Michael S. Wenzel, P. E.

C. CALCULATIONS (submitted under file #13-1224.01)

1. Anchor verification calculations and structural analysis, complying with FBC-2014 (5th Edition), prepared by Al Farooq Corporation, dated 03/31/14 and last revised on 06/04/14, signed and sealed by Javad Ahmad, P.E.
2. Glazing complies w/ ASTM E-1300-04 &-09

D. QUALITY ASSURANCE

1. Miami Dade Department of Regulatory and Economic Resources (RER).

E. MATERIAL CERTIFICATIONS

1. Notice of Acceptance No. **12-1231.08** issued to **Eastman Chemical Company (MA)** for the "Saflex CP: Saflex and Saflex HP Composite Glass Interlayers with PET Core", expiring on 12/11/18.
2. Technical strength data of flexible vinyl (Apex 31674) gasket extruded by Melt plastic Int'l Inc.

F. STATEMENTS

1. Statement letter for Name change Request dated July 15, 2014, issued by AWP, LLC, signed by Gerardo Beros, director of Engineering.
2. Statement Letter from Trulite Window & Door Solutions, LLC, owners of existing NOA, stating that they have sold all assets to the applicant, that they no longer manufacture the product and relinquish their rights to the current NOA (notarized Schedule A), dated April 20, 2015, signed by Mr. Kevin Barrett, Chief Financial Officer.
3. Asset purchase agreement dated March 20, 2014, between Trulite Intermediate Holding, Inc.(Asset Sellers) and AWP Windows and Doors, LLC (Acquiror) signed by Mr. Paul Schmitz, Chief Executive Officer and President, Trulite Intermediate Holding, LLC and Mr. Tim Morris, Jr., President and C.F.O., AWP Windows and Doors, LLC
4. Statement letter of conformance to FBC 2014 (**5th Edition**), prepared by Al-Farooq Corporation, dated 01/04/12, signed and sealed by Javad Ahmad, P.E.(submitted under file #13-1224.01).



Ishaq I. Chanda, P.E.

Product Control Examiner
NOA No. 14-1103.02

Expiration Date: July 08, 2019
Approval Date: May 14, 2015

NOTICE OF ACCEPTANCE: EVIDENCE SUBMITTED

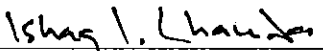
- F. **STATEMENTS** (continue) : (Statement below were submitted under files #13-1224.01(Truelite) #12-0118.31 & #10-0804.04)
5. Statement letter of conformance FBC 2010 and letter of no financial interest, prepared by Al-Farooq Corporation, dated 01/04/12, signed and sealed by Javad Ahmad, P.E. (Submitted under file #12-0118.31)
 6. Statement letter of compliance, part of the above referenced test reports
 7. Sales agreement between AWP, LLC (seller) and Arch Aluminum & Glass Enterprise, a Delaware Corp (purchaser) dated Jan 14, 2010, signed by Leon J. Silverstein and Wm, Robert Wright, respectively.
 8. Certificate of registration of Arch Windows, LLC in State of Delaware, dated 02-03-10.
 9. Certificate of registration of Arch Windows, LLC (Delaware) in State of Florida dated 02-04, 2010, managed by Arch Intermediate Holding, LLC.
 10. Florida Dept. of State, listing of Arch Window, LLC (Foreign Limited Liability Co.), managed by Arch Intermediate Holding, LLC, Tamarac, Fl.
 11. Asset purchase agreement dated 11/01/06 among AWP, LLC (Buyer) and Yale Ogron Windows & Door Inc. (seller), signed by Leon J. Silverstein and Manny Valladares, respectively.
 12. Statement letter dated March 25, 2010, issued by Arch Windows, LLC that it has purchased all assets of AWP, LLC effectively Jan 29, 2010, signed by Leon Silverstein, President/CEO (Arch Windows, LLC).
- G. **OTHER**
1. This NOA revises #13-1224.01(former Trulite Windows & Doors), expiring on July 08, 2019.
 2. Test proposal dated 08/04/08 approved by BCCO.



Ishaq I. Chanda, P.E.
Product Control Examiner
NOA No. 14-1103.02
Expiration Date: July 08, 2019
Approval Date: May 14, 2015

DESIGN LOAD CAPACITY - PSF				
DOOR FRAME WIDTH (OX, XO) INCHES	DOOR FRAME WIDTH (OXO) INCHES	DOOR FRAME HEIGHT INCHES	7/16" LAM. GLASS	
			EXT. (+)	INT. (-)
72	108	82	60.0	60.0
80	120		60.0	60.0
88	132		60.0	60.0
96	144		60.0	60.0
104	156		55.6	55.6
112	168		51.6	51.6
72	108	84	60.0	60.0
80	120		60.0	60.0
88	132		60.0	60.0
96	144		60.0	60.0
104	156		55.6	55.6
72	108	90	60.0	60.0
80	120		60.0	60.0
88	132		60.0	60.0
96	144		60.0	60.0
72	108	95-1/2	60.0	60.0
80	120		60.0	60.0
88	132		60.0	60.0
96	144		60.0	60.0

DOOR HEIGHT AND WIDTH SIZE MUST COMPLY EGRESS REQUIREMENTS PER FBC.

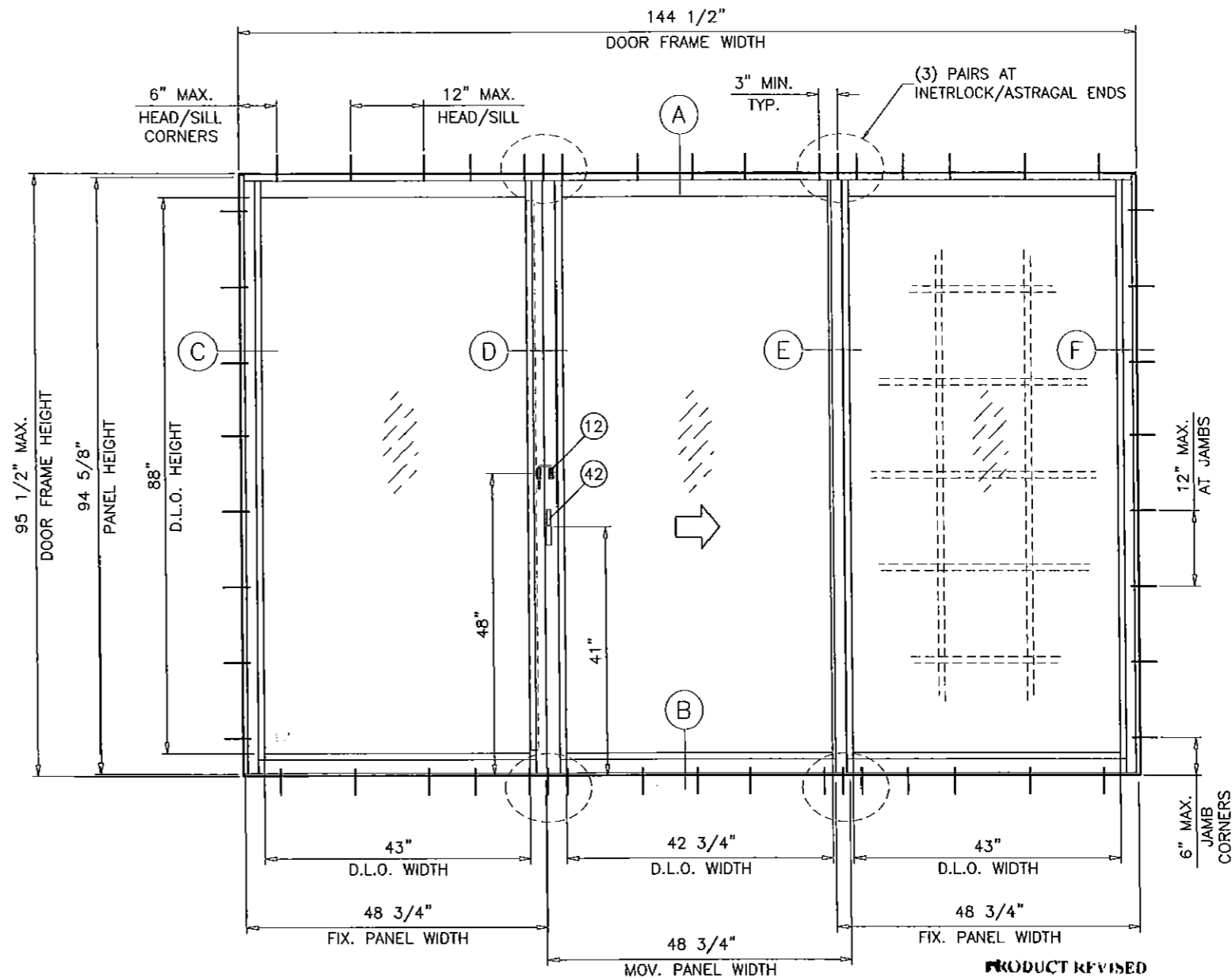
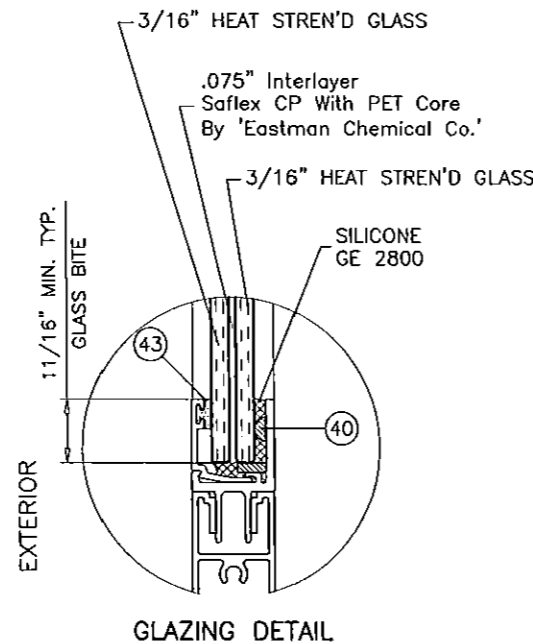

TYPICAL ELEVATION
TESTED UNITS

PRODUCT REVISED
as complying with the Florida
Building Code
Acceptance No. 14-1103-02
Expiration Date JULY 06 2019
By *Shahid I. Chaudhry*
Miami Dade Product Control

DAYLITE OPENINGS:

- D.L.O. HEIGHT = PANEL HEIGHT - 6.625"
- D.L.O. WIDTH (FIX. PANEL) = PANEL WIDTH - 5.750"
- D.L.O. WIDTH (OPER. PANEL) = PANEL WIDTH - 6.000"
- PANEL HEIGHT = DOOR FRAME HEIGHT - 0.875"

SERIES 4100 ALUMINUM SLIDING GLASS DOOR

DESIGN LOAD CAPACITY FOR DOORS TO BE AS PER CHARTS SHOWN ABOVE.

THIS PRODUCT HAS BEEN DESIGNED AND TESTED TO COMPLY WITH THE REQUIREMENTS OF THE FLORIDA BUILDING CODE INCLUDING HIGH VELOCITY HURRICANE ZONE (HVHZ).

1BY OR 2BY WOOD BUCKS BY OTHERS, MUST BE ANCHORED PROPERLY TO TRANSFER LOADS TO THE STRUCTURE.

ANCHORS SHALL BE AS LISTED, SPACED AS SHOWN ON DETAILS, ANCHORS EMBEDMENT TO BASE MATERIAL SHALL BE BEYOND WALL DRESSING OR STUCCO.

ANCHORING OR LOADING CONDITIONS NOT SHOWN IN THESE DETAILS ARE NOT PART OF THIS APPROVAL.

A LOAD DURATION INCREASE IS USED IN DESIGN OF ANCHORS INTO WOOD ONLY.

MATERIALS INCLUDING BUT NOT LIMITED TO STEEL/METAL SCREWS, THAT COME INTO CONTACT WITH OTHER DISSIMILAR MATERIALS SHALL MEET THE REQUIREMENTS OF THE FLORIDA BLDG. CODE.

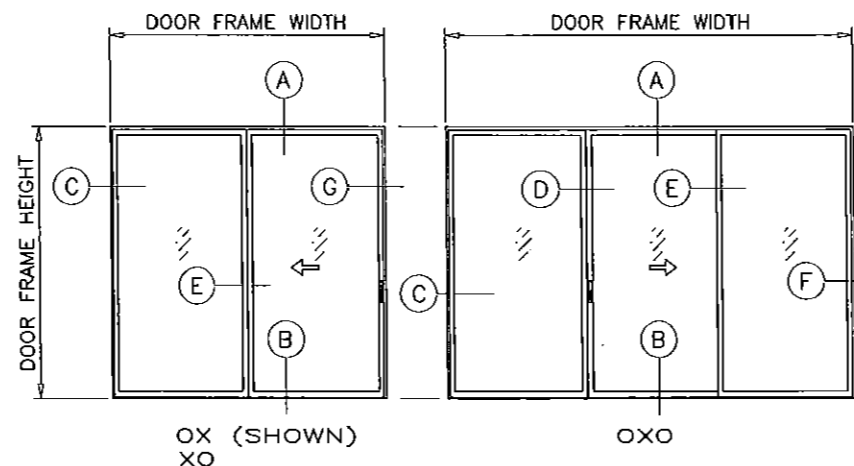

APPROVED CONFIGURATIONS

NOTE:
GLASS CAPACITIES ON THIS SHEET ARE BASED ON ASTM E1300-09 (3 SEC. GUSTS) AND FLORIDA BUILDING COMMISSION DECLARATORY STATEMENT DCA05-DEC-219

THESE DOORS ARE RATED FOR LARGE & SMALL MISSILE IMPACT AND REQUIRE NO SHUTTERS.

Engr: JAVAD AHMAD
CIVIL
FLA. PE # 70592
C.A.N. 3538
MAY 06 2015

af c
AL-FAROOQ CORPORATION
ENGINEERS & PRODUCT DEVELOPMENT
1235 S.W. 87 AVE
MIAMI, FLORIDA 33174
TEL. (305) 264-8100 FAX. (305) 262-6978
COMP-ANL\W09-17AWP

SERIES 4100 ALUM. SLID. GLASS DOOR (L.M.I.)
AWP WINDOWS AND DOORS, LLC
8130 N.W. 74TH AVE.
MEDLEY, FL. 33166
TEL. (305) 887-2646 FAX (305) 883-1309

no	date	description	by
D	12.23.11	UPDATED TO 2010 FBC, NAME REV	
E	03.12.14	REV. PER PER COMMENTS	
F	05.27.14	REV. PER PER COMMENTS	
G	06.25.14	MANUF. NAME REV.	

date: 03-11-09
scale: 1/2"=1'-0"
dr. by: HAMID
chk. by:

drawing no.
W09-17
sheet 1 of 6

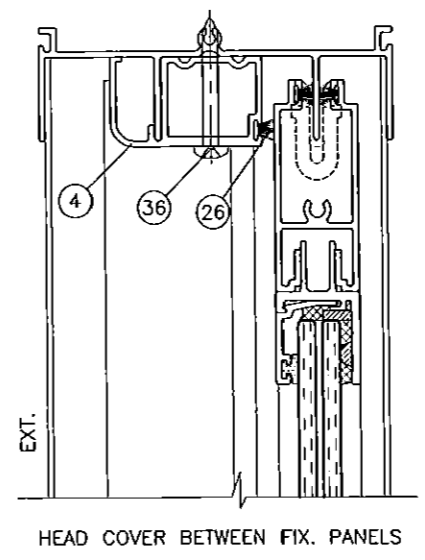
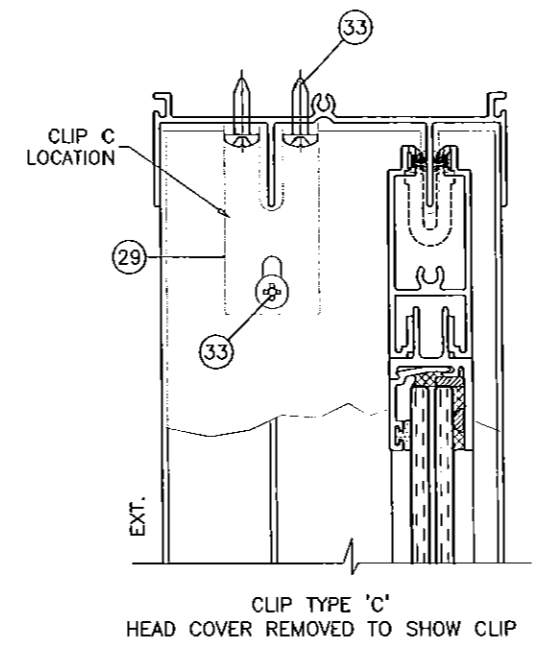
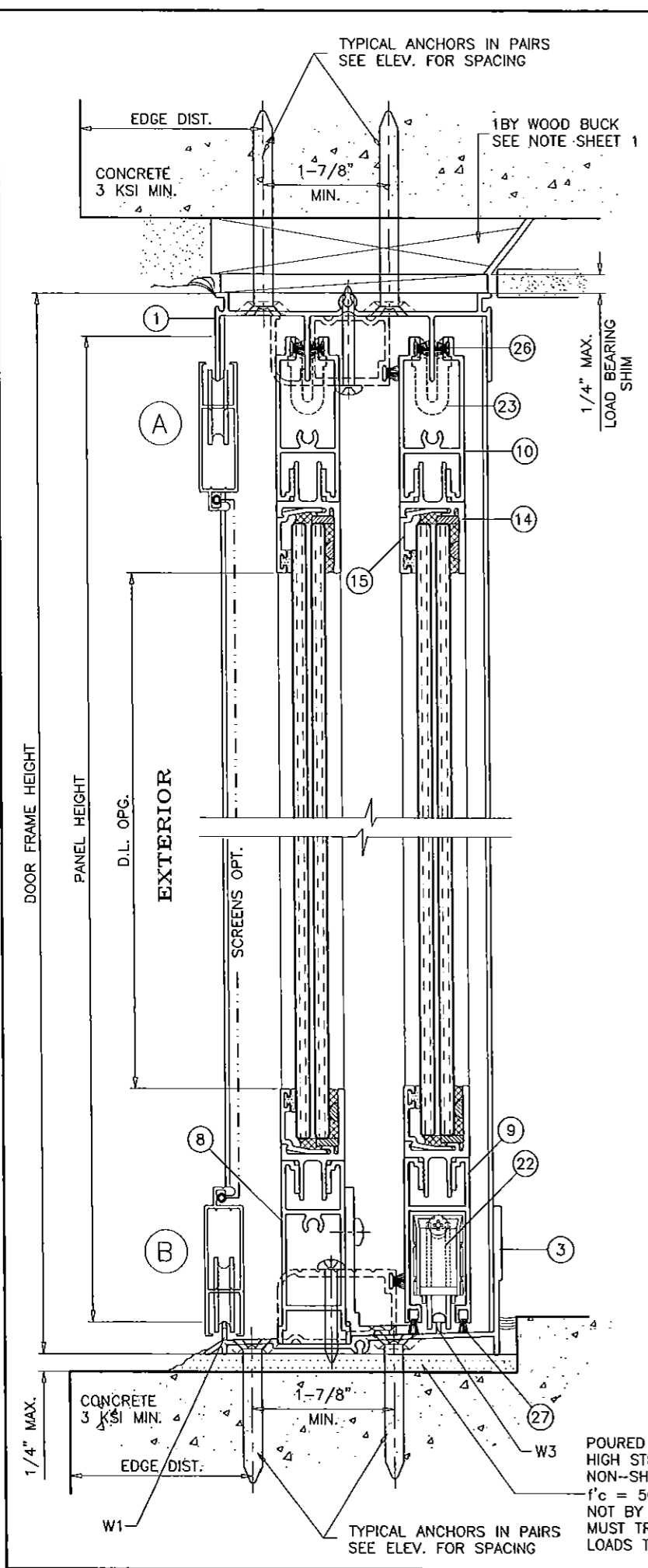

FIXED PANEL CLIPS INSTALLATION SHOWN IN DETAILS
FOR DOOR FASTENERS SEE SHEETS 2 THRU 4.

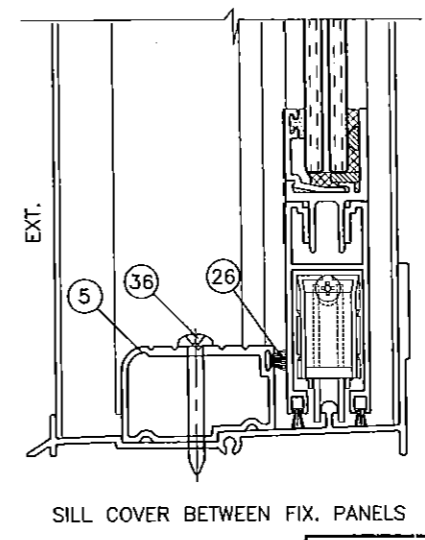
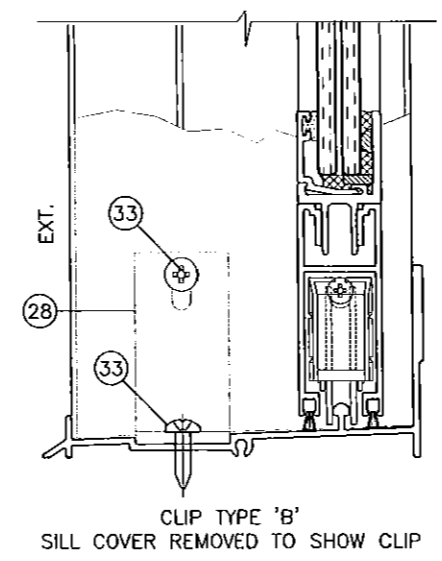
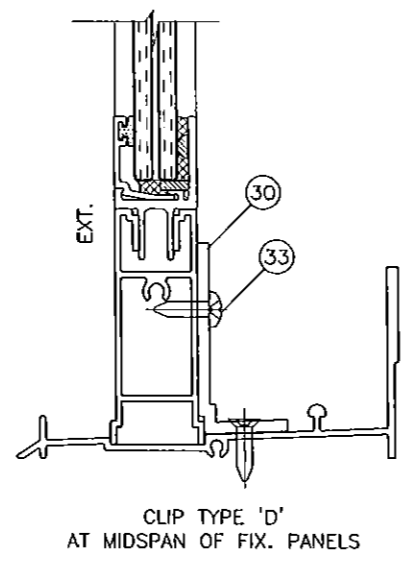

PRODUCT REVISED
to comply with the Florida
Building Code
Acceptance No 14-1103-02
Expiration Date 7/8/19
By *Uthman Al-Hamad*
Uthman Al-Hamad Product Control

Engr: JAVAD AHMAD
CIVIL
FLA. PE # 70592
C.A.N. 3538
[Signature]
MAY 06 2015

af c
AL-FAROOQ CORPORATION
ENGINEERS & PRODUCT DEVELOPMENT
1235 S.W. 87 AVE
MIAMI, FLORIDA 33174
TEL. (305) 264-8100 FAX. (305) 262-6978
COMP-ANL\W09-17AWP

SERIES 4100 ALUM SLD. GLASS DOOR (L.M.I.)
AWP WINDOWS AND DOORS, LLC
8130 N.W. 74TH AVE.
MEDLEY, FL. 33166
TEL. (305) 887-2646 FAX (305) 883-1309

no	date	by	description
D	12.23.11	MANUF. NAME REVISED	
E	03.12.14	REV. PER PER COMMENTS	
F	05.27.14	NO CHANGE THIS SHEET	
G	06.25.14	MANUF. NAME REV.	

date: 03-11-09
scale: 1/2" = 1"
dr. by: HAMID
chk. by:

drawing no.
W09-17
sheet 2 of 6

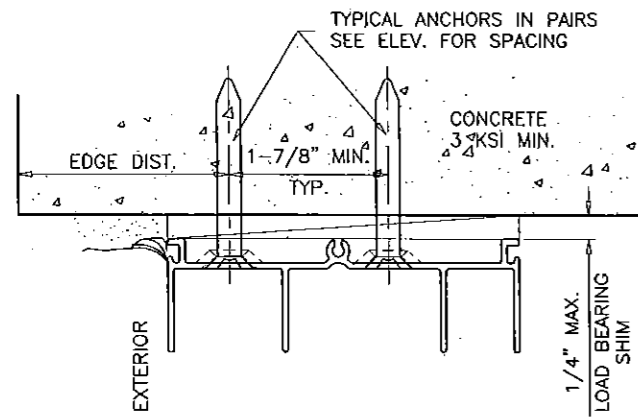

TYPICAL ANCHORS IN PAIRS
SEE ELEV. FOR SPACING

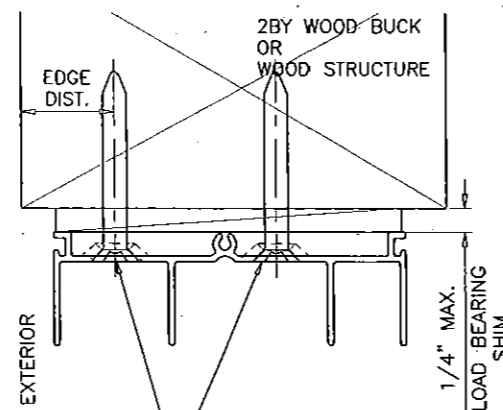

TYPICAL ANCHORS IN PAIRS
SEE ELEV. FOR SPACING

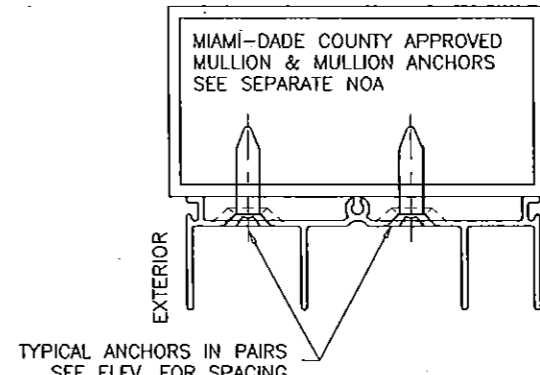
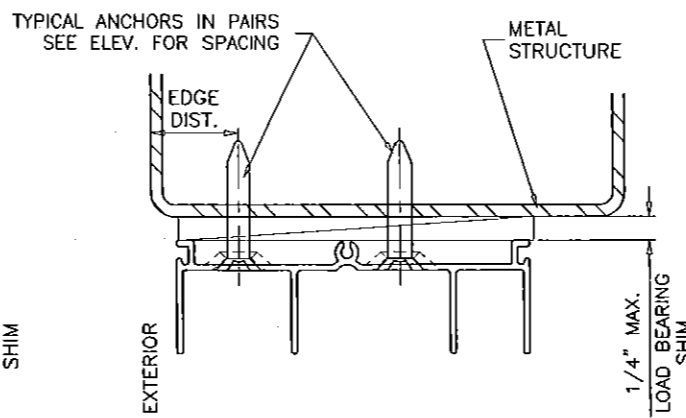

TYPICAL ANCHORS IN PAIRS
SEE ELEV. FOR SPACING

WOOD BUCKS AND METAL STRUCTURE NOT BY AWP WINDOWS
MUST SUSTAIN LOADS IMPOSED BY GLAZING SYSTEM
AND TRANSFER THEM TO THE BUILDING STRUCTURE.

TYPICAL ANCHORS: SEE ELEV. FOR SPACING

1/4" DIA. TAPCON BY 'ITW' (Fu=120 KSI, Fy=92 KSI)

1/4" DIA. ULTRACON BY 'ELCO' (Fu=177 KSI, Fy=155 KSI)

INTO 2BY WOOD BUCKS OR WOOD STRUCTURES
1-1/2" MIN. PENETRATION INTO WOOD

THRU 1BY BUCKS INTO CONC. OR MASONRY
1-1/4" MIN. EMBED INTO CONCRETE (HEAD/SILL)
1-1/4" MIN. EMBED INTO CONC. OR MASONRY (JAMBS)

DIRECTLY INTO CONC. OR MASONRY
1-3/4" MIN. EMBED INTO CONCRETE (HEAD/SILL)
1-1/4" MIN. EMBED INTO CONC. OR MASONRY (JAMBS)

1/4" DIA. TEKS OR SELF DRILLING SCREWS (GRADE 5 CRS)

INTO METAL STRUCTURES
STEEL : 12 GA. MIN. (Fy = 36 KSI MIN.)
ALUMINUM : 1/8" THK. MIN. (6063-T5 MIN.)
(STEEL IN CONTACT WITH ALUMINUM TO BE PLATED OR PAINTED)

1/4" DIA. TEKS OR SELF DRILLING SCREWS (GRADE 5 CRS)

INTO MIAMI-DADE COUNTY APPROVED MULLIONS (MIN. THK. = 1/8")
(NO SHIM SPACE)

TYPICAL EDGE DISTANCE

INTO CONCRETE AND MASONRY = 2-1/2" MIN.
INTO WOOD STRUCTURE = 1" MIN.
INTO METAL STRUCTURE = 1/2" MIN.

CONCRETE AT HEAD, SILL OR JAMBS f'c = 3000 PSI MIN.
C-90 HOLLOW/FILLED BLOCK AT JAMBS f'm = 2000 PSI MIN.

Engr: JAVAD AHMAD
CIVIL
FLA. PE # 70592
C.A.N. 3538

MAY 06 2015

PRODUCT REVISED
as complying with the Florida
Building Code
Acceptance No. 14-1103.02
Expiration Date 7/8/19
By: *Shay L. Chant*
Miami Dade Product Council

af c

AL-FAROOQ CORPORATION
ENGINEERS & PRODUCT DEVELOPMENT
1235 S.W. 87 AVE
MIAMI, FLORIDA 33174
TEL (305) 264-8100 FAX (305) 262-6978
COMP-ANL W09-17AWP

SERIES 4100 ALUM SLD. GLASS DOOR (L.M.I.)

AWP WINDOWS AND DOORS, LLC
8130 N.W. 74TH AVE.
MEDLEY, FL. 33166
TEL. (305) 887-2646 FAX (305) 863-1309

no	date	description	by
D	12.23.11	MANUF. NAME REVISED	
E	03.12.14	REV. PER PER COMMENTS	
F	05.27.14	REV. PER PER COMMENTS	
G	06.25.14	MANUF. NAME REV.	

date: 03-11-09
scale: 1/2" = 1"
dr. by: HAMID
chk. by:

drawing no.
W09-17

sheet 3 of 6

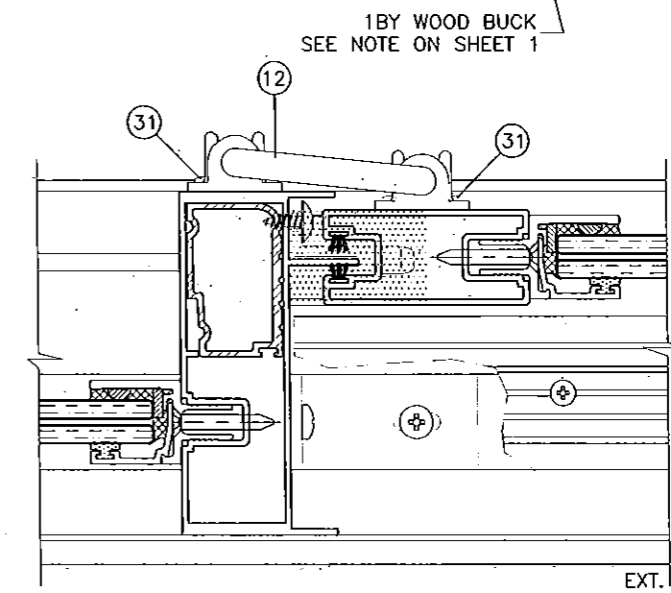
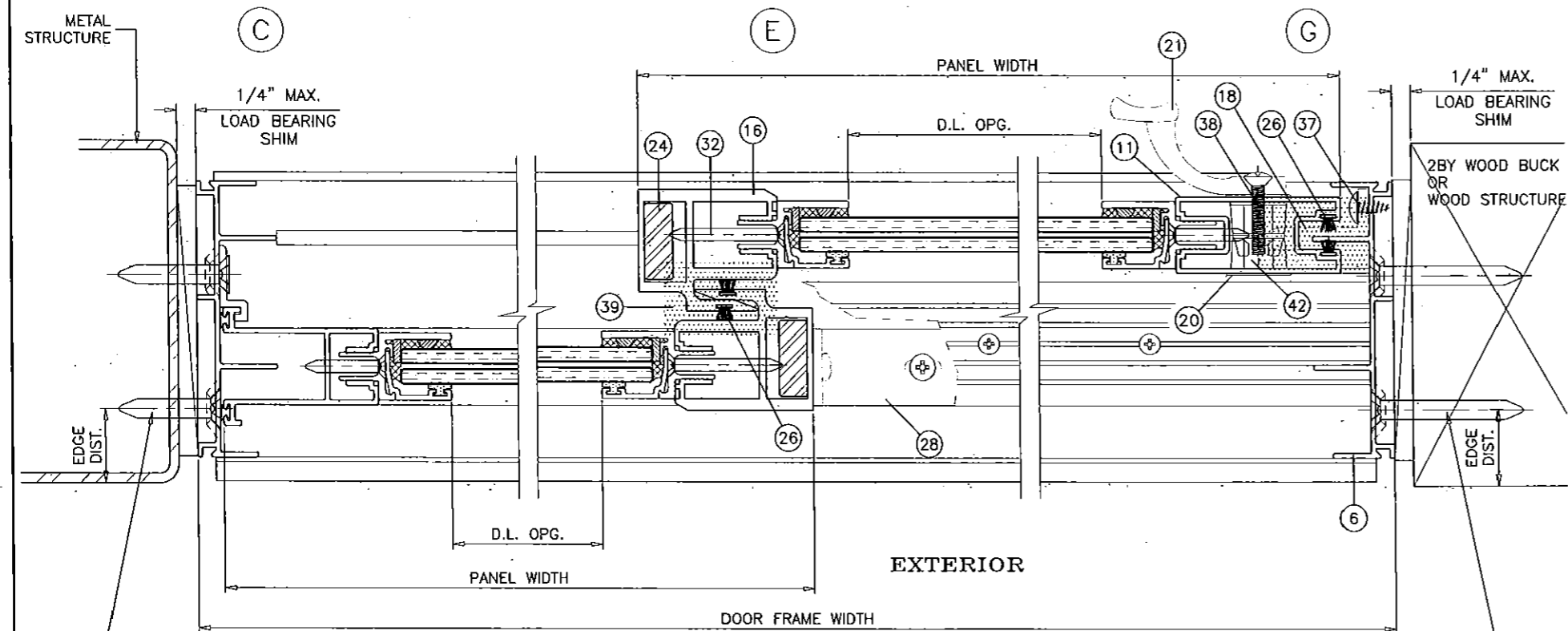
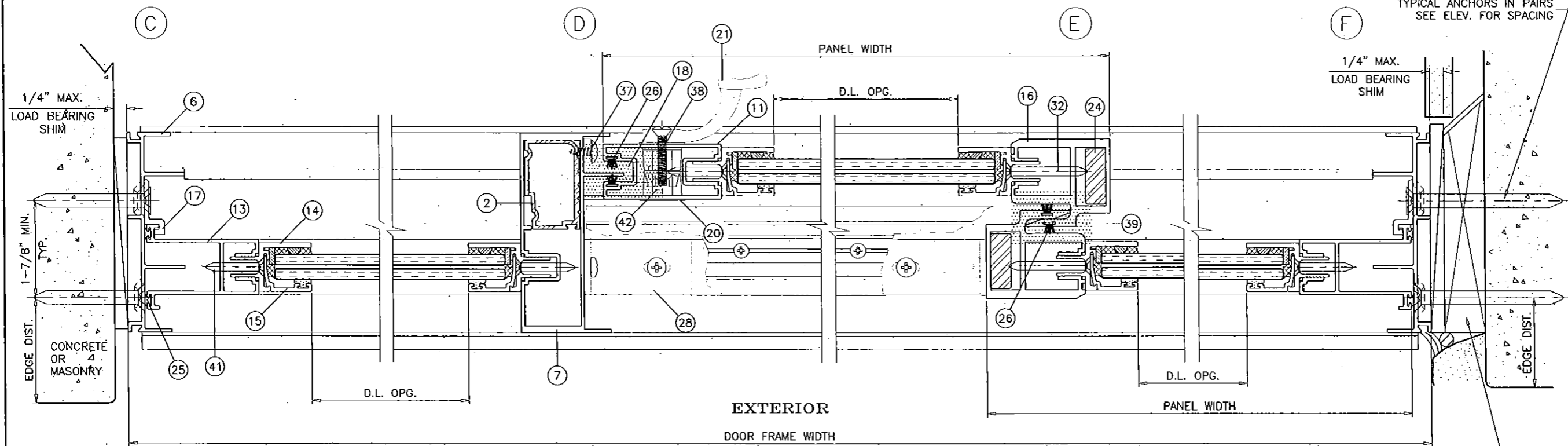

SECURITY LOCK AT ASTRAGAL STILE

SEE SHEET 1 FOR LOCATION
SEE SHEET 6 FOR DESCRIPTION

PRODUCT REVISED
as complying with the Florida
Building Code
Acceptance No 14-1103-02
Expiration Date 7/8/19
By Ismael L. Cham
Ismael Dada Product Control

Engr: JAVAD AHMAD
CIVIL
FLA. PE # 70592
C.A.N. 3538

[Signature]
MAY 06 2015

af c
AL-FAROOQ CORPORATION
ENGINEERS & PRODUCT DEVELOPMENT
1235 S.W. 87 AVE
MIAMI, FLORIDA 33174
TEL. (305) 264-8100 FAX. (305) 262-6978
COMP-ANL\W09-17AWP

SERIES 4100 ALUM SLD. GLASS DOOR (L.M.I.)
AWP WINDOWS AND DOORS, LLC
8130 N.W. 74TH AVE.
MEDLEY, FL. 33166
TEL. (305) 887-2646 FAX (305) 883-1309

NO	DATE	BY	DESCRIPTION
D	12.23.11	MANUF. NAME	REVISED
E	03.12.14	REV. PER	PER COMMENTS
F	05.27.14	NO CHANGE	THIS SHEET
G	06.25.14	MANUF. NAME	REV.

date:	03-11-09
scale:	1/2" = 1"
dr. by:	HAMID
chk. by:	

drawing no.	W09-17
sheet	4 of 6

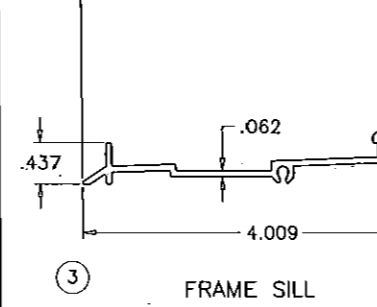
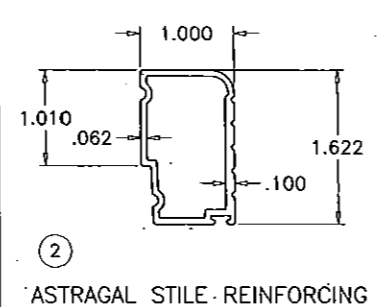
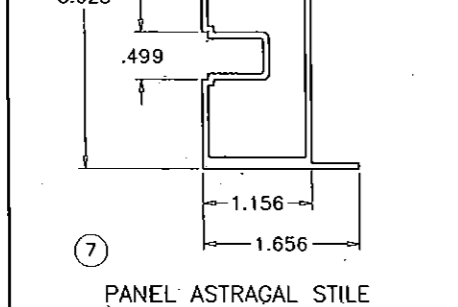
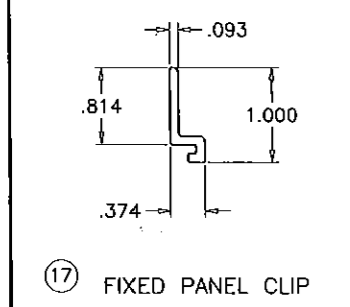
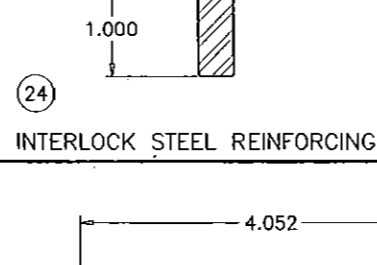
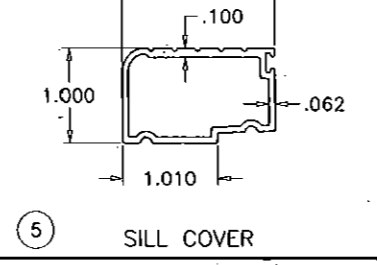
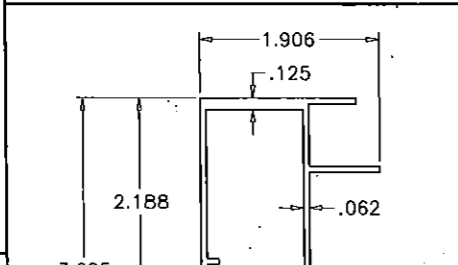
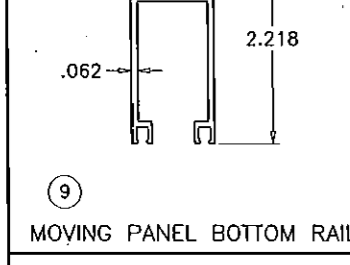
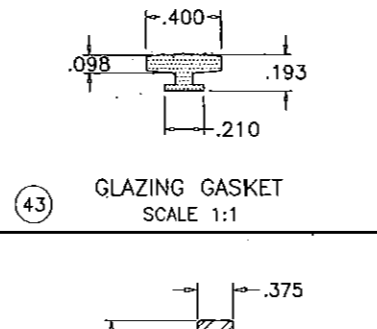
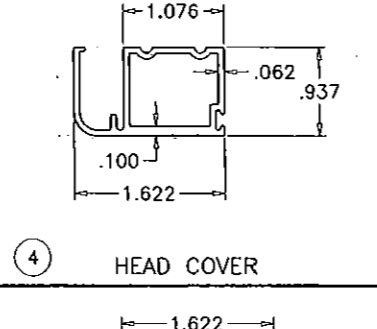
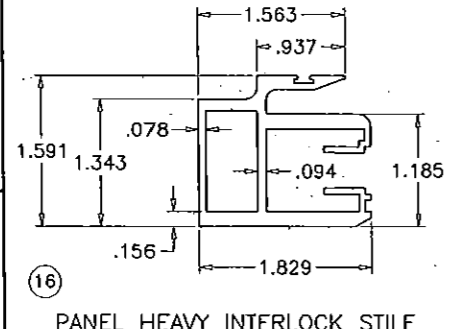
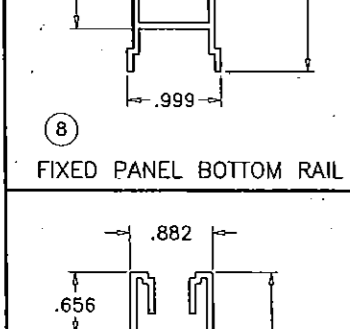
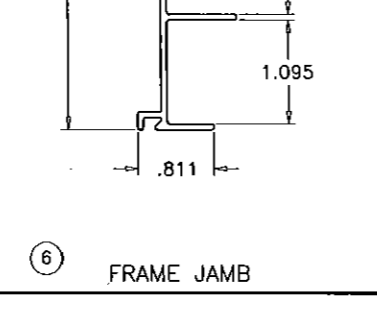
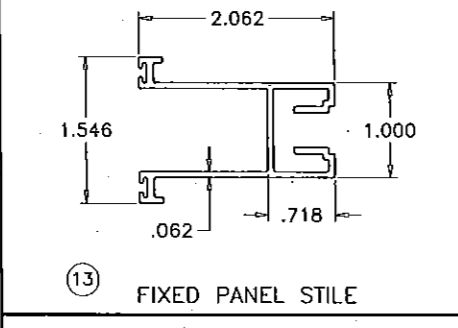
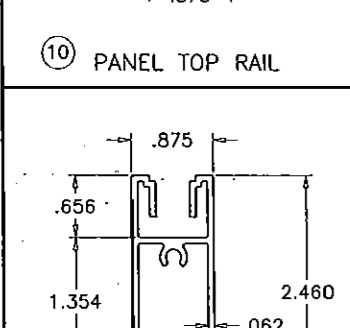
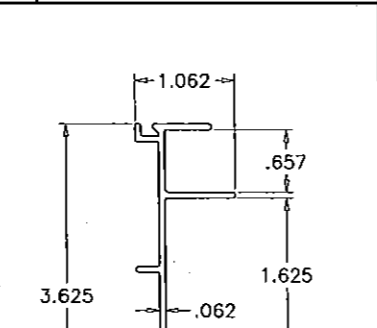
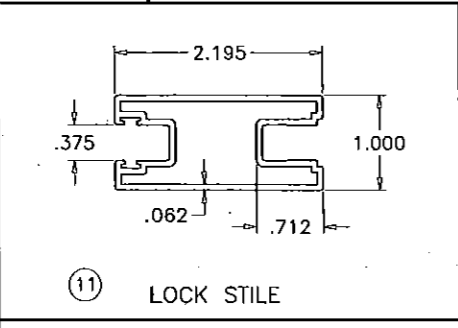
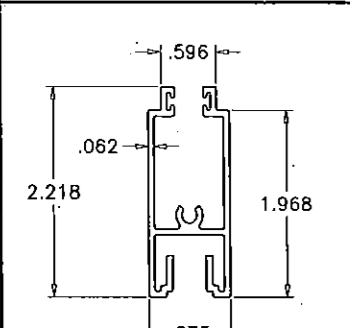
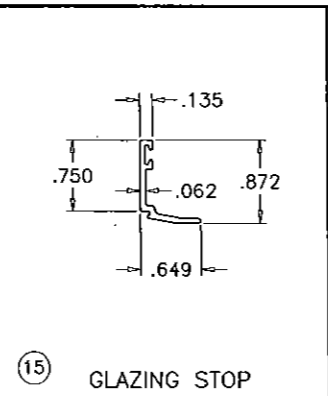
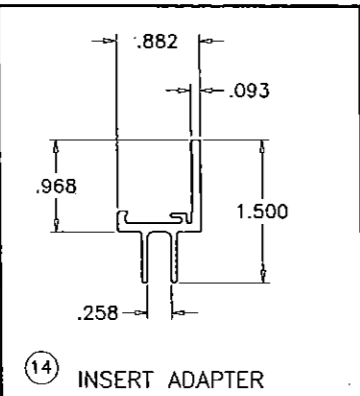
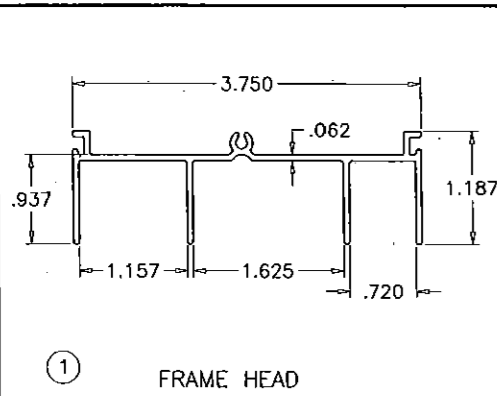

af c
AL-FAROOQ CORPORATION
 ENGINEERS & PRODUCT DEVELOPMENT
 1235 S.W. 87 AVE
 MIAMI, FLORIDA 33174
 TEL. (305) 264-8100 FAX. (305) 262-6978
 COMP-ANL\W09-17AWP

SERIES 4100 ALUM SLD. GLASS DOOR (L.M.I.)
AWP WINDOWS AND DOORS, LLC
 8130 N.W. 74TH AVE.
 MEDLEY, FL. 33166
 TEL. (305) 887-2646 FAX (305) 883-1309

PRODUCT REVISED
 as complying with the Florida
 Building Code
 Acceptance No. 14-103-02
 Expiration Date 7/8/19
 By Shahid Chaudhry
 Miami Dade Product Council

revisions:		by	description
no	date		
D	12.23.11	MANUF. NAME REVISED	
E	03.12.14	REV. PER RER COMMENTS	
F	05.27.14	NO CHANGE THIS SHEET	
G	06.25.14	MANUF. NAME REV.	

date: 03-11-09
 scale: 1/2" = 1"
 dr. by: HAMID
 chk. by:

drawing no.
W09-17
 sheet 5 of 6

Engr: JAVAD AHMAD
 CIVIL
 FLA. PE # 70592
 C.A.N. 3538
MAY 06 2015

ITEM	PART #	QUANTITY	DESCRIPTION	MATERIAL
1	YE-304	1	FRAME HEAD	ALUM. (6063-T6)
2	YE-3010	1	ASTRAGAL REINF. (FULL LENGTH)	ALUM. (6063-T6)
3	YE-373	1	FRAME SILL	ALUM. (6063-T6)
4	YE-309	1	HEAD COVER	ALUM. (6063-T6)
5	YE-3010	1	SILL COVER	ALUM. (6063-T6)
6	YE-303	2	FRAME JAMB	ALUM. (6063-T6)
7	YE-344	1	PANEL HEAVY ASTRAGAL STILE	ALUM. (6063-T6)
8	YE-379	2	PANEL BOTTOM RAIL (FIXED)	ALUM. (6063-T6)
9	YE-306	1	PANEL BOTTOM RAIL (MOVING)	ALUM. (6063-T6)
10	YE-307	3	PANEL TOP RAIL (FIXED & MOVING)	ALUM. (6063-T6)
11	YE-301	1	PANEL LOCKING STILE	ALUM. (6063-T6)
12	YH-4044	1	SECURITY LOCK @ 48" FROM BOTTOM, FASTENED W/ (4) #8 X 1" PH SMS	STEEL CHROME
13	YE-302	2	PANEL FIXED END STILE	ALUM. (6063-T6)
14	YE-382	12	INSERT ADAPTER (7/16" GLASS)	ALUM. (6063-T6)
15	YE-383	12	GLAZING STOP (7/16" GLASS)	ALUM. (6063-T6)
16	YE-325	2	PANEL HEAVY INTERLOCK STILE	ALUM. (6063-T6)
17	YE-377	2	FIXED PANEL CLIP (95" LONG)	ALUM. (6063-T6)
18	YH-4003	1	KEEPER	CAST (ZAMAK)
19	YH-4016	1	EXTERIOR CONCEALED HANDLE	CAST (ZAMAK)
20	YH-4017	1	INTERIOR CONCEALED HANDLE	CAST (ZAMAK)
21	YH-4022	1	DOOR HANDLE	CAST (ZAMAK)
22	YH-3023	2	ROLLER ASSEMBLY, FASTENED W/ (1) #10-24 X 7/8" PH MS	STEEL
23	YH-4002	2	PANEL TOP SLIDE GUIDE	NYLON
24	YH-4027	2	1" x .375" REINF. BAR (FULL PANEL LENGTH)	STEEL (A36)
25	YH-4010	AS REQ'D	BULB VINYL WEATHERSTRIP	VINYL
26	YH-4004	AS REQ'D	.187" x .250" WEATHERSTRIP	-
27	YH-6006	AS REQ'D	.115" x .500" WEATHERSTRIP	-
28	YH-4034	1	TYPE B CLIP (2 x 2 x 1 x 1/8")	ALUM. (6063-T6)
29	YH-4055	1	TYPE C CLIP (2 x 2 x 1 x 1/8")	ALUM. (6063-T6)
30	YH-4054	6	TYPE D CLIP (2 x 7/8. x 1/8 x 3")	ALUM. (6063-T6)
31	-	8	#8 x 3/4" PH. P.H: SMS.	CAD PLATED
32	-	AS REQ'D	#8 x 1-1/2" FH. SMS.	CAD PLATED
33	YF-2	46	#10 x 1" PH. SMS. (PANELS/CLIPS)	CAD PLATED
34	YF-17	1/WHEEL	#10-24 x 7/8" PH. MS.(WHEEL ADJ)	CAD PLATED
35	YF-10	4/FRAME	#8 x 1" PH. SMS. (FRAME ASSY.)	CAD PLATED
36	-	6	#10 x 1-1/4" P.H. SMS.	CAD PLATED
37	YF-18	2	#10 x 3/8" TRUSS HEAD SMS.	CAD PLATED
38	YF-27	2	#10-32 x 1" OVAL HEAD. SS. MS.	STAINLESS STEEL
39	YH-4013	4	PAD (INTRLK/ASTRAGAL (TOP/BOTTOM)	-
40	GB125375	AS REQ'D	GLAZING SPACER	-
41	-	AS REQ'D	#10 x 1-1/4" FH. SMS.	CAD PLATED
42	-	1	HOOK LOCK	METALLIC
43	YH-624	AS REQD.	GLAZING GASKET, DUROMETER 70±5 SHORE A BY MELTPOINT PLASTICS (TEKNOR APEX COMPANY)	VINYL

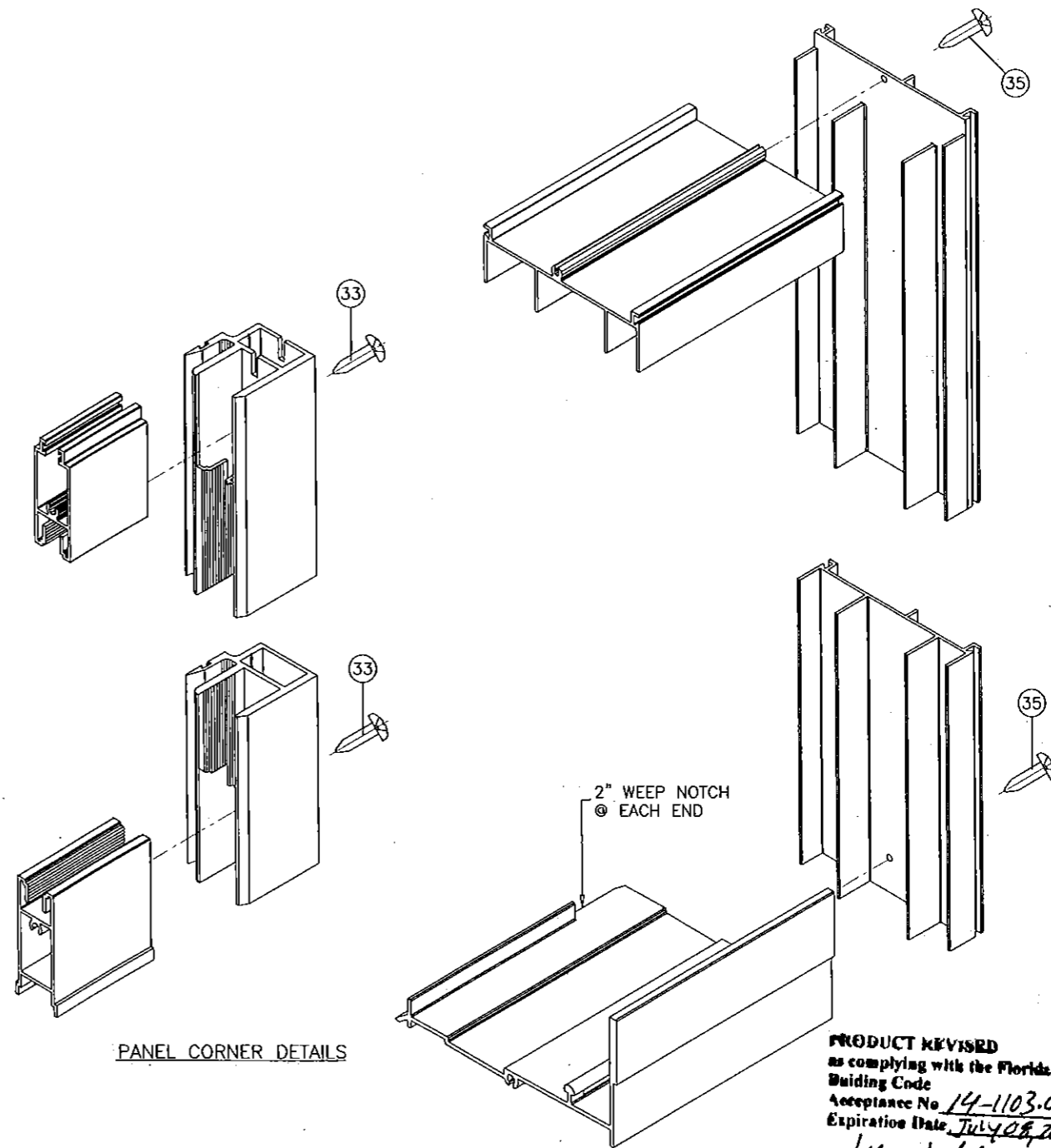

PANEL CORNER DETAILS

FRAME CORNER DETAIL

PRODUCT REVISED
 as complying with the Florida
 Building Code
 Acceptance No. 14-1103.02
 Expiration Date July 08, 2019
 By: *Yahya I. Chan*
 Miami Dade Product Control

Engr: JAVAD AHMAD
 CIVIL
 FLA. PE # 70592
 C.A.N. 3838
 MAY 16 2015

afC
AL-FAROOQ CORPORATION
 ENGINEERS & PRODUCT DEVELOPMENT
 1235 S.W. 87 AVE
 MIAMI, FLORIDA 33174
 TEL. (305) 264-8100 FAX (305) 262-6978
 COMP-ANL\W09-17AWP

SERIES 4100 ALUM SLD. GLASS DOOR (L.M.I.)
AWP WINDOWS AND DOORS, LLC
 8130 N.W. 74TH AVE.
 MEDLEY, FL. 33166
 TEL. (305) 887-2646 FAX (305) 883-1309

no	date	description	MANUF. NAME REVISED	REV. PER COMMENTS	REV. PER COMMENTS	MANUF. NAME REV.
D	12.23.11					
E	03.12.14					
F	05.27.14					
G	06.25.14					

date: 03-11-09
 scale: 1/2" = 1"
 dr. by: HAMID
 chk. by:
 drawing no.
W09-17
 sheet 6 of 6