

REVISIONS			
REV	DESCRIPTION	DATE	APPROVED
A	REMOVED TRIPLE UNIT	03/20/13	R.L.
B	REVISED INSTALLATION DETAILS	02/01/16	R.L.
C	REVISED GLAZING DETAIL	01/08/18	R.L.

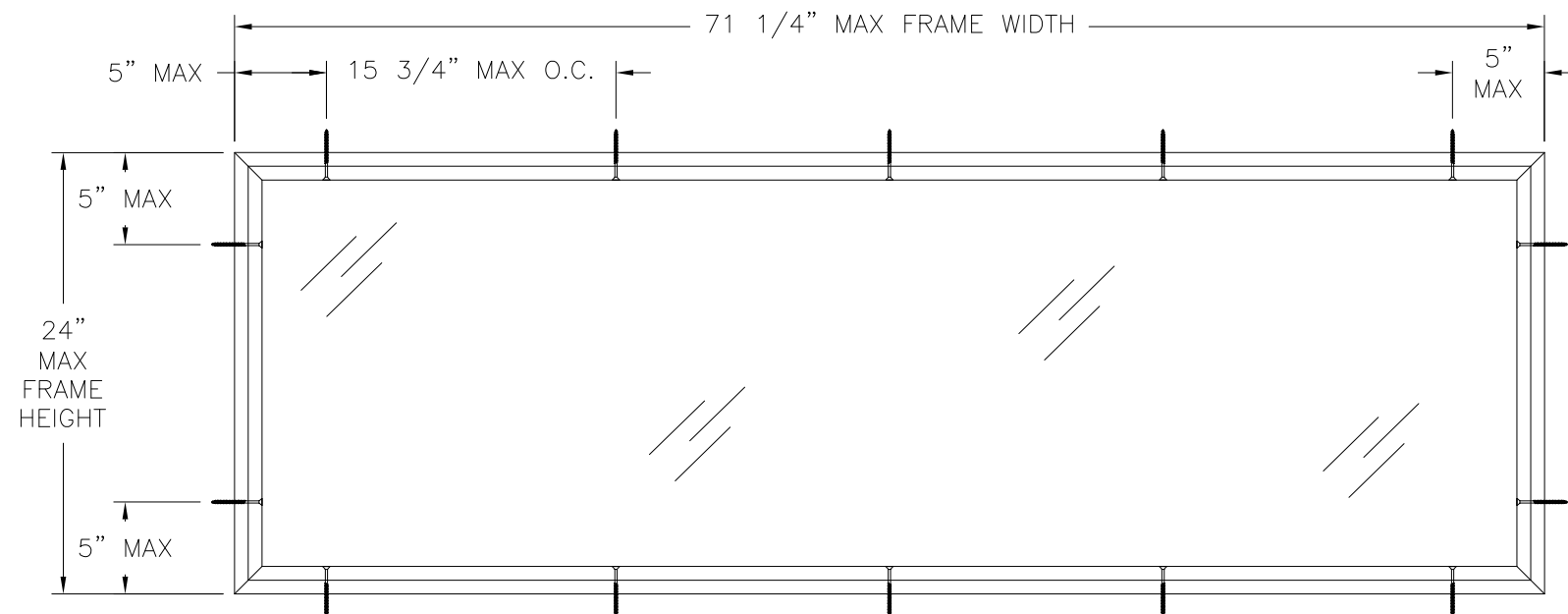

GTI 6020 IN-SWING TRANSOM - IMPACT
EXTERIOR VIEW

DESIGN PRESSURE RATING	IMPACT RATING
±80.0PSF	LARGE AND SMALL MISSILE IMPACT

MISSILE LEVEL D, WIND ZONE 4, AND HVHZ

- NOTES:
1. MAXIMUM D.L.O.: 68 1/4" X 21"

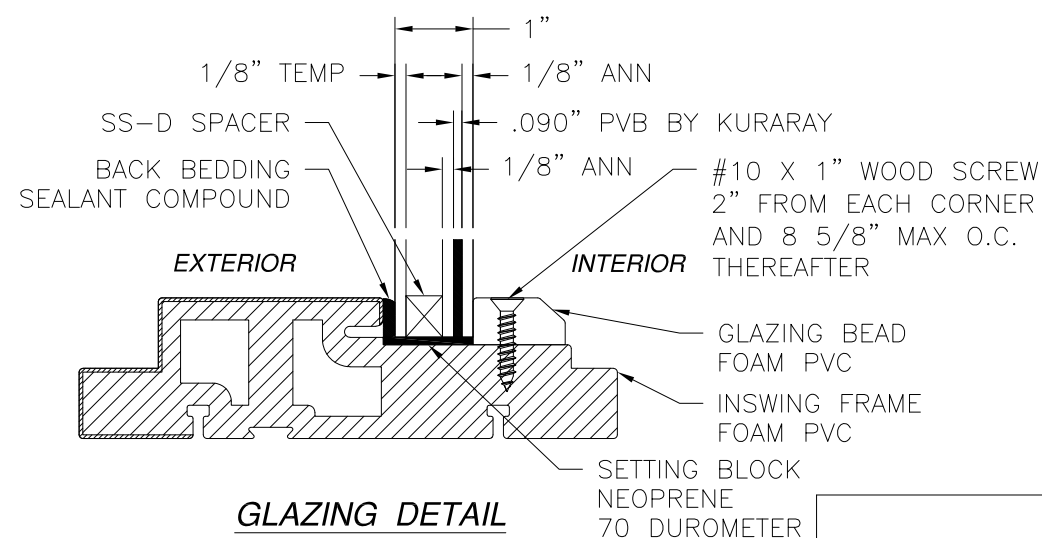

GLAZING DETAIL

NOTES:

- THE PRODUCT SHOWN HEREIN IS DESIGNED AND MANUFACTURED TO COMPLY WITH REQUIREMENTS OF THE FLORIDA BUILDING CODE INCLUDING THE HVHZ.
- WOOD FRAMING AND MASONRY OPENING TO BE DESIGNED AND ANCHORED TO PROPERLY TRANSFER ALL LOADS TO STRUCTURE. FRAMING AND MASONRY OPENING IS THE RESPONSIBILITY OF THE ARCHITECT OR ENGINEER OF RECORD.
- 1X BUCK OVER MASONRY/CONCRETE IS OPTIONAL. WHERE 1X BUCK IS NOT USED DISSIMILAR MATERIALS MUST BE SEPARATED WITH APPROVED COATING OR MEMBRANE. SELECTION OF COATING OR MEMBRANE IS THE RESPONSIBILITY OF THE ARCHITECT OR ENGINEER OF RECORD.
- ALLOWABLE STRESS INCREASE OF 1/3 WAS NOT USED IN THE DESIGN OF THE PRODUCT SHOWN HEREIN. WIND LOAD DURATION FACTOR Cd=1.6 WAS USED FOR WOOD ANCHOR CALCULATIONS.
- FRAME MATERIAL: EXTRUDED RIGID FOAM PVC.
- UNITS MUST BE GLAZED PER ASTM E1300-04/09, SEE SHEET 1 FOR GLASS DETAILS.
- APPROVED IMPACT PROTECTIVE SYSTEM IS NOT REQUIRED FOR THIS PRODUCT IN WIND BORNE DEBRIS REGIONS.
- SHIM AS REQUIRED AT EACH INSTALLATION ANCHOR WITH LOAD BEARING SHIM. SHIM WHERE SPACE OF 1/16" OR GREATER OCCURS. MAXIMUM ALLOWABLE SHIM STACK TO BE 1/4".
- FOR ANCHORING INTO WOOD FRAMING OR 2X BUCK USE #10 WOOD SCREWS WITH SUFFICIENT LENGTH TO ACHIEVE A 1 3/8" MINIMUM EMBEDMENT INTO SUBSTRATE. LOCATE ANCHORS AS SHOWN IN ELEVATIONS AND INSTALLATION DETAILS.
- FOR ANCHORING INTO MASONRY/CONCRETE USE 3/16" TAPCONS WITH SUFFICIENT LENGTH TO ACHIEVE A 1 1/4" MINIMUM EMBEDMENT INTO SUBSTRATE WITH 2 5/8" MINIMUM EDGE DISTANCE. LOCATE ANCHORS AS SHOWN IN ELEVATIONS AND INSTALLATION DETAILS.
- ALL FASTENERS TO BE CORROSION RESISTANT.
- INSTALLATION ANCHORS SHALL BE INSTALLED IN ACCORDANCE WITH ANCHOR MANUFACTURER'S INSTALLATION INSTRUCTIONS AND ANCHORS SHALL NOT BE USED IN SUBSTRATES WITH STRENGTHS LESS THAN THE MINIMUM STRENGTH SPECIFIED BELOW:
 - WOOD - MINIMUM SPECIFIC GRAVITY OF G=0.42
 - CONCRETE - MINIMUM COMPRESSIVE STRENGTH OF 3,192 PSI.
 - MASONRY - STRENGTH CONFORMANCE TO ASTM C-90, GRADE N, TYPE 1 (OR GREATER).
- TRANSOM UNITS MAY BE INSTALLED VERTICALLY OR HORIZONTALLY.

SIGNED: 01/08/2018

NAN YA PLASTICS CORP. USA

8989 NORTH LOOP EAST
HOUSTON, TX 77029

SERIES IN-SWING TRANSOM, VINYL TRANSOM
WINDOW GTI 6020 IMPACT
ELEVATION AND NOTES

DRAWN: V.L.	DWG NO. 08-01895	REV C
SCALE NTS	DATE 01/15/13	SHEET 1 OF 2

L. ROBERTO LOMAS P.E.
1432 WOODFORD RD LEWISVILLE, NC 27023
434-688-0609 rllomas@rlomaspe.com

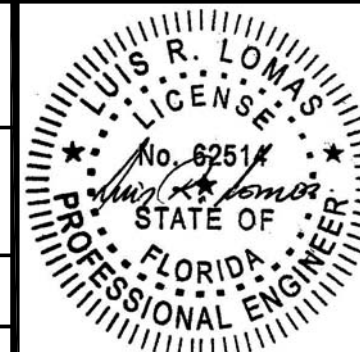

Luis R. Lomas P.E.
FL No.: 62514

TABLE OF CONTENTS	
SHEET NO.	DESCRIPTION
1	ELEVATIONS AND NOTES
2	INSTALLATION DETAILS

REVISIONS			
REV	DESCRIPTION	DATE	APPROVED
A	REMOVED TRIPLE UNIT	03/20/13	R.L.
B	REVISED INSTALLATION DETAILS	02/01/16	R.L.
C	REVISED GLAZING DETAIL	01/08/18	R.L.

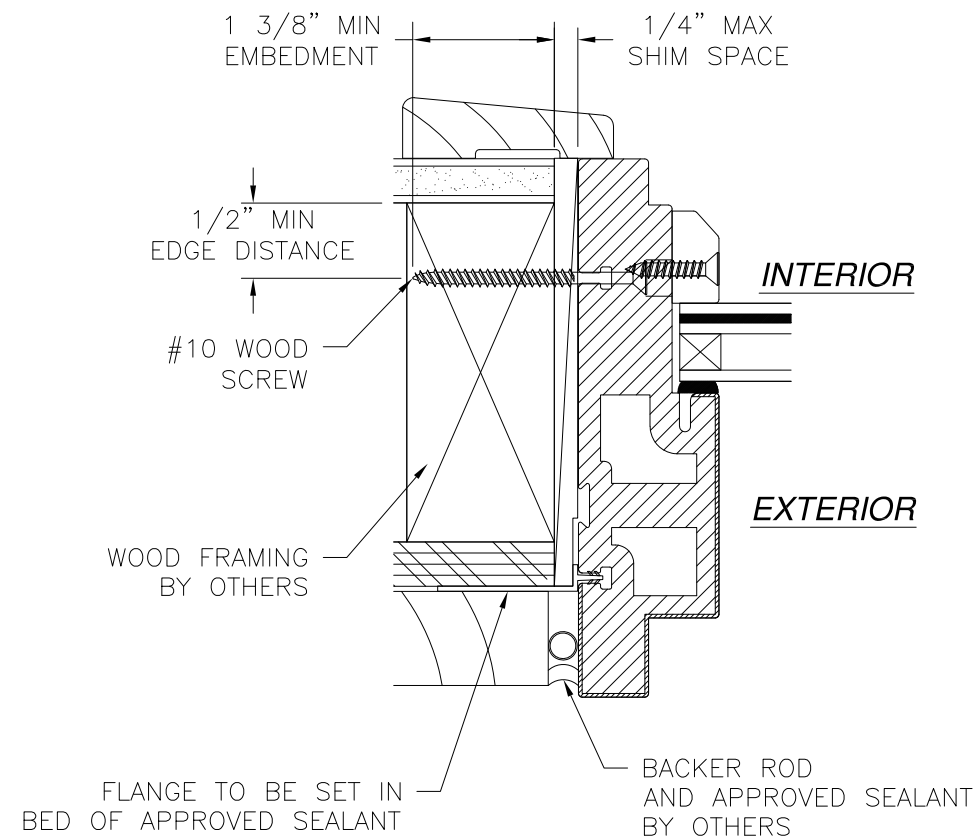

HORIZONTAL CROSS SECTION
2X BUCK/WOOD FRAMING INSTALLATION
JAMB SHOWN HEAD AND SILL SIMILAR

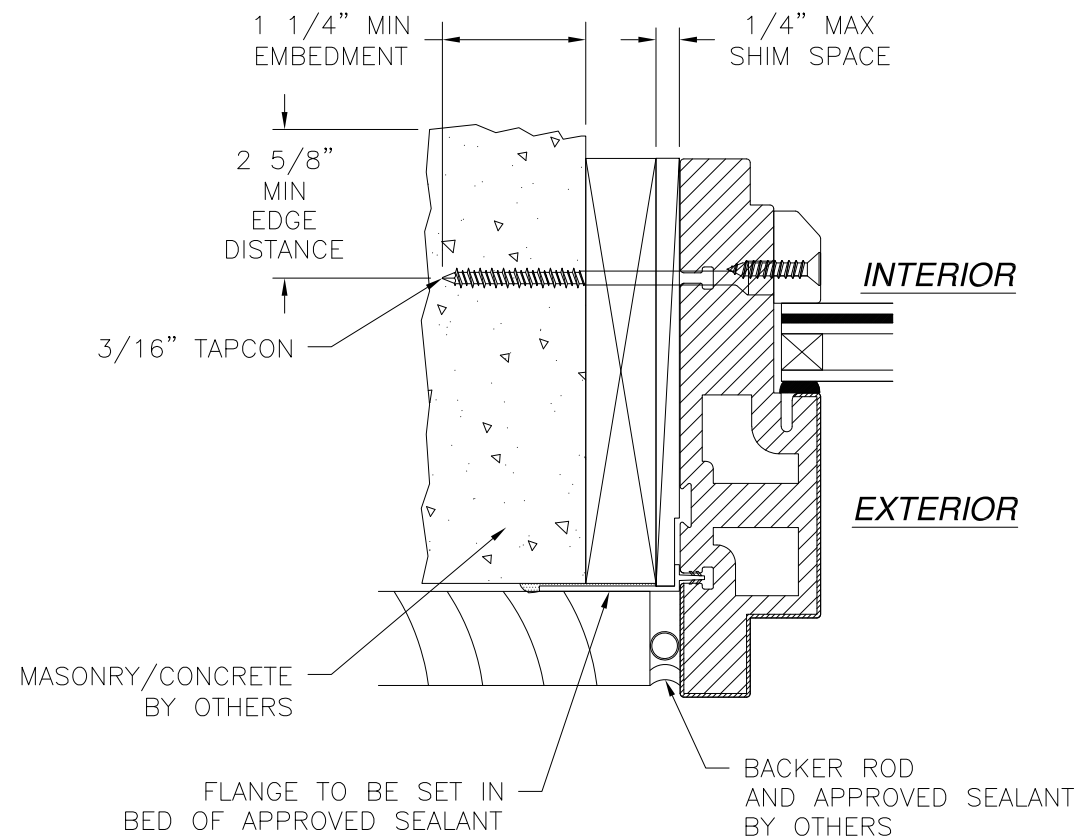

HORIZONTAL CROSS SECTION
MASONRY/CONCRETE INSTALLATION
JAMB SHOWN HEAD AND SILL SIMILAR

NOTES:

1. INTERIOR AND EXTERIOR FINISHES, BY OTHERS, NOT SHOWN FOR CLARITY.
2. PERIMETER AND JOINT SEALANT BY OTHERS TO BE DESIGNED IN ACCORDANCE WITH ASTM E2112

SIGNED: 01/08/2018

NAN YA PLASTICS CORP. USA 8989 NORTH LOOP EAST HOUSTON, TX 77029		
SERIES IN-SWING TRANSOM, VINYL TRANSOM WINDOW GTI 6020 IMPACT INSTALLATION DETAILS		
DRAWN: V.L.	DWG NO. 08-01895	REV C
SCALE NTS	DATE 01/15/13	SHEET 2 OF 2
L. ROBERTO LOMAS P.E. 1432 WOODFORD RD LEWISVILLE, NC 27023 434-688-0609 rllomas@lrlomaspe.com		

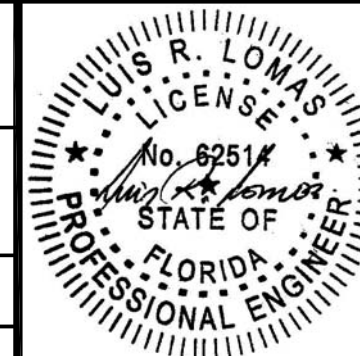

Luis R. Lomas P.E.
 FL No.: 62514