

NOTES:

1. FOR GENERAL SPECIFICATIONS, REFER TO DOCUMENT 00003952
2. THIS PRINT IS FOR STRUCTURAL PERFORMANCE ONLY. FOR FLASHING AND SEALING INSTRUCTIONS REFER TO THE INSTALLATION INSTRUCTIONS
3. SHIMS:
PLACE A SHIM AT EACH LOCATIONS WHERE A SCREW PASSES THROUGH THE JAMB/ HEAD JAMB AND INTO THE BUCK, INCLUDING HINGE AND STRIKE LOCATIONS. ADDITIONAL SHIMS MUST BE PLACED A MAXIMUM OF 15" APART ON CENTER.
4. IF CHEMICALLY TREATED LUMBER IS USED FOR BUCK MATERIAL, FASTENERS INTO THE BUCK MUST BE A MINIMUM OF 0.90 OZ/FT² ZINC HOT DIPPED GALVANIZED OR STAINLESS STEEL TYPE 304 OR 316
5. FOR DRAWING LIMITATIONS AND CONDITIONS OF USE, REFER TO EVALUATION REPORT FL 10196
6. NO INSTALLATION SCREWS NEEDED ON 3080 - O
7. INSTALLATION SCREWS ARE THROUGH TOP HOLE IN EVERY HINGE & THE TWO INTERIOR HOLES FOR HEADER STRIKE
8. INSTALLATION HOLES THROUGH SILL LINER ARE PRE-DRILLED ON 2 PANEL UNITS ONLY
9. APPROVED FOR PRODUCTS:
- FL 10196 - ELOFD
10. MINIMUM NAIL EMBEDMENT DEPTH: 1-15/16"
11. MINIMUM EDGE DISTANCE: 1/2"
12. GLASS COMPLIES WITH ASTM E1300

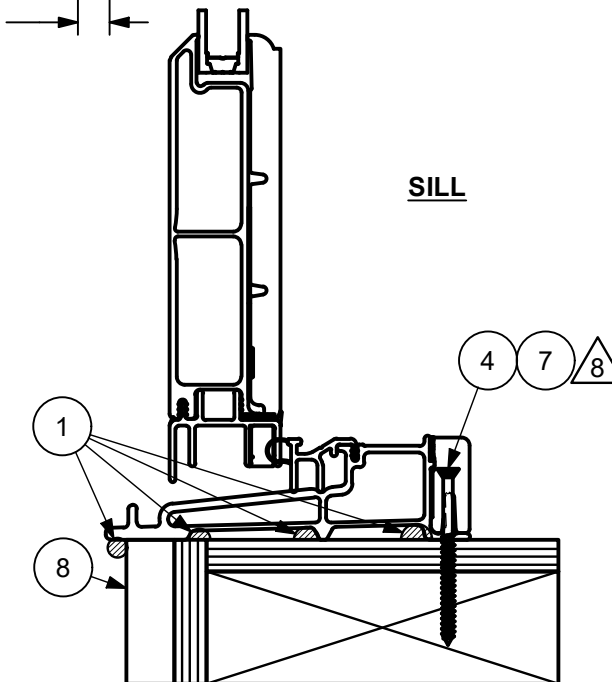

SILL INSTALLATION:

- PLACE THREE 3/8" DIAMETER BEADS OF ASTM C920 GRADE NS CLASS 25 SEALANT ON SILL PLATE
- ANCHOR THE SILL AT THE CENTER WITH TWO #10 X 3" SHEET METAL SCREW. IF CONCRETE CONSTRUCTION, USE TWO 3/16" X 2-3/4" MASONRY SCREW

CATEGORY:

SWINGING FRENCH DOOR

UNIT TYPE:

ELOFD

ITEM	DWG NO	DESCRIPTION
8	NA	3/4" WOOD LATH
7	NA	#10 X 3" SCREW
6	NA	2" GALVANIZED ROOFING NAIL
5	NA	SHIM
4	00064718	3/16" X 2-3/4" MASONRY
3	0003228	#8 X 2-1/2" PH, PH SCREW
2	NA	FRAMING MATERIAL
1	NA	ASTM C920 GRADE NS CLASS 25 SEALANT

MARVIN RESEARCH & DEVELOPMENT

COLLECTION: ELEVATE

DWG TYPE: INSTALLATION
DESCRIPTION: INSTALLATION METHODS/ELEVATIONS, NAIL FIN, FL 10196

CHK: SAL 12/22	SIZE: B	CLASS: MISC	DWG NO: 00047608
APP: SRB 12/23/20	SCALE: 1:3	DATE: 02/19/07	DWG BY: HEPPNER, CALEB SHEET: 1 OF 1

REV	DESCRIPTION / REQUESTOR	ECN NO	DATE	REV BY
13.1	ADDED NOTE 12	23921	12/21/20	TDG
13.0	UPDATED TAXONOMY OF BRANDS	23921	06/12/19	TDG
12.0	UPDATED MODEL (PANEL EUROGROOVE WEATHERSTRIP, TOP RAIL WEATHERSTRIP)	21926	09/27/17	GMB

NOTICE - CONFIDENTIAL INFORMATION

The information in this document is privileged and strictly confidential. The information contained herein shall be used only by Marvin employees and by those agents or suppliers granted official written permission. If the reader of this document is not the intended recipient, or the employee or agent of the intended recipient, please delete this document from all data storage devices, and destroy all hard copies. Any unauthorized dissemination, distribution, copying or other use of the information contained in this document is strictly prohibited.