

NOTES:

1. FOR GENERAL SPECIFICATIONS, REFER TO DOCUMENT 00003952
2. THIS PRINT IS FOR STRUCTURAL PERFORMANCE ONLY. FOR FLASHING AND SEALING INSTRUCTIONS REFER TO THE INSTALLATION INSTRUCTIONS
3. SHIMS:
PLACE A SHIM AT EACH LOCATIONS WHERE A SCREW PASSES THROUGH THE JAMB/ HEAD JAMB AND INTO THE BUCK, INCLUDING HINGE AND STRIKE LOCATIONS. ADDITIONAL SHIMS MUST BE PLACED A MAXIMUM OF 15" APART ON CENTER.
4. IF CHEMICALLY TREATED LUMBER IS USED FOR BUCK MATERIAL, FASTENERS INTO THE BUCK MUST BE A MINIMUM OF 0.90 OZ/FT² ZINC HOT DIPPED GALVANIZED OR STAINLESS STEEL TYPE 304 OR 316
5. FOR DRAWING LIMITATIONS AND CONDITIONS OF USE, REFER TO EVALUATION REPORT FL 8259
6. NO INSTALLATION SCREWS NEEDED ON 3080 - O
7. INSTALLATION SCREWS ARE THROUGH TOP HOLE IN EVERY HINGE & THE TWO INTERIOR HOLES FOR HEADER STRIKE
8. INSTALLATION HOLES THROUGH SILL LINER ARE PRE-DRILLED ON 2 PANEL UNITS ONLY
9. APPROVED FOR PRODUCTS:
- FL 8259 - IOFD
10. MINIMUM NAIL EMBEDMENT DEPTH 1 15/16" (NAILING FIN INSTALLATION ONLY)
11. MINIMUM EDGE DISTANCE 1/2" (NAILING FIN INSTALLATION ONLY)

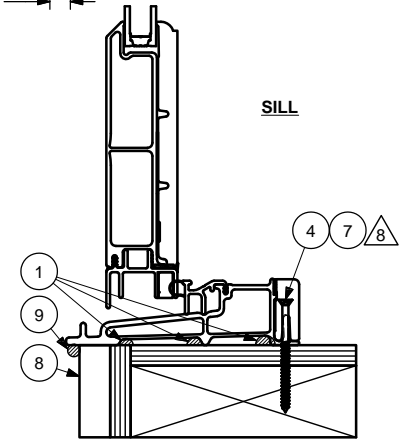

SILL INSTALLATION:

- PLACE THREE 3/8" DIA BEADS OF NS CLASS 25 SEALANT PER ASTM C920 ON SILL PLATE
- ANCHOR THE SILL AT THE CENTER WITH TWO #10 X 3" SHEET METAL SCREW, IF CONCRETE CONSTRUCTION, USE TWO 3/16" X 2.75" MASONRY SCREW

9	NA	SILICONE SEALANT
8	NA	3/4" WOOD LATH
7	NA	#10 X 3" SCREW
6	NA	2.000 GALVANIZED ROOFING NAIL
5	NA	SHIM
4	00064718	3/16" 2.75" MASONRY
3	0003228	#8 X 2.500" PH, PH SCREW
2	NA	FRAMING MATERIAL
1	NA	CLASS 25 SEALANT
ITEM	DWG NO	DESCRIPTION
PARTS LIST		

MARVIN Windows and Doors **RESEARCH & DEVELOPMENT** WARROAD, MN, USA, (218) 386-4021

PRODUCT CATEGORY: INTEGRITY WOOD ULTREX

UNIT TYPE: IOFD

DWG TYPE: INSTALLATION
DESCRIPTION: FLORIDA INSTALL, FL10196

CHK: CSH **SIZE:** B **CLASS:** MISC **DWG NO:** 00047608

APP: DRT **SCALE:** 1:3 **DATE:** 02/19/07 **DWG BY:** HEPPNER, CALEB **SHEET:** 1 OF 1

Template Version 10.5

11.4	UPDATED MODEL (SILL STRIKE XX, SILL STRIKE PLATE XX, PANEL CORNER KEY SCREWS, MULTI-POINT SCREWS, HINGE S WEDGE)	21604	06/16/17	GMB
11.3	UPDATED MODEL (WOOD PROFILE)	21604	04/05/17	JDF
REV	DESCRIPTION / REQUESTOR	ECN NO	DATE	REV BY

NOTICE - CONFIDENTIAL INFORMATION

The information in this document is privileged and strictly confidential. The information contained herein shall be used only by Marvin Windows and Doors employees and by those agents or suppliers granted official written permission. If the reader of this document is not the intended recipient, or the employee or agent of the intended recipient, please delete this document from all data storage devices, and destroy all hard copies. Any unauthorized dissemination, distribution, copying or other use of the information contained in this document is strictly prohibited.