

REGENCY PLUS, INC.

SERIES 3000/4000 VINYL FIXED WINDOW

INSTALLATION ANCHORAGE DETAILS

NOTES:

1. THE PRODUCT SHOWN HEREIN IS DESIGNED AND MANUFACTURED TO COMPLY WITH REQUIREMENTS OF THE CURRENT FLORIDA BUILDING CODE EXCLUDING THE HIGH VELOCITY HURRICANE ZONE (HVHZ).
2. WOOD FRAMING, 2X WOOD BUCK, METAL FRAMING AND CONCRETE/MASONRY OPENING TO BE DESIGNED AND ANCHORED TO PROPERLY TRANSFER ALL LOADS TO STRUCTURE. FRAMING AND CONCRETE/MASONRY OPENING IS THE RESPONSIBILITY OF THE ARCHITECT OR ENGINEER OF RECORD.
3. 1X BUCK OVER CONCRETE/MASONRY IS OPTIONAL. WHERE 1X BUCKS ARE USED, INSTALLATION ANCHORS WILL PASS THROUGH WINDOW FRAME AND 1X BUCK INTO CONCRETE/MASONRY SUBSTRATE. WHERE 1X BUCK IS NOT USED, INSTALLATION ANCHORS WILL PASS THROUGH WINDOW FRAME INTO CONCRETE/MASONRY SUBSTRATE. DISSIMILAR MATERIALS MUST BE SEPARATED WITH APPROVED COATING OR MEMBRANE. SELECTION OF COATING OR MEMBRANE IS THE RESPONSIBILITY OF THE ARCHITECT OR ENGINEER OF RECORD.
4. THE PRODUCT SHOWN HEREIN HAS BEEN TESTED TO AAMA/NWWDA 101/I.S.2-97. SEE TEST REPORT NO. NCTL-210-2747-1 DATED 1/7/02 BY NATIONAL CERTIFIED TESTING LABORATORIES, ORLANDO, FL FOR DETAILS.
5. MATERIAL:
 - 5.1. FRAME: EXTRUDED RIGID PVC.
6. GLAZING:
 - 6.1. GLAZING DETAIL AS TESTED: 7/8" NOMINAL O.A. IGU COMPRISED OF 2 LITES OF 1/8" TEMPERED GLASS AND STEEL SPACER. PANEL INTERIOR GLAZED USING SEALED INSULATING GLASS WITH A FOAM TAPE BACK BEDDING AND A SNAP-IN DOUBLE LEAFED DUAL DUROMETER RIGID VINYL GLAZING BEAD.
 - 6.2. AS TESTED GLAZING MEETS ASTM E1300-09a FOR THE DESIGN CONDITIONS SHOWN IN THIS PRODUCT APPROVAL DOCUMENT.
 - 6.3. ALTERNATE GLAZING MEETING THE REQUIREMENTS OF AAMA/WDMA/CSA 101/I.S.2/A440 SHALL BE ALLOWED PER ASTM E1300.
7. APPROVED IMPACT PROTECTIVE SYSTEM IS REQUIRED FOR THIS PRODUCT IN WIND BORNE DEBRIS REGIONS.
8. SHIM AS REQUIRED AT EACH INSTALLATION ANCHOR WITH LOAD BEARING SHIM. SHIM WHERE SPACE OF 1/16" OR GREATER OCCURS. MAXIMUM ALLOWABLE SHIM STACK TO BE 1/4".
9. FOR ANCHORING INTO CONCRETE/MASONRY USE 3/16" HEX HEAD TAPCONS WITH SUFFICIENT LENGTH TO ACHIEVE A 1 1/2" MINIMUM EMBEDMENT INTO CONCRETE WITH 1 1/8" MINIMUM EDGE DISTANCE AND 1" MINIMUM EMBEDMENT INTO MASONRY WITH 2" MINIMUM EDGE DISTANCE. LOCATE ANCHORS AS SHOWN IN ELEVATIONS AND INSTALLATION DETAILS. ANCHOR LOCATIONS HAVE +/- 1" TOLERANCE.
10. FOR ANCHORING INTO WOOD FRAMING OR 2X BUCK USE #10 PAN HEAD WOOD SCREWS WITH SUFFICIENT LENGTH TO ACHIEVE A 1 3/8" MINIMUM EMBEDMENT INTO SUBSTRATE WITH 3/4" MINIMUM EDGE DISTANCE. LOCATE ANCHORS AS SHOWN IN ELEVATIONS AND INSTALLATION DETAILS. ANCHOR LOCATIONS HAVE +/- 1" TOLERANCE.
11. FOR ANCHORING INTO METAL STRUCTURE USE #10 PAN OR HEX HEAD SMS OR SELF DRILLING SCREWS WITH SUFFICIENT LENGTH TO ACHIEVE 3 THREADS MINIMUM BEYOND STRUCTURE INTERIOR WALL WITH 3/4" MINIMUM EDGE DISTANCE. LOCATE ANCHORS AS SHOWN IN ELEVATIONS AND INSTALLATION DETAILS. ANCHOR LOCATIONS HAVE +/- 1" TOLERANCE.
12. ALL FASTENERS TO BE CORROSION RESISTANT.
13. INSTALLATION ANCHORS SHALL BE INSTALLED IN ACCORDANCE WITH ANCHOR MANUFACTURER'S INSTALLATION INSTRUCTIONS AND ANCHORS SHALL NOT BE USED IN SUBSTRATES WITH STRENGTHS LESS THAN THE MINIMUM STRENGTH SPECIFIED BELOW:
 - 13.1. WOOD - MINIMUM SPECIFIC GRAVITY OF (G) 0.42 (NON-HVHZ)
 - 13.2. CONCRETE - MINIMUM COMPRESSIVE STRENGTH OF 2500 PSI
 - 13.3. MASONRY - STRENGTH CONFORMANCE TO ASTM C-90, MEDIUM WEIGHT WITH DENSITY > 117 PCF
 - 13.4. METAL STRUCTURE: STEEL 18GA (0.0428"), 33KSI OR ALUMINUM 6063-T5 0.048" THICK MINIMUM

PROJECT #417-0906

		UPDATE TO CURRENT EDITION OF FBC	1/22/18
	A	DESCRIPTION	DATE
	REV		BY

REGENCY PLUS, INC.
 2000 LOCUST GAP HIGHWAY
 MT. CARMEL, PA 17851

TITLE: SERIES 3000/4000 VINYL FIXED WINDOW
 NOTES

DRAWN BY: RJA	DATE: 1/11/18
SCALE: N.T.S.	DRAWING NO: RPLS0053
REV: A	SHEET: 1 OF 3

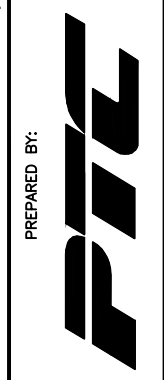

Robert J. Amoruso, P.E.
Florida P.E. No. 49752

TABLE OF CONTENTS	
SHEET	DESCRIPTION
1	NOTES
2	ELEVATION & ANCHORING
3	INSTALLATION DETAILS

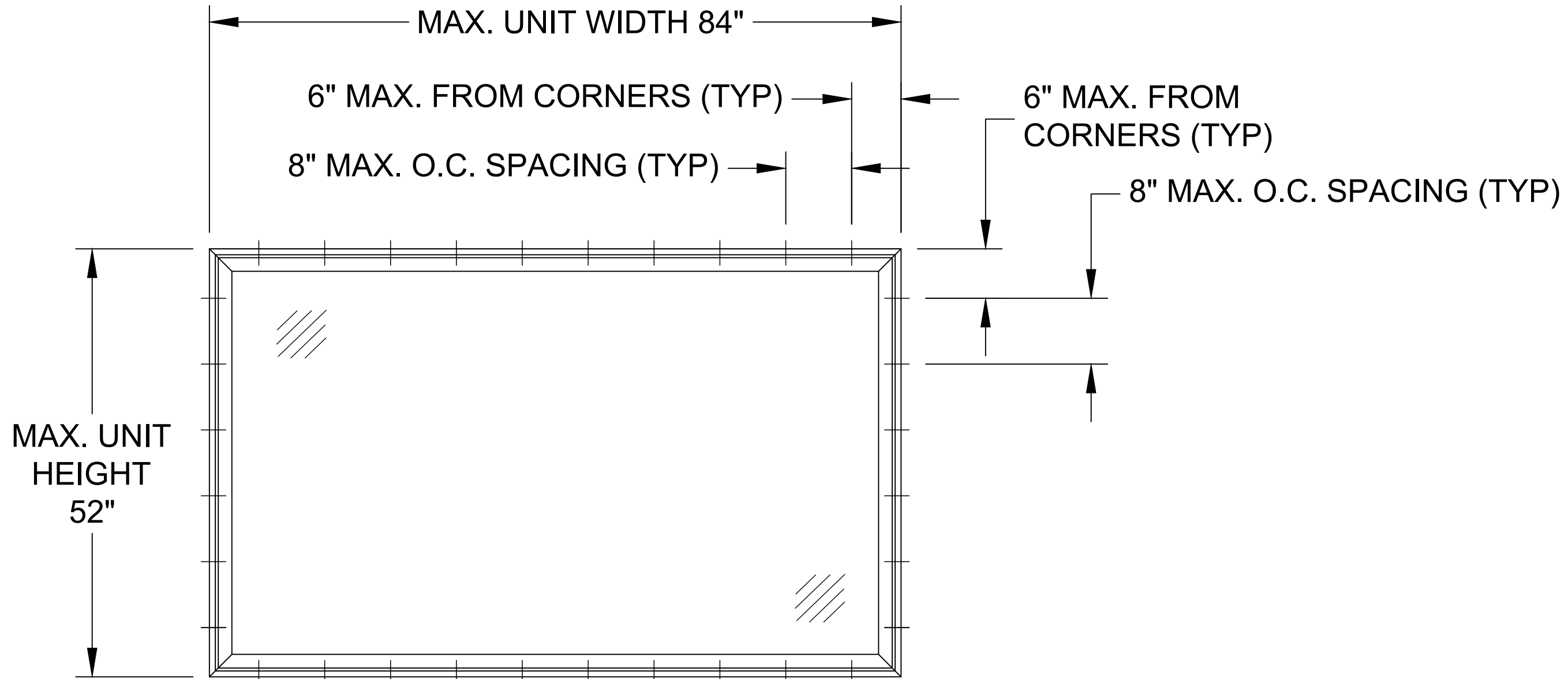

SERIES 3000/4000 VINYL FIXED WINDOW
EXTERIOR VIEW

DESIGN PRESSURE RATING (PSF)	IMPACT RATING
+70.0/-70.0	NONE

NOTES:

1. MAXIMUM D.L.O.: 79" X 47"

PROJECT #417-0906

REGENCY PLUS, INC.
2000 LOCUST GAP HIGHWAY
MT. CARMEL, PA 17851

TITLE: SERIES 3000/4000 VINYL FIXED WINDOW
ELEVATION AND ANCHORING

PREPARED BY:



Robert J. Amoruso, P.E.
Florida P.E. No. 49752

DRAWN BY: RJA
SCALE: N.T.S.
REV: A

DATE: 1/11/18
DRAWING NO: RPLS0053
SHEET: 2 OF 3

REV	DESCRIPTION	DATE	BY
A	UPDATE TO CURRENT EDITION OF FBC	1/22/18	RJA

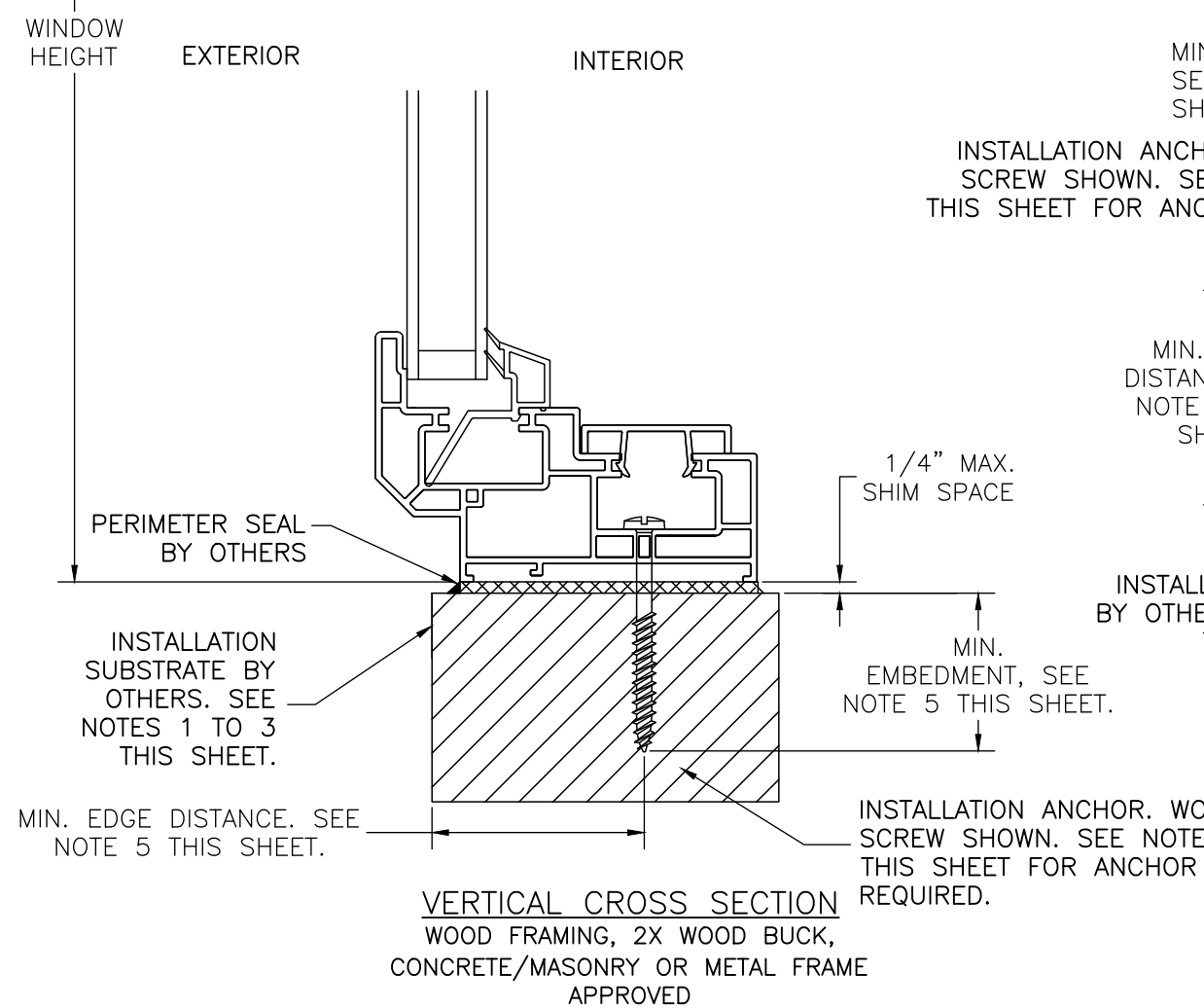
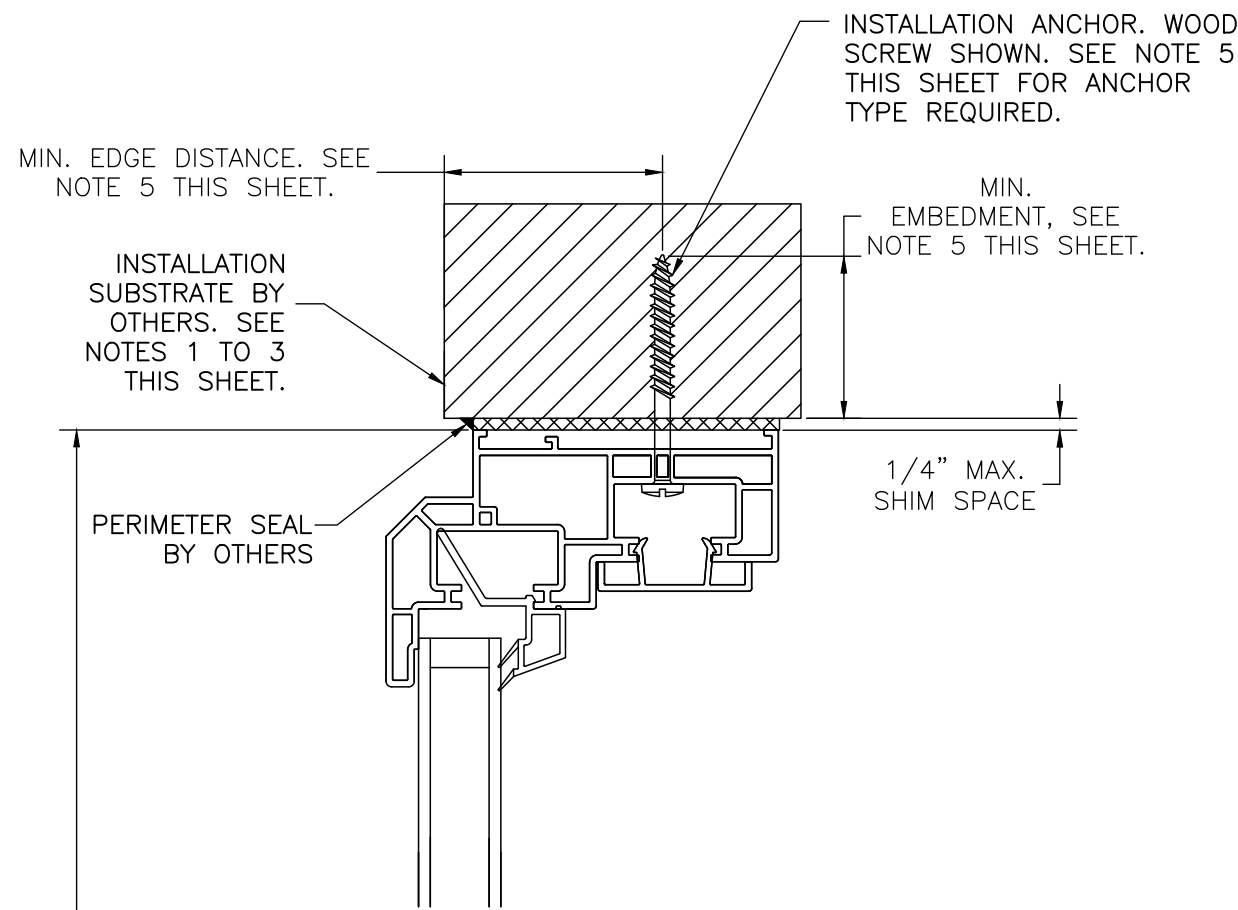

INSTALLATION NOTES:

1. APPROVED INSTALLATION SUBSTRATES INCLUDE THE FOLLOWING:
 - 1.1. WOOD FRAMING
 - 1.2. STEEL STUD FRAMING AND
 - 1.3. CONCRETE AND/OR MASONRY
2. SUBSTRATE OPENING TO BE DESIGNED AND ANCHORED TO PROPERLY TRANSFER ALL LOADS TO STRUCTURE. FRAMING AND CONCRETE/MASONRY OPENING IS THE RESPONSIBILITY OF THE ARCHITECT OR ENGINEER OF RECORD.
3. 1X BUCK OVER CONCRETE/MASONRY IS OPTIONAL. WHERE 1X BUCK IS NOT USED, DISSIMILAR MATERIALS MUST BE SEPARATED WITH APPROVED COATING OR MEMBRANE. SELECTION OF COATING OR MEMBRANE IS THE RESPONSIBILITY OF THE ARCHITECT OR ENGINEER OF RECORD.
4. SHIM AS REQUIRED AT EACH INSTALLATION ANCHOR WITH LOAD BEARING SHIM. SHIM WHERE SPACE OF 1/16" OR GREATER OCCURS. MAXIMUM ALLOWABLE SHIM STACK TO BE 1/4".
5. SUBSTRATE ANCHORING METHODS:
 - 5.1. FOR ANCHORING INTO CONCRETE/MASONRY USE 3/16" HEX HEAD TAPCONS WITH SUFFICIENT LENGTH TO ACHIEVE A 1 1/2" MINIMUM EMBEDMENT INTO CONCRETE WITH 1 1/8" MINIMUM EDGE DISTANCE AND 1" MINIMUM EMBEDMENT INTO MASONRY WITH 2" MINIMUM EDGE DISTANCE. LOCATE ANCHORS AS SHOWN IN ELEVATIONS AND INSTALLATION DETAILS. ANCHOR LOCATIONS HAVE +/- 1" TOLERANCE.
 - 5.2. FOR ANCHORING INTO WOOD FRAMING OR 2X BUCK USE #10 PAN HEAD WOOD SCREWS WITH SUFFICIENT LENGTH TO ACHIEVE A 1 3/8" MINIMUM EMBEDMENT INTO SUBSTRATE WITH 3/4" MINIMUM EDGE DISTANCE. LOCATE ANCHORS AS SHOWN IN ELEVATIONS AND INSTALLATION DETAILS. ANCHOR LOCATIONS HAVE +/- 1" TOLERANCE.
 - 5.3. FOR ANCHORING INTO METAL STRUCTURE USE #10 PAN OR HEX HEAD SMS OR SELF DRILLING SCREWS WITH SUFFICIENT LENGTH TO ACHIEVE 3 THREADS MINIMUM BEYOND STRUCTURE INTERIOR WALL WITH 3/4" MINIMUM EDGE DISTANCE. LOCATE ANCHORS AS SHOWN IN ELEVATIONS AND INSTALLATION DETAILS. ANCHOR LOCATIONS HAVE +/- 1" TOLERANCE.
6. INTERIOR AND EXTERIOR FINISHES BY OTHERS. NOT SHOWN FOR CLARITY.
7. PERIMETER AND JOINT SEALANT BY OTHERS TO BE DESIGNED AND/OR SPECIFIED IN ACCORDANCE WITH ASTM E2112.

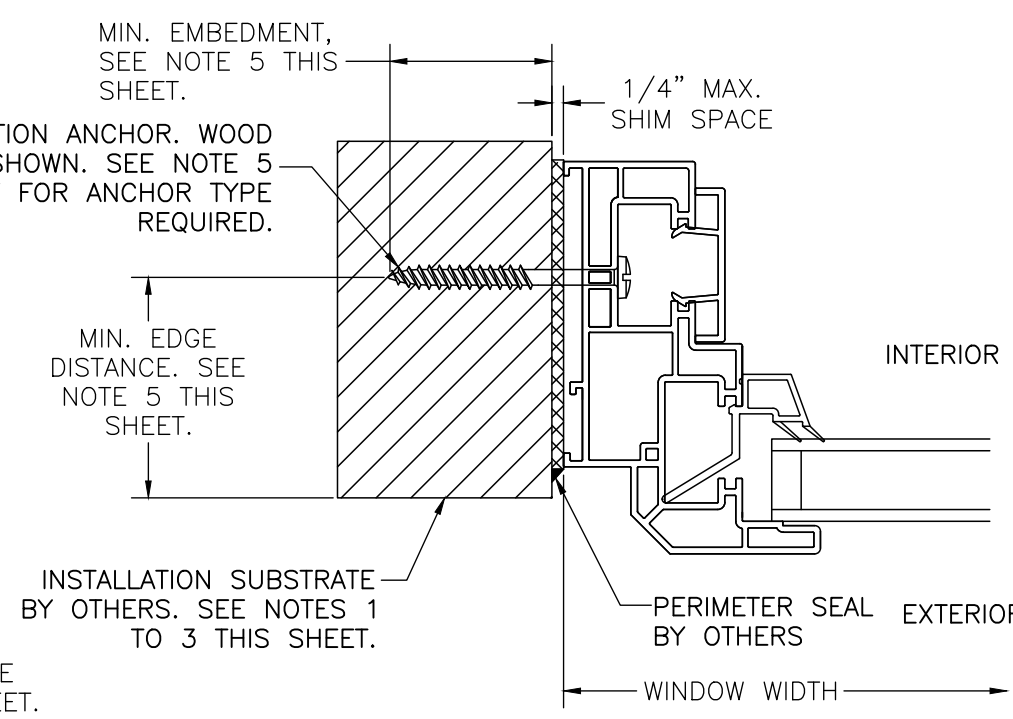

HORIZONTAL (JAMB) CROSS SECTION
 WOOD FRAMING, 2X WOOD BUCK,
 CONCRETE/MASONRY OR METAL FRAME
 APPROVED

VERTICAL CROSS SECTION
 WOOD FRAMING, 2X WOOD BUCK,
 CONCRETE/MASONRY OR METAL FRAME
 APPROVED

PROJECT #417-0906	DATE	1/22/18	BY	RJA
	DESCRIPTION	UPDATE TO CURRENT EDITION OF FBC	REV	A

REGENCY PLUS, INC.
 2000 LOCUST GAP HIGHWAY
 MT. CARMEL, PA 17851

TITLE: SERIES 3000/4000 VINYL FIXED WINDOW INSTALLATION DETAILS

DATE: 1/11/18
 DRAWING NO: RPLS0053
 SHEET: 3 OF 3

DRAWN BY: RJA
 SCALE: N.T.S.
 REV: A

Robert J. Amoruso, P.E.
 Florida P.E. No. 49752