



SIMPSON STRONG-TIE COMPANY INC.
5956 WEST LAS POSITAS BOULEVARD
PLEASANTON, CALIFORNIA 94588
(800) 925-5099

www.strongtie.com

SIMPSON STRONG-TIE NAIL HOLD-DOWNS (TENSION TIES)

CSI Division:

06—WOOD, PLASTICS AND COMPOSITES

CSI Section:

**06 05 23—Wood, Plastic, and Composite
Fastenings**

1.0 SCOPE OF EVALUATION

1.1 Compliance to the following codes & regulations:

- 2018 International Building Code® (IBC)
- 2018 International Residential Code® (IRC)
- 2015 International Building Code® (IBC)
- 2015 International Residential Code® (IRC)
- 2012 International Building Code® (IBC)
- 2012 International Residential Code® (IRC)
- 2009 International Building Code® (IBC)
- 2009 International Residential Code® (IRC)
- 2006 International Building Code® (IBC)
- 2006 International Residential Code® (IRC)

1.2 Evaluated in accordance with:

- ICC-ES AC155

1.3 Properties assessed:

- Structural

2.0 PRODUCT USE

Simpson Strong-Tie structural nail hold-down connectors (tension ties) are used as wood framing anchorage, such as to connect wood posts to concrete foundations or to connect an upper-story wood post to a lower-story supporting wood post, in accordance with 2018, 2015, 2012 and 2009 IBC Sections 2304.9.3, 2305.1, 2308.9.3.1, 2308.9.3.2 or 2006 IBC Sections 2304.9.3, 2305.1, 2305.3.2, 2305.3.7, 2305.3.8.2.4 and 2308.9.3.1 and [AWC SDPWS—2018](#), [AWC SDPWS—2015](#) or [AF&PA SDPWS—2008](#) or -2005, Special Design Provisions for Wind and Seismic Sections [4.3.6.4.2](#) and [4.3.6.1.2](#), and as anchorage of concrete and masonry walls to structural wood elements to provide lateral support for the walls as required by IBC Section 1604.8.

When regulated under the IRC, the hold-down connectors may also be used when an engineered design is submitted in accordance with IRC Section [R301.1.3](#).

Hold-down connectors may be used for anchoring concrete and masonry walls to structural wood elements and provide lateral support for the walls in accordance with 2018, 2015, 2012, and 2009 IRC Sections R606.12.2.3 and R611.9.1 or 2006 IRC Sections R606.12.2.2 and R611.8.2.1.

The DTT1 Hold-Down may be used to satisfy the deck lateral load connection requirement for a 750 pound (3336 N) hold-down tension device set forth in 2018 and 2015 IRC Section R507.2.4.

3.0 PRODUCT DESCRIPTION

3.1 Product information

3.1.1 LTT Nail Hold-downs: LTT Light Tension Ties are nailed hold-downs consisting of a steel strap component with 90 degree angle bend at the end and a base plate component installed in the bend, which eliminates the need for a washer to transfer load. These hold-downs have pre-punched holes for installation of fasteners used to connect the hold-down to the wood member. Bodies of the LTT19, LTT20B and LTTI31 are formed from No.16, No.12 and No.18 gage galvanized steel respectively. The base plate component for LTT's is No. 3 gage galvanized steel. [Figure 1](#) and [Table 1](#) of this report provide product dimensions, required fasteners and ASD allowable loads.

3.1.2 HTT Nail Hold-downs: HTT Heavy Tension Ties are single-piece formed nail hold-downs consisting of a steel strap with a four-ply formed seat element for an anchor bolt. The straight-strap portion has pre-punched holes for installation of fasteners used to connect the hold-down to the wood member. HTT is die-formed from No. 11 gage galvanized steel. Bearing plate BP5/8-2 is fabricated from 3/16 inch thickness steel and may be installed with HTT5 as a load transfer washer for additional capacity. [Figure 2](#) and [Table 1](#) of this report provide product dimensions, required fasteners and ASD allowable loads.

3.1.3 DTT1 Nail Hold-down: The DTT1 hold-down consists of a single-piece formed structural steel component with pre-punched holes for installation of fasteners used to connect the hold-down to the wood member. The DTT1 is formed from No. 14 gage galvanized steel.





The DTT1 may be used to anchor to the supporting structure using a 3/8-inch (9.5 mm) diameter machine bolt, anchor bolt, lag screw, or a 0.277-inch (7.0 mm) diameter Strong-Drive SDWH TIMBER-HEX HDG screw. A 3/8-inch (9.5 mm) standard cut washer is required when using a machine bolt, anchor bolt or lag screw. SDWH screws are manufactured with an integral washer and do not require a washer.

One steel, plain (flat), standard plate (W) washer conforming to [ASTM F844](#) and [ASME B18.22.1](#), Type A, with a 7/16-inch (11.1 mm) inner diameter, and a 1-inch (25.4 mm) outer diameter shall be installed between the nut and the seat of the DTT1 hold-down where required. The standard plate washer dimension tolerances shall be in accordance with ASTM B18.22.1. [Figure 3](#) and [Table 2](#) of this report contain product dimensions, required fasteners, and allowable loads.

3.2 Material information

3.2.1 Steel: LTT and HTT nail hold-downs described in this report are manufactured from [ASTM A653](#) SS Grade 33 galvanized steel with a minimum yield strength (F_y) of 33,000 psi (227 MPa) and a minimum ultimate tensile strength (F_u) of 45,000 psi (310 MPa). Load transfer base plates of the LTT series and bearing plate BP5/8-2 are fabricated from [ASTM A1011](#) SS Grade 33 steel having a minimum yield strength of 33,000 psi (227 MPa) and a minimum ultimate strength of 52,000 psi (359 MPa). Base metal thicknesses for the tension ties in this report are as follows:

THICKNESS (GAGE)	BASE METAL THICKNESS (inches)
3/16 inch	0.1775
No. 3	0.2285
No. 11	0.1105
No. 12	0.0975
No. 14	0.0721
No. 16	0.0555
No. 18	0.0445

For SI: 1 inch = 25.4 mm

Hold-downs have a minimum G90 zinc coating specification in accordance with ASTM A653. Some models may also be available with either a G185 zinc coating (denoted by model numbers ending in the letter Z) or with a batch hot-dipped galvanized coating with a minimum specified coating weight of 2.0 ounces of zinc per square foot of surface area (600 g/m²) total for both sides in accordance with [ASTM A123](#) (denoted by model numbers ending with the letters HDG). Model numbers in this report do not list the Z or HDG ending but the

information shown applies. Lumber treater or holder of this report (Simpson Strong-Tie) shall be contacted for recommendations on minimum corrosion resistance of steel connectors in contact with the specific proprietary preservative-treated or fire-retardant-treated lumber.

3.2.2 Wood: Wood members connected to hold-downs shall be either sawn lumber or engineered lumber. Sawn lumber shall have a minimum specific gravity of 0.50 and a maximum moisture content of 19 percent. Engineered lumber shall have a minimum equivalent specific gravity of 0.50 and a maximum moisture content of 16 percent. Minimum thickness (depth) of the wood members in the direction of the fastener penetration are shown in [Table 1](#) of this report and the required minimum width of the wood members is 3 1/2 inches (89 mm), except as noted.

3.2.3 Fasteners

3.2.3.1 Nails: Common nails used with connectors in this report shall comply with [ASTM F1667](#) and have the following minimum fastener dimensions and bending yield strengths (F_{yb}):

NAIL SIZE	SHANK DIAMETER (inches)	FASTENER LENGTH (inches)	F_{yb} (psi)
10d x 1 1/2	0.148	1 1/2	90,000
10d	0.148	3	90,000
16d x 2 1/2	0.162	2 1/2	90,000
16d	0.162	3 1/2	90,000

For SI: 1 inch = 25.4 mm, 1 psi = 6.895 kPa

3.2.3.2 Bolts: Machine bolts shall comply with [ASME Standard B18.2.1](#) and with [ASTM A307](#). Minimum bending yield strength (F_{yb}) of the bolt shall be 45,000 psi (310 MPa).

3.2.3.3 Threaded Anchor Rods: As a minimum, threaded steel anchor rods shall comply with [ASTM F1554](#) Grade 36.

3.2.3.4 Preservative-treated and fire-retardant-treated wood: Fasteners used in contact with preservative-treated or fire-retardant-treated lumber shall comply with 2018 2015 IBC Section 2304.10.5, 2012, 2009, and 2006 IBC Section 2304.9.5, 2018, 2015, 2012, and 2009 IRC Section R317.3, or 2006 IRC Section R319.3 as applicable. The lumber treater or report holder shall be contacted for recommendations on minimum corrosion resistance and connection capacities of fasteners used with the specific proprietary preservative-treated or fire-retardant-treated lumber.



3.2.3.5 Screws: The HTT5-3/4 Hold-down may be attached to wood with SD Series screws. The ICC-ES [ESR-3046](#) shall be referenced with respect to minimum requirements for installation, exposure, and contact with preservative-treated or fire-retardant treated lumber.

Strong-Drive SDWH TIMBER-HEX HDG screw with an integral washer may be used to anchor the DTT1 to a supporting wood member in accordance with IAPMO UES [ER-192](#).

Lag screws may be used to anchor the DTT1 to a supporting wood member. Lag screws shall be 3/8 inch (9.5 mm) diameter and comply with ANSI/ASME Standard B18.6.1.

4.0 DESIGN AND INSTALLATION

4.1 Design

4.1.1 Hold-Down Assembly: Allowable loads shown in [Table 1](#) of this report are for hold-down assemblies consisting of the following components: (1) hold-down device; (2) an anchor bolt/rod attached to the seat of the device; (3) a wood member having minimum specified dimensions and properties; (4) quantity and size of fasteners used to attach the hold-down device to the wood member; and, in some cases as noted (5) bearing plates or washers. Allowable loads shown in the product tables of this report are based on allowable stress design (ASD) and include the load duration factor (C_D) corresponding with the applicable loads in accordance with the ANSI/AWC [NDS-2018](#) ANSI/AWC [NDS-2015](#) or [-2012](#) or ANSI/AF&PA [NDS-2005](#), National Design Specification for Wood Construction. The assembly shall have an allowable strength equal to or exceeding the required strength of the assembly under the action of the ASD (Allowable Stress Design) load combinations referenced in the applicable code.

Where design load combinations include earthquake loads or effects, story drifts of the structure shall be determined in accordance with Section 12.8.6 of [ASCE 7](#) (ASCE 7-10 for 2018, 2015 and 2012 IBC) (ASCE 7-05 for 2009 and 2006 IBC) except for those structures analyzed using the Simplified Design Procedure pursuant to Section 12.14.

Deflection of a shear wall restrained from overturning by hold-downs installed in accordance with this report shall be determined in accordance with 2018, 2015 and 2012 IBC Section 2305.3, 2009 IBC Section 2305.1 or 2006 IBC Section 2305.3.1. Total deflection values, Δ_{all} and Δ_s , at ASD-level and strength-level forces, respectively, for hold-down assemblies shown in [Table 1](#) of this report, include all sources of hold-down device extension and rotation and anchor rod elongation where the length of the anchor rod is

a maximum of 4½ inches (152 mm). Contribution of the hold-down anchor rod elongation to the total elongation (deflection) of the hold-down assembly needs to be considered when the actual diameter, length or ASTM steel specification of the anchor rod differs from that described in this report.

Design of hold-downs used in series shall account for the cumulative deformation of all hold-downs (tie-downs) within said series.

Symbol Δ_s as used in this report refers to the symbol d_a in IBC Section 2305.3 and the symbol Δ_a in [AWC SDPWS—2015](#), or [ANSI/AF&PA SDPWS-2008](#) or [-2005](#) Section 4.3.2.

When hold-downs are fastened to wood having a moisture content greater than 19 percent for sawn lumber or 16 percent for engineered lumber, or where wet service is expected, allowable loads shown in [Table 1](#) of this report shall be adjusted by the wet service factor (C_m) specified in the ANSI/AWC [NDS-2018](#) ANSI/AWC NDS-2015 or 2012 or ANSI/AF&PA NDS-2005.

Tabulated allowable loads are for hold-downs connected to wood used under continuously dry interior conditions and where sustained temperatures are 100°F (37.8°C) or less.

When hold-downs are fastened to wood that will experience sustained exposure to temperatures exceeding 100°F (37.8°C), allowable loads shown in [Table 1](#) of this report shall be adjusted by the temperature factor (C_t) specified in the ANSI/AWC NDS-2015 or -2012 or ANSI/AF&PA NDS-2005.

The design of wood members fastened to the LTT and HTT hold-down (tie-down) device(s) shall consider combined stresses as follows:

Single shear: The wood member shall be checked for its allowable capacity at the critical net section for total combined stresses in accordance with the NDS, where applicable. Total combined stresses at the critical net section shall consider combined flexural bending due to hold-down (tie-down) eccentricity relative to the centroid of the connected wood member (M_{xx} and M_{yy}), and tension (T).

4.1.2 Anchorage to Concrete or Masonry: Design of anchorage to concrete or masonry structural members shall be determined by a structural design professional in accordance with Chapters 19 or 21 of the IBC, as applicable. The design shall address adequate embedment length and anchorage details, including edge and end distances.



4.2 Installation: Installation of the Simpson Strong-Tie hold-down connectors shall be in accordance with this evaluation report and the manufacturer's published installation instructions. In the event of a conflict between this report and the manufacturer's published installation instructions, the more restrictive governs.

4.3 Special Inspection

4.3.1 IBC: A statement of special inspection shall be prepared by the registered design professional in responsible charge and submitted to the building official for approval when required by 2018, 2015 and 2012 IBC Section 1704.3 or 2009 (2006) IBC Section 1705. A statement of responsibility shall be submitted by each responsible contractor to the code official for approval when required by 2018, 2015 and 2012 IBC Section 1704.4, 2009 IBC Section 1709 or 2006 IBC Section 1706.

4.3.2 Periodic special inspection shall be conducted when the hold-downs are components within the main wind-force-resisting system of structures constructed in areas listed in 2018, 2015 IBC Section 1705.11, 2012 IBC Section 1705.10, 2009 IBC Section 1706.1 or 2006 IBC Section 1705.4. Special inspection requirements do not apply to structures, or portions thereof, that qualify for an exception pursuant to 2018, 2015 IBC Sections 1704.2 or 1705.11.1, 2012 IBC Sections 1704.2, or 1705.10.1, 2009 IBC Sections 1704.1, 1704.4, 1706.2 or 1706.3 or 2006 IBC Sections 1704.1 or 1704.4.

4.3.3 Periodic special inspection for seismic resistance shall be conducted in accordance with 2018, 2015 IBC Section 1705.12, 2012 IBC Section 1705.11 or 2009 (2006) Section 1707 where required. Special inspection requirements for seismic resistance do not apply to structures, or portions thereof, that qualify for an exception pursuant to 2018, 2015 IBC Sections 1704.2 and 1705.12, 2012 IBC Sections 1704.2, 1705.11, and 1705.11.2 or 2009 (2006) IBC Sections 1704.1, 1705.3, 1707.3 or 1707.4.

4.3.4 For installations under the IRC, special inspection is not normally required. However, when an engineered design is submitted or required pursuant to 2018, 2015, 2012 (2009) (2006) IRC Section 301.1.3, periodic special inspection requirements and exemptions are as stated in Sections 4.3.1, 4.3.2 and 4.3.3 of this report as applicable.

5.0 LIMITATIONS

Simpson Strong-Tie nail hold-down connectors described in this report comply with, or are suitable alternatives to, what is specified in those codes listed in Section 1.0 of this report subject to the following conditions:

5.1 Hold-downs shall be manufactured, identified and installed in accordance with this report and the manufacturer's published installation instructions. Installation instructions shall be available at the jobsite at all times during installation. Where conflicts occur, the more restrictive shall govern.

5.2 Calculations, drawings, and design details showing compliance with this report shall be submitted to the building official. The calculations drawings, and design details shall be prepared by a registered design professional where required by the statutes of the jurisdiction in which the project is to be constructed.

5.3 Adjustment factors noted in Section 4.1 of this report and the applicable codes shall be considered where applicable.

5.4 Connected wood members and fasteners shall comply, respectively, with Sections 3.2.2 and 3.2.3 of this report.

5.5 The use of hold-downs (tie-downs) in contact with chemically treated preservative wood is subject to the approval of the code official, since the effects of corrosion of metal in contact with chemically treated wood on the structural performance of the devices is outside the scope of this report. Section 3.2.1 of this report provides additional information. Use of fasteners with preservative-or-fire-retardant-treated lumber shall be in accordance with Section 3.2.3 of this report.

5.6 Anchorage to concrete or masonry structural members shall be provided in accordance with Section 4.1.2 of this report.

5.7 No further duration of load increase for wind or earthquake loading shall be allowed.

5.8 For compliance with the 2018, 2015, 2012, or 2009 IBC, a statement of special inspection shall be prepared by the registered design professional in responsible charge, and submitted to the code official for approval, where required by 2018, 2015 and 2012 IBC Section 1704.3 or Section 1705 of the 2009 IBC. For compliance with the 2006 IBC, a quality assurance plan shall be submitted to the code official for approval, where required by Sections 1705 or 1706 of the 2006 IBC.

5.9 Special inspections for seismic or wind resistance shall be conducted as required, and in accordance with the appropriate sections of Chapter 17 of the IBC and Sections 4.3.2 and 4.3.3 of this report.

5.10 Special inspections for anchor bolts in concrete or masonry shall be conducted in accordance with Sections 1705.3 or 1705.4 of the 2018 (2015) and 2012 IBC, or



Sections 1704.4 or 1704.5 of the 2009 and 2006 IBC.

6.0 SUBSTANTIATING DATA

Data in accordance with ICC-ES Acceptance Criteria for Hold-Downs (Tie-Downs) Attached to Wood Members (AC155), approved May 2015, editorially revised January 2018, inclusive of tests and calculations. Test reports are from laboratories in compliance with [ISO/IEC 17025](#).

7.0 IDENTIFICATION

Products described in this report are identified with a die-stamped label indicating the name of the manufacturer (Simpson Strong-Tie), the model number and the number of the index evaluation report ([ER-102](#)) that identifies products recognized in this report.

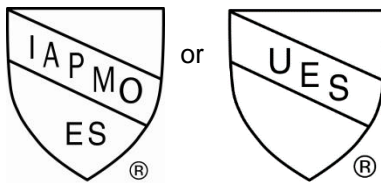

IAPMO UES ER-130

Brian Gerber, P.E., S.E.
Vice President, Technical Operations
Uniform Evaluation Service

Richard Beck, PE, CBO, MCP
Vice President, Uniform Evaluation Service

GP Russ Chaney
CEO, The IAPMO Group

For additional information about this evaluation report please visit www.uniform-es.org or email at info@uniform-es.org

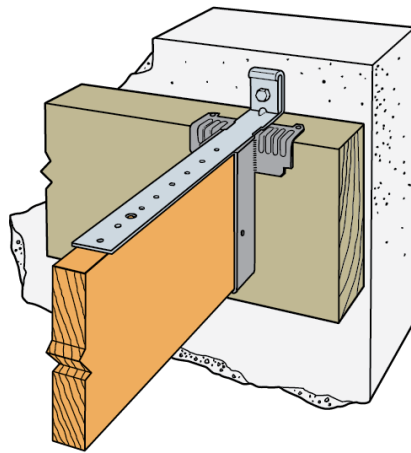
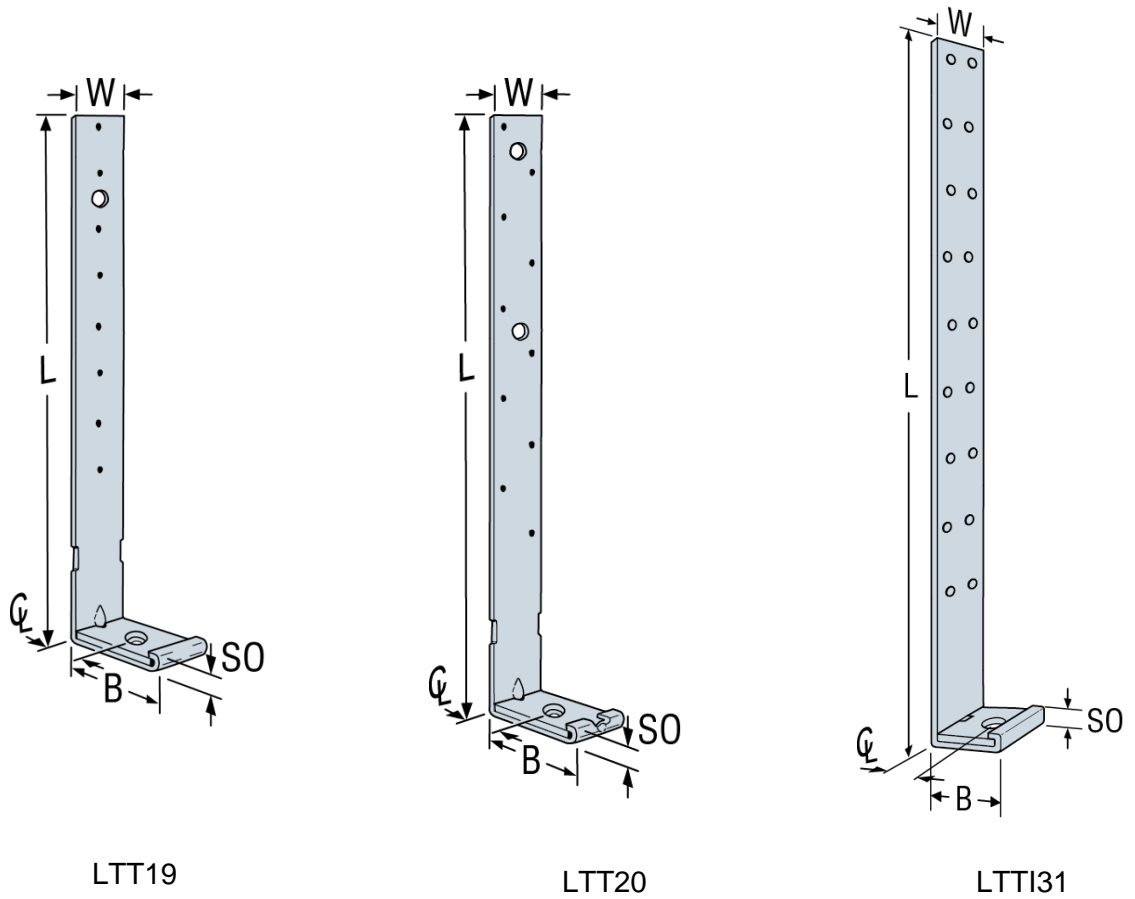

TABLE 1: ALLOWABLE LOADS FOR THE LTT AND HTT NAIL HOLD-DOWNS (TENSION TIES) ASSEMBLIES

MODEL NO.	DIMENSIONS					FASTENERS		MIN. WOOD MEMBER THICKNESS ¹ (inches)	ALLOWABLE TENSION LOADS ^{2,3,4,5} , P _{all} (lbs) C _D = 1.6	DISPLACEMENT Δ AT MAXIMUM LOAD ^{6,7} (in.)	
	W	L	CL	B	SO	ANCHOR BOLT	FASTENER QUANTITY			Δ _{all}	Δ _s
LTT19 ⁽⁸⁾	1¾	19½	1¾	2¾	5/16	½, 5/8 or ¾	8-10dx1½	3	1310	0.180	0.248
							8-10d	3	1340	0.157	0.233
LTT20B ⁽⁸⁾	2	19¾	1½	3¾	5/16	½, 5/8 or ¾	10-10dx1½	3	1355	0.195	0.250
							10-10d	3	1500	0.185	0.250
							2-½" Bolt ⁽⁹⁾	3	1625	0.183	0.250
LTTI31	3¾	31	1¾	2¾	¼	5/8	18-10dx1½	3	1350	0.193	0.250
HTT4	2½	12¾	1¾	2	7/16	5/8	18-10dx1½	3	3610	0.086	0.135
							18-16dx2½ ⁽¹¹⁾	3	4235	0.123	0.201
HTT5	2½	16	1¾	2	7/16	5/8	26-10dx1½	3	4350	0.120	0.209
							26-10d	3	4670	0.116	0.234
							26-16dx2½ ⁽¹¹⁾	3	5090 ⁽¹⁰⁾	0.135	0.250
HTT5-3/4	2½	16	1¾	2	7/16	¾	26-10dx1½	1½ ⁽¹²⁾	4065	0.103	0.190
							26-SD10112	1½ ⁽¹³⁾	4830	0.100	0.159
							26-16dx2½ ⁽¹¹⁾	3	5090	0.121	0.197

SI: 1 inch = 25.4 mm, 1 lbs = 4.45 N.

- Tabulated allowable loads are for a hold-down assembly consisting of the hold-down device attached to wood structural with a certain minimum wood thickness, or a multiple members attached together as shown in this table (Table 1). The minimum width of the wood members shall be 3½ inches, except as noted. The allowable load values of the hold-down (tie-down) device are a measure of steel strength of the device when tested on a steel jig with a safety factor of 2.5 applied to the (lowest or average, whichever is applicable) maximum test load.
- Allowable loads for the hold-down assemblies are based on allowable stress design (ASD) and include the load duration factor, C_D = 1.6, corresponding with wind/earthquake loading in accordance with the NDS. No further increase is allowed. Reduce where other load durations govern. The allowable strength values are applicable for designs complying with Sections 12.10 and 12.11.2 of [ASCE 7](#).
- When using the basic load combinations in accordance 2018 (2015) (2012) (2009) (2006) IBC Section 1605.3.1, the tabulated allowable loads for the hold-down assembly shall not be increased for wind or earthquake loading. When using the alternative basic load combinations in 2018 (2015) (2012) (2006) IBC Section 1605.3.2 that includes wind or earthquake loads, the tabulated allowable loads for the hold-down assembly shall not be increased by 33½ percent, nor shall the alternative basic load combinations be reduced by a factor of 0.75.
- Anchorage to concrete or masonry shall be determined in accordance with Section 4.1.2 of this report.
- Tabulated allowable (ASD) tension loads shall be multiplied by 1.4 to obtain the strength-level resistance loads associated with the tabulated Δ_s deformations.
- Tabulated displacement values, Δ_{all} and Δ_s, for hold-down assemblies include all sources of hold-down assembly elongation, such as fastener slip, hold-down device extension and rotation, and anchor rod elongation, at ASD-level and strength level forces respectively.
- Elongation of the hold-down anchor rod shall be calculated when the ASTM steel specification of the anchor rod differs from that described in the Section 3.2.4 of this report or the actual unbraced length is greater than 4½ inches. In lieu of calculating the elongation of the hold-down anchor rod for hold-downs raised 4½ to 18 inches above the concrete, it is permitted to add an additional anchor rod elongation of 0.01 inches to the tabulated hold-down deflection.
- If a ½ or ¾ inch diameter anchor bolt is used for the LTT19 or LTT20B, add a standard cut washer to the seat. No additional washer is required for a ¾ inch diameter anchor bolt. Table 1 provides specified anchor bolt sizes.
- Wood member bolts shall be in accordance with Section 3.2.3.2 of this report.
- Allowable tension load for HTT5 with bearing washer BP5/8-2 is 5295 lbs. (Δ_{all} = 0.126, Δ_s = 0.179).
- 16d common nails are permitted to substitute for 16dx2½ inch long nails.
- The minimum width of the wood structural member shall be 5½ inches (2x6 nominal).
- The minimum width of the wood structural member shall be 7¼ inches (2x8 nominal).



LTT19 Horizontal Installation
(LTT20B Similar)

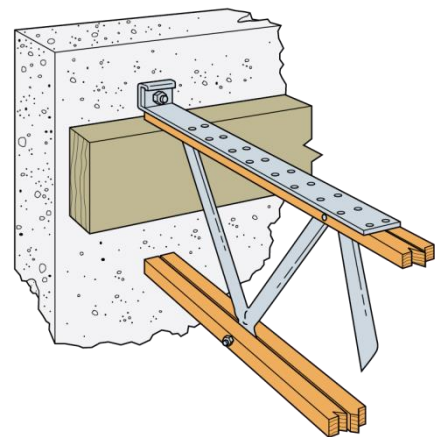

LTTI31 Horizontal Installation

Figure 1 – LTT Nail Hold-Downs

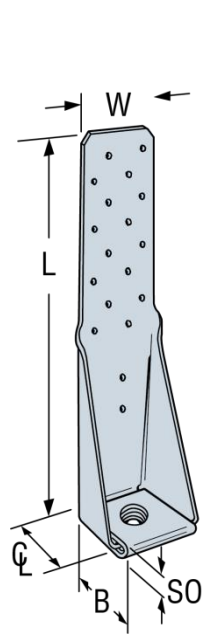

HTT4

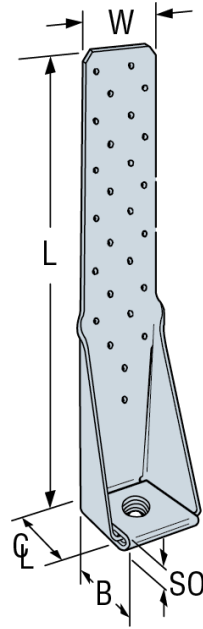

HTT5
(HTT5-3/4 Similar)

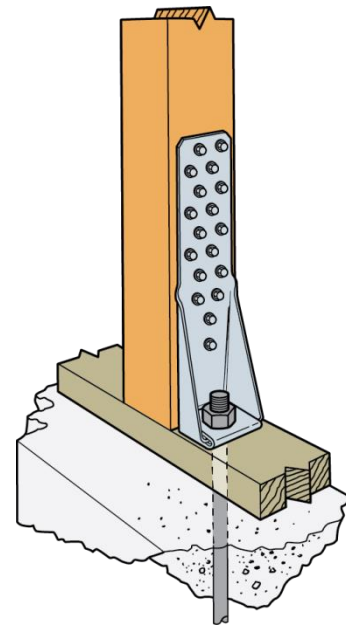

HTT5 Vertical
Typical Installation
(HTT4 Similar)

Figure 2 – HTT Nail Hold-Downs

TABLE 2: ALLOWABLE LOADS FOR THE DTT1 HOLD-DOWN ^{1,2,3,12}

MODEL NO.	FASTENERS		MIN WOOD MEMBER THK. (in.)	ALLOWABLE TENSION LOADS, P _{all} (lbs.)				DISPLACEMENT, Δ, AT MAXIMUM LOAD ^{7,8,9} (in.)	
	ANCHOR DIAMETER & TYPE ⁴	FASTENER QUANTITY		DRY ⁵ , C _D = 1.0		WET ⁶ , C _D = 0.7		Δ _{all}	Δ _s
				C _D = 1.0	C _D = 1.6	C _D = 1.0	C _D = 1.6		
DTT1Z	3/8" ¹⁰ or SDWH ¹¹	6-SD9112	1 1/2	840	840	720	840	0.170	0.250
		6-10dx1 1/2	1 1/2	755	910 ¹¹	530	795	0.167	0.250
		8-10dx1 1/2	1 1/2	910 ¹¹	910 ¹¹	705	910 ¹¹	0.167	0.250

SI: 1 inch = 25.4 mm, 1 lb. = 4.45 N.

1. Tabulated allowable loads are for a hold-down assembly consisting of the hold-down device attached to 1 1/2-inch thick wood structural member with the fasteners noted in Table 2.
2. The allowable loads for the hold-down assemblies are based on allowable stress design (ASD) and include the load duration factors, C_D, corresponding with a normal duration of load (C_D = 1.0) and wind/earthquake loading (C_D = 1.6) in accordance with the NDS. No further increase is allowed. Where other load durations govern, the values under C_D = 1.0 shall be adjusted accordingly.
3. When using the basic load combinations in accordance with 2018 (2015) (2012) (2009) (2006) IBC Section 1605.3.1, the tabulated allowable loads for the hold-down assembly shall not be increased for wind or earthquake loading. When using the alternate basic load combinations in 2018 (2015) (2012) (2009) (2006) IBC Section 1605.3.2 that includes wind or earthquake loads, the tabulated allowable loads for the hold-down assembly shall not be increased by 33 1/3 percent, nor shall the alternative basic load combinations be reduced by a factor of 0.75.
4. Anchorage to concrete or masonry shall be determined in accordance with Section 4.1.2 of this report.
5. Dry values are applicable to installations into wood with a moisture content that does not exceed 19 percent.
6. Wet values are applicable to installations into wood with a moisture content greater than 19 percent at the time of installation or in service. Values include a NDS wet service factor for the fasteners (C_M = 0.7).
7. The tabulated allowable (ASD) tension loads shall be multiplied by 1.4 to obtain the strength-level resistance loads associated with the tabulated Δ_s deformations.
8. Tabulated displacement values, Δ_{all} and Δ_s, for hold-down assemblies include all sources of hold-down assembly elongation, such as fastener slip, hold-down device extension and rotation, and anchor rod elongation, at ASD-level and strength level forces respectively.
9. Elongation of the hold-down anchor rod shall be calculated when the actual unbraced length is greater than 2.5 inches, or ASTM steel specification of the anchor rod differs from that described in the Section 3.2.4 of this report.
10. A 3/8 inch diameter round washer is required when using a 3/8 inch diameter machine bolt, anchor bolt or lag screw.
11. The DTT1 installed with the Strong-Drive SDWH Timber-Hex HDG screw achieves the lesser of the table load or 855 lbs. The SDWH Timber-Hex HDG screw with a 3 inch minimum thread penetration into a supporting wood member with a minimum specific gravity of 0.50 has an allowable withdrawal load of 1,225 pounds, which includes a load duration factor of 1.6.
12. Tabulated values are for connectors installed flush with the end of the framing member or installed away from the end.

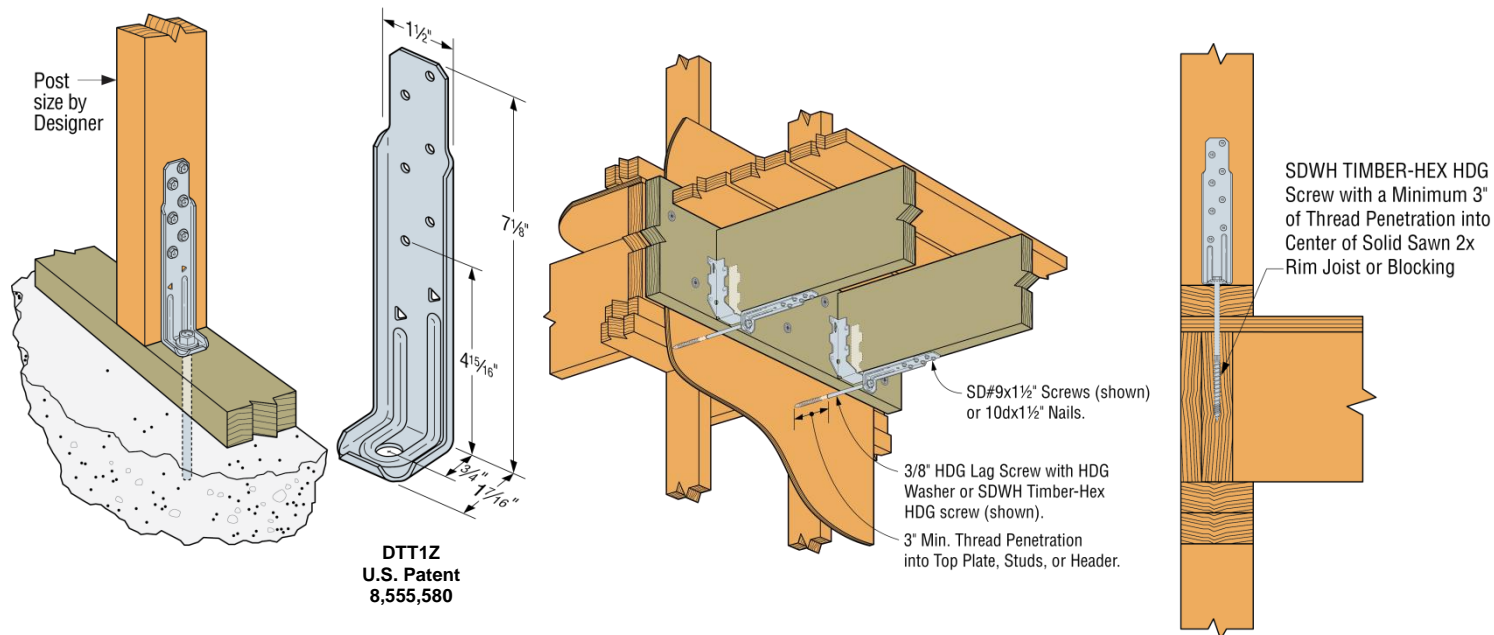

Figure 3 – DTT1 Nail Hold-Downs



FLORIDA SUPPLEMENT

EVALUATION SUBJECT: SIMPSON STRONG-TIE NAIL HOLD-DOWNS (TENSION TIES)

REPORT HOLDER:
Simpson Strong-Tie Company Inc.
5956 West Las Positas Boulevard
Pleasanton, California 94588
(800) 925-5099
www.strongtie.com

CSI Division: 06—WOOD, PLASTICS AND COMPOSITES
CSI Section: 06 05 23—Wood, Plastic, and Composite Fastenings

1.0 RECOGNITION

Simpson Strong-Tie structural nail hold-down connectors (tension ties) have been evaluated for structural performance properties, subject to the requirements in ER-130 and this supplemental report for compliance with the following codes and regulations:

- 2020 and 2017 Florida Building Code, Building (FBC–Building)
- 2020 and 2017 Florida Building Code, Residential (FBC–Residential)

2.0 LIMITATIONS

Simpson Strong-Tie structural nail hold-down connectors (tension ties) described in IAPMO UES ER-130 complies with the 2020 and 2017 FBC–Building and the 2020 and 2017 FBC–Residential, subject to the following limitations:

1. The design and installation of the Simpson Strong-Tie® structural angles, clips shall be in accordance with the 2018 or 2015 International Building Code and the 2018 or 2015 International Residential Code as noted in ER-130.
2. Load combinations shall be in accordance with Sections 1605.2 or 1605.3 of the FBC–Building, as applicable.
3. Design wind loads shall be in accordance with Section 1609.5 of the FBC–Building or Section R301.2.1.1 of the FBC–Residential, as applicable, and Section 1620

of the FBC–Building where used in High-velocity Hurricane Zones (HVHZ)

4. Use of Simpson Strong-Tie® structural nail hold-down connectors (tension ties) recognized in this report complies with the High-velocity Hurricane Zone (HVHZ) provisions set forth in Sections 2122.7 of the FBC–Building. Where used in accordance with Section 2122.7.2 of FBC–Building, the connectors shall be designed to provide positive direct connection to resist the horizontal forces as required in Section 1620 (HVHZ) of the FBC–Building or 200 pounds per lineal foot (2919 N/m), whichever is greater, in accordance with FBC–Building Section 2122.7.3.
5. Use of Simpson Strong-Tie® structural nail hold-down connectors (tension ties) recognized in this supplement complies with the High-velocity Hurricane Zone (HVHZ) provisions set forth in Sections 2324.2 of the FBC–Building. Where used in accordance with Section 2321.6 of FBC–Building, the structural angles, clips, and ties shall be designed to resist the uplift forces as required in Section 1620 (HVHZ) of the FBC–Building or 700 pounds (3114 N), whichever is greater, in accordance with FBC–Building Section 2321.7.
6. Simpson Strong-Tie structural nail hold-down connectors (tension ties) shall be manufactured, identified and installed in accordance with ER-130 and the manufacturer’s published installation instructions. A copy of the installation instructions shall be available at the job site continuously during installation. If there is a conflict between this report and the manufacturer’s published installation instructions, the more restrictive prevails.

For products falling under Florida Rule 61G20-2 verification that the report holder’s quality assurance program is audited by a quality assurance entity approved by the Florida Building Commission (or the building official when the report holder does not possess an approval by the Commission), to provide oversight and determine that the products are being manufactured as described in this evaluation report to establish continual product performance is required.

This supplement expires concurrently with ER-130.

For additional information about this evaluation report please visit www.uniform-es.org or email us at info@uniform-es.org