

REVISIONS			
REV	DESCRIPTION	DATE	APPROVED
L	ADDED COMPOSITE FRAME	09/08/2021	R.L.

NOTES:

- THE PRODUCT SHOWN HEREIN IS DESIGNED AND MANUFACTURED TO COMPLY WITH REQUIREMENTS OF THE FLORIDA BUILDING CODE.
- WOOD FRAMING, METAL STRUCTURE AND MASONRY OPENING TO BE DESIGNED AND ANCHORED TO PROPERLY TRANSFER ALL LOADS TO STRUCTURE. FRAMING AND MASONRY OPENING IS THE RESPONSIBILITY OF THE ARCHITECT OR ENGINEER OF RECORD.
- 1X BUCK OVER MASONRY/CONCRETE IS OPTIONAL. WHERE 1X BUCK IS NOT USED DISSIMILAR MATERIALS MUST BE SEPARATED WITH APPROVED COATING OR MEMBRANE. SELECTION OF COATING OR MEMBRANE IS THE RESPONSIBILITY OF THE ARCHITECT OR ENGINEER OF RECORD.
- ALLOWABLE STRESS INCREASE OF 1/3 WAS NOT USED IN THE DESIGN OF THE PRODUCT SHOWN HEREIN. WIND LOAD DURATION FACTOR $C_d=1.6$ WAS USED FOR WOOD ANCHOR CALCULATIONS.
- FRAME MATERIAL: WOOD WITH $G=.46$ MINIMUM SPECIFIC GRAVITY, OR FRAMESAVER, OR FUSION FRAME.
DOOR PANEL MATERIAL: 20 GA. STEEL WITH 17GA. STEEL OR .0938" FIBERGLASS TOP AND BOTTOM RAIL, SEE SHEET 17 FOR PANEL OPTIONS.
SIDELITES AND TRANSOM ARE DIRECT SET GLASS.
- UNITS MUST BE GLAZED PER ASTM E1300, WITH SAFETY GLAZING.
- APPROVED IMPACT PROTECTIVE SYSTEM IS REQUIRED FOR THIS PRODUCT IN WIND BORNE DEBRIS REGIONS.
- SHIM AS REQUIRED AT EACH INSTALLATION ANCHOR WITH LOAD BEARING SHIM. SHIM WHERE SPACE OF 1/16" OR GREATER OCCURS. MAXIMUM ALLOWABLE SHIM STACK TO BE 1/4".
- FOR ANCHORING INTO WOOD FRAMING OR 2X BUCK USE #10 WOOD SCREWS WITH SUFFICIENT LENGTH TO ACHIEVE A 1 3/8" MINIMUM EMBEDMENT INTO SUBSTRATE. LOCATE ANCHORS AS SHOWN IN ELEVATIONS AND INSTALLATION DETAILS.
- FOR ANCHORING INTO MASONRY/CONCRETE USE 3/16" TAPCONS WITH SUFFICIENT LENGTH TO ACHIEVE A 1 3/4" MINIMUM EMBEDMENT INTO SUBSTRATE WITH 2" MINIMUM EDGE DISTANCE. LOCATE ANCHORS AS SHOWN IN ELEVATIONS AND INSTALLATION DETAILS.
- FOR ANCHORING INTO METAL STRUCTURE USE #10 SMS OR SELF DRILLING SCREWS WITH SUFFICIENT LENGTH TO ACHIEVE 3 THREADS MINIMUM BEYOND STRUCTURE INTERIOR WALL. LOCATE ANCHORS AS SHOWN IN ELEVATIONS AND INSTALLATION DETAILS.
- ALL FASTENERS TO BE CORROSION RESISTANT.
- INSTALLATION ANCHORS SHALL BE INSTALLED IN ACCORDANCE WITH ANCHOR MANUFACTURER'S INSTALLATION INSTRUCTIONS AND ANCHORS SHALL NOT BE USED IN SUBSTRATES WITH STRENGTHS LESS THAN THE MINIMUM STRENGTH SPECIFIED BELOW:
 - WOOD – MINIMUM SPECIFIC GRAVITY OF $G=0.42$
 - CONCRETE – MINIMUM COMPRESSIVE STRENGTH OF 3,192 PSI.
 - MASONRY – GROUT FILLED STRENGTH CONFORMANCE TO ASTM C-90, GRADE N, TYPE 1 (OR GREATER).
 - METAL STRUCTURE: STEEL 18GA, 33KSI OR ALUMINUM 6063-T5 .048" THICK MINIMUM
- UNITS MAY BE INSTALLED WITH EITHER SCHLAGE F-SERIES DOOR KNOB AND B-SERIES OR F-SERIES DEADBOLT OR EMTEK RESIDENTIAL GRADE DOOR HANDLE ASSEMBLY OR MULTI-POINT LOCK HANDLE ASSEMBLY BY TRILENNIUM, SEE HARDWARE SCHEDULE SHEET 3 FOR APPROVED HARDWARE.

TABLE OF CONTENTS	
SHEET NO.	DESCRIPTION
1	NOTES
2 – 3	ELEVATION
4	ADDITIONAL CONFIGURATIONS
5 – 7	ANCHORING LAYOUTS
8 – 15	INSTALLATION DETAILS
16 – 21	COMPONENTS AND DETAILS

PROVIA, LLC.
2150 STATE ROUTE 39 WEST
SUGARCREEK, OH 44681

20GA. STEEL IS OR OS DOOR W/ AND W/OUT
14" SIDELITES AND TRANSOM
NOTES

DRAWN: TJH	DWG NO. 08-00708	REV L
SCALE NTS	DATE 03/17/09	SHEET 1 OF 21

L. ROBERTO LOMAS P.E.
1432 WOODFORD RD LEWISVILLE, NC 27023
434-688-0609 rllomas@rlomaspe.com

SIGNED: 09/09/2021

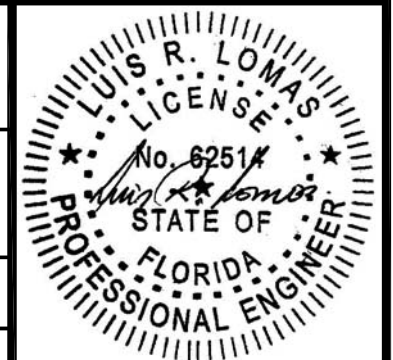

Luis R. Lomas P.E.
FL No.: 62514

REVISIONS			
REV	DESCRIPTION	DATE	APPROVED
L	ADDED COMPOSITE FRAME	09/08/2021	R.L.

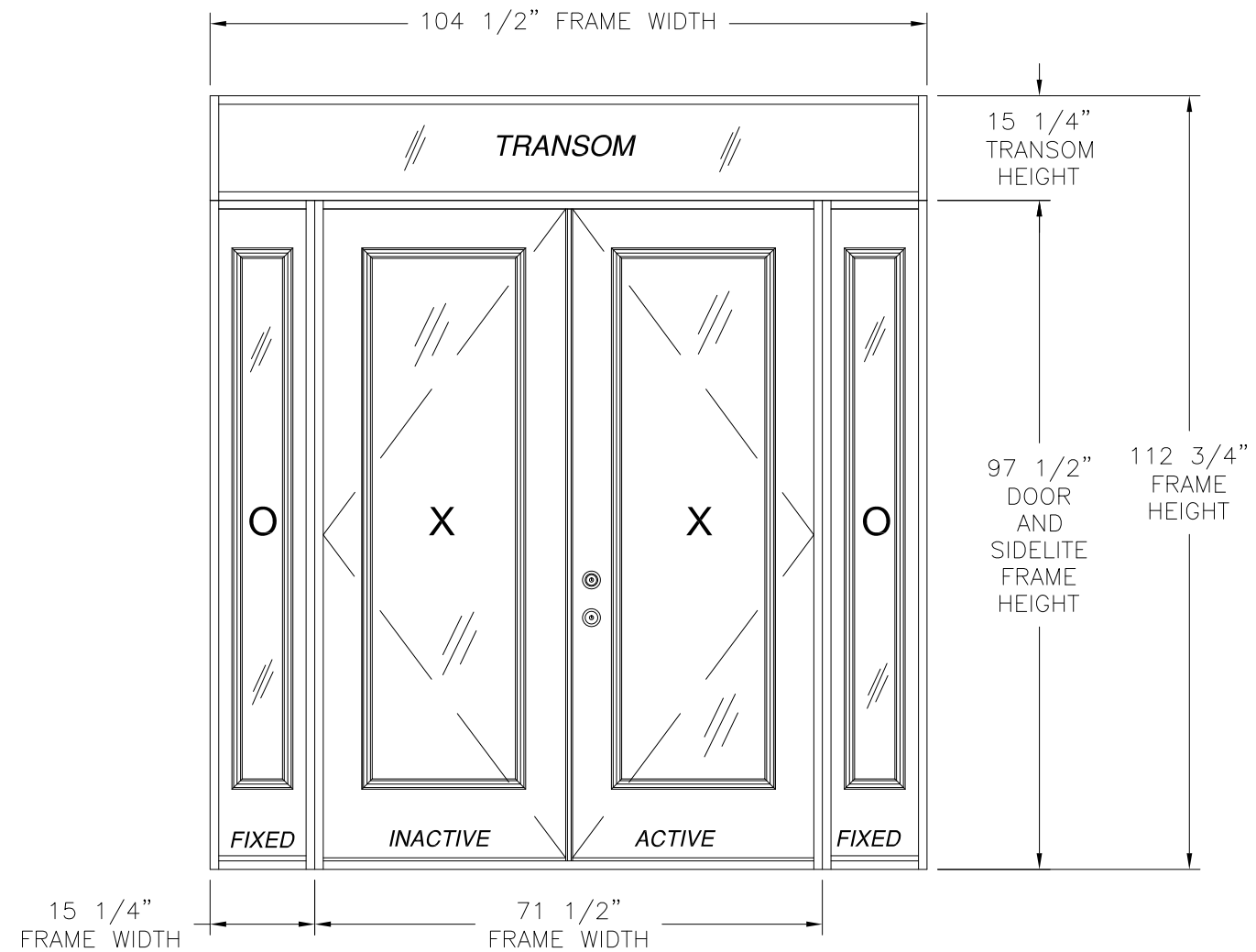

20GA STEEL OS DOUBLE DOOR W/ SIDELITES AND TRANSOM
EXTERIOR VIEW

DESIGN PRESSURE RATING	IMPACT RATING
+45.0PSF / -55.0PSF	NONE
THIS SYSTEM WAS NOT TESTED FOR WATER INFILTRATION AND IS TO BE INSTALLED ONLY WHERE THE WATER REQUIREMENT IS NOT NEEDED	

FOR ADDITIONAL APPROVED CONFIGURATIONS SEE SHEET 4.
35 3/4" x 94 15/16" PANEL SIZE SHOWN. OTHER SIZES ARE APPROVED AS LONG AS INDIVIDUAL PANEL AREA DOES NOT EXCEED 23.56 FT²

- NOTES:
1. DOOR PANEL SIZE: 35 3/4" X 94 15/16"
 2. SIDELITE PANEL SIZE: 15 1/4" X 97 1/2"
 3. DOOR PANEL D.L.O.: 20" X 78 1/2"
 4. SIDELITE PANEL D.L.O.: 6 7/8" X 78 1/2"
 5. TRANSOM D.L.O.: 102" X 12 3/4"

HARDWARE SCHEDULE	
A.	F-SERIES LOCK ASSEMBLY DOOR KNOB BY SCHLAGE.
B.	B-SERIES DEADBOLT ASSEMBLY BY SCHLAGE.
C.	F-SERIES DEADBOLT ASSEMBLY BY SCHLAGE.
D.	RESIDENTIAL GRADE DOOR HANDLE ASSEMBLY BY EMTEK (ALTERNATE).
E.	MULTI-POINT LOCK HANDLE ASSEMBLY BY TRILENNIUM (ALTERNATE).
F.	INSWING HURRICANE ASTRAGAL BY ENDURA.
G.	OUTSWING HURRICANE ASTRAGAL BY ENDURA.
H.	(3) 4" x 4" BALL BEARING HINGES BY PENROD.
I.	(3) 4" x 4" SPRING BOMMER HINGES BY PENROD.

PROVIA, LLC.
2150 STATE ROUTE 39 WEST
SUGARCREEK, OH 44681

20GA. STEEL IS OR OS DOOR W/ AND W/OUT
14" SIDELITES AND TRANSOM
INSWING ELEVATION

DRAWN: TJH	DWG NO. 08-00708	REV L
SCALE NTS	DATE 03/17/09	SHEET 2 OF 21

L. ROBERTO LOMAS P.E.
1432 WOODFORD RD LEWISVILLE, NC 27023
434-688-0609 rllomas@lrlomaspe.com

SIGNED: 09/09/2021

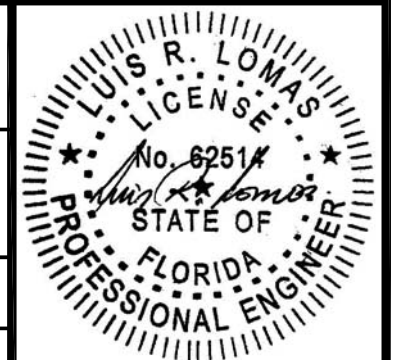

Luis R. Lomas P.E.
FL No.: 62514

REVISIONS			
REV	DESCRIPTION	DATE	APPROVED
L	ADDED COMPOSITE FRAME	09/08/2021	R.L.

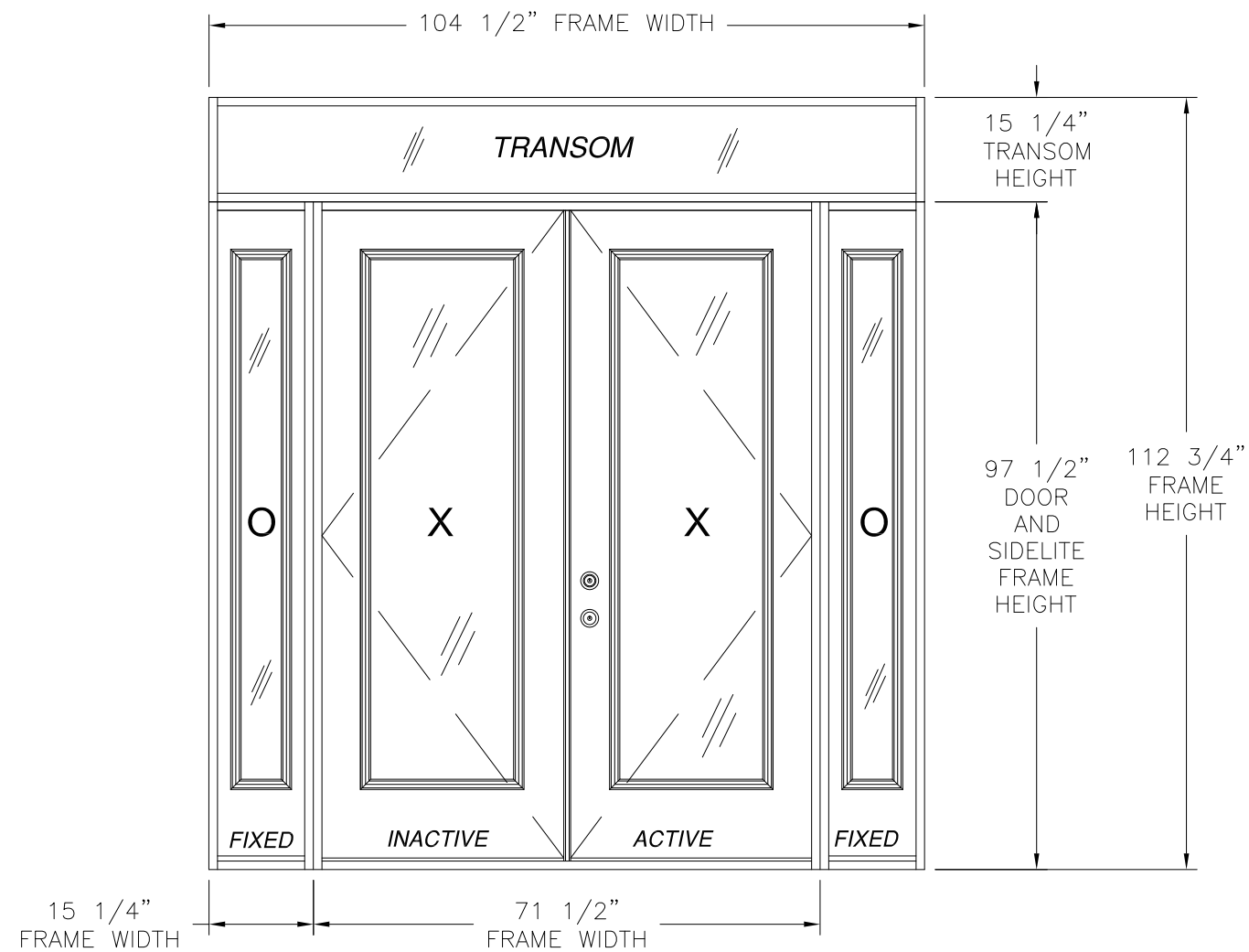

<u>HARDWARE SCHEDULE</u>	
A.	F-SERIES LOCK ASSEMBLY DOOR KNOB BY SCHLAGE.
B.	B-SERIES DEADBOLT ASSEMBLY BY SCHLAGE.
C.	F-SERIES DEADBOLT ASSEMBLY BY SCHLAGE.
D.	RESIDENTIAL GRADE DOOR HANDLE ASSEMBLY BY EMTEK (ALTERNATE).
E.	MULTI-POINT LOCK HANDLE ASSEMBLY BY TRILENNIUM (ALTERNATE).
F.	INSWING HURRICANE ASTRAGAL BY ENDURA.
G.	OUTSWING HURRICANE ASTRAGAL BY ENDURA.
H.	(3) 4" x 4" BALL BEARING HINGES BY PENROD.
I.	(3) 4" x 4" SPRING BOMMER HINGES BY PENROD.

20GA STEEL OS DOUBLE DOOR W/ SIDELITES AND TRANSOM
EXTERIOR VIEW

DESIGN PRESSURE RATING	IMPACT RATING
+45.0PSF / -55.0PSF	NONE
THIS SYSTEM WAS NOT TESTED FOR WATER INFILTRATION AND IS TO BE INSTALLED ONLY WHERE THE WATER REQUIREMENT IS NOT NEEDED	

FOR ADDITIONAL APPROVED CONFIGURATIONS SEE SHEET 4.
35 3/4" x 94 15/16" PANEL SIZE SHOWN. OTHER SIZES ARE APPROVED
AS LONG AS INDIVIDUAL PANEL AREA DOES NOT EXCEED 23.56 FT²

NOTES:

- DOOR PANEL SIZE: 35 3/4" X 94 15/16"
- SIDELITE PANEL SIZE: 15 1/4" X 97 1/2"
- DOOR PANEL D.L.O.: 20" X 78 1/2"
- SIDELITE PANEL D.L.O.: 6 7/8" X 78 1/2"
- TRANSOM D.L.O.: 102" X 12 3/4"

SIGNED: 09/09/2021

PROVIA, LLC. 2150 STATE ROUTE 39 WEST SUGARCREEK, OH 44681		
20GA. STEEL IS OR OS DOOR W/ AND W/OUT 14" SIDELITES AND TRANSOM OUTSWING ELEVATION AND HARDWARE		
DRAWN: TJH	DWG NO. 08-00708	REV L
SCALE NTS	DATE 03/17/09	SHEET 3 OF 21
L. ROBERTO LOMAS P.E. 1432 WOODFORD RD LEWISVILLE, NC 27023 434-688-0609 rllomas@lrlomaspe.com		

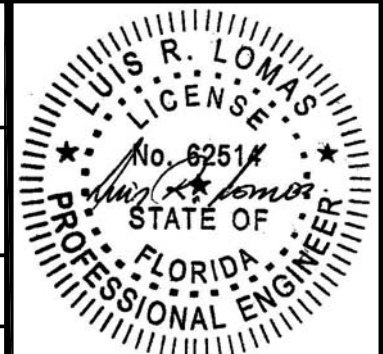

Luis R. Lomas P.E.
FL No.: 62514

REVISIONS			
REV	DESCRIPTION	DATE	APPROVED
L	ADDED COMPOSITE FRAME	09/08/2021	R.L.

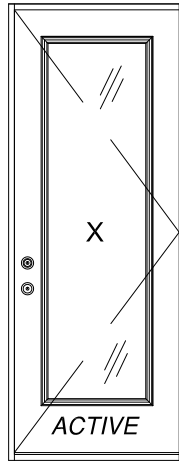

SINGLE

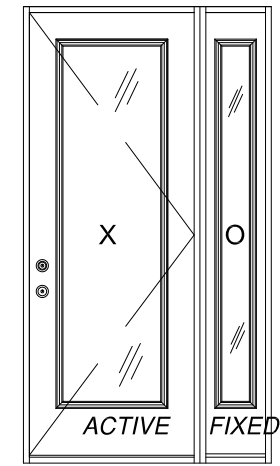

SINGLE W/SIDELITE

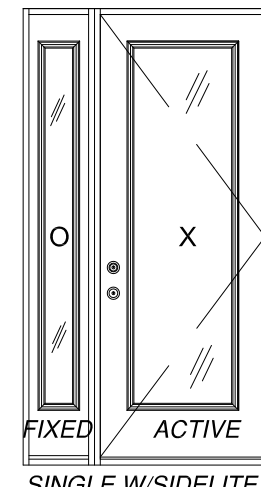

SINGLE W/SIDELITE

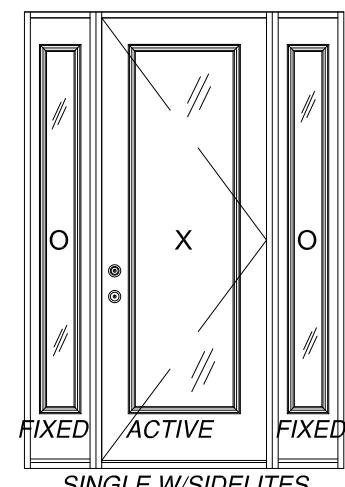

SINGLE W/SIDELITES

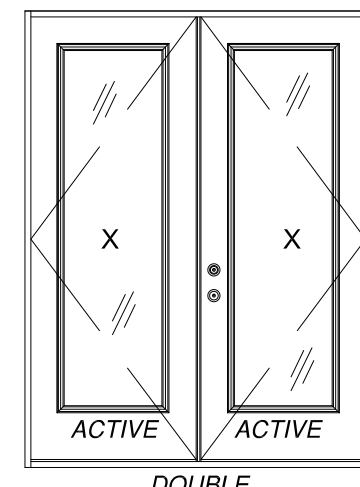

DOUBLE

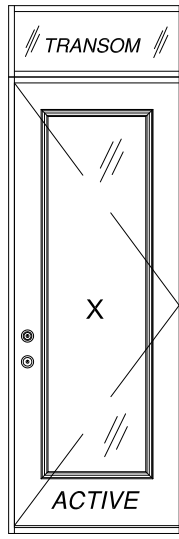

SINGLE W/TRANSOM

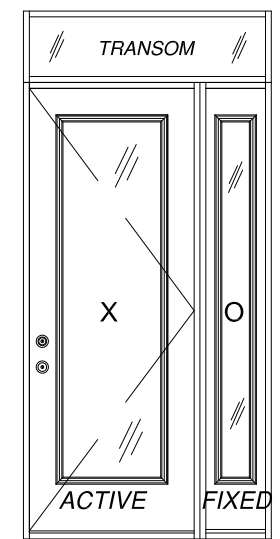

SINGLE W/SIDELITE & TRANSOM

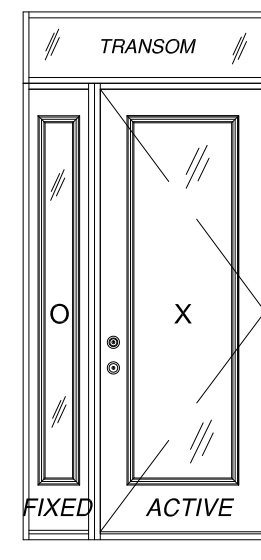

SINGLE W/SIDELITE & TRANSOM

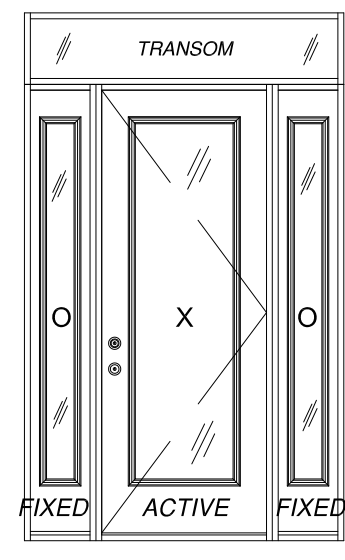

SINGLE W/SIDELITES & TRANSOM

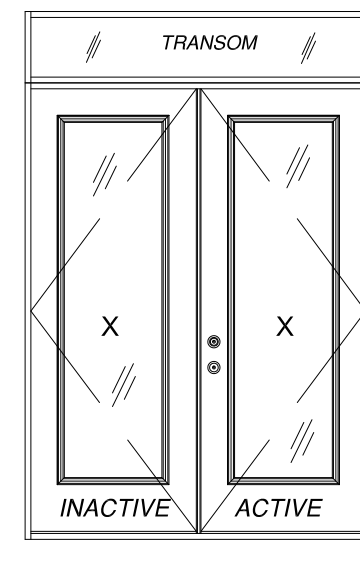

DOUBLE W/TRANSOM

NOTE:
ALL APPROVED CONFIGURATIONS CAN BE
INSWING OR OUTSWING MODELS. ALL
APPROVED CONFIGURATIONS ARE SHOWN AS
RIGHT HAND ACTIVE, LEFT HAND ACTIVE IS
ALSO APPROVED.

APPROVED LITE CONFIGURATIONS

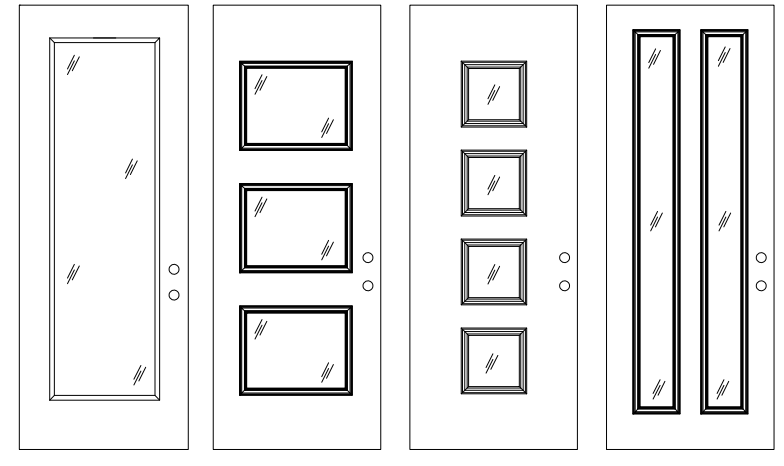

FULL LITE 3 LITE 4 LITE 2 LITE

LITE CONFIGURATIONS SHOWN ARE FOR REFERENCE ONLY. MULTIPLE LITE CONFIGURATIONS ARE APPROVED AS LONG AS LITE SIZE DOES NOT EXCEED 11.5 FT²

SIGNED: 09/09/2021

PROVIA, LLC.
2150 STATE ROUTE 39 WEST
SUGARCREEK, OH 44681

20GA. STEEL IS OR OS DOOR W/ AND W/OUT
14" SIDELITES AND TRANSOM
INSWING/OUTSWING ADDITIONAL CONFIGURATIONS

DRAWN: TJH	DWG NO. 08-00708	REV L
SCALE NTS	DATE 03/17/09	SHEET 4 OF 21

L. ROBERTO LOMAS P.E.
1432 WOODFORD RD LEWISVILLE, NC 27023
434-688-0609 rllomas@lrlomaspe.com

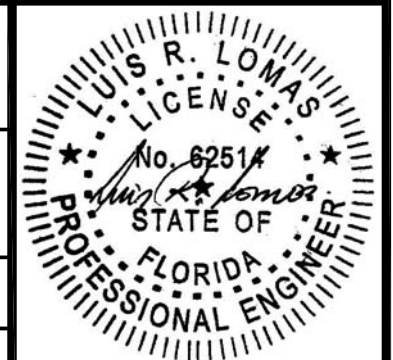

Luis R. Lomas P.E.
FL No.: 62514

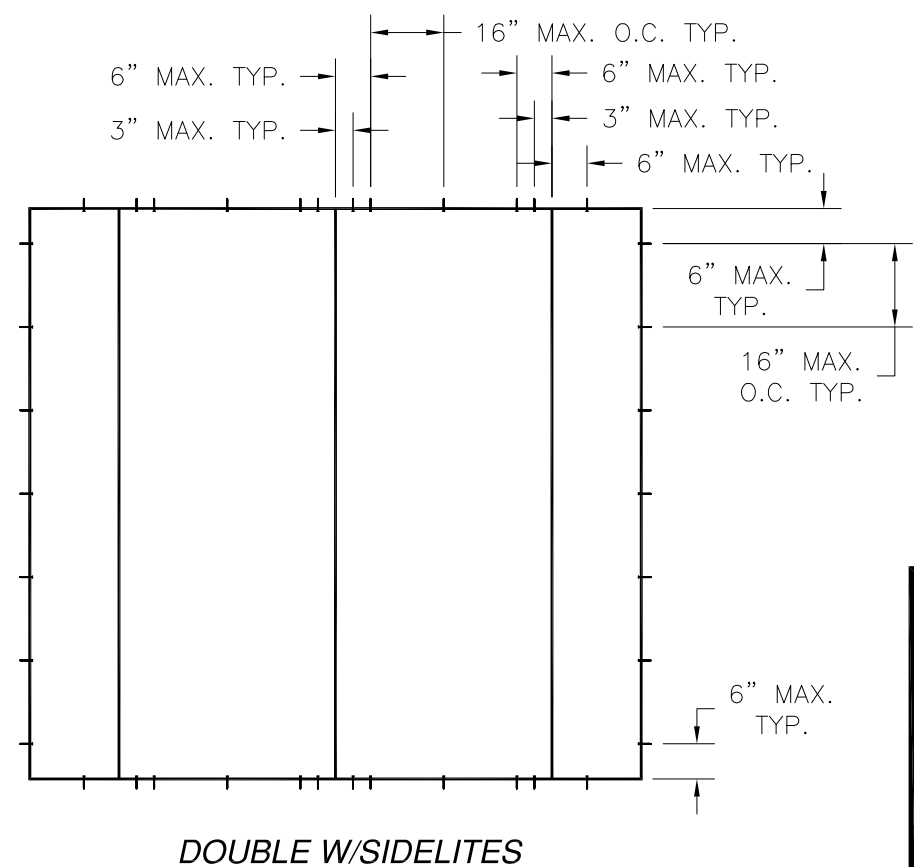
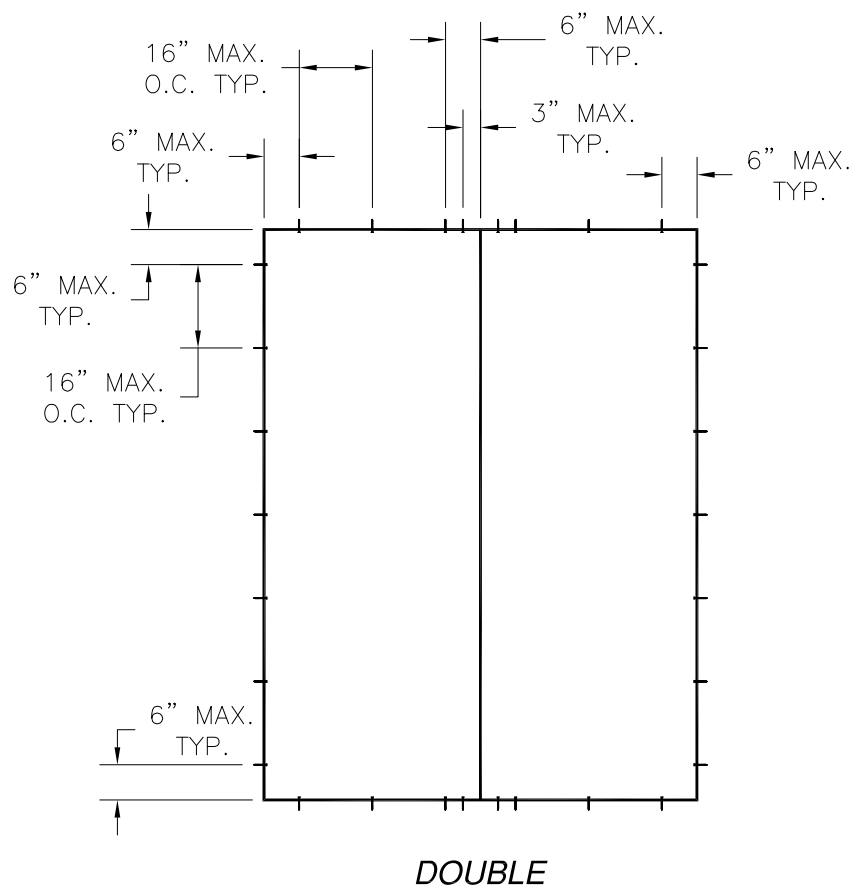
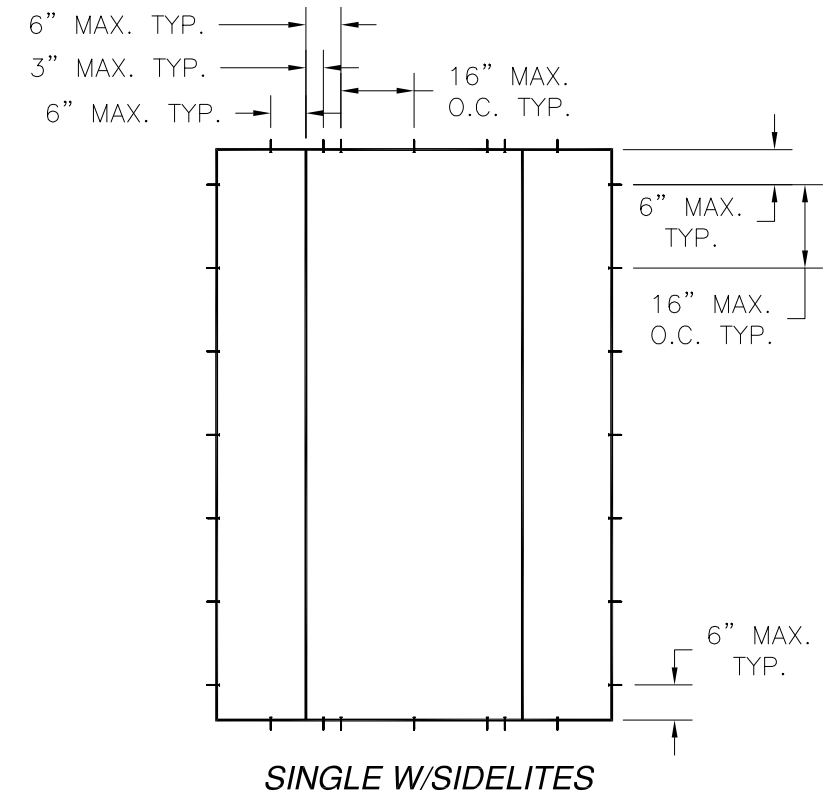
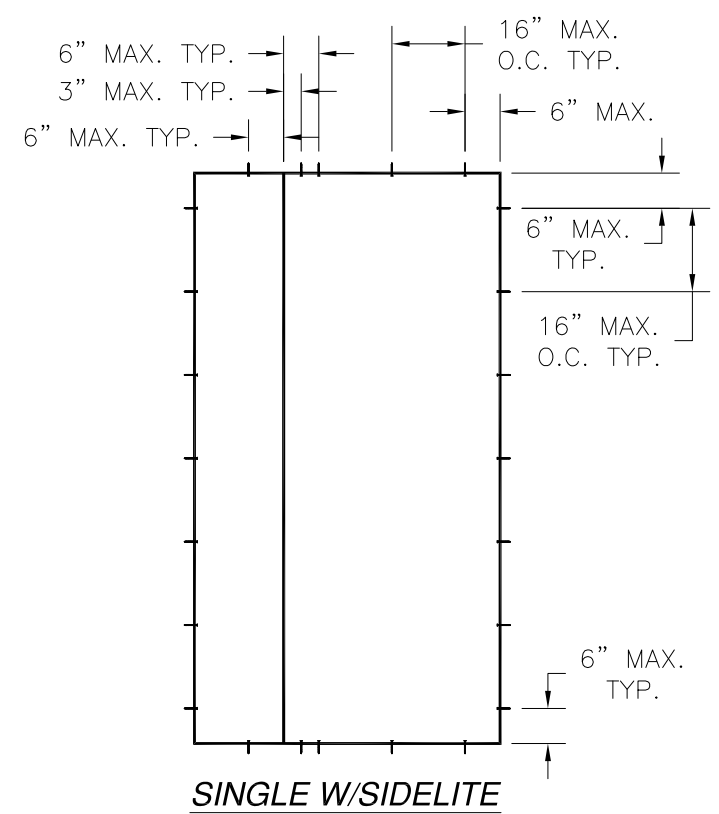
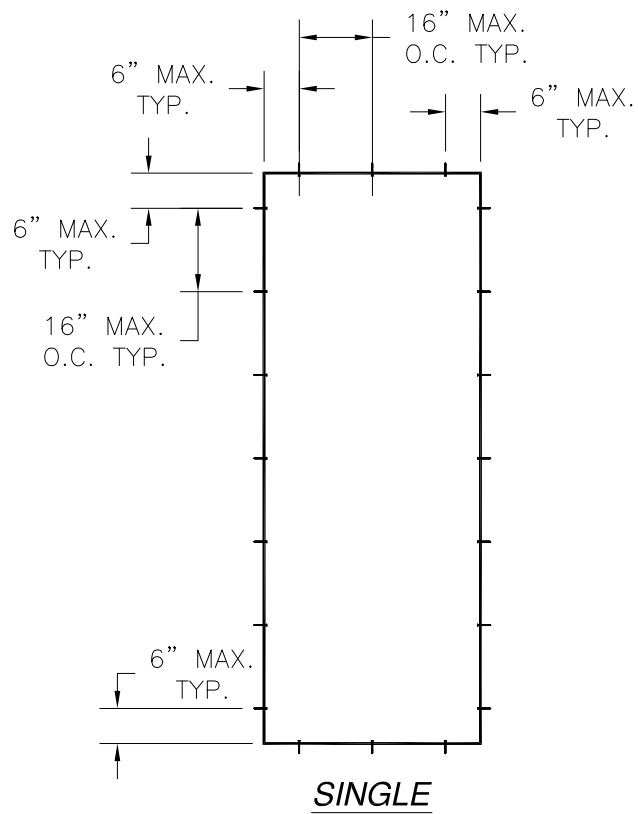

REVISIONS			
REV	DESCRIPTION	DATE	APPROVED
L	ADDED COMPOSITE FRAME	09/08/2021	R.L.

PROVIA, LLC.
2150 STATE ROUTE 39 WEST
SUGARCREEK, OH 44681

20GA. STEEL IS OR OS DOOR W/ AND W/OUT
14" SIDELITES AND TRANSOM
ANCHORING LAYOUTS WITHOUT TRANSOMS

DRAWN: TJH	DWG NO. 08-00708	REV L
SCALE NTS	DATE 03/17/09	SHEET 5 OF 21

L. ROBERTO LOMAS P.E.
1432 WOODFORD RD LEWISVILLE, NC 27023
434-688-0609 rllomas@lrlomaspe.com

SIGNED: 09/09/2021

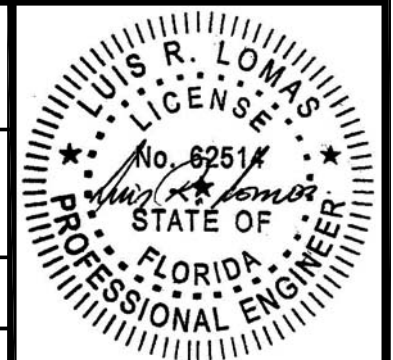

Luis R. Lomas P.E.
FL No.: 62514

REVISIONS			
REV	DESCRIPTION	DATE	APPROVED
L	ADDED COMPOSITE FRAME	09/08/2021	R.L.

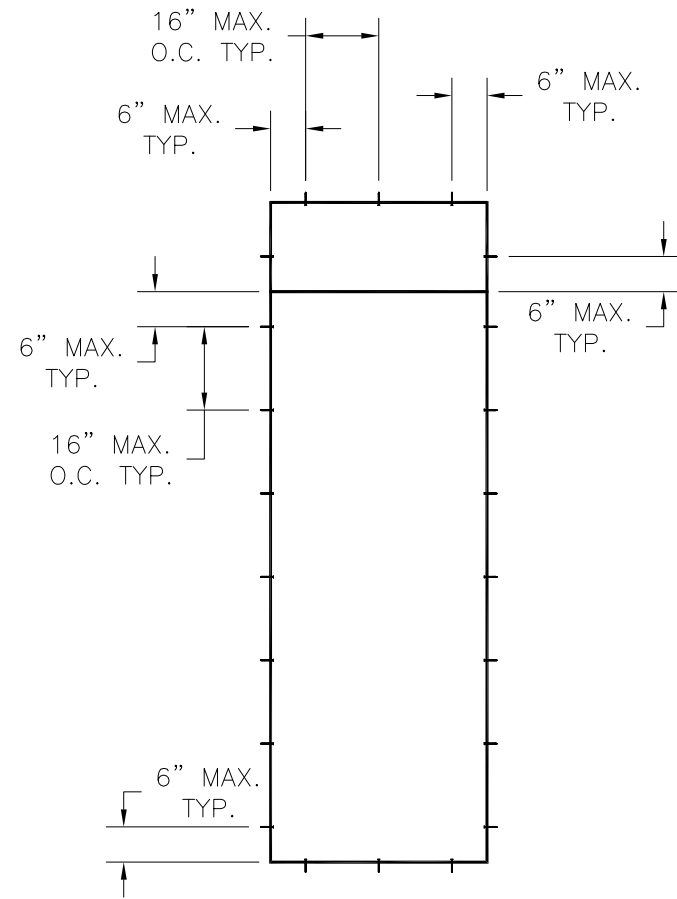

SINGLE W/TRANSOM

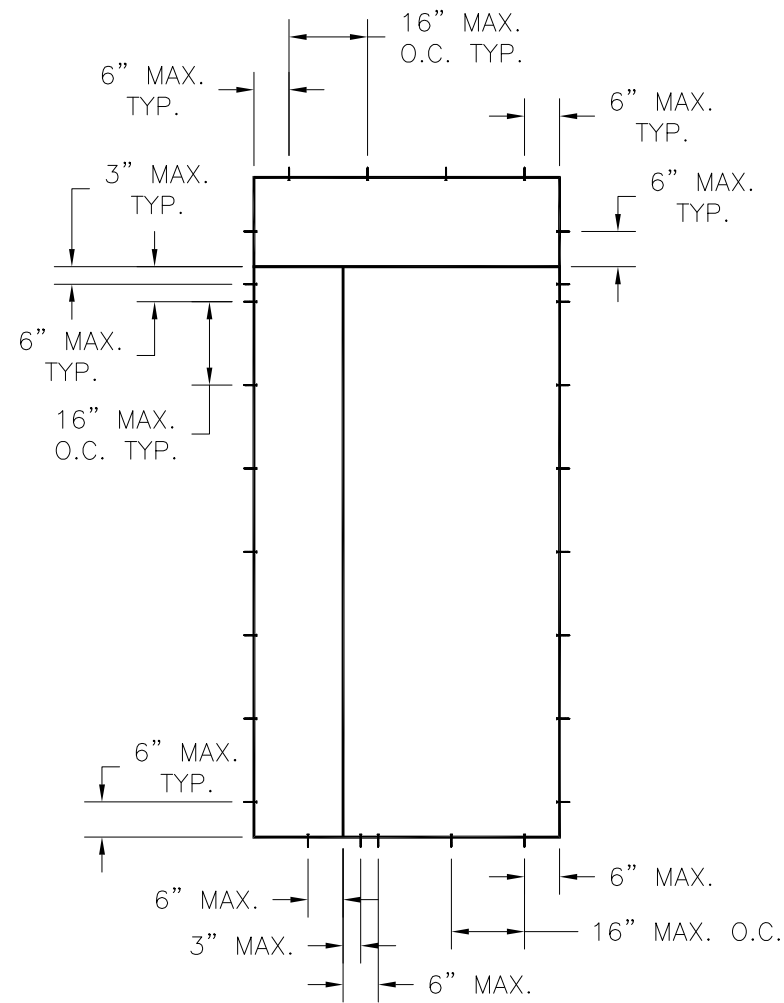

SINGLE W/SIDELITE & TRANSOM

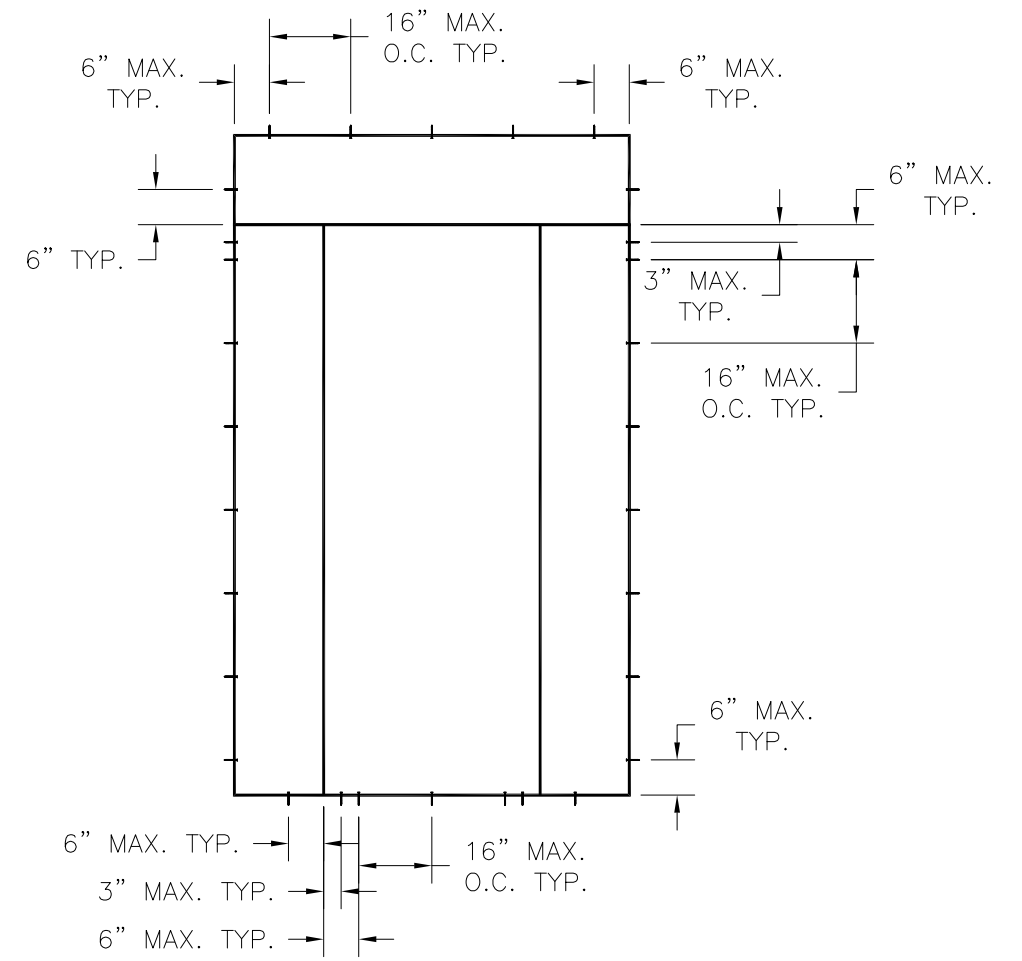

SINGLE W/SIDELITES & TRANSOM

SIGNED: 09/09/2021

PROVIA, LLC.
 2150 STATE ROUTE 39 WEST
 SUGARCREEK, OH 44681

20GA. STEEL IS OR OS DOOR W/ AND W/OUT
 14" SIDELITES AND TRANSOM
 ANCHORING LAYOUTS WITH TRANSOMS

DRAWN: TJH	DWG NO. 08-00708	REV L
SCALE NTS	DATE 03/17/09	SHEET 6 OF 21

L. ROBERTO LOMAS P.E.
 1432 WOODFORD RD LEWISVILLE, NC 27023
 434-688-0609 rllomas@rlomaspe.com

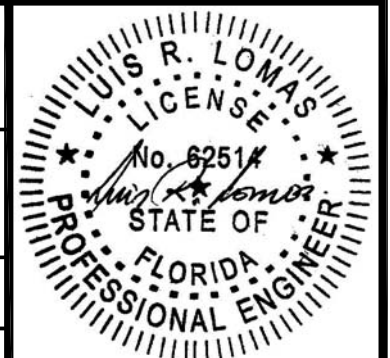

Luis R. Lomas P.E.
 FL No.: 62514

REVISIONS			
REV	DESCRIPTION	DATE	APPROVED
L	ADDED COMPOSITE FRAME	09/08/2021	R.L.

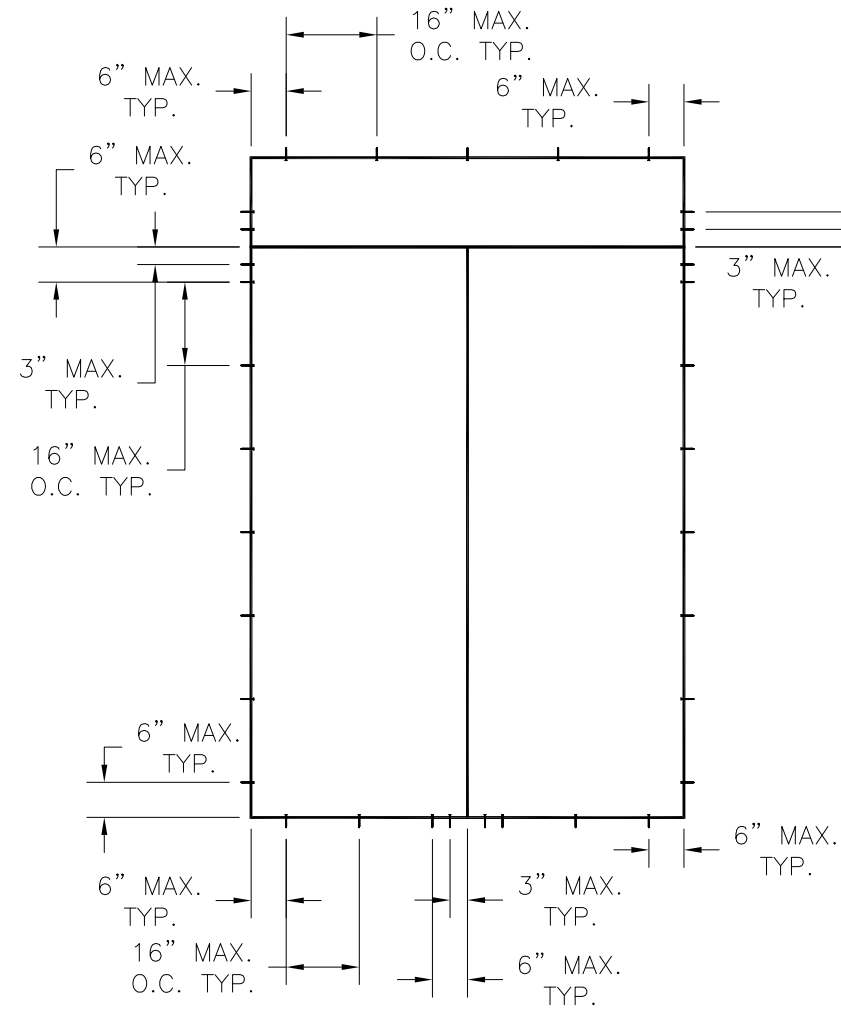

DOUBLE W/TRANSOM

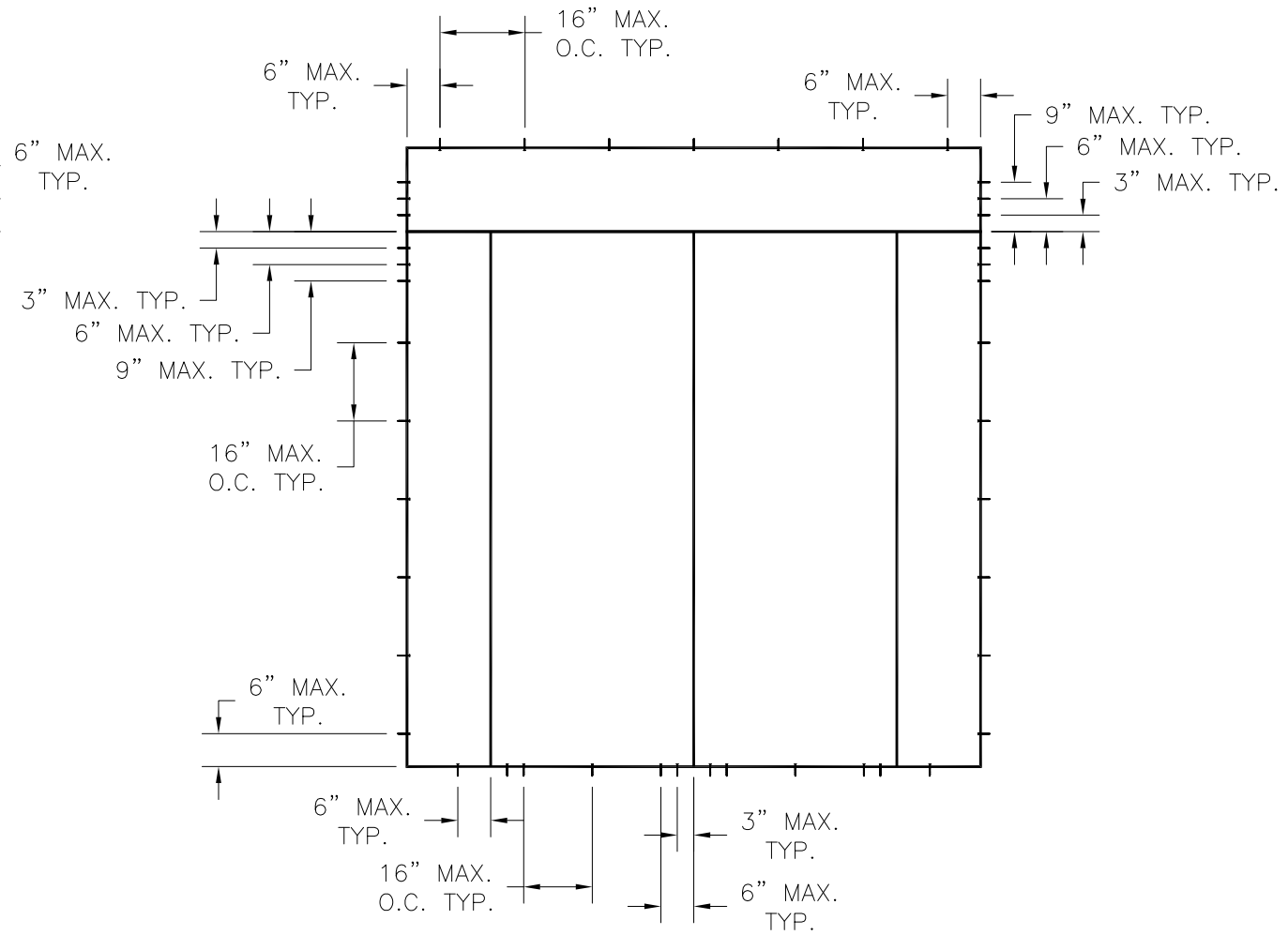

DOUBLE W/SIDELITES & TRANSOM

SIGNED: 09/09/2021

PROVIA, LLC. 2150 STATE ROUTE 39 WEST SUGARCREEK, OH 44681		
20GA. STEEL IS OR OS DOOR W/ AND W/OUT 14" SIDELITES AND TRANSOM ANCHORING LAYOUTS WITH TRANSOMS		
DRAWN: TJH	DWG NO. 08-00708	REV L
SCALE NTS	DATE 03/17/09	SHEET 7 OF 21
L. ROBERTO LOMAS P.E. 1432 WOODFORD RD LEWISVILLE, NC 27023 434-688-0609 rllomas@rlomaspe.com		

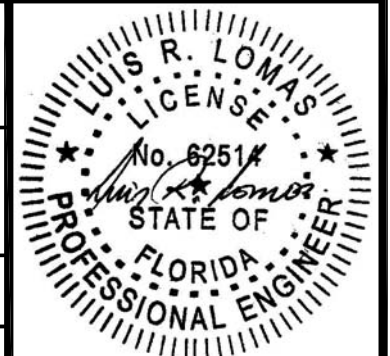

Luis R. Lomas P.E.
FL No.: 62514

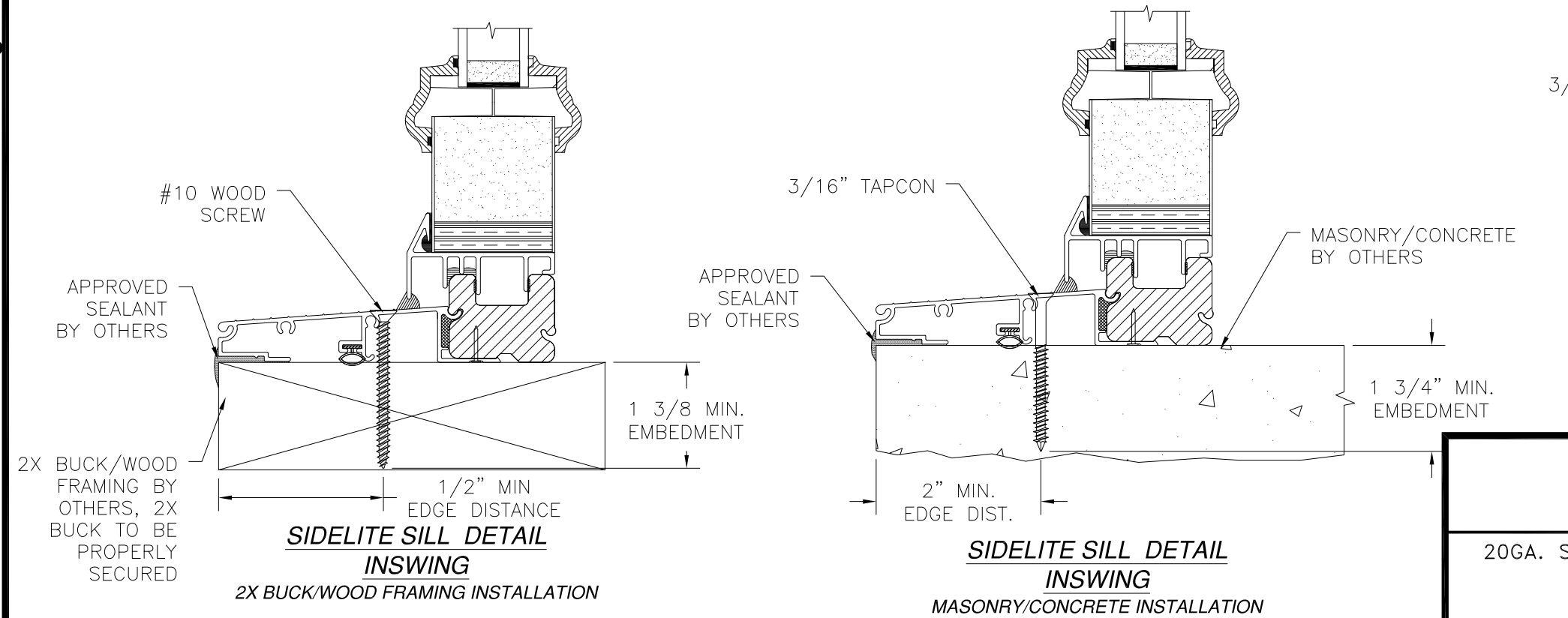
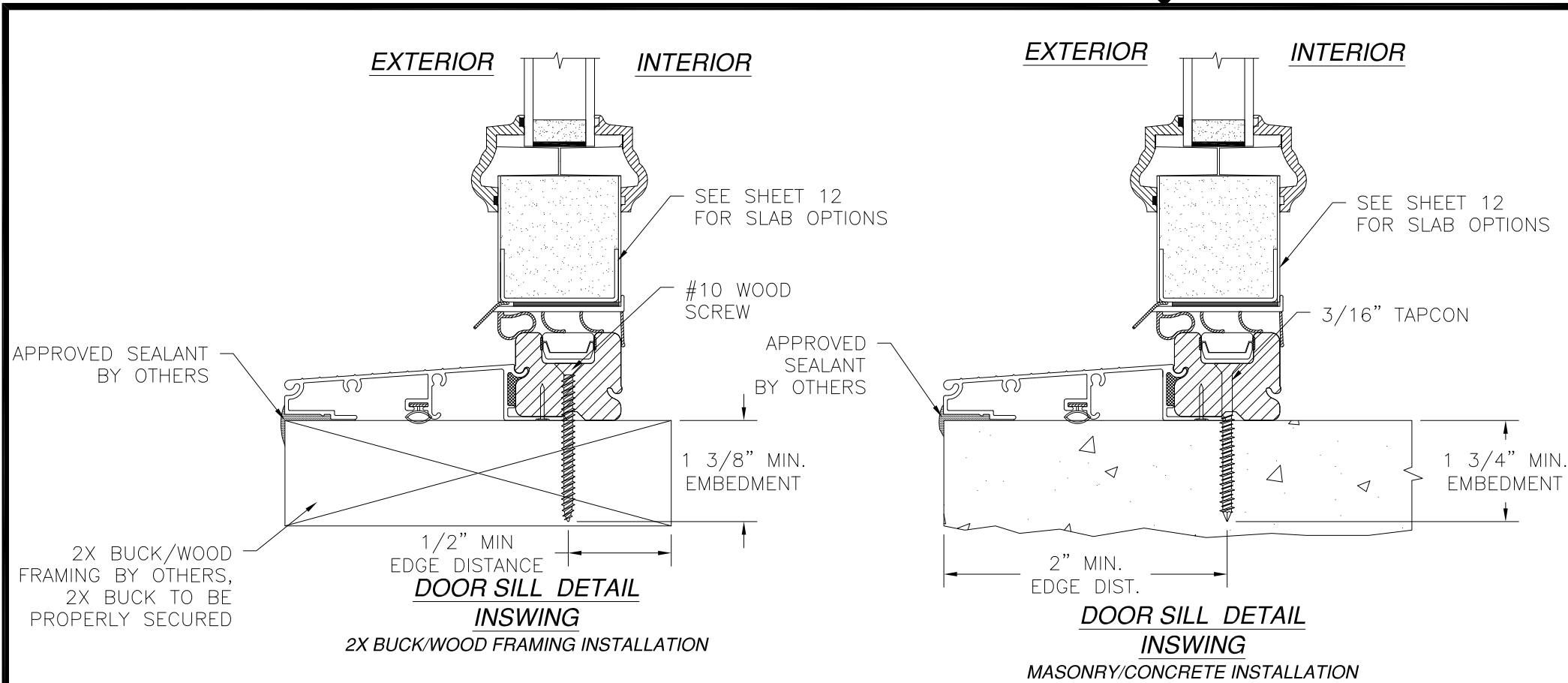

REVISIONS			
REV	DESCRIPTION	DATE	APPROVED
L	ADDED COMPOSITE FRAME	09/08/2021	R.L.

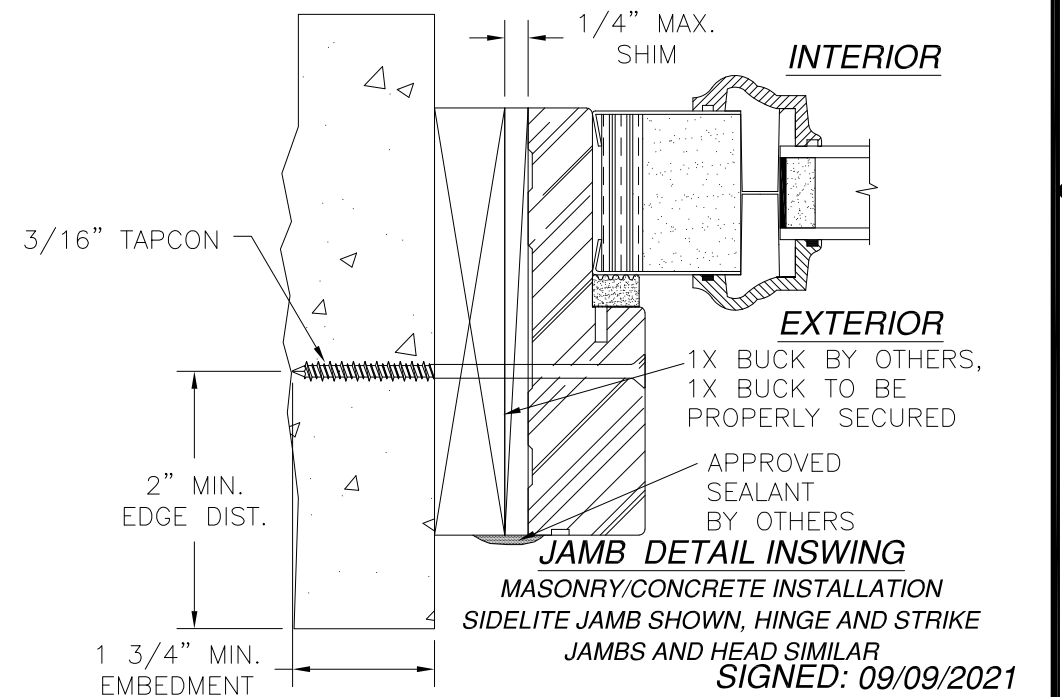
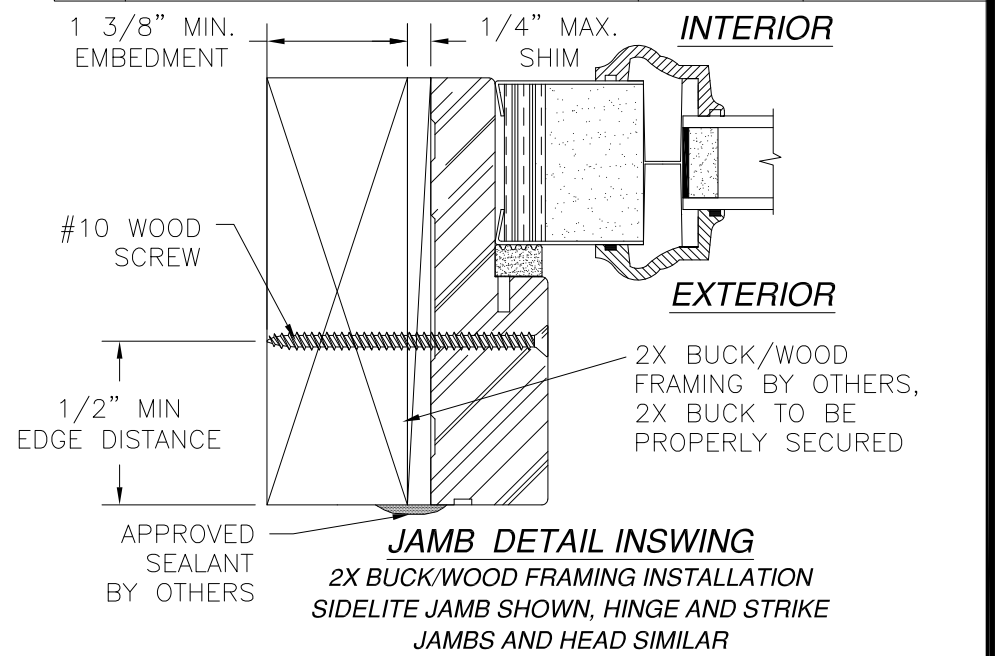

- NOTES:**
- INTERIOR AND EXTERIOR FINISHES, BY OTHERS, NOT SHOWN FOR CLARITY.
 - PERIMETER AND JOINT SEALANT BY OTHERS TO BE DESIGNED IN ACCORDANCE WITH ASTM E2112

PROVIA, LLC.
2150 STATE ROUTE 39 WEST
SUGARCREEK, OH 44681

20GA. STEEL IS OR OS DOOR W/ AND W/OUT
14" SIDELITES AND TRANSOM
INSWING INSTALLATION DETAILS

DRAWN: TJH	DWG NO. 08-00708	REV L
SCALE NTS	DATE 03/17/09	SHEET 8 OF 21

L. ROBERTO LOMAS P.E.
1432 WOODFORD RD LEWISVILLE, NC 27023
434-688-0609 rllomas@rlomaspe.com

Luis R. Lomas P.E.
FL No.: 62514

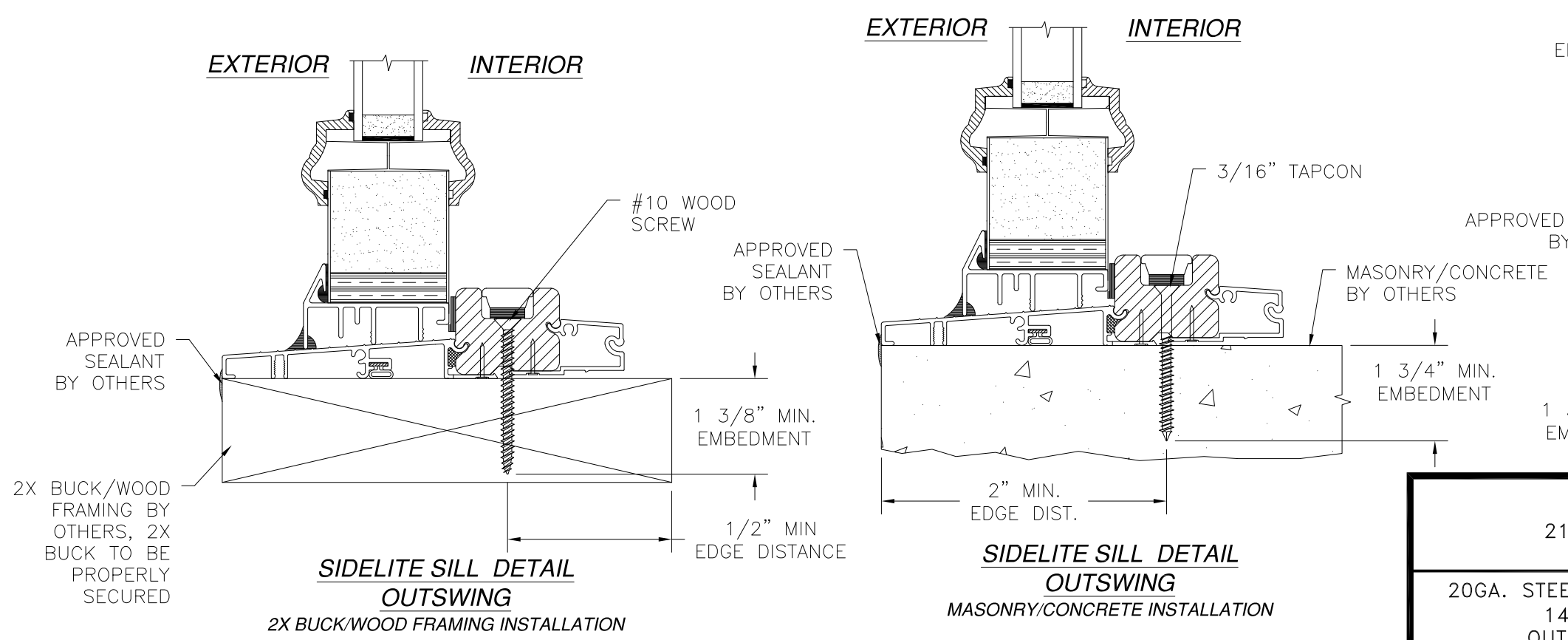
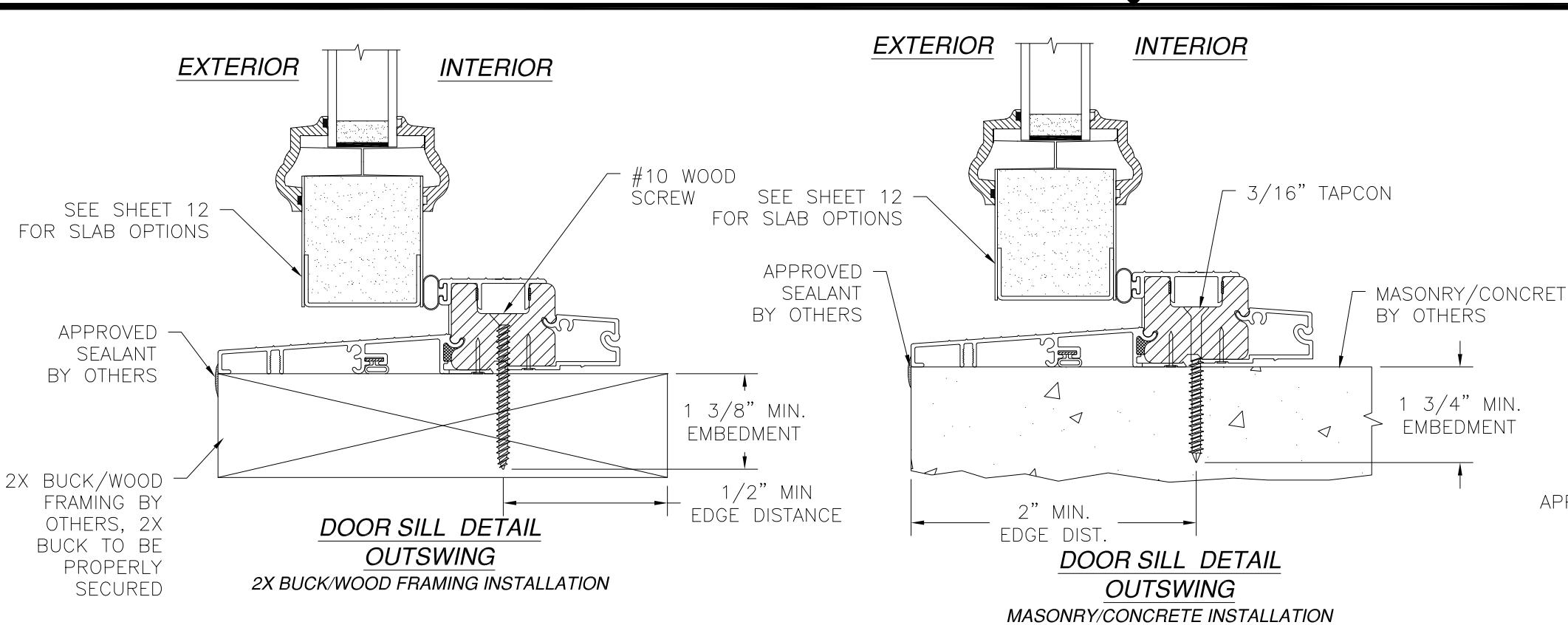

REVISIONS			
REV	DESCRIPTION	DATE	APPROVED
L	ADDED COMPOSITE FRAME	09/08/2021	R.L.

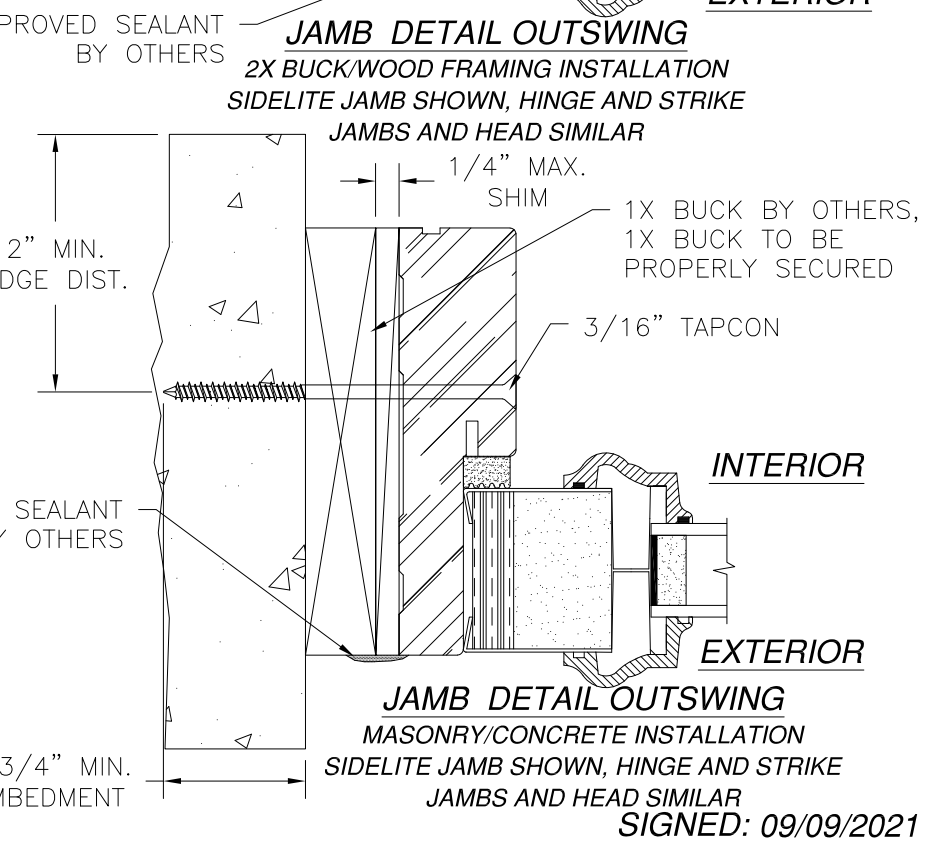
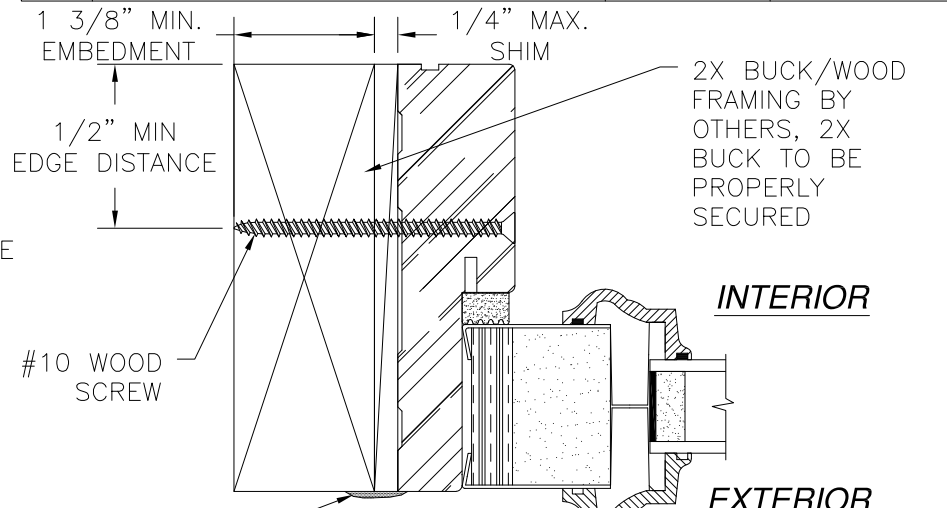

NOTES:
 1. INTERIOR AND EXTERIOR FINISHES, BY OTHERS, NOT SHOWN FOR CLARITY.
 2. PERIMETER AND JOINT SEALANT BY OTHERS TO BE DESIGNED IN ACCORDANCE WITH ASTM E2112

PROVIA, LLC.
 2150 STATE ROUTE 39 WEST
 SUGARCREEK, OH 44681

20GA. STEEL IS OR OS DOOR W/ AND W/OUT
 14" SIDELITES AND TRANSOM
 OUTSWING INSTALLATION DETAILS

DRAWN: TJH	DWG NO. 08-00708	REV L
SCALE NTS	DATE 03/17/09	SHEET 9 OF 21

L. ROBERTO LOMAS P.E.
 1432 WOODFORD RD LEWISVILLE, NC 27023
 434-688-0609 rllomas@rlomaspe.com

Luis R. Lomas P.E.
 FL No.: 62514

REVISIONS			
REV	DESCRIPTION	DATE	APPROVED
L	ADDED COMPOSITE FRAME	09/08/2021	R.L.

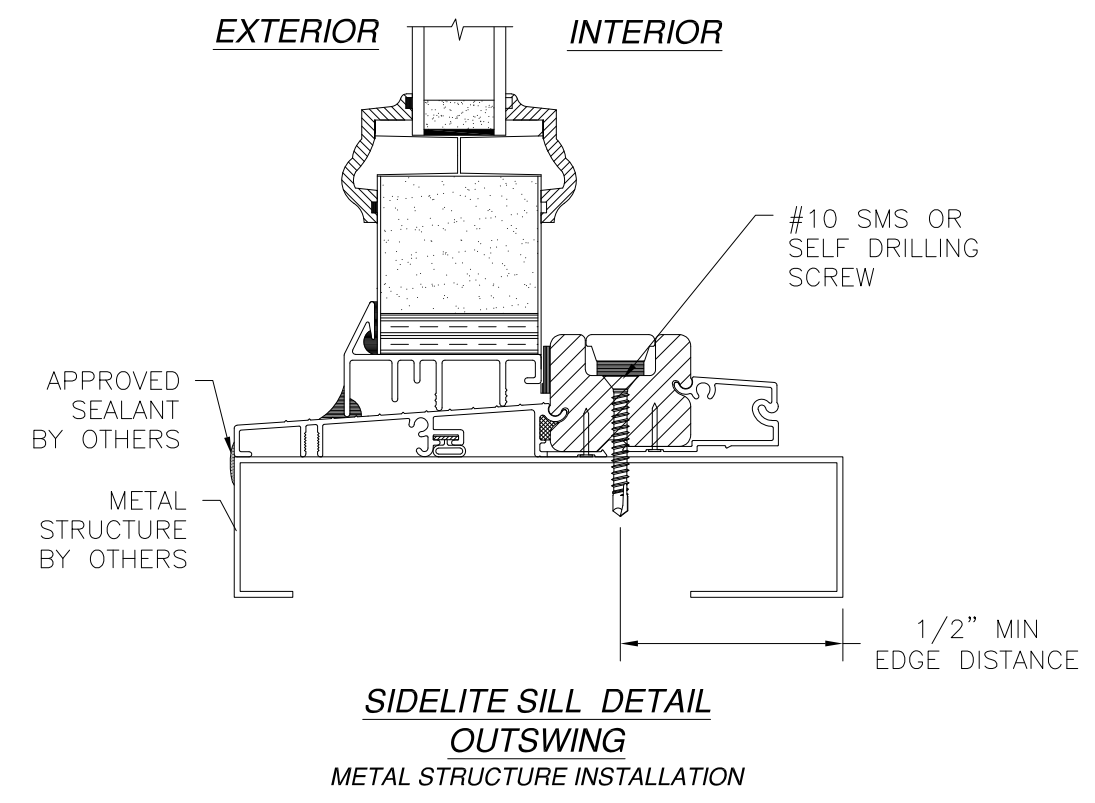
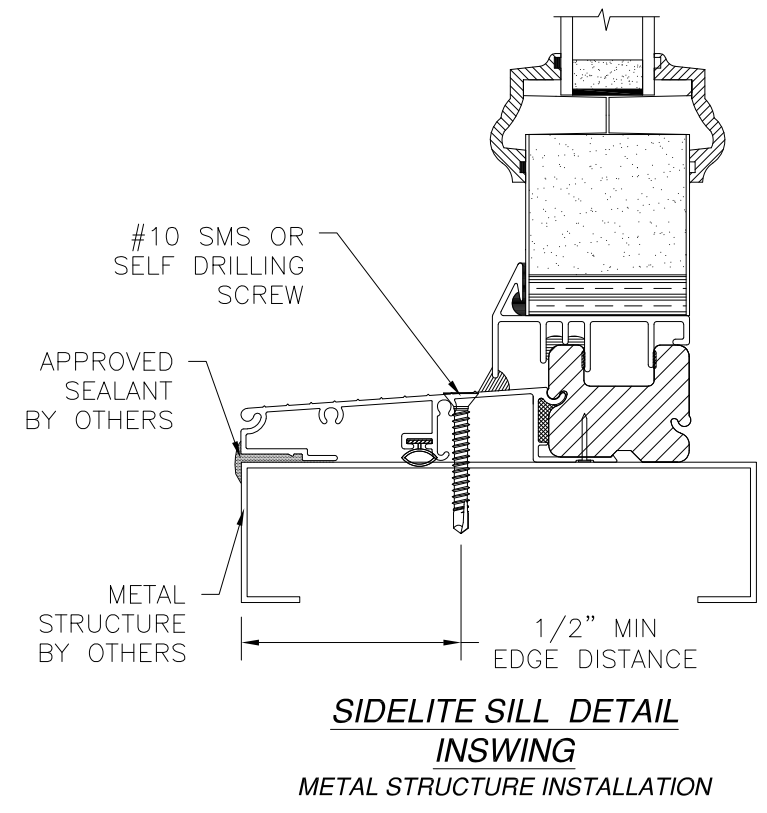
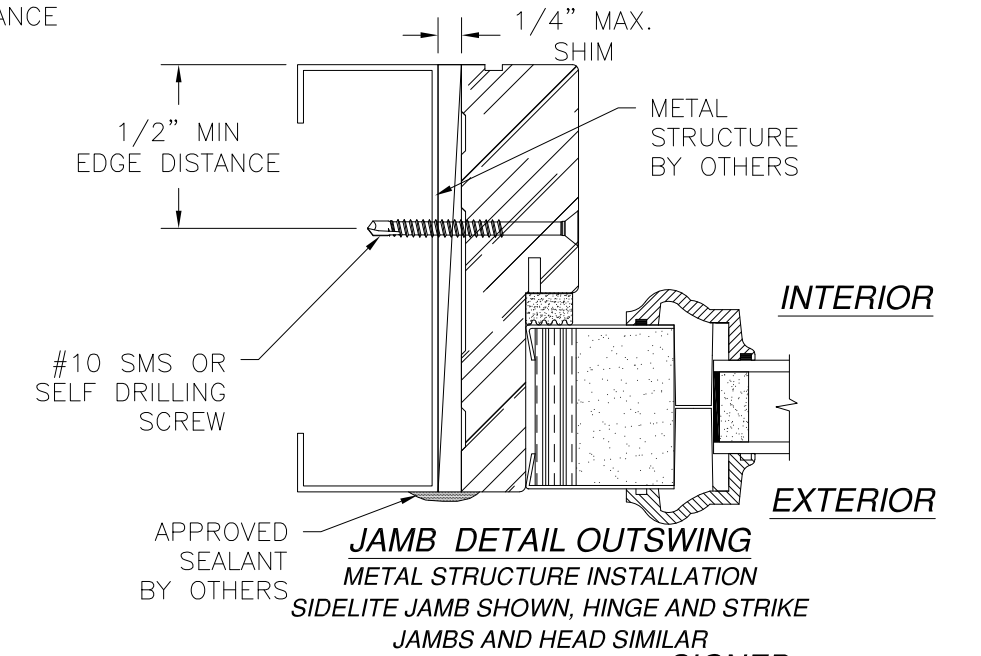
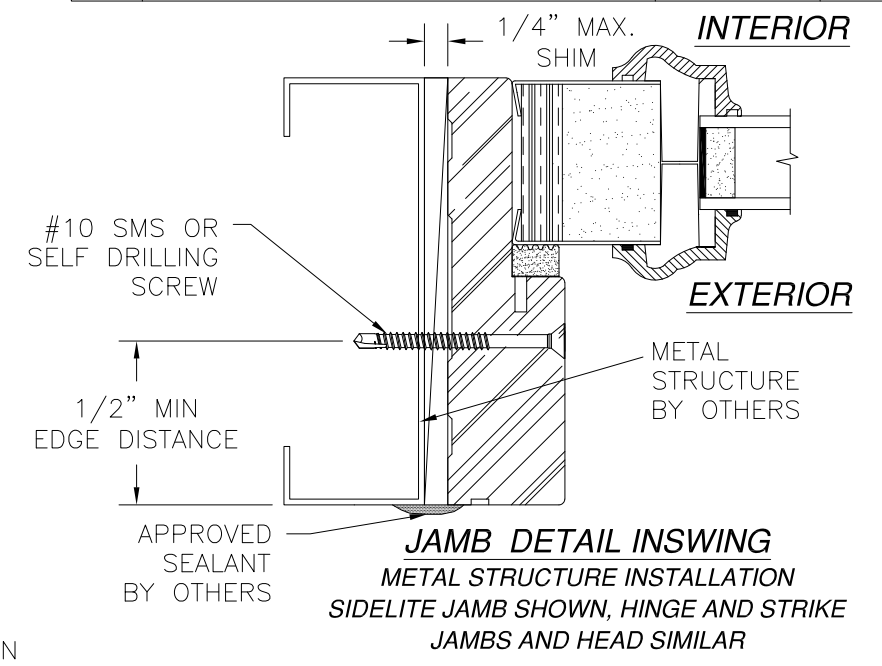
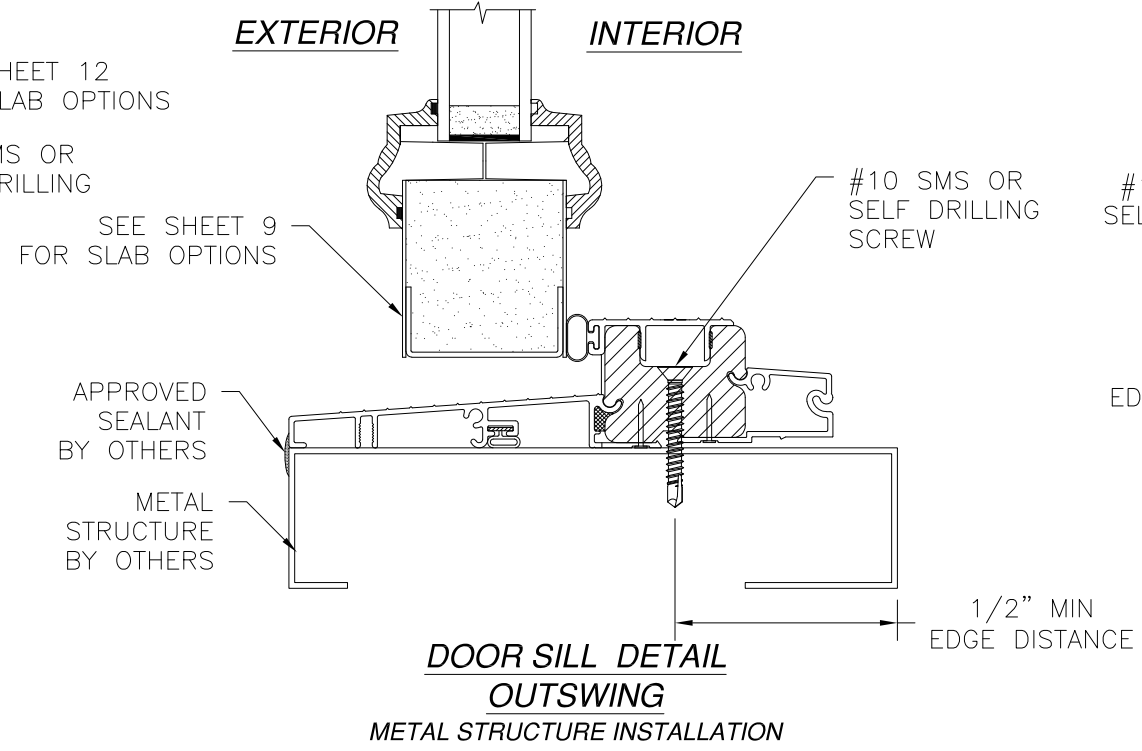
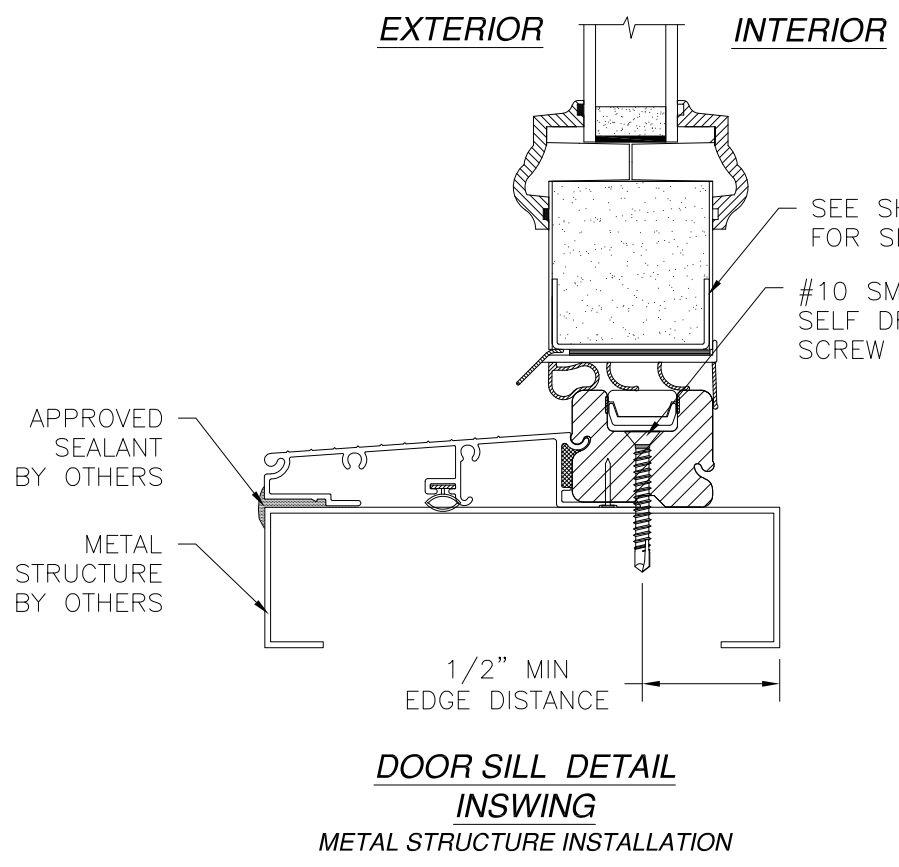

- NOTES:**
- INTERIOR AND EXTERIOR FINISHES, BY OTHERS, NOT SHOWN FOR CLARITY.
 - PERIMETER AND JOINT SEALANT BY OTHERS TO BE DESIGNED IN ACCORDANCE WITH ASTM E2112

PROVIA, LLC.
2150 STATE ROUTE 39 WEST
SUGARCREEK, OH 44681

20GA. STEEL IS OR OS DOOR W/ AND W/OUT
14" SIDELITES AND TRANSOM
METAL INSTALLATION DETAILS

DRAWN: TJH	DWG NO. 08-00708	REV L
SCALE NTS	DATE 03/17/09	SHEET 10 OF 21

L. ROBERTO LOMAS P.E.
1432 WOODFORD RD LEWISVILLE, NC 27023
434-688-0609 rllomas@rlomaspe.com

SIGNED: 09/09/2021

Luis R. Lomas P.E.
FL No.: 62514

REVISIONS			
REV	DESCRIPTION	DATE	APPROVED
L	ADDED COMPOSITE FRAME	09/08/2021	R.L.

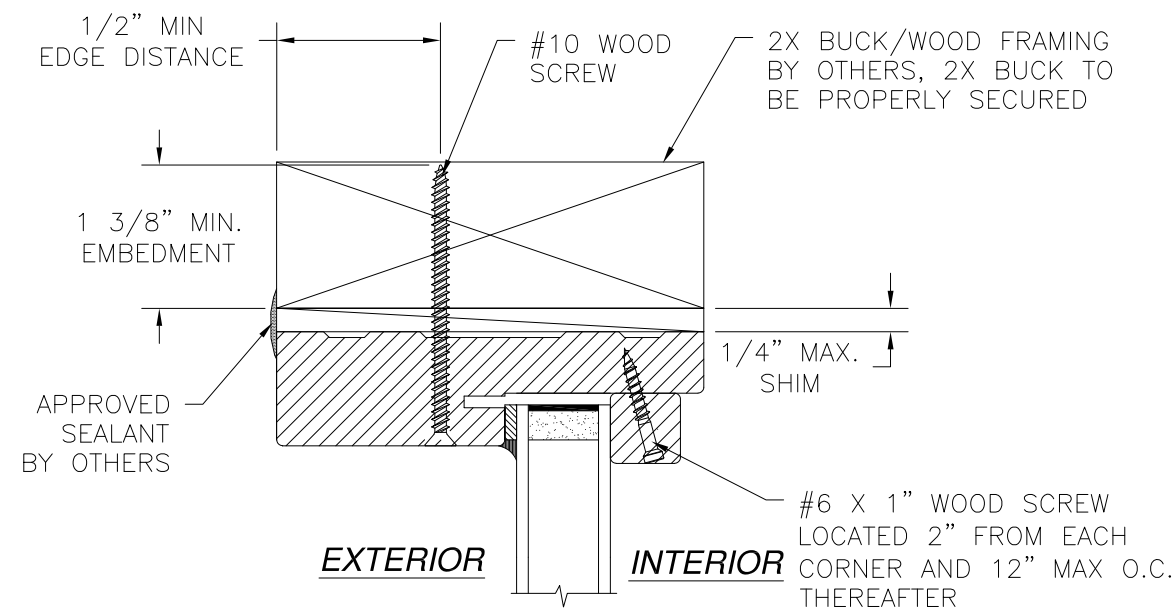

**TRANSOM DETAIL
INSWING/OUTSWING
2X BUCK/WOOD FRAMING INSTALLATION
HEAD SHOWN JAMBS SIMILAR**

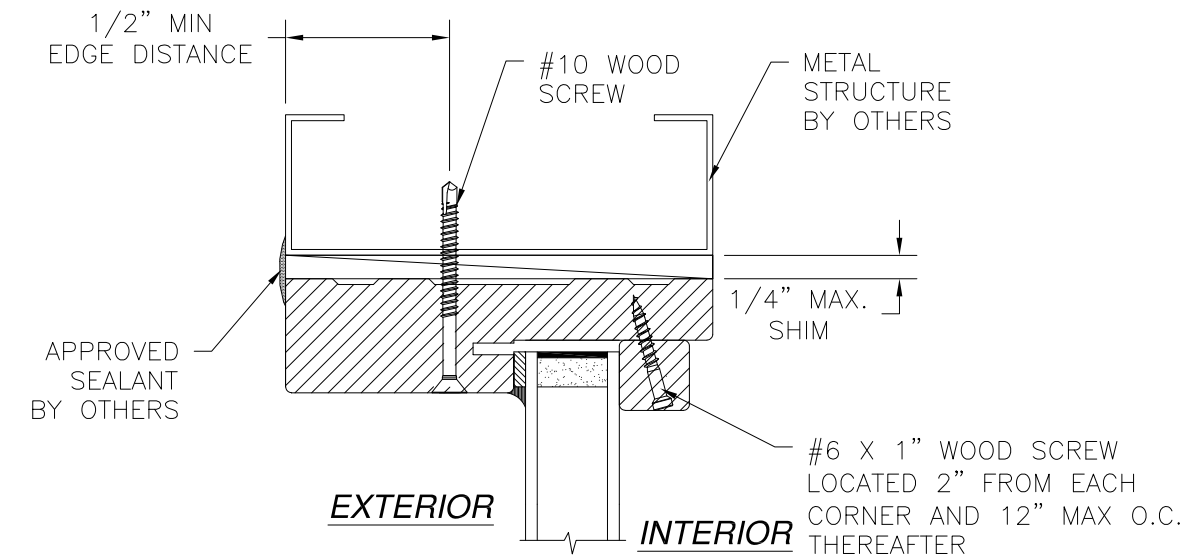

**TRANSOM DETAIL
INSWING/OUTSWING
METAL STRUCTURE INSTALLATION
HEAD SHOWN JAMBS SIMILAR**

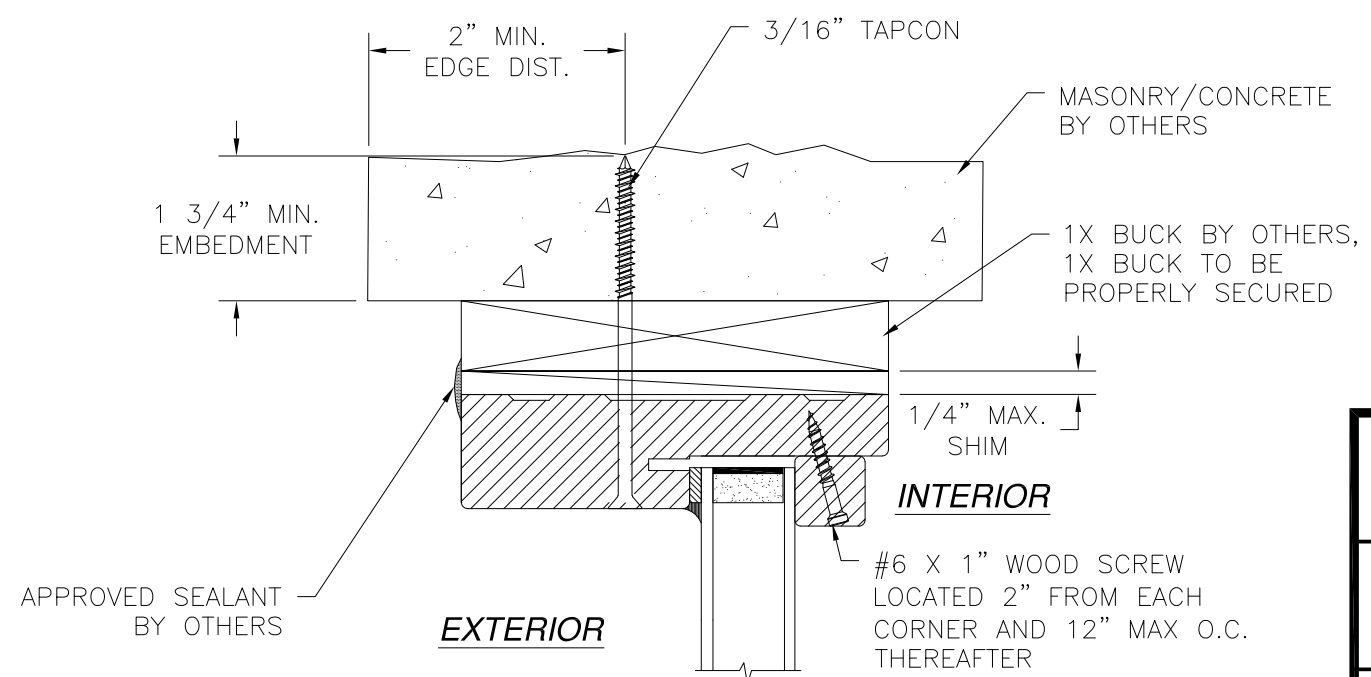

**TRANSOM DETAIL
INSWING/OUTSWING
MASONRY/CONCRETE INSTALLATION
HEAD SHOWN JAMBS SIMILAR**

- NOTES:**
- INTERIOR AND EXTERIOR FINISHES, BY OTHERS, NOT SHOWN FOR CLARITY.
 - PERIMETER AND JOINT SEALANT BY OTHERS TO BE DESIGNED IN ACCORDANCE WITH ASTM E2112

SIGNED: 09/09/2021

PROVIA, LLC.
2150 STATE ROUTE 39 WEST
SUGARCREEK, OH 44681

20GA. STEEL IS OR OS DOOR W/ AND W/OUT
14" SIDELITES AND TRANSOM
INSTALLATION DETAILS

DRAWN: TJH	DWG NO. 08-00708	REV L
SCALE NTS	DATE 03/17/09	SHEET 11 OF 21

L. ROBERTO LOMAS P.E.
1432 WOODFORD RD LEWISVILLE, NC 27023
434-688-0609 rllomas@rlomaspe.com



Luis R. Lomas P.E.
FL No.: 62514

REVISIONS			
REV	DESCRIPTION	DATE	APPROVED
L	ADDED COMPOSITE FRAME	09/08/2021	R.L.

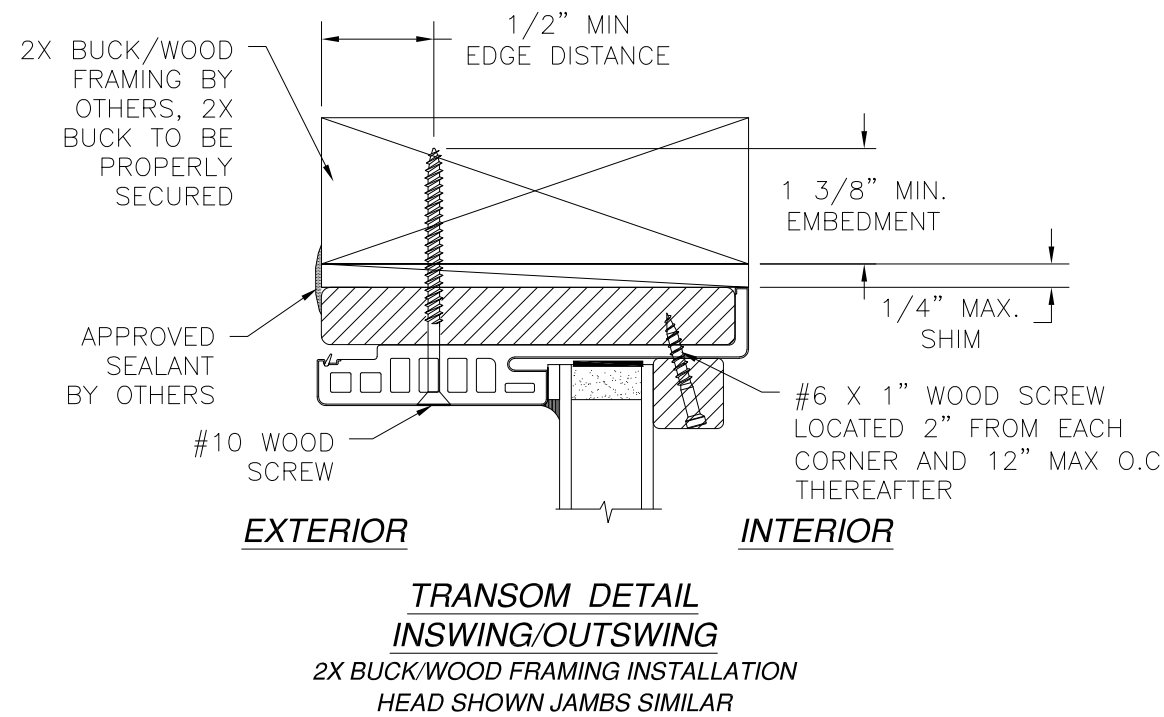
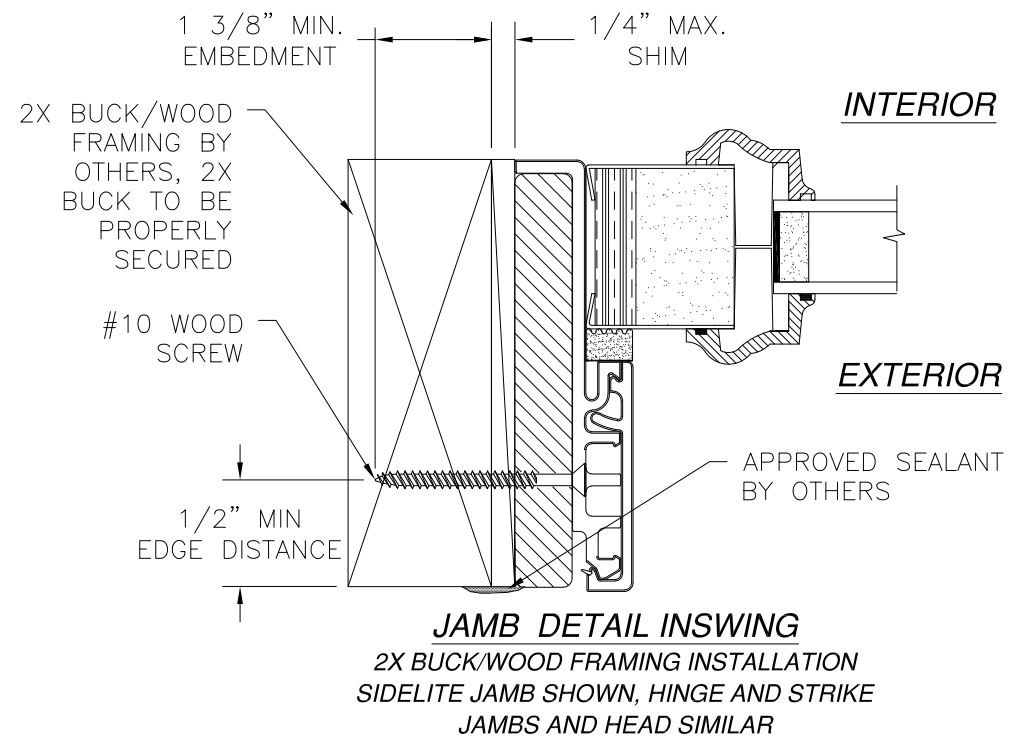
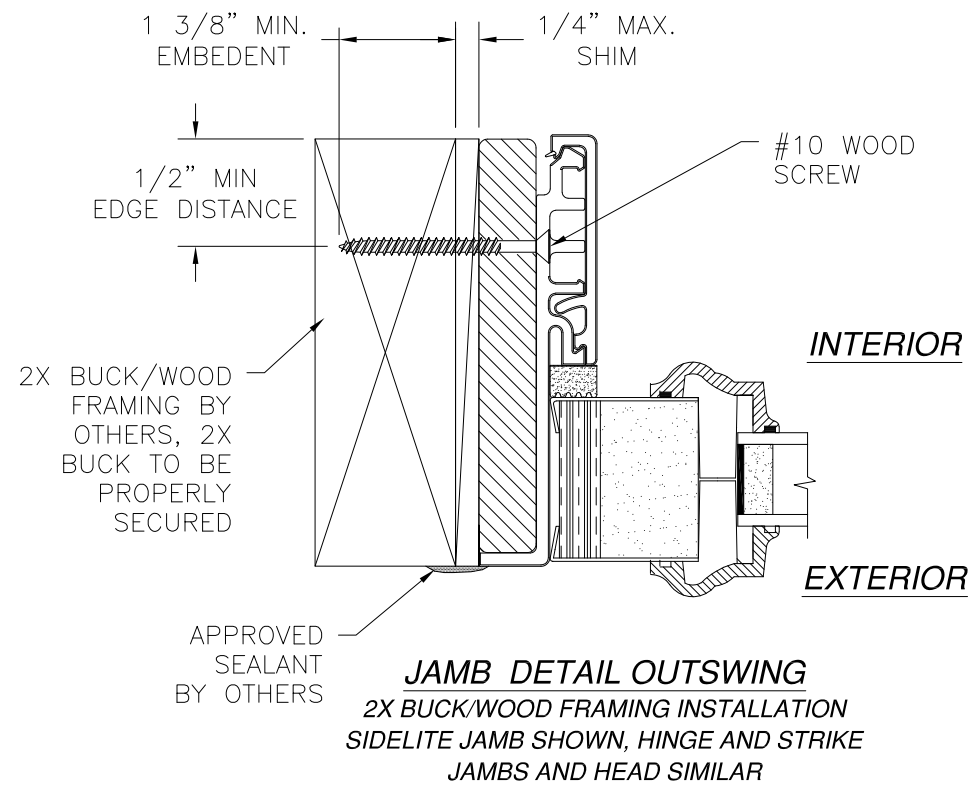

- NOTES:**
- INTERIOR AND EXTERIOR FINISHES, BY OTHERS, NOT SHOWN FOR CLARITY.
 - PERIMETER AND JOINT SEALANT BY OTHERS TO BE DESIGNED IN ACCORDANCE WITH ASTM E2112

PROVIA, LLC.
2150 STATE ROUTE 39 WEST
SUGARCREEK, OH 44681

20GA. STEEL IS OR OS DOOR W/ AND W/OUT
14" SIDELITES AND TRANSOM
INSTALLATION DETAILS W/FUSION FRAME

DRAWN: TJH	DWG NO. 08-00708	REV L
SCALE NTS	DATE 03/17/09	SHEET 12 OF 21

L. ROBERTO LOMAS P.E.
1432 WOODFORD RD LEWISVILLE, NC 27023
434-688-0609 rllomas@lrlomaspe.com

SIGNED: 09/09/2021

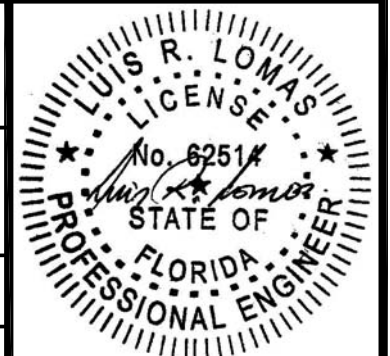

Luis R. Lomas P.E.
FL No.: 62514

REVISIONS			
REV	DESCRIPTION	DATE	APPROVED
L	ADDED COMPOSITE FRAME	09/08/2021	R.L.

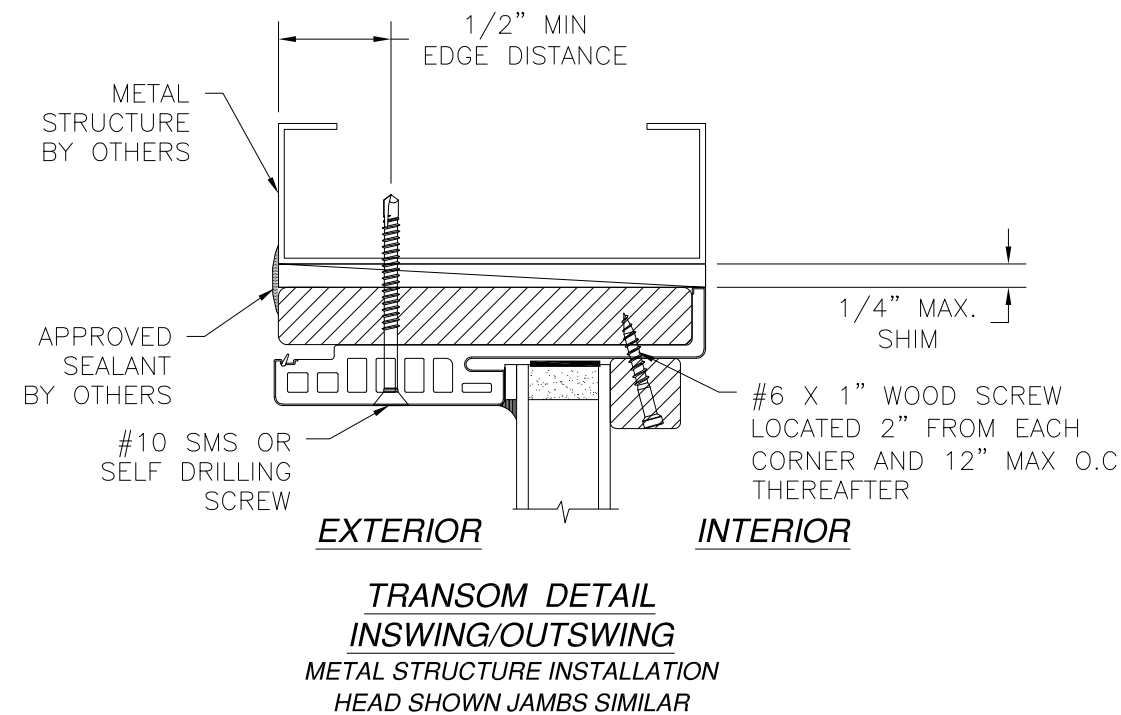
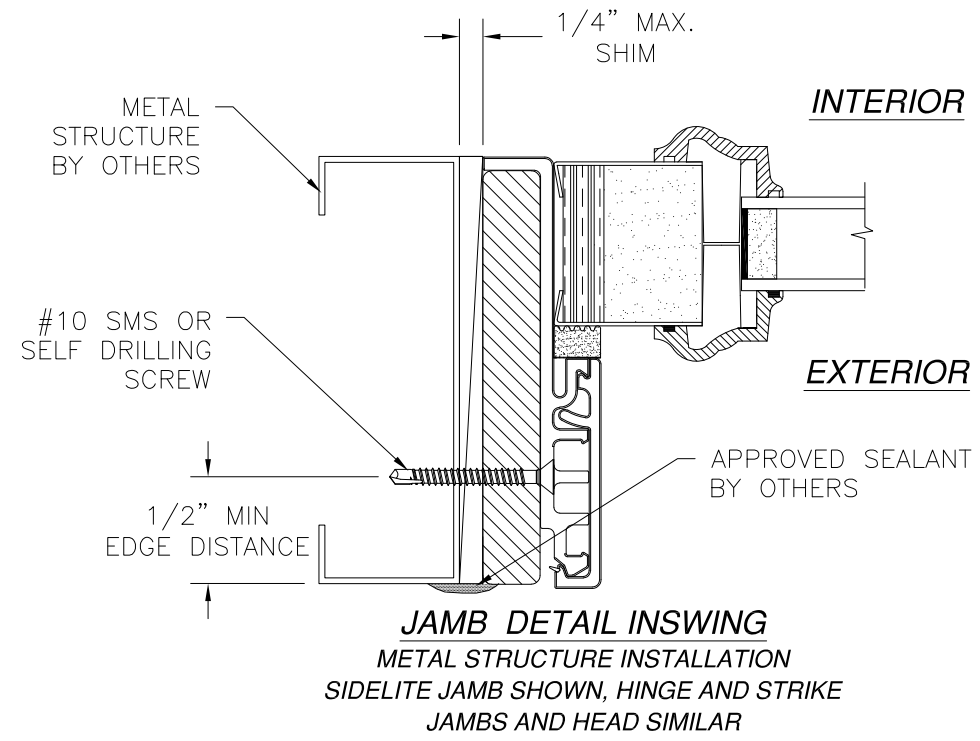
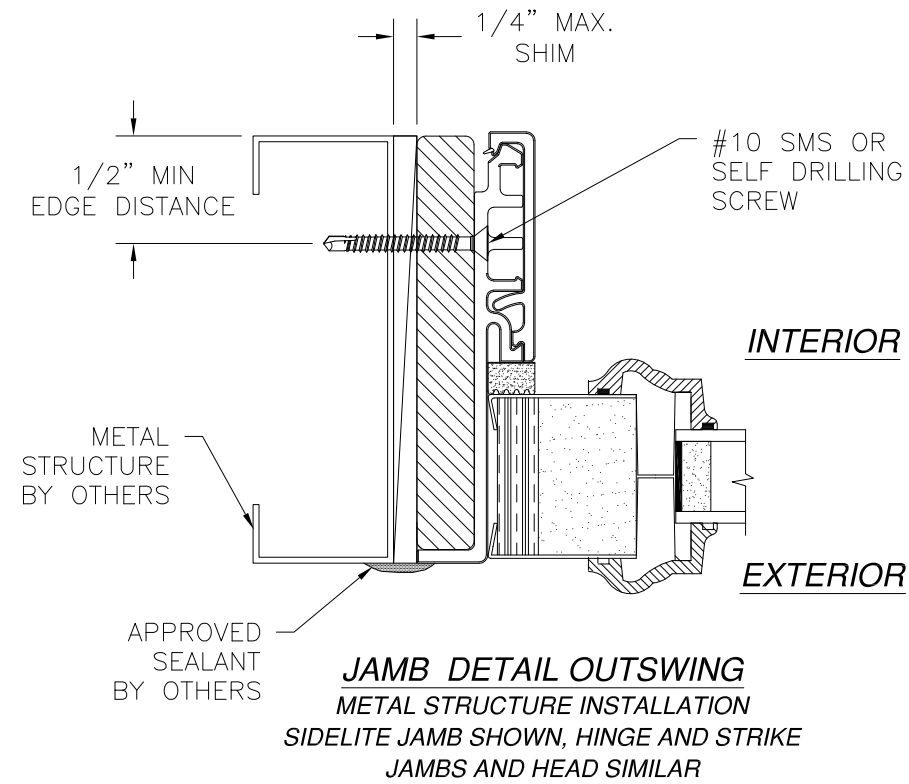

- NOTES:**
1. INTERIOR AND EXTERIOR FINISHES, BY OTHERS, NOT SHOWN FOR CLARITY.
 2. PERIMETER AND JOINT SEALANT BY OTHERS TO BE DESIGNED IN ACCORDANCE WITH ASTM E2112

PROVIA, LLC.
2150 STATE ROUTE 39 WEST
SUGARCREEK, OH 44681

20GA. STEEL IS OR OS DOOR W/ AND W/OUT
14" SIDELITES AND TRANSOM
INSTALLATION DETAILS W/FUSION FRAME

DRAWN: TJH	DWG NO. 08-00708	REV L
SCALE NTS	DATE 03/17/09	SHEET 13 OF 21

L. ROBERTO LOMAS P.E.
1432 WOODFORD RD LEWISVILLE, NC 27023
434-688-0609 rllomas@lrlomaspe.com

SIGNED: 09/09/2021



Luis R. Lomas P.E.
FL No.: 62514

REVISIONS			
REV	DESCRIPTION	DATE	APPROVED
L	ADDED COMPOSITE FRAME	09/08/2021	R.L.

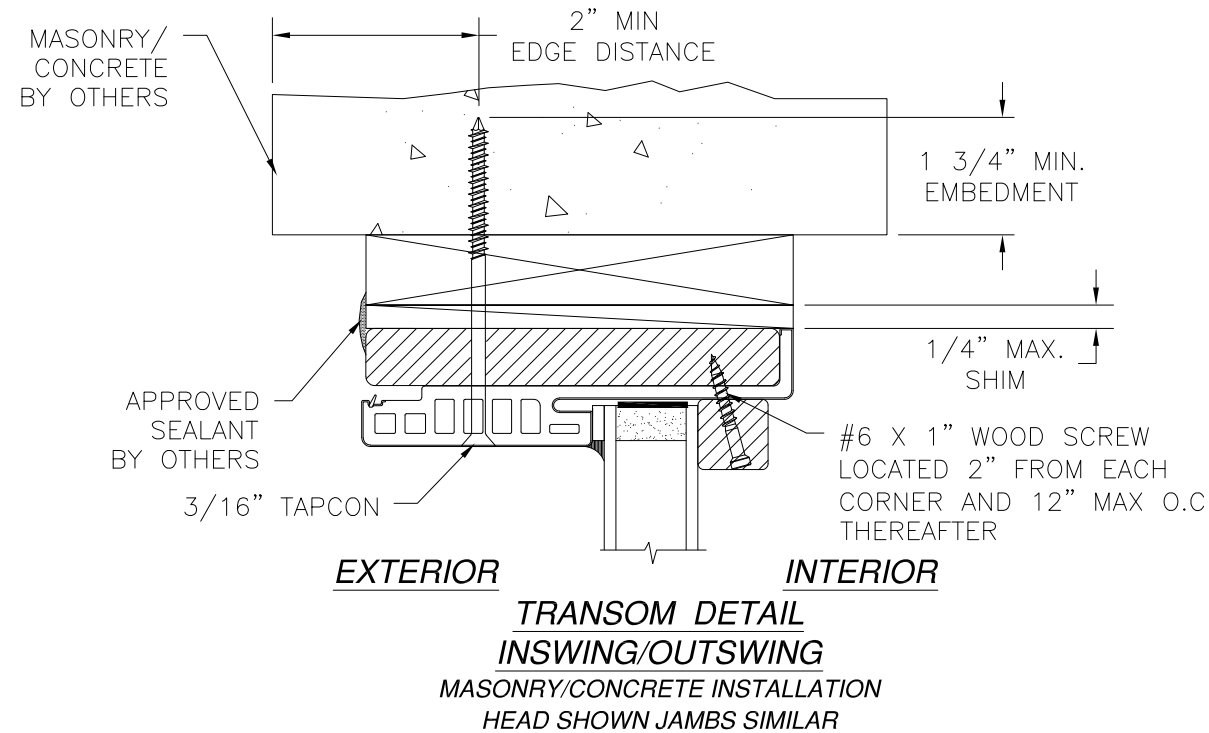
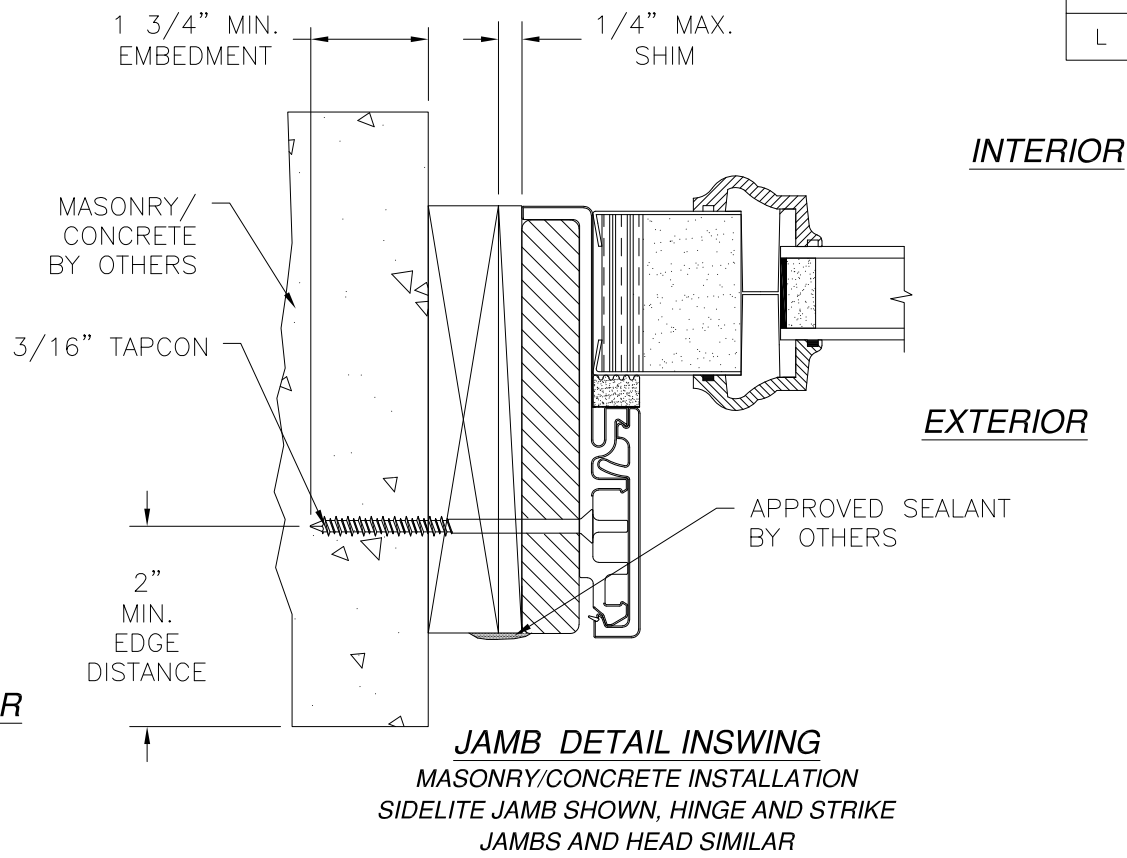
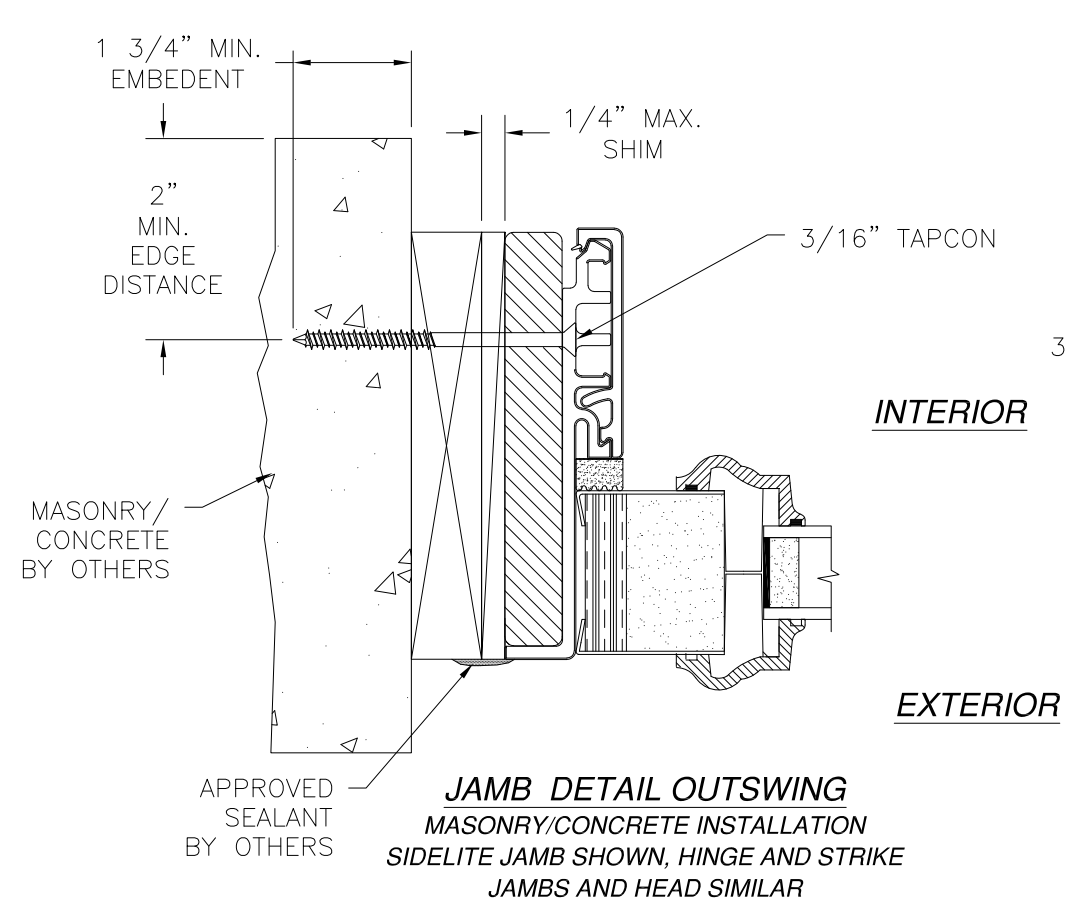

- NOTES:**
1. INTERIOR AND EXTERIOR FINISHES, BY OTHERS, NOT SHOWN FOR CLARITY.
 2. PERIMETER AND JOINT SEALANT BY OTHERS TO BE DESIGNED IN ACCORDANCE WITH ASTM E2112

PROVIA, LLC.
2150 STATE ROUTE 39 WEST
SUGARCREEK, OH 44681

20GA. STEEL IS OR OS DOOR W/ AND W/OUT
14" SIDELITES AND TRANSOM
INSTALLATION DETAILS W/FUSION FRAME

DRAWN: TJH	DWG NO. 08-00708	REV L
SCALE NTS	DATE 03/17/09	SHEET 14 OF 21

L. ROBERTO LOMAS P.E.
1432 WOODFORD RD LEWISVILLE, NC 27023
434-688-0609 rllomas@rlomaspe.com

SIGNED: 09/09/2021



Luis R. Lomas P.E.
FL No.: 62514

REVISIONS			
REV	DESCRIPTION	DATE	APPROVED
L	ADDED COMPOSITE FRAME	09/08/2021	R.L.

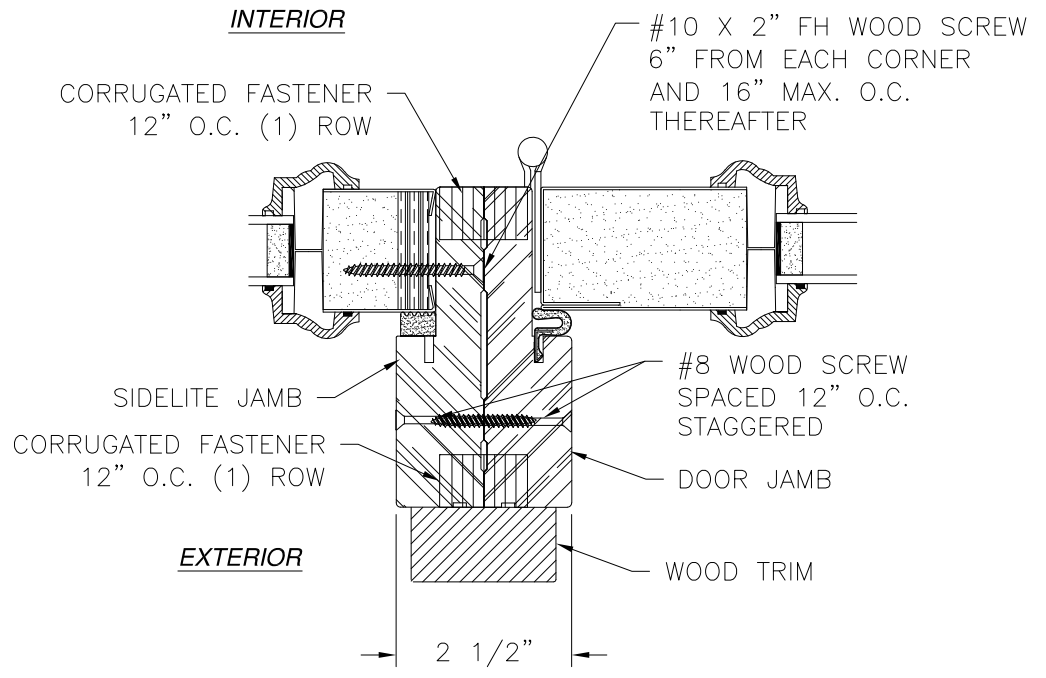

INSWING MULLION DETAIL
STANDARD FRAME SHOWN,
COMPOSITE AND FUSION FRAME SIMILAR

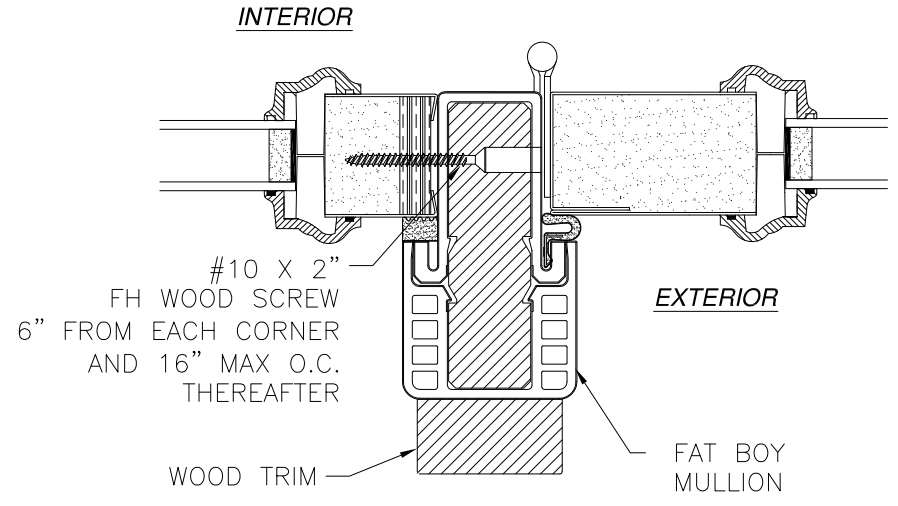

INSWING MULLION DETAIL
WITH HYBRID FAT BOY MULLION

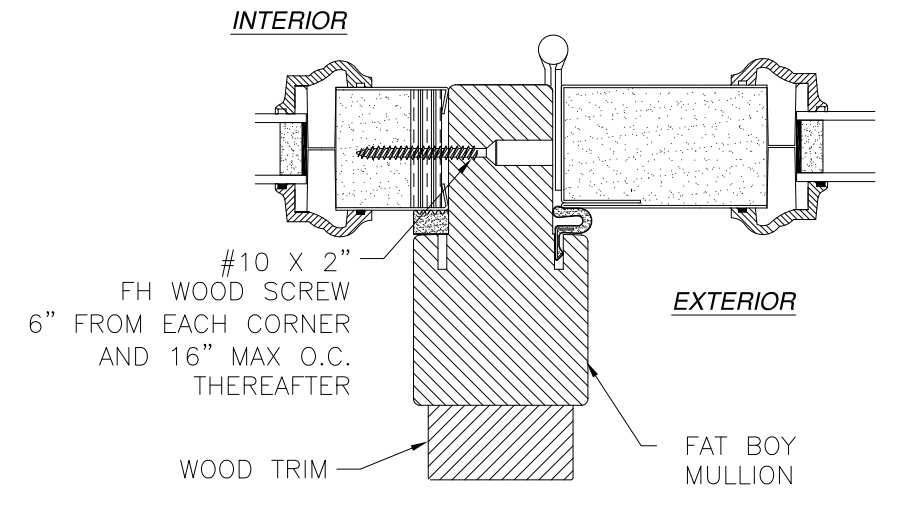

INSWING MULLION DETAIL
WITH FAT BOY MULLION

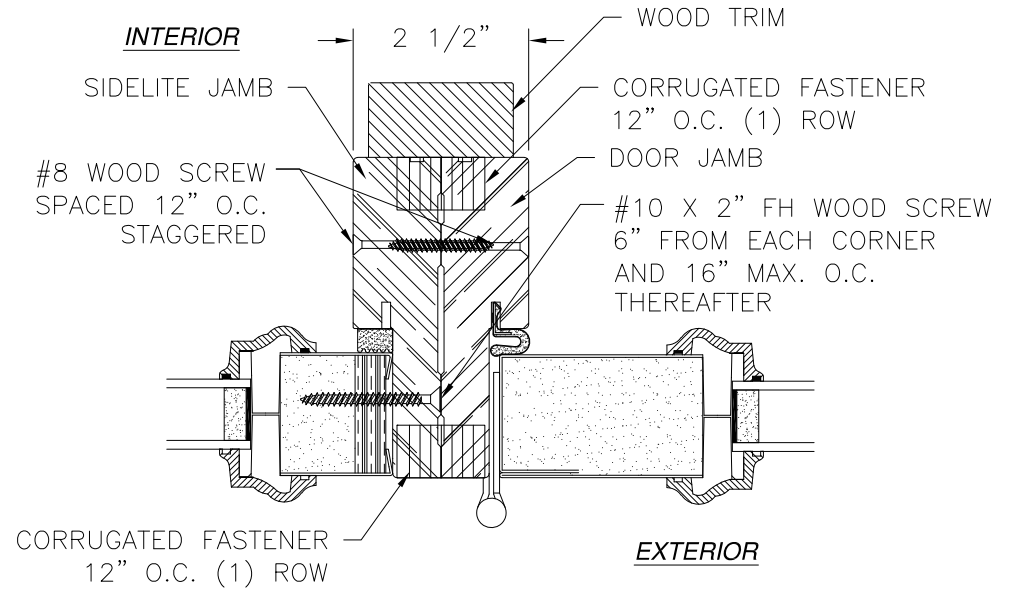

OUTSWING MULLION DETAIL
STANDARD FRAME SHOWN,
COMPOSITE AND FUSION FRAME SIMILAR

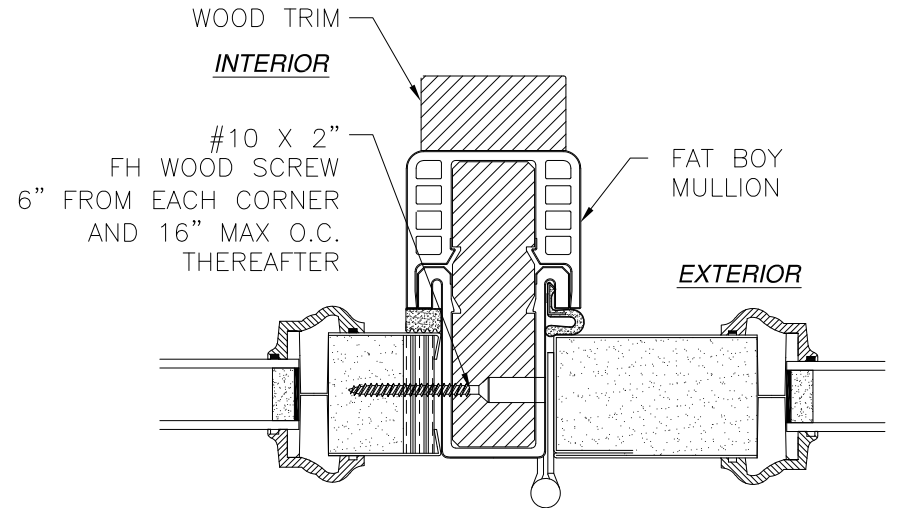

OUTSWING MULLION DETAIL
WITH HYBRID FAT BOY MULLION

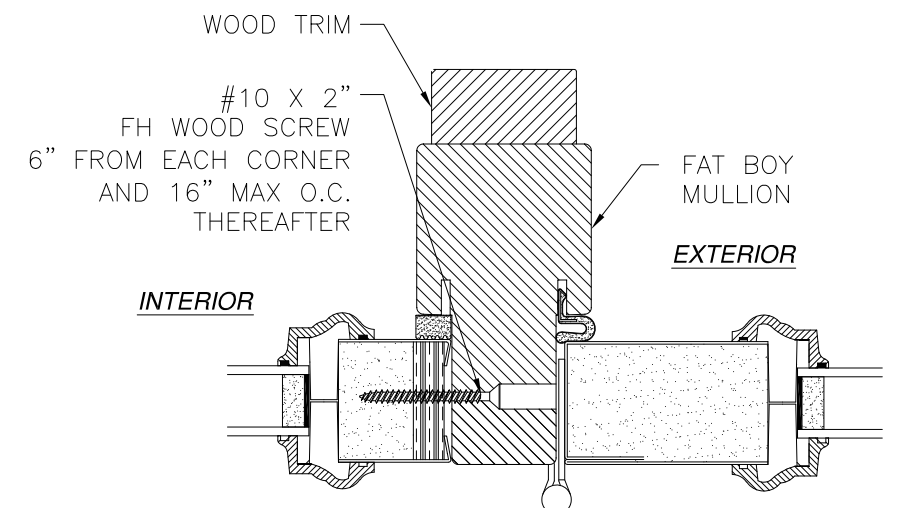

OUTSWING MULLION DETAIL
WITH FAT BOY MULLION

SIGNED: 09/09/2021

PROVIA, LLC.
2150 STATE ROUTE 39 WEST
SUGARCREEK, OH 44681

20GA. STEEL IS OR OS DOOR W/ AND W/OUT
14\"/>

DRAWN: TJH	DWG NO. 08-00708	REV L
SCALE NTS	DATE 03/17/09	SHEET 15 OF 21

L. ROBERTO LOMAS P.E.
1432 WOODFORD RD LEWISVILLE, NC 27023
434-688-0609 rllomas@rlomaspe.com

Luis R. Lomas P.E.
FL No.: 62514

REVISIONS			
REV	DESCRIPTION	DATE	APPROVED
L	ADDED COMPOSITE FRAME	09/08/2021	R.L.

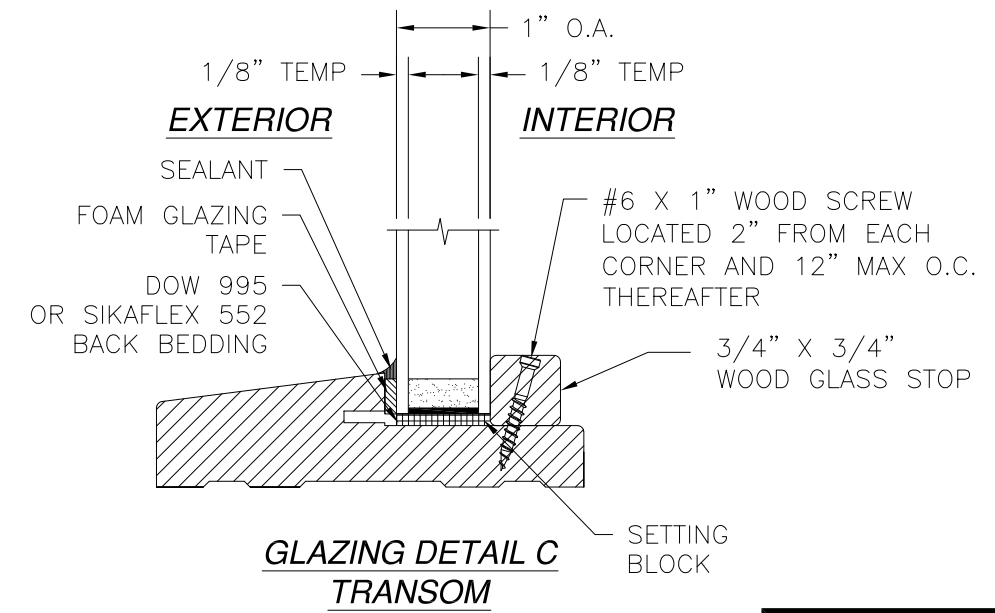
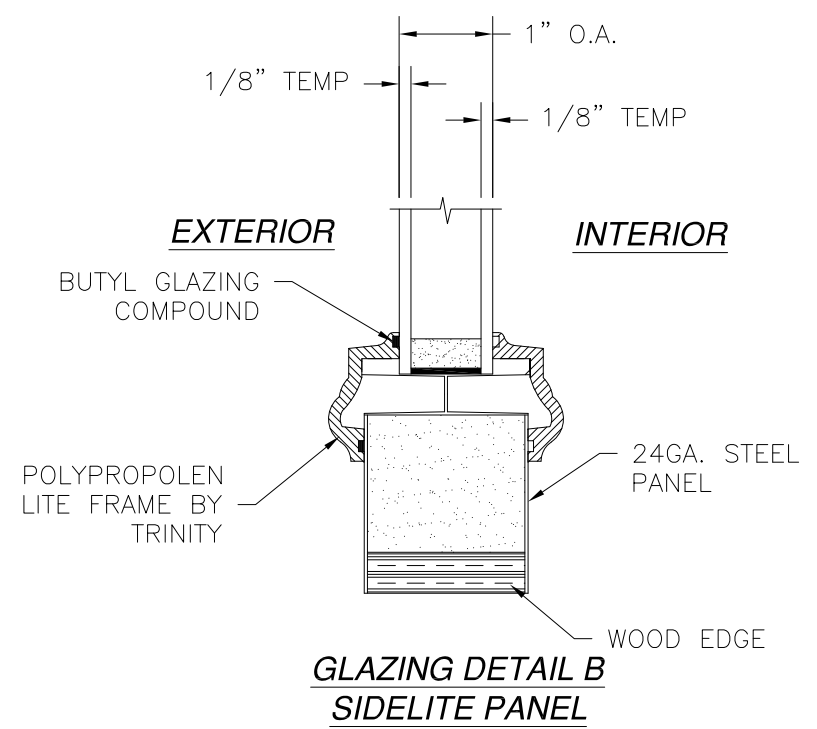
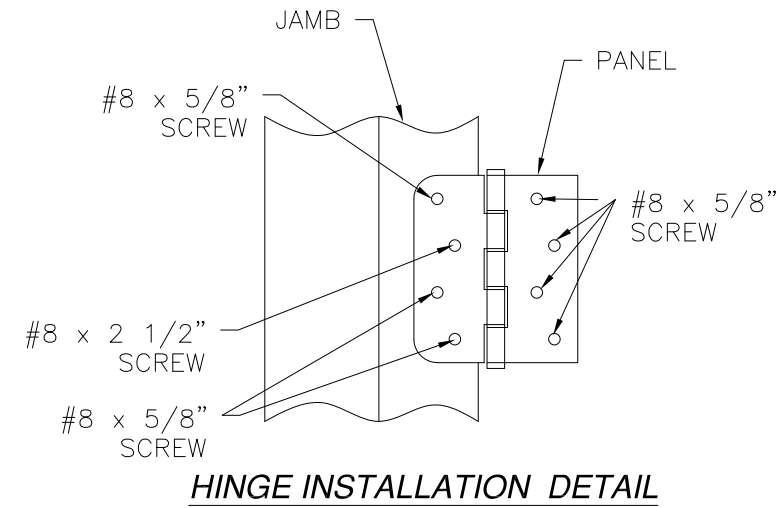
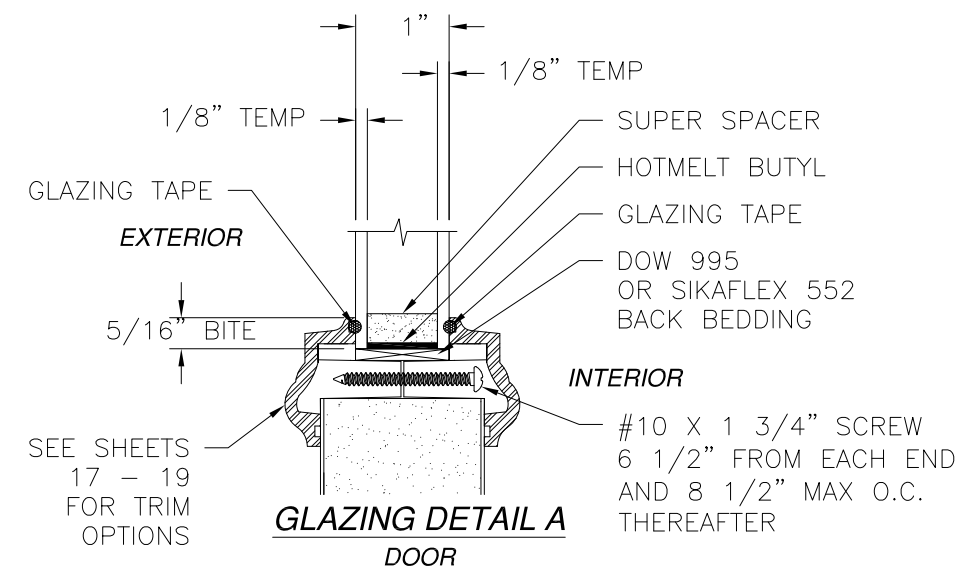

PROVIA, LLC.
2150 STATE ROUTE 39 WEST
SUGARCREEK, OH 44681

20GA. STEEL IS OR OS DOOR W/ AND W/OUT
14\"/>

SIGNED: 09/09/2021

Luis R. Lomas P.E.
FL No.: 62514

REVISIONS			
REV	DESCRIPTION	DATE	APPROVED
L	ADDED COMPOSITE FRAME	09/08/2021	R.L.

APPROVED SLABS AND TRIMS

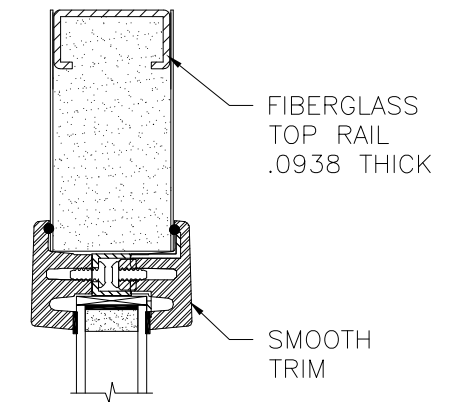
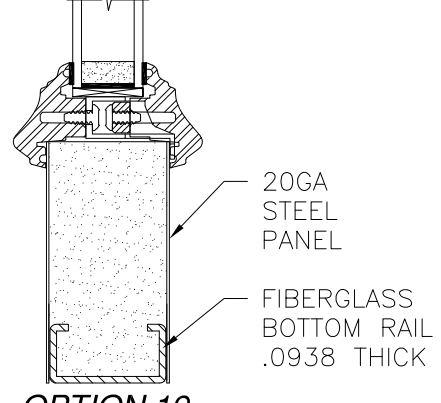
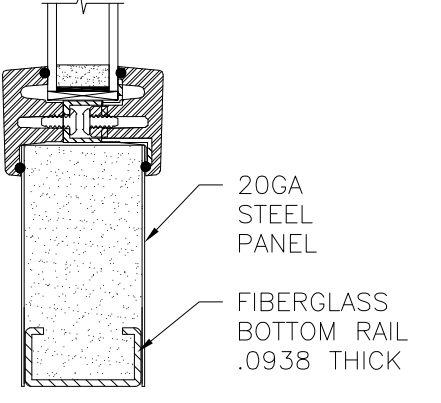
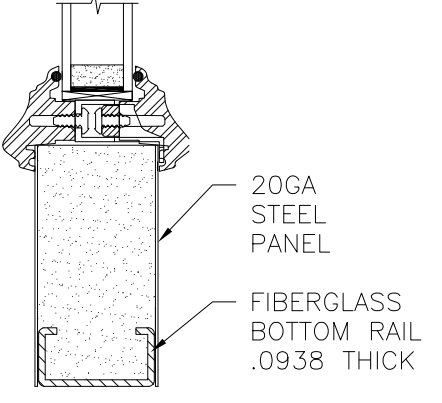
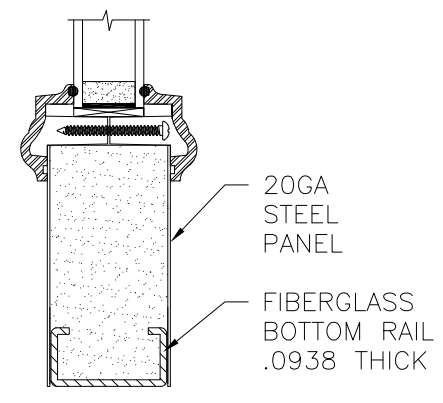
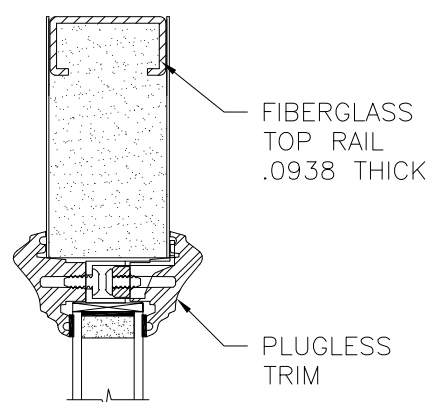
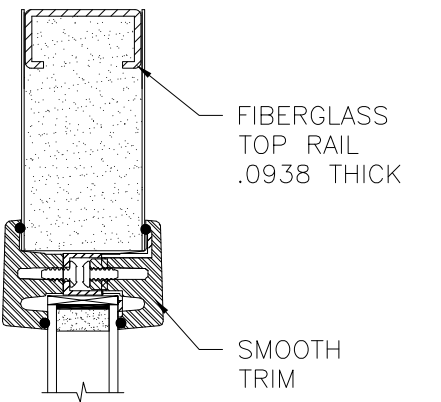
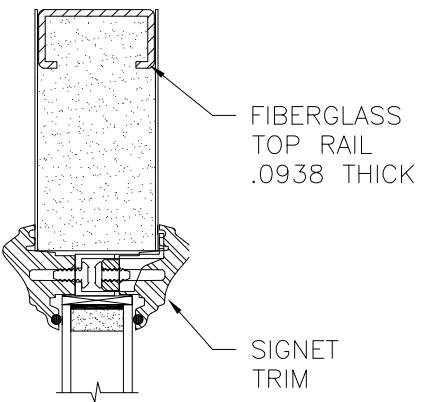
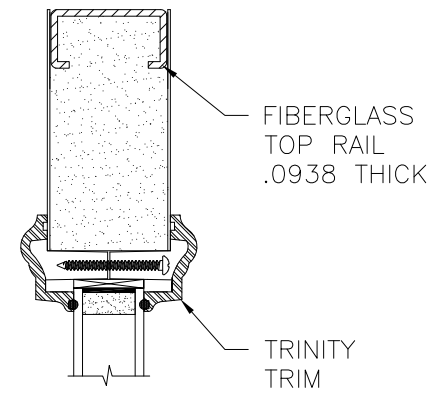

OPTION 1
TRINITY TRIM

OPTION 2
SIGNET TRIM

OPTION 3
SMOOTH TRIM

OPTION 19
PLUGLESS TRIM
W/TAPE

OPTION 21
SMOOTH TRIM
W/TAPE

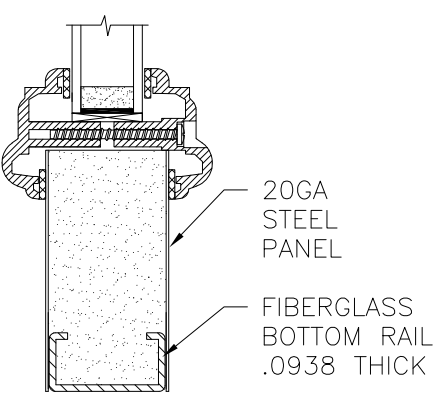
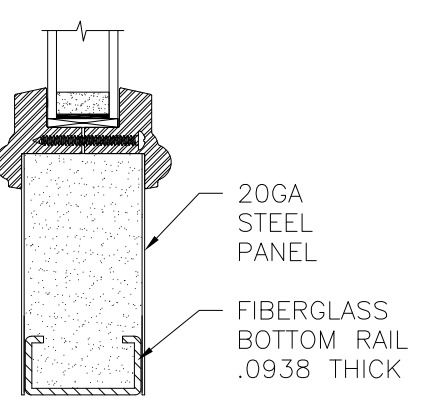
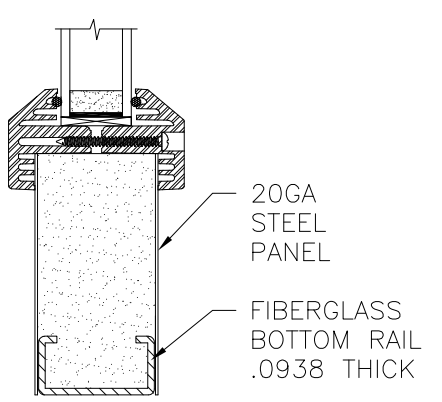
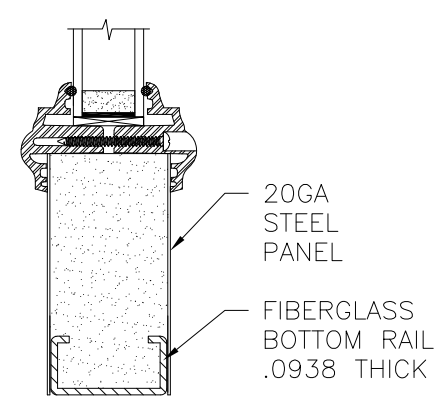
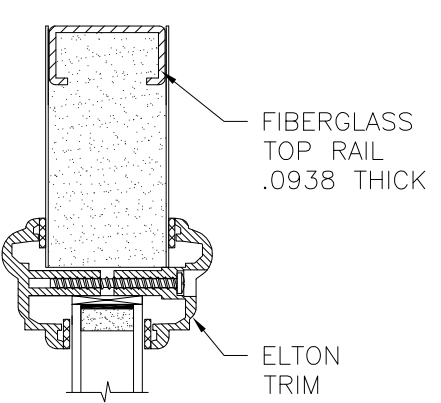
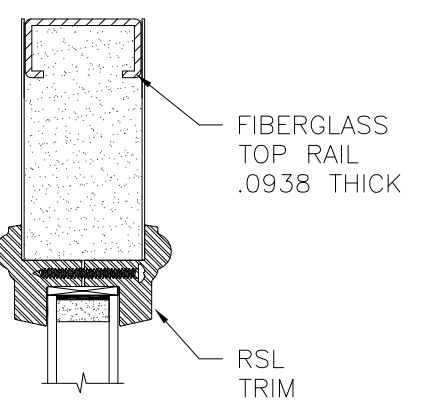
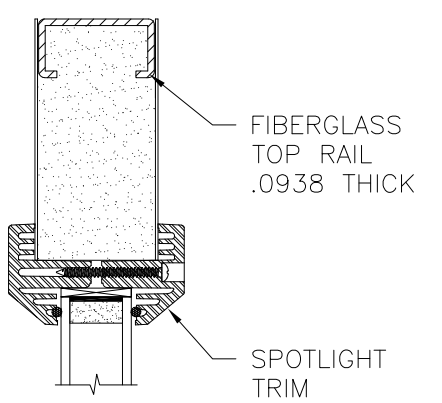
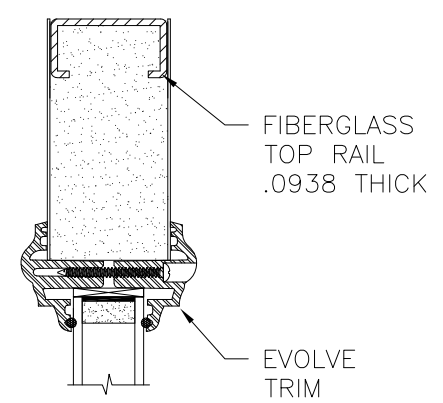

OPTION 4
EVOLVE TRIM

OPTION 5
SPOTLIGHT TRIM

OPTION 6
RSL TRIM

OPTION 20
ELTON TRIM

PROVIA, LLC.
2150 STATE ROUTE 39 WEST
SUGARCREEK, OH 44681

20GA. STEEL IS OR OS DOOR W/ AND W/OUT
14" SIDELITES AND TRANSOM
APPROVED SLABS AND TRIMS

DRAWN: TJH	DWG NO. 08-00708	REV L
SCALE NTS	DATE 03/17/09	SHEET 17 OF 21

L. ROBERTO LOMAS P.E.
1432 WOODFORD RD LEWISVILLE, NC 27023
434-688-0609 rllomas@rlomaspe.com

SIGNED: 09/09/2021



Luis R. Lomas P.E.
FL No.: 62514

REVISIONS			
REV	DESCRIPTION	DATE	APPROVED
L	ADDED COMPOSITE FRAME	09/08/2021	R.L.

APPROVED SLABS AND TRIMS

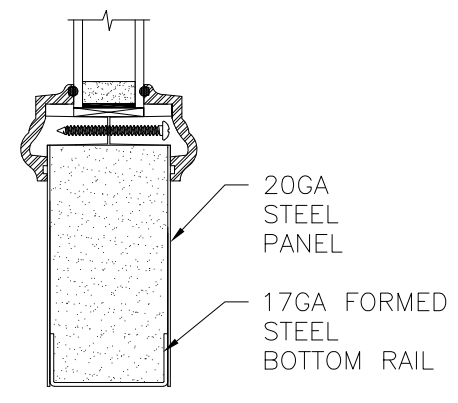
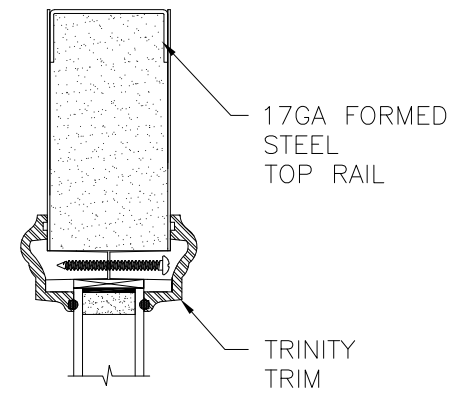

OPTION 7
TRINITY TRIM

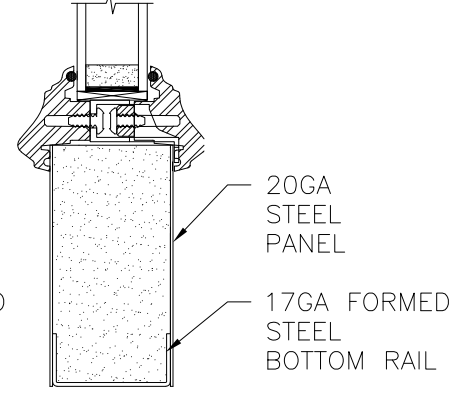
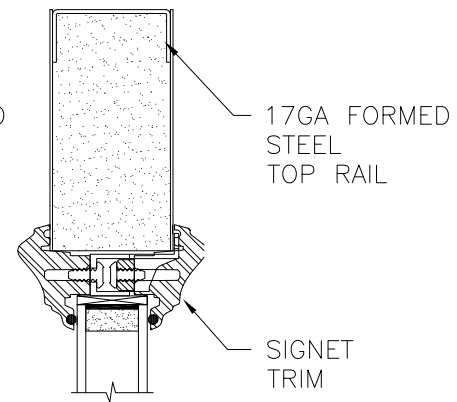

OPTION 8
SIGNET TRIM

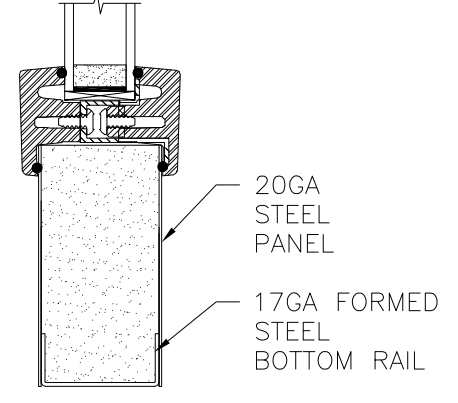
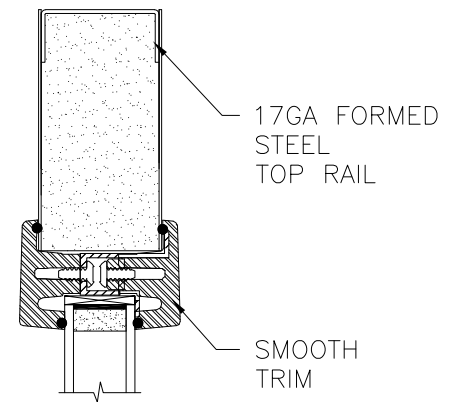

OPTION 9
SMOOTH TRIM

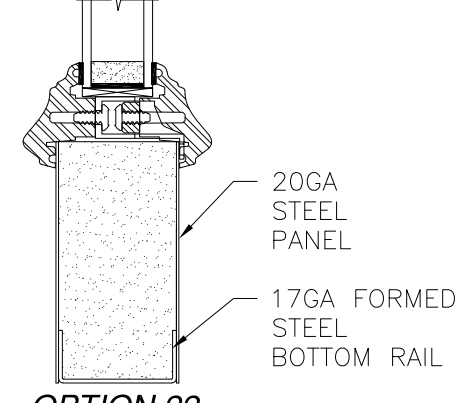
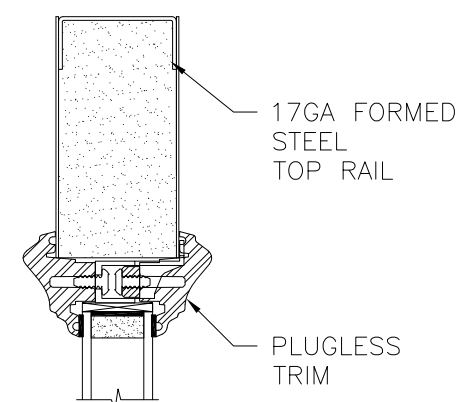

OPTION 22
PLUGLESS TRIM
W/TAPE

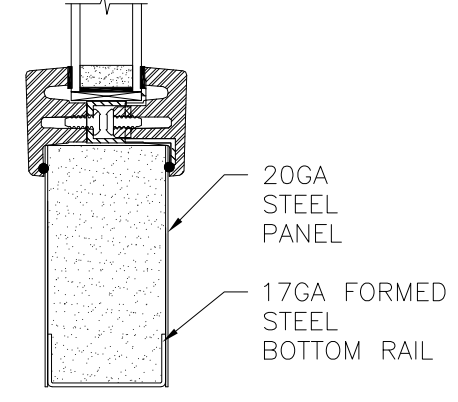
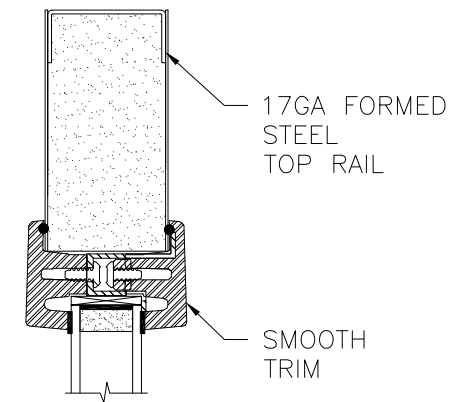

OPTION 24
SMOOTH TRIM
W/TAPE

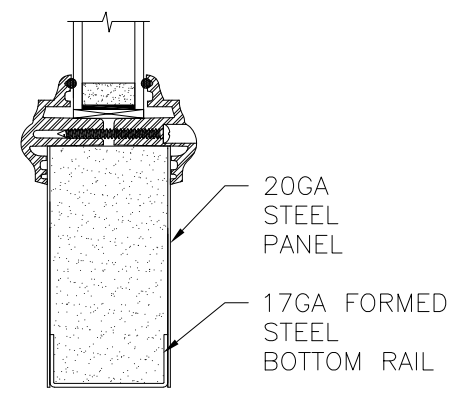
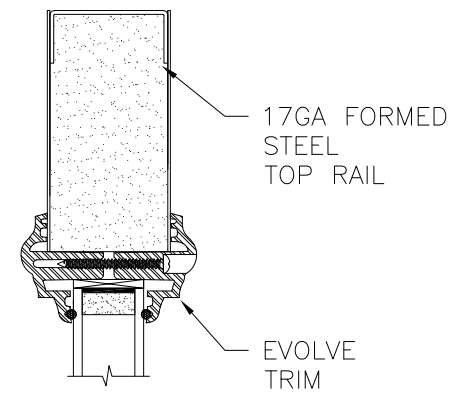

OPTION 10
EVOLVE TRIM

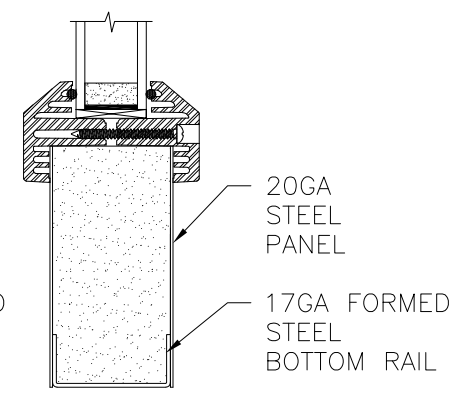
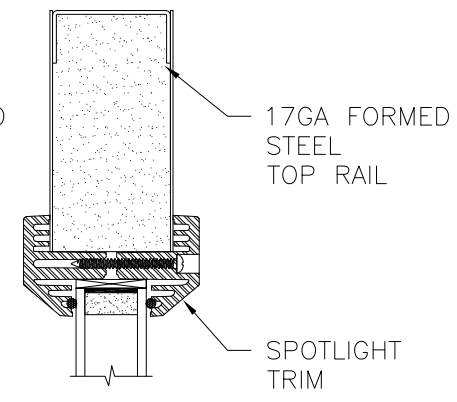

OPTION 11
SPOTLIGHT TRIM

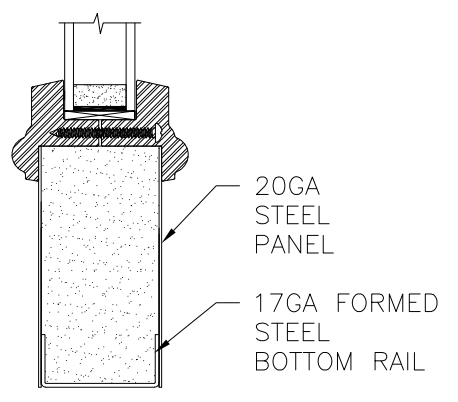
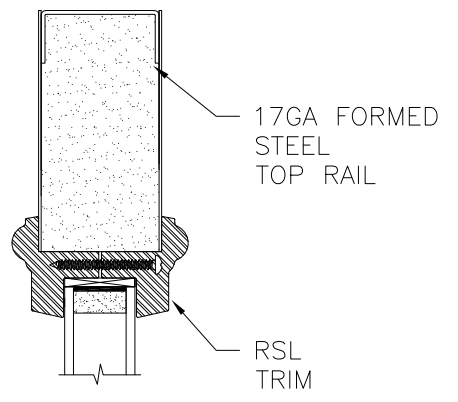

OPTION 12
RSL TRIM

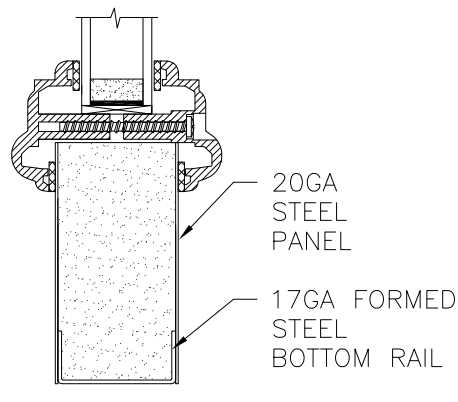
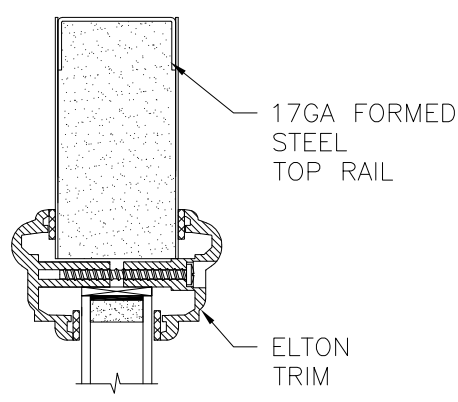

OPTION 23
ELTON TRIM

SIGNED: 09/09/2021

PROVIA, LLC.
2150 STATE ROUTE 39 WEST
SUGARCREEK, OH 44681

20GA. STEEL IS OR OS DOOR W/ AND W/OUT
14" SIDELITES AND TRANSOM
APPROVED SLABS AND TRIMS

DRAWN: TJH	DWG NO. 08-00708	REV L
SCALE NTS	DATE 03/17/09	SHEET 18 OF 21

L. ROBERTO LOMAS P.E.
1432 WOODFORD RD LEWISVILLE, NC 27023
434-688-0609 rllomas@rlomaspe.com



Luis R. Lomas P.E.
FL No.: 62514

REVISIONS			
REV	DESCRIPTION	DATE	APPROVED
L	ADDED COMPOSITE FRAME	09/08/2021	R.L.

APPROVED SLABS AND TRIMS

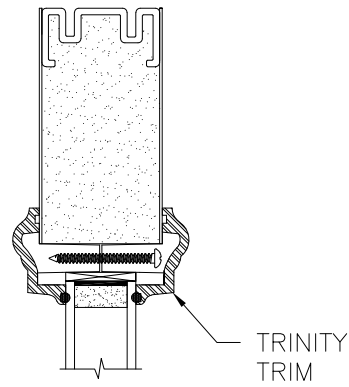

TRINITY TRIM

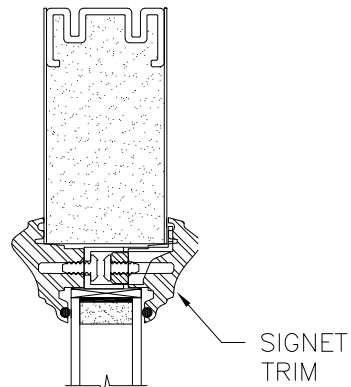

SIGNET TRIM

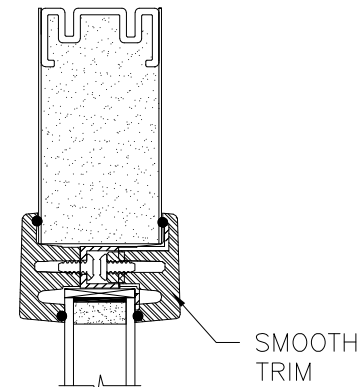

SMOOTH TRIM

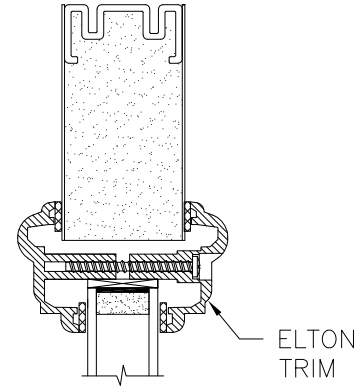

ELTON TRIM

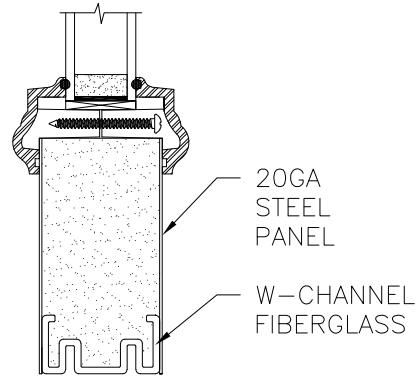

20GA STEEL PANEL
W-CHANNEL FIBERGLASS

OPTION 13
TRINITY TRIM

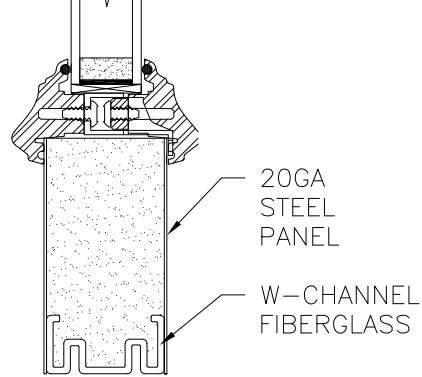

20GA STEEL PANEL
W-CHANNEL FIBERGLASS

OPTION 14
SIGNET TRIM

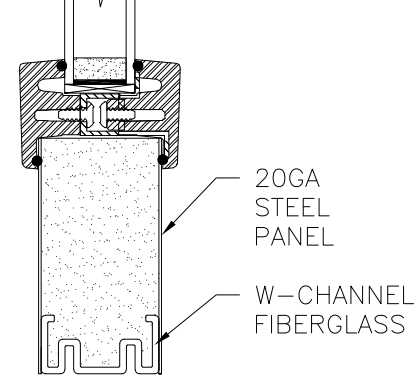

20GA STEEL PANEL
W-CHANNEL FIBERGLASS

OPTION 15
SMOOTH TRIM

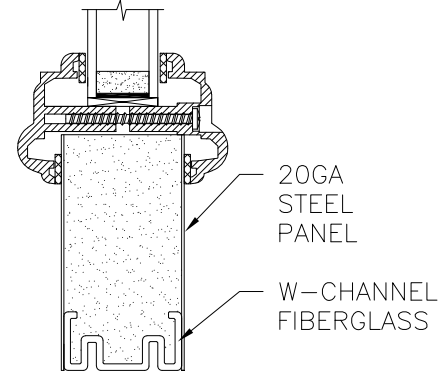

20GA STEEL PANEL
W-CHANNEL FIBERGLASS

OPTION 25
ELTON TRIM

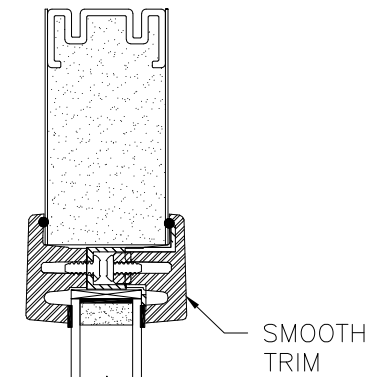

SMOOTH TRIM

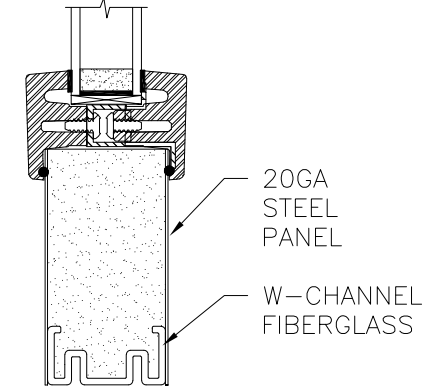

20GA STEEL PANEL
W-CHANNEL FIBERGLASS

OPTION 27
SMOOTH TRIM
W/TAPE

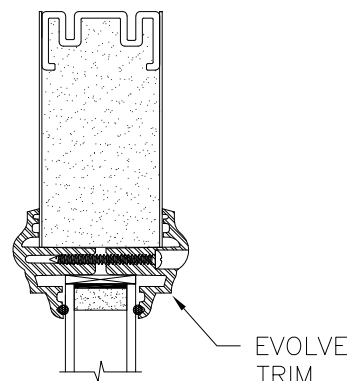

EVOLVE TRIM

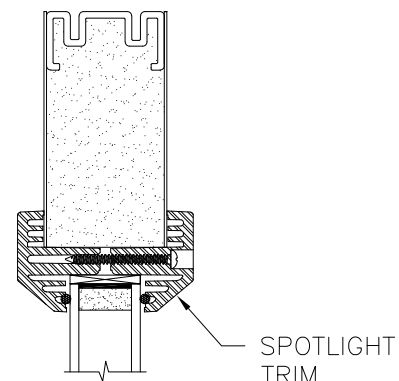

SPOTLIGHT TRIM

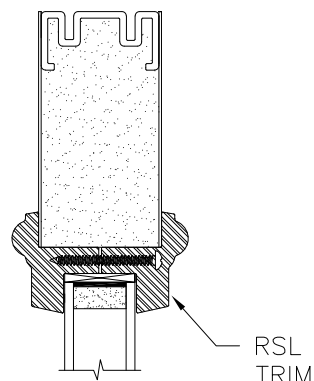

RSL TRIM

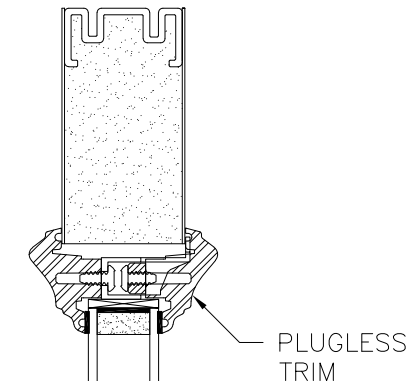

PLUGLESS TRIM

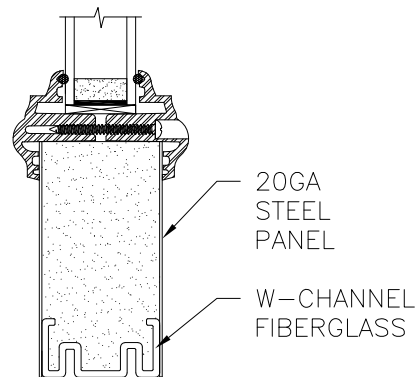

20GA STEEL PANEL
W-CHANNEL FIBERGLASS

OPTION 16
EVOLVE TRIM

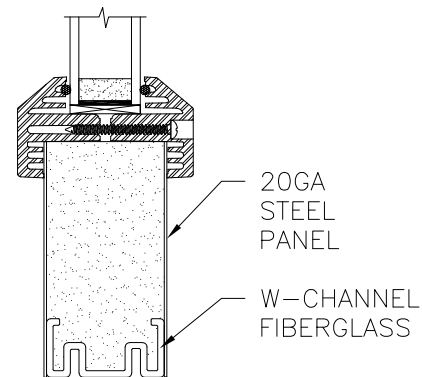

20GA STEEL PANEL
W-CHANNEL FIBERGLASS

OPTION 17
SPOTLIGHT TRIM

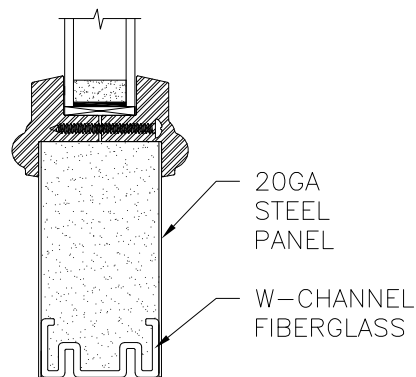

20GA STEEL PANEL
W-CHANNEL FIBERGLASS

OPTION 18
RSL TRIM

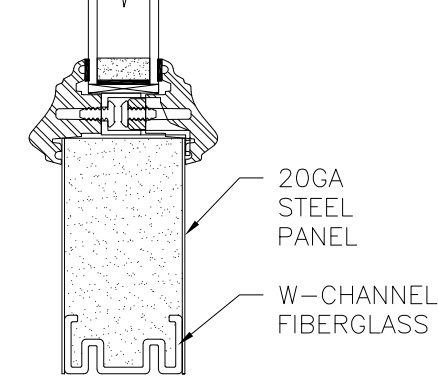

20GA STEEL PANEL
W-CHANNEL FIBERGLASS

OPTION 26
PLUGLESS TRIM
W/TAPE

SIGNED: 09/09/2021

PROVIA, LLC.

2150 STATE ROUTE 39 WEST
SUGARCREEK, OH 44681

20GA. STEEL IS OR OS DOOR W/ AND W/OUT
14" SIDELITES AND TRANSOM
APPROVED SLABS AND TRIMS

DRAWN: TJH	DWG NO. 08-00708	REV L
SCALE NTS	DATE 03/17/09	SHEET 19 OF 21

L. ROBERTO LOMAS P.E.
1432 WOODFORD RD LEWISVILLE, NC 27023
434-688-0609 rllomas@rlomaspe.com



Luis R. Lomas P.E.
FL No.: 62514

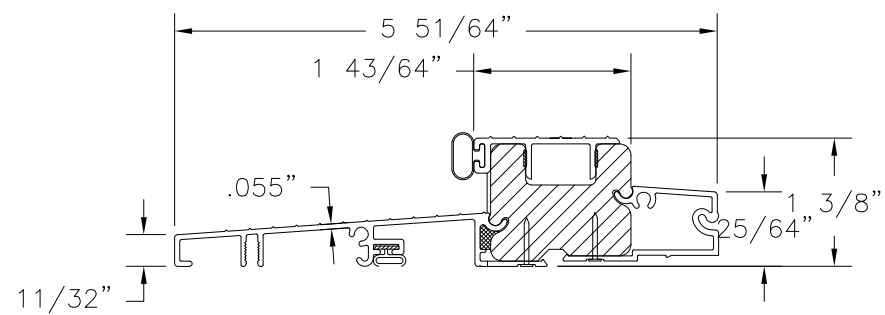

OUTSWING SILL

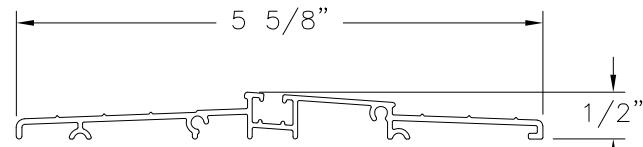

ADA OUTSWING THRESHOLD

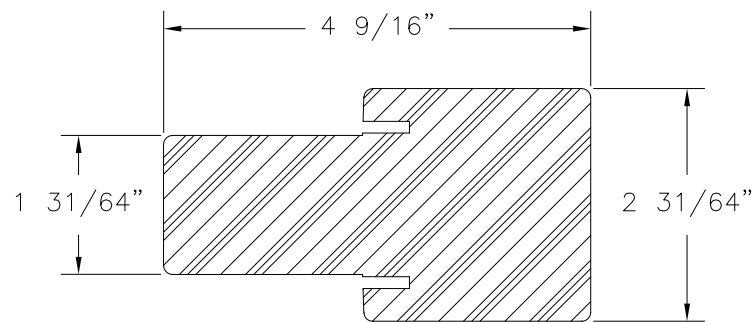

**FAT BOY MULLION
COMPOSITE**

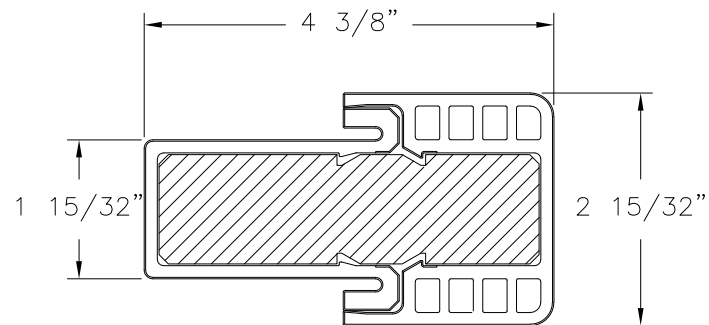

**HYBRID FAT BOY MULLION
COMPOSITE**

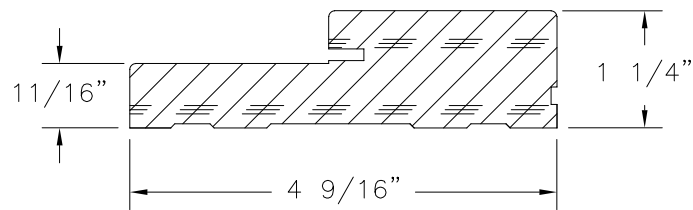

**FRAME
WOOD G.46 MIN.**

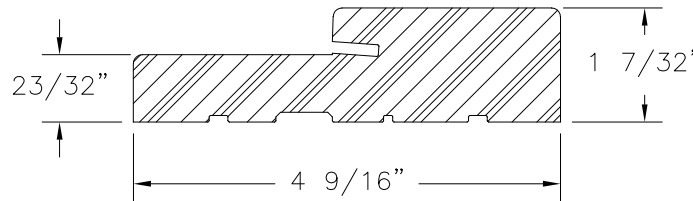

**FRAMESAVER
COMPOSITE**

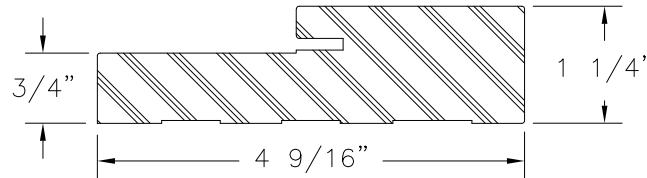

**FRAME
COMPOSITE**

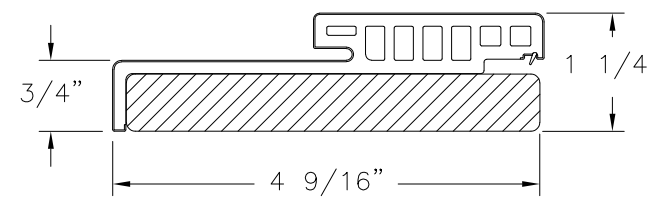

**HYBRID HEAD
WOOD/COMPOSITE**

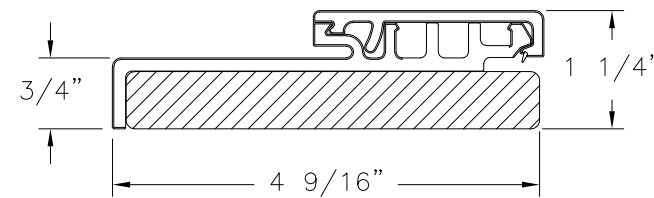

**HYBRID JAMB
WOOD/COMPOSITE**

REVISIONS			
REV	DESCRIPTION	DATE	APPROVED
L	ADDED COMPOSITE FRAME	09/08/2021	R.L.

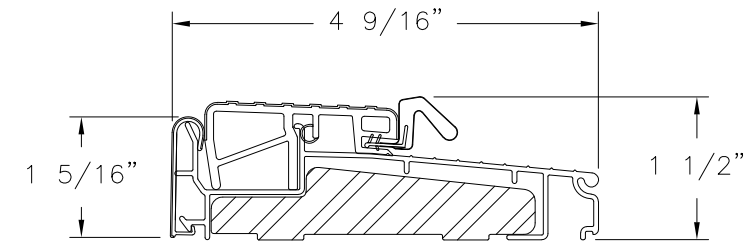

OUTSWING SILL ZOBL4565

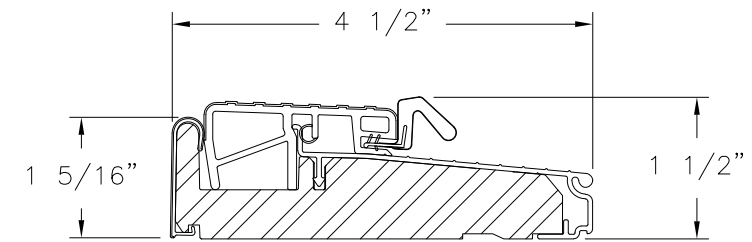

OUTSWING SILL ZOB4565F

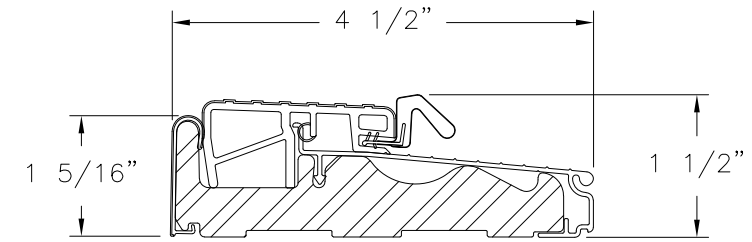

OUTSWING SILL ZOBLH4565

SIGNED: 09/09/2021

PROVIA, LLC.

2150 STATE ROUTE 39 WEST
SUGARCREEK, OH 44681

20GA. STEEL IS OR OS DOOR W/ AND W/OUT
14" SIDELITES AND TRANSOM
COMPONENTS

DRAWN: TJH	DWG NO. 08-00708	REV L
SCALE NTS	DATE 03/17/09	SHEET 20 OF 21

L. ROBERTO LOMAS P.E.
1432 WOODFORD RD LEWISVILLE, NC 27023
434-688-0609 rllomas@rlomaspe.com

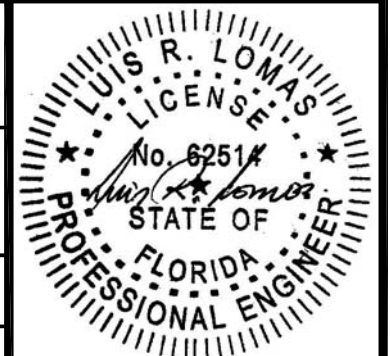

Luis R. Lomas P.E.
FL No.: 62514

REVISIONS			
REV	DESCRIPTION	DATE	APPROVED
L	ADDED COMPOSITE FRAME	09/08/2021	R.L.

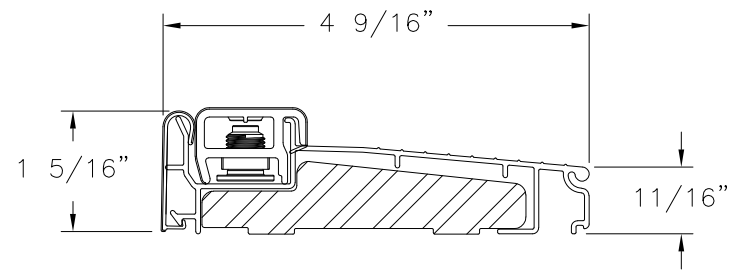

INSWING SILL ZAIL4565

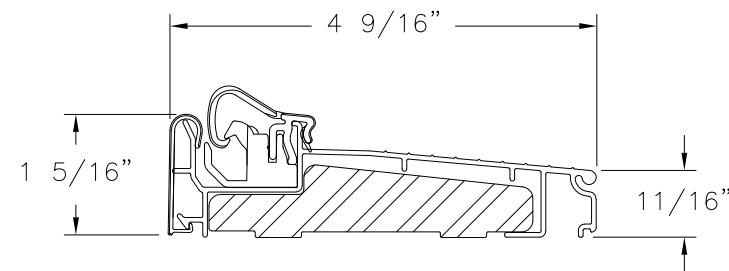

INSWING SILL ZAQL4565

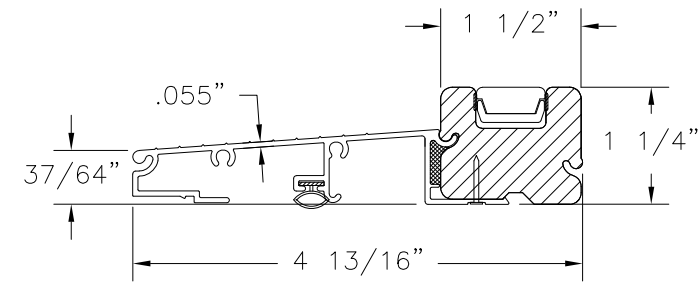

INSWING SILL

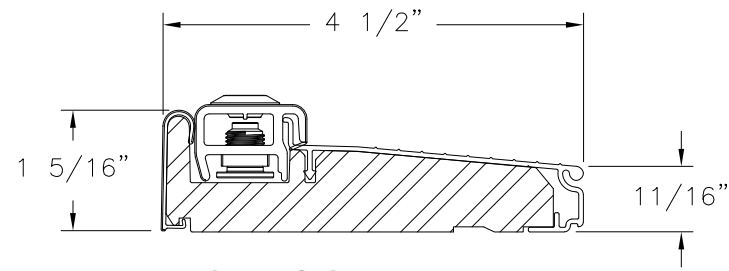

INSWING SILL ZAI4565F

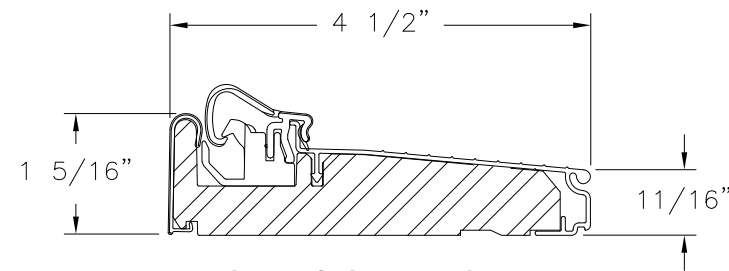

INSWING SILL ZAC4565F

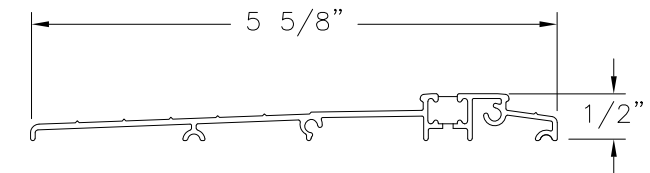

ADA INSWING THRESHOLD

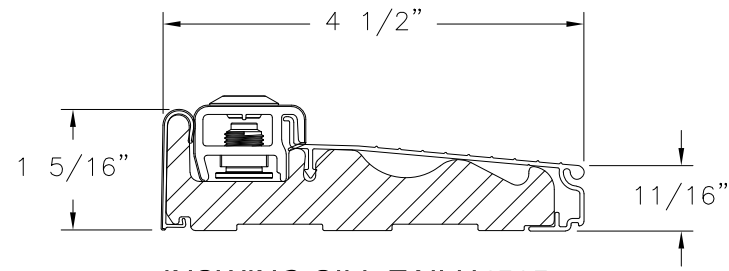

INSWING SILL ZAILH4565

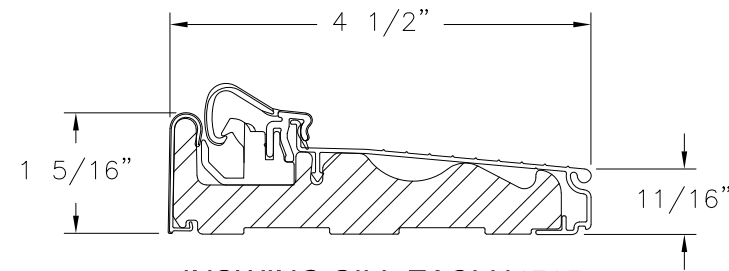

INSWING SILL ZAQLH4565

SIGNED: 09/09/2021

PROVIA, LLC. 2150 STATE ROUTE 39 WEST SUGARCREEK, OH 44681		
20GA. STEEL IS OR OS DOOR W/ AND W/OUT 14" SIDELITES AND TRANSOM COMPONENTS		
DRAWN: TJH	DWG NO. 08-00708	REV L
SCALE NTS	DATE 03/17/09	SHEET 21 OF 21
L. ROBERTO LOMAS P.E. 1432 WOODFORD RD LEWISVILLE, NC 27023 434-688-0609 rllomas@rlomaspe.com		

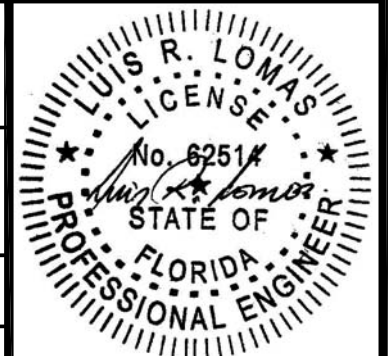

Luis R. Lomas P.E.
FL No.: 62514