

**EVALUATION REPORT OF  
CENTRAL STATES MANUFACTURING, INC.  
'26 GA. PANEL-LOC PLUS PANEL'**

**FLORIDA BUILDING CODE 7TH EDITION (2020)  
FLORIDA PRODUCT APPROVAL  
FL 14026.3-R5  
ROOFING  
METAL ROOFING**

**Prepared For:  
Central States Manufacturing, Inc.  
302 Jane Place  
Lowell, AR 72745  
Telephone: (800) 356-2733  
Fax: (800) 356-2971**

**Prepared By:  
Bala Sockalingam, Ph.D., P.E.  
Florida Professional Engineer #62240  
1216 N Lansing Ave., Suite C  
Tulsa, OK 74106  
Telephone: (918) 492-5992  
FAX: (866) 366-1543**

**This report consists of  
Evaluation Report (3 Pages including cover)  
Installation Details (1 Page)**

**Report No. C2399-3  
Date: 9.30.2020**



Manufacturer: Central States Manufacturing, Inc.

Product Name: Panel-Loc Plus Panel

Panel Description: 36" wide coverage with (5) 3/4" high ribs

Materials: Min. 26 ga., 80 ksi steel or min. 24 ga., 50 ksi steel. Galvanized coated steel (ASTM A653) or Galvalume coated steel (ASTM A792) or painted steel (ASTM A755). Corrosion resistant as per FBC 2020 Section 1507.4.3.

Deck Description: Min. 15/32" thick APA rated plywood or min. 3/4" thick wood plank (min SG of 0.42) for new and existing constructions. For HVHZ, min. 19/32" thick plywood for new constructions and min. 15/32" thick plywood for existing constructions. Designed by others and installed as per FBC 2020.

Deck Attachment: (Minimum) 8d x 2.5" long ring shank nails or #8 x 2" long wood screws at 6" o.c. in the plywood field and edges.

Underlayment: Minimum underlayment as per FBC 2020 Section 1507.4.5.1. For HVHZ, minimum underlayment as per FBC 2020 Section 1518.2, 1518.3 and 1518.4.

Slope: 1/2:12 or greater in accordance with FBC 2020 Section 1507.4.2. For HVHZ, 2:12 or greater in accordance with FBC 2020 Section 1515.2.

Design Uplift Pressure: (Factor of Safety = 2) 101.0 psf at fastener spacing of 24 o.c.  
168.5 psf at fastener spacing of 12 o.c.

Panel Attachment: #10 x 1.5" long Kwikseal II Woodbinder screws with sealing washer or approved equal. Fastener shall be of sufficient length to penetrate through the deck a minimum of 1/4" and spaced at 6"-3"-6" o.c. across panel width at all locations. Fasteners are corrosion resistant as per FBC 2020 Section 1507.4.4.

Sidelap Attachment: 1/4"-14 x 3/4" long hex-head lap screws at 24" o.c. Required for roof slope less than 3:12. Fasteners are corrosion resistant as per FBC 2020 Section 1507.4.4.

Test Standards: Roof assembly tested in accordance with TAS 125-03 'Standard Requirements for Metal Roofing Systems', TAS 100-95 'Test Procedure for Wind and Wind Driven Rain Resistance of Discontinuous Roof Systems' and TAS 110-00 'Testing Requirements

for Physical Properties of Roof Membrane, Insulation, Coatings and Other Roofing Components’.

Code Compliance: The product described herein has demonstrated compliance with FBC 2020 Section 1504.3, 1507.4, 1518.9 and 1523.6.5.2.4.

Product Limitations: Design wind loads shall be determined for each project in accordance with FBC 2020 Section 1620 or ASCE 7-16 using allowable stress design. The maximum fastener spacing listed herein shall not be exceeded. Panels will be installed as per manufacturer’s installation guideline and RAS 133. This evaluation report is applicable in High Velocity Hurricane Zone. Fire classification is not within scope of this Evaluation Report. Refer to a current NOA fire directory listing for fire ratings of this roofing system assembly as well as the location of the fire barrier within the assembly.

Supporting Documents: TAS 125-03 Test Report  
Force Engineering and Testing Inc.  
Report No. 410-0226T-11A-C, Reporting Date 11/14/2011

TAS 100-95 Test Report  
Farabaugh Engineering & Testing, Inc.  
Report No. T330-11, Reporting Date 11/10/2011

TAS 110-00 Test Report on Valspar Fluoropon coated metal panels  
PRI Asphalt Technologies  
Report No. VLS-005-02-01, Reporting Date 2/22/2013

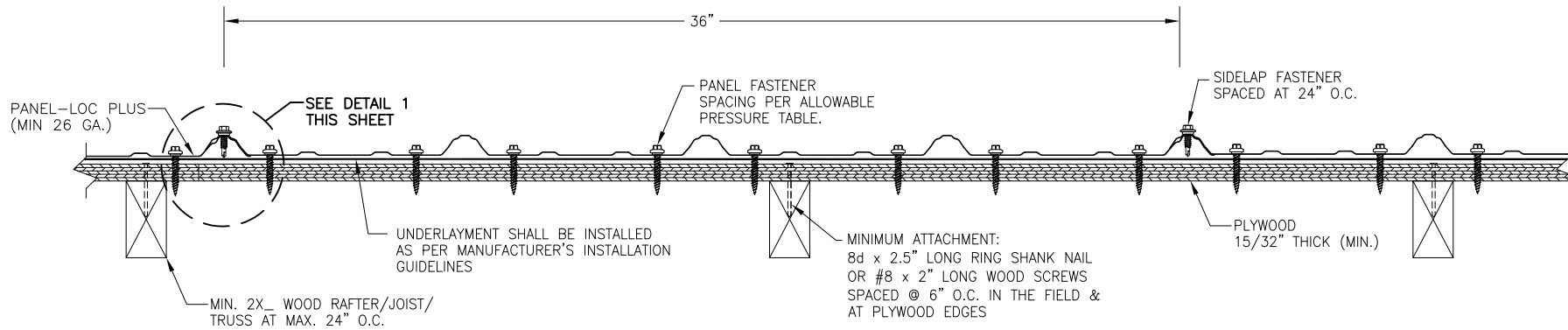

### TYPICAL PANEL INSTALLATION X-SECTION

#### ALLOWABLE UPLIFT PRESSURE

FASTENER SPACING (IN)	PRESSURE (PSF)
24	101.0
12	168.5

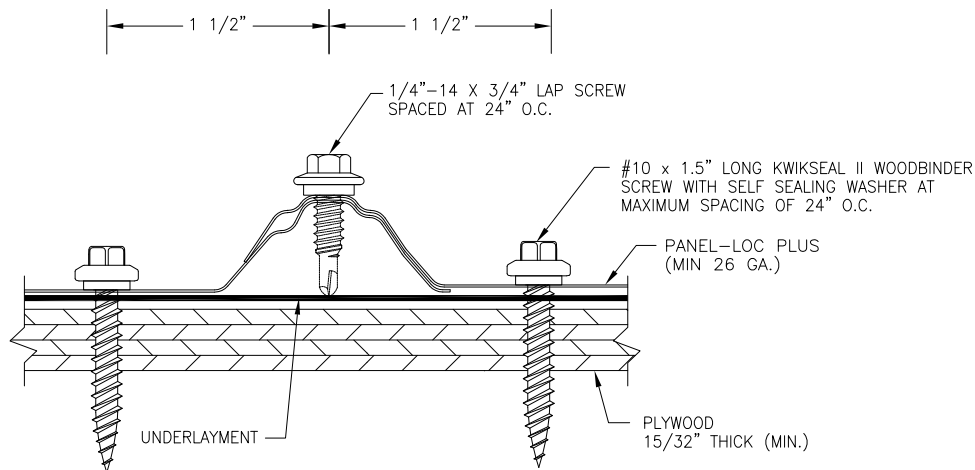

DETAIL 1

#### GENERAL NOTES:

1. ARCHITECTURAL ROOF PANEL HAS BEEN DESIGNED IN ACCORDANCE WITH THE FLORIDA BUILDING CODE (FBC).
2. ROOF PANELS ARE SHALL BE 26 GA. EFFECTIVE COVERING WIDTH OF PANEL = 36".
3. ROOF PANELS SHALL BE INSTALLED OVER SHEATHING & STRUCTURE AS SPECIFIED ON THIS DRAWING.
4. REQUIRED DESIGN WIND LOADS SHALL BE DETERMINED FOR EACH PROJECT. THIS PANEL SYSTEM MAY NOT BE INSTALLED WHEN THE REQUIRED DESIGN WIND LOADS ARE GREATER THAN THE ALLOWABLE WIND LOAD TABLE.
5. ALL FASTENERS MUST BE IN ACCORDANCE WITH THIS DRAWING & THE FLORIDA BUILDING CODE. IF A DIFFERENCE OCCURS BETWEEN THE MINIMUM REQUIREMENTS OF THIS DRAWING & THE CODE, THE CODE SHALL CONTROL.
6. RAFTERS/JOISTS/TRUSSES MUST BE DESIGNED TO WITHSTAND WIND LOADS AS REQUIRED FOR EACH APPLICATION AND ARE THE RESPONSIBILITY OF OTHERS.

DRAWN BY: B.S.	CHECKED BY: A.H.
PLOT:	DATE: 10/21/15
DATE	
BY	
REVISION DESCRIPTION	
NO.	
<b>DRAWING TITLE</b> PANEL-LOC PLUS PANEL	
<b>MANUFACTURER</b> CENTRAL STATES MANUFACTURING, INC. 302 JANE PLACE LOWELL, AR 72745 800-356-2733	
<b>CONSULTANTS</b> BALA SOCKALINGAM, PH.D., P.E. 1216 N LANSING AVE. SUITE C TULSA, OK 74106 PHONE: 918-492-5992 FAX: 866-366-1543	
DRAWING NO. <b>2399-3</b>	REV.
PAGE NO. <b>1</b>	OF <b>1</b>