

# BMP INTERNATIONAL, INC.

## MECHANICAL UNIT STEEL TIE-DOWN CLIP: AT GRADE & ROOF-TOP MOUNTED APPLICATIONS

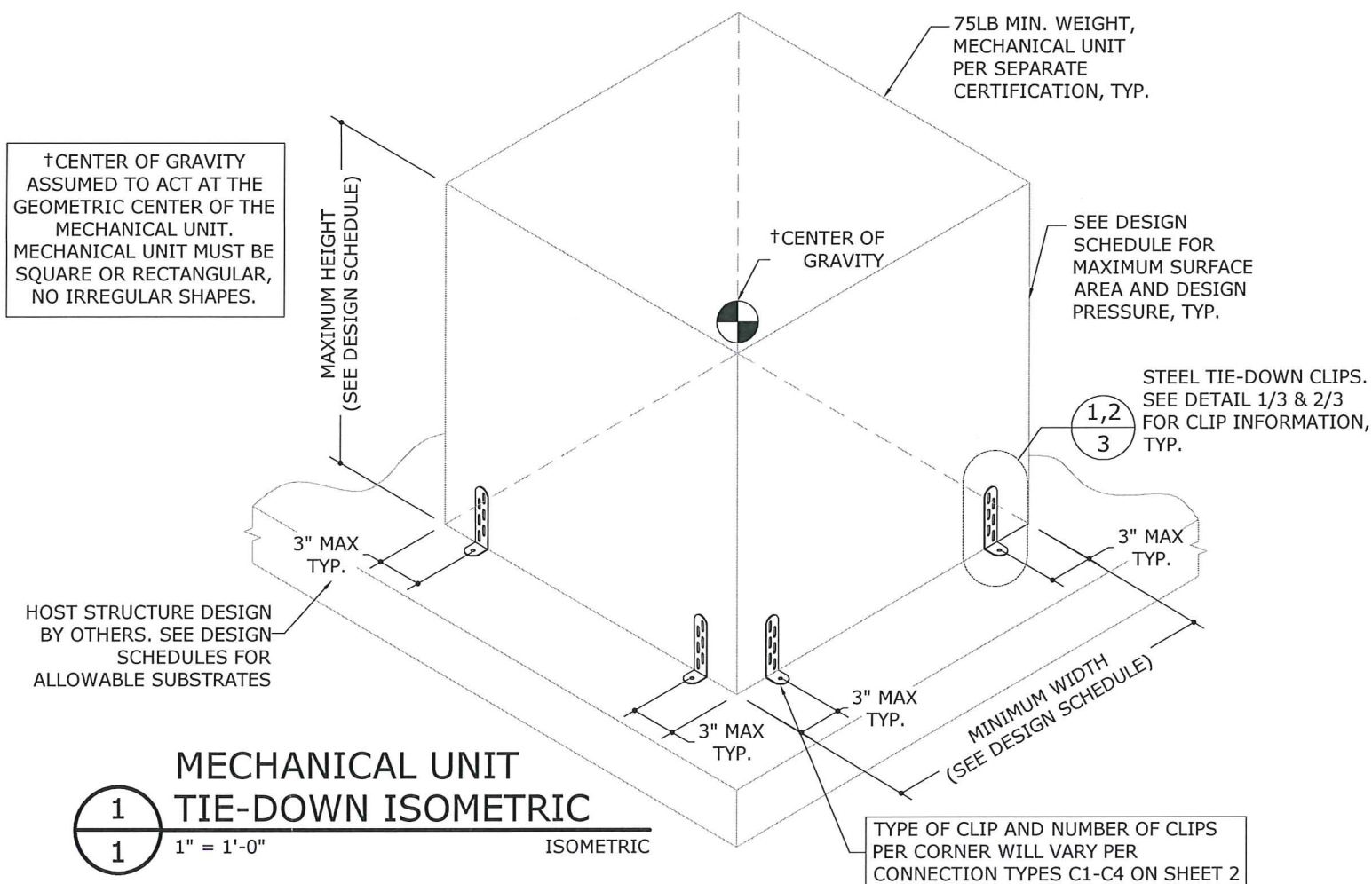

### TIE-DOWN CLIP DIRECTIVE EXAMPLE

(THE FOLLOWING EXAMPLE ILLUSTRATES THE PROCEDURE USED TO DETERMINE THE MAXIMUM ALLOWABLE ROOF-TOP INSTALLATION HEIGHT, H, FOR ANY GIVEN MECHANICAL UNIT THAT CONFORMS TO THE DIMENSION RESTRICTIONS AND DESIGN CRITERIA LISTED HEREIN. SEE SHEETS 4-5 FOR DESIGN SCHEDULES.)

#### MECHANICAL UNIT CRITERIA:

CONSIDER THE INSTALLATION OF (1) MECHANICAL UNIT WITH THE FOLLOWING CRITERIA=

- Vult=170 MPH, EXPOSURE 'B'
- 48" TALL x 48" DEEP x 48" WIDE, 100 LB (WEIGHT AS VERIFIED BY OTHERS)
- INSTALLED TO 3000 PSI MIN CONCRETE WITH (1)-2" CLIP AT EACH CORNER OF UNIT (TOTAL OF (4) CLIPS)

#### PROCEDURE:

PROCEDURE STEP	RESULT
1 DETERMINE THE CONNECTION TYPE BASED ON THE DIAGRAMS ON SHEET 2	CONNECTION TYPE 3
2 DETERMINE WHICH DESIGN SCHEDULE TABLE TO USE	THIS INSTALLATION IS INTENDED FOR A Vult=170 MPH, EXPOSURE 'B'. THIS DESIGN CRITERIA CORRESPONDS TO TABLE 5
3 DETERMINE LARGEST FACE AREA OF MECHANICAL UNIT TO BE INSTALLED	48"x48"=16FT <sup>2</sup>
4 CHECK MAXIMUM UNIT HEIGHT RESTRICTION	THIS UNIT HEIGHT OF 48" IS EQUAL TO THE MAXIMUM ALLOWABLE HEIGHT OF 48". <b>NOTE: THIS PRODUCT APPROVAL ALLOWS THE UNIT TO BE INSTALLED ON TOP OF AN A/C STAND THAT IS A MAXIMUM 30" TALL. IF AN A/C STAND IS UTILIZED, CHECK TO SEE THAT THE STAND DOES NOT EXCEED 30" IN HEIGHT</b>
5 CHECK MINIMUM UNIT WIDTH RESTRICTION	UNIT WIDTH IS 48" WHICH IS GREATER THAN THE MINIMUM ALLOWABLE WIDTH OF 24"
6 DETERMINE THE ALLOWABLE ROOF-TOP HEIGHT OF THE INSTALLATION	THIS UNIT MAY BE INSTALLED AT ROOF HEIGHTS LESS THAN OR EQUAL TO 15 FT. ADDITIONALLY, THIS UNIT MAY BE INSTALLED ON ROOF-TOP HEIGHTS GREATER THAN 60FT AND LESS THAN 100 FT. SEE (*) ON TABLE 5 FOR THE NUMERICAL VALUES OF THIS DESIGN EXAMPLE

### DESIGN NOTES:

THIS PRODUCT HAS BEEN DESIGNED IN ACCORDANCE WITH ASCE 7-10 AND THE FLORIDA BUILDING CODE FOR USE WITHIN AND OUTSIDE THE HIGH VELOCITY HURRICANE ZONES AS INDICATED IN THE ACCOMPANYING DESIGN SCHEDULES. THE DESIGN CRITERIA USED TO CALCULATE THE ALLOWABLE ROOF-TOP HEIGHTS CONSIDERS ASCE 7-10 SECTION 29.5.1 FOR ROOF TOP HEIGHTS (H) ≤60 FT AND SECTION 29.5 FOR ROOF TOP HEIGHTS (H)>60 FT & SECTION 29.4.1 FOR INSTALLATIONS AT GRADE.  $(GC_f)_{lateral}=3.10$  WITHIN THE HVHZ,  $(GC_f)_{lateral}=1.90$  OUTSIDE THE HVHZ,  $(GC_f)_{uplift}=1.5$  FOR ALL LOCATIONS (CONCURRENT). ALL OTHER DESIGN VARIABLES ARE IN ACCORDANCE WITH ASCE 7-10 CHAPTERS 26 & 29. THE HEIGHTS LISTED IN THE DESIGN SCHEDULES REPRESENT THE ALLOWABLE HEIGHT OF THE BUILDING. THIS PRODUCT APPROVAL ALLOWS FOR EACH UNIT TO BE INSTALLED ON A MAXIMUM 30" TALL A/C STAND (CERTIFICATION BY OTHERS) ON TOP OF THE HEIGHTS LISTED IN THE DESIGN SCHEDULES.

### GENERAL NOTES:

- THIS PRODUCT HAS BEEN DESIGNED AND SHALL BE FABRICATED IN ACCORDANCE WITH THE REQUIREMENTS OF THE FLORIDA BUILDING CODE & ASCE 7-10. THIS PRODUCT MAY BE USED WITHIN AND OUTSIDE THE HIGH VELOCITY HURRICANE ZONE.
- NO 33-1/3% INCREASE IN ALLOWABLE STRESS HAS BEEN USED IN THE DESIGN OF THIS SYSTEM.
- DESIGN IS BASED ON CLIENT PROVIDED PRODUCT AND DIE SHEETS FROM TEST REPORTS #TEL 01970387A, #TEL 01970387B BY TESTING EVALUATION LABORATORIES, INC.. NO SUBSTITUTIONS WITHOUT WRITTEN APPROVAL BY THIS ENGINEER SHALL BE PERMITTED.
- MAXIMUM & MINIMUM DIMENSIONS AND MINIMUM WEIGHT OF MECHANICAL UNIT SHALL CONFORM TO SPECIFICATIONS STATED HEREIN. ALL MECHANICAL SPECIFICATIONS (CLEAR SPACE, TONNAGE, ETC.) SHALL BE AS PER MANUFACTURER RECOMMENDATIONS AND ARE THE EXPRESS RESPONSIBILITY OF THE CONTRACTOR.
- FASTENERS TO BE #12 X 3/4" OR GREATER SAE GRADE 5 UNLESS NOTED OTHERWISE. TAPCONS REFERRED TO HEREIN SHALL BE ITW BUILDEX BRAND, CARBON STEEL ONLY, INSTALLED TO 3000 PSI MIN CONCRETE. SEE ANCHOR SCHEDULE FOR ANCHOR REQUIREMENTS. ALL FASTENERS SHALL HAVE APPROPRIATE CORROSION PROTECTION TO PREVENT ELECTROLYSIS.
- ALL STEEL CLIPS SHALL BE ASTM A283 STEEL (GRADE D) WITH  $F_y=33$  KSI OR BETTER. ALL STEEL MEMBERS SHALL BE PROTECTED AGAINST CORROSION WITH AN APPROVED COAT OF PAINT, ENAMEL OR OTHER APPROVED PROTECTION. G90-RATED COATING REQUIRED FOR ALL COASTAL INSTALLATIONS.
- ALL CONCRETE SPECIFIED HEREIN IS NOT PART OF THIS CERTIFICATION. AS A MINIMUM, ALL CONCRETE SHALL BE STRUCTURAL CONCRETE 4" MIN. THICK AND SHALL HAVE MINIMUM COMPRESSIVE STRENGTH OF 3000 PSI, UNLESS NOTED OTHERWISE.
- THE CONTRACTOR IS RESPONSIBLE TO INSULATE ALL MEMBERS FROM DISSIMILAR MATERIALS TO PREVENT ELECTROLYSIS.
- ELECTRICAL GROUND, WHEN REQUIRED, TO BE DESIGNED & INSTALLED BY OTHERS.
- THE ADEQUACY OF ANY EXISTING STRUCTURE TO WITHSTAND SUPERIMPOSED LOADS SHALL BE VERIFIED BY THE ONSITE DESIGN PROFESSIONAL AND IS NOT INCLUDED IN THIS CERTIFICATION. EXCEPT AS EXPRESSLY PROVIDED HEREIN, NO ADDITIONAL CERTIFICATIONS OR AFFIRMATIONS ARE INTENDED.
- THE SYSTEM DETAILED HEREIN IS GENERIC AND DOES NOT PROVIDE INFORMATION FOR A SPECIFIC SITE. FOR SITE CONDITIONS DIFFERENT FROM THE CONDITIONS DETAILED HEREIN, A LICENSED ENGINEER OR REGISTERED ARCHITECT SHALL PREPARE SITE SPECIFIC DOCUMENTS FOR USE IN CONJUNCTION WITH THIS DOCUMENT.
- WATER-TIGHTNESS OF EXISTING HOST SUBSTRATE SHALL BE THE FULL RESPONSIBILITY OF THE INSTALLING CONTRACTOR. CONTRACTOR SHALL ENSURE THAT ANY REMOVED OR ALTERED WATERPROOFING MEMBRANE IS RESTORED AFTER FABRICATION AND INSTALLATION OF STRUCTURE PROPOSED HEREIN. THIS ENGINEER SHALL NOT BE RESPONSIBLE FOR ANY WATERPROOFING OR LEAKAGE ISSUES WHICH MAY OCCUR AS WATER-TIGHTNESS SHALL BE THE FULL RESPONSIBILITY OF THE INSTALLING CONTRACTOR.
- FOR AN EXPLANATION OF EXPOSURE CATEGORIES THAT ACCOMPANY THE Vult WIND SPEEDS USED IN THIS APPROVAL, SEE SECTION 26.7.3 OF ASCE 7-10.

FRANK L. BENNARDO, P.E.  
#PE0046549

FRANK L. BENNARDO  
LICENSE # 04-17-12-000

ENGINEERING EXPRESS  
160 SW 12th AVE, SUITE #106  
DEERFIELD BEACH, FL 33442  
PH: (954) 354-0660 FAX: (954) 354-0443  
WWW.ENGINEERINGEXPRESS.COM

CERT. OF AUTH. #9898  
A FRANK L. BENNARDO, P.E., INC. ENGINEER

**BMP INTERNATIONAL, INC.**  
4710 28TH STREET NORTH  
ST. PETERSBURG, FL 33471  
PH: (727) 577-1613

MECHANICAL UNIT STEEL TIE-DOWN CLIPS

FBC 5TH EDITION (2014) PRODUCT APPROVAL FL# 14239.1

REMARKS	DRWN	CHKD	DATE
INIT ISSUE (11-BMP-0001)	FLB	FLB	12-11-11
REV FOR UNITS	CSL	TSB	02-15-13
REV FOR FBC 5TH (2014)	RWN	CSL	04-06-15

THIS DOCUMENT IS THE PROPERTY OF FRANK L. BENNARDO, P.E. AND SHALL NOT BE REPRODUCED OR TRANSMITTED IN ANY FORM OR BY ANY MEANS, ELECTRONIC OR MECHANICAL, INCLUDING PHOTOCOPYING, RECORDING, OR BY ANY INFORMATION STORAGE AND RETRIEVAL SYSTEM. WITHOUT THE WRITTEN PERMISSION OF FRANK L. BENNARDO, P.E., NO PART OF THIS DOCUMENT IS TO BE REPRODUCED OR TRANSMITTED IN ANY FORM OR BY ANY MEANS, ELECTRONIC OR MECHANICAL, INCLUDING PHOTOCOPYING, RECORDING, OR BY ANY INFORMATION STORAGE AND RETRIEVAL SYSTEM. WITHOUT THE WRITTEN PERMISSION OF FRANK L. BENNARDO, P.E., NO PART OF THIS DOCUMENT IS TO BE REPRODUCED OR TRANSMITTED IN ANY FORM OR BY ANY MEANS, ELECTRONIC OR MECHANICAL, INCLUDING PHOTOCOPYING, RECORDING, OR BY ANY INFORMATION STORAGE AND RETRIEVAL SYSTEM.

COPYRIGHT FRANK L. BENNARDO P.E.

15-2378

SCALE: N.T.S.

PAGE DESCRIPTION:

1

5

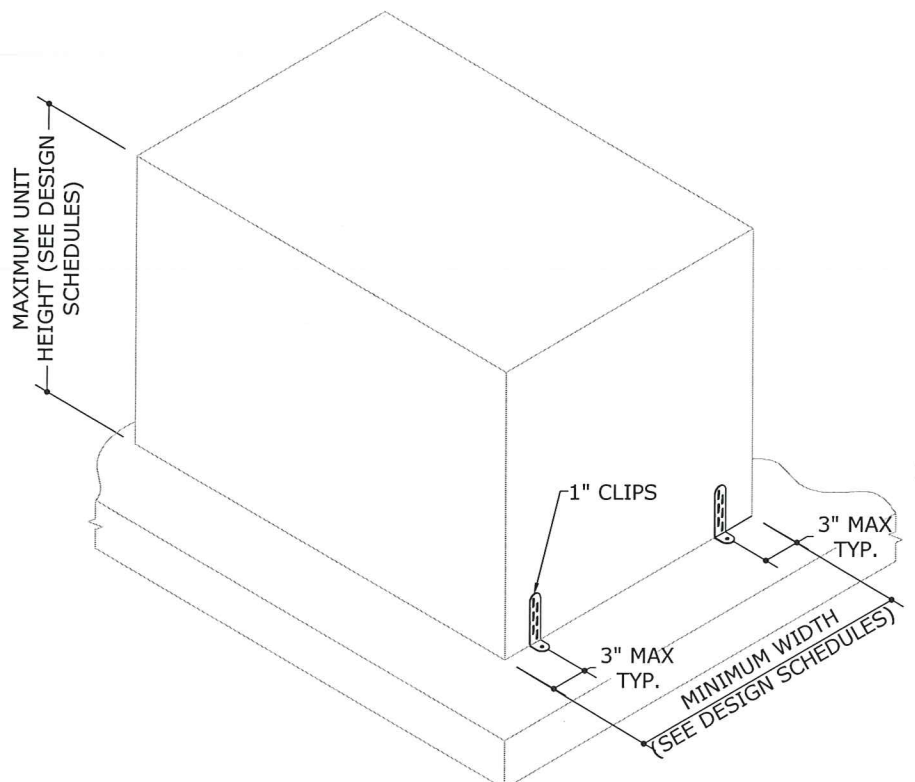

**C1 CONNECTION TYPE C1**  
 1" CLIP - UTILIZE (1) AT EACH CORNER FOR A TOTAL OF (4) PER UNIT

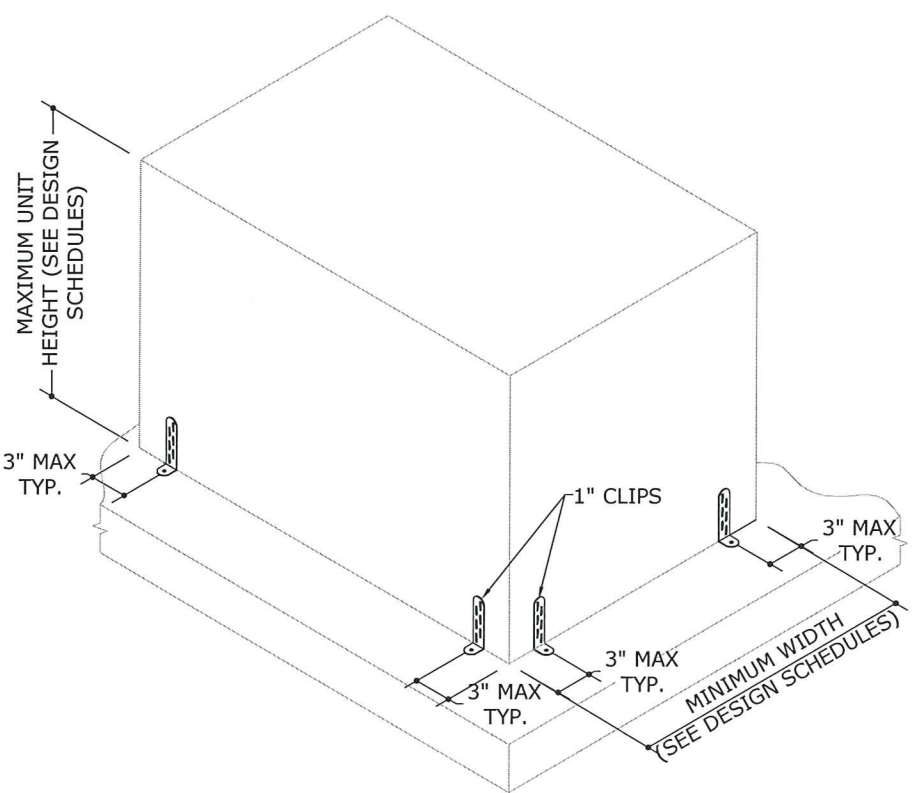

**C2 CONNECTION TYPE C2**  
 1" CLIP - UTILIZE (2) AT EACH CORNER FOR A TOTAL OF (8) PER UNIT

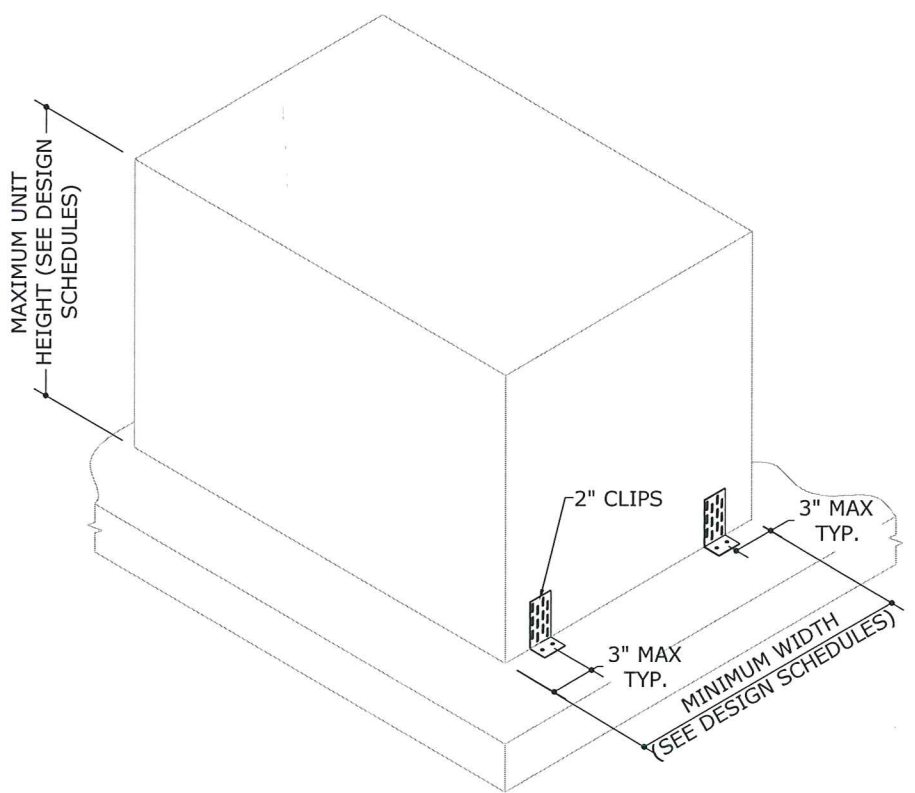

**C3 CONNECTION TYPE C3**  
 2" CLIPS - UTILIZE (1) AT EACH CORNER FOR A TOTAL OF (4) PER UNIT

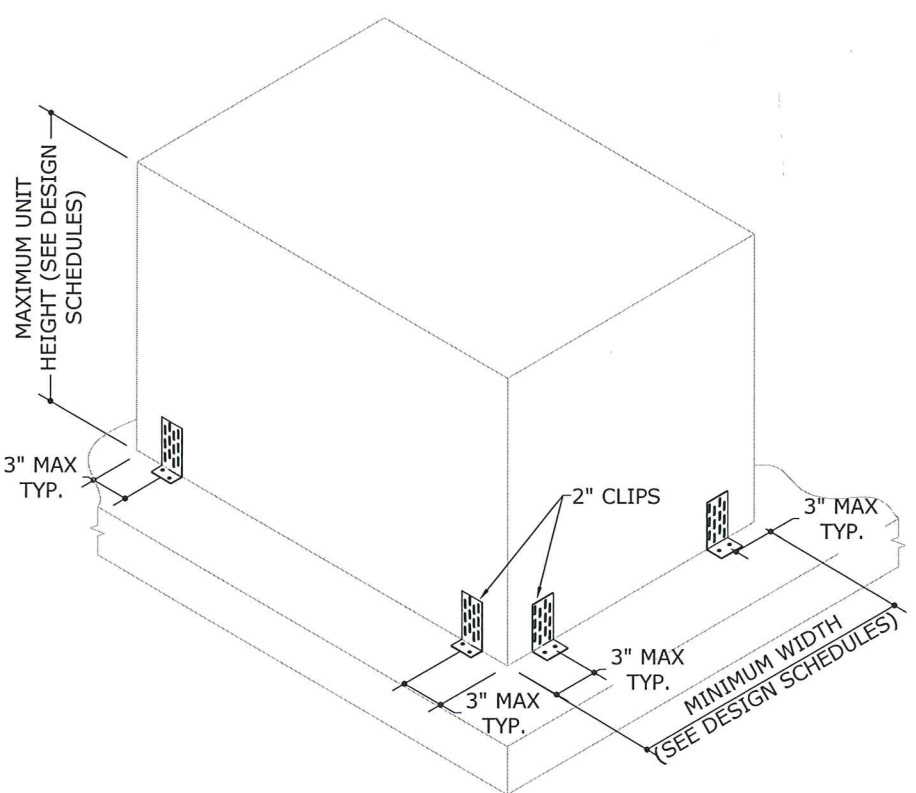

**C4 CONNECTION TYPE C4**  
 2" CLIPS - UTILIZE (2) AT EACH CORNER FOR A TOTAL OF (8) PER UNIT

**ANCHOR SCHEDULE:  
 1" CLIPS**

SUBSTRATE	DESCRIPTION
CONCRETE: (4" THICK MIN, 3000 PSI MIN.)	(1)-5/16"Ø CARBON STEEL ITW BUILDDEX TAPCON, 2¼" FULL EMBED TO CONCRETE, 3⅝" MIN. EDGE DISTANCE, 3¾" MIN. SPACING TO ANY ADJACENT ANCHOR.
ALUMINUM: (0.125" MIN. THICK, 6061-T6 MIN. ALUMINUM)	(1)-#14 SAE GRADE 5 SHEET METAL SCREW TO ALUMINUM, PROVIDE (5) PITCHES MIN. PAST THREAD PLANE
STEEL: (0.125" MIN. THICK, 33 KSI MIN. STEEL)	(1)-#14 SAE GRADE 5 SHEET METAL SCREW TO STEEL, PROVIDE (5) PITCHES MIN. PAST THREAD PLANE

**2" CLIPS**

SUBSTRATE	DESCRIPTION
CONCRETE: (4" THICK MIN, 3000 PSI MIN.)	(1)-5/16"Ø CARBON STEEL ITW BUILDDEX TAPCON, 2¼" FULL EMBED TO CONCRETE, 3⅝" MIN. EDGE DISTANCE, 3¾" MIN. SPACING TO ANY ADJACENT ANCHOR.
ALUMINUM: (0.125" MIN. THICK, 6061-T6 MIN. ALUMINUM)	(2)-#14 SAE GRADE 5 SHEET METAL SCREWS TO ALUMINUM, PROVIDE (5) PITCHES MIN. PAST THREAD PLANE
STEEL: (0.125" MIN. THICK, 33 KSI MIN. STEEL)	(2)-#14 SAE GRADE 5 SHEET METAL SCREWS TO STEEL, PROVIDE (5) PITCHES MIN. PAST THREAD PLANE

1. EMBEDMENT AND EDGE DISTANCE EXCLUDES FINISHES, IF APPLICABLE.
2. ENSURE MINIMUM EDGE DISTANCE AS NOTED IN ANCHOR SCHEDULE.
3. SEE DETAILS ON SHEET 3 FOR ANCHORS ATTACHING TO MECHANICAL UNIT.

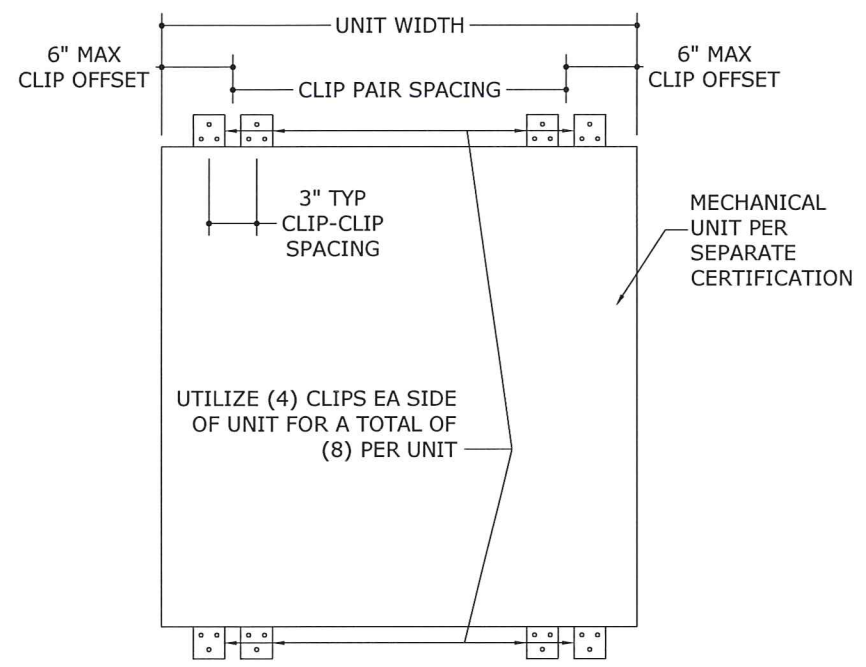

**5 ALTERNATE (8) CLIP DETAIL**  
 3 N.T.S. PLAN VIEW

THIS DETAIL MAY BE USED AS AN ALTERNATE GEOMETRIC PATTERN FOR ALL CONNECTION TYPES THAT UTILIZE (2) CLIPS AT EACH CORNER FOR A TOTAL OF (8) CLIPS PER UNIT.

FRANK L. BENNARDO, P.E.  
 # 041152015  
 FRANK L. BENNARDO  
 041152015  
 No. 46549  
 ENGINEERING EXPRESS  
 160 SW 12th AVENUE, #1115  
 DEERFIELD BEACH, FL 33442  
 PH: (954) 354-0660 FAX: (954) 354-0488  
 WWW.ENGINEERINGEXPRESS.COM  
 CERT. OF AUTH #9857  
 A FRANK L. BENNARDO, P.E., INC. JACKSONVILLE, FL

**BMP INTERNATIONAL, INC.**  
 4710 28TH STREET NORTH  
 ST. PETERSBURG, FL 33471  
 PH: (727) 577-1613  
 MECHANICAL UNIT STEEL TIE-DOWN CLIPS  
 PRODUCT APPROVAL FL#14239.1  
 FBK 5TH EDITION (2014)

REMARKS	DRWN	CHKD	DATE
INIT ISSUE (11-BMP-0001)	TSB	FLB	12-11-11
REV FOR UNITS	CSL	TSB	02-15-13
REV FOR FBK 5TH (2014)	RWN	CSL	04-06-15

THIS DOCUMENT IS THE PROPERTY OF FRANK L. BENNARDO, P.E. AND SHALL NOT BE REPRODUCED IN WHOLE OR PART WITHOUT WRITTEN CONSENT OF FRANK L. BENNARDO, P.E. ANY UNAUTHORIZED REPRODUCTION OR TRANSMISSION OF THIS DOCUMENT ARE NOT PERMITTED AND INVALIDATE OUR CERTIFICATION.

15-2378  
 SCALE: N.T.S.  
 PAGE DESCRIPTION:  
 2 OF 5

04/17/2015 - 3:56pm chen V:\Projects\15-2378 Air Handler Tiedown Clips - FSA - Update FL14239 for 2014 Florida Bldg C-Project\WP15-2378b - Air Handler Tiedown Clips - FSA - Update FL14239 for 2014 Florida Bldg C-Project.dwg

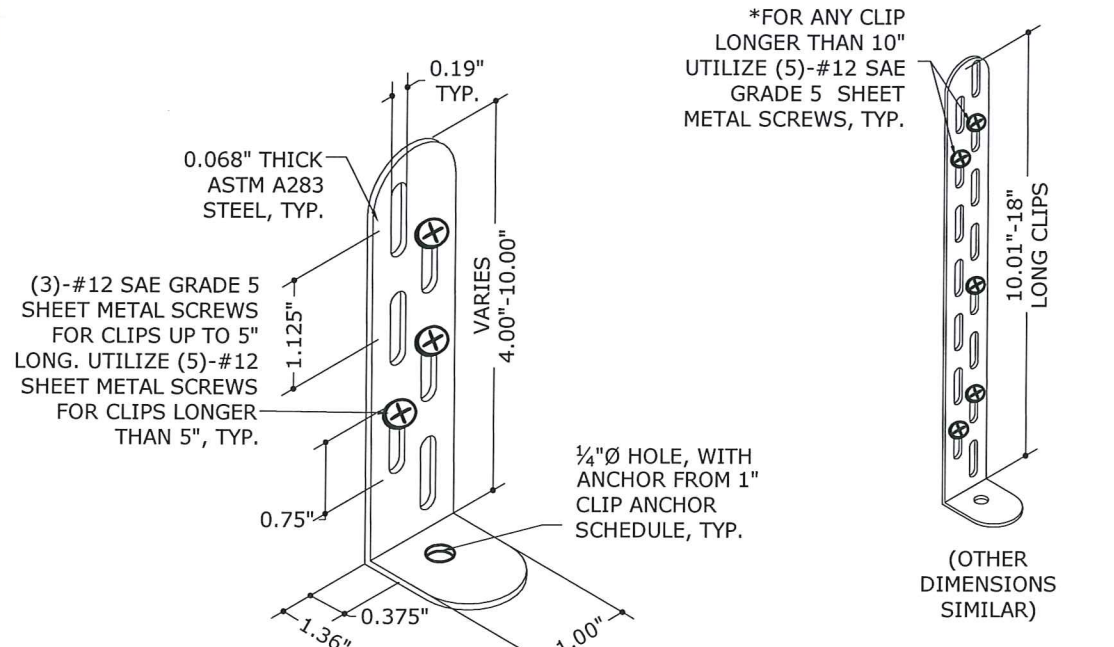

**1 1" CLIP ISOMETRIC DETAIL**  
 3 N.T.S. ISOMETRIC

\*FOR ANY CLIP LONGER THAN 10" UTILIZE (5)-#12 SAE GRADE 5 SHEET METAL SCREWS, TYP.

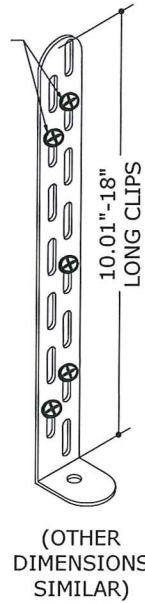

MECHANICAL UNIT BY OTHERS. ALUMINUM HOUSING UNITS SHALL BE 6063-T6 MIN. ALUMINUM SHEET WITH Fty=30 KSI, 0.125" MIN. THICKNESS, STEEL HOUSING UNITS SHALL BE ASTM A653 Fy=33KSI MIN. STEEL, GRADE 33, 22GA MIN. (t=0.0299").

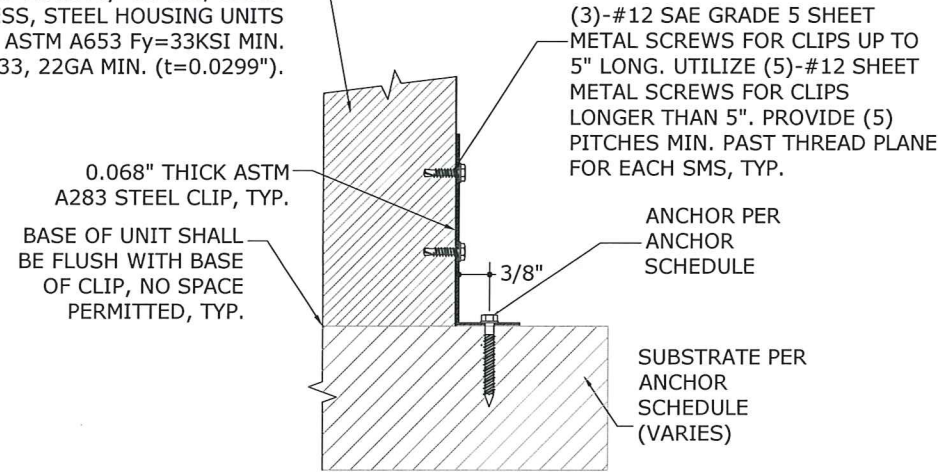

**3 1" TIE-DOWN CLIP ANCHOR DETAIL**  
 3 3" = 1'-0" DETAIL  
 CLIP IS DESIGNED FOR FULL CONTACT WITH THE BASE OF EACH MECHANICAL UNIT, TYP.

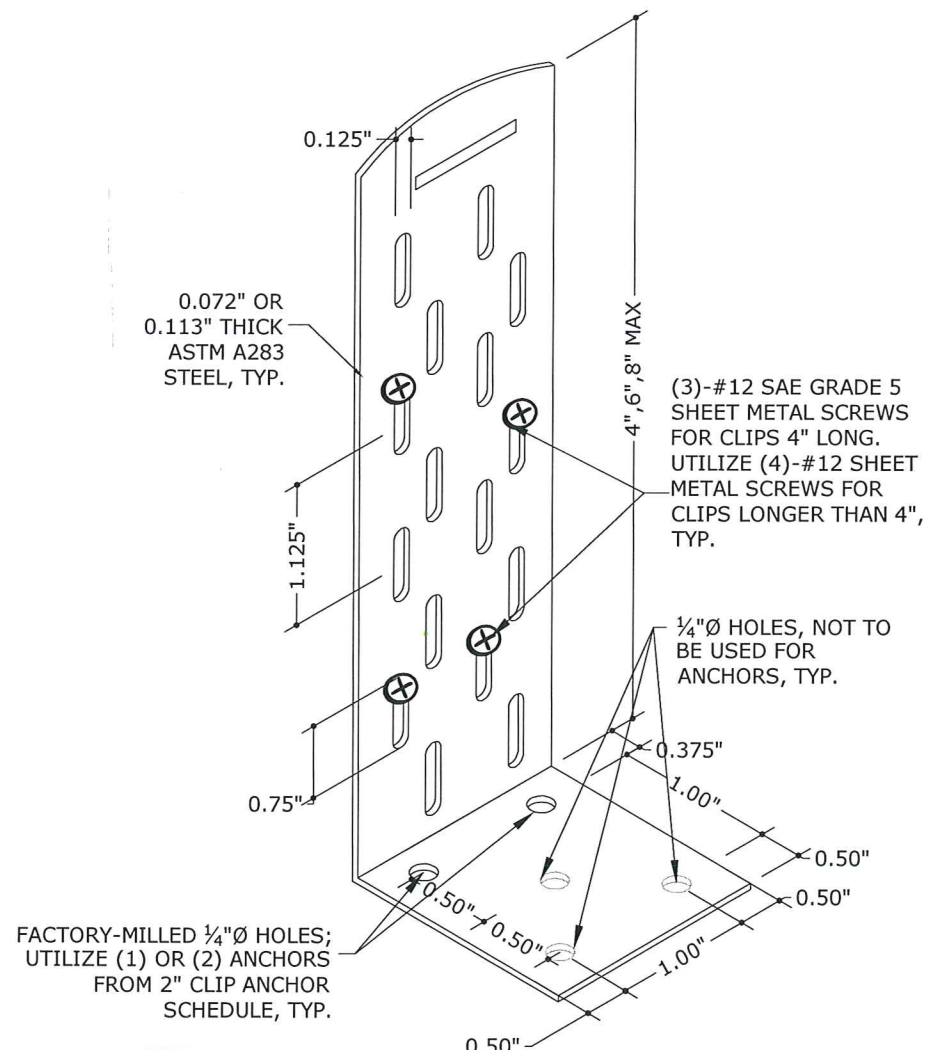

**2 2" CLIP ISOMETRIC DETAIL**  
 3 N.T.S. ISOMETRIC

MECHANICAL UNIT BY OTHERS. ALUMINUM HOUSING UNITS SHALL BE 6063-T6 MIN. ALUMINUM SHEET WITH Fty=30 KSI, 0.125" MIN. THICKNESS, STEEL HOUSING UNITS SHALL BE ASTM A653 Fy=33KSI MIN. STEEL, GRADE 33, 22GA MIN. (t=0.0299").

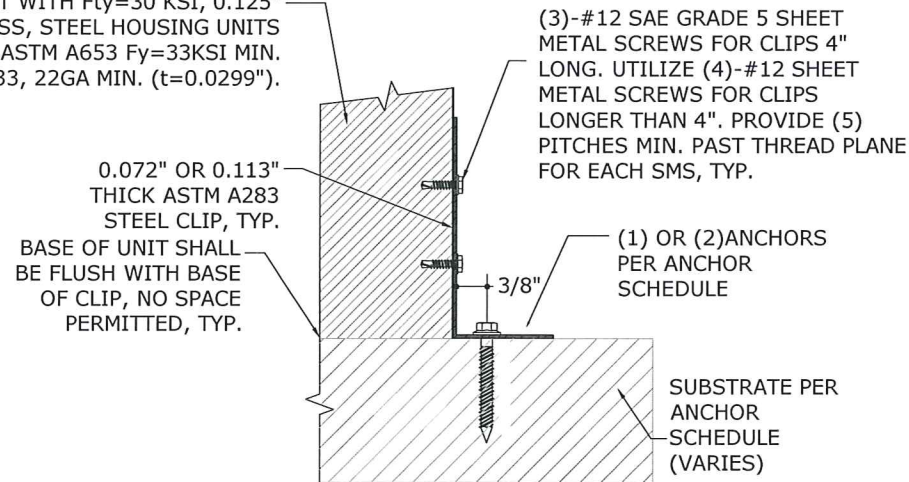

**4 2" TIE-DOWN CLIP ANCHOR DETAIL**  
 3 3" = 1'-0" DETAIL  
 CLIP IS DESIGNED FOR FULL CONTACT WITH THE BASE OF EACH MECHANICAL UNIT, TYP.

FRANK L. BENNARDO, P.E.  
 LICENSE NO. 041437-2010  
 No. 46549  
 ENGINEERING EXPRESS  
 160 SW 12th AVENUE, #106  
 DEERFIELD BEACH, FL 33442  
 PH: (954) 354-0660 FAX: (954) 354-0443  
 WWW.ENGEXP.COM  
 CERT OF AUTH #9885  
 A FRANK L. BENNARDO, P.E., INC. INNOVATION

**BMP INTERNATIONAL, INC.**  
 4710 28TH STREET NORTH  
 ST. PETERSBURG, FL 33471  
 PH: (727) 577-1613  
 MECHANICAL UNIT STEEL TIE-DOWN CLIPS  
 FBC 5TH EDITION (2014) PRODUCT APPROVAL FL#14239.1

REMARKS	DRWN	CHKD	DATE
INIT ISSUE (11-BMP-0001)	TSB	FLB	12-11-11
REV FOR UNITS	CSL	TSB	02-15-13
REV FOR FBC 5TH (2014)	RWN	CSL	04-08-15

THIS DOCUMENT IS THE PROPERTY OF FRANK L. BENNARDO, P.E. AND SHALL NOT BE REPRODUCED IN WHOLE OR PART WITHOUT WRITTEN CONSENT OF FRANK L. BENNARDO, P.E. ALTERATIONS, ADDITIONS, OMISSIONS, OR OTHER MARKINGS TO THIS DOCUMENT ARE NOT PERMITTED AND WILL INVAIDATE OUR CERTIFICATION.

COPYRIGHT FRANK L. BENNARDO P.E.  
 15-2378  
 SCALE: N.T.S.  
 PAGE DESCRIPTION:  
 3 OF 5

**TABLE 1: Vult=175 MPH, EXPOSURE C**

(FOR USE WITH A RISK CATEGORY II STRUCTURE IN THE HIGH VELOCITY HURRICANE ZONE\*)

MAXIMUM SURFACE AREA OF UNIT'S LARGEST FACE	UNIT HEIGHT	UNIT WIDTH	ALLOWABLE ROOF-TOP HEIGHT (H) TIE-DOWN CONFIGURATION TYPE			
			C1	C2	C3	C4
6 FT <sup>2</sup>	24" MAX	12" MIN	N/A	AT GRADE	AT GRADE	H ≤ 200 FT
9 FT <sup>2</sup>	32" MAX	15" MIN	N/A	AT GRADE	AT GRADE	H ≤ 60 FT
4 FT <sup>2</sup>	48" MAX	24" MIN	AT GRADE	H ≤ 200 FT	H ≤ 30 FT	H ≤ 200 FT
6 FT <sup>2</sup>			AT GRADE	H ≤ 40 FT	AT GRADE	H ≤ 200 FT
9 FT <sup>2</sup>			N/A	AT GRADE	AT GRADE	H ≤ 160 FT
12 FT <sup>2</sup>			N/A	AT GRADE	AT GRADE	H ≤ 40 FT
16 FT <sup>2</sup>	60" MAX	48" MIN	N/A	AT GRADE	N/A	AT GRADE
20 FT <sup>2</sup>			N/A	AT GRADE	N/A	AT GRADE
25 FT <sup>2</sup>			N/A	AT GRADE	N/A	AT GRADE
30 FT <sup>2</sup>			N/A	N/A	N/A	AT GRADE
36 FT <sup>2</sup>			N/A	N/A	N/A	AT GRADE

\*THIS TABLE IS PERMISSIBLE TO BE USED WITHIN THE HVHZ WHICH CONTAINS BROWARD AND MIAMI-DADE COUNTIES. CHECK WITH LOCAL AUTHORITY HAVING JURISDICTION FOR THE APPLICABILITY OF THIS TABLE WITHIN CERTAIN FLORIDA COUNTIES.

**TABLE 2 : Vult=175 MPH, EXPOSURE D**

(FOR USE WITH A RISK CATEGORY II STRUCTURE IN THE HIGH VELOCITY HURRICANE ZONE\*)

MAXIMUM SURFACE AREA OF UNIT'S LARGEST FACE	UNIT HEIGHT	UNIT WIDTH	ALLOWABLE ROOF-TOP HEIGHT (H) TIE-DOWN CONFIGURATION TYPE			
			C1	C2	C3	C4
6 FT <sup>2</sup>	24" MAX	12" MIN	N/A	AT GRADE	AT GRADE	H ≤ 200 FT
9 FT <sup>2</sup>	32" MAX	15" MIN	N/A	AT GRADE	N/A	H ≤ 30 FT
4 FT <sup>2</sup>	48" MAX	24" MIN	AT GRADE	H ≤ 200 FT	AT GRADE	H ≤ 200 FT
6 FT <sup>2</sup>			N/A	H ≤ 15 FT	AT GRADE	H ≤ 200 FT
9 FT <sup>2</sup>			N/A	AT GRADE	AT GRADE	H ≤ 80 FT
12 FT <sup>2</sup>			N/A	AT GRADE	N/A	AT GRADE
16 FT <sup>2</sup>	60" MAX	48" MIN	N/A	AT GRADE	N/A	AT GRADE
20 FT <sup>2</sup>			N/A	AT GRADE	N/A	AT GRADE
25 FT <sup>2</sup>			N/A	N/A	N/A	AT GRADE
30 FT <sup>2</sup>			N/A	N/A	N/A	AT GRADE
36 FT <sup>2</sup>			N/A	N/A	N/A	AT GRADE

\*THIS TABLE IS PERMISSIBLE TO BE USED WITHIN THE HVHZ WHICH CONTAINS BROWARD AND MIAMI-DADE COUNTIES. CHECK WITH LOCAL AUTHORITY HAVING JURISDICTION FOR THE APPLICABILITY OF THIS TABLE WITHIN CERTAIN FLORIDA COUNTIES.

**TABLE 3 : Vult=170 MPH, EXPOSURE C**

(FOR USE WITH A RISK CATEGORY II STRUCTURE\*)

MAXIMUM SURFACE AREA OF UNIT'S LARGEST FACE	UNIT HEIGHT	UNIT WIDTH	ALLOWABLE ROOF-TOP HEIGHT (H) TIE-DOWN CONFIGURATION TYPE			
			C1	C2	C3	C4
6 FT <sup>2</sup>	24" MAX	12" MIN	N/A	H ≤ 200 FT	AT GRADE 60 FT < H ≤ 160 FT	H ≤ 200 FT
9 FT <sup>2</sup>	32" MAX	15" MIN	N/A	H ≤ 15 FT 60 FT < H ≤ 200 FT	AT GRADE	H ≤ 200 FT
4 FT <sup>2</sup>	48" MAX	24" MIN	AT GRADE 60 FT < H ≤ 200 FT	H ≤ 200 FT	H ≤ 200 FT	H ≤ 200 FT
6 FT <sup>2</sup>			AT GRADE	H ≤ 200 FT	H ≤ 40 FT 60 FT < H ≤ 200 FT	H ≤ 200 FT
9 FT <sup>2</sup>			N/A	H ≤ 200 FT	AT GRADE 60 FT < H ≤ 80 FT	H ≤ 200 FT
12 FT <sup>2</sup>			N/A	AT GRADE 60 FT < H ≤ 200 FT	N/A	H ≤ 200 FT
16 FT <sup>2</sup>	60" MAX	48" MIN	N/A	AT GRADE	N/A	H ≤ 200 FT
20 FT <sup>2</sup>			N/A	AT GRADE	N/A	H ≤ 200 FT
25 FT <sup>2</sup>			N/A	N/A	N/A	H ≤ 30 FT 60 FT < H ≤ 200 FT
30 FT <sup>2</sup>			N/A	N/A	N/A	AT GRADE 60 FT < H ≤ 180 FT
36 FT <sup>2</sup>			N/A	N/A	N/A	AT GRADE

\*AS AN EXAMPLE, THIS TABLE IS PERMISSIBLE TO BE USED WITHIN PALM BEACH COUNTY. CHECK WITH LOCAL AUTHORITY HAVING JURISDICTION FOR THE APPLICABILITY OF THIS TABLE WITHIN CERTAIN FLORIDA COUNTIES.

**TABLE 4 : Vult=170 MPH, EXPOSURE D**

(FOR USE WITH A RISK CATEGORY II STRUCTURE\*)

MAXIMUM SURFACE AREA OF UNIT'S LARGEST FACE	UNIT HEIGHT	UNIT WIDTH	ALLOWABLE ROOF-TOP HEIGHT (H) TIE-DOWN CONFIGURATION TYPE			
			C1	C2	C3	C4
6 FT <sup>2</sup>	24" MAX	12" MIN	N/A	H ≤ 200 FT	AT GRADE 60 FT < H ≤ 80 FT	H ≤ 200 FT
9 FT <sup>2</sup>	32" MAX	15" MIN	N/A	AT GRADE 60 FT < H ≤ 200 FT	N/A	H ≤ 200 FT
4 FT <sup>2</sup>	48" MAX	24" MIN	AT GRADE 60 FT < H ≤ 100 FT	H ≤ 200 FT	H ≤ 200 FT	H ≤ 200 FT
6 FT <sup>2</sup>			N/A	H ≤ 200 FT	H ≤ 15 FT 60 FT < H ≤ 200 FT	H ≤ 200 FT
9 FT <sup>2</sup>			N/A	H ≤ 15 FT 60 FT < H ≤ 200 FT	AT GRADE	H ≤ 200 FT
12 FT <sup>2</sup>			N/A	AT GRADE 60 FT < H ≤ 120 FT	N/A	H ≤ 200 FT
16 FT <sup>2</sup>	60" MAX	48" MIN	N/A	N/A	N/A	H ≤ 40 FT 60 FT < H ≤ 200 FT
20 FT <sup>2</sup>			N/A	AT GRADE	N/A	H ≤ 40 FT 60 FT < H ≤ 200 FT
25 FT <sup>2</sup>			N/A	N/A	N/A	AT GRADE 60 FT < H ≤ 200 FT
30 FT <sup>2</sup>			N/A	N/A	N/A	AT GRADE 60 FT < H ≤ 100 FT
36 FT <sup>2</sup>			N/A	N/A	N/A	AT GRADE

\*AS AN EXAMPLE, THIS TABLE IS PERMISSIBLE TO BE USED WITHIN PALM BEACH COUNTY. CHECK WITH LOCAL AUTHORITY HAVING JURISDICTION FOR THE APPLICABILITY OF THIS TABLE WITHIN CERTAIN FLORIDA COUNTIES.

FRANK L. BENNARDO, P.E.  
 No. 46549  
 ENGINEERING EXPRESS  
 160 SW 12th AVENUE, #1186  
 DEERFIELD BEACH, FL 33442  
 PH: (954) 354-0660 FAX: (954) 354-0443  
 WWW.ENGINEERINGEXPRESS.COM  
 CERT. OF AUTH. #9885  
 A FRANK L. BENNARDO, P.E., INC. INNOVATION

**BMP INTERNATIONAL, INC.**

4710 28TH STREET NORTH  
 ST. PETERSBURG, FL 33471  
 PH: (727) 577-1613

MECHANICAL UNIT STEEL TIE-DOWN CLIPS

FBC 5TH EDITION (2014) PRODUCT APPROVAL FL#14239.1

REMARKS	DRWN	CHKD	DATE
INIT ISSUE (11-BMP-0001)	TSB	FLB	12-11-11
REV FOR UNITS	CSL	TSB	02-15-13
REV FOR FBC 5TH (2014)	RWN	CSL	04-06-15

THIS DOCUMENT IS THE PROPERTY OF FRANK L. BENNARDO, P.E. AND SHALL NOT BE REPRODUCED IN WHOLE OR PART WITHOUT WRITTEN CONSENT OF FRANK L. BENNARDO, P.E. ANY UNAUTHORIZED REPRODUCTION OR DISTRIBUTION OF THIS DOCUMENT IS STRICTLY PROHIBITED AND WILL BE PURSUED TO THE FULL EXTENT OF THE LAW.

COPYRIGHT FRANK L. BENNARDO P.E.

15-2378

SCALE: N.T.S.

PAGE DESCRIPTION:

04/17/2015 - 3:56pm chen V:\Projects\15-2378 Air Handler Tiedown Clips - FSA - Update FL14239 for 2014 Florida Bldg C-Project\WP15-2378b - Air Handler Tiedown Clips - FSA - Update FL14239 for 2014 Florida Bldg C-Project.dwg

**TABLE 5 : Vult=140 MPH, EXPOSURE B**

(FOR USE WITH A RISK CATEGORY II STRUCTURE\*)

MAXIMUM SURFACE AREA OF UNIT'S LARGEST FACE	UNIT HEIGHT	UNIT WIDTH	ALLOWABLE ROOF-TOP HEIGHT (H) TIE-DOWN CONFIGURATION TYPE			
			C1	C2	C3	C4
6 FT <sup>2</sup>	24" MAX	12" MIN	H ≤ 15 FT 60 FT < H ≤ 120 FT	H ≤ 200 FT	H ≤ 200 FT	H ≤ 200 FT
9 FT <sup>2</sup>	32" MAX	15" MIN	AT GRADE	H ≤ 200 FT	H ≤ 200 FT	H ≤ 200 FT
4 FT <sup>2</sup>	48" MAX	24" MIN	H ≤ 200 FT	H ≤ 200 FT	H ≤ 200 FT	H ≤ 200 FT
6 FT <sup>2</sup>			H ≤ 40 FT 60 FT < H ≤ 200 FT	H ≤ 200 FT	H ≤ 200 FT	H ≤ 200 FT
9 FT <sup>2</sup>			AT GRADE 60 FT < H ≤ 80 FT	H ≤ 200 FT	H ≤ 200 FT	H ≤ 200 FT
12 FT <sup>2</sup>			AT GRADE	H ≤ 200 FT	H ≤ 40 FT 60 FT < H ≤ 200 FT	H ≤ 200 FT
16 FT <sup>2</sup>			N/A	H ≤ 200 FT	H ≤ 15 FT 60 FT < H ≤ 100 FT	H ≤ 200 FT
20 FT <sup>2</sup>	60" MAX	48" MIN	N/A	H ≤ 200 FT	H ≤ 15 FT 60 FT < H ≤ 180 FT	H ≤ 200 FT
25 FT <sup>2</sup>			N/A	H ≤ 40 FT 60 FT < H ≤ 200 FT	AT GRADE 60 FT < H ≤ 80 FT	H ≤ 200 FT
30 FT <sup>2</sup>			N/A	H ≤ 15 FT 60 FT < H ≤ 160 FT	AT GRADE	H ≤ 200 FT
36 FT <sup>2</sup>			N/A	AT GRADE 60 FT < H ≤ 80 FT	AT GRADE	H ≤ 200 FT

\*

**TABLE 6 : Vult=140 MPH, EXPOSURE C**

(FOR USE WITH A RISK CATEGORY II STRUCTURE\*)

MAXIMUM SURFACE AREA OF UNIT'S LARGEST FACE	UNIT HEIGHT	UNIT WIDTH	ALLOWABLE ROOF-TOP HEIGHT (H) TIE-DOWN CONFIGURATION TYPE			
			C1	C2	C3	C4
6 FT <sup>2</sup>	24" MAX	12" MIN	AT GRADE	H ≤ 200 FT	H ≤ 200 FT	H ≤ 200 FT
9 FT <sup>2</sup>	32" MAX	15" MIN	N/A	H ≤ 200 FT	H ≤ 15 FT 60 FT < H ≤ 200 FT	H ≤ 200 FT
4 FT <sup>2</sup>	48" MAX	24" MIN	H ≤ 200 FT	H ≤ 200 FT	H ≤ 200 FT	H ≤ 200 FT
6 FT <sup>2</sup>			AT GRADE 60 FT < H ≤ 180 FT	H ≤ 200 FT	H ≤ 200 FT	H ≤ 200 FT
9 FT <sup>2</sup>			AT GRADE	H ≤ 200 FT	H ≤ 40 FT 60 FT < H ≤ 200 FT	H ≤ 200 FT
12 FT <sup>2</sup>			N/A	H ≤ 200 FT	AT GRADE 60 FT < H ≤ 140 FT	H ≤ 200 FT
16 FT <sup>2</sup>			N/A	H ≤ 15 FT 60 FT < H ≤ 200 FT	AT GRADE	H ≤ 200 FT
20 FT <sup>2</sup>	60" MAX	48" MIN	N/A	H ≤ 30 FT 60 FT < H ≤ 200 FT	AT GRADE	H ≤ 200 FT
25 FT <sup>2</sup>			N/A	AT GRADE 60 FT < H ≤ 140 FT	AT GRADE	H ≤ 200 FT
30 FT <sup>2</sup>			N/A	AT GRADE	N/A	H ≤ 200 FT
36 FT <sup>2</sup>			N/A	AT GRADE	N/A	H ≤ 30 FT 60 FT < H ≤ 200 FT

**TABLE 7 : Vult=140 MPH, EXPOSURE D**

(FOR USE WITH A RISK CATEGORY II STRUCTURE\*)

MAXIMUM SURFACE AREA OF UNIT'S LARGEST FACE	UNIT HEIGHT	UNIT WIDTH	ALLOWABLE ROOF-TOP HEIGHT (H) TIE-DOWN CONFIGURATION TYPE			
			C1	C2	C3	C4
6 FT <sup>2</sup>	24" MAX	12" MIN	N/A	H ≤ 200 FT	H ≤ 30 FT 60 FT < H ≤ 200 FT	H ≤ 200 FT
9 FT <sup>2</sup>	32" MAX	15" MIN	N/A	H ≤ 200 FT	AT GRADE 60 FT < H ≤ 140 FT	H ≤ 200 FT
4 FT <sup>2</sup>	48" MAX	24" MIN	H ≤ 40 FT 60 FT < H ≤ 200 FT	H ≤ 200 FT	H ≤ 200 FT	H ≤ 200 FT
6 FT <sup>2</sup>			AT GRADE 60 FT < H ≤ 100 FT	H ≤ 200 FT	H ≤ 200 FT	H ≤ 200 FT
9 FT <sup>2</sup>			N/A	H ≤ 200 FT	H ≤ 15 FT 60 FT < H ≤ 200 FT	H ≤ 200 FT
12 FT <sup>2</sup>			N/A	H ≤ 40 FT 60 FT < H ≤ 200 FT	AT GRADE 60 FT < H ≤ 80 FT	H ≤ 200 FT
16 FT <sup>2</sup>			N/A	AT GRADE 60 FT < H ≤ 200 FT	N/A	H ≤ 200 FT
20 FT <sup>2</sup>	60" MAX	48" MIN	N/A	AT GRADE 60 FT < H ≤ 200 FT	AT GRADE	H ≤ 200 FT
25 FT <sup>2</sup>			N/A	AT GRADE 60 FT < H ≤ 80 FT	N/A	H ≤ 200 FT
30 FT <sup>2</sup>			N/A	N/A	N/A	H ≤ 40 FT 60 FT < H ≤ 200 FT
36 FT <sup>2</sup>			N/A	N/A	N/A	AT GRADE 60 FT < H ≤ 200 FT

\*AS AN EXAMPLE, THESE TABLES ARE PERMISSIBLE TO BE USED WITHIN BREVARD COUNTY. CHECK WITH LOCAL AUTHORITY HAVING JURISDICTION FOR THE APPLICABILITY OF THIS TABLE WITHIN CERTAIN FLORIDA COUNTIES.

FRANK L. BENNARDO, P.E.

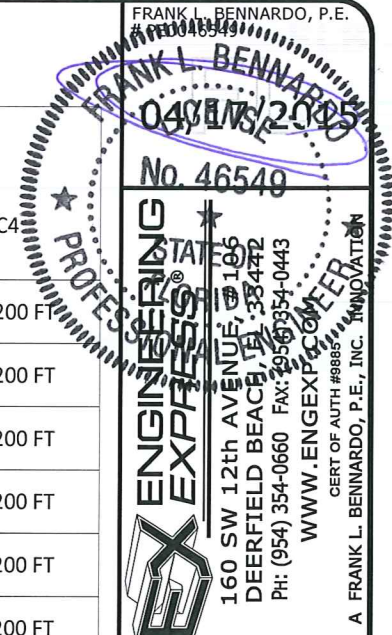

**BMP INTERNATIONAL, INC.**  
4710 28TH STREET NORTH  
ST. PETERSBURG, FL 33471  
PH: (727) 577-1613

MECHANICAL UNIT STEEL TIE-DOWN CLIPS  
FBC 5TH EDITION (2014) PRODUCT APPROVAL FL#14239.1

REMARKS	DRWN	CHKD	DATE
INIT ISSUE (11-BMP-0001)	FLB	TSB	12-11-11
REV FOR UNITS	CSL	TSB	02-15-13
REV FOR FBC 5TH (2014)	RWN	CSL	04-06-15

THIS DOCUMENT IS THE PROPERTY OF FRANK L. BENNARDO, P.E. AND SHALL NOT BE REPRODUCED IN WHOLE OR PART WITHOUT WRITTEN CONSENT OF FRANK L. BENNARDO, P.E. ANY UNAUTHORIZED REPRODUCTION OR USE OF THIS DOCUMENT IS NOT PERMITTED AND INVALIDATES OUR CERTIFICATION.

COPYRIGHT FRANK L. BENNARDO P.E.

15-2378

SCALE: N.T.S.

PAGE DESCRIPTION:

04/17/2015 - 3:56pm chen V:\Projects\15-2378 Air Handler Tiedown Clips - FSA - Update FL14239 for 2014 Florida Bldg C-Project.dwg