

## 2.0 – INSTALLATION GUIDE

### TABLE OF CONTENTS

2.1 – INTRODUCTION .....	P. 2-5
2.2 – USEFUL TOOLS & MATERIALS.....	P. 2-6
2.3 – ACCURATE FOOTINGS & SLABS.....	P. 2-8
2.3.1 – LOGIX FOOTING WITH FLEX BARS & XTENDERS .....	P. 2-9
2.4 – WALL LAYOUT .....	P. 2-10
2.5 – PRODUCT HANDLING & PLACEMENT.....	P. 2-11
2.6 – JOBSITE EFFICIENCY .....	P. 2-13
2.7 – LOGIX WALL CONSTRUCTION .....	P. 2-15
2.7.1 – THE FIRST COURSE .....	P. 2-17
2.7.2 – THE SECOND COURSE.....	P. 2-19
2.7.3 – ADDITIONAL COURSES .....	P. 2-21
2.7.4 – EXTENDED BRICK LEDGE.....	P. 2-23
2.7.5 – KNOCK-DOWN FORMS.....	P. 2-26
2.7.6 – LOGIX XRV PANELS.....	P. 2-29
2.7.7 – TEE WALLS.....	P. 2-31
2.7.8 – GABLE WALLS .....	P. 2-33
2.7.9 – RADIUS WALLS.....	P. 2-35
2.8 – REINFORCEMENT .....	P. 2-37
2.8.1 – BASIC PRINCIPLES OF REINFORCEMENT ...	P. 2-37
2.8.2 – HORIZONTAL REINFORCEMENT .....	P. 2-38
2.8.3 – VERTICAL REINFORCEMENT .....	P. 2-39
2.8.4 – LINTELS.....	P. 2-40
2.9 – WINDOW & DOOR BUCKS .....	P. 2-41
2.9.1 – TREATED PLYWOOD BUCK.....	P. 2-42
2.9.2 – SOLID WOOD BUCK.....	P. 2-43
2.9.3 – VINYL BUCK SYSTEM .....	P. 2-44
2.9.4 – RADIUS OPENINGS.....	P. 2-45
2.9.5 – METAL JAMBS .....	P. 2-47

## 2.0 – INSTALLATION GUIDE

<b>2.10 – ADDITIONAL FORM SUPPORT .....</b>	<b>P. 2-48</b>
<b>2.11 – WALL BRACING &amp; ALIGNMENT SYSTEM.....</b>	<b>P. 2-50</b>
<b>2.12 – FLOOR CONNECTIONS.....</b>	<b>P. 2-52</b>
2.12.1 – LEDGER WITH ANCHOR	
BOLTS & JOIST HANGERS.....	P. 2-53
2.12.2 – STEEL ANGLE IRON LEDGER .....	P. 2-54
2.12.3 – BRICK LEDGE FOR TOP & BOTTOM CHORD	
BEARING SYSTEMS.....	P. 2-56
2.12.4 – LEDGER WITH SIMPSON BRACKET & JOIST HANGERS .....	P. 2-57
2.12.5 – McMILLAN JOIST HANGERS .....	P. 2-60
2.12.6 – TRANSITION LEDGE .....	P. 2-61
2.12.6.1 – TRANSITION LEDGE WITH TAPER TOP FORMS.....	P. 2-62
2.12.6.2 – TRANSITION LEDGE WITH LOGIX TRANSITION FORMS .....	P. 2-63
2.12.6.3 – TRANSITION LEDGE WITH CORNER BLOCKS .....	P. 2-64
2.12.7 – TAPER TOP WITH SILL PLATE .....	P. 2-66
2.12.8 – CONCRETE FLOOR SYSTEMS .....	P. 2-67
2.12.8.1 – PRECAST CONCRETE FLOORS .....	P. 2-68
2.12.8.2 – HAMBRO FLOOR SYSTEM.....	P. 2-69
2.12.8.3 – STEEL COMPOSITE FLOOR SYSTEM	P. 2-70
<b>2.13 – ROOF CONNECTIONS .....</b>	<b>P. 2-71</b>
2.13.1 – INSET SILL PLATE .....	P. 2-72
2.13.2 – TOP MOUNTED SILL PLATE.....	P. 2-73
<b>2.14 – SERVICE PENETRATIONS.....</b>	<b>P. 2-74</b>

## 2.0 – INSTALLATION GUIDE

2.15 – CONCRETE PLACEMENT .....	P. 2-75
2.16 – ELECTRICAL INSTALLATIONS.....	P. 2-81
2.17 – PLUMBING INSTALLATIONS .....	P. 2-82
2.18 – INTERIOR & EXTERIOR FINISHES.....	P. 2-83
2.18.1 – VAPOR & AIR BARRIERS.....	P. 2-83
2.18.2 – INTERIOR DRYWALL .....	P. 2-84
2.18.3 – EXTERIOR SIDING .....	P. 2-86
2.18.4 – STEEL PANEL SIDING .....	P. 2-87
2.18.5 – WOOD SIDING.....	P. 2-88
2.18.6 – EIFS .....	P. 2-89
2.18.7 – TRADITIONAL STUCCO (CEMENT-BASED) .....	P. 2-90
2.18.8 – CEMENT COMPOSITE SIDING .....	P. 2-90
2.18.9 – BRICK VENEER.....	P. 2-91
2.18.10 – BELOW GRADE WATERPROOFING, DAMPPROOFING & PARGING.....	P. 2-92
2.18.10.1 – BELOW GRADE WATERPROOFING	P. 2-93
2.18.10.2 – ABOVE GRADE PARGING .....	P. 2-95
2.18.11 – ADDITIONAL SUPPORT FOR GRAB BARS, & OTHER HEAVY FIXTURES .....	P. 2-96
2.18.12 – HOLDING POWER OF SCREWS FASTENED TO LOGIX FURRING TABS.....	P. 2-97
2.19 – COURSE HEIGHT TABLE.....	P. 2-98
2.20 – RADIUS WALLS .....	P. 2-99
2.21 – TALL WALLS .....	P. 2-108
2.22 – TILT-UP WALL CONSTRUCTION .....	P. 2-110
2.23 – SUPPORTING PRODUCTS.....	P. 2-114



## 2.1 – INTRODUCTION

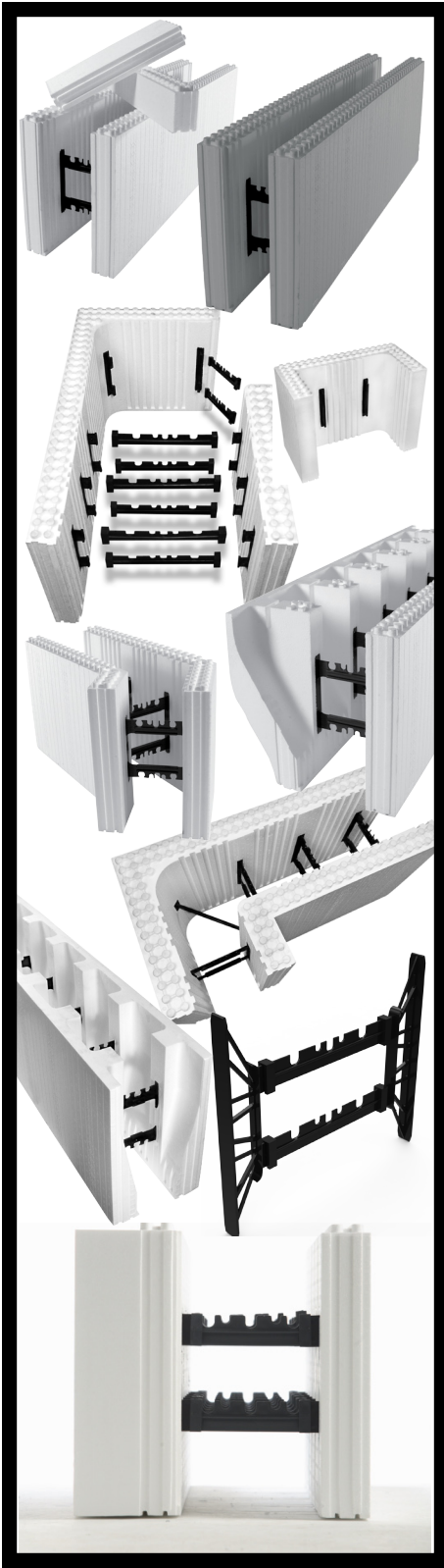

For builders who want a competitive edge, LOGIX offers solid products and friendly local service. Our products are designed to perform better in the field, providing trouble-free, profitable installations time after time. Our technical team is ready to respond to your queries with practical advice on quick and efficient installation. With contractor training provided through our numerous regional technical support offices, help is always close at hand. We are the most experienced ICF manufacturers in North America, manufacturing top quality products at our nine plants located throughout the United States and Canada.

For more information, or to contact a LOGIX representative, visit our website at [www.logixicf.com](http://www.logixicf.com) and click "Contact Us". You can also register online to receive LOGIX updates.

This manual will be updated regularly. Current updates will be available at [www.logixicf.com](http://www.logixicf.com).

You can count on LOGIX. The ICF wall system that's built to last.

## 2.2 – USEFUL TOOLS & MATERIALS



INSTALLATION GUIDE

- Pruning saw
- Cordless drill
- Screws
- Hot knife
- Electric chainsaw
- Fiberglass-reinforced tape
- Step ladder
- Rebar bender/cutter
- Internal vibrator
- Contractor-grade foam gun
- Low expansion foam adhesive
- Approved scaffold planks
- Transit or laser
- 48" (1220mm) level
- Bolt cutters
- String line

## 2.2 – USEFUL TOOLS & MATERIALS

CONTINUED



- Chalk line
- Wall alignment system (safety compliant)
- 36 inch (914 mm) plastic zip ties
- Concrete embedments
- Window and door buck material
- Sleeves for wall penetrations

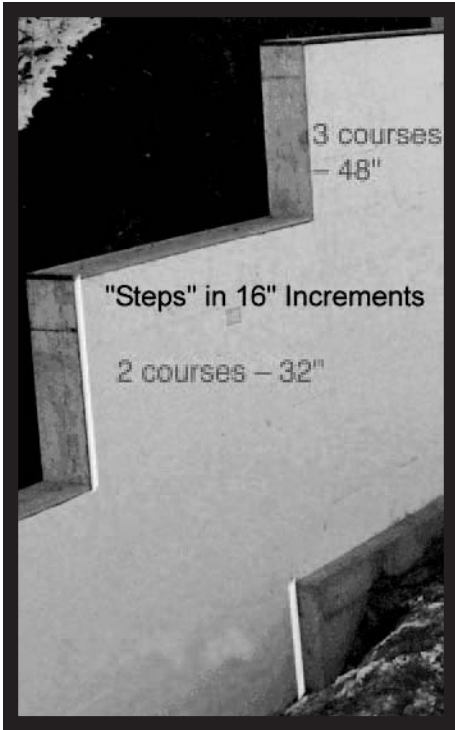

## 2.3 – ACCURATE FOOTINGS & SLABS

The first step to a successful LOGIX installation is an accurate footing or slab. This means a footing or slab that is:

- Code compliant
- Designed in accordance with construction drawings and specifications
- Designed taking into account soil conditions, seismic area, number of stories, building loads, and water tables.



see section 6.0 – Engineering

STEP 1: Level footings with +/-1/4 inch (+/-6 mm).

STEP 2: Place footing dowels or keyways as required per plan specification or local building codes.

STEP 3: Once footing dowels are installed, cap all dowels for safety compliance.

The ideal increment for step footing is 16 inches (406 mm). Using LOGIX Half-height forms, Height Adjusters or Flex Bars it is possible to achieve 8 inch (203 mm), 4 inch (102 mm) or 2 inch (51 mm) footing increments, respectively.

## 2.3.1 – LOGIX FOOTING WITH FLEX BARS & XTENDERS

Building a footing with LOGIX can be done using LOGIX Flex Bars and Double Brick ledge.

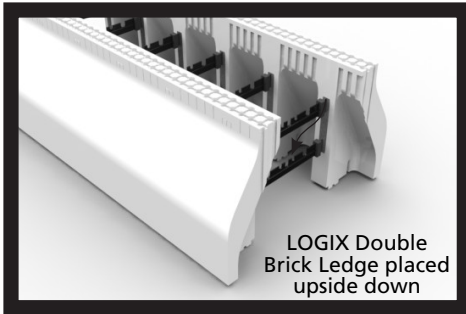

**STEP 1:** Place the Double Brick Ledge upside down along the footing locations. With the Double Brick Ledge placed upside down the female interlocks will be at the top of the block. This means for the next course male/male LOGIX Flex Bars will be used.

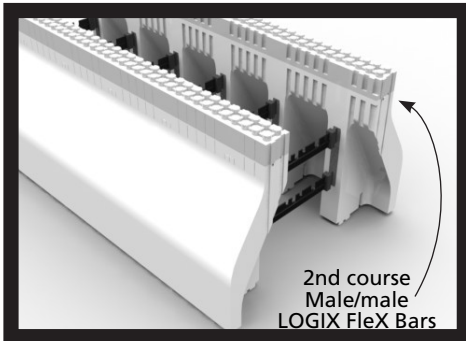

**STEP 2:** Place the 2nd course using the male/male LOGIX Flex Bars.

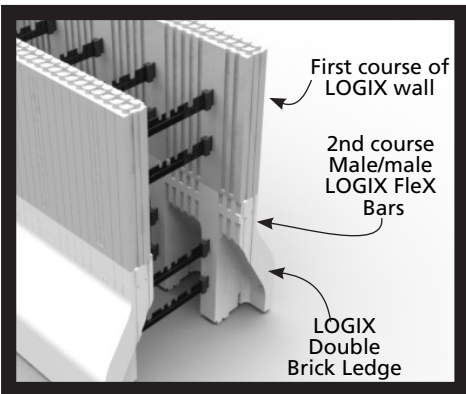

**STEP 3:** Continue building the wall with LOGIX blocks for the remaining courses.

Be sure to add required reinforcement while placing courses, and install bracing as typically required.

To secure the courses of LOGIX Flex Bars in a LOGIX wall use zip ties to firmly connect the course below and above the LOGIX Flex Bars, and add additional form support where needed.

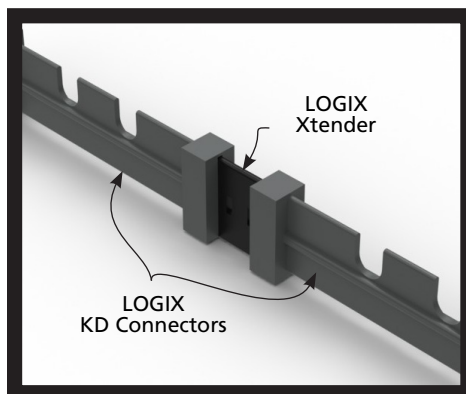

As an alternative to using Double Brick Ledge forms, LOGIX Standard form panels can be used with LOGIX Xtenders. LOGIX Xtenders increase the LOGIX concrete core thickness beyond 12 inches (305mm) to any footing width required.

## 2.4 – WALL LAYOUT



Accurate wall layout is critical to ensure a complete and profitable LOGIX project.

**STEP 1:** Verify that wall layout is in accordance with plans and specifications.

**STEP 2:** To ensure accurate 90° corners, use methods such as:

- Equal diagonal measurements
- 3-4-5 triangle
- Surveying

**STEP 3:** To ensure accurate 45° corners, use LOGIX 45° corner form units.

**STEP 4:** Snap chalk lines on footings or slab according to plan.

**STEP 5:** Make sure the outside face of the forms line up with the overall building dimensions.

Wall layout of radius or other corner angles is easily achieved with LOGIX.



## 2.5 – PRODUCT HANDLING & PLACEMENT



There are several methods to efficiently handle LOGIX forms. Unlike most ICF systems, the consistent 2-3/4 inch (70 mm) panel thickness on LOGIX forms means that handling damage is minimized. LOGIX XRV panels can also provide thicker panels up to 8 inches (203 mm)

- LOGIX Standard Forms arrive stacked on disposable skids.
- The forms are strapped together for easy handling.
- Unloading can be accomplished manually or using alternate lifting equipment.
- Standard forms can be moved by two people using two 2x4s
- Corner forms come in bundles of four or twelve, and can easily be carried by one or two people.
- Specialized dollies are another convenient way to move LOGIX bundles.
- When transporting forms on an open trailer, position the forms so the wind travels through the webs to minimize drag.
- When tying forms down on an open trailer, ensure the forms are well secured and avoid form damage from strapping materials.
- If job site conditions require form protection, LOGIX bundle bags can be ordered.

## 2.5 – PRODUCT HANDLING & PLACEMENT

CONTINUED



- LOGIX forms are produced to the tightest tolerance in the industry, with a length tolerance of  $\pm 1/8$  inch ( $\pm 3$  mm), and a height tolerance of  $\pm 1/16$  inch ( $\pm 2$  mm).

When forms are unloaded, it is necessary to measure forms to determine uniform length and height. It is suggested to measure 2 forms per skid. In the unlikely event that forms are out of spec, please contact the local LOGIX representative immediately.

I  
N  
S  
T  
A  
L  
L  
A  
T  
I  
O  
N  
G  
U  
I  
D  
E

Good. Solid. Green.™

[www.logixicf.com](http://www.logixicf.com)

2 – 12

**LOGIX**®  
INSULATED CONCRETE FORMS

REPRINTED 2011

Rev. Sep 23/09

## 2.6 – JOBSITE EFFICIENCY



An efficient jobsite means a faster and safer installation, and ultimately a higher quality finished project.

- Keep all materials and tools outside of the footing area until the chalk lines have been snapped and the wall layout is complete. Generally, construction is accomplished from within the perimeter of the structure.
- When wall layout is complete, place forms at least 7 feet (2.134 m) inside the perimeter of the footings or slab to accommodate the wall alignment system.
- Space skids of standard forms around the inside of the entire perimeter.

**ALERT:** When placing courses of forms, always take forms from the closest skid. This will eliminate the effects of normal manufacturing variations between skids.

- Periodic checking of dimensions ensures accurate wall construction.

## 2.6 – JOBSITE EFFICIENCY

CONTINUED

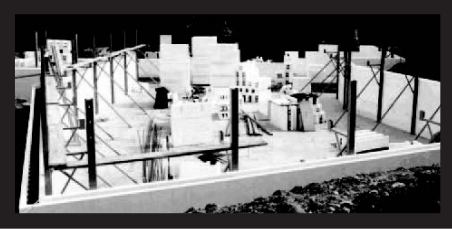

- Additional materials that should be located within the perimeter:

- Window and door bucks
- Rebar (straight or pre-bent)
- Alignment system
- Approved scaffold planks
- Tools

## 2.7 – LOGIX WALL CONSTRUCTION



**BARS**  
The spaces between the lines.

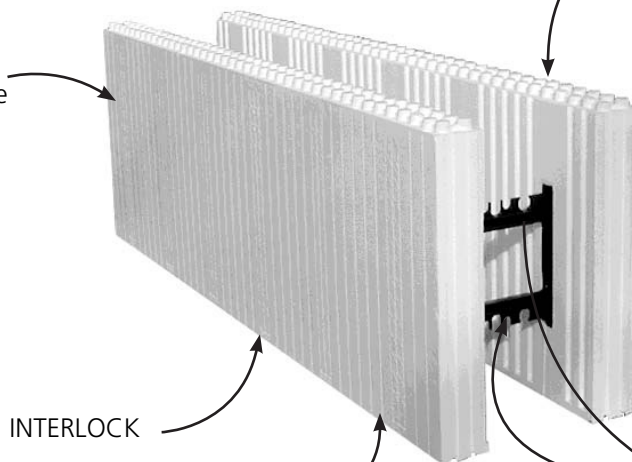

**INTERLOCK**  
The mechanism that holds successive courses of forms together.

**INTERLOCK**

**WEB**  
polypropylene ties that holds the form unit together. The web also acts as the placement mechanism for reinforcing steel and the attachment surface for finish materials. There are six webs in each form unit.

**LINES**  
The lines between the bars allow cuts to be easily made that will allow the interlock to function consistently between courses. Cuts should always be made straight and square on the lines. Cutting anywhere but along these marks will create a stacked vertical joint.

## 2.7 – LOGIX WALL CONSTRUCTION

CONTINUED

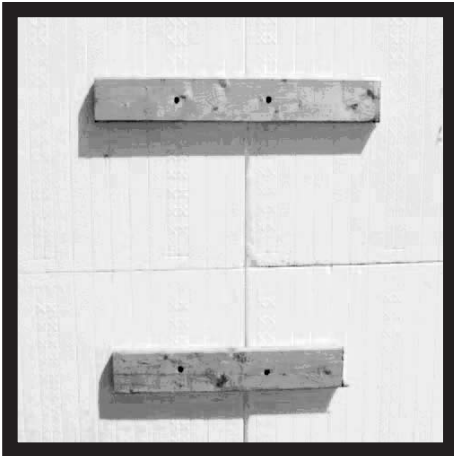

When a form is cut, it can be identified using bars and webs. For example, a cut form with three bars, two webs, and three bars will be referred to as a “3-2-3”.

By establishing a logical form pattern that takes into account the building dimensions, maximum efficiency will be achieved. It is important that the building dimensions have a tolerance of +/-1/2” inch (13 mm) or a stacked vertical joint will result. Such joints are acceptable if dimensions necessitate but will require additional form support on both sides of the form.

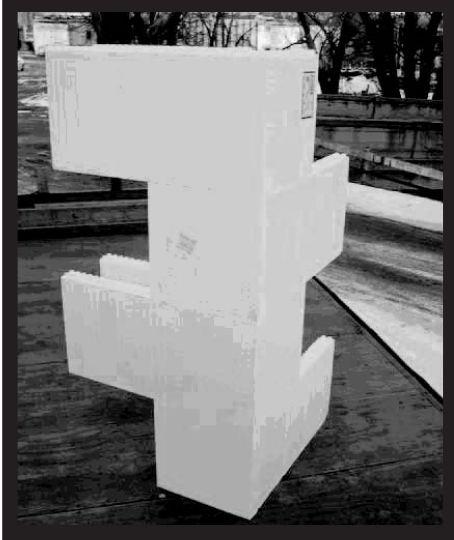

When building dimensions are based on 4 feet (1.219 m) increments, it is suggested to use all left or all right hand corners in each courses, alternating between subsequent courses.

INSTALLATION GUIDE

## 2.7.1 – THE FIRST COURSE



**STEP 1:** Always place forms units with protruding interlock facing up.

**STEP 2:** Begin at a corner. Set corner block to chalk line.

**STEP 3:** Continue placing forms along the chalk line.

**STEP 4:** Secure forms end-to-end in the first course to maintain building dimensions.

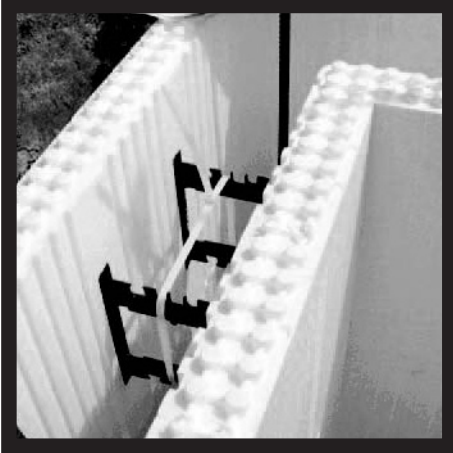

**STEP 5:** When the forms are within 4 feet (1.219 m) or less of the second corner, place the second corner form.

**STEP 6:** Cut a standard form to fit the space left between the corner and the previous form. At this point, determine if adjustments are needed to the building dimensions so the cut can be made on a line.

If adjustments are needed, alter chalk lines accordingly.

If more than 3 bars are extending beyond any web, additional form support is required on both faces of the form.



## 2.7.1 – THE FIRST COURSE

CONTINUED



**STEP 7:** Continue around the wall in this manner until the first course is complete and dimensions are verified.

Leave the first course of forms in place across door openings and low windows until forms have been placed and building dimensions have been verified to maintain the interlock pattern above openings.

**STEP 8:** Place necessary rebar in first course as specified and according to local code.

**STEP 9:** Prior to starting the second course, install additional form support if required.

## 2.7.2 – THE SECOND COURSE



**STEP 1:** Starting at the original corner, place appropriate corner form to create a 16" (406mm) offset.

**STEP 2:** Fasten every corner end-to-end to adjoining forms using zip ties or adhesive foam.

**STEP 3:** Continue placing forms around the wall, working in the same direction as first course.

**STEP 4:** It is necessary to seat every form to the form below to minimize interlock settling during concrete placement.

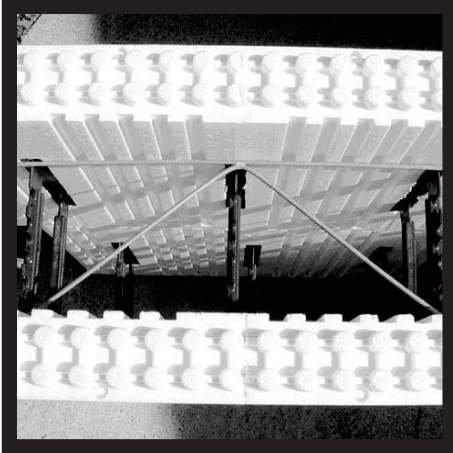

**STEP 5:** All webs should line up vertically, except where building dimensions are other than 8 inch (203 mm) increments.

**STEP 6:** After completion of second course, place necessary rebar as specified and according to local code.



**STEP 7:** Place Form Lock in the second course, overlapping the lengths by roughly 8 inch (203 mm). Align the points of the zigzag pattern in the Form Lock directly above the webs.

**STEP 8:** Confirm that the wall is straight and level. If adjustment is required, shim or trim the bottom of the wall until level is achieved.

## 2.7.2 – THE SECOND COURSE

CONTINUED



**STEP 9:** Use foam adhesive to fasten the straightened and levelled wall to the footing or slab. Insert the  nozzle 1 inch (25 mm) at the base of every other web along the chalk line and inject foam between the block and the footing.

When vertical joints are less than 8 inches (203 mm) apart, additional form support is required.

It is important to note that at this point the wall pattern has been established. Course number 1 will be the pattern for all odd numbered courses (3, 5, 7, etc.). Course number 2 will be the pattern for all even numbered courses.

Wall alignment system to be installed at some point between the second and fourth courses, at no more than 7 feet (2.134 m) intervals. See **Section 2.11 - Wall Bracing & Alignment System** for further details.

I  
N  
S  
T  
A  
L  
L  
A  
T  
I  
O  
N  
G  
U  
I  
D  
E



## 2.7.3 – ADDITIONAL COURSES



**STEP 1:** Fasten every corner end-to-end to adjoining forms using zip ties or adhesive foam.

**STEP 2:** Install Form Lock every fourth or fifth course after the second course.

**STEP 3:** After completion of each course, place necessary rebar as specified and according to local code.

**STEP 4:** Secure forms end-to-end in the top course to maintain building dimensions.

**STEP 5:** Secure top course to the forms below on both sides to prevent tipping during concrete placement.

**STEP 6:** If additional stories are planned, the interlock needs to be protected prior to concrete placement.

Female/female LOGIX Fusions Bars can be used on the top of the wall to protect the interlocks during the pour.

**STEP 7:** Check building dimensions. Check corners for plumb.

**STEP 8:** Ensure straight walls by placing a string line at the top course set off from the wall using 3/4 inch (19 mm) pieces of wood placed in the corners. Check for straightness by running another 3/4 inch (19 mm) piece of wood between the string and wall.

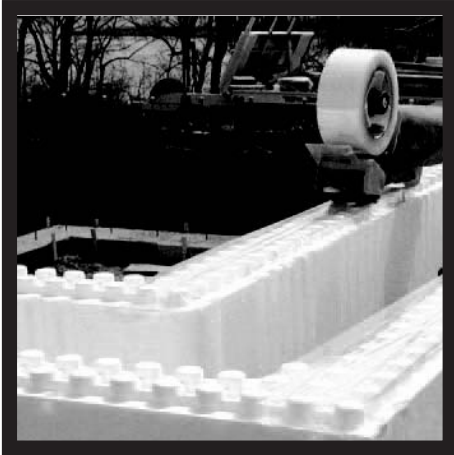

## 2.7.3 – ADDITIONAL COURSES

CONTINUED

When vertical joints are less than 8 inches (203 mm) apart additional form support is required.

If you need to stack identical corners in subsequent courses, you will need to provide additional form support where the stacked joints are created.

Hold all reinforcement back 2 inches (51 mm) from door and window buck material to ensure proper concrete coverage.

## 2.7.4 – EXTENDED BRICK LEDGE

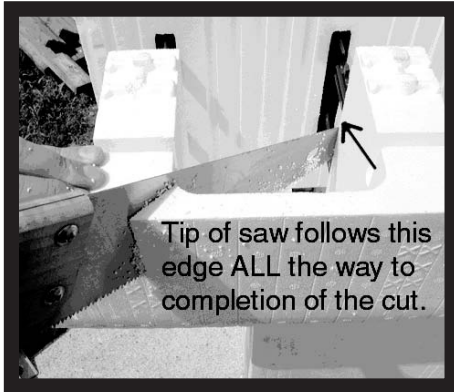
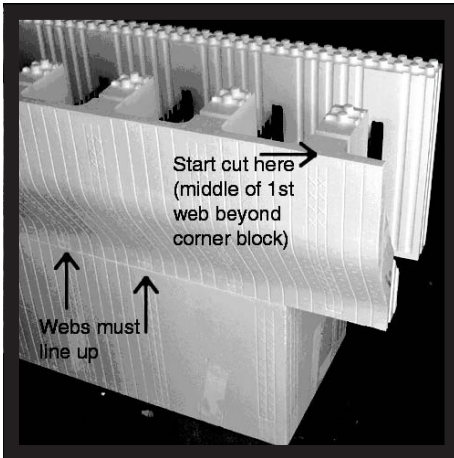

Brick Ledge forms come only in straight units, so mitered cuts on site must be made to create corners with these blocks. Two methods can be used:

1. Freehand miter cutting.
2. Using a template.

On a 6.25 inch (159 mm) LOGIX Brick Ledge always start a miter cut in the middle of the first web beyond the corner form.

When making any miter cut in a Brick Ledge form to create a 90° corner always angle the saw and make sure you follow this edge during the ENTIRE course of making the cut.

Extending a Brick Ledge block two webs beyond the corner block and making the cut will create a remaining piece that can be used for an inside corner elsewhere in the layout.

**STEP 1:** The first portion of the cut is vertical, then angle to the tip of the corner block below, always keeping the tip of the saw following the inside edge.

**STEP 2:** After making the miter cut, cut the far side of the block so it is flush with the inside edge of the corner form.

## 2.7.4 – EXTENDED BRICK LEDGE

CONTINUED

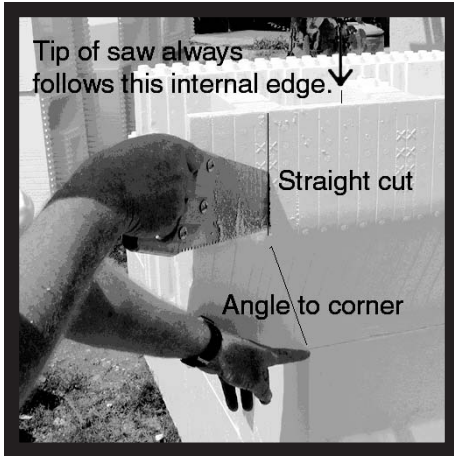

**STEP 3:** Place the second Brick Ledge in place to cut on the opposing side of the corner.

**STEP 4:** Cut the second Brick Ledge miter in a manner similar to the first miter.

When cutting the inside panel of the second mitered block, make the cut so it butts against the opposing panel.



**STEP 5:** Securely tape and foam the mitered corner, applying several rows of tape.

**STEP 6:** Install rebar in the Brick Ledge, making sure to install two 90° pieces extending 2 feet (0.610 m) in either direction.

Butt joints are preferred for rebar in outer edge of Brick Ledge.



**STEP 7:** Install long stirrups in each brick ledge cavity, including the every corner. See **Section 5** for stirrup details.

INSTALLATION GUIDE

## 2.7.4 – EXTENDED BRICK LEDGE

CONTINUED

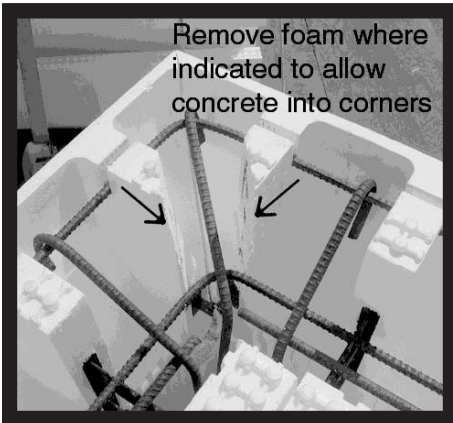

**STEP 8:** Remove foam from the corner cavity area to facilitate the flow of concrete into the corner cavity.

## 2.7.5 – KNOCK-DOWN FORMS

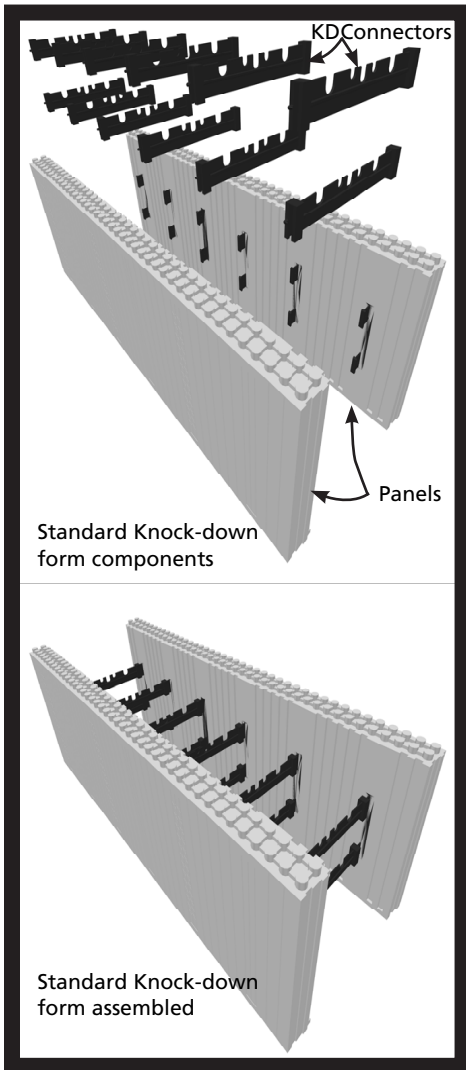

LOGIX Knock-down forms (LOGIX KD) are designed to offer the same benefits as the LOGIX solid forms (LOGIX PRO). However, LOGIX KD forms also

- reduce shipping costs and inventory requirements
- accommodates tilt-up wall panel construction
- allows hassle-free assembly of forms around complex rebar patterns (i.e. stirrup or rebar cage pattern in walls)
- allows custom block configurations (i.e. Taper Top-Brick Ledge, Transition block-Transition block, etc...)

### PRODUCT DESCRIPTION

LOGIX KD forms consists of two expanded polystyrene (EPS) foam panels measuring 16 inches (406 mm) tall x 48 inches (1220 mm) wide x 2.75 inches (70 mm) thick. The panels are connected using KD Connectors, snap-in polypropylene ties spaced 8 inches (203 mm) on center to form the ICF. The KD Connectors are available in varying sizes that create 6.25, 8, 10 and 12 inch (159, 203, 254 and 305 mm) thick concrete walls. Corner panels are also available.

## 2.7.5 – KNOCKDOWN FORMS

CONTINUED

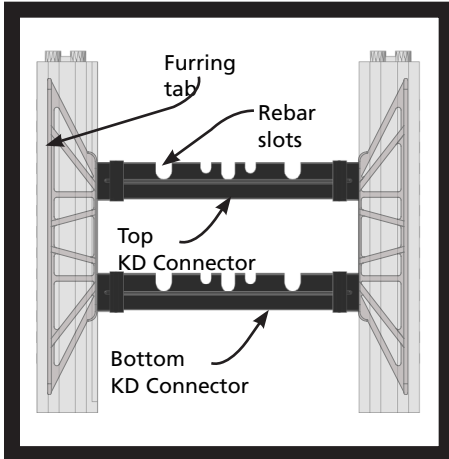

### PRODUCT HANDLING

There are several methods to efficiently handle LOGIX KD forms. The high foam density and consistent 2-3/4 inch (70 mm) panel thickness on LOGIX KD means that handling damage is minimized. In addition, LOGIX XRV panels provide panel thickness up to 8 inches (203 mm). See next section for information on LOGIX XRV panels.

The forms arrive on-site unassembled. KD Connectors and panels arrive on-site packaged in boxes and bundled in stacks, respectively.

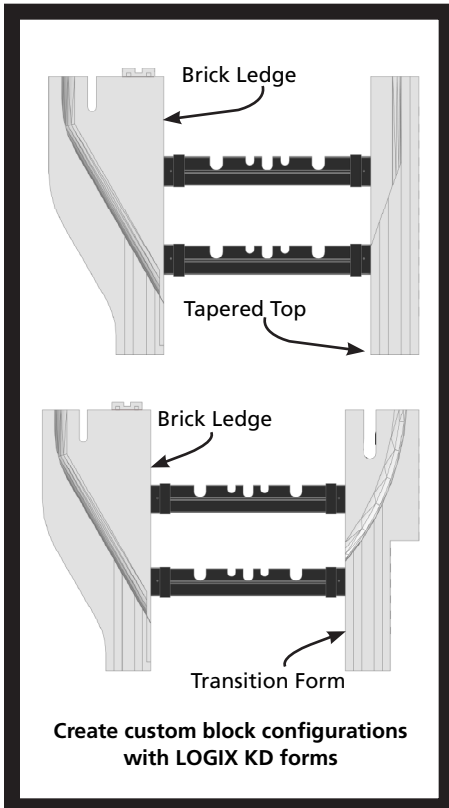

### ASSEMBLING AND INSTALLATION

The KD Connectors connect to the polypropylene furring tabs embedded in the form panels. The furring tabs are spaced at 8 inches (203 mm) on center and act as solid attachment areas for drywall, cladding and other wall attachments. A top and bottom KD Connector is required for each furring tab.

To assemble the forms simply snap into place the top and bottom KD Connectors with the rebar slots facing upwards. This will accommodate two layers of rebar.

As the forms are assembled on-site they are stacked in place to form the walls. Stacking the blocks, including required tools, are the same when using LOGIX Pro forms.

## 2.7.5 – KNOCKDOWN FORMS

CONTINUED

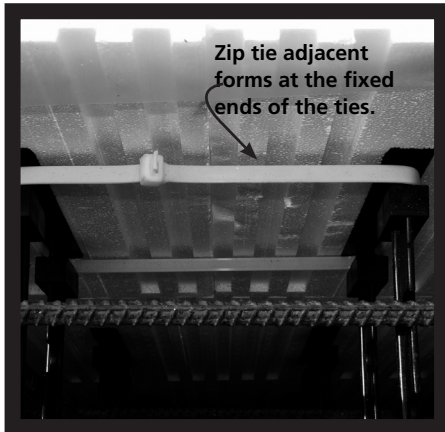

In addition, LOGIX recommends the following:

- Use foam adhesive, 2x4s, steel stud angles or other system that will keep the first course in place and properly aligned during the initial concrete pour.
- Zip tie adjacent forms at the fixed ends of the ties.
- Install bracing every 6 ft.
- Provide additional form support at corners of 12" LOGIX KD forms.

### CORNER FORM SUPPORT

For any type of ICF knock-down system it is good practice to provide additional form support at the corners for 12" LOGIX KD forms.

To ensure a safe and proper concrete pour the following corner form support is recommended:

- Using 2.5 inch (64 mm) wood screws to fasten 2x6 vertically to the embedded furring tabs on both sides of the corner.
- For outside corners wrap steel strapping around the corners. For the bottom third of the concrete pour height evenly space two strappings for each course. Then one strap per course for the remaining pour height. Using 1.5 inch (38 mm) wood screws the bands should attach to at least two furring tabs that extend beyond the 2x6 on both sides of the corner.
- For inside corners apply typical bracing as required.

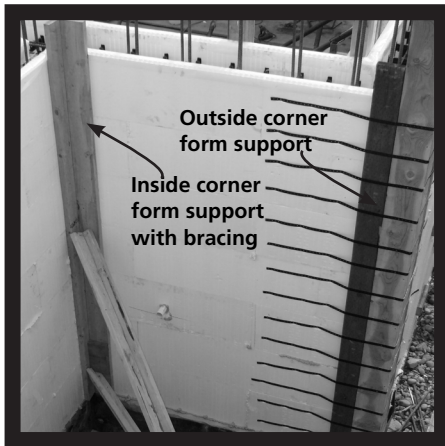

## 2.7.6 – LOGIX XRV PANELS

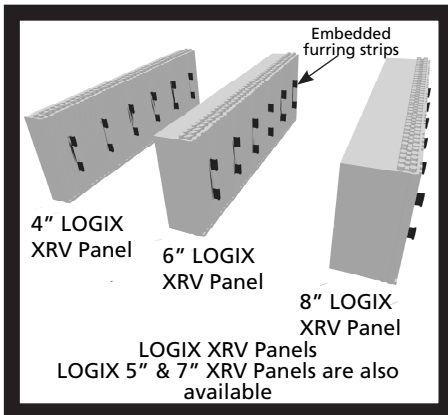

LOGIX XRV Panels are most useful for buildings in areas requiring higher energy savings or higher insulation values, such as places with extreme temperature swings or extremely cold climates. The LOGIX XRV Panels can provide R-values ranging from R-28 to R-66\* by increasing the foam panel thickness from 2.75 inches (70 mm) to 8 inches (203 mm).

LOGIX XRV Panels are available in thicknesses of 4, 5, 6, 7 and 8 inches (102, 127, 152, 178 and 203 mm) and can be used to build walls with concrete cores of 4, 6.25, 8, 10 and 12 inches (102, 159, 203, 254 and 305 mm) thick. LOGIX XRV Panels employ the same tight fitting and secure interlock system found in LOGIX Pro (assembled forms) and the same furring tabs found in LOGIX KD forms. Thus LOGIX XRV Panels can be used in conjunction with LOGIX Pro and LOGIX KD.

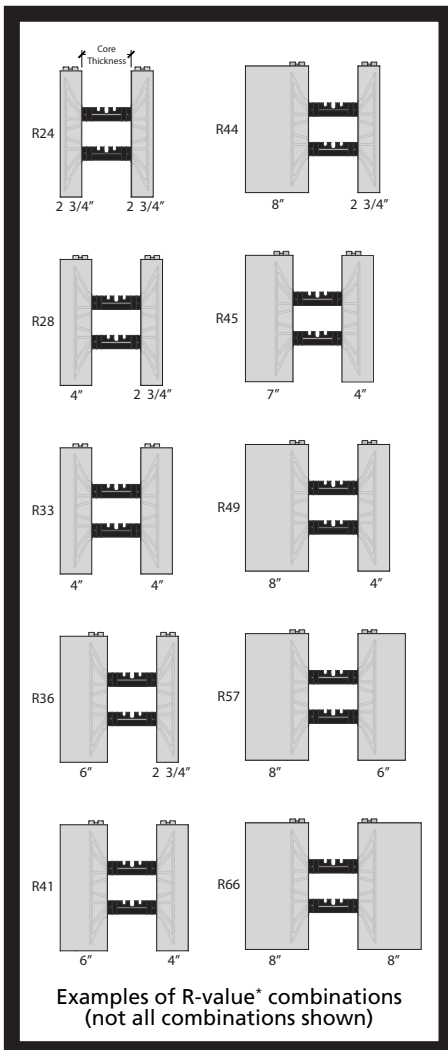

### STUCCO FINISHES

Cement or acrylic based stucco finishes should be applied according to manufacturer's installation instructions. When attaching wire mesh non-corrosive screws are recommended along with the minimum screw lengths listed below.

Minimum Fastener Lengths
4" LOGIX XRV Panels - 2.75"
5" LOGIX XRV Panels - 3.75"
6" LOGIX XRV Panels - 4.75"
7" LOGIX XRV Panels - 5.75"
8" LOGIX XRV Panels - 6.75"

Long screws and accessories for stucco applications are available through Wind-Lock at [www.wind-lock.com](http://www.wind-lock.com).

\*R-values include LOGIX ICF with minimum 4" concrete wall thickness and airfilm.

## 2.7.6 – LOGIX XRV PANELS

CONTINUED

INSTALLATION GUIDE

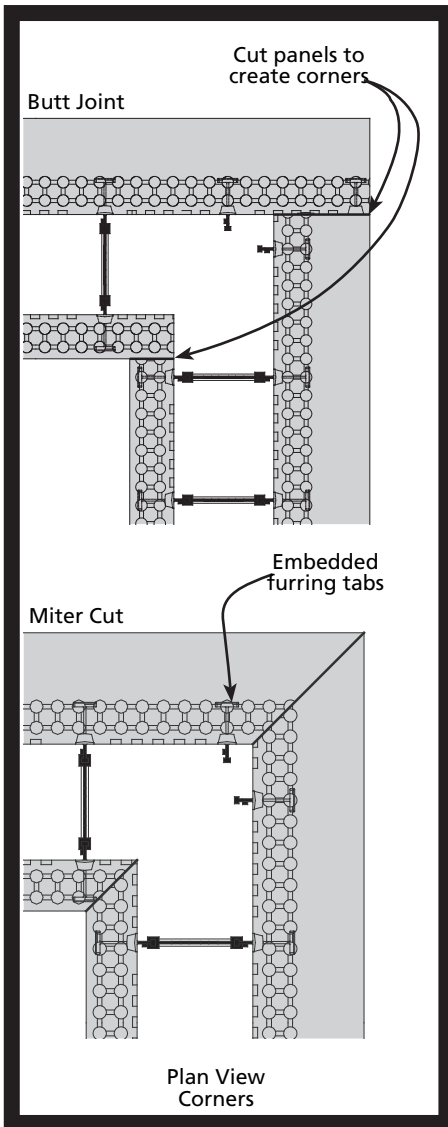

In addition, plastic or fibre mesh can be attached to a base coat applied over the LOGIX XRV Panel surface that has been prepared by rasping the surface.

### CORNERS

Corners with LOGIX XRV Panels can be created with butt joints or miter cuts. The cuts should be made so that the embedded furring tabs are close to the corner edges. This will provide fastening points for form support and other corner attachments.

Make sure to add additional form support around the corners prior to placing concrete, and avoid placing concrete directly in the corners of LOGIX XRV Panels.

When applying stucco finishes attaching a corner bead or wrapping a plastic or fibre mesh in a base coat around the corners can add strength to the corners.

### VERSATILITY

LOGIX is versatile enough to offer a choice of panel thickness, core thickness and web type. For a list of LOGIX KD and XRV combinations see **Section 8.1**.

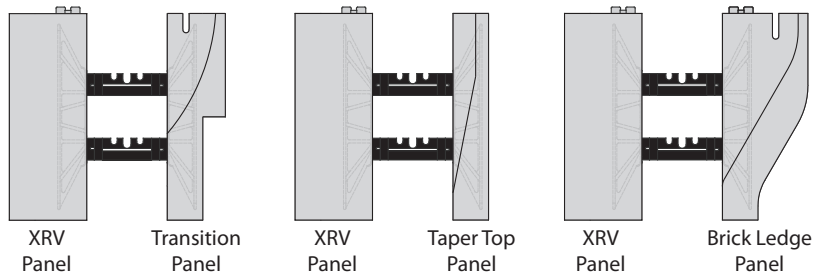

## 2.7.7 – TEE WALLS

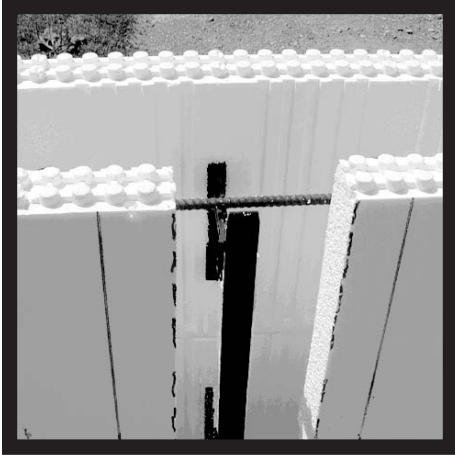

Each course of the through wall must have continuous horizontal bar or a minimum of 3 feet (0.914 m) length of rebar at proposed Tee. A pre-bent 90° rebar is required at every course of rebar.

**STEP 1:** Complete the first course of the “Through” (continuous) wall.

**STEP 2:** Use a felt-tip marker to mark the through wall where the Tee wall will butt against it.

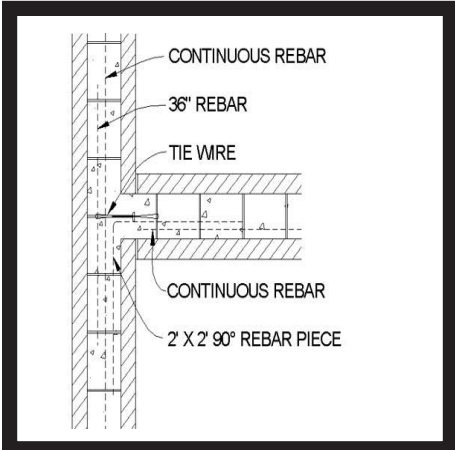

**STEP 3:** Remove the foam from the Through wall where the Tee intersects, to the thickness of the concrete core.

**STEP 4:** Butt the first course of the Tee up against the Through wall.

**STEP 5:** Tie the first Tee wall web to the Through wall rebar using a zip tie or tie wire. A short length of rebar should be placed behind the face of the web that is being tied to stiffen it.



For full size CAD drawing see Section 5, CAD Drawings

**STEP 6:** Additional exterior form support should be installed as required at every course.

## 2.7.7 – TEE WALLS

CONTINUED

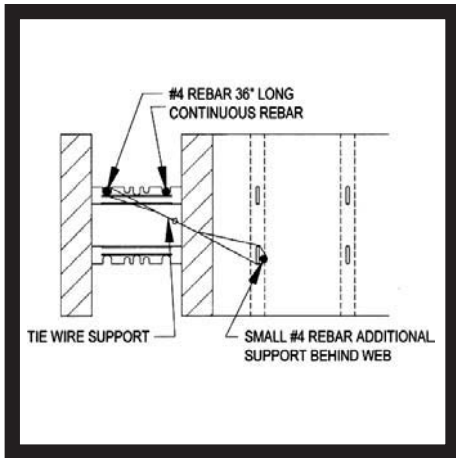

**STEP 7:** Continue building the walls, following these steps at every course.

**STEP 8:** When the entire wall has been checked for plumb and square, apply foam adhesive to the entire butt joint.

Another option for building a Tee wall is to construct the entire Through wall first. This method requires pre-planning to ensure there is a adequate reinforcements at every course to allow the Tee wall to be attached securely. All other steps above need to be applied.



For full size CAD drawing see Section 5, CAD Drawings

I  
N  
S  
T  
A  
L  
L  
A  
T  
I  
O  
N  
G  
U  
I  
D  
E

## 2.7.8 – GABLE WALLS

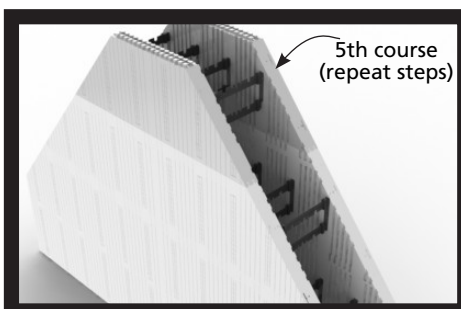
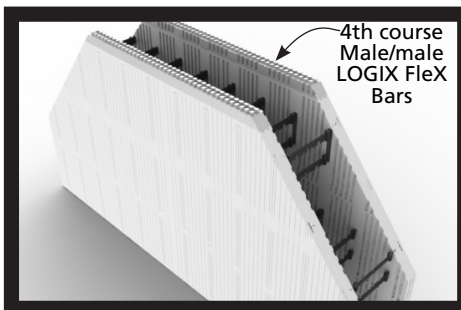
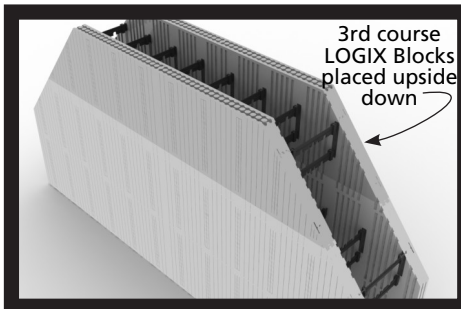
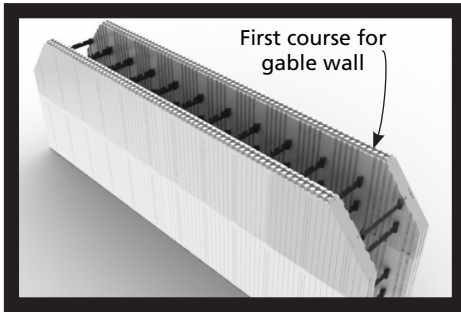

Gable walls can be constructed efficiently and with minimal job site waste using LOGIX Flex Bars.

The preferred method to construct a gable end is on the floor to be installed as a one-piece unit.

**STEP 1:** Lay the first course of LOGIX blocks for the gable wall.

**STEP 2:** Snap a chalk line for the sloped gable cuts and cut the LOGIX blocks to match the required gable slope at the ends of the wall. Save the remaining cut blocks for later use.

Gable cuts can be made with a pruning, reciprocating or other type of saw.

**STEP 3:** Place the 2nd course with female/female LOGIX Flex Bars. Cut the LOGIX Flex Bars to match the required gable slope at the ends of the wall. Save the remaining cut Flex Bars. They can be used for the end of the gable wall when placing another course of Flex Bars.

**STEP 4:** Lay the 3rd course of LOGIX blocks upside down so that the male interlocks of the LOGIX blocks match the female interlocks of the LOGIX Flex Bars from the previous second course. Use the saved cut pieces from the first course for the ends of the gable wall. These pieces when placed upside down will match the gable slope.

## 2.7.8 – GABLE WALLS

CONTINUED

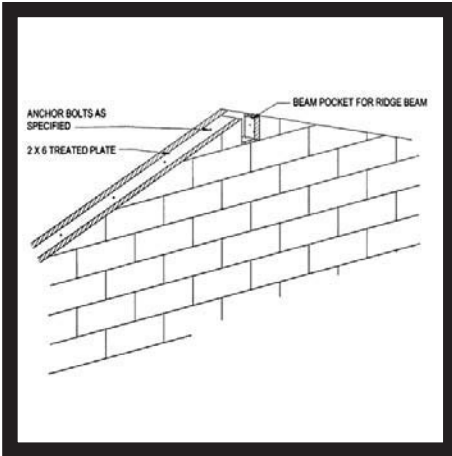

**STEP 5:** Place the 4th course with male/male LOGIX Flex Bars. Cut the LOGIX Flex Bars to match the required gable slope at the ends of the wall. Save the remaining cut Flex Bars. They can be used for the end of the gable wall when placing another course of Flex Bars.

**STEP 6:** Continue the process to complete the gable wall.

- Zip tie successive courses of LOGIX blocks, and ensure that webs align vertically between courses.
- Screw 1x4s along the cut gable slope on both sides of the wall. Pieces of plywood can then be screwed into the 1x4s to help contain the concrete during placement.
- Check rebar is in place prior to concrete placement, and all necessary and roof attachment hardware is available, as it must be installed during or immediately after the pour.
- Use appropriate lifting equipment to place the sloped gable wall in place on the squared wall.
- Ensure that appropriate wall alignments and scaffolding system is in place for safe installation.

Another option for constructing a gable wall is to assemble the gable in place. Set the pitch for the gable by marking the first course appropriately. Subsequent courses should follow this pattern.

INSTALLATION GUIDE



## 2.7.9 – RADIUS WALLS

Radius walls are easy to achieve with LOGIX.

**STEP 1:** Cut forms into 8 inch (203 mm) increments with web in center of each section.

**STEP 2:** Mark the inside and outside diameter of the curved wall on the footing or slab.

**STEP 3:** From the center of the circle, snap a radius line to the outside diameter line. This becomes your center radius for the next step.

**STEP 4:** On the outside diameter line, snap a radius line 4" (102mm) on each side of the center radius.

**STEP 5:** Set on of the 8 inch (203 mm) form sections, centering the web on the center radius. Line up the outside corners of the form section with the outside radius lines.

**STEP 6:** Mark the form section at the outside radius lines, and cut angles accordingly.

**STEP 7:** This form section now becomes a template, form which you can cut the other sections. Mark and cut all form section accordingly.

## 2.7.9 – RADIUS WALLS

CONTINUED

**STEP 8:** Zip ties, tape, or foam can now be used to connect all the form section into the wall. Repeat the steps for each course of radius wall.

**STEP 9:** This process will result in vertically stacked joints, and additional form support will be required prior to concrete placement.

## 2.8 – REINFORCEMENT

### 2.8.1 – BASIC PRINCIPLES OF REINFORCEMENT



Reinforcing steel (rebar) strengthens concrete walls to help minimize cracking and buckling under load due to backfill, wind, and other loads. Rebar also helps control cracking due to temperature swings and shrinkage.

A non-contact splice is typically the splice of choice in LOGIX walls except in heavily reinforced walls or in cases of narrow wall cavities.

Reinforcement around windows and doors needs to be installed as required.



Reinforcing steel must meet the requirements of ASTM A615, ASTM A996, or ASTM A706 for low-alloy steel. Minimum of Grade 40 (300MPa).

Reinforcing steel in a LOGIX wall must have minimum 3/4 inch (19 mm) concrete cover.

 see section 6.0 – Engineering

Refer to LOGIX Design Manual for reinforcing tables or refer to EB118.



It is the responsibility of the installer to verify table rebar specifications with local building codes and engineer specs.

## 2.8.2 – HORIZONTAL REINFORCEMENT



**STEP 1:** Horizontal rebar, sized as required, should be placed in the wall as each course is installed.

**STEP 2:** Hold the reinforcement back from door and window openings by 2" (51mm).

**STEP 3:** Maintain the proper overlap splice length of 40d (40 x bar diameter) or 24 inch lap length, whichever is greater, or as otherwise specified when placing horizontal rebar. A non-contact lap splice is recommended.



**STEP 4:** The notch pattern on the LOGIX web allows for horizontal rebar to be alternated in location, course by course. This allows ideal support and positioning for vertical steel. Vertical rebar diameter will dictate horizontal offset from course to course.

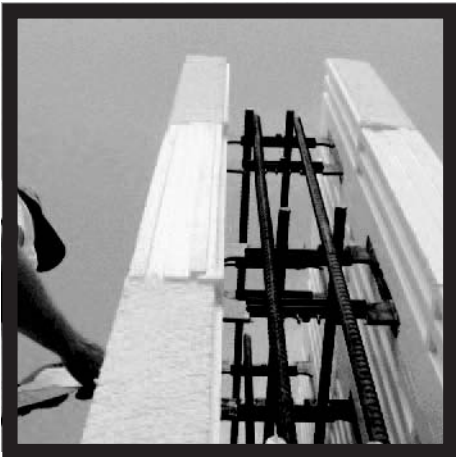

## 2.8.3 – VERTICAL REINFORCEMENT



**STEP 1:** Install vertical rebar, as required, after all courses and horizontal reinforcement have been placed.

**STEP 2:** Place vertical reinforcement under windows, if required.

**STEP 3:** Place vertical rebar on each side of every opening as required.



**STEP 4:** Cold joints between upper floor walls and lower floor walls need to be reinforced with a lap length of 40d or 24 inch (610 mm) lap length, whichever is greater (unless otherwise specified).



It is the responsibility of the installer to verify table rebar specifications to comply with local building codes and engineer specs.

## 2.8.4 – LINTELS

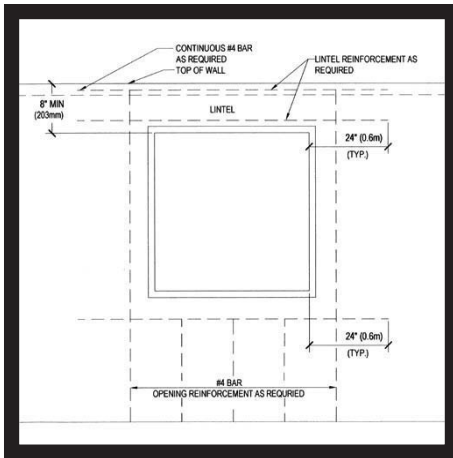

Appropriate lintel rebar should be placed in the proper sequence directly above doors and windows to carry loads over these openings.

**STEP 1:** Before placing forms across the top of door or window openings, rest the bottom lintel bar on buck material. This provides easier access to rebar for fast lintel steel installs. Check to make sure the bottom lintel steel has enough clearance. It should be 1-1/2 to 2-1/2 inches (38 to 64 mm) from buck material.

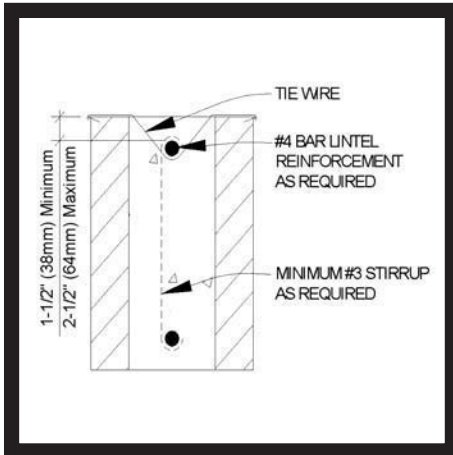

**STEP 2:** Install a course of forms across the top of the buck.

**STEP 3:** Install Form Lock across the entire length of the course. In some cases it may be require to install top lintel rebar before installing Form Lock, in order to achieve necessary concrete cover.

 For more lintel reinforcement details see Section 6.0 Engineering.

**STEP 4:** Suspend the top lintel rebar 1-1/2 to 2-1/2 inches (38 to 64 mm) below the top of the form.

**STEP 5:** Use stirrups to hang the bottom lintel rebar from the top steel, making sure the bottom rebar is 1-1/2 to 2-1/2 inches (38 to 64 mm) above the buck material.

Consistent stirrup dimensions will maximize efficiency.

The top and bottom lintel rebar must extend 24 inches (610mm) beyond both sides of window and door opening.

## 2.9 – WINDOW & DOOR BUCKS



Bucks provide attachment surfaces for windows and doors while holding back concrete from these openings during concrete placement. Mark the center and edges of openings as you place courses and cut blocks as needed.

Refer to the rough opening (R/O) dimensions for windows and doors. Provide for openings in the wall taking into consideration the thickness of the chosen buck material. See window and door manufacturer info for R/O dimensions.



Bucks can be made from vinyl or lumber. Pre-building lumber bucks saves time on the job site.

Cross bracing is required for all window and door bucks approximately 18 inches (457 mm) on center to help withstand the pressures of concrete placement.

Window and door openings within 4 feet (1.220 m) of corners require additional horizontal strapping from corner to across the opening.



Prior to placing window or door buck, confirm that bottom lintel rebar has been installed.



For more CAD drawings see Section 5.9 CAD Drawings .

## 2.9.1 – TREATED PLYWOOD BUCK



Following are several methods for building bucks. Regardless of the method chosen, pre-planning is required to optimize chosen finish materials.

**STEP 1:** Rip 3/4 inch (19 mm) treated plywood to full form width.

**STEP 2:** Rip treated 2x4 diagonally on table saw at 180° angle.

**STEP 3:** Assemble buck with appropriate fasteners with 2x4s creating a dovetail detail.

**STEP 4:** Assemble buck sides and top with access holes cut in bottom piece for placement of concrete. Two 2x4s can also be used for the bottom to allow concrete placements.

**STEP 5:** Place pre-assembled buck in opening and fasten in place with foam adhesive. The buck can also be installed in opening as separate pieces.

**STEP 6:** Install temporary cross bracing to withstand concrete pressure. Attaching screws through the buck and into closest webs can provide additional buck support.

**NOTE:** Pressure treated wood for window bucks are normally required only if the bottom of the window buck frame is located at or below ground level. Check with local building codes to determine if your area requires pressure treated window bucks.

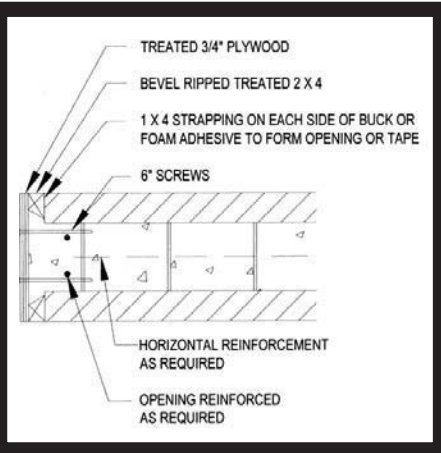

For full size CAD drawing see  
Section 5, CAD Drawings



## 2.9.2 – SOLID WOOD BUCK



**STEP 1:** Choose appropriate wood product based on the dimension of the forms:

- 4" (102mm) form: 9.5" (241mm)
- 6.25" (159mm) form: 11.75" (298mm)
- 8" (203mm) form: 13.5" (343mm)
- 10" (254mm) form: 15.5" (394mm)

**STEP 2:** Cut top piece of buck to fit the width of the opening.

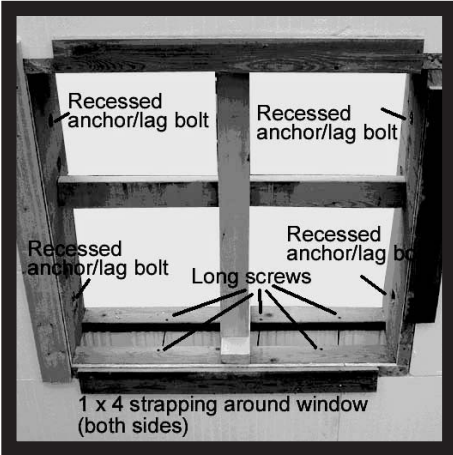

**STEP 3:** Cut sides of buck, remembering that the top piece rests on the side pieces.

**STEP 4:** Cut two 2x4s for the bottom to allow concrete placement.

**STEP 5:** Assemble buck and place in opening.

**STEP 6:** Once the buck is in place, it must be centered and secured. This can be done by attaching 1x4s to the edges of the buck, extending the edge of the 1x4 over the foam to hold the buck firmly in place. Alternately, the buck can be secured with foam adhesive and tape.

**STEP 7:** Solid wood bucks will require additional concrete anchors to create a permanent attachment to the concrete.

## 2.9.3 – VINYL BUCK SYSTEM

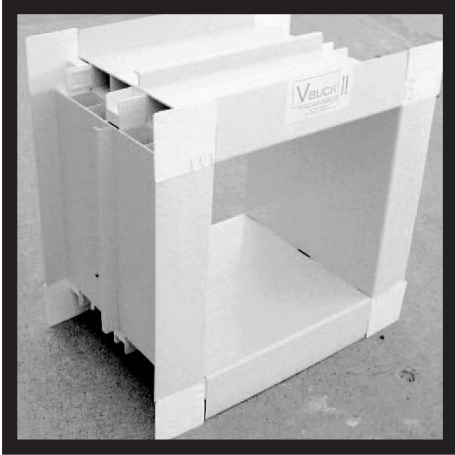

**STEP 1:** Cut the top piece of the vinyl buck to the width of the opening.

**STEP 2:** Install the top piece of vinyl buck over the forms so that it fits fully against forms. For additional support, the vinyl buck can be attached to the forms with foam adhesive after being properly cleaned with acetone.

**STEP 3:** Cut and install the bottom piece of the vinyl buck. Create appropriate holes for concrete placement and consolidation.

**STEP 4:** Cut and install the side pieces of the vinyl buck to seat against the top piece, resting on the bottom piece. Use foam adhesive for additional support if desired.

**STEP 5:** Install cross bracing as required.

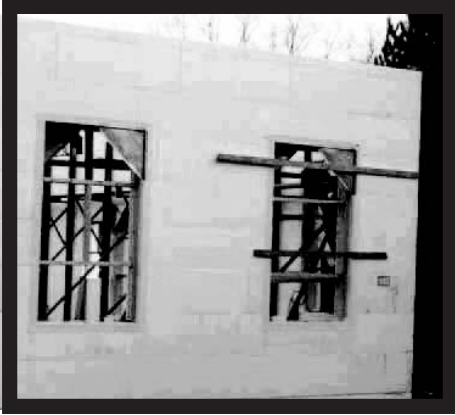

## 2.9.4 – RADIUS OPENINGS

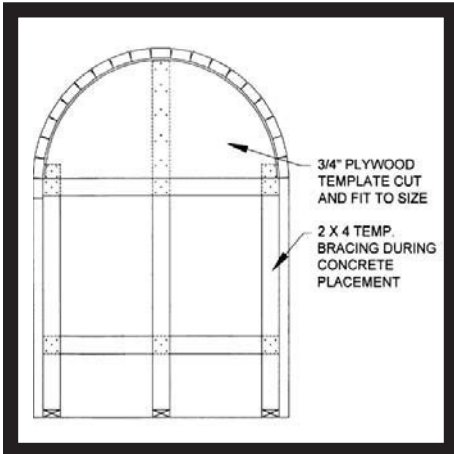

Radius windows and doors can be assembled at the site with shortened pieces of vinyl or lumber buck material.

**STEP 1:** Create the template for the radius opening with OSB or plywood that matches door or window rough opening.

**STEP 2:** Using template, draw outline of radius on wall, allowing for buck material thickness. Cut accordingly.

**STEP 3:** Cut buck material into approximately 4 inch (102 mm) widths to create radius buck.

**STEP 4:** Cut side and bottom buck pieces. Leave openings in the bottom piece for concrete placement and consolidation.

**STEP 5:** Assemble buck pieces in the opening in the following order:

- bottom
- sides
- radius top

## 2.9.4 – RADIUS OPENINGS CONTINUED

**STEP 6:** Once the buck is in place, it must be centered and secured. This can be done by attaching 1x4s to the edges of the buck, extending the edge of the 1x4 over the foam to hold the buck firmly in place. Alternately, the buck can be secured with foam adhesive and tape. Insert the radius template in opening to provide additional support.

**STEP 7:** Solid wood bucks will require additional concrete anchors to create a permanent attachment to the concrete.

## 2.9.5 – METAL JAMBS

Metal jambs are typically used in commercial applications. Many metal jamb companies will pre-bend jambs to fit LOGIX forms. Contact your local LOGIX representative for more details.

## 2.10 – ADDITIONAL FORM SUPPORT

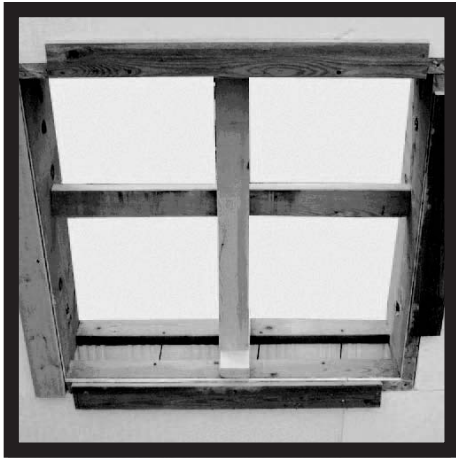

The time spent prior to concrete placement pays huge dividends in job efficiency, accuracy, and profitability. The following items should be completed.

- Horizontal wood strapping is required on both the inside and outside of the wall when:
  - The offset between joints is less than 8 inches (203 mm) between courses.
  - There are more than 3 foam bar beyond a web.
  - Vertical joints are directly on top of each other.
- Window or door openings occur less than 4 feet (1.220 m) from a corner. (Run strapping across opening to corner).
- Temporary wood straps are required around window and door openings to maintain straightness.
- Cross bracing with 2x4 supports is required inside window and door bucks to hold bucks in place and prevent sagging or bowing.
- Foam adhesive can be used on wood and plastic bucks to provide additional buck support.

I  
N  
S  
T  
A  
L  
L  
A  
T  
I  
O  
N  
G  
U  
I  
D  
E

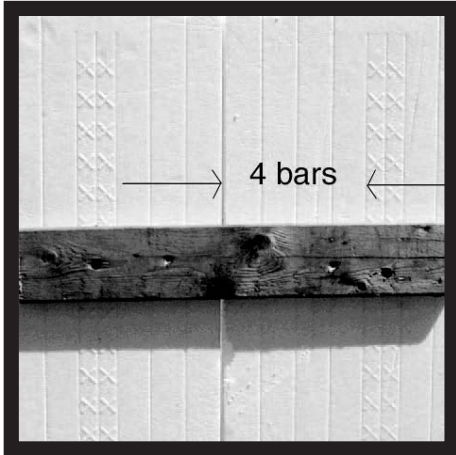

## 2.10 – ADDITIONAL FORM SUPPORT

CONTINUED



- Foam adhesive should be used to secure all Height Adjusters, and Flex Bars.
- All outside corners should be reinforced with tape or wood strapping.
- The top course should be secured with adhesive foam or zip ties.
- Sloped walls should be properly foamed and braced.
- Radius walls should be secured with foam adhesive and flexible strapping material.
- Forms in all lintels should be secured end-to-end with zip ties.
- The middle of large openings should be vertically braced to prevent tipping.
- All forms should be firmly seated to prevent settling.

INSTALLATION GUIDE

## 2.11 – WALL BRACING & ALIGNMENT SYSTEM



A bracing system provides support for the wall and acts as an alignment system to keep the walls straight and plumb during concrete placement. Typically, the wall alignment system is installed on the inner side of the LOGIX wall.

There are a number of proprietary systems available. However, each bracing unit typically consists of a vertical upright steel channel with slots for attaching screws to the LOGIX webs, a turnbuckle arm, and a scaffold bracket.



Normally, wall bracing systems are installed after placing 2 to 4 courses of LOGIX forms (depending on wind and other conditions). Attach the bracing system to the webs using #10 screws with a hex head. Screws should be snug, but not tight.

Place bracing units no more than 2 feet (0.610 m) from each corner or wall end, and every 7 feet (2.134 m) or less thereafter in accordance with OSHA/OHSA requirements. Bracing units should also be placed on either side of every door and window opening.



**STEP 1:** Attach the upright steel channel to the LOGIX webs with a screw in each course. The screws should be snug but not tight. Always place screws near the top of the slots to accommodate settling at the interlock during concrete placement.

**STEP 2:** Attach a turnbuckle arm to the upright with a bolt and then secure to the floor or ground. In light or sandy soil, additional care must be taken to secure diagonal turnbuckle.

## 2.11 – WALL BRACING & ALIGNMENT SYSTEM

CONTINUED

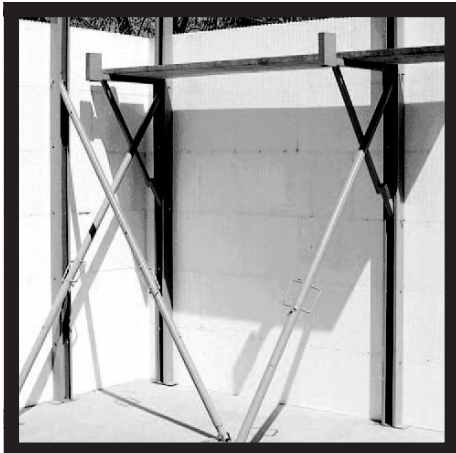

**STEP 3:** The scaffold bracket is then inserted behind the top of the turnbuckle and secured at the bottom with an additional bolt.

**STEP 4:** Place the appropriate scaffolding planks and rails according to safety regulations. For requirements on toeboard and handrail configuration, consult OSHA/OHSA.

**STEP 5:** Prior to concrete placement, make certain walls are aligned perfectly plumb, or leaning slightly inward. The wall must not lean out at all.

**STEP 6:** A string line must be used to achieve straight walls.

**STEP 7:** Before, during and after concrete placement, the diagonal turnbuckle arm is used to adjust wall straightness to stringline.

**NOTE:** For tall wall bracing and alignment see **Section 3.2, Tall Wall Bracing Systems.**



## 2.12 – FLOOR CONNECTIONS

Any type of floor system can be easily integrated with LOGIX. For any questions or assistance, please contact your local LOGIX representative.

## 2.12.1 – LEDGER WITH ANCHOR BOLTS & JOIST HANGERS

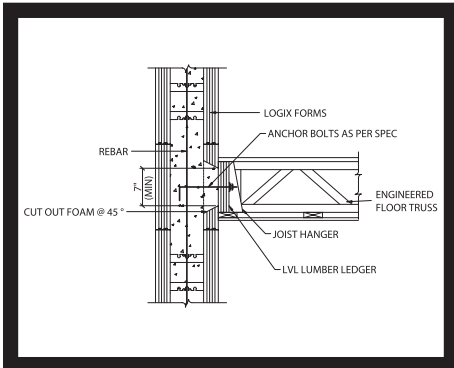
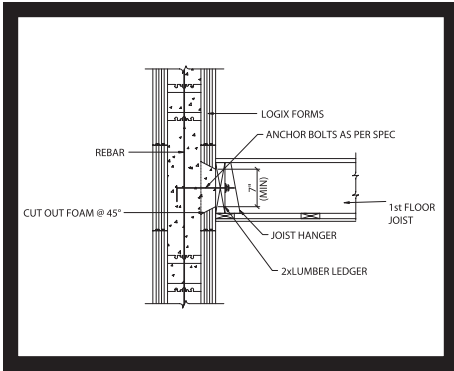

For full size CAD drawing see  
Section 5, CAD Drawings

**STEP 1:** Place LOGIX blocks to a height allowing 2 inch (51 mm) minimum coverage over embedments.

**STEP 2:** Snap chalk lines directly on forms to mark the top and bottom of the proposed rim joist.

**STEP 3:** Cut openings between chalk lines to accommodate anchor bolts. The quantity and spacing of anchor bolts will be determined by code or engineering. Make certain that cuts are flared to facilitate proper concrete placement.

**STEP 4:** Pre-cut ledger to length. Pre-drill and install anchor bolts, washers and nuts as per hole layout and local code.

**STEP 5:** Attach ledger with screws into webs to hold in place while concrete is placed. Once concrete is cured, tighten anchor bolts.

**STEP 6:** Attach joist hangers to ledger according to hanger manufacturers' specs.

## 2.12.2 – STEEL ANGLE IRON LEDGER

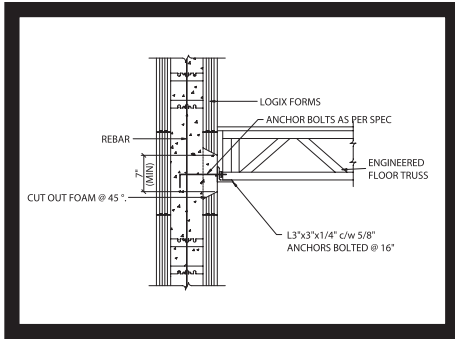

For full size CAD drawing see  
 Section 5, CAD Drawings

When floor spans become very long or concrete topping is applied to the floor, a wood ledger may not be adequate to support floor loads. In this case a steel angle iron can be used in place of a wood ledger. The angle iron can support much more weight and also eliminates the need for joist hangers, as the floor system sits right on the angle.

To install an angle iron ledger follow the steps in **Section 2.12.1**, but use pieces of plywood to temporarily hold the bolts in place. After the pour drill and bolt on the angle iron. Local steel fabricators may be able to pre-drill your angle iron.

Another alternative is to pre-fabricate an angle iron with anchor bolts or nelson studs welded directly to the angle. The entire assembly is then cast in place. This application is described below:

**STEP 1:** Cut the foam out as you would with the wooden ledger then screw on 2x4 to cover the bottom of the cutout. The 2x4 temporarily supports the angle assembly so it must be installed level.

**STEP 2:** Sit the angle assembly on top of the 2x4 and tight up against the forms.

## 2.12.2 – STEEL ANGLE IRON LEDGER

CONTINUED

**STEP 3:** Screw strapping along the top edge of the angle to keep the assembly against the form during pour.

**STEP 4:** Pour concrete and cast the assembly in place.

**STEP 5:** After some curing place floor systems on the angle and establish layout. Once layout is complete fasten the floor joist to angle with a tech screw or by ram-set. You may decide to attach a nailing surface to the bottom leg of the angle iron to nail joists to.

**NOTE:** It is code in some areas for the angle assembly to be primed.

I  
N  
S  
T  
A  
L  
L  
A  
T  
I  
O  
N  
G  
U  
I  
D  
E

## 2.12.3 – BRICK LEDGE FOR TOP & BOTTOM CHORD BEARING SYSTEMS

The LOGIX Brick Ledge form can create a load bearing surface to support floor systems, including:

- Top chord bearing trusses
- Bottom chord bearing trusses or joists
- Cast in place concrete floors
- Pre-cast concrete floors

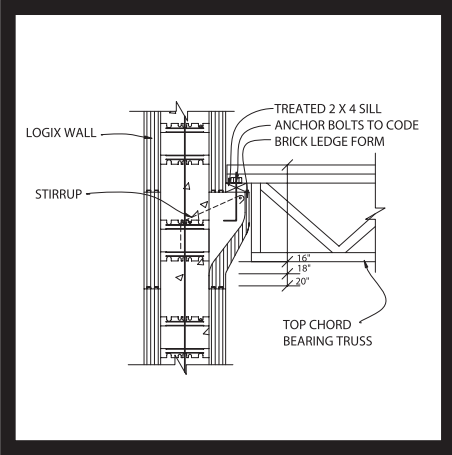

 For full size CAD drawing see Section 5, CAD Drawings

**STEP 1:** The Brick Ledge and the course above it must be foamed or otherwise secured down along the entire course to eliminate tilting or separating.

**STEP 2:** If the LOGIX block in the course above the Brick Ledge is of a smaller width than the Brick Ledge, additional form support will be required.

**STEP 3:** Install rebar in the Brick Ledge as specified. Butt joints are preferred for rebar in outer edge of Brick Ledge. Install 20 inches (508 mm) long stirrups in each Brick Ledge cavity, including the very corner.

**STEP 4:** As concrete is placed, install embedments as required.

## 2.12.4 – LEDGER WITH SIMPSON BRACKET & JOIST HANGERS

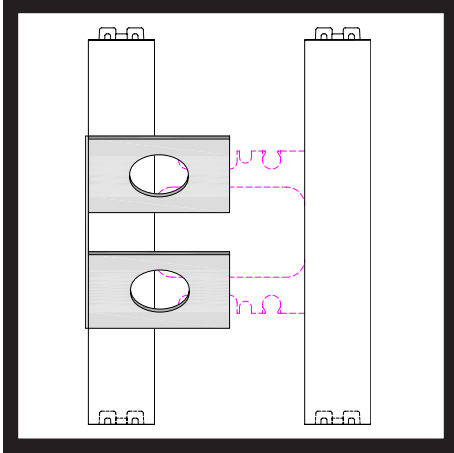
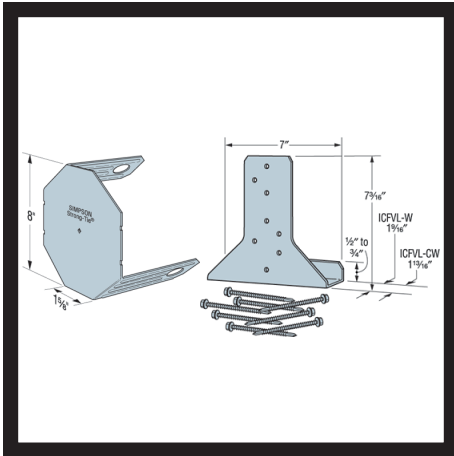

The ICFVL & ICFVL-W ledger connector system from Simpson Strong-Tie is designed for mounting steel or wood ledgers on ICF walls. The perforations in the embedded leg anchor it within the block. The exposed flange provides a structural surface for mounting either a wood or a steel ledger. The ICFVL bracket is the portion inserted into the block and embedded into the concrete. The ICFVL-W bracket is used with 1-1/2 inch (38 mm) ledger material. The ICFVL-CW bracket is used with 1-3/4 inch (44 mm) engineered wood ledgers. These brackets are installed on the ledger and attached to embedded ICFVL.

**STEP 1:** Place LOGIX blocks to a height allowing 2 inch (52 mm) minimum coverage over embedments.

**STEP 2:** Snap chalk lines directly on forms to mark the top or bottom of the proposed rim joist. For ledgers less than 10-3/8 inch (264 mm) deep, brackets should be installed to the top chalk line. For ledgers more than 10-3/8 inch (264 mm) deep, brackets should be installed to the bottom chalk line. For steel floor joists and ledgers, brackets should be centered on the proposed ledger.

**STEP 3:** Create vertical cuts to accommodate ICFVL bracket. Make sure these cuts are made directly opposite the thinned channels inside the form so that when inserted, the bracket will be exposed to the maximum amount of concrete. The quantity and spacing of brackets will be determined according to the table on [page 2-57](#).

## 2.12.4 – LEDGER WITH SIMPSON BRACKET & JOIST HANGERS CONTINUED

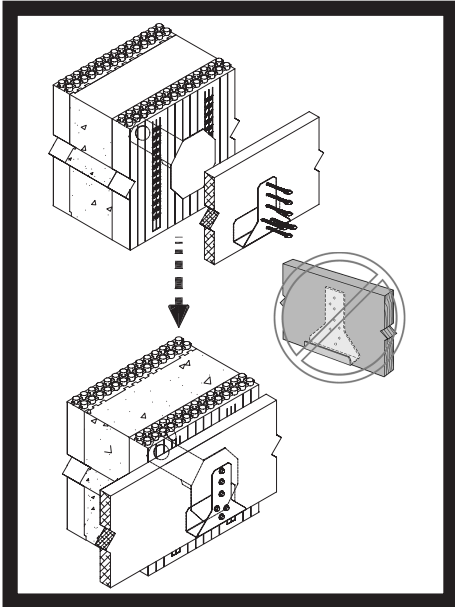

 For full size CAD drawing see Section 5, CAD Drawings

**STEP 4:** Place concrete and consolidate, ensuring brackets are fully embedded.

**STEP 5:** For wood or composite ledger, after proper concrete curing, the ICFVL-W or ICFVL-CW and appropriate ledger material can be installed using fasteners provided by Simpson Strong-Tie.

It is recommended to temporarily install ledger to chalk line, fastened to webs within 1 inch (25 mm) of the top edge of the ledger. This will make it easier to complete the installation. Slip ICFVL-W or ICFVL-CW underneath wood ledger and attach the screws as required.

For steel ledger, position ledger against ICFVL, level, and attach using appropriate fasteners as required by floor manufacturer.

**NOTE:** Industry studies show that hardened fasteners  can experience performance problems in wet environments. Accordingly, use this product in dry environments only. In addition, due to its corrosive nature, treated lumber should not be used with this product.

Use extra caution when installing the hangers on both sides of a wall. Consult your local Simpson Strongtie rep or contact Simpson Strongtie at (800) 999-5099 prior to installation.

Complete technical data is available at [www.strongtie.com](http://www.strongtie.com)

## 2.12.4 – LEDGER WITH SIMPSON BRACKET & JOIST HANGERS CONTINUED

**Simpson Strong-Tie Ledger Connector Loads & Spacings**

Ledger Type	Model No.	4" LOGIX ICF		6", 8" & 10" LOGIX ICF		4" LOGIX ICF		6", 8" & 10" LOGIX ICF		Spacing to Replace Anchor Bolts <sup>3,4,6</sup>							
		Allowable Vertical Resistance <sup>2</sup>	lbs (kN)	Allowable Vertical Resistance <sup>2</sup>	lbs (kN)	Factored Vertical Resistance	lbs (kN)	Factored Vertical Resistance	lbs (kN)	1/2" Dia. Bolts at		5/8" Dia. Bolts at					
2xD.Fir-L/SPF	ICFVL w/ ICFVL-W	1375 (6.12)	1894 (8.42)	1890 (8.41)	2630 (11.70)	12" (305mm)	4' (1220mm)	12" (305mm)	4' (1220mm)	12" (305mm)	24" (610mm)	36" (914mm)	48" (1220mm)	12" (305mm)	24" (610mm)	36" (914mm)	48" (1220mm)
		1375 (6.12)	1894 (8.42)	1890 (8.41)	2630 (11.70)	4' (1220mm)	4' (1220mm)	4' (1220mm)	4' (1220mm)	3'-9" (1143mm)	4' (1220mm)	4' (1220mm)	4' (1220mm)	3'-6" (1067mm)	4' (1220mm)	4' (1220mm)	4' (1220mm)
1 3/4" LVL	ICFVL w/ ICFVL-CW	1770 (7.87)	1894 (8.42)	2435 (10.83)	2630 (11.70)	1'-3" (381mm)	2'-3" (686mm)	1'-3" (381mm)	2'-3" (686mm)	1' (305mm)	2' (610mm)	2' (610mm)	2' (610mm)	1' (305mm)	2' (610mm)	2' (610mm)	2' (610mm)
		1770 (7.87)	1894 (8.42)	2435 (10.83)	2630 (11.70)	1' (305mm)	2' (610mm)	1' (305mm)	2' (610mm)	1' (305mm)	2' (610mm)	2' (610mm)	2' (610mm)	9" (229mm)	1'-6" (457mm)	1'-6" (457mm)	1'-6" (457mm)

Ledger Type	Model No.	4" LOGIX ICF		6", 8" & 10" LOGIX ICF		4" LOGIX ICF		6", 8" & 10" LOGIX ICF		Spacing to Replace Anchor Bolts <sup>3,4,6</sup>							
		Allowable Vertical Resistance <sup>2</sup>	lbs (kN)	Allowable Vertical Resistance <sup>2</sup>	lbs (kN)	Factored Vertical Resistance	lbs (kN)	Factored Vertical Resistance	lbs (kN)	2-5/8" Dia. Bolts at		3/4" Dia. Bolts at					
2xD.Fir-L/SPF	ICFVL w/ ICFVL-W	1375 (6.12)	1894 (8.42)	1890 (8.41)	2630 (11.70)	12" (305mm)	4' (1220mm)	12" (305mm)	4' (1220mm)	12" (305mm)	24" (610mm)	36" (914mm)	48" (1220mm)	12" (305mm)	24" (610mm)	36" (914mm)	48" (1220mm)
		1375 (6.12)	1894 (8.42)	1890 (8.41)	2630 (11.70)	1'-9" (533mm)	3'-9" (1143mm)	1'-9" (533mm)	3'-9" (1143mm)	1'-9" (533mm)	3'-9" (1143mm)	4' (1220mm)	4' (1220mm)	3'-6" (1067mm)	4' (1220mm)	4' (1220mm)	4' (1220mm)
1 3/4" LVL	ICFVL w/ ICFVL-CW	1770 (7.87)	1894 (8.42)	2435 (10.83)	2630 (11.70)	--	--	1'-9" (533mm)	3'-6" (914mm)	--	--	--	--	--	--	--	--
		1770 (7.87)	1894 (8.42)	2435 (10.83)	2630 (11.70)	--	--	--	--	--	--	--	--	--	--	--	--

**Allowable lateral load = 1905lbs (8.47kN) (Applicable to all form sizes).**

1kN = 224.8lbs = 102Kg

- Minimum steel ledger specification is Fy=33ksi (230MPa) and Fu=45ksi (310MPa) in accordance with CSA S136-94.
- No load duration increase is allowed.
- Spacing is based on vertical load only.
- For steel ledger, spacing is based on a combination of ledger gauge & anchor bolt diameter. Spacing is closer for a 14 gauge ledger in order to achieve the equivalent bolt/ledger capacity.
- Minimum concrete compressive strength,  $f_c$ , is 2500psi (17.25MPa).
- The designer may specify different spacing based on the load requirements.
- For more information contact Simpson Strongtie at [www.simpsonstrongtie.com](http://www.simpsonstrongtie.com)

**Note:** Industry studies show that hardened fasteners can experience performance problems in wet environments. Accordingly, use this product in dry environments only. In addition, due to its corrosive nature, treated lumber should not be used with Simpson Strongties.

## 2.12.5 – McMILLAN JOIST HANGERS

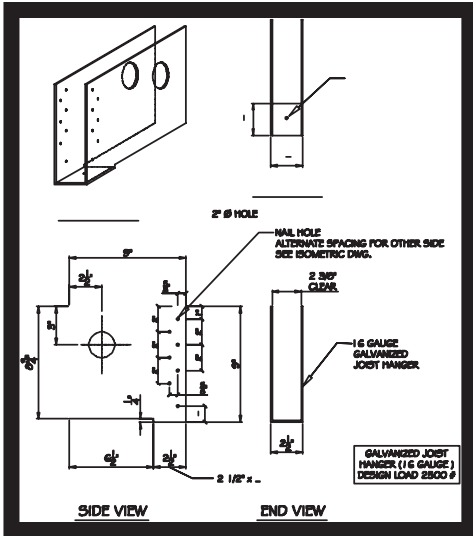

The McMillan Joist Hanger is designed to support wood floor joists to ICF walls. The perforations in the embedded leg anchor it within the block. The exposed end provides a 2.5 inch x 2.5 inch (63.5 mm x 63.5 mm) structural bearing surface for mounting wood joists with optional sizes of 1-9/16 inch (40 mm), 2-9/16 inch (65 mm) and 3-5/8 inch (92mm).

**STEP 1:** Determine height of floor and subtract height of floor joist.

**STEP 2:** Level marks with a transit or measuring tape and chalk line.

**STEP 3:** Screw a 2x4 ledger at chalk line to set joist hanger on.

**STEP 4:** Place joist hangers to floor joist layout spacing.

**STEP 5:** Cut two vertical slotted holes with a keyhole saw, slide joist hanger into ICF block, fasten if necessary.

**STEP 6:** Ensure the joist hangers are sitting straight after the placement of concrete.

**NOTE:** For more information contact 1-250-318-0062.

INSTALLATION GUIDE

For full size CAD drawing see Section 5, CAD Drawings



[www.logixicf.com](http://www.logixicf.com)

Good. Solid. Green.™

2-60



## 2.12.6 – TRANSITION LEDGE

A transition ledge is commonly used when the LOGIX walls will be continuing up to the roofline.

The ledge created when transitioning from a wider to a narrower wall can provide a suitable bearing surface for many types of floor systems.

For additional bearing support LOGIX Taper Top and Transition forms can be used as the top course when transitioning from a 6.25 inch (159 mm) to 4 inch (102 mm) LOGIX wall.

## 2.12.6.1 – TRANSITION LEDGE WITH TAPER TOP FORMS

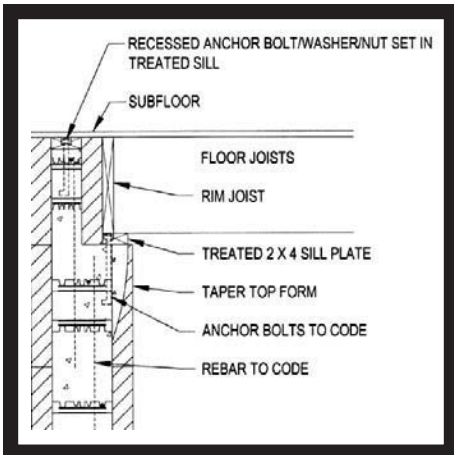

LOGIX 6.25 inch (159 mm) Taper Top forms can be used as the top course when transitioning to a 4 inch (102 mm) wall. Alternately, 6.25 inch (159 mm) Standard forms and corner forms can be hand cut to create Taper Top forms.

LOGIX 8 inch (203 mm) Taper Top forms can be used as the top course when transitioning to 4 inch (102 mm) or a 6.25 inch (159 mm) wall.

When hand cutting Taper Top forms, be careful not to drop foam scraps into the wall cavity.

INSTALLATION GUIDE

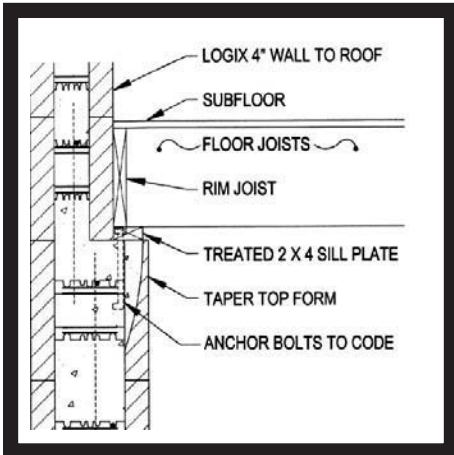

**STEP 1:** Set Taper Top form as the top course of the lower wall.

**STEP 2:** Using short lengths of #4 (10M) rebar, provide a bearing support for the unsupported edge of the upper (narrower) form.

**STEP 3:** Install upper form, using foam adhesive to prevent lifting or tipping at connection.

**STEP 4:** 1x4 lumber can be attached vertically to the outside of the forms to assist in wall alignment.

**STEP 5:** Right after concrete placement, trowel off the ledge while checking for level. Insert embedments as required.

## 2.12.6.2 – TRANSITION LEDGE WITH LOGIX TRANSITION FORMS



**Figure 1a: LOGIX Transition Block**

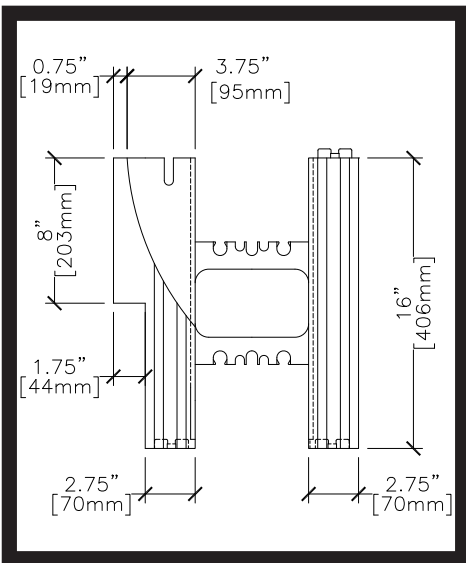

**Figure 1b: LOGIX Transition Block End View**

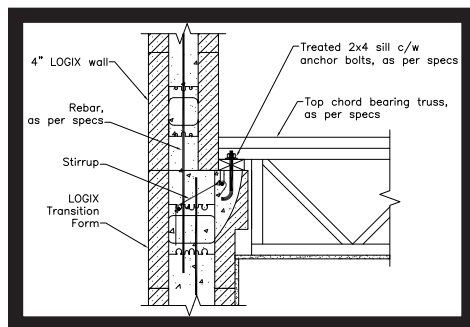

LOGIX Transition forms provide more bearing support than the LOGIX Taper Top forms. The Transition forms are available in straight units. See **Figure 1a & 1b**.

When transitioning from a thicker wall to a thinner wall (i.e., 6.25 inch (159 mm) to 4 inch (102 mm) wall) the LOGIX Transition form can provide additional bearing support for heavier loaded floor systems.

The corbel ledge of the Transition forms can support a load of up to 1300lb/ft (19kN/m) providing a total bearing seat length of 3.75 inch (95 mm).

With the corbel extending 1.75 inches (44 mm) from the face of the wall, it also adds an aesthetic crown moulding-like feature when used as the top course of an interior wall.

Creating corner forms are easily installed, and is very similar to creating corner forms with LOGIX Brick Ledge forms (see **Section 2.7.4**).

For bracing installation, refer to **Section 3**. If the bracing is placed on the corbel side of the forms, the upright vertical channel should terminate just under the corbel of the Transition form.

## 2.12.6.3 – TRANSITION LEDGE WITH CORNER BLOCKS

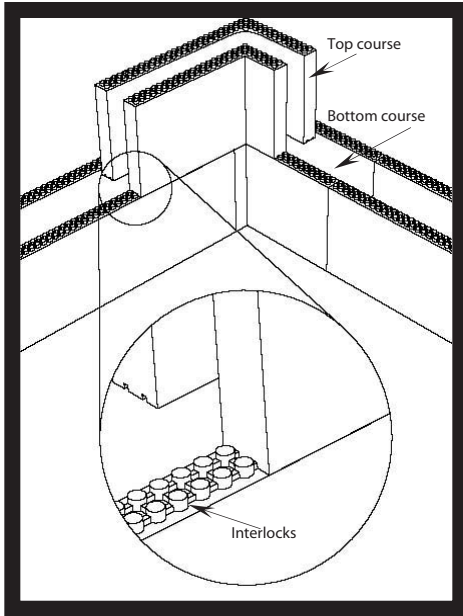

Figure 1a. Proper alignment of top course to bottom course. Interlock aligns with underside of top course.

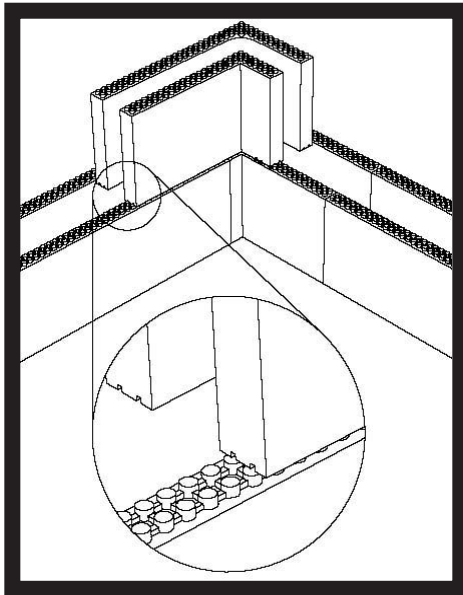

Figure 1b. Improper alignment of top course to bottom course. Interlock does not align with underside of top course.

Transitioning from a wider block to a narrower block is commonly used in cases where a thinner wall becomes more economical (i.e., below grade wall to above grade wall), or to create a ledge that can support a floor or roof system, or finishes such as brick veneer.

When transitioning at corner locations using corner blocks, you might find that the interlocking knobs on the top side of the wider bottom block (bottom course) do not interlock or align with the underside of the top narrower block (top course). As a result, the top course will not sit or snap into its proper position (see **Figure 1a & 1b**).

This occurs in transitions at corner location only, and is easily resolved by following a few simple steps outlined below.

## 2.12.6.3 – TRANSITION LEDGE WITH CORNER BLOCKS CONTINUED

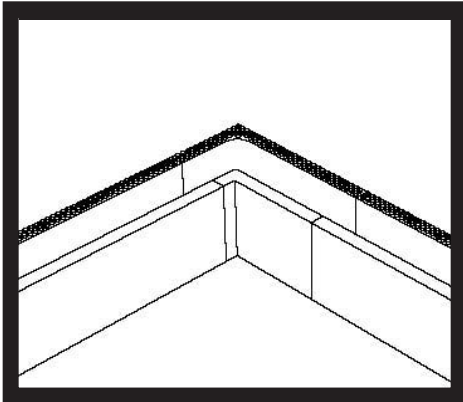

Step 1

**STEP 1:** Cut the interlocks off the wider corner blocks (it may be necessary to cut the interlocks off the rest of the blocks on the bottom course to ensure the top course can be placed flush on top of the previous course).

As an alternative, Taper Top blocks for the bottom course can be used. The Taper Tops provide more flexibility since they can be adjusted to ensure the interlocks align with the top course.

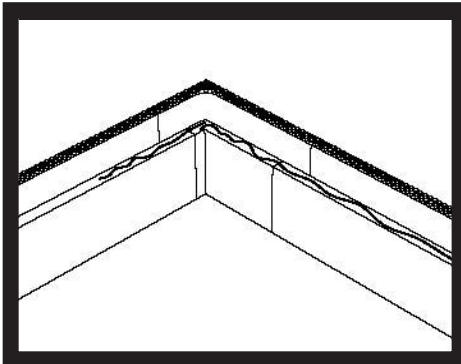

Step 2

**STEP 2:** Apply foam adhesive prior to installing the top course.

**STEP 3:** Install the top course beginning with the corner block and continuing around the building perimeter.

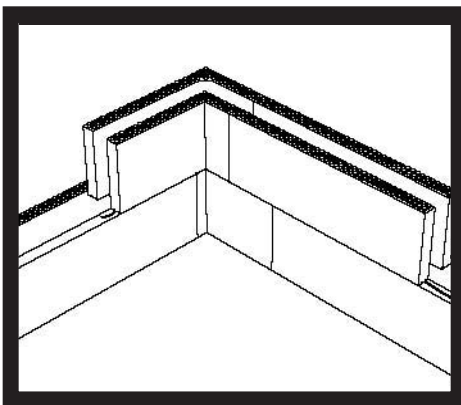

Step 3

## 2.12.7 – TAPER TOP WITH SILL PLATE

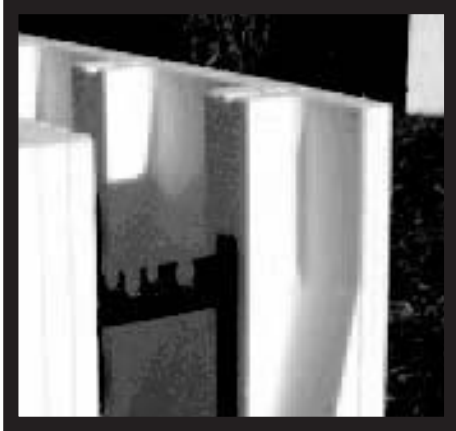

The Taper Top form creates a greater bearing surface at the top of LOGIX walls.

**STEP 1:** Taper Top forms need to be foamed down or otherwise secured to the course below.

**STEP 2:** Trowel concrete flush with top of forms, or inset as required. Be sure to check for level.

**STEP 3:** Insert embedments as required.

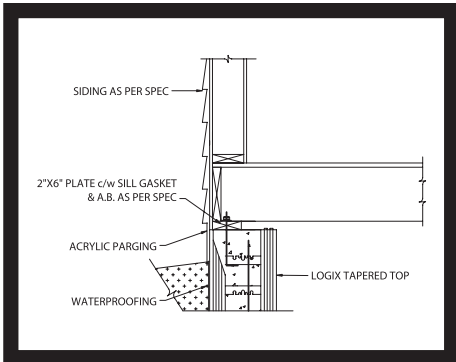

I  
N  
S  
T  
A  
L  
L  
A  
T  
I  
O  
N  
G  
U  
I  
D  
E

 For full size CAD drawing see Section 5, CAD Drawings

## 2.12.8 – CONCRETE FLOOR SYSTEMS



Building with LOGIX will allow you to explore many concrete floor system options. Our walls are stronger and can support added weight that wood or steel frame buildings may not. Concrete floor systems are very popular in multi-residential buildings where the transmission of sound and fire are a concern. They are also growing in popularity in single-family residential applications.



## 2.12.8.1 – PRECAST CONCRETE FLOORS

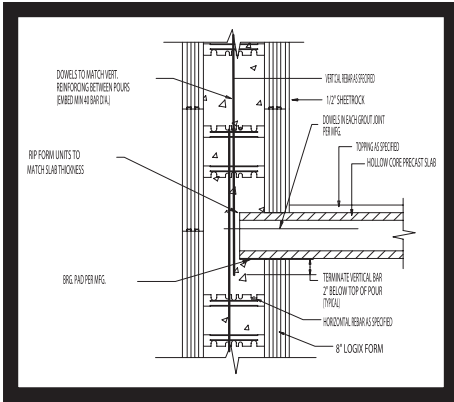

Pre-cast floor systems are poured at the factory and shipped to site then craned in place. They are usually tensioned with steel cables cast in the concrete to provide maximum strength. Pre-cast floor are fast and can have very long clear spans.

Typically the LOGIX wall is constructed to the desired height and the pre-cast planks sit directly on the cured concrete. The planks, typically 4 feet (1.220 m) wide, are craned in place and the grooves between planks are grouted together. A 2 inch (52 mm) topping is poured over the deck to provide a smooth and level finish.

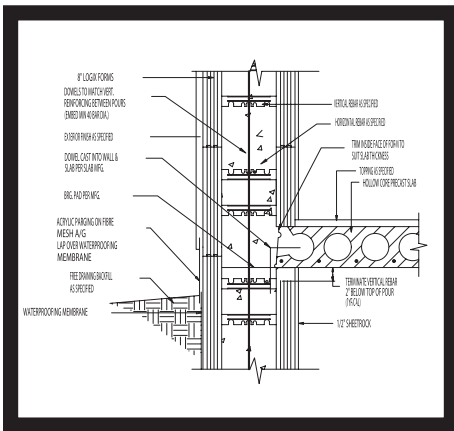

The reinforcing of the wall is tied in to the grouted grooves to secure the floor in place. The vertical reinforcing of the wall is extended past the planks to secure future levels of LOGIX.

 For full size CAD drawing see Section 5, CAD Drawings

See floor manufacturer for specific installation requirements and details.

INSTALLATION GUIDE

## 2.12.8.2 – HAMBRO FLOOR SYSTEM

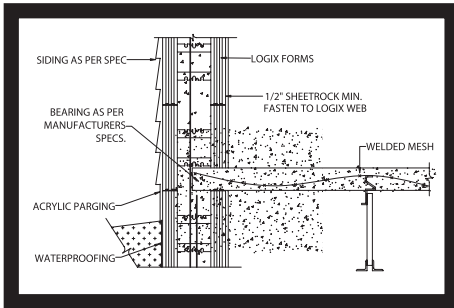
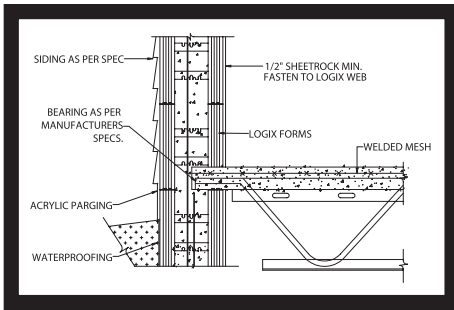

For full size CAD drawing see  
Section 5, CAD Drawings

The Hambro floor system is a proprietary composite floor system that combines open web steel joists and a 2.5"-5" (64mm - 127mm) floor slab. The joists are spaced 4'-1" (1.225m) O.C. and held apart with locking bars. Then temporary plywood forms are placed between the joists and the concrete deck is poured. After sufficient cure the plywood forms are removed. Hambro is a fast and efficient concrete floor system and can span upwards of 25 feet (7.620 m).

The open joist design makes for easy mechanical and utility installation.

See Hambro for more details: [www.hambrosystems.com](http://www.hambrosystems.com)

## 2.12.8.3 – STEEL COMPOSITE FLOOR SYSTEM





Composite floors are a combination of steel and concrete that is bonded together to create a very strong floor. The steel composite decking is a corrugated steel pan that has deformations that bond securely with the concrete. The steel deck is the formwork for the pour and then acts as reinforcement in the concrete. These systems are quick to install and are comparatively thin, resulting in more headroom in the finished.

It may be necessary to temporarily support the pan until the concrete has sufficiently cured.

For more info and design consult your floor manufacturer and your local design engineer.

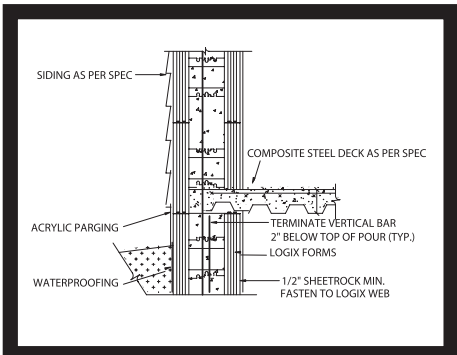
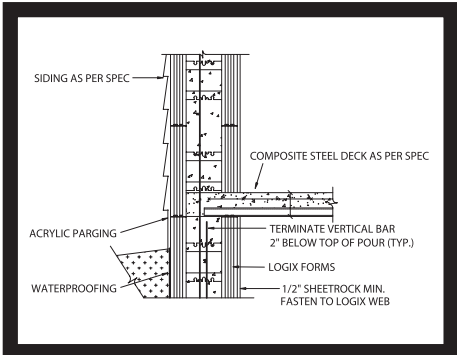
INSTALLATION GUIDE



 For full size CAD drawing see Section 5, CAD Drawings

[www.logixicf.com](http://www.logixicf.com)

Good. Solid. Green.™

2-70



## 2.13 – ROOF CONNECTIONS

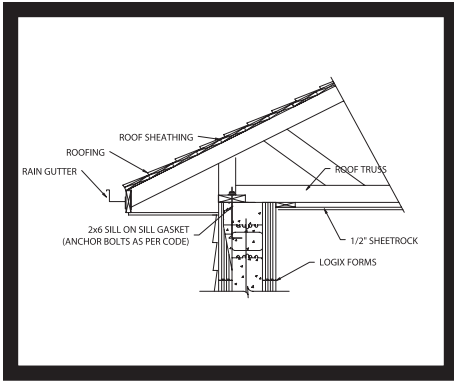



Roof connections can be attached to the LOGIX wall in a variety of ways. Several factors can affect which method to use such as area of the country and wind conditions.

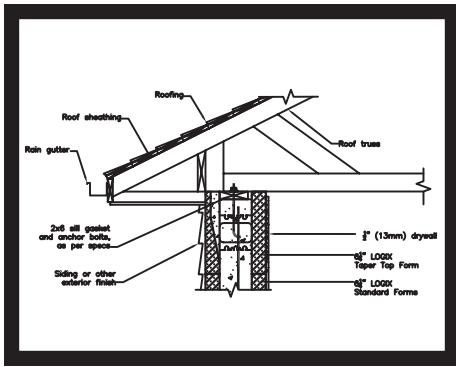

For full size CAD drawing see  
Section 5, CAD Drawings

## 2.13.1 – INSET SILL PLATE



For full size CAD drawing see  
 Section 5, CAD Drawings

This method of sill plate attachment is one of the most energy efficient. The LOGIX foam on each side provides an excellent thermal barrier.

**STEP 1:** Trowel the concrete out to a level below the top of the form equal to the depth of the sill plate. Use a site built wood trowel. Be sure to cut the trowel board to the full width of the concrete core.

**STEP 2:** Install embedments as required.

**NOTE:** For ease of concrete flow it is recommended to use either LOGIX Taper Top or Double Taper Top for the top course.

## 2.13.2 – TOP MOUNTED SILL PLATE

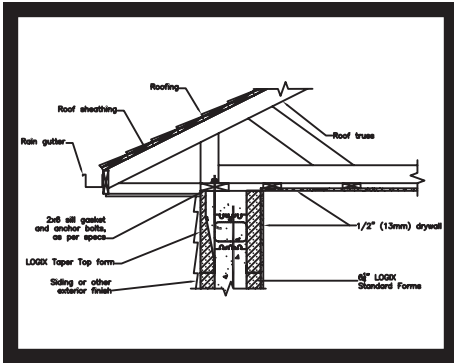

For full size CAD drawing see  
Section 5, CAD Drawings

This method is typically used when additional wall height is required.

**STEP 1:** Trowel concrete flush with top of form and recheck for level.

**STEP 2:** Install embedments as required.

**NOTE:** For ease of concrete flow it is recommended to use either LOGIX Taper Top or Double Taper Top for the top course.

## 2.14 – SERVICE PENETRATIONS



Identify and size all service and utility penetrations. Install all appropriate and properly sized sleeves where required, remembering that lightweight sleeves can be crushed during concrete placement.

List of possible service penetrations

- Dryer vent
- Water heater vent
- Water
- Sewer
- Electrical main service
- Gas line
- A/C line
- Furnace vent
- Air Exchange/HRV
- Central vacuum
- Ducting
- Bathroom vent
- Kitchen appliance venting
- Fireplace rough opening and vent
- Pet door



## 2.15 – CONCRETE PLACEMENT

### PRE-PLACEMENT CHECKLIST

DATE:

FOREMAN:

JOB:

Prior to placing concrete in LOGIX insulated concrete forms, be certain to mark off each item on the checklist provided in this section.

- 1. String line in place around the top of entire perimeter?
- 2. Walls straight and plumb (not leaning out)?
- 3. Top course foamed or tied down and zip tied end to end to maintain dimensions?
- 4. Additional form support on all corners?
- 5. Have Tee-walls been foamed and supported?
- 6. Alignment - screw in every course?
- 7. Scaffold planking properly secured?
- 8. All handrails and toe boards installed?
- 9. All bucks cross braced?
- 10. All bucks secured to wall?
- 11. All buck concrete anchors installed?
- 12. All horizontal and vertical rebar in place?
- 13. All lintel reinforcing in place?
- 14. All penetrations installed?
- 15. All beam pockets in place?
- 16. All floor embedments installed?
- 17. Are anchor bolts and hold-downs on site?
- 18. Has cavity of wall been checked, and foreign material removed?
- 19. Plywood, screw gun, and saw on site?
- 20. Interlock protected by tape, LOGIX Flex Bars or other covering?
- 21. Proper concrete mix and slump ordered?
- 22. Concrete vibrator on site?
- 23. Pump equipped with double-90 or reducer available?

## 2.15 – CONCRETE PLACEMENT CONTINUED

The most important stage of a successful LOGIX project is the concrete placement. Extra workers at this stage are important - be certain to have enough on hand during the pour to safely handle placement, consolidation, alignment, embedments, and cleanup.

Ensure straight walls by placing a string line at the top course set off from the wall using 3/4 inch (19 mm) pieces of wood placed in the corners. Check for straightness by running another 3/4" inch (19 mm) piece of wood between the string and wall. Adjust the turnbuckles as necessary to keep the wall straight during concrete placement. Walls must be perfectly straight or leaning in slightly.

During concrete placement, watch the string lines to monitor the wall for straight and plumb.

Suggested minimum compressive concrete strength of 2,900 psi (20MPa) at 28 days. For seismic areas mix design should be confirmed with local codes or by an engineer.

The following maximum aggregate sizes are recommended for use in LOGIX walls:

	Form Cavity Size, in. (mm)				
	4 (102)	6.25 (159)	8 (203)	10 (254)	12* (305)
Max. Aggregate Size, in. (mm)	3/8 (9.5)	3/8 (9.5)	3/4 (19)	3/4 (19)	3/4 (19)

## 2.15 – CONCRETE PLACEMENT CONTINUED



Concrete slump should be 5 inch (127 mm) to 6 inches (152mm) for best results.

A pump truck with double 90° elbows or a reducer attached to a rubber extension works best to control the rate of concrete flow.

When placing concrete in 4 inch (102 mm) forms, it is recommended that the pump truck be fitted with a 3 inch (76 mm) flexible hose end.



Other methods of placement include conveyor truck, crane and bucket, and directly off the ready mix truck.

Lift height is determined by many factors, such as air temperature, concrete temperature, slump, etc. In general, lift heights should not exceed 4ft (1.220 m).

Example: on a 60° F (15° C) day with a 6 inch (152 mm) slump, the lift height should be approximately 3 feet (0.914 m). Below is a guide for a lift heights according to varying temperatures and with a 6 inch (152 mm) slump.

Consult local ready mix companies for appropriate concrete mix design.

When placing concrete below freezing or at temperatures above 100° F (38° C), it's important to protect all exposed concrete with insulation.

## 2.15 – CONCRETE PLACEMENT CONTINUED

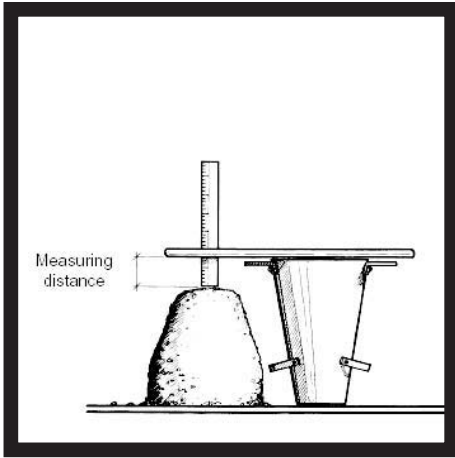

Proper concrete consolidation is critical in obtaining a structurally solid wall.

Use an internal vibrator with a head size of 3/4 inch (19 mm) to 1 inch (25mm) and maximum 1 hp motor. Do not use a vibrator with a head larger than 1 inch (25 mm).

Appropriate internal vibration assures the strongest walls possible and is especially important for below grade application where the greatest loads occur.

The rule of thumb for internal vibration is fast in and slow out, always moving, with a withdrawal rate of approximately 3 inch (76 mm) per second.



Temperature	Lift Height (6" slump)
40°F (4°C)	2'-2.5" (670mm)
50°F (10°C)	2'-9" (840mm)
60°F (15°C)	3'-10.25" (920mm)
70°F (21°C)	3'-10.25" (1170mm)
80°F (27°C)	4'-4.75" (1340mm)
90°F (32°C)	4'-11.5" (1510mm)

## 2.15 – CONCRETE PLACEMENT CONTINUED

**STEP 1:** Complete the pre-placement checklist.

**STEP 2:** Begin concrete placement under openings, filling those areas and consolidating.

**STEP 3:** Beginning no closer than 3 feet (0.914 m) from a corner, start filling the wall from the top, allowing the concrete to flow gently toward the corner. Then fill in that corner from the opposite side using the same technique.

**STEP 4:** Continue placing concrete around entire wall in appropriately sized lifts, using the same technique at each corner to minimize fluid pressure.

**STEP 5:** As the concrete is being placed, consolidation is taking place to remove air and voids to ensure structural integrity.

**STEP 6:** As the concrete is being placed, continually check wall alignment using string line. Adjust the wall accordingly to maintain straight and plumb using the adjustable turnbuckle.

**STEP 7:** Return to starting location and begin the next lift. Follow all the techniques established above.

## 2.15 – CONCRETE PLACEMENT CONTINUED

### POST-PLACEMENT CHECKLIST

DATE:

FOREMAN:

JOB:

After placing concrete in LOGIX insulated concrete forms, be certain to mark off each item on the checklist provided in this section.

- \_\_\_ 1. Has consolidation been completed?
- \_\_\_ 2. Are walls straightened to string line?
- \_\_\_ 3. In extreme temperatures, has exposed concrete been protected?
- \_\_\_ 4. Have all anchors and embeds been installed?
- \_\_\_ 5. Has spilled concrete been disposed of?
- \_\_\_ 6. Has final check for straight and plumb been done?

## 2.16 – ELECTRICAL INSTALLATIONS



Electrical and plumbing installation are typically performed after concrete placement.

The exception to this rule is the placement of conduit that penetrates the wall, which must be performed before concrete placement.

Installing electrical wiring and boxes is accomplished by creating channels in the EPS foam. When installed in LOGIX walls directly against the concrete, electrical boxes will extend 1/2 inch (13 mm) beyond the foam to match the thickness of 1/2 inch (13 mm) sheetrock.



Various tools can be used to create the channels and spaces for wiring and boxes:

- Electrical chainsaw with an adjustable roller depth stop
- Hot knife
- Circular saw with a masonry blade



Make the wiring channels narrow so there will be a friction fit with the wiring. The wiring needs to remain embedded well into the foam to meet local electrical codes. Foam adhesive can be spot-applied into the channel to help hold the wiring in place.

## 2.17 – PLUMBING INSTALLATIONS



In most cases, buildings are designed so plumbing pipes are not carried through the LOGIX walls, except for utility entry and exit points.

However, in some cases it may be required to embed pipe in the EPS. For example, a kitchen vent tube may need to be installed vertically in the EPS foam. Pipes embedded in the foam cannot exceed 1-1/2 inch (38 mm) in diameter. Fittings embedded in the foam cannot exceed 2-1/2 inch (64 mm) diameter.

An external faucet will require the installation of a hose sleeve through the wall prior to concrete placement. This will permit replacement of the faucet or pipe should it ever be necessary.

If connecting to existing sewer lines, establish the location of the required opening and ensure clearances, since this is difficult to change.

## 2.18 – INTERIOR & EXTERIOR FINISHES

### 2.18.1 – VAPOR & AIR BARRIERS

The LOGIX wall assembly has no need for an additional vapor barrier, the solid concrete core covered with the low permeance EPS (Type II) foam insulation on the inside wall face keeps water vapor from penetrating the wall.

The fact that the inner face of EPS foam maintains a similar temperature as the inside air of the building and that a LOGIX wall has no cavity means that no condensation can occur in a LOGIX wall assembly.

The LOGIX wall assembly has no need for an air barrier (building wrap) layer as the solid concrete core and low permeance EPS (Type II) foam insulation on the outside wall face keeps air and moisture from penetrating the wall.

## 2.18.2 – INTERIOR DRYWALL

Drywall should be installed in the same manner on a LOGIX wall as on a stud wall, with the following time-saving exceptions:

- All webs (studs) are on 8 inch (203 mm) centers from floor to ceiling for easy attachment of any type of interior wall finish.
- The butt joints of the sheetrock do not need to fall on webs (studs) as the foam provides solid backing wherever the joints fall.
- A foam-compatible adhesive can be used to effectively fasten the sheetrock to the LOGIX wall along with screws. Always make sure to verify the local code for types and spacing for sheetrock fasteners. Typically, adhesive alone is not allowed as a fastener of sheetrock, but again check with local building codes.

Many local building codes require the application of 1/2 inch (13 mm) drywall or other suitable thermal barrier in any living space even though the EPS foam has a fire retardant component. Always verify local building code requirements.

## 2.18.2 – INTERIOR DRYWALL CONTINUED

Non-habitable spaces such as crawl spaces, attics, and other types of hidden areas typically do not require a thermal barrier (drywall).

Embedded furring tabs are fixed at each corner of the LOGIX 90° corner forms for solid sheetrock fastening at all corners.

## 2.18.3 – EXTERIOR SIDING



Siding material of some kind must be installed over the EPS foam to protect it from the UV rays of the sun. Foam left exposed to the sun will degrade on the exposed surface by slowly breaking and getting “dusty”.

Metal and vinyl siding can be installed directly over the top of the EPS.

Although air guns can be used, LOGIX recommends the use of screw guns when attaching exterior siding. Always follow manufacturer’s recommendations and local codes to determine the size and spacing of fasteners for all siding products.

Any type of siding that is used on a typical wood-framed building can be used on a LOGIX building.

The siding channel stock around doors and windows can be fastened to whatever type of buck material was chosen, in a similar fashion as wood framed building.

A plastic corner web is embedded in all corners as a fastening surface. See **Section 5.1.6 & 5.1.7** for further details on the plastic corner web.

INSTALLATION GUIDE

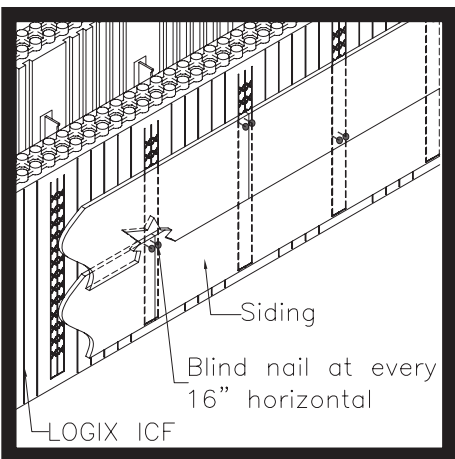
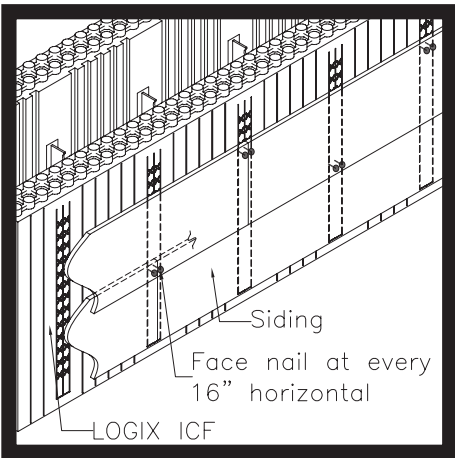

## 2.18.4 – STEEL PANEL SIDING

Steel panel siding can be applied vertically to a LOGIX wall when the style of the panel matches the LOGIX web 8 inch (203 mm) increments for fastening purposes.

When a panel siding is chosen that doesn't fit with 8 inch (203 mm) increment for fastening, two different methods are available:

### **METHOD 1:**

A 1/2 inch (13 mm) or 3/4 inch (19 mm) strip of wood can be attached horizontally to the webs in the wall to provide the manufacturer's specified fastener spacing.

### **METHOD 2:**

The panels can be installed horizontally, by fastening directly into the webs.

**NOTE:** Although air guns can be used, LOGIX recommends the use of screw guns when attaching exterior siding. Always follow manufacturer's recommendations and local codes to determine the size and spacing of fasteners for all siding products.

## 2.18.5 – WOOD SIDING

Any wood siding can be attached to the LOGIX wall in the same manner as to a traditional framed building. The spacing of the web studs on 8 inch (203 mm) centers allows for industry standard spacing of fasteners. Typically, screws are used for attaching wood siding or even half-log siding to the LOGIX wall.

Although air guns can be used, LOGIX recommends a screw gun with screws in clips (Quik Drive). This is usually the fastest method for applying wood siding. Always follow manufacturer's recommendations and local codes to determine the size and spacing of fasteners for all siding products.

A good practice for installing wood siding on a wall, is to apply the siding over vertical 1 inch x 2 inch (25 mm x 51 mm) wood nailing strips with a screen at the bottom. The screen keeps insects out while the space allows air to circulate behind the siding. The air circulation helps equalize the moisture content in the wood siding, which makes for much more dimensionally stable siding and longer lasting application.

## 2.18.6 – EIFS

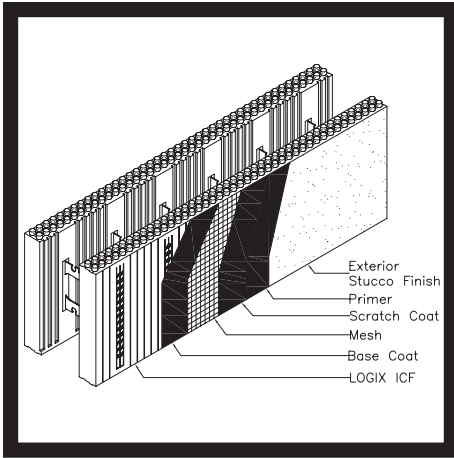

There are now acrylic-based stucco products available that are more flexible and easier to work with than traditional cement-based stucco. Collectively these products are known as EIFS (Exterior Insulation Finish Systems) and almost always require an EPS substrate.

Because LOGIX blocks are made with EPS, they are a natural fit for EIFS finishes. In addition, the webs in LOGIX blocks are embedded 1/2 inch (13 mm) deep in the EPS foam to comply with EIFS manufacturer requirements.

It is important to follow the EIFS manufacturer's application procedures.

## 2.18.7 – TRADITIONAL STUCCO (CEMENT-BASED)

LOGIX walls will accept traditional cement-based stucco product. Although air guns can be used, LOGIX recommends a screw gun when attaching the wire lath mesh to LOGIX walls. Use screws with a wide head or screws along with washers to best hold the mesh in place.

Consult local building codes for vertical and horizontal fastener placement requirements. The center-to-center fastener spacing requirements for nails and staples must be followed for screws as well. Again, check with local codes for all specific requirements relating to the application of stucco over EPS insulation.

## 2.18.8 – CEMENT COMPOSITE SIDING

Recently the new cement fiber siding products have gained popularity. This type of siding can usually be fastened directly to the LOGIX webs. Although air guns can be used, LOGIX recommends a screw gun to fasten flat-headed exterior screws at 16 inch (406 mm) centers. The screws pull the siding in tight and hold the siding securely in place. Some manufacturers may require the siding to be strapped out to allow air space behind. Vertical or shake patterns will require strapping for fastening. Always follow manufacturer's recommendations and local codes to determine the size and spacing of fasteners for all siding products.

Check with your siding manufacturer for specific requirements.

## 2.18.9 – BRICK VENEER

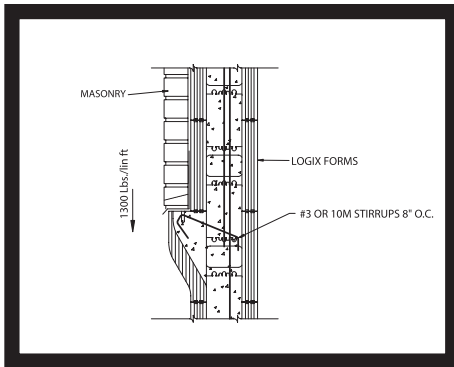

The LOGIX Brick Ledge form units are used to support a brick veneer as the exterior finish material. The Brick Ledge forms are simply placed at a level where the brick is desired to begin. The design of the form creates a reinforced concrete ledge.

With standard reinforcing, the Brick Ledge can bear up to 1300lb/ft (19kN/m) of wall.

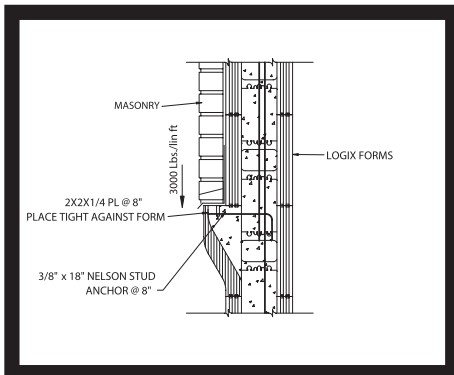

With site-specific engineering, up to 3000lb/ft (44kN/m) of wall is attainable.

To install Brick Ledge form units, follow the instructions on **Section 2.7.4** of the guide. When reinforcing steel and concrete are in place within the wall, brick is laid on the ledge and tied back to the webs with brick ties as specified.



For full size CAD drawing see  
Section 5, CAD Drawings

## 2.18.10 – BELOW GRADE WATERPROOFING, DAMPPROOFING & PARGING

There are many methods available to protect the “below grade” and the “just above grade” areas of the exterior of your building.

Dampproofing is used on concrete or masonry surfaces to repel water in above grade walls. The 2.75 inch (70 mm) and thicker foam panels of the LOGIX insulated concrete forms acts as dampproofing, therefore, no additional dampproofing treatment is required.

**NOTE:** Although dampproofing above grade walls is not typically required, check with local building codes for dampproofing requirements.

## 2.18.10.1 – BELOW GRADE WATERPROOFING



LOGIX recommends a rubberized “peel and stick” waterproofing membrane. The membrane is applied vertically to the wall from grade level down to and overlapping the top of the footing. It is recommended to use protection board (1/2 inch EPS or EXP foam sheets or similar) to prevent damage to the waterproofing membrane during backfilling.

Free flow drainage material with a maximum fluid density of 30 pcf (480 kg/m<sup>3</sup>) is recommended, i.e., sand or sand-gravel mix.

**NOTE:** Membrane should be installed within one week prior to backfill being placed. Sunlight and high temperatures may cause the membrane to begin to “sag” which may cause wrinkles in the material which may result in tears or punctures during the placement of the backfill material. Should you choose to use one of the many other types of waterproofing available be sure to follow the manufacturer’s recommended installation procedures.

**STEP 1:** Prep the wall and footing area to be covered by removing dirt and debris.

**STEP 2:** Snap chalk lines for the “grade” line.

**STEP 3:** Measure the height from grade line to footing. Add enough length to cover the top of the footing and cut pieces of membrane to length.

## 2.18.10.1 – BELOW GRADE WATERPROOFING CONTINUED

Also cut smaller 4" - 6" (102mm - 152mm) pieces to be applied as "corner caps". This will provide double ply protection in the corners.

**STEP 4:** Apply the "corner cap" pieces on each corner first.

**STEP 5:** Starting at a corner, line up the membrane so it is hanging vertically (using our vertical cut lines as a guide to keep membrane plumb). Pull back the first 8" - 10" (203mm - 254mm) of the release paper and press the membrane to the wall. Continue pulling back the release paper and pressing membrane to the wall.

**STEP 6:** Continue applying cut pieces of membrane around the wall, maintaining 2 inch (51 mm) overlap by using the printed marks on the membrane as a guide.

**NOTE:** Extreme temperatures, both cold and hot, may cause the installer to consider other types of waterproofing. Be sure to follow the manufacturer's installation process.



## 2.18.10.2 – ABOVE GRADE PARGING

The area that is above grade line and below the exterior siding material must be parged to protect the EPS from damage.

Parging is a coating material that is applied to give a finished appearance to the small area of wall that is above grade level but below where the siding materials will begin. LOGIX Prepcoat is the preferred option for this area.

**STEP 1:** Prep the wall area to be covered by removing any dirt or debris. The wall may need to be “scuffed” to reveal fresh EPS beads.

**STEP 2:** Mix Prepcoat dry material with water to a pasty consistency.

**STEP 3:** Using a trowel apply a thin, 1/16” - 1/8” (2mm - 3mm) “skim coat” of Prepcoat.

**STEP 4:** Pre-cut pieces of LOGIX fiber mesh 1” - 2” (25mm - 51mm) wider than the area to be parged. This will allow for an over-lap over the waterproofing membrane to create a “drip ledge”.

**STEP 5:** Embed the mesh in the skim coat firmly.

**STEP 6:** Once the area is dry to the touch apply a second coat of Prepcoat. This coat can be painted or stained if desired.

## 2.18.11 – ADDITIONAL SUPPORT FOR GRAB BARS, & OTHER HEAVY FIXTURES

Additional backing is recommended to support heavier wall fixtures, such as kitchen cabinetry, wall mounted fixtures, grab bars, hand rails, etc.

This can be accomplished in two ways:

### METHOD 1:

Plywood board can be attached to the LOGIX wall behind the heavier cabinets in place of gypsum board, providing a thermal barrier comparable to gypsum and a strong attachment surface for heavier items and fixtures. Be certain to attach the plywood board to the LOGIX webs with a sufficient number of screws to hold heavy items in place for when loads are applied.

### METHOD 2:

Create horizontal channels behind the cabinets equal in width to a 2x4 and install 2x4 backing directly to the concrete surface using sufficiently long concrete screws and a rotohammer. Attach the cabinets to the 2x4s.

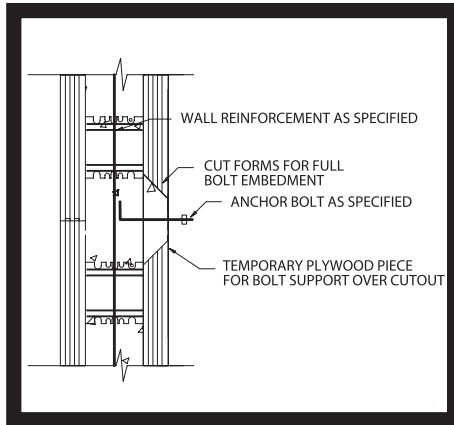
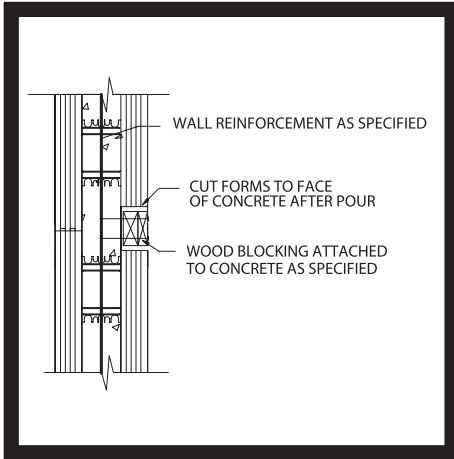

For full size CAD drawing see Section 5, CAD Drawings

## 2.18.12 – HOLDING POWER OF SCREWS FASTENED TO LOGIX FURRING TABS

Web fastener withdrawal and shear testing using coarse and fine thread drywall screws. Tests were conducted on furring tabs embedded 1/2 inch (52 mm) from the surface of the 2.75 inch (70 mm) LOGIX EPS panels .

	Max. Average Withdrawal Resistance	Allowable Withdrawal Resistance <sup>1</sup>	Max. Average Shear Resistance	Allowable Shear Resistance <sup>2</sup>
Coarse Thread Drywall Screw	166lb (75.3kg)	33lb (15.0kg)	367lb (166.5kg)	49lb (22.2kg)
Fine Thread Drywall Screw	169lb (76.7kg)	34lb (15.4kg)	328lb (148.8kg)	49lb (22.2kg)

1kg = 9.81 Newtons

1. Allowable withdrawal resistance values are based on a factor of safety of 5.
2. Allowable shear resistance values are based on a factor of safety of 3.2 within defined deflection limits (for more detailed information contact info@logixcf.com)

**NOTE:** The numbers in this table represent resistance at failure. Good building practice mandates a minimum of a 5 to 1 safety factor in calculating fastener loading. For complete test results on additional fasteners, see **Section 8** in the LOGIX Design Manual or consult your local LOGIX representative.

## 2.19 – COURSE HEIGHT TABLE

### COURSE HEIGHT TABLE

This table shows wall heights that are readily achieved using standard LOGIX blocks used in combination with a 4 inch (102 mm) Height Adjusters and/or 8 inch (203 mm) Half-height blocks.

INSTALLATION GUIDE

Number of Courses	Height of Wall	Add One Height Adj.	Add One Half-height	Add One Height Adj. & One Half-height
1	1' - 4" (406mm)	1' - 8" (508mm)	2' - 0" (610mm)	2' - 4" (711mm)
2	2' - 8" (813mm)	3' - 0" (914mm)	3' - 4" (1016mm)	3' - 8" (1118mm)
3	4' - 0" (1219mm)	4' - 4" (1321mm)	4' - 8" (1422mm)	5' - 0" (1524mm)
4	5' - 4" (1626mm)	5' - 8" (1727mm)	6' - 0" (1829mm)	6' - 4" (1930mm)
5	6' - 8" (2032mm)	7' - 0" (2134mm)	7' - 4" (2235mm)	7' - 8" (2337mm)
6	8' - 0" (2438mm)	8' - 4" (2540mm)	8' - 8" (2642mm)	9' - 0" (2743mm)
7	9' - 4" (2845mm)	9' - 8" (2946mm)	10' - 0" (3048mm)	10' - 4" (3150mm)
8	10' - 8" (3251mm)	11' - 0" (3353mm)	11' - 4" (3454mm)	11' - 8" (3556mm)
9	12' - 0" (3658mm)	12' - 4" (3759mm)	12' - 8" (3861mm)	13' - 0" (3962mm)
10	13' - 4" (4064mm)	13' - 8" (4166mm)	14' - 0" (4267mm)	14' - 4" (4369mm)
11	14' - 8" (4470mm)	15' - 0" (4572mm)	15' - 4" (4674mm)	15' - 8" (4775mm)
12	16' - 0" (4877mm)	16' - 4" (4978mm)	16' - 8" (5080mm)	17' - 0" (5182mm)
13	17' - 4" (5283mm)	17' - 8" (5385mm)	18' - 0" (5486mm)	18' - 4" (5588mm)
14	18' - 8" (5690mm)	19' - 0" (5791mm)	19' - 4" (5893mm)	19' - 8" (5994mm)
15	20' - 0" (6096mm)	20' - 4" (6198mm)	20' - 8" (6299mm)	21' - 0" (6401mm)
16	21' - 4" (6502mm)	21' - 8" (6604mm)	22' - 0" (6706mm)	22' - 4" (6807mm)
17	22' - 8" (6909mm)	23' - 0" (7010mm)	23' - 4" (7112mm)	23' - 8" (7214mm)
18	24' - 0" (7315mm)	24' - 4" (7417mm)	24' - 8" (7518mm)	25' - 0" (7620mm)
19	25' - 4" (7722mm)	25' - 8" (7823mm)	26' - 0" (7925mm)	26' - 4" (8026mm)
20	26' - 8" (8128mm)	27' - 0" (8230mm)	27' - 4" (8331mm)	27' - 8" (8433mm)
21	28' - 0" (8534mm)	28' - 4" (8636mm)	28' - 8" (8738mm)	29' - 0" (8839mm)
22	29' - 4" (8941mm)	29' - 8" (9042mm)	30' - 0" (9144mm)	30' - 4" (9246mm)
23	30' - 8" (9347mm)	31' - 0" (9449mm)	31' - 4" (9550mm)	31' - 8" (9652mm)
24	32' - 0" (9754mm)	32' - 4" (9855mm)	32' - 8" (9957mm)	33' - 0" (10058mm)
25	33' - 4" (10160mm)	33' - 8" (10262mm)	34' - 0" (10363mm)	34' - 4" (10465mm)

## 2.20 – RADIUS WALLS

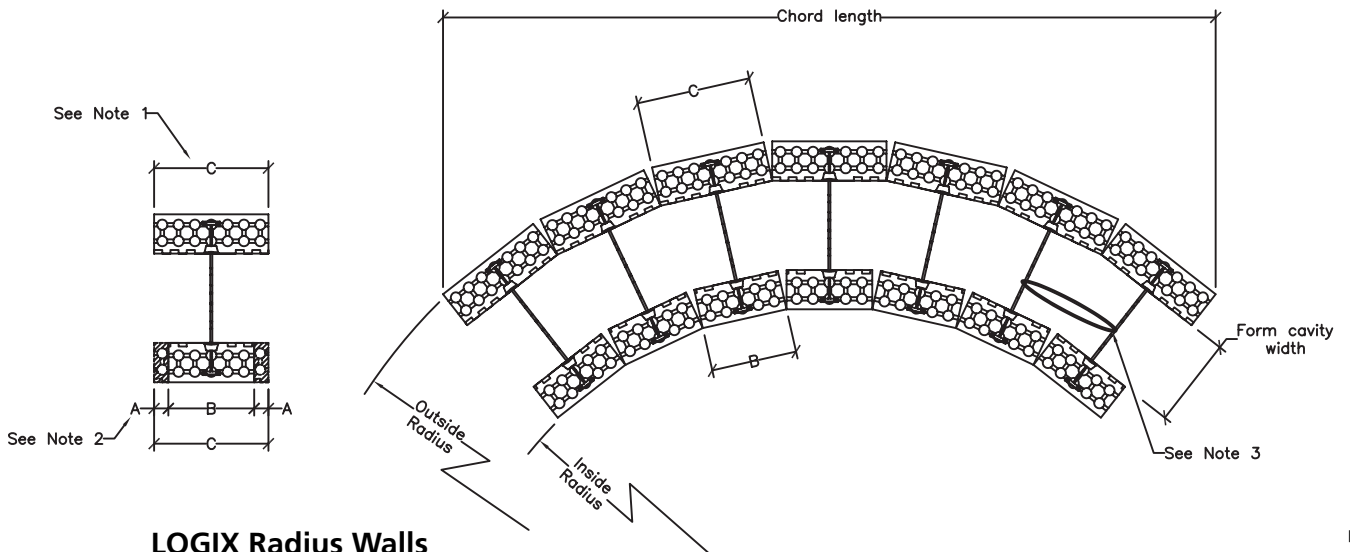

**LOGIX Radius Walls**

Outside Radius, ft. (m)	Form Cavity Width							
	4" (102mm)		6.25" (159mm)		8" (203mm)		10" (254mm)	
	C, in. (mm)	A, in. (mm)	C, in. (mm)	A, in. (mm)	C, in. (mm)	A, in. (mm)	C, in. (mm)	A, in. (mm)
3 (0.914)	8 (203)	13/16 (21)	8 (203)	1 3/32 (28)	8 (203)	1 19/64 (33)	8 (203)	1 35/64 (39)
3.5 (1.067)	8 (203)	11/16 (17)	8 (203)	59/64 (23)	8 (203)	1 3/32 (28)	8 (203)	1 19/64 (33)
4 (1.219)	8 (203)	19/32 (15)	8 (203)	51/64 (20)	8 (203)	61/64 (24)	8 (203)	1 1/8 (29)
4.5 (1.372)	8 (203)	17/32 (13)	8 (203)	45/64 (18)	8 (203)	27/32 (21)	8 (203)	1 (25)
5 (1.524)	8 (203)	15/32 (12)	8 (203)	5/8 (16)	8 (203)	3/4 (19)	8 (203)	57/64 (23)
5.5 (1.676)	8 (203)	27/64 (11)	8 (203)	9/16 (14)	8 (203)	43/64 (17)	8 (203)	51/64 (20)
6 (1.829)	8 (203)	25/64 (10)	8 (203)	33/64 (13)	8 (203)	5/8 (16)	8 (203)	47/64 (19)
6.5 (1.981)	8 (203)	23/64 (9)	8 (203)	15/32 (12)	8 (203)	9/16 (14)	8 (203)	43/64 (17)
7 (2.134)	8 (203)	21/64 (8)	8 (203)	7/16 (11)	8 (203)	17/32 (13)	8 (203)	5/8 (16)

**NOTES:**

1. Field cut LOGIX Standard forms (straight forms) into widths, C, according to LOGIX Radius Walls table. For inside radius field cut additional foam, A, accordingly.
2. Secure each radius section with zip ties, tape or foam.
3. The field cuts, C, are kept at 8" (203mm), 16" (406mm), 24" (610mm) or 48" (1220mm) lengths. The field cuts, A, are determined depending on required radius. The combined field cuts, A and C, results in an outside radius which is within 1% of the design radius for radii less than 60ft (18.3m), and 1% to 2% for radii between 60ft and 100ft (18.3m to 30.5m).

INSTALLATION GUIDE

<a href="http://www.logixicf.com" style="color: white;">www.logixicf.com</a>	<b>LOGIX</b> <sup>®</sup> INSULATED CONCRETE FORMS
<b>Good. Solid. Green.</b> <sup>™</sup>	2-99

REPRINTED 2011

## 2.20 – RADIUS WALLS CONTINUED

INSTALLATION GUIDE

Outside Radius, ft. (m)	Form Cavity Width							
	4" (102mm)		6.25" (159mm)		8" (203mm)		10" (254mm)	
	C, in. (mm)	A, in. (mm)	C, in. (mm)	A, in. (mm)	C, in. (mm)	A, in. (mm)	C, in. (mm)	A, in. (mm)
7.5 (2.286)	8 (203)	5/16 (8)	8 (203)	13/32 (10)	8 (203)	31/64 (12)	8 (203)	37/64 (15)
8 (2.438)	8 (203)	9/32 (7)	8 (203)	3/8 (10)	8 (203)	29/64 (12)	8 (203)	35/64 (14)
8.5 (2.591)	8 (203)	17/64 (7)	8 (203)	23/64 (9)	8 (203)	27/64 (11)	8 (203)	33/64 (13)
9 (2.743)	8 (203)	1/4 (6)	8 (203)	11/32 (9)	8 (203)	13/32 (10)	8 (203)	31/64 (12)
9.5 (2.896)	8 (203)	15/64 (6)	16 (406)	41/64 (16)	8 (203)	25/64 (10)	8 (203)	29/64 (12)
10 (3.048)	16 (406)	29/64 (12)	16 (406)	39/64 (15)	8 (203)	23/64 (9)	8 (203)	7/16 (11)
10.5 (3.200)	16 (406)	7/16 (11)	16 (406)	37/64 (15)	8 (203)	11/32 (9)	8 (203)	13/32 (10)
11 (3.353)	16 (406)	27/64 (11)	16 (406)	35/64 (14)	8 (203)	21/64 (8)	8 (203)	25/64 (10)
11.5 (3.505)	16 (406)	25/64 (10)	16 (406)	17/32 (13)	8 (203)	5/16 (8)	8 (203)	3/8 (10)
12 (3.658)	16 (406)	3/8 (10)	16 (406)	1/2 (13)	8 (203)	19/64 (8)	8 (203)	23/64 (9)
12.5 (3.810)	16 (406)	23/64 (9)	16 (406)	31/64 (12)	16 (406)	37/64 (15)	8 (203)	11/32 (9)
13 (3.962)	16 (406)	11/32 (9)	16 (406)	15/32 (12)	8 (203)	9/32 (7)	8 (203)	21/64 (8)
13.5 (4.115)	16 (406)	21/64 (8)	16 (406)	29/64 (12)	16 (406)	17/32 (13)	8 (203)	5/16 (8)
14 (4.267)	16 (406)	21/64 (8)	16 (406)	7/16 (11)	8 (203)	1/4 (6)	16 (406)	39/64 (15)
14.5 (4.420)	16 (406)	5/16 (8)	16 (406)	27/64 (11)	8 (203)	1/4 (6)	16 (406)	19/32 (15)
15 (4.572)	16 (406)	19/64 (8)	16 (406)	13/32 (10)	8 (203)	15/64 (6)	16 (406)	37/64 (15)
15.5 (4.724)	16 (406)	19/64 (8)	16 (406)	25/64 (10)	8 (203)	15/64 (6)	16 (406)	35/64 (14)
16 (4.877)	24 (610)	27/64 (11)	16 (406)	3/8 (10)	8 (203)	7/32 (6)	16 (406)	17/32 (13)
16.5 (5.029)	24 (610)	13/32 (10)	16 (406)	23/64 (9)	8 (203)	7/32 (6)	16 (406)	33/64 (13)
17 (5.182)	24 (610)	13/32 (10)	16 (406)	23/64 (9)	16 (406)	27/64 (11)	16 (406)	1/2 (13)
17.5 (5.334)	24 (610)	25/64 (10)	24 (610)	33/64 (13)	16 (406)	13/32 (10)	16 (406)	31/64 (12)
18 (5.486)	24 (610)	3/8 (10)	24 (610)	1/2 (13)	16 (406)	13/32 (10)	16 (406)	15/32 (12)
18.5 (5.639)	24 (610)	23/64 (9)	24 (610)	31/64 (12)	16 (406)	25/64 (10)	16 (406)	15/32 (12)
19 (5.791)	24 (610)	23/64 (9)	24 (610)	15/32 (12)	16 (406)	3/8 (10)	16 (406)	29/64 (12)

[www.logixcf.com](http://www.logixcf.com)

**Good. Solid. Green.™**

**2-100**



## 2.20 – RADIUS WALLS CONTINUED

Outside Radius, ft. (m)	Form Cavity Width							
	4" (102mm)		6.25" (159mm)		8" (203mm)		10" (254mm)	
	C, in. (mm)	A, in. (mm)	C, in. (mm)	A, in. (mm)	C, in. (mm)	A, in. (mm)	C, in. (mm)	A, in. (mm)
19.5 (5.944)	24 (610)	11/32 (9)	24 (610)	15/32 (12)	16 (406)	3/8 (10)	16 (406)	7/16 (11)
20 (6.096)	24 (610)	11/32 (9)	24 (610)	29/64 (12)	16 (406)	23/64 (9)	16 (406)	27/64 (11)
20.5 (6.248)	24 (610)	21/64 (8)	24 (610)	7/16 (11)	16 (406)	11/32 (9)	16 (406)	27/64 (11)
21 (6.401)	24 (610)	21/64 (8)	24 (610)	7/16 (11)	16 (406)	11/32 (9)	16 (406)	13/32 (10)
21.5 (6.553)	24 (610)	5/16 (8)	24 (610)	27/64 (11)	16 (406)	21/64 (8)	16 (406)	25/64 (10)
22 (6.706)	24 (610)	5/16 (8)	24 (610)	13/32 (10)	16 (406)	21/64 (8)	16 (406)	25/64 (10)
22.5 (6.858)	24 (610)	19/64 (8)	24 (610)	13/32 (10)	16 (406)	5/16 (8)	16 (406)	3/8 (10)
23 (7.010)	24 (610)	19/64 (8)	24 (610)	25/64 (10)	16 (406)	5/16 (8)	16 (406)	3/8 (10)
23.5 (7.163)	24 (610)	9/32 (7)	24 (610)	25/64 (10)	24 (610)	29/64 (12)	16 (406)	23/64 (9)
24 (7.315)	24 (610)	9/32 (7)	24 (610)	3/8 (10)	24 (610)	29/64 (12)	16 (406)	23/64 (9)
24.5 (7.468)	24 (610)	9/32 (7)	48 (1,219)	47/64 (19)	24 (610)	7/16 (11)	16 (406)	11/32 (9)
25 (7.620)	24 (610)	17/64 (7)	48 (1,219)	23/32 (18)	24 (610)	7/16 (11)	16 (406)	11/32 (9)
25.5 (7.772)	24 (610)	17/64 (7)	48 (1,219)	45/64 (18)	24 (610)	27/64 (11)	16 (406)	21/64 (8)
26 (7.925)	48 (1,219)	33/64 (13)	48 (1,219)	45/64 (18)	24 (610)	13/32 (10)	16 (406)	21/64 (8)
26.5 (8.077)	48 (1,219)	33/64 (13)	48 (1,219)	11/16 (17)	24 (610)	13/32 (10)	16 (406)	5/16 (8)
27 (8.230)	48 (1,219)	1/2 (13)	48 (1,219)	43/64 (17)	24 (610)	25/64 (10)	16 (406)	5/16 (8)
27.5 (8.382)	48 (1,219)	1/2 (13)	48 (1,219)	21/32 (17)	24 (610)	25/64 (10)	16 (406)	5/16 (8)
28 (8.534)	48 (1,219)	31/64 (12)	48 (1,219)	41/64 (16)	24 (610)	25/64 (10)	16 (406)	19/64 (8)
28.5 (8.687)	48 (1,219)	15/32 (12)	48 (1,219)	41/64 (16)	24 (610)	3/8 (10)	24 (610)	29/64 (12)
29 (8.839)	48 (1,219)	15/32 (12)	48 (1,219)	5/8 (16)	24 (610)	3/8 (10)	24 (610)	7/16 (11)
29.5 (8.992)	48 (1,219)	29/64 (12)	48 (1,219)	39/64 (15)	24 (610)	23/64 (9)	24 (610)	7/16 (11)
30 (9.144)	48 (1,219)	29/64 (12)	48 (1,219)	39/64 (15)	24 (610)	23/64 (9)	24 (610)	27/64 (11)
30.5 (9.296)	48 (1,219)	7/16 (11)	48 (1,219)	19/32 (15)	48 (1,219)	45/64 (18)	24 (610)	27/64 (11)
31 (9.449)	48 (1,219)	7/16 (11)	48 (1,219)	37/64 (15)	48 (1,219)	45/64 (18)	24 (610)	13/32 (10)

INSTALLATION GUIDE

<b>Good. Solid. Green.™</b>	<a href="http://www.logixicf.com">www.logixicf.com</a> <b>2-101</b>	
-----------------------------	--	---

REPRINTED 2011

## 2.20 – RADIUS WALLS CONTINUED

INSTALLATION GUIDE

Outside Radius, ft. (m)	Form Cavity Width							
	4" (102mm)		6.25" (159mm)		8" (203mm)		10" (254mm)	
	C, in. (mm)	A, in. (mm)	C, in. (mm)	A, in. (mm)	C, in. (mm)	A, in. (mm)	C, in. (mm)	A, in. (mm)
31.5 (9.601)	48 (1,219)	27/64 (11)	48 (1,219)	37/64 (15)	48 (1,219)	11/16 (17)	24 (610)	13/32 (10)
32 (9.754)	48 (1,219)	27/64 (11)	48 (1,219)	9/16 (14)	48 (1,219)	43/64 (17)	24 (610)	25/64 (10)
32.5 (9.906)	48 (1,219)	27/64 (11)	48 (1,219)	9/16 (14)	48 (1,219)	21/32 (17)	24 (610)	25/64 (10)
33 (10.058)	48 (1,219)	13/32 (10)	48 (1,219)	35/64 (14)	48 (1,219)	21/32 (17)	24 (610)	25/64 (10)
33.5 (10.211)	48 (1,219)	13/32 (10)	48 (1,219)	17/32 (13)	48 (1,219)	41/64 (16)	24 (610)	3/8 (10)
34 (10.363)	48 (1,219)	25/64 (10)	48 (1,219)	17/32 (13)	48 (1,219)	41/64 (16)	24 (610)	3/8 (10)
34.5 (10.516)	48 (1,219)	25/64 (10)	48 (1,219)	33/64 (13)	48 (1,219)	5/8 (16)	24 (610)	3/8 (10)
35 (10.668)	48 (1,219)	25/64 (10)	48 (1,219)	33/64 (13)	48 (1,219)	39/64 (15)	24 (610)	23/64 (9)
35.5 (10.820)	48 (1,219)	3/8 (10)	48 (1,219)	1/2 (13)	48 (1,219)	39/64 (15)	24 (610)	23/64 (9)
36 (10.973)	48 (1,219)	3/8 (10)	48 (1,219)	1/2 (13)	48 (1,219)	19/32 (15)	24 (610)	23/64 (9)
36.5 (11.125)	48 (1,219)	3/8 (10)	48 (1,219)	1/2 (13)	48 (1,219)	19/32 (15)	24 (610)	11/32 (9)
37 (11.278)	48 (1,219)	23/64 (9)	48 (1,219)	31/64 (12)	48 (1,219)	37/64 (15)	24 (610)	11/32 (9)
37.5 (11.430)	48 (1,219)	23/64 (9)	48 (1,219)	31/64 (12)	48 (1,219)	37/64 (15)	24 (610)	11/32 (9)
38 (11.582)	48 (1,219)	23/64 (9)	48 (1,219)	15/32 (12)	48 (1,219)	9/16 (14)	24 (610)	21/64 (8)
38.5 (11.735)	48 (1,219)	11/32 (9)	48 (1,219)	15/32 (12)	48 (1,219)	9/16 (14)	24 (610)	21/64 (8)
39 (11.887)	48 (1,219)	11/32 (9)	48 (1,219)	15/32 (12)	48 (1,219)	35/64 (14)	24 (610)	21/64 (8)
39.5 (12.040)	48 (1,219)	11/32 (9)	48 (1,219)	29/64 (12)	48 (1,219)	35/64 (14)	24 (610)	21/64 (8)
40 (12.192)	48 (1,219)	11/32 (9)	48 (1,219)	29/64 (12)	48 (1,219)	17/32 (13)	24 (610)	5/16 (8)
40.5 (12.344)	48 (1,219)	21/64 (8)	48 (1,219)	7/16 (11)	48 (1,219)	17/32 (13)	48 (1,219)	5/8 (16)
41 (12.497)	48 (1,219)	21/64 (8)	48 (1,219)	7/16 (11)	48 (1,219)	17/32 (13)	48 (1,219)	5/8 (16)
41.5 (12.649)	48 (1,219)	21/64 (8)	48 (1,219)	7/16 (11)	48 (1,219)	33/64 (13)	48 (1,219)	39/64 (15)
42 (12.802)	48 (1,219)	5/16 (8)	48 (1,219)	27/64 (11)	48 (1,219)	33/64 (13)	48 (1,219)	39/64 (15)
42.5 (12.954)	48 (1,219)	5/16 (8)	48 (1,219)	27/64 (11)	48 (1,219)	1/2 (13)	48 (1,219)	19/32 (15)
43 (13.106)	48 (1,219)	5/16 (8)	48 (1,219)	27/64 (11)	48 (1,219)	1/2 (13)	48 (1,219)	19/32 (15)

[www.logixcf.com](http://www.logixcf.com)

**Good. Solid. Green.™**

**2 – 102**



## 2.20 – RADIUS WALLS CONTINUED

Outside Radius, ft. (m)	Form Cavity Width							
	4" (102mm)		6.25" (159mm)		8" (203mm)		10" (254mm)	
	C, in. (mm)	A, in. (mm)	C, in. (mm)	A, in. (mm)	C, in. (mm)	A, in. (mm)	C, in. (mm)	A, in. (mm)
43.5 (13.259)	48 (1,219)	5/16 (8)	48 (1,219)	13/32 (10)	48 (1,219)	1/2 (13)	48 (1,219)	19/32 (15)
44 (13.411)	48 (1,219)	5/16 (8)	48 (1,219)	13/32 (10)	48 (1,219)	31/64 (12)	48 (1,219)	37/64 (15)
44.5 (13.564)	48 (1,219)	19/64 (8)	48 (1,219)	13/32 (10)	48 (1,219)	31/64 (12)	48 (1,219)	37/64 (15)
45 (13.716)	48 (1,219)	19/64 (8)	48 (1,219)	13/32 (10)	48 (1,219)	31/64 (12)	48 (1,219)	9/16 (14)
45.5 (13.868)	48 (1,219)	19/64 (8)	48 (1,219)	25/64 (10)	48 (1,219)	15/32 (12)	48 (1,219)	9/16 (14)
46 (14.021)	48 (1,219)	19/64 (8)	48 (1,219)	25/64 (10)	48 (1,219)	15/32 (12)	48 (1,219)	35/64 (14)
46.5 (14.173)	48 (1,219)	9/32 (7)	48 (1,219)	25/64 (10)	48 (1,219)	15/32 (12)	48 (1,219)	35/64 (14)
47 (14.326)	48 (1,219)	9/32 (7)	48 (1,219)	3/8 (10)	48 (1,219)	29/64 (12)	48 (1,219)	35/64 (14)
47.5 (14.478)	48 (1,219)	9/32 (7)	48 (1,219)	3/8 (10)	48 (1,219)	29/64 (12)	48 (1,219)	17/32 (13)
48 (14.630)	48 (1,219)	9/32 (7)	48 (1,219)	3/8 (10)	48 (1,219)	29/64 (12)	48 (1,219)	17/32 (13)
48.5 (14.783)	48 (1,219)	9/32 (7)	48 (1,219)	3/8 (10)	48 (1,219)	7/16 (11)	48 (1,219)	17/32 (13)
49 (14.935)	48 (1,219)	17/64 (7)	48 (1,219)	23/64 (9)	48 (1,219)	7/16 (11)	48 (1,219)	33/64 (13)
49.5 (15.088)	48 (1,219)	17/64 (7)	48 (1,219)	23/64 (9)	48 (1,219)	7/16 (11)	48 (1,219)	33/64 (13)
50 (15.240)	48 (1,219)	17/64 (7)	48 (1,219)	23/64 (9)	48 (1,219)	27/64 (11)	48 (1,219)	33/64 (13)
50.5 (15.392)	48 (1,219)	17/64 (7)	48 (1,219)	23/64 (9)	48 (1,219)	27/64 (11)	48 (1,219)	1/2 (13)
51 (15.545)	48 (1,219)	17/64 (7)	48 (1,219)	11/32 (9)	48 (1,219)	27/64 (11)	48 (1,219)	1/2 (13)
51.5 (15.697)	48 (1,219)	17/64 (7)	48 (1,219)	11/32 (9)	48 (1,219)	27/64 (11)	48 (1,219)	1/2 (13)
52 (15.850)	48 (1,219)	1/4 (6)	48 (1,219)	11/32 (9)	48 (1,219)	13/32 (10)	48 (1,219)	31/64 (12)
52.5 (16.002)	48 (1,219)	1/4 (6)	48 (1,219)	11/32 (9)	48 (1,219)	13/32 (10)	48 (1,219)	31/64 (12)
53 (16.154)	48 (1,219)	1/4 (6)	48 (1,219)	11/32 (9)	48 (1,219)	13/32 (10)	48 (1,219)	31/64 (12)
53.5 (16.307)	48 (1,219)	1/4 (6)	48 (1,219)	21/64 (8)	48 (1,219)	13/32 (10)	48 (1,219)	15/32 (12)
54 (16.459)	48 (1,219)	1/4 (6)	48 (1,219)	21/64 (8)	48 (1,219)	25/64 (10)	48 (1,219)	15/32 (12)
54.5 (16.612)	48 (1,219)	1/4 (6)	48 (1,219)	21/64 (8)	48 (1,219)	25/64 (10)	48 (1,219)	15/32 (12)
55 (16.764)	48 (1,219)	1/4 (6)	48 (1,219)	21/64 (8)	48 (1,219)	25/64 (10)	48 (1,219)	15/32 (12)

INSTALLATION GUIDE

<p><b>Good. Solid. Green.™</b></p>	<p><a href="http://www.logixicf.com">www.logixicf.com</a></p> <p><b>2-103</b></p>	
------------------------------------	---	---

REPRINTED 2011

## 2.20 – RADIUS WALLS CONTINUED

INSTALLATION GUIDE

Outside Radius, ft. (m)	Form Cavity Width							
	4" (102mm)		6.25" (159mm)		8" (203mm)		10" (254mm)	
	C, in. (mm)	A, in. (mm)	C, in. (mm)	A, in. (mm)	C, in. (mm)	A, in. (mm)	C, in. (mm)	A, in. (mm)
55.5 (16.916)	48 (1,219)	15/64 (6)	48 (1,219)	21/64 (8)	48 (1,219)	25/64 (10)	48 (1,219)	29/64 (12)
56 (17.069)	48 (1,219)	15/64 (6)	48 (1,219)	5/16 (8)	48 (1,219)	3/8 (10)	48 (1,219)	29/64 (12)
56.5 (17.221)	48 (1,219)	15/64 (6)	48 (1,219)	5/16 (8)	48 (1,219)	3/8 (10)	48 (1,219)	29/64 (12)
57 (17.374)	48 (1,219)	15/64 (6)	48 (1,219)	5/16 (8)	48 (1,219)	3/8 (10)	48 (1,219)	29/64 (12)
57.5 (17.526)	48 (1,219)	15/64 (6)	48 (1,219)	5/16 (8)	48 (1,219)	3/8 (10)	48 (1,219)	7/16 (11)
58 (17.678)	48 (1,219)	15/64 (6)	48 (1,219)	5/16 (8)	48 (1,219)	3/8 (10)	48 (1,219)	7/16 (11)
58.5 (17.831)	48 (1,219)	15/64 (6)	48 (1,219)	5/16 (8)	48 (1,219)	23/64 (9)	48 (1,219)	7/16 (11)
59 (17.983)	48 (1,219)	7/32 (6)	48 (1,219)	19/64 (8)	48 (1,219)	23/64 (9)	48 (1,219)	7/16 (11)
59.5 (18.136)	48 (1,219)	7/32 (6)	48 (1,219)	19/64 (8)	48 (1,219)	23/64 (9)	48 (1,219)	27/64 (11)
60 (18.288)	48 (1,219)	7/32 (6)	48 (1,219)	19/64 (8)	48 (1,219)	23/64 (9)	48 (1,219)	27/64 (11)
60.5 (18.440)	48 (1,219)	7/32 (6)	48 (1,219)	19/64 (8)	48 (1,219)	23/64 (9)	48 (1,219)	27/64 (11)
61 (18.593)	48 (1,219)	7/32 (6)	48 (1,219)	19/64 (8)	48 (1,219)	11/32 (9)	48 (1,219)	27/64 (11)
61.5 (18.745)	48 (1,219)	7/32 (6)	48 (1,219)	19/64 (8)	48 (1,219)	11/32 (9)	48 (1,219)	13/32 (10)
62 (18.898)	48 (1,219)	7/32 (6)	48 (1,219)	9/32 (7)	48 (1,219)	11/32 (9)	48 (1,219)	13/32 (10)
62.5 (19.050)	48 (1,219)	7/32 (6)	48 (1,219)	9/32 (7)	48 (1,219)	11/32 (9)	48 (1,219)	13/32 (10)
63 (19.202)	48 (1,219)	7/32 (6)	48 (1,219)	9/32 (7)	48 (1,219)	11/32 (9)	48 (1,219)	13/32 (10)
63.5 (19.355)	48 (1,219)	13/64 (5)	48 (1,219)	9/32 (7)	48 (1,219)	11/32 (9)	48 (1,219)	13/32 (10)
64 (19.507)	48 (1,219)	13/64 (5)	48 (1,219)	9/32 (7)	48 (1,219)	21/64 (8)	48 (1,219)	25/64 (10)
64.5 (19.660)	48 (1,219)	13/64 (5)	48 (1,219)	9/32 (7)	48 (1,219)	21/64 (8)	48 (1,219)	25/64 (10)
65 (19.812)	48 (1,219)	13/64 (5)	48 (1,219)	9/32 (7)	48 (1,219)	21/64 (8)	48 (1,219)	25/64 (10)
65.5 (19.964)	48 (1,219)	13/64 (5)	48 (1,219)	17/64 (7)	48 (1,219)	21/64 (8)	48 (1,219)	25/64 (10)
66 (20.117)	48 (1,219)	13/64 (5)	48 (1,219)	17/64 (7)	48 (1,219)	21/64 (8)	48 (1,219)	25/64 (10)
66.5 (20.269)	48 (1,219)	13/64 (5)	48 (1,219)	17/64 (7)	48 (1,219)	21/64 (8)	48 (1,219)	3/8 (10)
67 (20.422)	48 (1,219)	13/64 (5)	48 (1,219)	17/64 (7)	48 (1,219)	5/16 (8)	48 (1,219)	3/8 (10)

[www.logixcf.com](http://www.logixcf.com)

**Good. Solid. Green.™**

**2-104**



## 2.20 – RADIUS WALLS CONTINUED

Outside Radius, ft. (m)	Form Cavity Width							
	4" (102mm)		6.25" (159mm)		8" (203mm)		10" (254mm)	
	C, in. (mm)	A, in. (mm)	C, in. (mm)	A, in. (mm)	C, in. (mm)	A, in. (mm)	C, in. (mm)	A, in. (mm)
67.5 (20.574)	48 (1,219)	13/64 (5)	48 (1,219)	17/64 (7)	48 (1,219)	5/16 (8)	48 (1,219)	3/8 (10)
68 (20.726)	48 (1,219)	13/64 (5)	48 (1,219)	17/64 (7)	48 (1,219)	5/16 (8)	48 (1,219)	3/8 (10)
68.5 (20.879)	48 (1,219)	3/16 (5)	48 (1,219)	17/64 (7)	48 (1,219)	5/16 (8)	48 (1,219)	3/8 (10)
69 (21.031)	48 (1,219)	3/16 (5)	48 (1,219)	17/64 (7)	48 (1,219)	5/16 (8)	48 (1,219)	23/64 (9)
69.5 (21.184)	48 (1,219)	3/16 (5)	48 (1,219)	1/4 (6)	48 (1,219)	5/16 (8)	48 (1,219)	23/64 (9)
70 (21.336)	48 (1,219)	3/16 (5)	48 (1,219)	1/4 (6)	48 (1,219)	19/64 (8)	48 (1,219)	23/64 (9)
70.5 (21.488)	48 (1,219)	3/16 (5)	48 (1,219)	1/4 (6)	48 (1,219)	19/64 (8)	48 (1,219)	23/64 (9)
71 (21.641)	48 (1,219)	3/16 (5)	48 (1,219)	1/4 (6)	48 (1,219)	19/64 (8)	48 (1,219)	23/64 (9)
71.5 (21.793)	48 (1,219)	3/16 (5)	48 (1,219)	1/4 (6)	48 (1,219)	19/64 (8)	48 (1,219)	23/64 (9)
72 (21.946)	48 (1,219)	3/16 (5)	48 (1,219)	1/4 (6)	48 (1,219)	19/64 (8)	48 (1,219)	11/32 (9)
72.5 (22.098)	48 (1,219)	3/16 (5)	48 (1,219)	1/4 (6)	48 (1,219)	19/64 (8)	48 (1,219)	11/32 (9)
73 (22.250)	48 (1,219)	3/16 (5)	48 (1,219)	1/4 (6)	48 (1,219)	19/64 (8)	48 (1,219)	11/32 (9)
73.5 (22.403)	48 (1,219)	3/16 (5)	48 (1,219)	15/64 (6)	48 (1,219)	19/64 (8)	48 (1,219)	11/32 (9)
74 (22.555)	48 (1,219)	11/64 (4)	48 (1,219)	15/64 (6)	48 (1,219)	9/32 (7)	48 (1,219)	11/32 (9)
74.5 (22.708)	48 (1,219)	11/64 (4)	48 (1,219)	15/64 (6)	48 (1,219)	9/32 (7)	48 (1,219)	11/32 (9)
75 (22.860)	48 (1,219)	11/64 (4)	48 (1,219)	15/64 (6)	48 (1,219)	9/32 (7)	48 (1,219)	11/32 (9)
75.5 (23.012)	48 (1,219)	11/64 (4)	48 (1,219)	15/64 (6)	48 (1,219)	9/32 (7)	48 (1,219)	21/64 (8)
76 (23.165)	48 (1,219)	11/64 (4)	48 (1,219)	15/64 (6)	48 (1,219)	9/32 (7)	48 (1,219)	21/64 (8)
76.5 (23.317)	48 (1,219)	11/64 (4)	48 (1,219)	15/64 (6)	48 (1,219)	9/32 (7)	48 (1,219)	21/64 (8)
77 (23.470)	48 (1,219)	11/64 (4)	48 (1,219)	15/64 (6)	48 (1,219)	9/32 (7)	48 (1,219)	21/64 (8)
77.5 (23.622)	48 (1,219)	11/64 (4)	48 (1,219)	15/64 (6)	48 (1,219)	9/32 (7)	48 (1,219)	21/64 (8)
78 (23.774)	48 (1,219)	11/64 (4)	48 (1,219)	15/64 (6)	48 (1,219)	17/64 (7)	48 (1,219)	21/64 (8)
78.5 (23.927)	48 (1,219)	11/64 (4)	48 (1,219)	7/32 (6)	48 (1,219)	17/64 (7)	48 (1,219)	21/64 (8)
79 (24.079)	48 (1,219)	11/64 (4)	48 (1,219)	7/32 (6)	48 (1,219)	17/64 (7)	48 (1,219)	5/16 (8)

INSTALLATION GUIDE

<p><b>Good. Solid. Green.™</b></p>	<p><a href="http://www.logixicf.com">www.logixicf.com</a></p> <p><b>2-105</b></p>	
------------------------------------	---	---

REPRINTED 2011

## 2.20 – RADIUS WALLS CONTINUED

INSTALLATION GUIDE

Outside Radius, ft. (m)	Form Cavity Width							
	4" (102mm)		6.25" (159mm)		8" (203mm)		10" (254mm)	
	C, in. (mm)	A, in. (mm)	C, in. (mm)	A, in. (mm)	C, in. (mm)	A, in. (mm)	C, in. (mm)	A, in. (mm)
79.5 (24.232)	48 (1,219)	11/64 (4)	48 (1,219)	7/32 (6)	48 (1,219)	17/64 (7)	48 (1,219)	5/16 (8)
80 (24.384)	48 (1,219)	11/64 (4)	48 (1,219)	7/32 (6)	48 (1,219)	17/64 (7)	48 (1,219)	5/16 (8)
80.5 (24.536)	48 (1,219)	11/64 (4)	48 (1,219)	7/32 (6)	48 (1,219)	17/64 (7)	48 (1,219)	5/16 (8)
81 (24.689)	48 (1,219)	5/32 (4)	48 (1,219)	7/32 (6)	48 (1,219)	17/64 (7)	48 (1,219)	5/16 (8)
81.5 (24.841)	48 (1,219)	5/32 (4)	48 (1,219)	7/32 (6)	48 (1,219)	17/64 (7)	48 (1,219)	5/16 (8)
82 (24.994)	48 (1,219)	5/32 (4)	48 (1,219)	7/32 (6)	48 (1,219)	17/64 (7)	48 (1,219)	5/16 (8)
82.5 (25.146)	48 (1,219)	5/32 (4)	48 (1,219)	7/32 (6)	48 (1,219)	1/4 (6)	48 (1,219)	5/16 (8)
83 (25.298)	48 (1,219)	5/32 (4)	48 (1,219)	7/32 (6)	48 (1,219)	1/4 (6)	48 (1,219)	19/64 (8)
83.5 (25.451)	48 (1,219)	5/32 (4)	48 (1,219)	7/32 (6)	48 (1,219)	1/4 (6)	48 (1,219)	19/64 (8)
84 (25.603)	48 (1,219)	5/32 (4)	48 (1,219)	7/32 (6)	48 (1,219)	1/4 (6)	48 (1,219)	19/64 (8)
84.5 (25.756)	48 (1,219)	5/32 (4)	48 (1,219)	13/64 (5)	48 (1,219)	1/4 (6)	48 (1,219)	19/64 (8)
85 (25.908)	48 (1,219)	5/32 (4)	48 (1,219)	13/64 (5)	48 (1,219)	1/4 (6)	48 (1,219)	19/64 (8)
85.5 (26.060)	48 (1,219)	5/32 (4)	48 (1,219)	13/64 (5)	48 (1,219)	1/4 (6)	48 (1,219)	19/64 (8)
86 (26.213)	48 (1,219)	5/32 (4)	48 (1,219)	13/64 (5)	48 (1,219)	1/4 (6)	48 (1,219)	19/64 (8)
86.5 (26.365)	48 (1,219)	5/32 (4)	48 (1,219)	13/64 (5)	48 (1,219)	1/4 (6)	48 (1,219)	19/64 (8)
87 (26.518)	48 (1,219)	5/32 (4)	48 (1,219)	13/64 (5)	48 (1,219)	1/4 (6)	48 (1,219)	19/64 (8)
87.5 (26.670)	48 (1,219)	5/32 (4)	48 (1,219)	13/64 (5)	48 (1,219)	1/4 (6)	48 (1,219)	9/32 (7)
88 (26.822)	48 (1,219)	5/32 (4)	48 (1,219)	13/64 (5)	48 (1,219)	15/64 (6)	48 (1,219)	9/32 (7)
88.5 (26.975)	48 (1,219)	5/32 (4)	48 (1,219)	13/64 (5)	48 (1,219)	15/64 (6)	48 (1,219)	9/32 (7)
89 (27.127)	48 (1,219)	9/64 (4)	48 (1,219)	13/64 (5)	48 (1,219)	15/64 (6)	48 (1,219)	9/32 (7)
89.5 (27.280)	48 (1,219)	9/64 (4)	48 (1,219)	13/64 (5)	48 (1,219)	15/64 (6)	48 (1,219)	9/32 (7)
90 (27.432)	48 (1,219)	9/64 (4)	48 (1,219)	13/64 (5)	48 (1,219)	15/64 (6)	48 (1,219)	9/32 (7)
90.5 (27.584)	48 (1,219)	9/64 (4)	48 (1,219)	13/64 (5)	48 (1,219)	15/64 (6)	48 (1,219)	9/32 (7)
91 (27.737)	48 (1,219)	9/64 (4)	48 (1,219)	3/16 (5)	48 (1,219)	15/64 (6)	48 (1,219)	9/32 (7)

[www.logixcf.com](http://www.logixcf.com)

**Good. Solid. Green.™**

**2-106**



## 2.20 – RADIUS WALLS CONTINUED

Outside Radius, ft. (m)	Form Cavity Width							
	4" (102mm)		6.25" (159mm)		8" (203mm)		10" (254mm)	
	C, in. (mm)	A, in. (mm)	C, in. (mm)	A, in. (mm)	C, in. (mm)	A, in. (mm)	C, in. (mm)	A, in. (mm)
91.5 (27.889)	48 (1,219)	9/64 (4)	48 (1,219)	3/16 (5)	48 (1,219)	15/64 (6)	48 (1,219)	9/32 (7)
92 (28.042)	48 (1,219)	9/64 (4)	48 (1,219)	3/16 (5)	48 (1,219)	15/64 (6)	48 (1,219)	9/32 (7)
92.5 (28.194)	48 (1,219)	9/64 (4)	48 (1,219)	3/16 (5)	48 (1,219)	15/64 (6)	48 (1,219)	17/64 (7)
93 (28.346)	48 (1,219)	9/64 (4)	48 (1,219)	3/16 (5)	48 (1,219)	15/64 (6)	48 (1,219)	17/64 (7)
93.5 (28.499)	48 (1,219)	9/64 (4)	48 (1,219)	3/16 (5)	48 (1,219)	15/64 (6)	48 (1,219)	17/64 (7)
94 (28.651)	48 (1,219)	9/64 (4)	48 (1,219)	3/16 (5)	48 (1,219)	7/32 (6)	48 (1,219)	17/64 (7)
94.5 (28.804)	48 (1,219)	9/64 (4)	48 (1,219)	3/16 (5)	48 (1,219)	7/32 (6)	48 (1,219)	17/64 (7)
95 (28.956)	48 (1,219)	9/64 (4)	48 (1,219)	3/16 (5)	48 (1,219)	7/32 (6)	48 (1,219)	17/64 (7)
95.5 (29.108)	48 (1,219)	9/64 (4)	48 (1,219)	3/16 (5)	48 (1,219)	7/32 (6)	48 (1,219)	17/64 (7)
96 (29.261)	48 (1,219)	9/64 (4)	48 (1,219)	3/16 (5)	48 (1,219)	7/32 (6)	48 (1,219)	17/64 (7)
96.5 (29.413)	48 (1,219)	9/64 (4)	48 (1,219)	3/16 (5)	48 (1,219)	7/32 (6)	48 (1,219)	17/64 (7)
97 (29.566)	48 (1,219)	9/64 (4)	48 (1,219)	3/16 (5)	48 (1,219)	7/32 (6)	48 (1,219)	17/64 (7)
97.5 (29.718)	48 (1,219)	9/64 (4)	48 (1,219)	3/16 (5)	48 (1,219)	7/32 (6)	48 (1,219)	17/64 (7)
98 (29.870)	48 (1,219)	9/64 (4)	48 (1,219)	3/16 (5)	48 (1,219)	7/32 (6)	48 (1,219)	1/4 (6)
98.5 (30.023)	48 (1,219)	9/64 (4)	48 (1,219)	11/64 (4)	48 (1,219)	7/32 (6)	48 (1,219)	1/4 (6)
99 (30.175)	48 (1,219)	1/8 (3)	48 (1,219)	11/64 (4)	48 (1,219)	7/32 (6)	48 (1,219)	1/4 (6)
99.5 (30.328)	48 (1,219)	1/8 (3)	48 (1,219)	11/64 (4)	48 (1,219)	7/32 (6)	48 (1,219)	1/4 (6)
100 (30.480)	48 (1,219)	1/8 (3)	48 (1,219)	11/64 (4)	48 (1,219)	7/32 (6)	48 (1,219)	1/4 (6)

INSTALLATION GUIDE

<b>Good. Solid. Green.™</b>	<a href="http://www.logixicf.com">www.logixicf.com</a>	<b>LOGIX®</b> <small>INSULATED CONCRETE FORMS</small>
2-107		

REPRINTED 2011

## 2.21 – TALL WALLS



LOGIX walls can be constructed to any height provided proper engineering and construction methods are used.

LOGIX tall walls should be designed in accordance with ACI 318 or CAN/CSA A23.3.

Constructing tall walls follows the same basic steps described throughout Section 2. In addition, building taller walls is done in much the same way as concrete pours using traditional formwork. Generally, LOGIX blocks are stacked and braced, normally 10 to 12 feet high. The concrete is then placed. After the concrete sets LOGIX blocks are then stacked another 10 to 12 feet, and bracing is raised or extended higher to support the wall, as well as keeping the wall plumb. This process is continued until the specified wall height is reached.



To ensure a smooth build, the following items should be considered:

- Load tables in **Section 6** can be used as a design aid for both the builder and designer. However, tall wall designs should be reviewed and approved by a local licensed professional engineer.
- In higher wind areas taller walls may require guy wires for additional support.
- Proper consolidation of concrete can be achieved by adequate vibrating. However, depending on the drop height, and the steel congestion, external vibration should be considered. External vibration should be applied to at least the corners, around openings, and congested areas of rebar. (External



## 2.21 – TALL WALLS CONTINUED

vibrators made specifically for ICFs are available. See **Section 2.23, Supporting Products**).

- Since tall walls are typically poured using a pump truck, using a reducing hose can provide better control of the concrete pour.
- Roughen the surface of all cold joints to ensure a good bond between the surface of the old pour and the subsequent pour. In addition, ensure adequate rebar embedments are provided.
- For the final stage of the pour, use LOGIX Taper Top blocks for the top course of the wall. This provides a larger opening for concrete to flow into the wall and also provides a larger bearing area for supporting elements.
- Several tall wall bracing and alignment systems are available. For more information see **Section 3.2, Tall Wall Bracing Systems**.

**NOTE:** Both ACI 318 and CAN/CSA A23.3 permit cold joints when concrete is poured in stages.

## 2.22 – TILT-UP WALL CONSTRUCTION

The LOGIX KD panels can provide insulation to the exterior, interior or both sides of tilt-up wall panels.

The use of LOGIX KD to insulate tilt-up walls avoids the need to finish the concrete surface and apply curing and finishing compounds.

Casting of tilt-up walls in cold weather is also possible with LOGIX KD since the walls are thermally protected within the panels.

In addition, the structural design and connections of supporting elements are not affected by the use of LOGIX KD.

### CAST AGAINST LOGIX KD

Provided LOGIX KD panels are laid upon a firm level surface, tilt-up wall panels can be cast against LOGIX KD without the need for a casting bed or slab. Release agents are also not required since the walls are poured on top of the LOGIX KD panels.

**STEP 1:** After the formwork for the tilt-up walls have been placed, lay down the LOGIX KD panels within the formwork area before placing the rebar and concrete.

The formwork should be built high enough to accommodate the thickness of the KD panels and the tilt-up wall. Cover as much of the area within the formwork as required (for full insulation cover

## 2.22 – TILT-UP WALL CONSTRUCTION

CONTINUED

lay down the KD panels to cover the entire area within the formwork).

The LOGIX KD panels should be placed in a stack bond pattern with the holding points facing up. This will ensure the holding points will be properly anchored into the concrete during the pour.

Create cutouts in the LOGIX KD panels where inserts will be placed for bracing.

**STEP 2:** Place the rebar and inserts for lifting or bracing. Pour the concrete, finish and cure the walls as required.

**STEP 3:** Once the all the tilt-up panels have been erected and braces removed, replace all cutout sections of LOGIX KD panels with similar foam insulation (or insulation with equal or greater R-value).

Apply spray foam between LOGIX KD panel joints if necessary.

**STEP 4:** Apply interior or exterior finish to the LOGIX KD panels as required.

## 2.22 – TILT-UP WALL CONSTRUCTION

CONTINUED

### WET SETTING LOGIX

Wet setting LOGIX eliminates the need to trowel finish, and apply finishing and curing compounds.

**STEP 1:** To prepare the LOGIX KD panels for wet setting, lay the panels on a flat surface with the holding points facing down. Keep the LOGIX KD panels slightly elevated from the ground to avoid damaging the holding points. Lay the LOGIX KD panels in a stack bond pattern and connect the panels together with a metal strongback or 2x4s. Connect the strongback or 2x4s along the embedded furring tabs with wood screws.

**STEP 2:** Once the concrete for the tilt-up wall panels have been placed and properly screed, the LOGIX KD panels can be wet set into place.

The LOGIX KD panels can be wet set by holding onto the strongbacks or 2x4s. Once the LOGIX KD panels are in place press down firmly to ensure the holding points are properly embedded into the concrete.

Smaller cut pieces of LOGIX KD panels can be wet set by hand to fill in any remaining areas of the formed wall.

The number of LOGIX KD panels should be determined ahead of time, assembled and ready for placement.

## 2.22 – TILT-UP WALL CONSTRUCTION

CONTINUED

**STEP 3:** Use a vibrator to along the strongbacks or 2x4s to properly consolidate the concrete.

**STEP 4:** Remove the strongbacks or 2x4s after the concrete has set.

**STEP 5:** After the walls are lifted and placed foam spray the joints between the LOGIX KD panels.

**STEP 6:** Apply interior or exterior finish to the LOGIX KD panels as required.

### LOGIX KD PANELS ON BOTH SIDES OF WALL

To apply LOGIX KD panels to both sides of tilt-up walls simply follow the instructions for casting walls against LOGIX KD panels and wet setting LOGIX KD panels on tilt-up walls.

## 2.23 – SUPPORTING PRODUCTS

A list of supporting ICF products are shown below. Consult with the listed manufacturer prior to using with LOGIX Insulated Concrete Forms. Please note: the products listed below does not prohibit the use of LOGIX ICFs with other supporting products not listed.

### FOOTINGS

Product Name	Manufacturer	Contact	Website
Fastfoot	Fab-form Industries	1-888-303-3278	fab-form.com
Form-A-Drain	CertainTeed Corp.	708-301-4449	certainteed.com
Footing Tube	Footing Tube	1-888-929-2011	foottube.com

### EXTERIOR FINISHES

Product Name	Manufacturer	Contact	Website
Durock	Alfacing International Ltd.	1-888-238-6345	durock.com
Senerflex	Degussa Wall Systems, Inc.	1-800-221-9255	senergy.cc
Sto EIFS System	Sto Corp.	1-800-221-2397	stocorp.com
GrailCoat	GrailCoat	1-877-472-4528	grailcoat.com
TAFS (Textured Acrylic Finishes)	dryvit	1-800-263-3308	dryvit.com
SoftCoat PB System	Total Wall, Inc.	1-888-702-9915	totalwall.com
Akroflex	Omega Products Corp.	602-721-5027	omega-products.com
Impact System	parex	1-800-537-2739	parex.com
PermaCrete	Quality Systems	1-800-607-3762	permacrete.com
Crack Guard	Poly-Wall	1-800-846-3020	poly-wall.com
Protecto Bond	Protecto Wrap	1-800-759-9727	protecwrap.com
WeatherWall Systems	Eco Specialty Products Ltd.	1-888-481-5507	ecocoatings.ca

### WATERPROOFING

Product Name	Manufacturer	Contact	Website
System III	Epro	1-800-882-1896	eproserv.com
Blueskin WP2000	Bakor, Inc	1-800-387-9598	bakor.com
Colphene 3000	Soprema, Inc	1-800 567-1492	soprema.com
Delta-MS Clear	Cosella-Dorken Products, Inc.	1-888-4DELTA4	cosella-dorken.com
Platon	Armtec Ltd.	1-800-265-7622	systemplaton.com
Tamko TW60	Tamko, Inc.	1-800-641-4691	tamko.com
Grace waterproofing products	Grace Construction Products	See website	graceconstruction.com
Aqua-Wrap/Green Sheild	Aqua Seal Inc.	1-888-282-3861	aquasealusa.com

### CONNECTION SYSTEMS

Product Name	Manufacturer	Contact	Website
ICF Ledger Connector System	Simpson Strong-Tie Co., Inc.	1-800-999-5099	simpsonstrongtie.com
McMillan Joist Hanger	New Tech Concrete Solutions	1-888-835-6655	-
ICF-Connect	ICF-Connect Ltd.	1-866-497-1576	icfconnect.com

## 2.23 – SUPPORTING PRODUCTS CONTINUED

### BUCK SYSTEMS

Product Name	Manufacturer	Contact	Website
VBuck	Vinyl Technologies, Inc.	1-888-578-2825	vbuck.com

### ADHESIVE & SEALANTS

Product Name	Manufacturer	Contact	Website
Enerfoam Sealant/Enerbond Adhesive	Dow Chemical Company	1-800-800-FOAM	dow.com/buildingproducts

### WALL BRACING & ALIGNMENT SYSTEMS

Product Name	Manufacturer	Contact	Website
Giraffe Bracing	Giraffe Bracing	1-888-778-2285	www.giraffebracing.com
Plumwall	Plumwall Ltd.	1-905-786-7586	www.plumwall.com
Mono-Brace	Tapco	814-336-6549	www.mono-brace.com
Amazing Brace	Lakeland Group	905-372-7413	www.lakeland-multitrade.com

### EXTERNAL VIBRATORS

Product Name	Manufacturer	Contact	Website
Brecon	Brecon Inc.	815-463-8073	http://icfvibrator.com
Arkie Wall Banger	Available from Wind-lock	1-800-872-5625	-

### SUPPLIERS OF SUPPORTING ICF PRODUCTS

Company	Contact	Website
Wind-lock	1-800-872-5625	wind-lock.com
Grace Construction Products	See website	graceconstruction.com

