

REVISIONS			
REV	DESCRIPTION	DATE	APPROVED
B	REVISED PER NEW REQUIREMENTS	01/04/18	R.L.

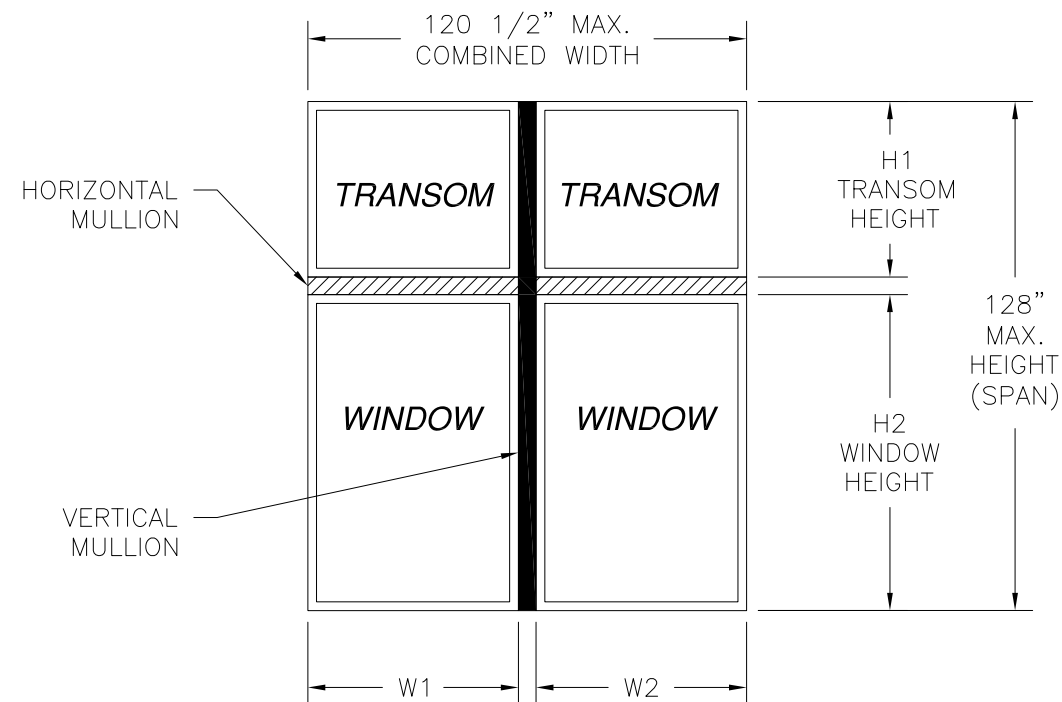

10300085 ALUMINUM X MULLION
NON REINFORCED IMPACT UP TO WIND ZONE 3

Maximum design pressure chart (psf)
Design Pressures are Positive and Negative

Mullion span (in)	Tributary Height (in)	Tributary width (in)									
		24.00	28.00	32.00	36.00	40.00	44.00	48.00	52.00	54.00	60.00
48.00	24.00	135.3	121.8	110.7	101.5	93.7	87.0	81.2	76.1	73.8	67.7
56.00	28.00	110.7	99.4	90.8	83.5	77.3	72.0	67.4	63.3	61.4	56.4
64.00	32.00	93.7	83.5	76.1	68.8	62.8	57.8	53.5	49.8	48.2	43.8
72.00	36.00	67.7	59.0	52.5	47.5	43.4	40.0	37.1	34.6	33.4	30.4
80.00	40.00	48.9	42.5	37.8	34.1	31.2	28.7	26.7	24.9	24.1	21.9
88.00	44.00	36.4	31.6	28.1	25.3	23.1	21.3	19.8	18.5	17.9	16.3
96.00	48.00	27.9	24.2	21.4	19.3	17.6	16.2	15.0	-	-	-
104.00	52.00	21.8	18.9	16.7	15.0	-	-	-	-	-	-
112.00	56.00	17.4	15.0	-	-	-	-	-	-	-	-

NOTES:

1. THE PRODUCT SHOWN HEREIN IS DESIGNED AND MANUFACTURED TO COMPLY WITH REQUIREMENTS OF THE FLORIDA BUILDING CODE.
2. WOOD FRAMING AND MASONRY OPENING TO BE DESIGNED AND ANCHORED TO PROPERLY TRANSFER ALL LOADS TO STRUCTURE. FRAMING AND MASONRY OPENING IS THE RESPONSIBILITY OF THE ARCHITECT OR ENGINEER OF RECORD.
3. ALLOWABLE STRESS INCREASE OF 1/3 WAS NOT USED IN THE DESIGN OF THE PRODUCT SHOWN HEREIN. WIND LOAD DURATION FACTOR Cd=1.6 WAS USED FOR WOOD ANCHOR CALCULATIONS.
4. APPROVED IMPACT PROTECTIVE SYSTEM IS NOT REQUIRED FOR THIS PRODUCT IN WIND BORNE DEBRIS REGIONS
5. DESIGN PRESSURE AND INSTALLATION DETAILS SHOWN IN THIS DOCUMENT APPLY ONLY TO THE MULLION. WINDOWS MUST BE APPROVED UNDER SEPARATE APPROVAL.
6. SINGLE UNITS TO BE MULLED ARE NOT LIMITED TO THOSE SHOWN IN THIS DRAWING. SINGLE UNITS TO BE MULLED TOGETHER MUST BE MANUFACTURED BY STERGIS WINDOWS & DOORS, INC.
7. DESIGN PRESSURE OF MULLED UNIT SHALL BE CONTROLLED BY THE LESSER DESIGN PRESSURE OF THE MULLION OR THE INDIVIDUAL WINDOW UNIT.
8. UNITS MAY BE MULLED INDEFINITELY.

DESIGN PRESSURE TABLE INSTRUCTIONS:

1. DEFINE REQUIRED DESIGN LOAD PER FLORIDA BUILDING CODE CHAPTER 16.
2. DETERMINE TRIBUTARY WIDTH, HEIGHT AND MULLION SPAN BASED ON PRODUCT TO BE INSTALLED. SEE FORMULA FOR TRIBUTARY WIDTH AND HEIGHT.
3. LOCATE MULLION SPAN (UNIT HEIGHT) AND TRIBUTARY WIDTH. AT THE INTERSECTION OF ROW AND COLUMN CONTAINING THE MULLION SPAN AND TRIBUTARY WIDTH RESPECTIVELY IS THE MULLION RATING FOR PRODUCT IN STEP 2. MULLION RATING MUST BE EQUAL OR GREATER THAN REQUIRED DESIGN PRESSURE OBTAINED IN STEP 1.

$$\text{TRIBUTARY HEIGHT} = \frac{H1 + H2}{2}$$

$$\text{TRIBUTARY WIDTH} = \frac{W1 + W2}{2}$$

SIGNED: 01/08/2018

TABLE OF CONTENTS	
SHEET NO.	DESCRIPTION
1	ELEVATIONS, NOTES AND DESIGN PRESSURE CHART
2, 3	INSTALLATION DETAILS AND BILL OF MATERIALS
4	COMPONENTS

STERGIS WINDOWS & DOORS, INC.
 79 WALTON ST
 ATTLEBORO, MA 02703

10300085 ALUMINUM X MULLION
 NON-REINFORCED IMPACT
 ELEVATIONS, NOTES AND DESIGN PRESSURE CHART

DRAWN: TJH DWG NO. 08-01238 REV B

SCALE NTS DATE 04/26/11 SHEET 1 OF 4

L. ROBERTO LOMAS P.E.
 1432 WOODFORD RD LEWISVILLE, NC 27023
 434-688-0609 rllomas@rlomaspe.com

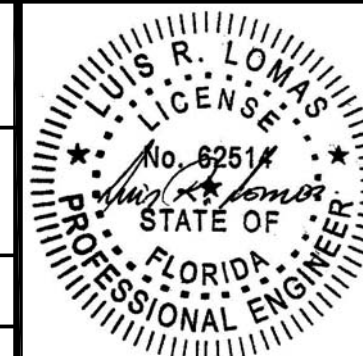

Luis R. Lomas P.E.
 FL No.: 62514

PARTS LIST				
NO.	PART NUMBER	DESCRIPTION	MANUFACTURER	MATERIAL
1	10300085	ALUMINUM VERTICAL MULLION	DECEUNINCK	ALUMINUM 6005-T5
2	10203000	15GA. STEEL MULLION BRACKET	DECEUNINCK	GALVANIZED STEEL
3	10300093	MULL CLIP	DECEUNINCK	ALUMINUM 6005-T5

REVISIONS			
REV	DESCRIPTION	DATE	APPROVED
B	REVISED PER NEW REQUIREMENTS	01/04/18	R.L.

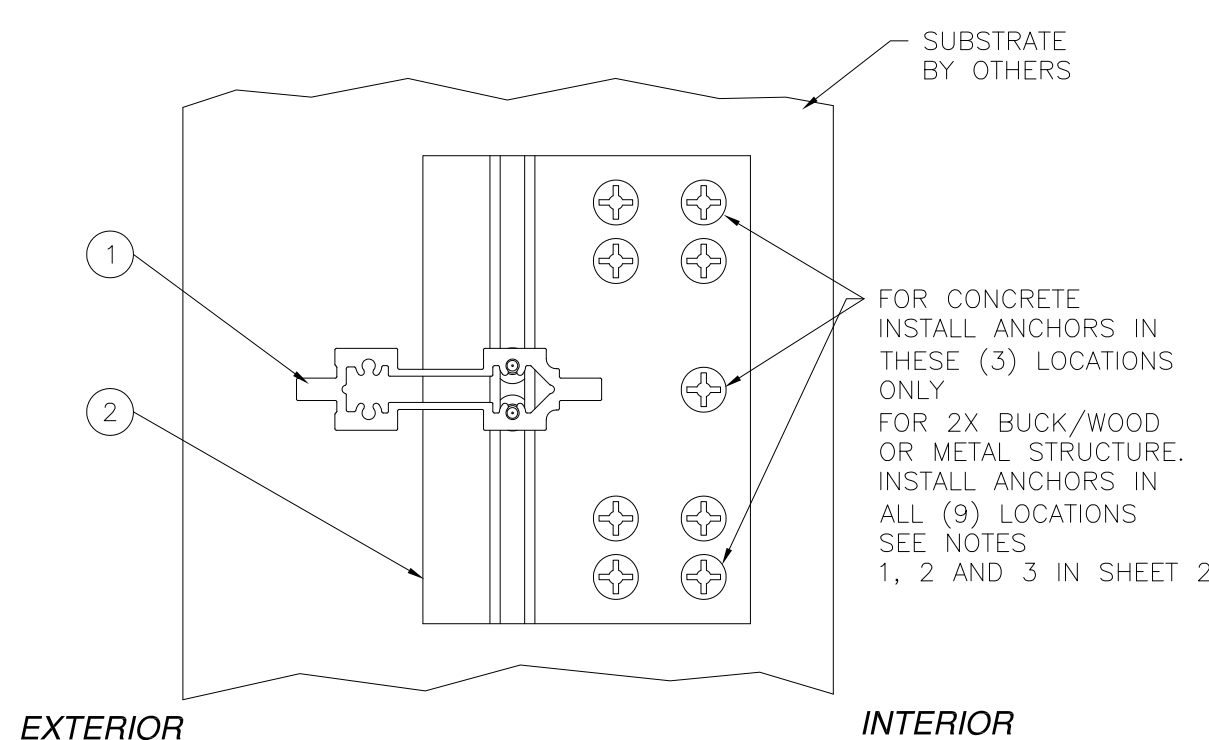

- ANCHORING NOTES:
- 1) FOR ANCHORING MULLION BRACKET OR MULL CLIP INTO MASONRY/CONCRETE USE 3/16" ITW TAPCONS WITH SUFFICIENT LENGTH TO ACHIEVE A 1 3/4" MINIMUM EMBEDMENT INTO SUBSTRATE WITH 2 1/2" MINIMUM EDGE DISTANCE. LOCATE ANCHORS AS SHOWN IN ELEVATIONS AND INSTALLATION DETAILS.
 - 2) FOR ANCHORING MULLION BRACKET OR MULL CLIP INTO WOOD FRAMING OR 2X BUCK USE #10 WOOD SCREW WITH SUFFICIENT LENGTH TO ACHIEVE A 1 3/8" MINIMUM EMBEDMENT INTO SUBSTRATE. WITH 1/2" MINIMUM EDGE DISTANCE. LOCATE ANCHORS AS SHOWN IN ELEVATIONS AND INSTALLATION DETAILS.
 - 3) FOR ANCHORING MULLION BRACKET OR MULL CLIP INTO 16GA. MINIMUM METAL FRAMING USE #10 SELF TAPPING SCREWS WITH SUFFICIENT LENGTH TO ACHIEVE A MINIMUM EMBEDMENT OF THREE THREADS PAST SUBSTRATE. WITH 3/4" MINIMUM EDGE DISTANCE. LOCATE ANCHORS AS SHOWN IN ELEVATIONS AND INSTALLATION DETAILS.
 - 4) FOR WINDOW UNIT ANCHORING TO VERTICAL MULLION SEE INDIVIDUAL WINDOW APPROVAL INSTALLATION INSTRUCTIONS.
 - 5) FOR WINDOW UNIT ANCHORING SCHEDULE TO SUBSTRATE REFER TO INDIVIDUAL WINDOW APPROVAL INSTALLATION INSTRUCTIONS.
 - 6) ALL FASTENERS TO BE CORROSION RESISTANT.
 - 7) INSTALLATION ANCHORS SHALL BE INSTALLED IN ACCORDANCE WITH ANCHOR MANUFACTURER'S INSTALLATION INSTRUCTIONS, AND ANCHORS SHALL NOT BE USED IN SUBSTRATES WITH STRENGTHS LESS THAN THE MINIMUM STRENGTH SPECIFIED BELOW:
 - A. WOOD - MINIMUM SPECIFIC GRAVITY OF G=0.42
 - B. CONCRETE - MINIMUM COMPRESSIVE STRENGTH OF 2,000 PSI.
 - C) METAL FRAMING - 16GA. MINIMUM.

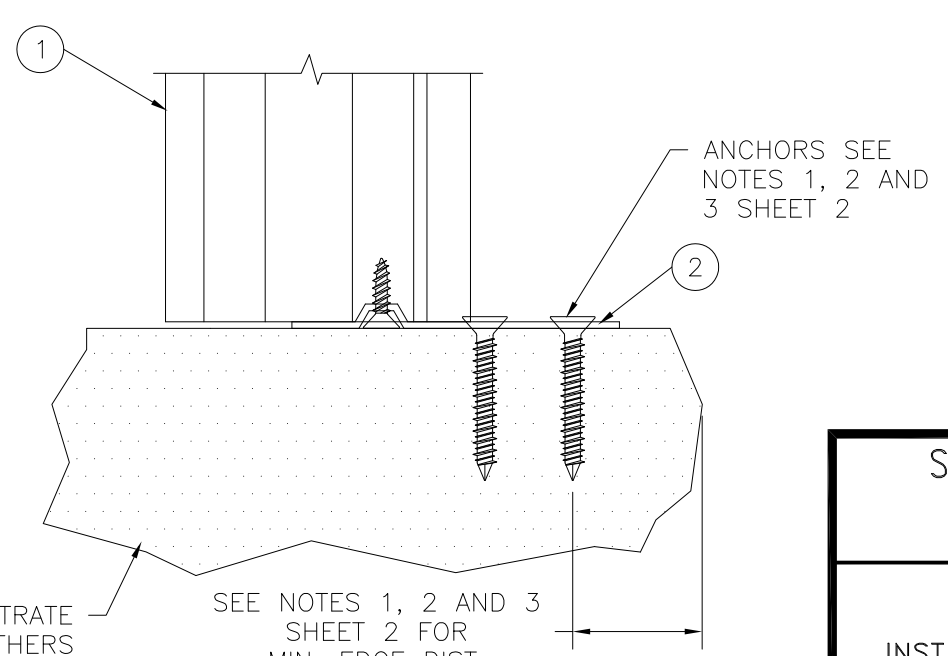
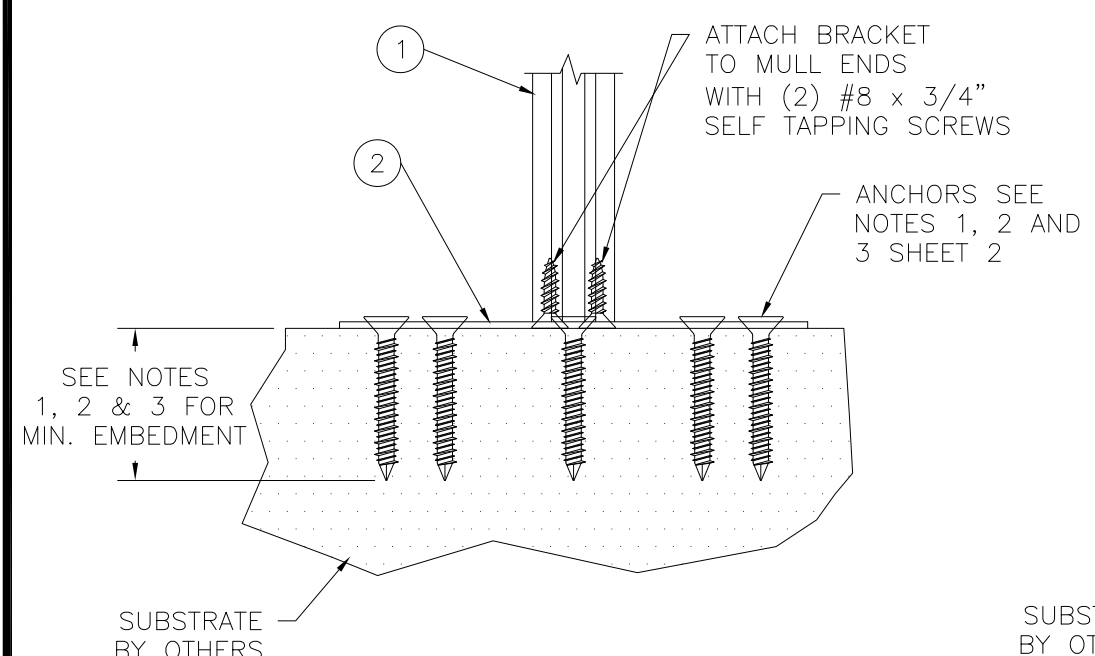

STEEL MULLION BRACKET 10203000
INSTALLATION DETAILS
 SILL, SHOWN, HEAD AND JAMBS SIMILAR

STERGIS WINDOWS & DOORS, INC.
 79 WALTON ST
 ATTLEBORO, MA 02703

10300085 ALUMINUM X MULLION
 NON-REINFORCED IMPACT
 INSTALLATION DETAILS AND BILL OF MATERIALS

DRAWN: TJH	DWG NO. 08-01238	REV B
SCALE NTS	DATE 04/26/11	SHEET 2 OF 4

L. ROBERTO LOMAS P.E.
 1432 WOODFORD RD LEWISVILLE, NC 27023
 434-688-0609 rllomas@rlomaspe.com

SIGNED: 01/08/2018

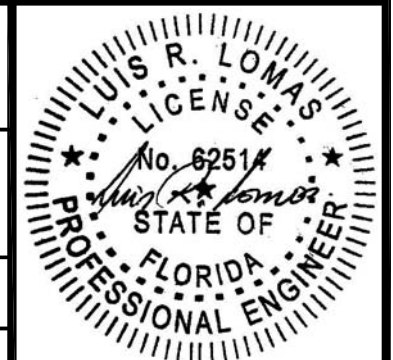

Luis R. Lomas P.E.
 FL No.: 62514

REVISIONS			
REV	DESCRIPTION	DATE	APPROVED
B	REVISED PER NEW REQUIREMENTS	01/04/18	R.L.

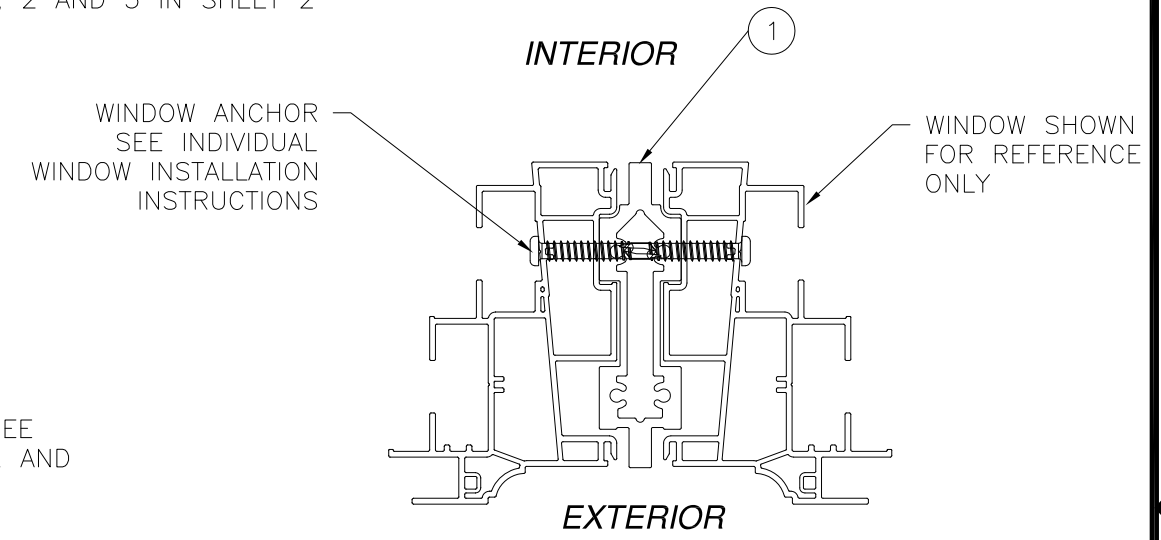
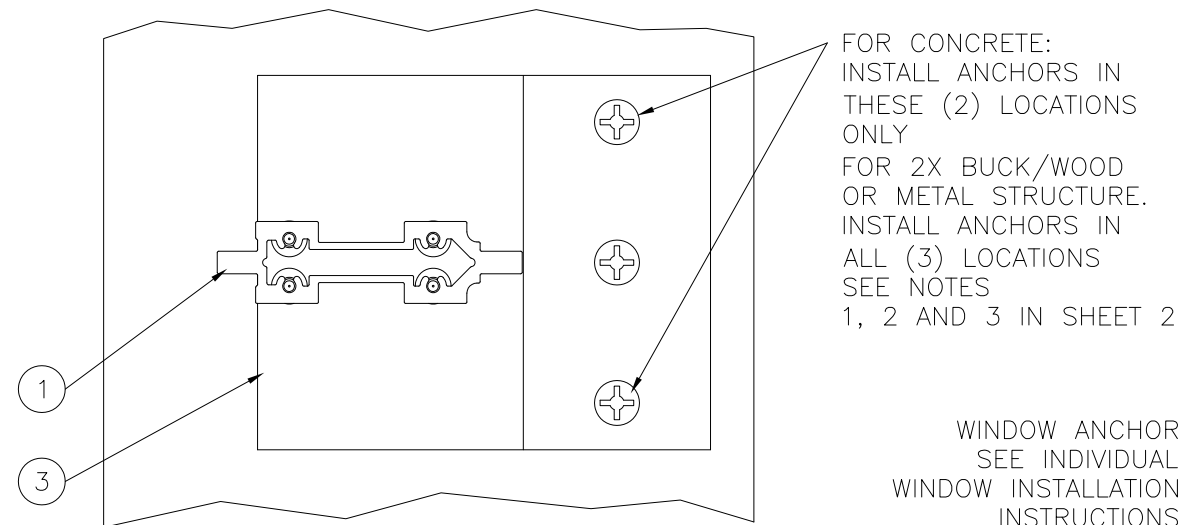

WINDOW TO MULLION INSTALLATION DETAIL

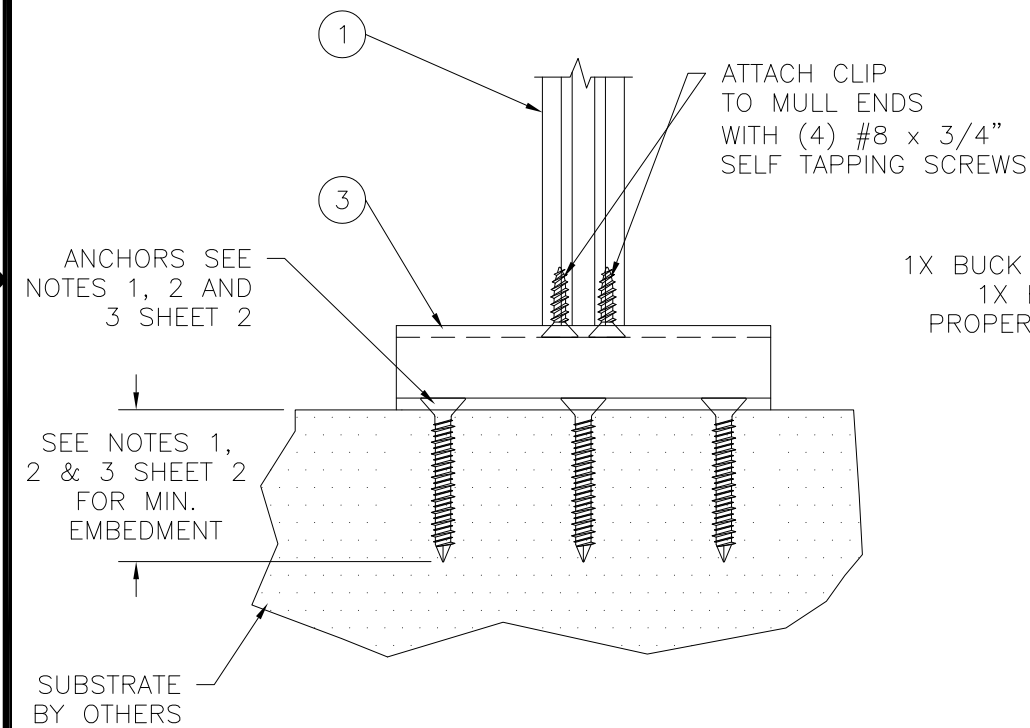

1X BUCK BY OTHERS,
1X BUCK TO BE PROPERLY SECURED

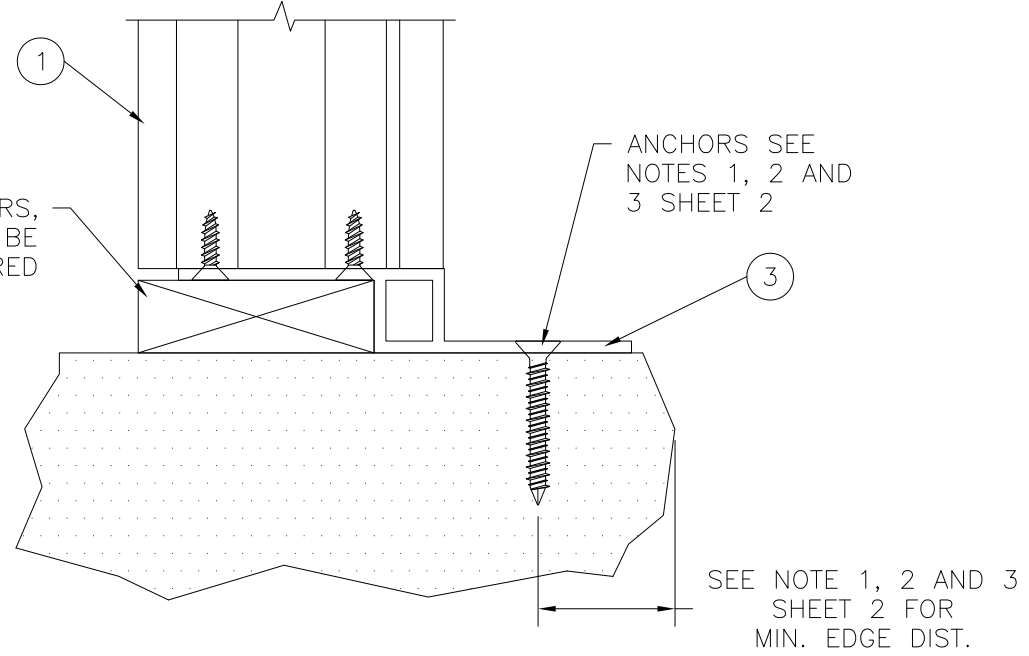

ALTERNATE MULL CLIP 10300093
INSTALLATION DETAILS
SILL, SHOWN, HEAD AND JAMBS SIMILAR

SIGNED: 01/08/2018

STERGIS WINDOWS & DOORS, INC.
79 WALTON ST
ATTLEBORO, MA 02703

10300085 ALUMINUM X MULLION
NON-REINFORCED IMPACT
INSTALLATION DETAILS

DRAWN: TJH	DWG NO. 08-01238	REV B
SCALE NTS	DATE 04/26/11	SHEET 3 OF 4

L. ROBERTO LOMAS P.E.
1432 WOODFORD RD LEWISVILLE, NC 27023
434-688-0609 rllomas@rlomaspe.com

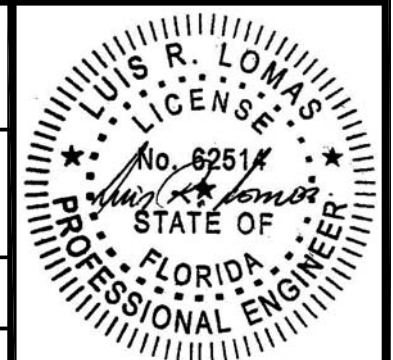

Luis R. Lomas P.E.
FL No.: 62514

REVISIONS			
REV	DESCRIPTION	DATE	APPROVED
B	REVISED PER NEW REQUIREMENTS	01/04/18	R.L.

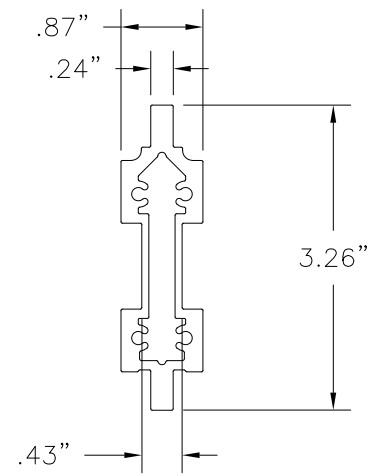

① **10300085 ALUMINUM VERTICAL MULLION**
ALUMINUM 6005-T5 .075" THICK MINIMUM

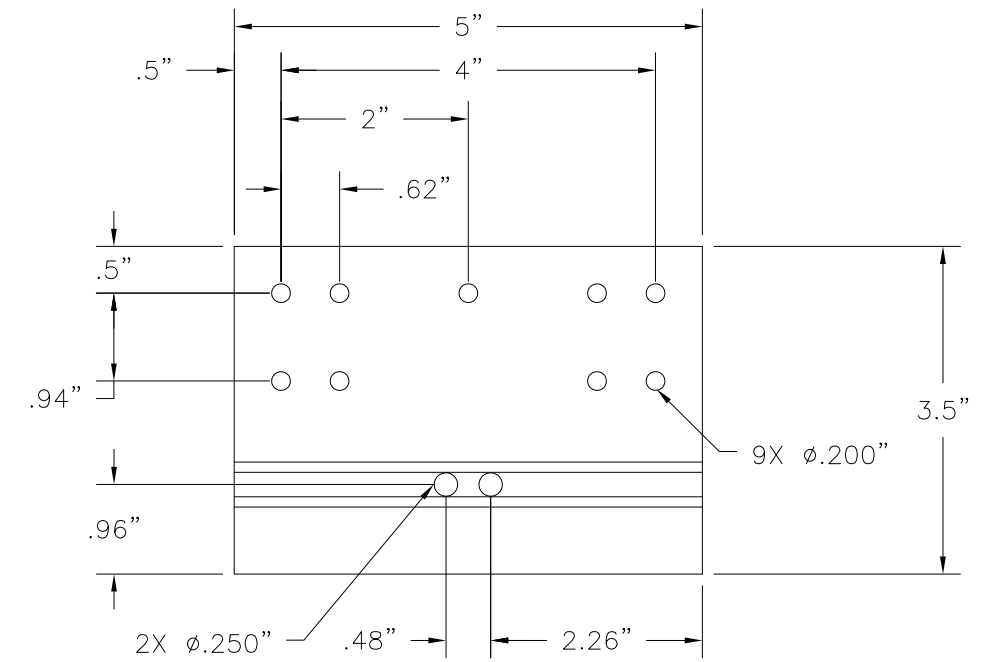

② **STEEL MULLION BRACKET**
15GA. GALVANIZED STEEL

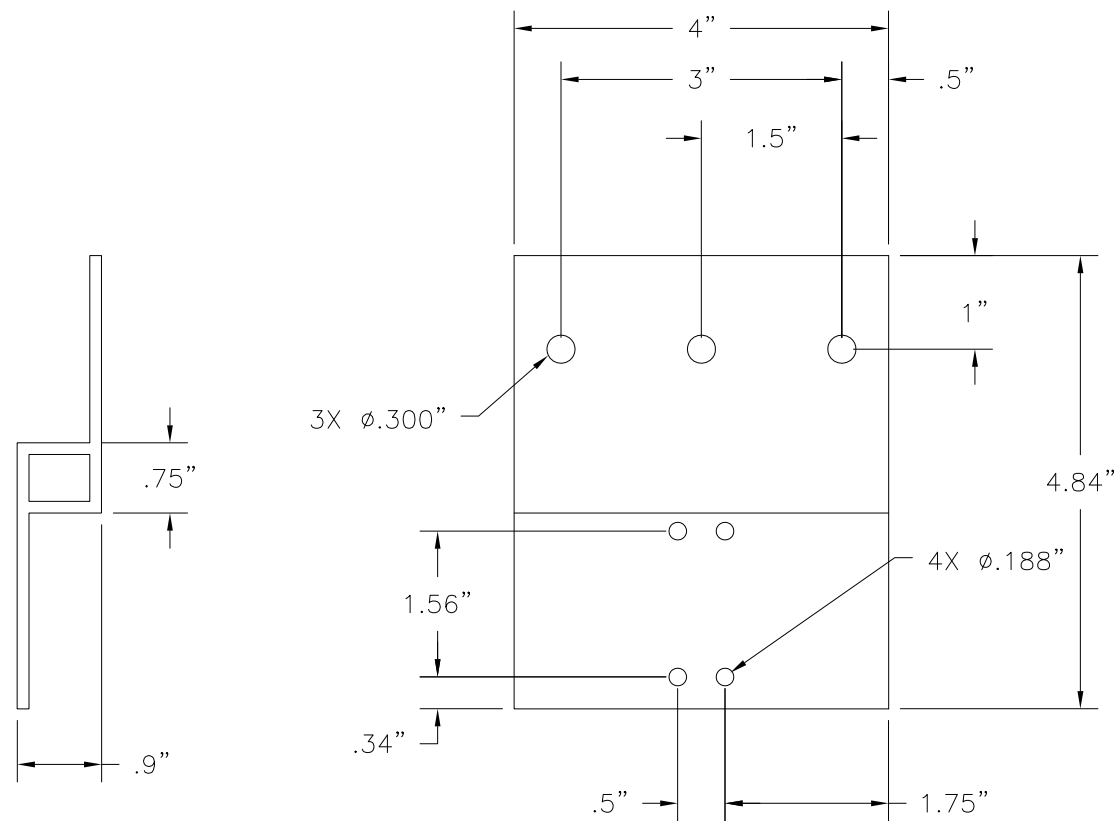

③ **MULL CLIP**
ALUMINUM 6005-T5 .125" THICK

SIGNED: 01/08/2018

STERGIS WINDOWS & DOORS, INC.

79 WALTON ST
ATTLEBORO, MA 02703

10300085 ALUMINUM X MULLION
NON-REINFORCED IMPACT
COMPONENTS

DRAWN: TJH	DWG NO. 08-01238	REV B
SCALE NTS	DATE 04/26/11	SHEET 4 OF 4

L. ROBERTO LOMAS P.E.
1432 WOODFORD RD LEWISVILLE, NC 27023
434-688-0609 rllomas@rlomaspe.com

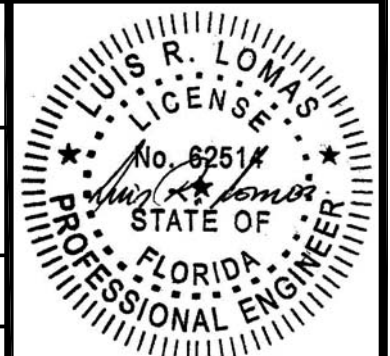

Luis R. Lomas P.E.
FL No.: 62514