

REVISIONS			
REV	DESCRIPTION	DATE	APPROVED
A	REVISED PER NEW REQUIREMENTS	01/09/18	R.L.

NOTES:

1. THE PRODUCT SHOWN HEREIN IS DESIGNED AND MANUFACTURED TO COMPLY WITH REQUIREMENTS OF THE FLORIDA BUILDING CODE INCLUDING THE HVHZ.
2. WOOD FRAMING AND MASONRY OPENING TO BE DESIGNED AND ANCHORED TO PROPERLY TRANSFER ALL LOADS TO STRUCTURE. FRAMING AND MASONRY OPENING IS THE RESPONSIBILITY OF THE ARCHITECT OR ENGINEER OF RECORD.
3. 1X BUCK OVER MASONRY/CONCRETE IS OPTIONAL. WHERE 1X BUCK IS NOT USED DISSIMILAR MATERIALS MUST BE SEPARATED WITH APPROVED COATING OR MEMBRANE. SELECTION OF COATING OR MEMBRANE IS THE RESPONSIBILITY OF THE ARCHITECT OR ENGINEER OF RECORD.
4. ALLOWABLE STRESS INCREASE OF 1/3 WAS NOT USED IN THE DESIGN OF THE PRODUCT SHOWN HEREIN. WIND LOAD DURATION FACTOR Cd=1.6 WAS USED FOR WOOD ANCHOR CALCULATIONS.
5. FRAME MATERIAL: EXTRUDED ALUMINUM 6063-T6.
6. UNITS MUST BE GLAZED PER ASTM E1300-04/09, SEE SHEET 12 FOR GLASS DETAILS.
7. APPROVED IMPACT PROTECTIVE SYSTEM IS NOT REQUIRED FOR THIS PRODUCT IN WIND BORNE DEBRIS REGIONS.
8. SHIM AS REQUIRED AT EACH INSTALLATION ANCHOR WITH LOAD BEARING SHIM. SHIM WHERE SPACE OF 1/16" OR GREATER OCCURS. MAXIMUM ALLOWABLE SHIM STACK TO BE 1/4".
9. FOR ANCHORING INTO WOOD FRAMING OR 2X BUCK USE #14 WOOD SCREWS WITH SUFFICIENT LENGTH TO ACHIEVE A 1 7/16" MINIMUM EMBEDMENT INTO SUBSTRATE. LOCATE ANCHORS AS SHOWN IN ELEVATIONS AND INSTALLATION DETAILS.
10. FOR ANCHORING INTO MASONRY/CONCRETE USE 1/4" TAPCONS WITH SUFFICIENT LENGTH TO ACHIEVE A 1 1/4" MINIMUM EMBEDMENT INTO SUBSTRATE WITH 2" MINIMUM EDGE DISTANCE. LOCATE ANCHORS AS SHOWN IN ELEVATIONS AND INSTALLATION DETAILS.
11. FOR ANCHORING TROUGH FRAME INTO METAL STRUCTURE USE #14 SMS OR SELF DRILLING SCREWS WITH SUFFICIENT LENGTH TO ACHIEVE 3 THREADS MINIMUM BEYOND STRUCTURE INTERIOR WALL. LOCATE ANCHORS AS SHOWN IN ELEVATIONS AND INSTALLATION DETAILS.

12. ALL FASTENERS TO BE CORROSION RESISTANT.
13. INSTALLATION ANCHORS SHALL BE INSTALLED IN ACCORDANCE WITH ANCHOR MANUFACTURER'S INSTALLATION INSTRUCTIONS AND ANCHORS SHALL NOT BE USED IN SUBSTRATES WITH STRENGTHS LESS THAN THE MINIMUM STRENGTH SPECIFIED BELOW:
 - A. WOOD – MINIMUM SPECIFIC GRAVITY OF G=0.42
 - B. CONCRETE – MINIMUM COMPRESSIVE STRENGTH OF 3,192 PSI.
 - C. MASONRY – STRENGTH CONFORMANCE TO ASTM C-90, GRADE N, TYPE 1 (OR GREATER).
 - D. METAL STRUCTURE: STEEL 18GA, 33KSI OR ALUMINUM 6063-T5 .048" THICK MINIMUM

SIGNED: 01/09/2018

TABLE OF CONTENTS	
SHEET NO.	DESCRIPTION
1	NOTES
2	ELEVATION
3 - 12	INSTALLATION DETAILS

			EASTERN ARCHITECTURAL SYSTEMS A DIVISION OF EASTERN METAL SUPPLY 16341 DOMESTIC AVE FORT MYERS, FL 33912 800-432-2204		
SERIES FD8100 ALUMINUM IMPACT RATED SLIDING GLASS DOOR NOTES					
DRAWN:		DWG NO.		REV	
V.L.		08-02672		A	
SCALE NTS		DATE 03/30/15		SHEET 1 OF 12	
L. ROBERTO LOMAS P.E. 1432 WOODFORD RD LEWISVILLE, NC 27023 434-688-0609 rllomas@rlomaspe.com					

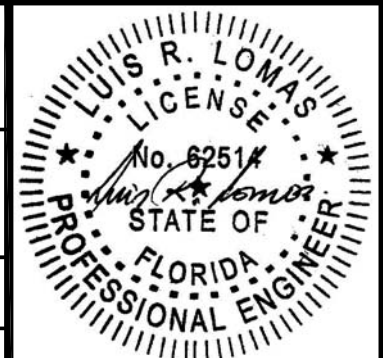

Luis R. Lomas P.E.
FL No.: 62514

REVISIONS			
REV	DESCRIPTION	DATE	APPROVED
A	REVISED PER NEW REQUIREMENTS	01/09/18	R.L.

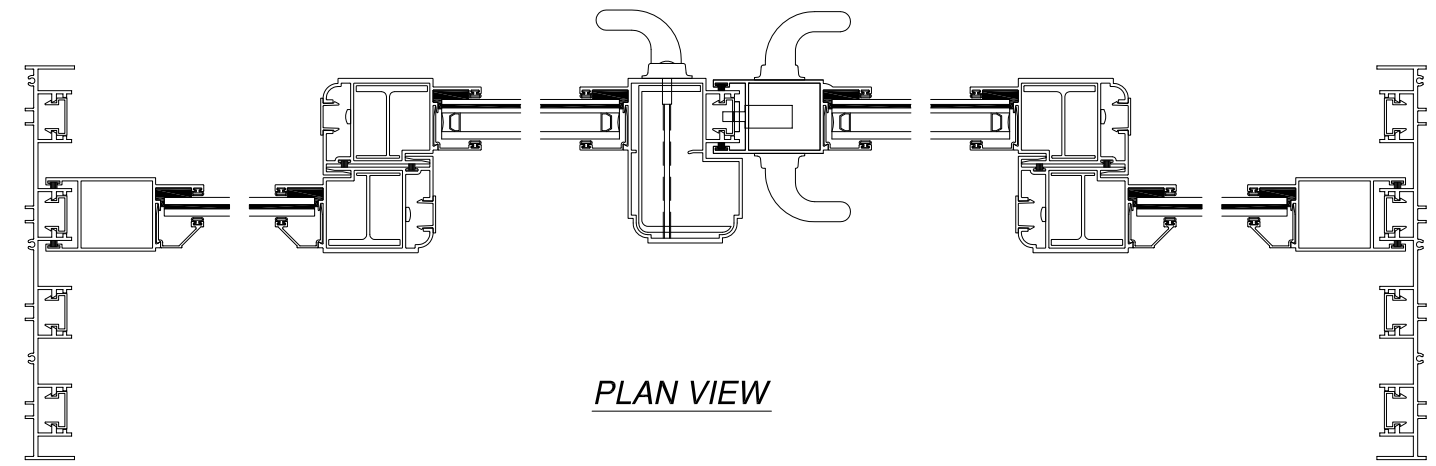

PLAN VIEW

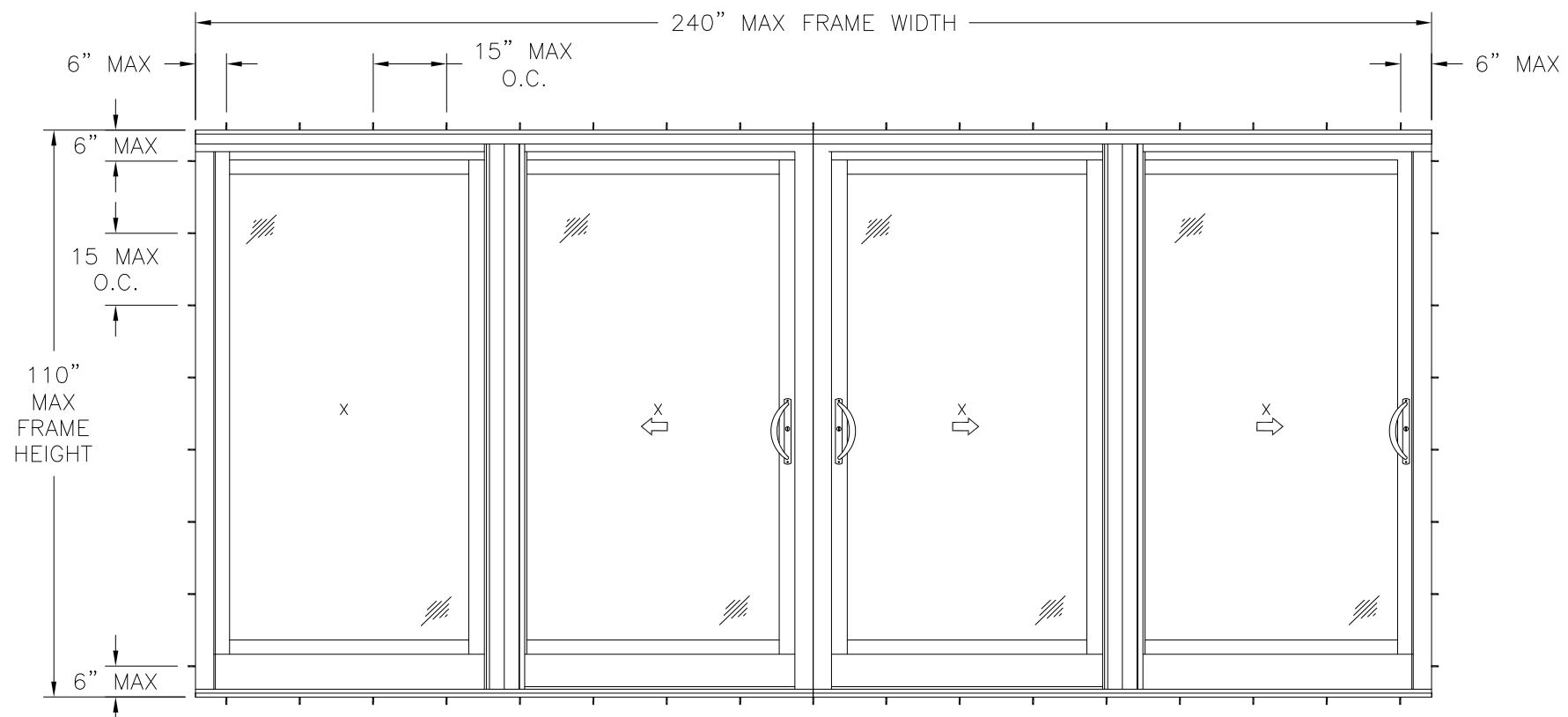

SERIES FD8100 ALUMINUM SLIDING GLASS DOOR - IMPACT
EXTERIOR VIEW

UNITS UP TO 4 PANELS IN UNLIMITED CONFIGURATIONS ARE APPROVED AS LONG AS INDIVIDUAL PANEL AREA DOES NOT EXCEED 45.14 FT²

DESIGN PRESSURE RATING	IMPACT RATING	DESIGN PRESSURE RATING	IMPACT RATING
±50.0PSF	LARGE AND SMALL MISSILE IMPACT	±60.0PSF	LARGE AND SMALL MISSILE IMPACT

MISSILE LEVEL D, WIND ZONE 4 & HVHZ WITH GLAZING A

MISSILE LEVEL D, WIND ZONE 4 & HVHZ WITH GLAZING B & C

NOTES:

- (1) 1" X 3/16" WEEP SLOT 6" FROM EACH END, AND 48" ON CENTER THROUGH VERTICAL SILL LEG EXCEPT MOST INTERIOR SILL LEG.
- MAXIMUM PANEL SIZE: 60 1/8" X 108 1/8"
- MAXIMUM D.L.O.: 52 3/4" X 100 1/4"

SIGNED: 01/09/2018

EASTERN ARCHITECTURAL SYSTEMS
A DIVISION OF
EASTERN METAL SUPPLY
16341 DOMESTIC AVE
FORT MYERS, FL 33912
800-432-2204

SERIES FD8100 ALUMINUM IMPACT RATED SLIDING GLASS DOOR ELEVATION

DRAWN: V.L.	DWG NO. 08-02672	REV A
SCALE NTS	DATE 03/30/15	SHEET 2 OF 12

L. ROBERTO LOMAS P.E.
1432 WOODFORD RD LEWISVILLE, NC 27023
434-688-0609 rllomas@rlomaspe.com

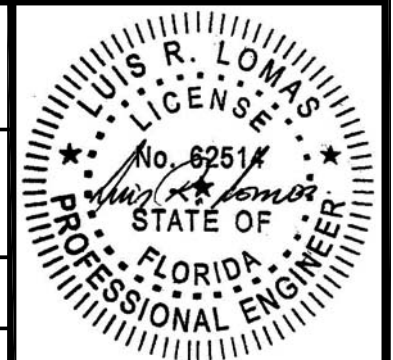

Luis R. Lomas P.E.
FL No.: 62514

HARDWARE SCHEDULE

A.	(1) ADJUSTABLE TANDEM ROLLER ASSEMBLY AT EACH END OF EACH PANEL
B.	(2) 2-POINT MORTISE TYPE LOCKS ON LOCK STILE
C.	(1) MULTI-POINT KEEPERS AT JAMBS AND ASTRAGAL AT LOCK POSITIONS
D.	(1) ALUMINUM REINFORCEMENT AT EACH PANEL INTERLOCK STILE

REVISIONS			
REV	DESCRIPTION	DATE	APPROVED
A	REVISED PER NEW REQUIREMENTS	01/09/18	R.L.

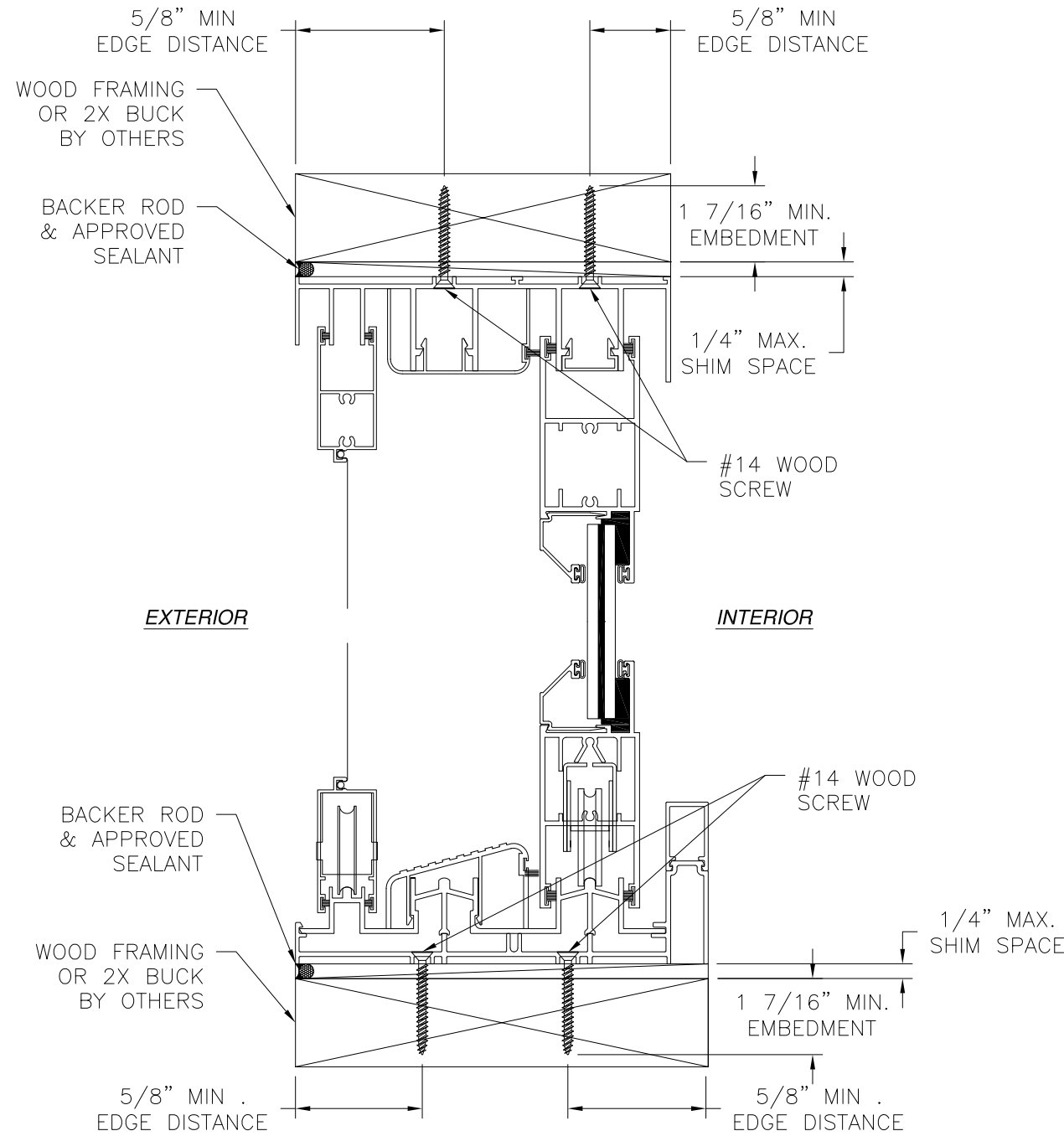

VERTICAL CROSS SECTION
WOOD FRAMING OR 2X BUCK INSTALLATION

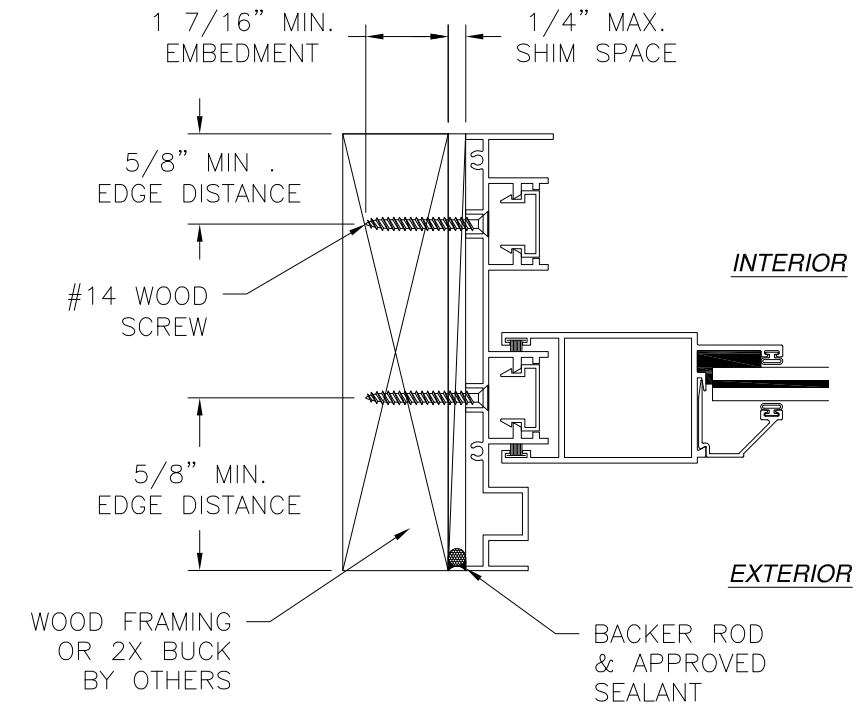

JAMB INSTALLATION DETAIL
WOOD FRAMING OR 2X BUCK INSTALLATION

- NOTES:
1. INTERIOR AND EXTERIOR FINISHES, BY OTHERS, NOT SHOWN FOR CLARITY.
 2. PERIMETER AND JOINT SEALANT BY OTHERS TO BE DESIGNED IN ACCORDANCE WITH ASTM E2112

SIGNED: 01/09/2018

		EASTERN ARCHITECTURAL SYSTEMS A DIVISION OF EASTERN METAL SUPPLY 16341 DOMESTIC AVE FORT MYERS, FL 33912 800-432-2204	
SERIES FD8100 ALUMINUM IMPACT RATED SLIDING GLASS DOOR 2 TRACK INSTALLATION DETAILS			
DRAWN: V.L.	DWG NO. 08-02672	REV A	
SCALE NTS	DATE 03/30/15	SHEET 3 OF 12	
L. ROBERTO LOMAS P.E. 1432 WOODFORD RD LEWISVILLE, NC 27023 434-688-0609 rllomas@rlomaspe.com			

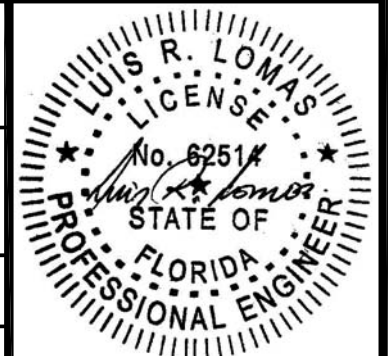

Luis R. Lomas P.E.
FL No.: 62514

REVISIONS			
REV	DESCRIPTION	DATE	APPROVED
A	REVISED PER NEW REQUIREMENTS	01/09/18	R.L.

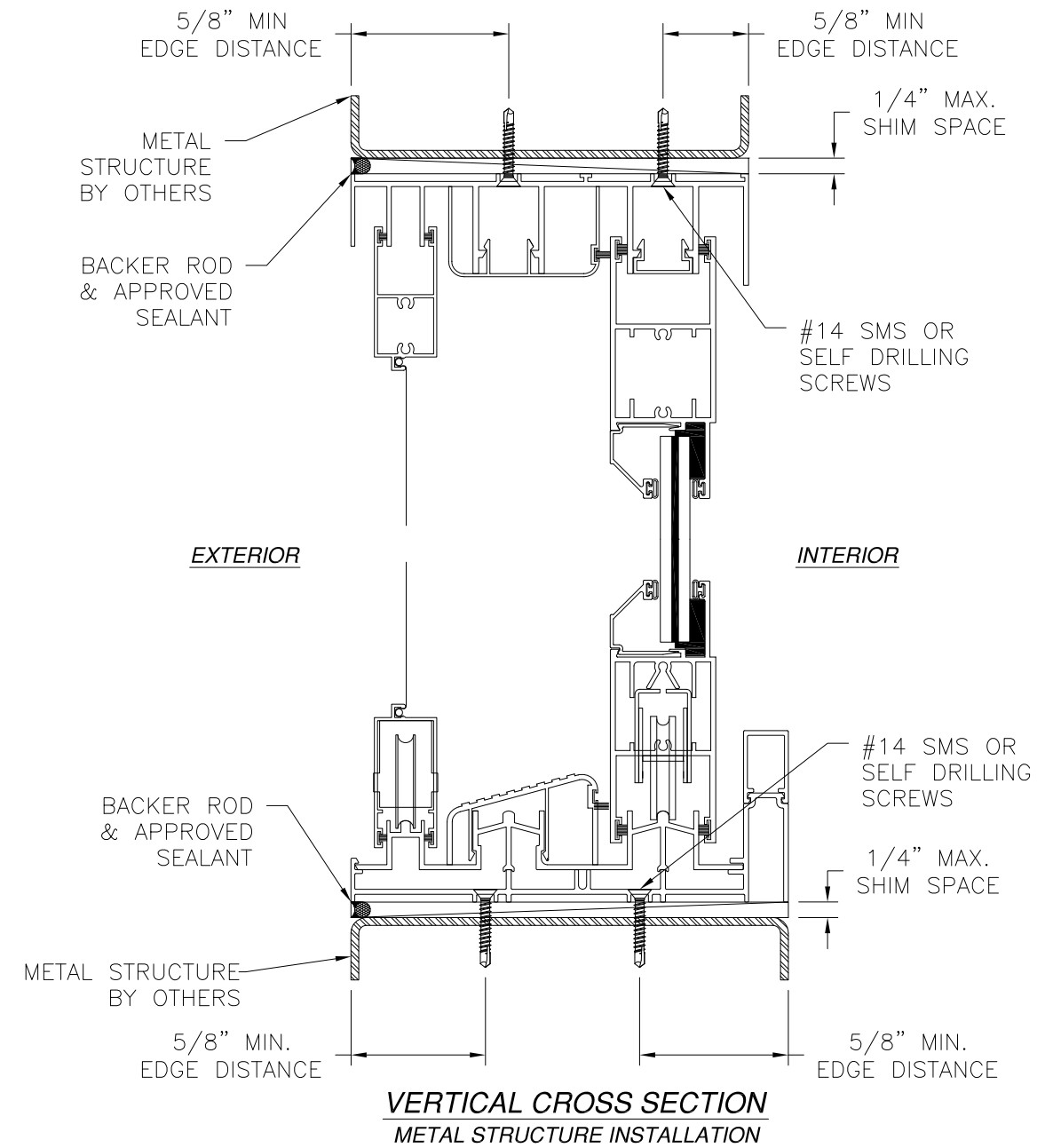

VERTICAL CROSS SECTION
METAL STRUCTURE INSTALLATION

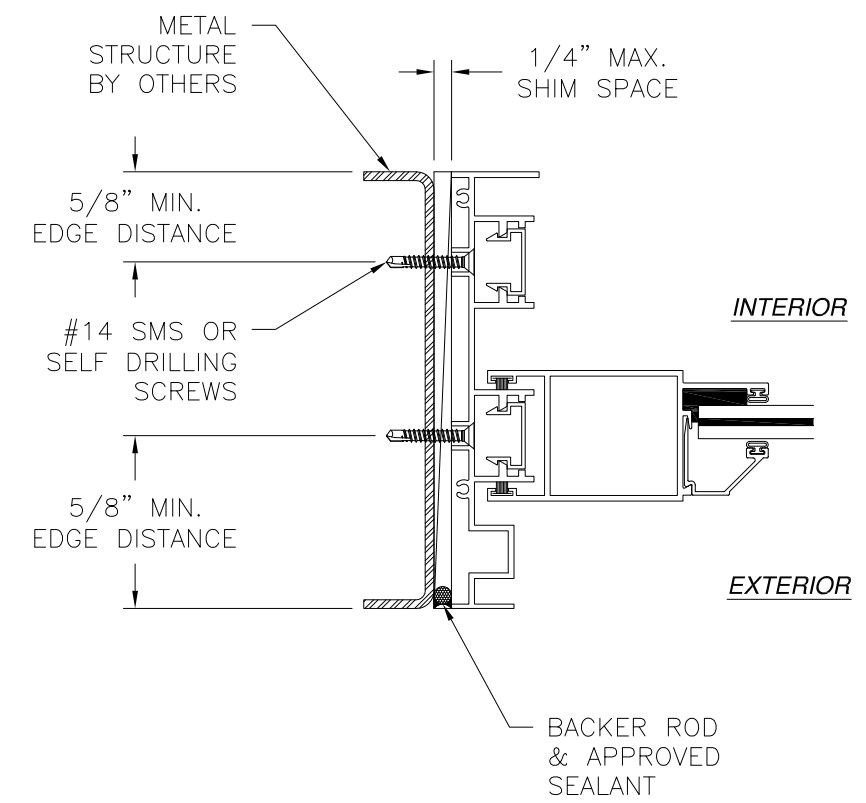

JAMB INSTALLATION DETAIL
METAL STRUCTURE INSTALLATION

NOTES:
 1. INTERIOR AND EXTERIOR FINISHES, BY OTHERS, NOT SHOWN FOR CLARITY.
 2. PERIMETER AND JOINT SEALANT BY OTHERS TO BE DESIGNED IN ACCORDANCE WITH ASTM E2112

SIGNED: 01/09/2018

		EASTERN ARCHITECTURAL SYSTEMS A DIVISION OF EASTERN METAL SUPPLY 16341 DOMESTIC AVE FORT MYERS, FL 33912 800-432-2204	
SERIES FD8100 ALUMINUM IMPACT RATED SLIDING GLASS DOOR 2 TRACK INSTALLATION DETAILS			
DRAWN: V.L.	DWG NO. 08-02672	REV A	
SCALE NTS	DATE 03/30/15	SHEET 4 OF 12	
L. ROBERTO LOMAS P.E. 1432 WOODFORD RD LEWISVILLE, NC 27023 434-688-0609 rllomas@rlomaspe.com			

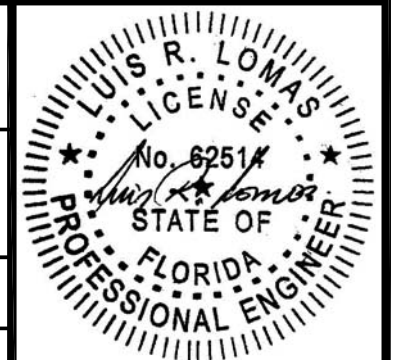

Luis R. Lomas P.E.
FL No.: 62514

REVISIONS			
REV	DESCRIPTION	DATE	APPROVED
A	REVISED PER NEW REQUIREMENTS	01/09/18	R.L.

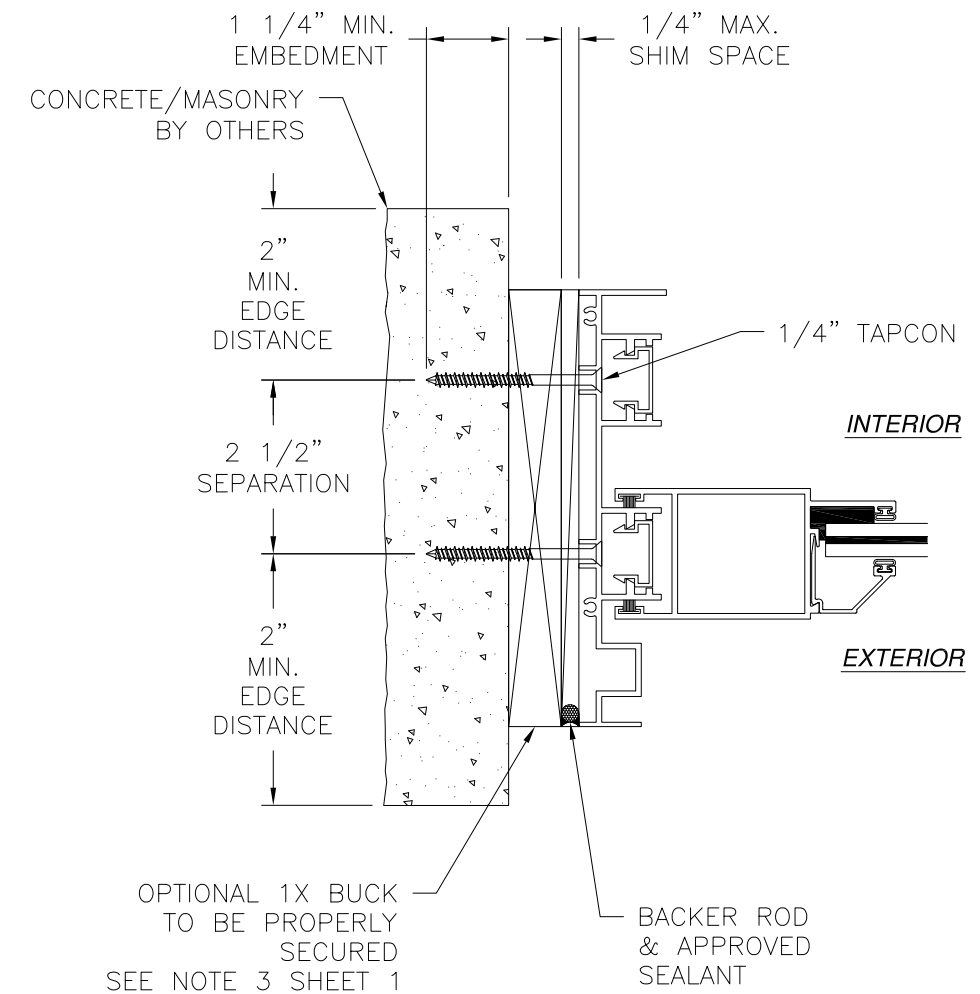
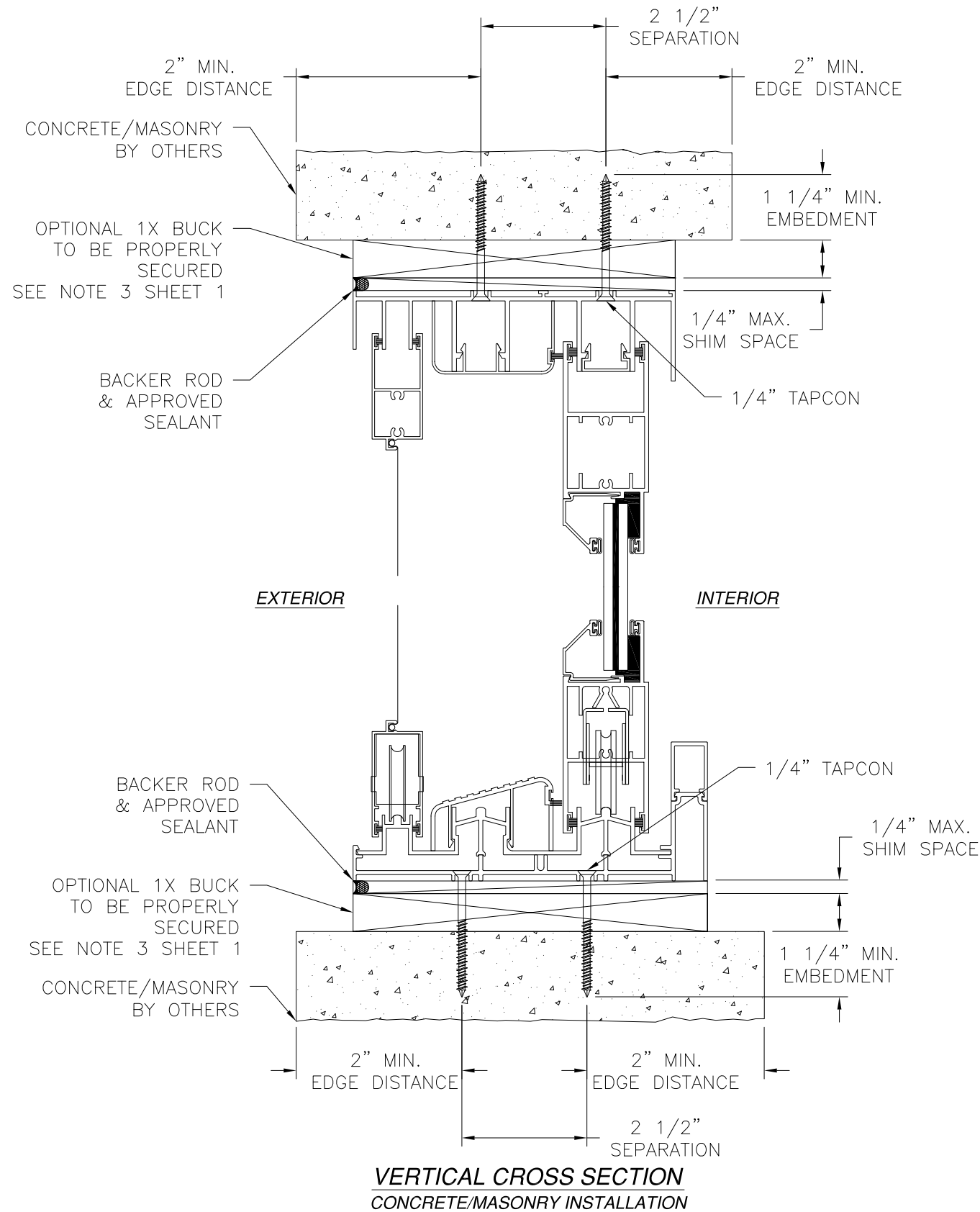

NOTES:
1. INTERIOR AND EXTERIOR FINISHES, BY OTHERS,
NOT SHOWN FOR CLARITY.

SIGNED: 01/09/2018

Eastern ARCHITECTURAL SYSTEMS
ALUMINUM AND VINYL IMPACT WINDOWS AND DOORS
A DIVISION OF EASTERN METAL SUPPLY
16341 DOMESTIC AVE
FORT MYERS, FL 33912
800-432-2204

SERIES FD8100 ALUMINUM IMPACT RATED
SLIDING GLASS DOOR
2 TRACK INSTALLATION DETAILS

DRAWN: V.L.	DWG NO. 08-02672	REV A
SCALE NTS	DATE 03/30/15	SHEET 5 OF 12

L. ROBERTO LOMAS P.E.
1432 WOODFORD RD LEWISVILLE, NC 27023
434-688-0609 rllomas@rlomaspe.com

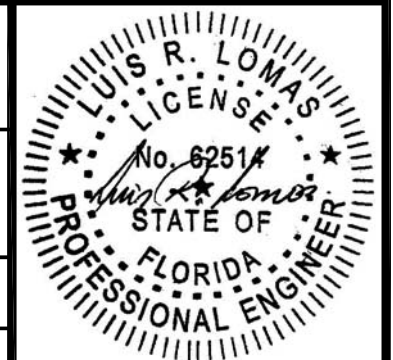

Luis R. Lomas P.E.
FL No.: 62514

REVISIONS			
REV	DESCRIPTION	DATE	APPROVED
A	REVISED PER NEW REQUIREMENTS	01/09/18	R.L.

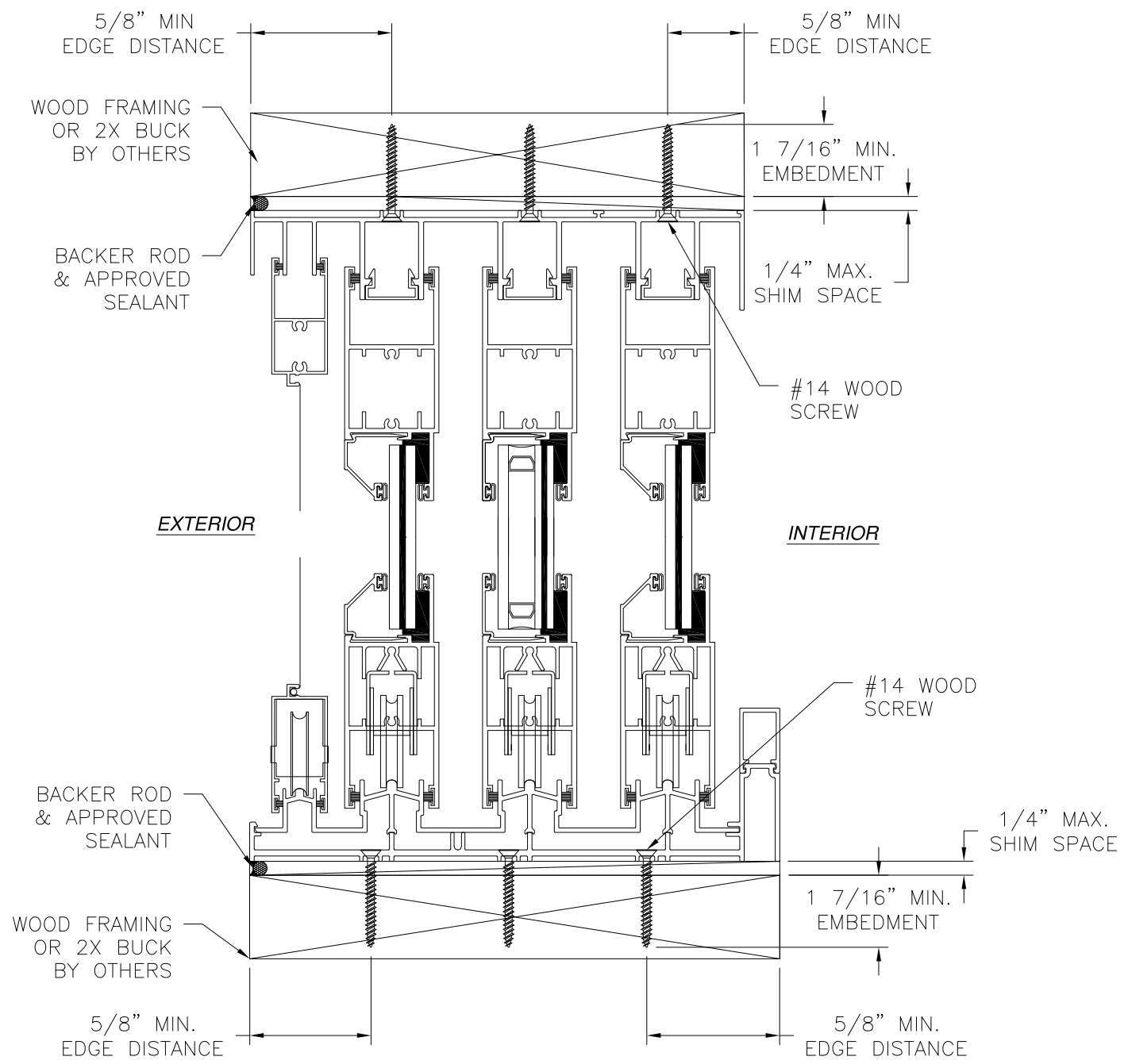

VERTICAL CROSS SECTION
WOOD FRAMING OR 2X BUCK INSTALLATION

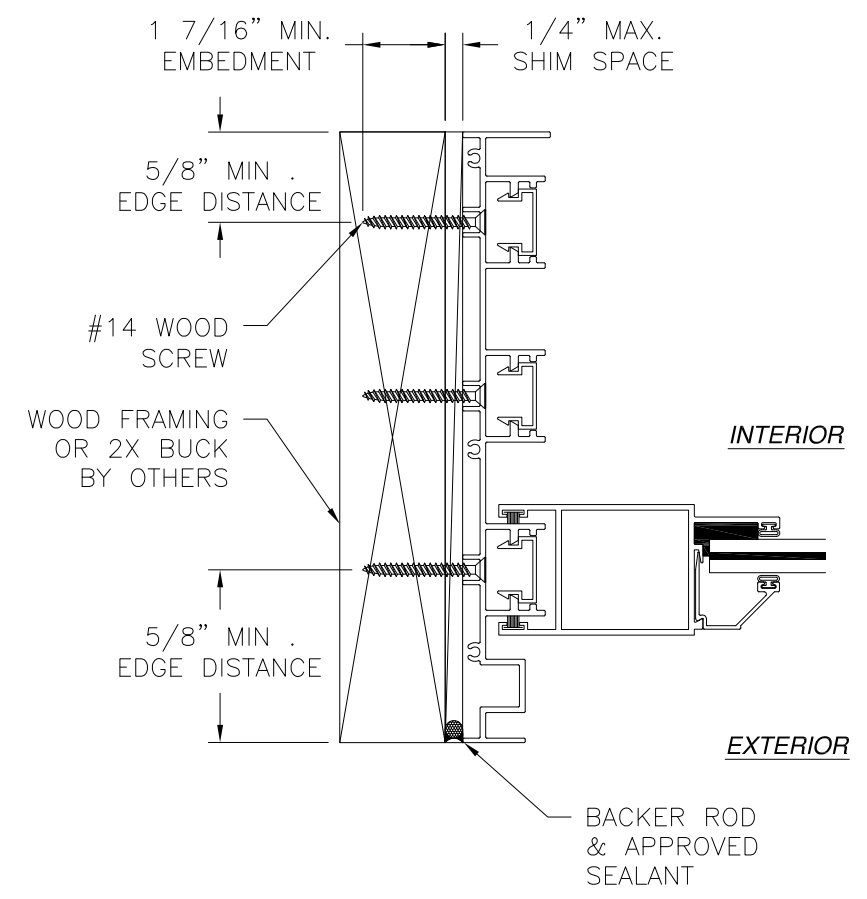

JAMB INSTALLATION DETAIL
WOOD FRAMING OR 2X BUCK INSTALLATION

NOTES:
 1. INTERIOR AND EXTERIOR FINISHES, BY OTHERS, NOT SHOWN FOR CLARITY.
 2. PERIMETER AND JOINT SEALANT BY OTHERS TO BE DESIGNED IN ACCORDANCE WITH ASTM E2112

SIGNED: 01/09/2018

		EASTERN ARCHITECTURAL SYSTEMS A DIVISION OF EASTERN METAL SUPPLY 16341 DOMESTIC AVE FORT MYERS, FL 33912 800-432-2204	
SERIES FD8100 ALUMINUM IMPACT RATED SLIDING GLASS DOOR 3 TRACK INSTALLATION DETAILS			
DRAWN: V.L.	DWG NO. 08-02672	REV A	
SCALE NTS	DATE 03/30/15	SHEET 6 OF 12	
L. ROBERTO LOMAS P.E. 1432 WOODFORD RD LEWISVILLE, NC 27023 434-688-0609 rllomas@rlomaspe.com			

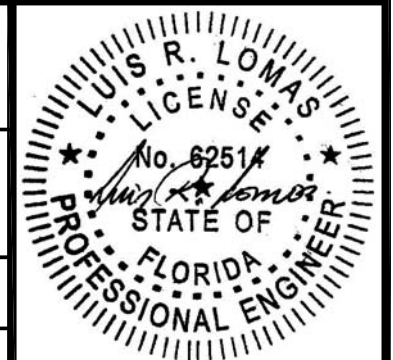

Luis R. Lomas P.E.
FL No.: 62514

REVISIONS			
REV	DESCRIPTION	DATE	APPROVED
A	REVISED PER NEW REQUIREMENTS	01/09/18	R.L.

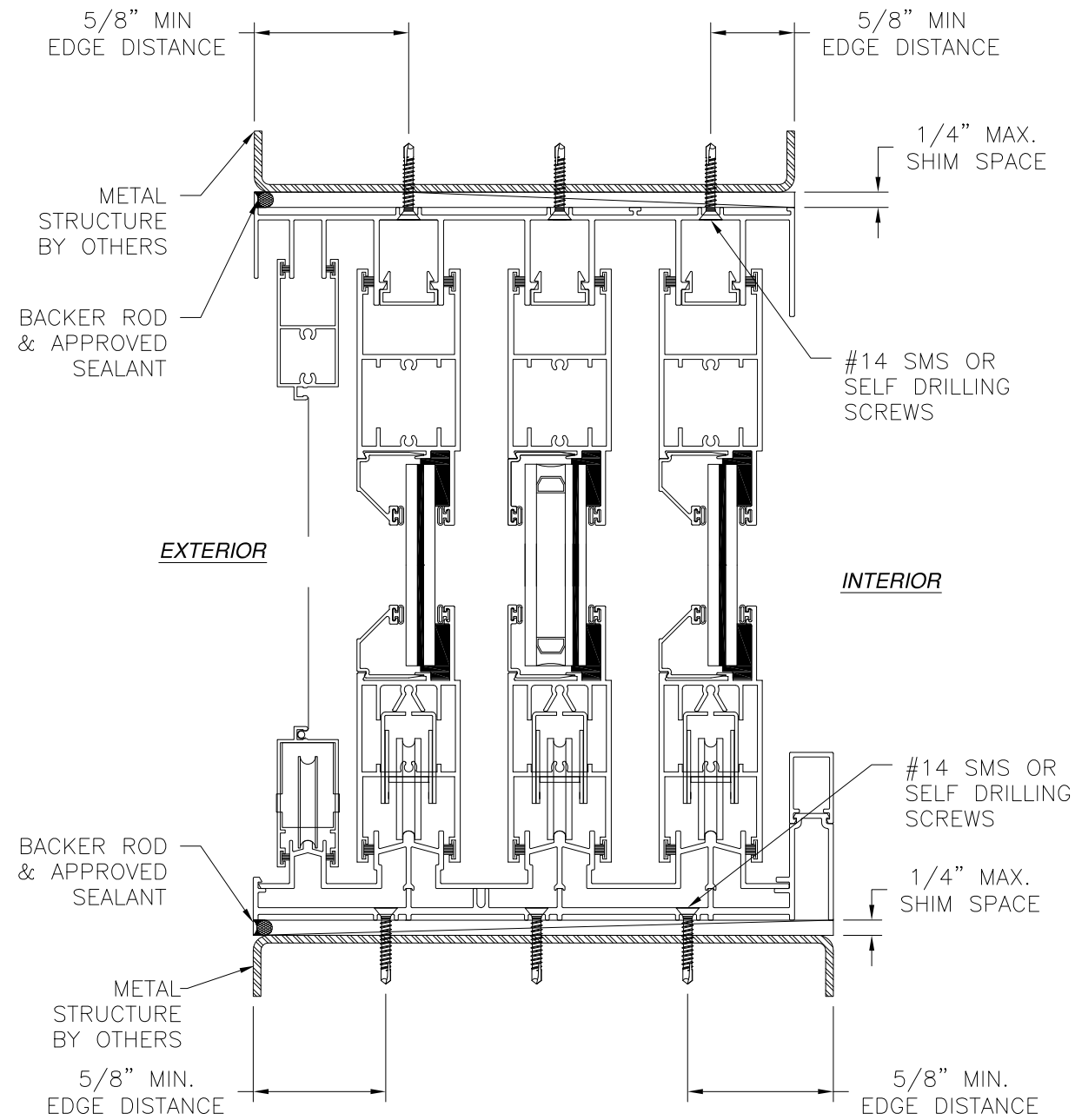

VERTICAL CROSS SECTION
METAL STRUCTURE INSTALLATION

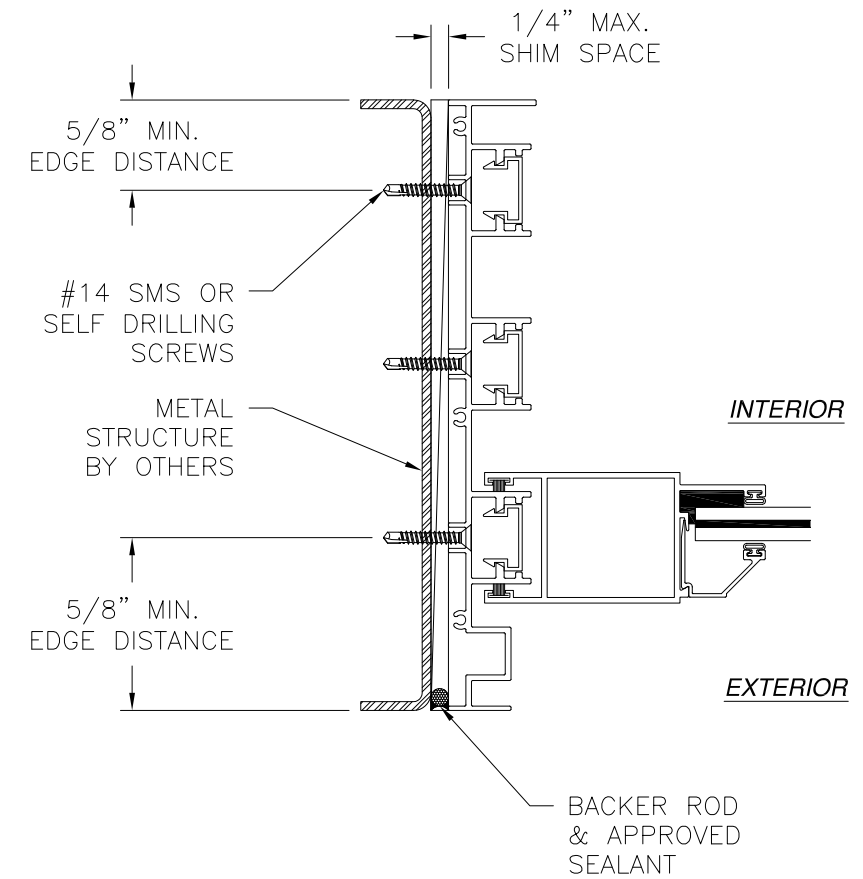

JAMB INSTALLATION DETAIL
METAL STRUCTURE INSTALLATION

NOTES:
 1. INTERIOR AND EXTERIOR FINISHES, BY OTHERS, NOT SHOWN FOR CLARITY.
 2. PERIMETER AND JOINT SEALANT BY OTHERS TO BE DESIGNED IN ACCORDANCE WITH ASTM E2112

		EASTERN ARCHITECTURAL SYSTEMS A DIVISION OF EASTERN METAL SUPPLY 16341 DOMESTIC AVE FORT MYERS, FL 33912 800-432-2204	
SERIES FD8100 ALUMINUM IMPACT RATED SLIDING GLASS DOOR 3 TRACK INSTALLATION DETAILS			
DRAWN: V.L.	DWG NO. 08-02672	REV A	
SCALE NTS	DATE 03/30/15	SHEET 7 OF 12	
L. ROBERTO LOMAS P.E. 1432 WOODFORD RD LEWISVILLE, NC 27023 434-688-0609 rllomas@rlomaspe.com			

SIGNED: 01/09/2018

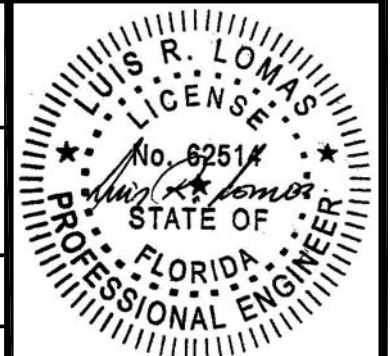

Luis R. Lomas P.E.
 FL No.: 62514

REVISIONS			
REV	DESCRIPTION	DATE	APPROVED
A	REVISED PER NEW REQUIREMENTS	01/09/18	R.L.

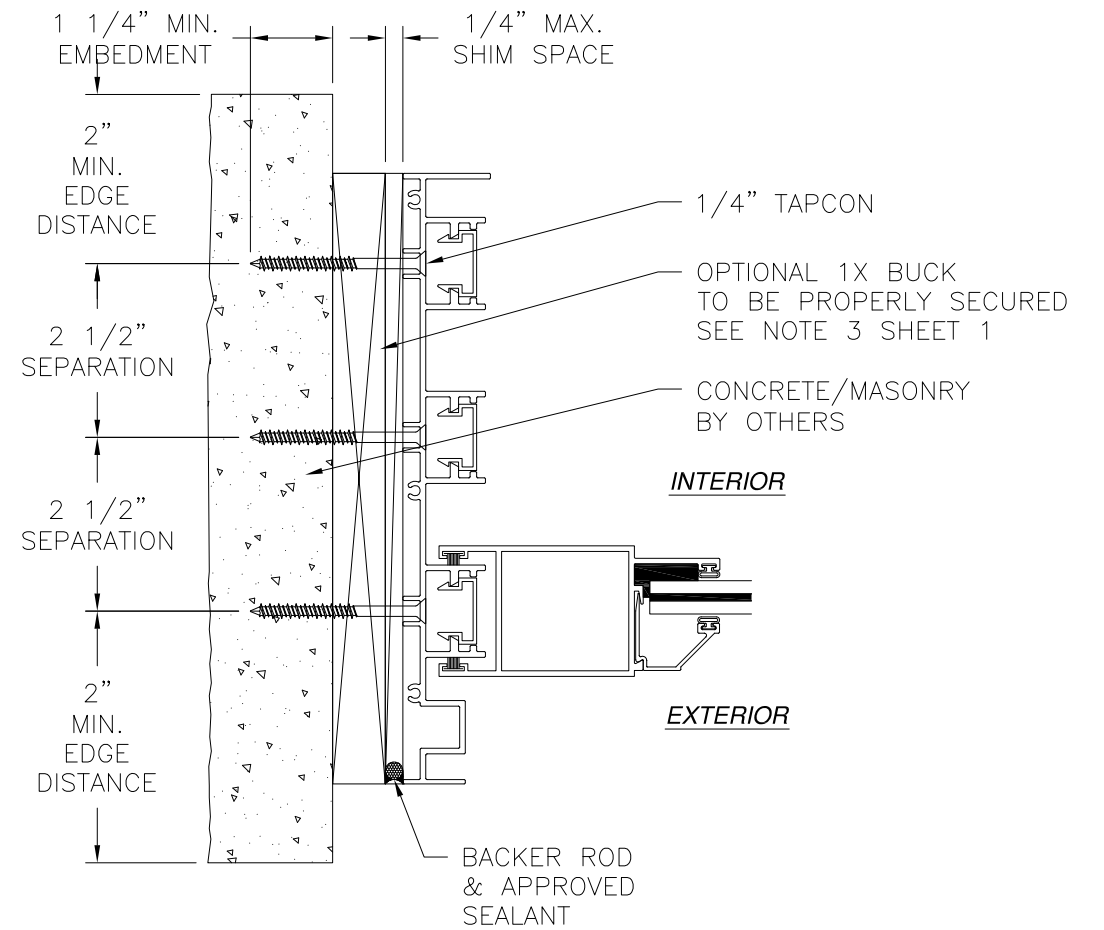
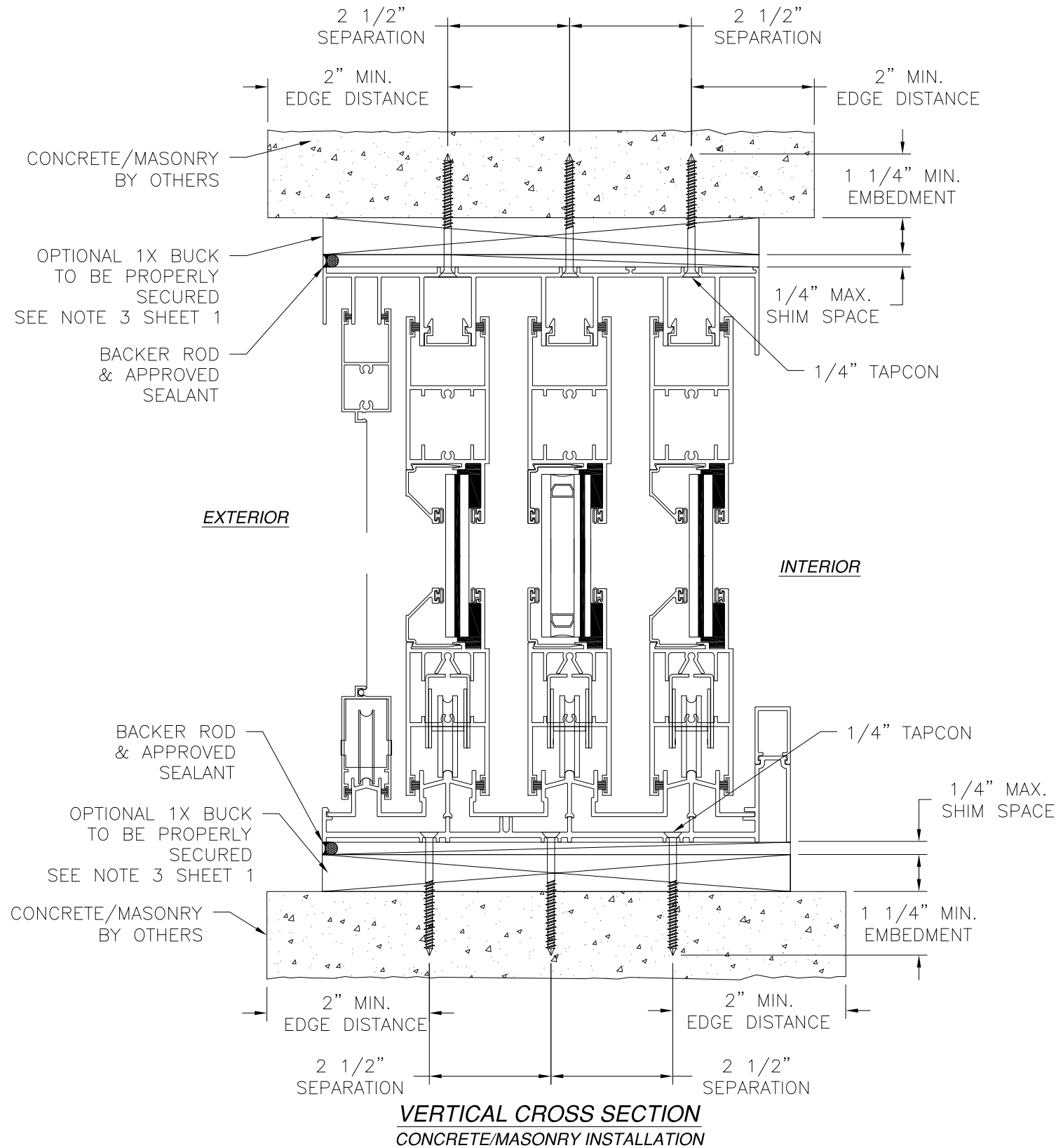

- NOTES:**
1. INTERIOR AND EXTERIOR FINISHES, BY OTHERS, NOT SHOWN FOR CLARITY.
 2. PERIMETER AND JOINT SEALANT BY OTHERS TO BE DESIGNED IN ACCORDANCE WITH ASTM E2112

SIGNED: 01/09/2018

		EASTERN ARCHITECTURAL SYSTEMS A DIVISION OF EASTERN METAL SUPPLY 16341 DOMESTIC AVE FORT MYERS, FL 33912 800-432-2204	
SERIES FD8100 ALUMINUM IMPACT RATED SLIDING GLASS DOOR 3 TRACK INSTALLATION DETAILS			
DRAWN: V.L.	DWG NO. 08-02672	REV A	
SCALE NTS	DATE 03/30/15	SHEET 8 OF 12	
L. ROBERTO LOMAS P.E. 1432 WOODFORD RD LEWISVILLE, NC 27023 434-688-0609 rllomas@rlomaspe.com			

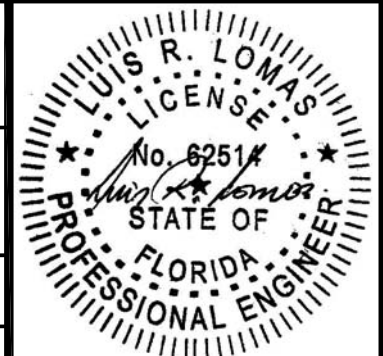

Luis R. Lomas P.E.
FL No.: 62514

REVISIONS			
REV	DESCRIPTION	DATE	APPROVED
A	REVISED PER NEW REQUIREMENTS	01/09/18	R.L.

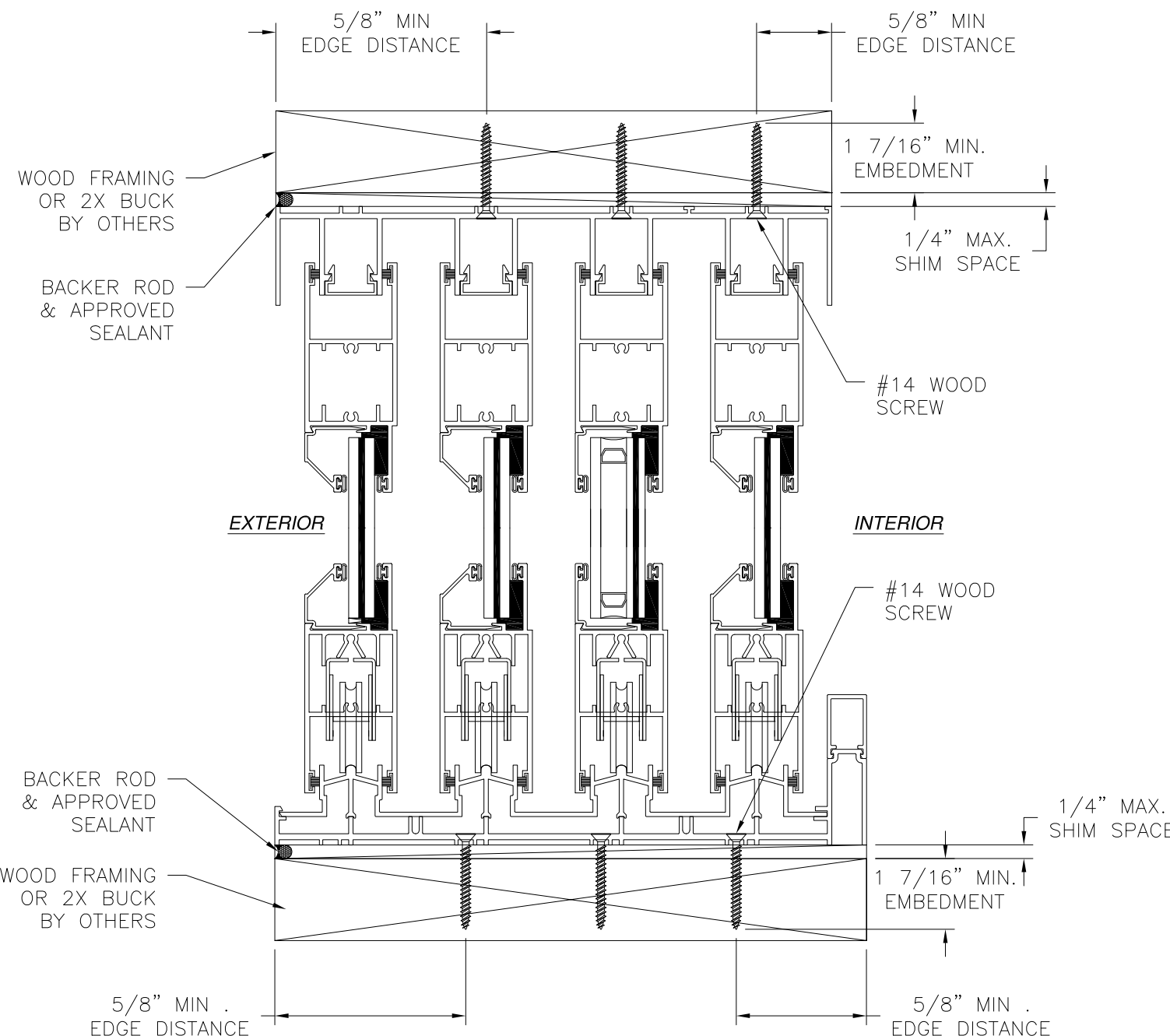

VERTICAL CROSS SECTION
WOOD FRAMING OR 2X BUCK INSTALLATION

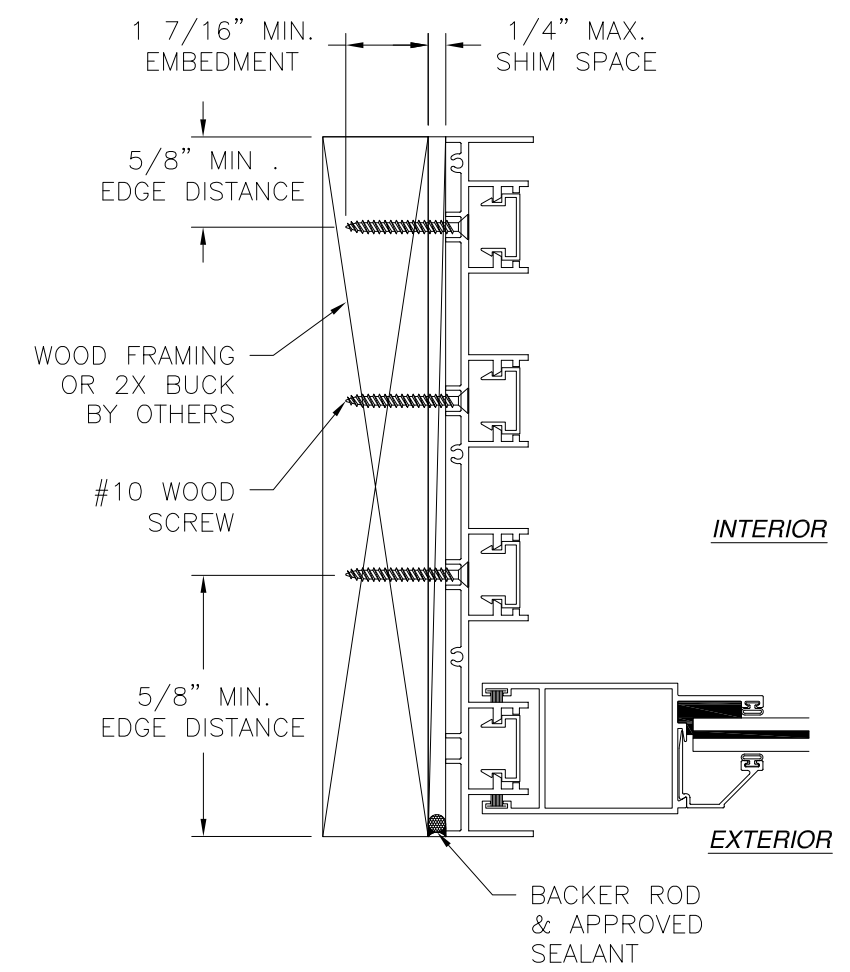

JAMB INSTALLATION DETAIL
WOOD FRAMING OR 2X BUCK INSTALLATION

NOTES:
 1. INTERIOR AND EXTERIOR FINISHES, BY OTHERS, NOT SHOWN FOR CLARITY.
 2. PERIMETER AND JOINT SEALANT BY OTHERS TO BE DESIGNED IN ACCORDANCE WITH ASTM E2112

SIGNED: 01/09/2018

		EASTERN ARCHITECTURAL SYSTEMS A DIVISION OF EASTERN METAL SUPPLY 16341 DOMESTIC AVE FORT MYERS, FL 33912 800-432-2204	
SERIES FD8100 ALUMINUM IMPACT RATED SLIDING GLASS DOOR 4 TRACK INSTALLATION DETAILS			
DRAWN: V.L.	DWG NO. 08-02672	REV A	
SCALE NTS	DATE 03/30/15	SHEET 9 OF 12	
L. ROBERTO LOMAS P.E. 1432 WOODFORD RD LEWISVILLE, NC 27023 434-688-0609 rllomas@rlomaspe.com			

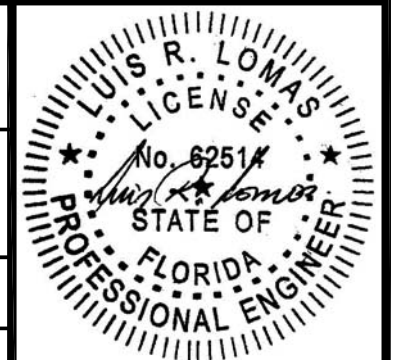

Luis R. Lomas P.E.
FL No.: 62514

REVISIONS			
REV	DESCRIPTION	DATE	APPROVED
A	REVISED PER NEW REQUIREMENTS	01/09/18	R.L.

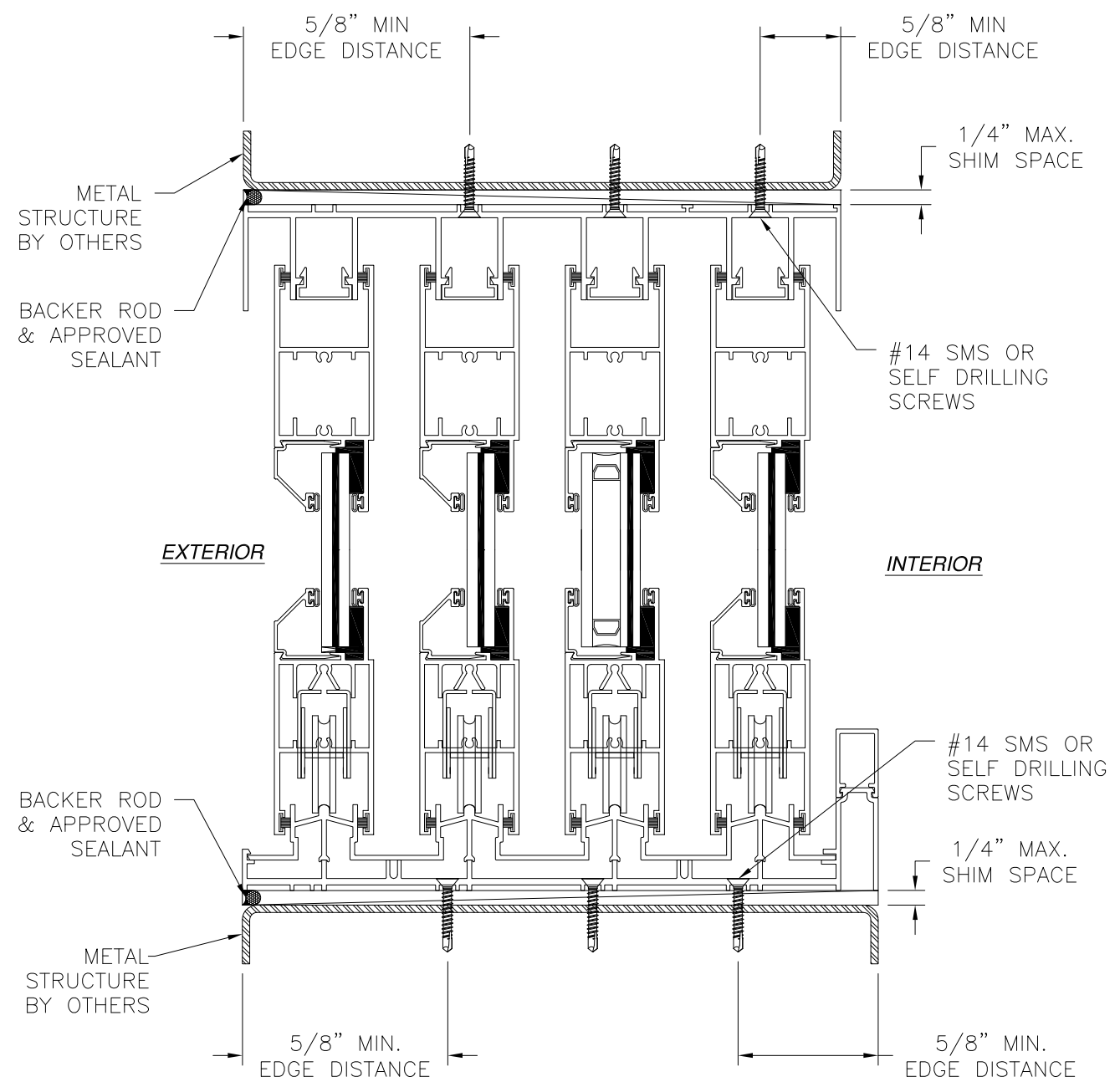

VERTICAL CROSS SECTION
METAL STRUCTURE INSTALLATION

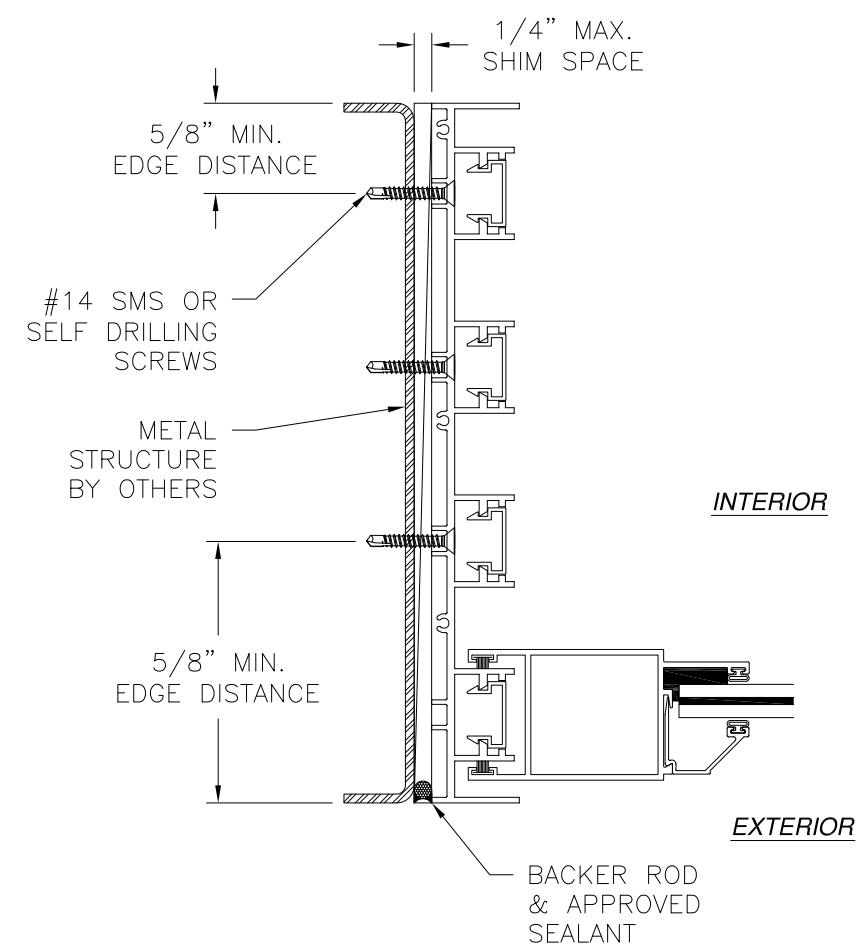

JAMB INSTALLATION DETAIL
METAL STRUCTURE INSTALLATION

NOTES:
 1. INTERIOR AND EXTERIOR FINISHES, BY OTHERS, NOT SHOWN FOR CLARITY.
 2. PERIMETER AND JOINT SEALANT BY OTHERS TO BE DESIGNED IN ACCORDANCE WITH ASTM E2112

SIGNED: 01/09/2018

		EASTERN ARCHITECTURAL SYSTEMS A DIVISION OF EASTERN METAL SUPPLY 16341 DOMESTIC AVE FORT MYERS, FL 33912 800-432-2204	
SERIES FD8100 ALUMINUM IMPACT RATED SLIDING GLASS DOOR 4 TRACK INSTALLATION DETAILS			
DRAWN: V.L.	DWG NO. 08-02672	REV A	
SCALE NTS	DATE 03/30/15	SHEET 10 OF 12	
L. ROBERTO LOMAS P.E. 1432 WOODFORD RD LEWISVILLE, NC 27023 434-688-0609 rllomas@lrlomaspe.com			

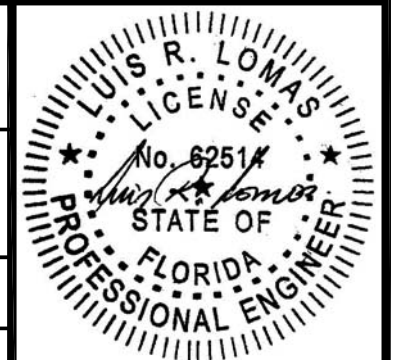

Luis R. Lomas P.E.
FL No.: 62514

REVISIONS			
REV	DESCRIPTION	DATE	APPROVED
A	REVISED PER NEW REQUIREMENTS	01/09/18	R.L.

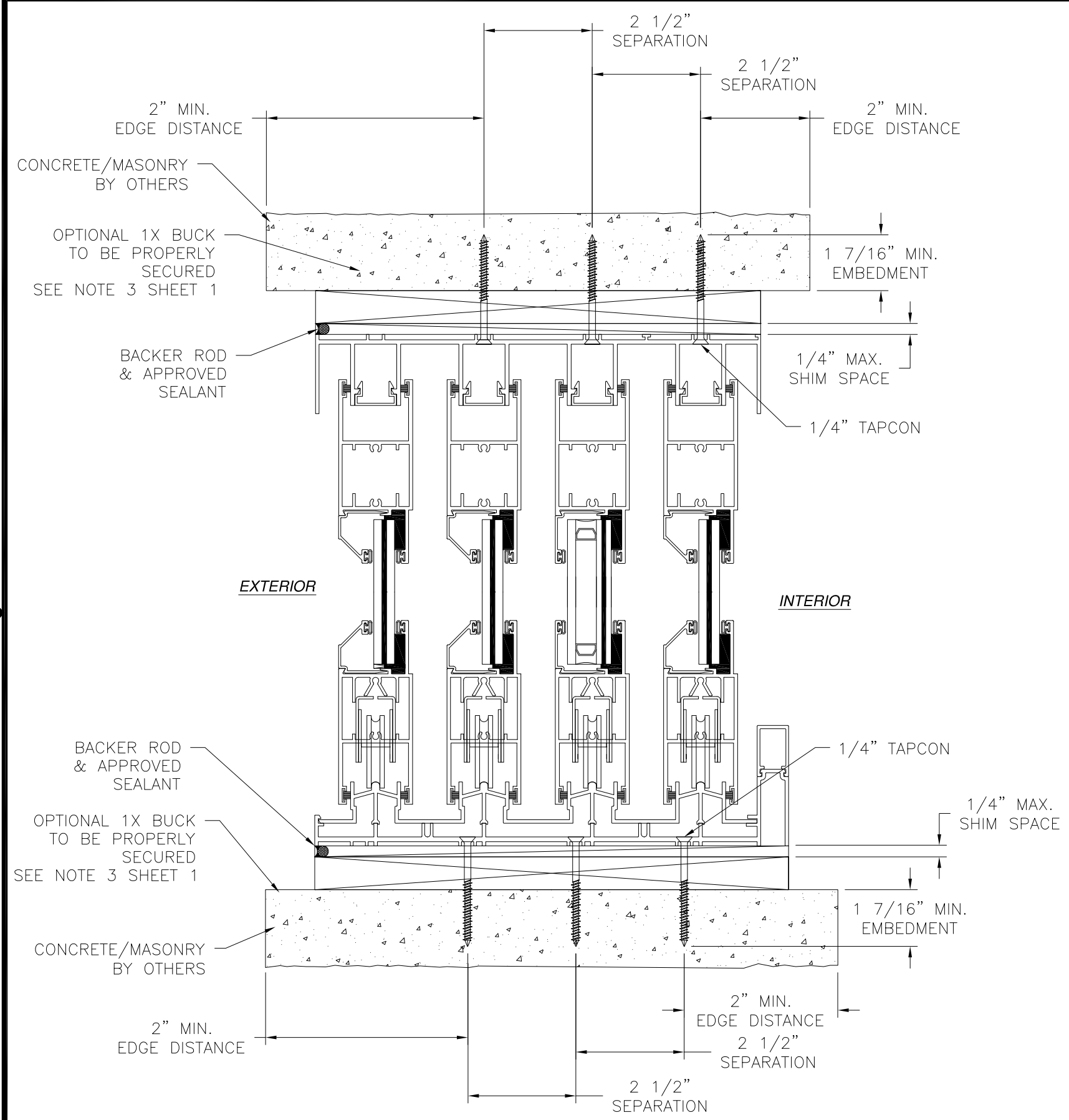

VERTICAL CROSS SECTION
CONCRETE/MASONRY INSTALLATION

NOTES:
 1. INTERIOR AND EXTERIOR FINISHES, BY OTHERS, NOT SHOWN FOR CLARITY.
 2. PERIMETER AND JOINT SEALANT BY OTHERS TO BE DESIGNED IN ACCORDANCE WITH ASTM E2112

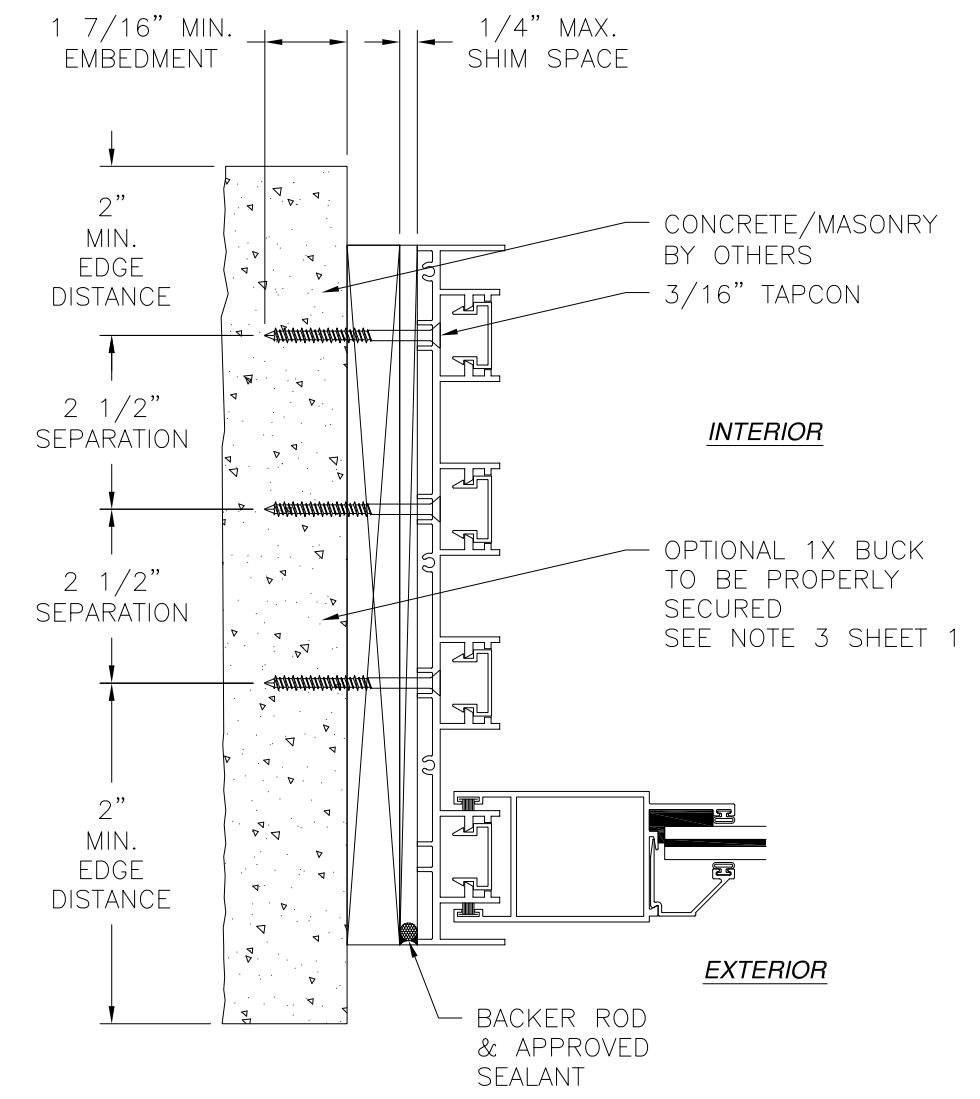

JAMB INSTALLATION DETAIL
CONCRETE/MASONRY INSTALLATION



Eastern
ARCHITECTURAL SYSTEMS
ALUMINUM AND VINYL
IMPACT WINDOWS AND DOORS

EASTERN ARCHITECTURAL SYSTEMS
 A DIVISION OF
 EASTERN METAL SUPPLY
 16341 DOMESTIC AVE
 FORT MYERS, FL 33912
 800-432-2204

**SERIES FD8100 ALUMINUM IMPACT RATED
SLIDING GLASS DOOR
4 TRACK INSTALLATION DETAILS**

DRAWN: V.L.	DWG NO. 08-02672	REV A
SCALE NTS	DATE 03/30/15	SHEET 11 OF 12

L. ROBERTO LOMAS P.E.
 1432 WOODFORD RD LEWISVILLE, NC 27023
 434-688-0609 rllomas@rlomaspe.com

SIGNED: 01/09/2018

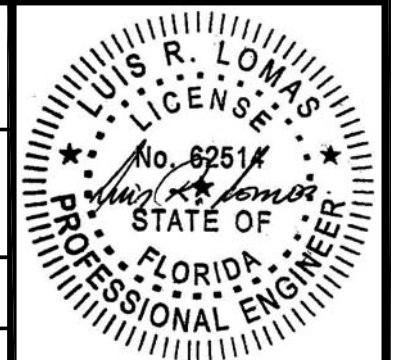

Luis R. Lomas P.E.
FL No.: 62514

REVISIONS			
REV	DESCRIPTION	DATE	APPROVED
A	REVISED PER NEW REQUIREMENTS	01/09/18	R.L.

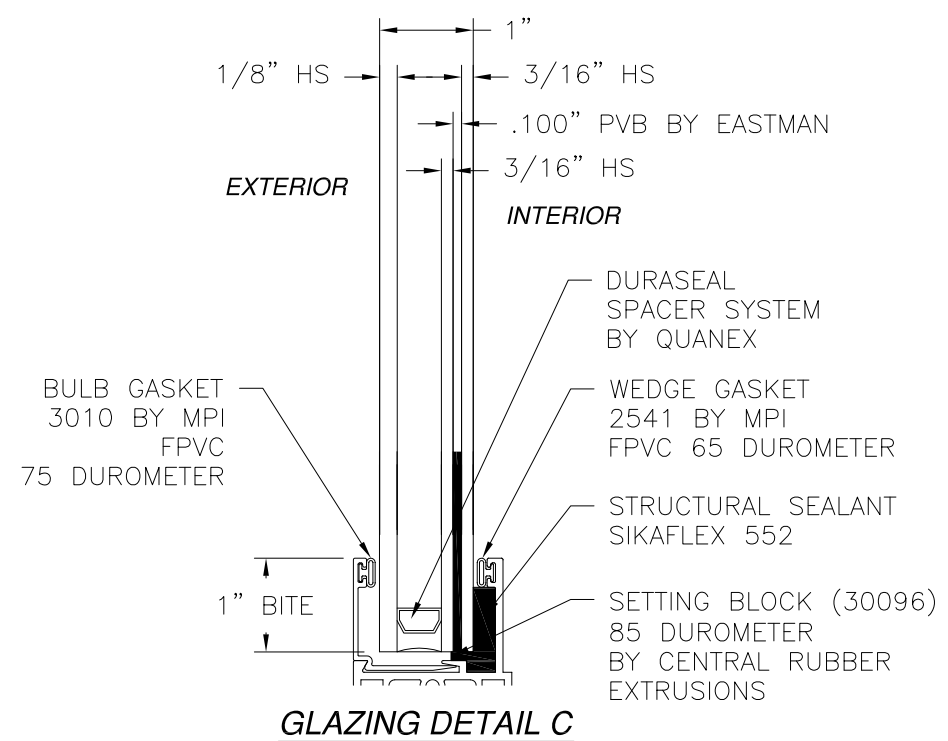
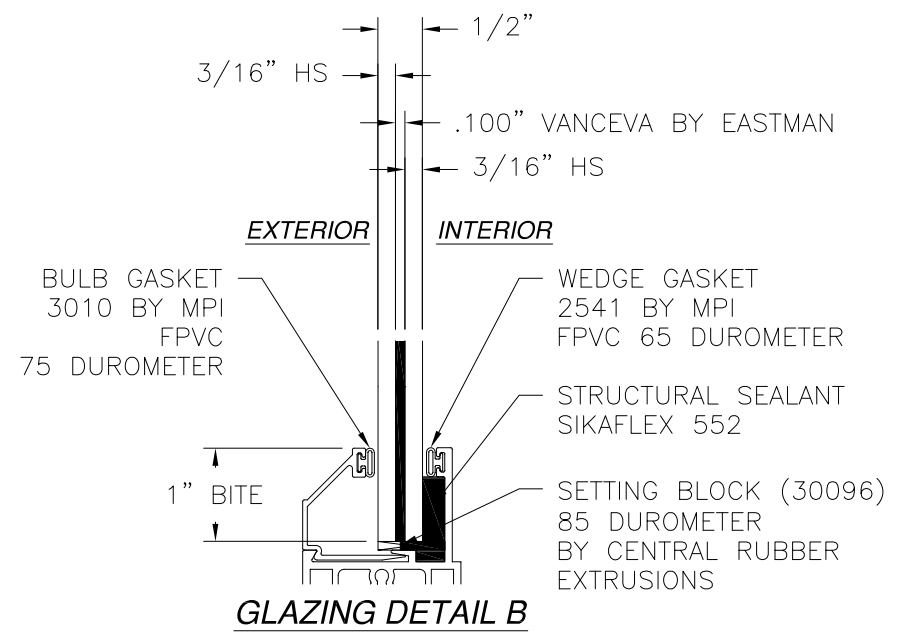
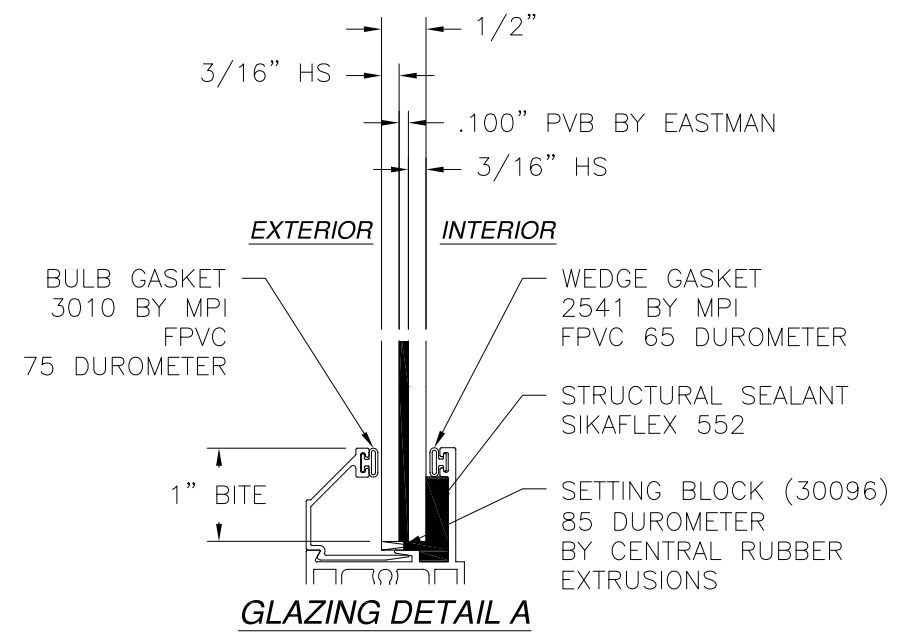

SIGNED: 01/09/2018

Eastern
ARCHITECTURAL SYSTEMS
ALUMINUM AND VINYL
IMPACT WINDOWS AND DOORS

EASTERN ARCHITECTURAL SYSTEMS
A DIVISION OF
EASTERN METAL SUPPLY
16341 DOMESTIC AVE
FORT MYERS, FL 33912
800-432-2204

SERIES FD8100 ALUMINUM IMPACT RATED
SLIDING GLASS DOOR
GLAZING DETAILS

DRAWN: V.L.	DWG NO. 08-02672	REV A
SCALE NTS	DATE 03/30/15	SHEET 12 OF 12

L. ROBERTO LOMAS P.E.
1432 WOODFORD RD LEWISVILLE, NC 27023
434-688-0609 rllomas@rlomaspe.com



Luis R. Lomas P.E.
FL No.: 62514