

SWING DOOR & SIDELITE - LARGE MISSILE IMPACT

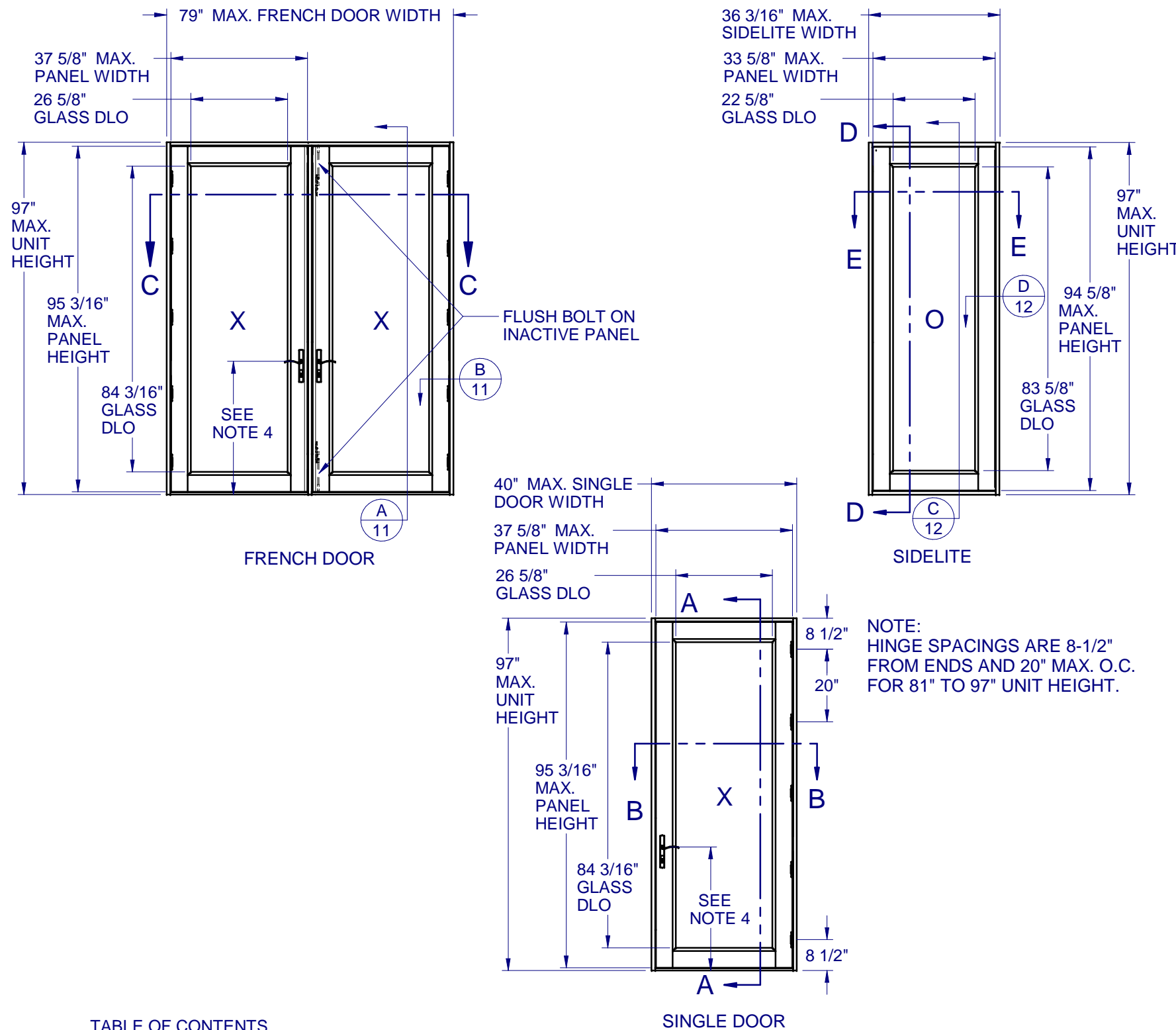

TABLE OF CONTENTS

GENERAL NOTES & ELEVATIONS.....1-3
 GLAZING DETAILS.....4
 SECTION VIEWS.....5-7
 BOM.....8
 EXTRUSIONS.....9
 ANCHOR SCHEDULE & NOTES.....10
 INSTALLATION DETAILS.....11-12

TYPE	MAX. PANEL SIZE	DESIGN PRESSURE RATING	IMPACT RATING
SINGLE	37-5/8" x 95-3/16"	+/- 70 PSF	LARGE MISSILE IMPACT
FRENCH			
SIDELITE	33-5/8" x 94-5/8"		

GENERAL NOTES:

- THE PRODUCT SHOWN HEREIN IS DESIGNED AND MANUFACTURED TO COMPLY WITH THE FLORIDA BUILDING CODE (FBC), CURRENT EDITION INCLUDING THE HIGH VELOCITY HURRICANE ZONE (HVHZ) AND IS RATED FOR WIND ZONE 4 MISSILE LEVEL D IMPACT USE AS DEFINED IN ASTM E 1996 PER THE FBC.
- GLAZING OPTIONS: (SEE SHEET 4)
- CONFIGURATIONS: SINGLE OUTSWING, SINGLE OUTSWING w/SIDELITE(S), FRENCH DOOR(S), FRENCH DOOR(S) w/SIDELITE(S), SIDELITE NOT ATTACHED.
- LOCK OPTIONS:
 UP TO 6'8":
 A. DOUBLE BORE w/TWO (2) INTERIOR FLUSH BOLTS. HANDLE SET @ 36"
 B. MORTISE LOCK w/ TWO (2) INTERIOR FLUSH BOLTS. HANDLE SET @ 34"
 C. MULTIPOINT (4 PT.) HANDLE SET @ 34"
 ABOVE 6'8":
 A. MULTIPOINT (5 PT.) HANDLE SET @ 34"
- DESIGN PRESSURE RATING:
 -NEGATIVE DESIGN LOADS BASED ON, TESTED PRESSURE AND GLASS TABLES ASTM E-1300-04e01/09.
 -POSITIVE DESIGN LOADS BASED ON, TESTED PRESSURE, WATER INFILTRATION TEST PRESSURE AND GLASS TABLES ASTM E-1300-04e01/09.
- ANCHORAGE: THE 33 1/3% STRESS INCREASE HAS NOT BEEN USED IN THE DESIGN OF THIS PRODUCT. SEE SHEETS 11-12 FOR ANCHOR DETAILS. WINDLOAD DURATION FACTOR Cd=1.6 WAS USED FOR WOOD ANCHOR CALCULATIONS.
- PRODUCTS APPROVED FOR IMPACT RESISTANCE. SHUTTERS ARE NOT REQUIRED.
- ALL FRAMES ARE PROCESSED AND SCREWED TOGETHER. PANELS ARE PROCESSED AND ASSEMBLED VIA TIE ROD.
- SERIES / MODEL DESIGNATION SD-8700, FD-8750, SLT-8710.
- THE DESIGNATION X AND O STAND FOR THE FOLLOWING:
 X = OPERABLE SASH, O = FIXED SASH
- SECTION CALLOUTS APPLY TO ALL CONFIGURATIONS IN A SIMILAR LOCATION.
- INTERIOR FLUSH BOLTS ON ACTIVE PANEL TO BE ENGAGED PRIOR TO SEVERE WEATHER.
- QUALIFIED ALTERNATIVE LOCKSET/DEADBOLT HARDWARE IS GRADE 2 BY PAMEX AND DELANY.
- MAX. PANEL WIDTHS APPLY TO ALL CONFIGURATIONS, MULLED OR NON-MULLED UNITS.



8700/10/50 PVC SWING DOOR IMPACT

PROPRIETARY AND CONFIDENTIAL
 THE INFORMATION CONTAINED IN THIS DRAWING IS THE SOLE PROPERTY OF CUSTOM WINDOW SYSTEMS, INC. ANY REPRODUCTION IN PART OR AS A WHOLE WITHOUT THE WRITTEN PERMISSION OF CUSTOM WINDOW SYSTEMS, INC IS PROHIBITED.

FLORIDA APPROVAL NO.: 14850



9/25/2023

LUCAS A. TURNER, P.E.
 FL PE # 58201
 Turner Engineering & Consulting, Inc.
 2428 Old Natchez Trc Trl
 Camden, TN 38320
 PH. 941-380-1574

SHEET DESCRIPTION:
GENERAL NOTES AND ELEVATIONS

DRAWN BY: MCS	DATE: 9/20/2023
DWG #: CWS-641	REV.: E
SCALE: 1:35	SHEET 1 OF 12



1900 SW 44TH AVE.
 Ocala, Florida 34474
 WWW.CWS.CC

**8700/10/50 PVC
 SWING DOOR
 IMPACT**

PROPRIETARY AND CONFIDENTIAL
 THE INFORMATION CONTAINED IN
 THIS DRAWING IS THE SOLE
 PROPERTY OF CUSTOM WINDOW
 SYSTEMS, INC. ANY
 REPRODUCTION IN PART OR AS A
 WHOLE WITHOUT THE WRITTEN
 PERMISSION OF CUSTOM WINDOW
 SYSTEMS, INC IS PROHIBITED.

FLORIDA APPROVAL NO.:

14850



9/25/2023

LUCAS A. TURNER, P.E.
 FL PE # 58201
 Turner Engineering &
 Consulting, Inc.
 2428 Old Natchez Trc Trl
 Camden, TN 38320
 PH. 941-380-1574

SHEET DESCRIPTION:

**GENERAL NOTES AND
 ELEVATIONS**

DRAWN BY:	DATE:
MCS	9/20/2023
DWG #:	REV.:
CWS-641	E
SCALE:	SHEET
1:35	2 OF 12

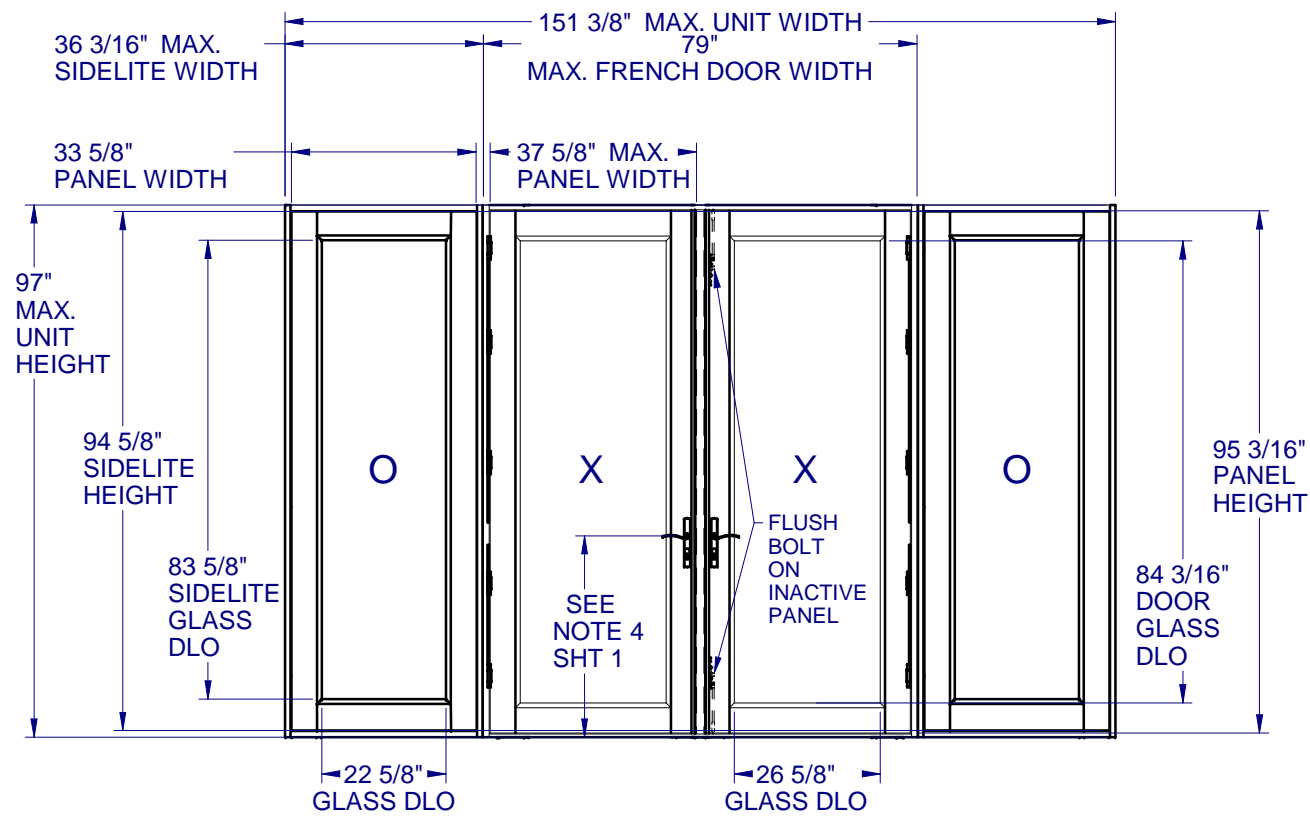

FRENCH DOOR w/SIDELITES

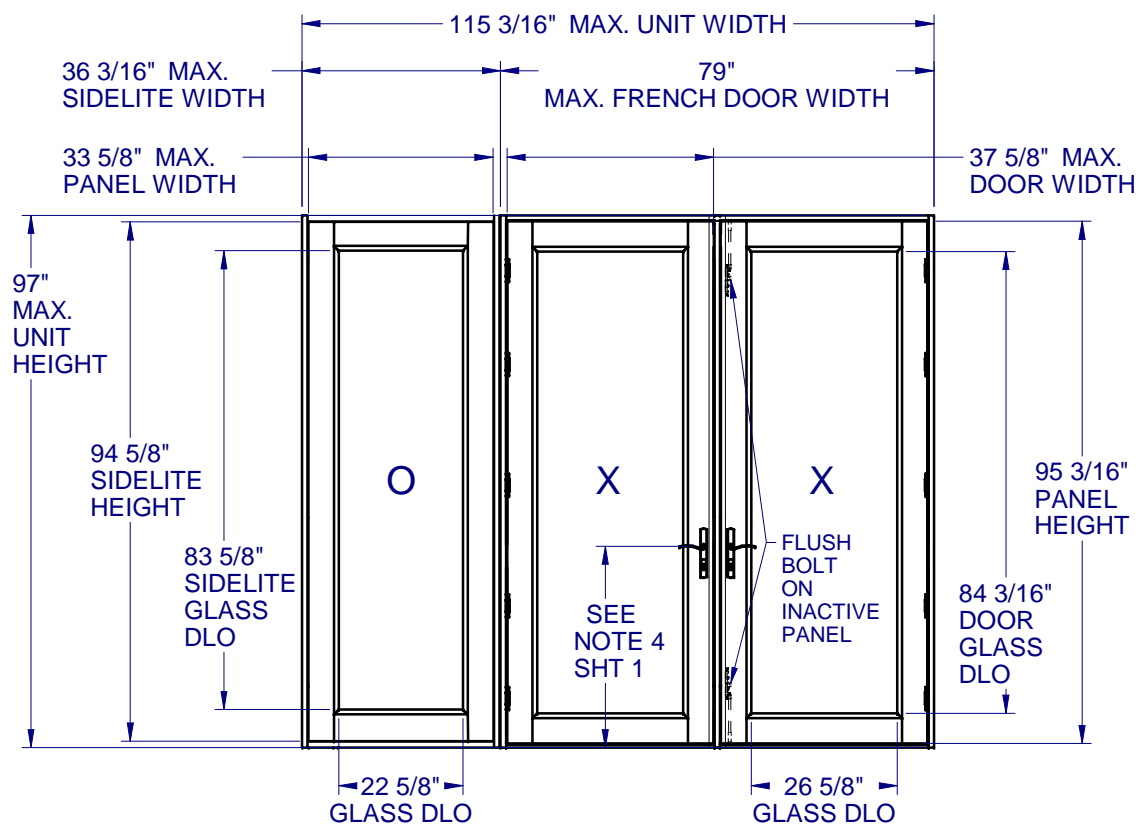

FRENCH DOOR w/SIDLITE

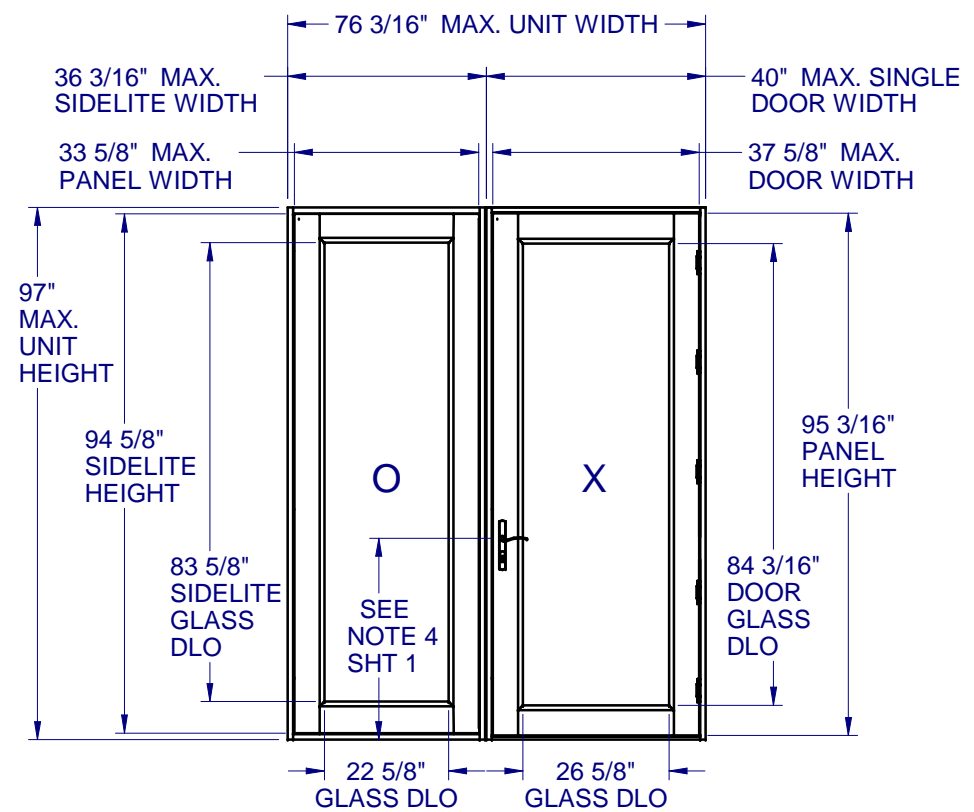

SINGLE DOOR w/SIDLITE

8700/10/50 PVC SWING DOOR IMPACT

PROPRIETARY AND CONFIDENTIAL
 THE INFORMATION CONTAINED IN THIS DRAWING IS THE SOLE PROPERTY OF CUSTOM WINDOW SYSTEMS, INC. ANY REPRODUCTION IN PART OR AS A WHOLE WITHOUT THE WRITTEN PERMISSION OF CUSTOM WINDOW SYSTEMS, INC IS PROHIBITED.

FLORIDA APPROVAL NO.:
 14850

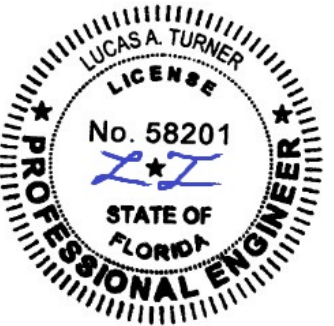

9/25/2023

LUCAS A. TURNER, P.E.
 FL PE # 58201
 Turner Engineering & Consulting, Inc.
 2428 Old Natchez Trc Trl
 Camden, TN 38320
 PH. 941-380-1574

SHEET DESCRIPTION:
GENERAL NOTES AND ELEVATIONS

DRAWN BY: MCS	DATE: 9/20/2023
DWG #: CWS-641	REV.: E
SCALE: 1:35	SHEET 3 OF 12

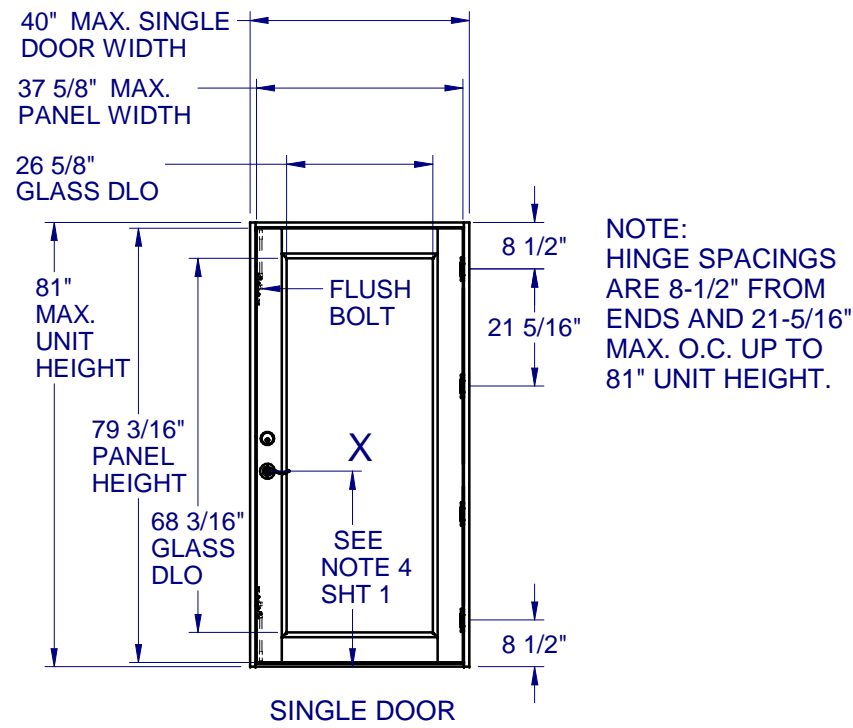

NOTE:
 HINGE SPACINGS ARE 8-1/2" FROM ENDS AND 21-5/16" MAX. O.C. UP TO 81" UNIT HEIGHT.

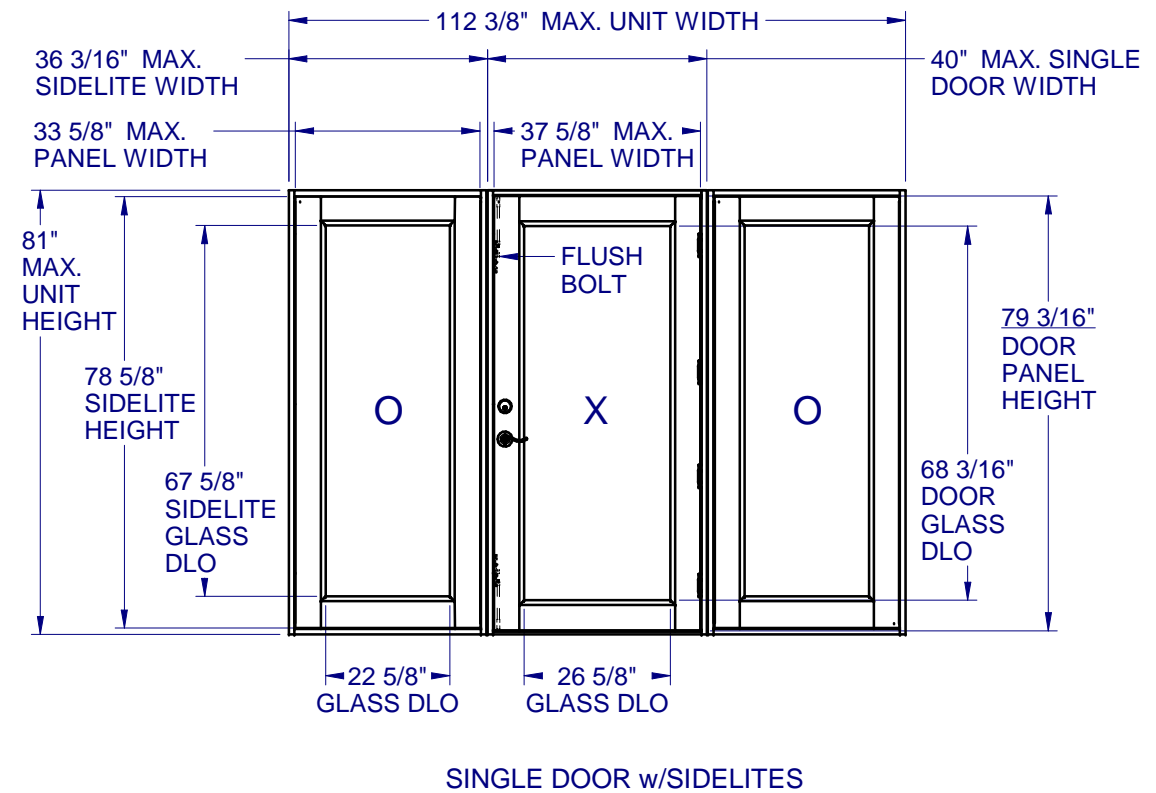
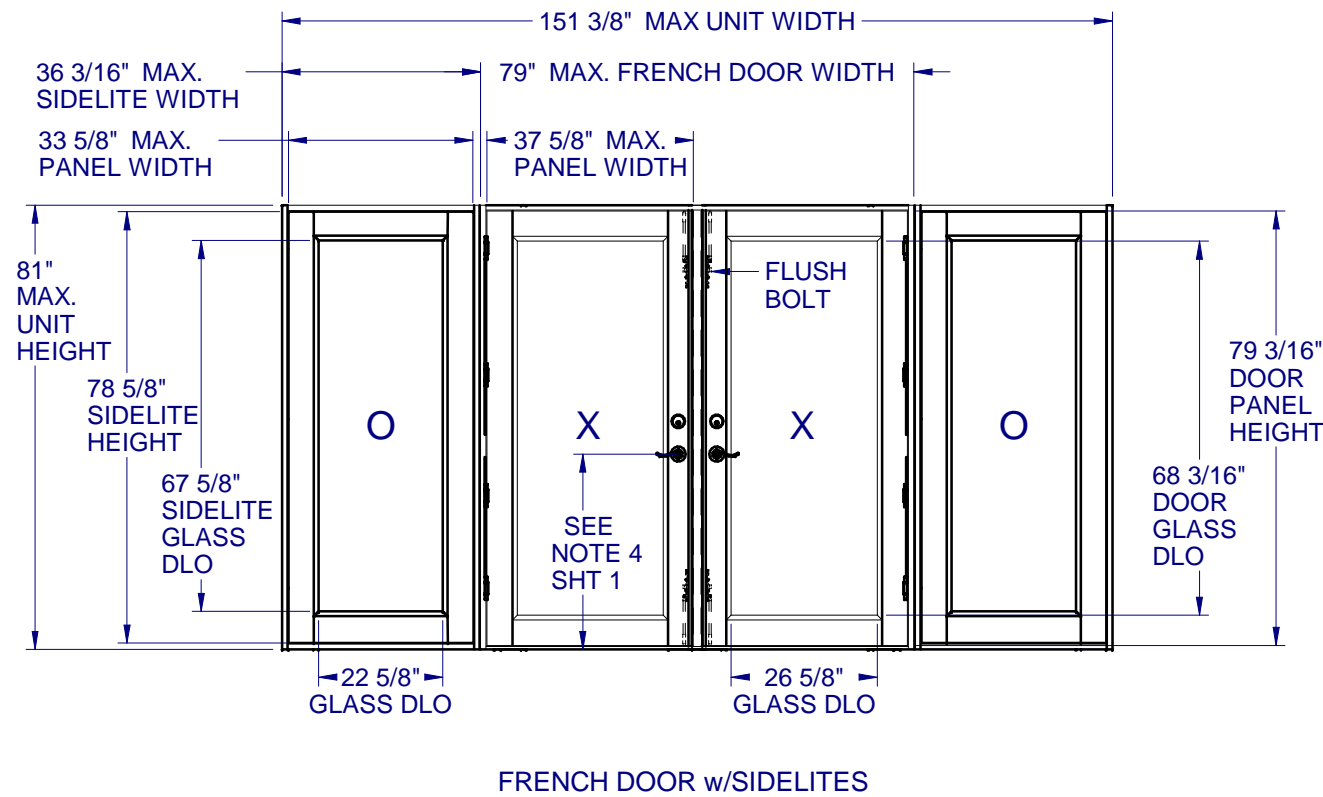
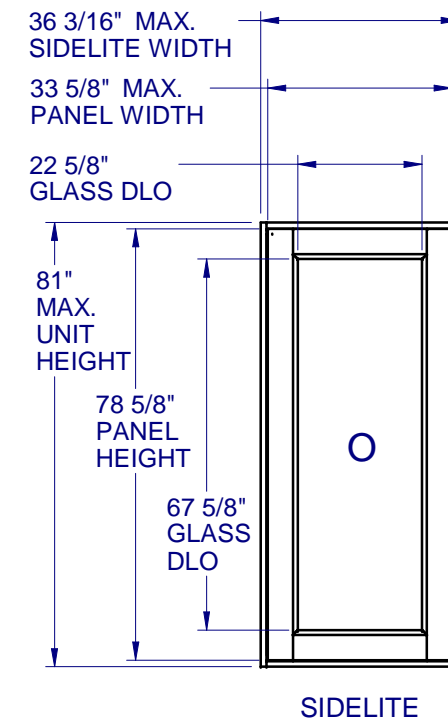
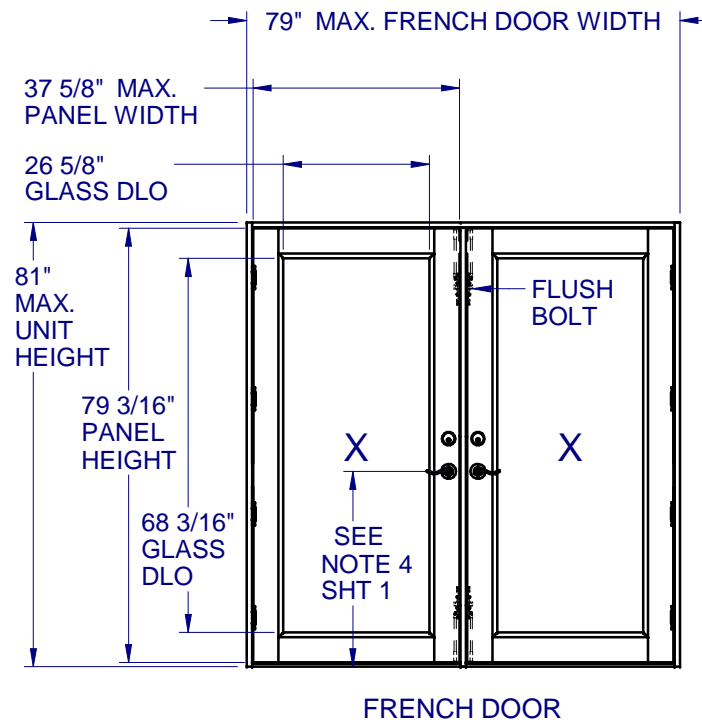



1900 SW 44TH AVE.
OCALA, FLORIDA 34474
WWW.CWS.CC

8700/10/50 PVC SWING DOOR IMPACT

PROPRIETARY AND CONFIDENTIAL
THE INFORMATION CONTAINED IN THIS DRAWING IS THE SOLE PROPERTY OF CUSTOM WINDOW SYSTEMS, INC. ANY REPRODUCTION IN PART OR AS A WHOLE WITHOUT THE WRITTEN PERMISSION OF CUSTOM WINDOW SYSTEMS, INC IS PROHIBITED.

FLORIDA APPROVAL NO.:
14850

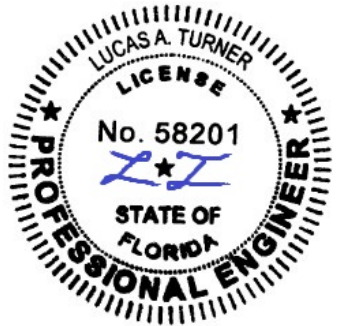

9/25/2023

LUCAS A. TURNER, P.E.
FL PE # 58201
Turner Engineering & Consulting, Inc.
2428 Old Natchez Trc Trl
Camden, TN 38320
PH. 941-380-1574

SHEET DESCRIPTION:

GLAZING DETAILS

DRAWN BY: MCS	DATE: 9/20/2023
DWG #: CWS-641	REV.: E
SCALE: 1:1	SHEET 4 OF 12

MAX. UNIT HEIGHT	GLASS TYPES		
	SIDELITE	SINGLE	FRENCH
81"	A	A	A
97"	B	B	B

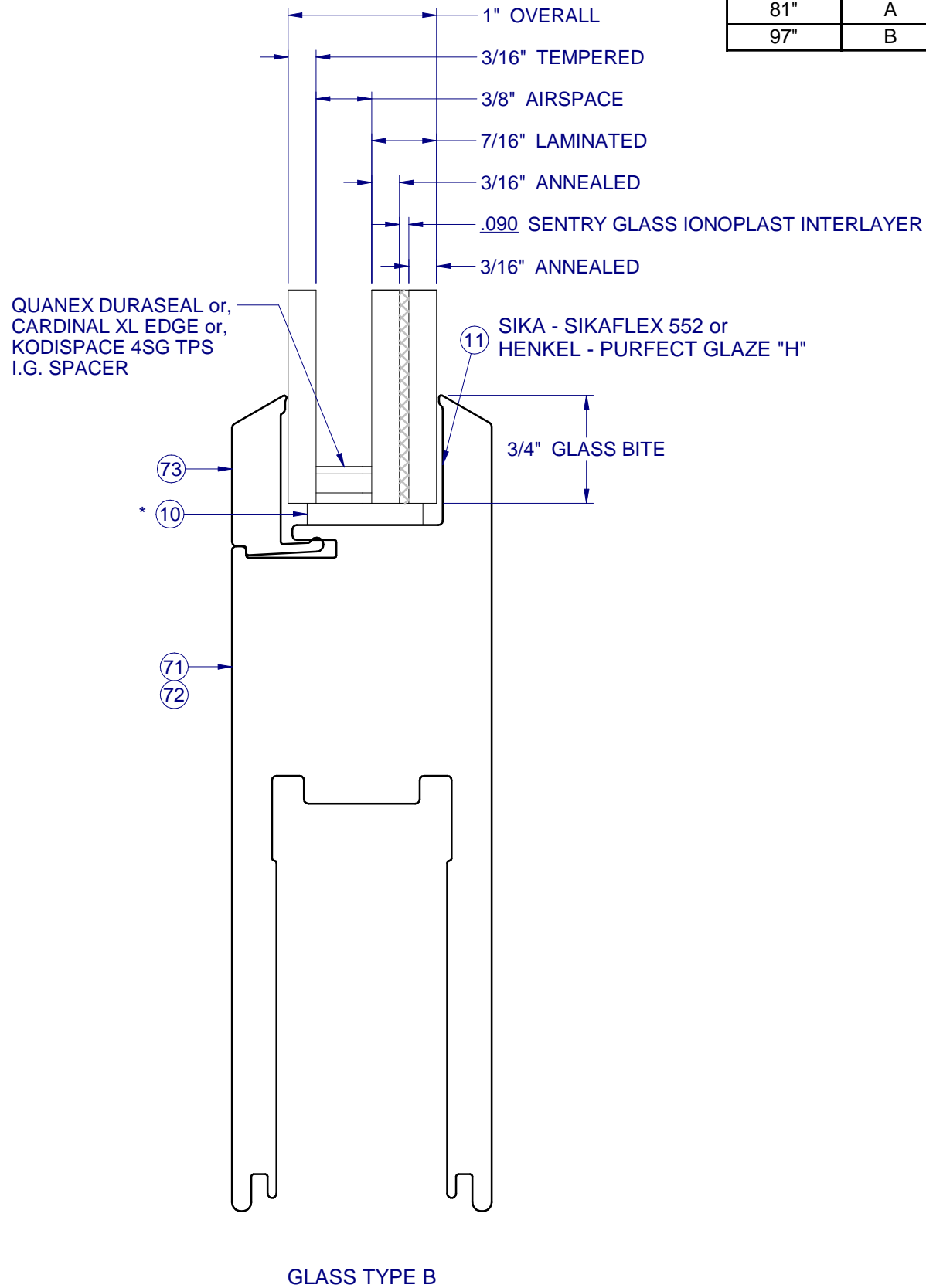
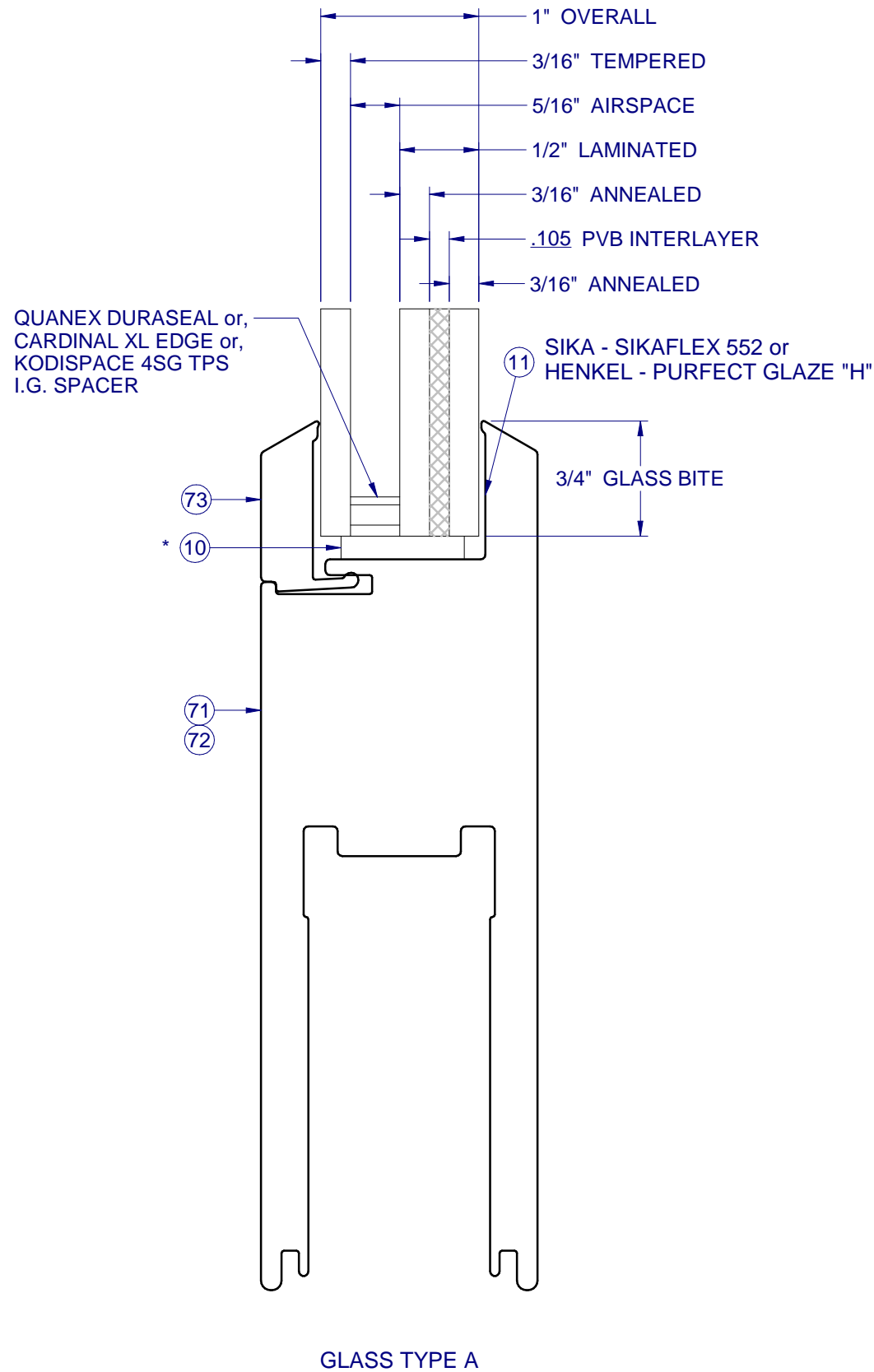

* SETTING BLOCKS PER FBC 2411.3.3.1



1900 SW 44TH AVE.
OCALA, FLORIDA 34474
WWW.CWS.CC

8700/10/50 PVC SWING DOOR IMPACT

PROPRIETARY AND CONFIDENTIAL
THE INFORMATION CONTAINED IN
THIS DRAWING IS THE SOLE
PROPERTY OF CUSTOM WINDOW
SYSTEMS, INC. ANY
REPRODUCTION IN PART OR AS A
WHOLE WITHOUT THE WRITTEN
PERMISSION OF CUSTOM WINDOW
SYSTEMS, INC IS PROHIBITED.

FLORIDA APPROVAL NO.:

14850



9/25/2023

LUCAS A. TURNER, P.E.
FL PE # 58201
Turner Engineering &
Consulting, Inc.
2428 Old Natchez Trc Trl
Camden, TN 38320
PH. 941-380-1574

SHEET DESCRIPTION:

SECTION VIEWS
SINGLE DOOR

DRAWN BY:

MCS

DATE:

9/20/2023

DWG #:

CWS-641

REV.:

E

SCALE:

1:2

SHEET

5 OF 12

INTERIOR

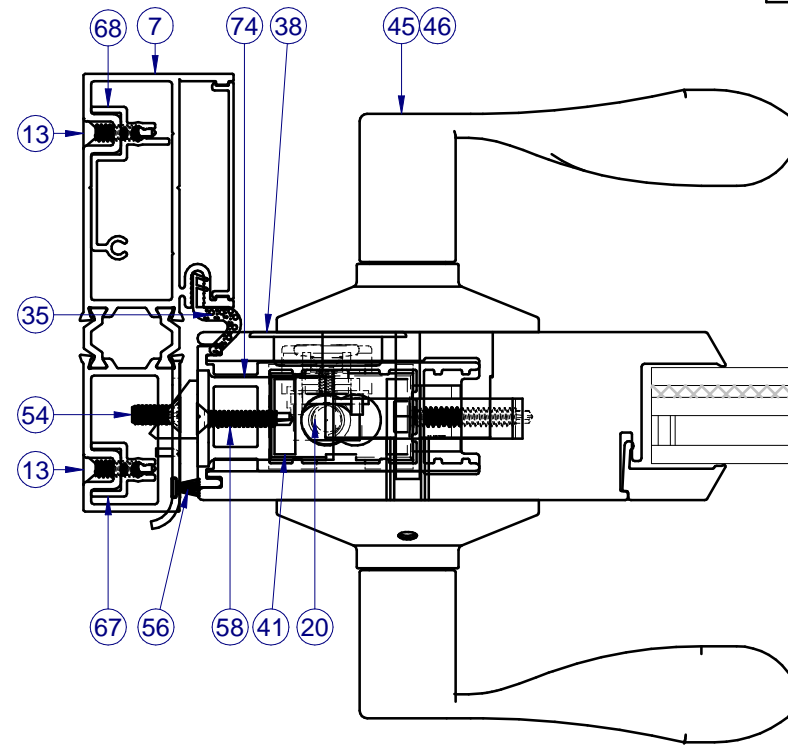

SECTION VIEW B-B

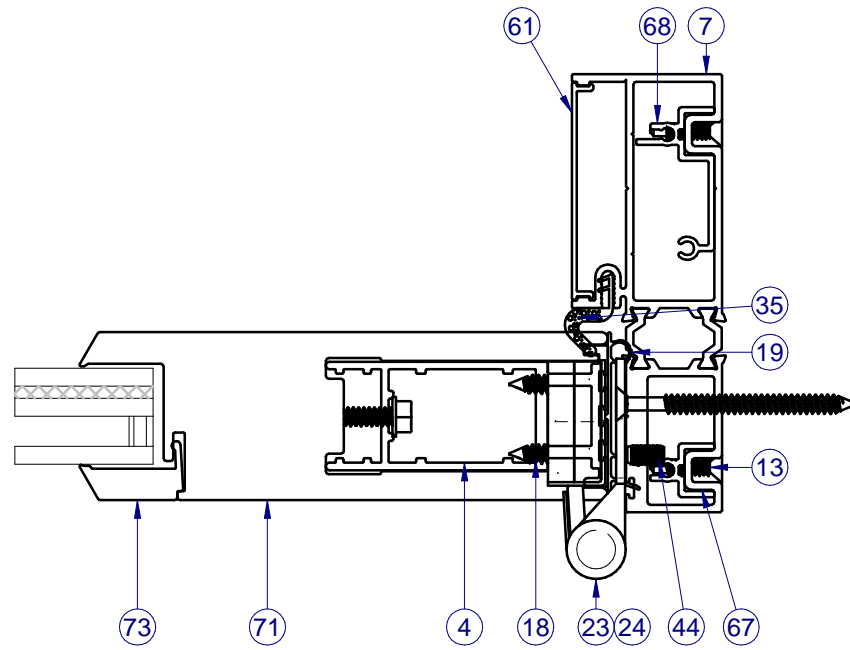

INTERIOR

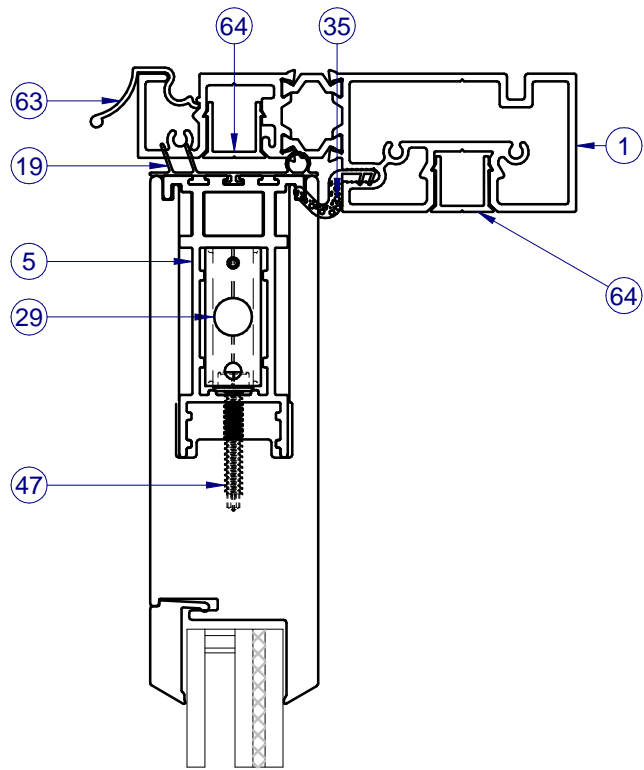

SECTION VIEW A-A

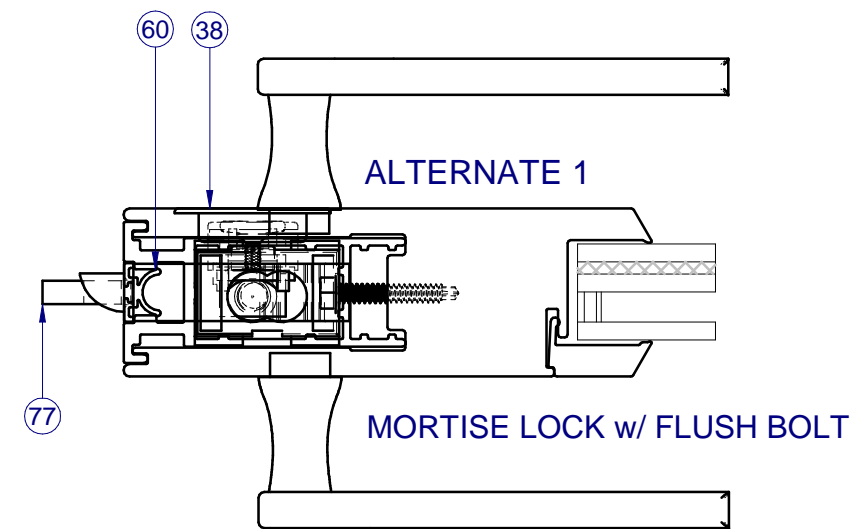
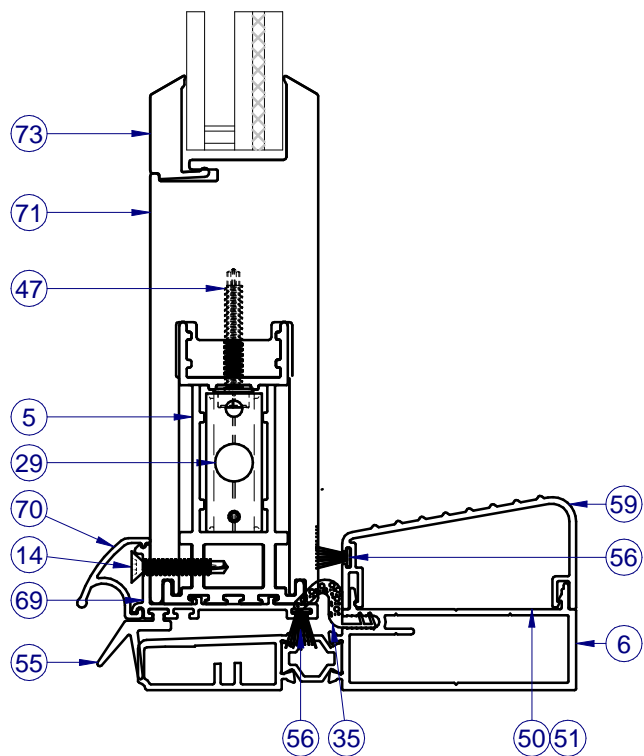

ALTERNATE 1

MORTISE LOCK w/ FLUSH BOLT

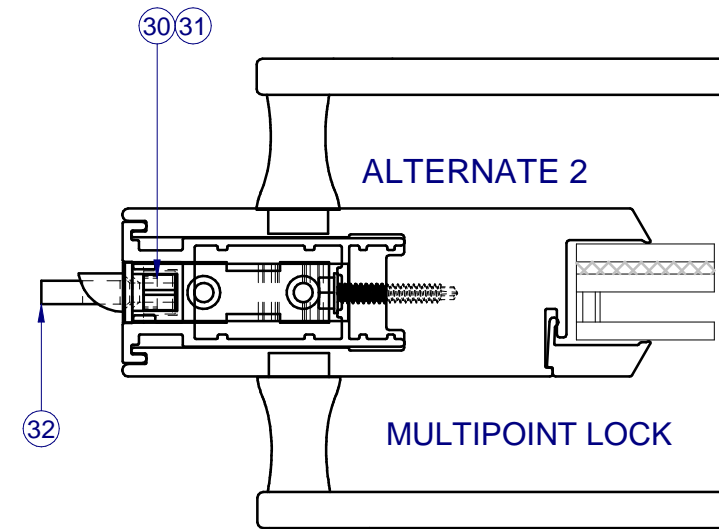

ALTERNATE 2

MULTIPOINT LOCK

ITEMS NOT SHOWN FOR CLARITY:
10-12, 13, 15-17, 22, 43, 48, 54, 57-58

ITEMS NOT USED IN VERSION SHOWN:
2-3, 8-9, 15-16, 25-28, 30-34, 36-40, 43, 52-53, 60, 62, 65-66, 72, 76



1900 SW 44TH AVE.
 OCALA, FLORIDA 34474
 WWW.CWS.CC

**8700/10/50 PVC
 SWING DOOR
 IMPACT**

PROPRIETARY AND CONFIDENTIAL
 THE INFORMATION CONTAINED IN
 THIS DRAWING IS THE SOLE
 PROPERTY OF CUSTOM WINDOW
 SYSTEMS, INC. ANY
 REPRODUCTION IN PART OR AS A
 WHOLE WITHOUT THE WRITTEN
 PERMISSION OF CUSTOM WINDOW
 SYSTEMS, INC IS PROHIBITED.

FLORIDA APPROVAL NO.:

14850

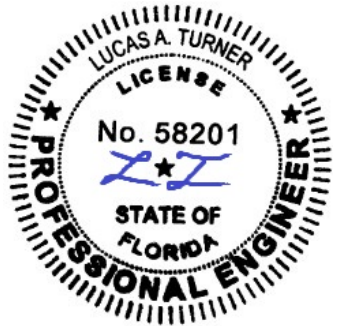

9/25/2023

LUCAS A. TURNER, P.E.
 FL PE # 58201
 Turner Engineering &
 Consulting, Inc.
 2428 Old Natchez Trc Trl
 Camden, TN 38320
 PH. 941-380-1574

SHEET DESCRIPTION:

**SECTION VIEWS
 FRENCH DOOR**

DRAWN BY:	DATE:
MCS	9/20/2023
DWG #:	REV.:
CWS-641	E
SCALE:	SHEET
1:2	6 OF 12

INTERIOR

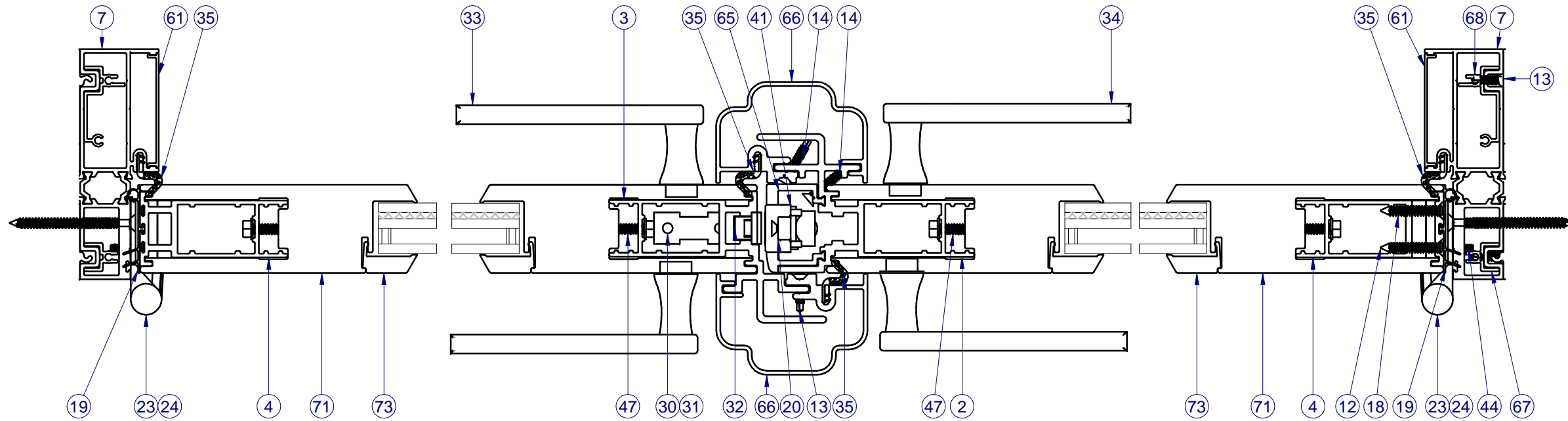

SECTION VIEW C-C

NOTE: VERTICAL SECTION SIMILAR
 TO SINGLE DOOR, SEE SHEET 5

ITEMS NOT SHOWN FOR CLARITY:
 10-13, 15-17, 22, 26-28, 36-39, 43, 54, 57

ITEMS NOT USED IN VERSION SHOWN:
 8-9, 15-16, 25, 40, 42, 45-46, 48, 52-53, 58, 60, 74, 76



1900 SW 44TH AVE.
OCALA, FLORIDA 34474
WWW.CWS.CC

**8700/10/50 PVC
SWING DOOR
IMPACT**

PROPRIETARY AND CONFIDENTIAL
THE INFORMATION CONTAINED IN
THIS DRAWING IS THE SOLE
PROPERTY OF CUSTOM WINDOW
SYSTEMS, INC. ANY
REPRODUCTION IN PART OR AS A
WHOLE WITHOUT THE WRITTEN
PERMISSION OF CUSTOM WINDOW
SYSTEMS, INC IS PROHIBITED.

FLORIDA APPROVAL NO.:

14850



9/25/2023

LUCAS A. TURNER, P.E.
FL PE # 58201
Turner Engineering &
Consulting, Inc.
2428 Old Natchez Trc Trl
Camden, TN 38320
PH. 941-380-1574

SHEET DESCRIPTION:

**SECTION VIEWS
ATTACHED SIDELITE**

DRAWN BY:	DATE:
MCS	9/20/2023
DWG #:	REV.:
CWS-641	E
SCALE:	SHEET
1:2	7 OF 12

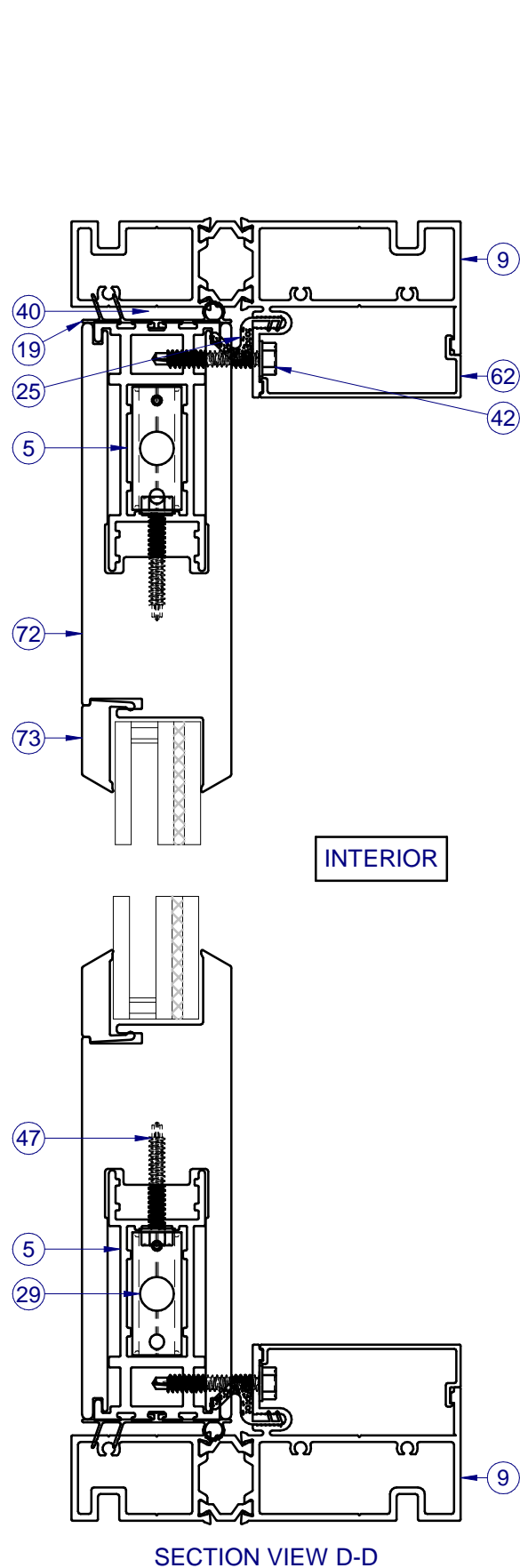

INTERIOR

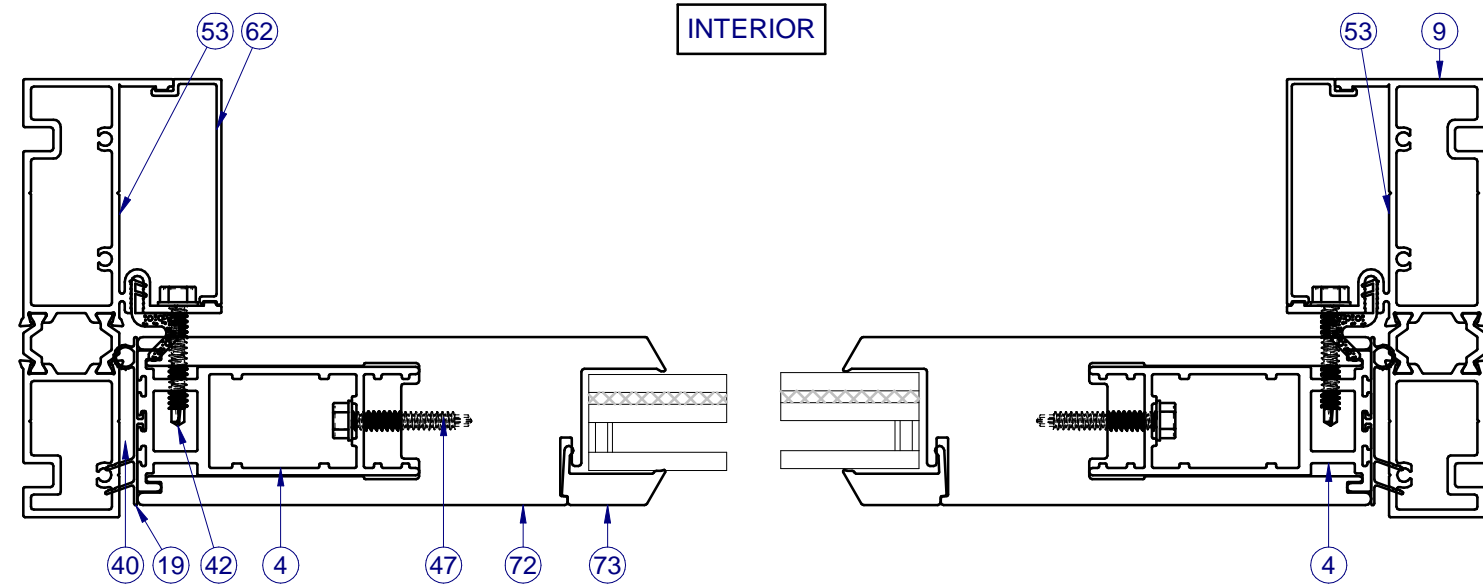

INTERIOR

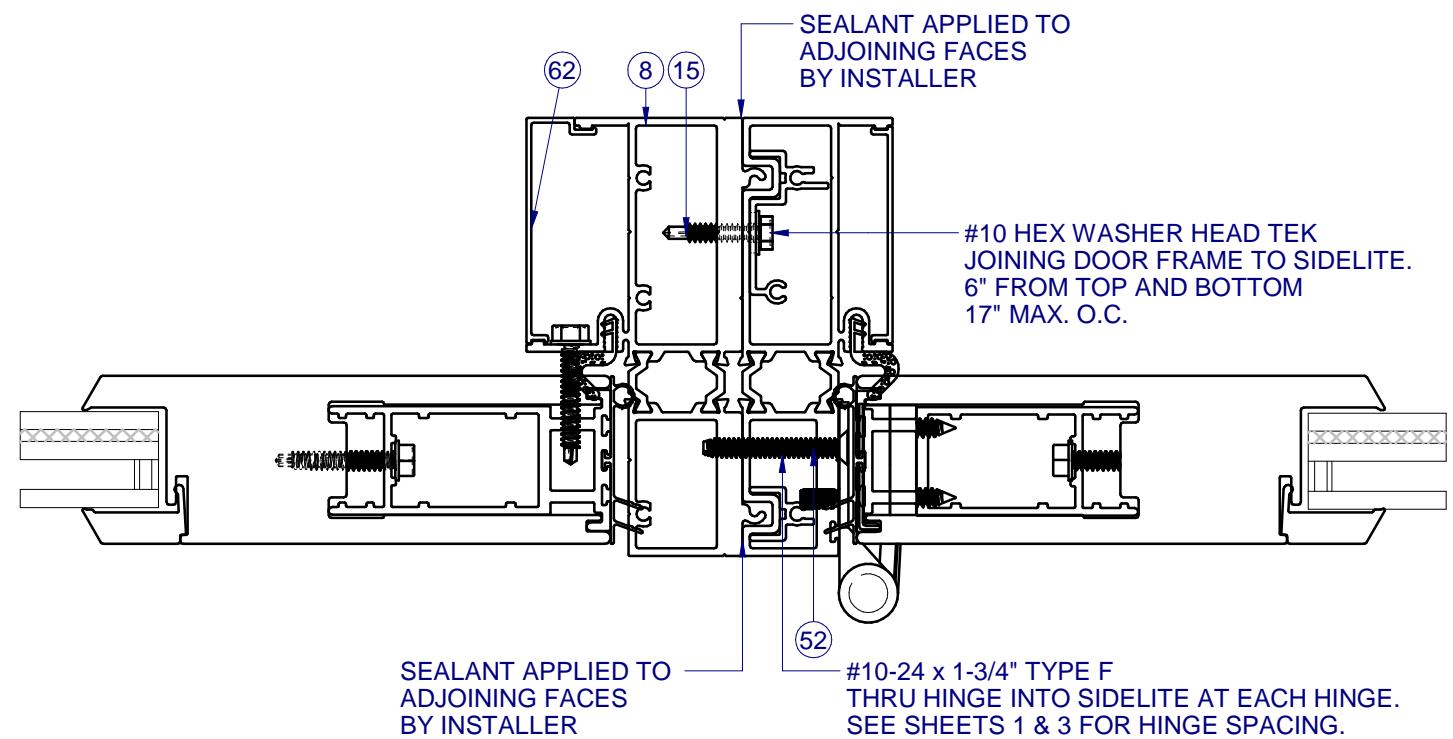

ITEMS NOT SHOWN FOR CLARITY:
10-11, 16, 22, 28, 43, 57

ITEMS NOT USED IN VERSION SHOWN:
1-3, 6-15, 17-18, 20-21, 23-24, 26-27, 30-39, 41, 44-46, 48-52, 54-56, 58-61, 63-71, 74-76

PARTS LIST			
ITEM	PART #	DESCRIPTION	MATERIAL
1	H-1833	MAIN FRAME, HEAD	ALUM
2	H-1857	ASTRAGAL, INACTIVE, FD, PVC	ALUM
3	H-1858	ASTRAGAL, ACTIVE, FD, PVC	ALUM
4	H-1860	REINFORCEMENT, VERT.	ALUM
5	H-1861	REINFORCEMENT, HORIZ	ALUM
6	H-1928	Threshold, Base, T/B, (FD-8700)	ALUM
7	H-1880	MAINFRAME, JAMB	ALUM
8	H-1881	MAINFRAME, SIDELITE @ DOOR	ALUM
9	H-1900	MAINFRAME, SIDELITE @ JAMB, HEAD, SILL	ALUM
10	P-5531	Setting Block, .09 x 1 x 2	RUBBER
11		SIKAFLEX 552 or PURFECT GLAZE "H"	
12	P-3503	SCREW #8 X 1/2" PH TRUSS SS @ ASTRAGAL CAP	
13	P-3511	#8 x 5/8" SQUARE, PH, TEK TYPE AB (GD)/(H/V)	
14	P-3587	#8 x 1" Ph FH TEK	
15	P-3767	SCREW, #10 X 1" HEX HEAD, TEK @ SIDELITE	
16	P-4146	#8 X 3/4" Ph FH Tek	
17	P-4278	FUZZY PAD, .200" x 1.250" W/ADHESIVE	
18	P-4522	#10 X 1 1/4", PH FLAT, SMS - HINGE @ PANEL	
19	P-4774	WSTP, BULB/LEAFS, PANEL	
20	P-4790	FLUSH BOLT, ASSM, TOP/BTM	
22	P-4802	ALL THREADED ROD (TIE ROD)	
23	P-4807	HINGE, GUIDE	
24	P-4808/P4809	HINGE, SET	
25	P-4814	WSTP, .50X.750 FOLDED BULB SEAL, @ SIDELITE	
26	P-4863	LOCK STRIKE PLATE	
27	P-4864	RHINO STRIKE PLATE	
28	P-4866	GUIDE, TIE ROD	
29	P-5344	BRACKET ASSM, 8700 TIE ROD BRACKET	ZINC
30	P-4885	SHOOT BOLT, TOP	
31	P-4886	SHOOT BOLT, BOTTOM	
32	P-4851	LOCKBAR, INACTIVE, 8 FT	
32	P-4884	LOCKBAR, MULTI-POINT, 5PT, 8 FT	
32	P-4901	LOCKBAR, MULTI-POINT, 4PT, 6'8 FT	
32	P-4902	LOCKBAR, INACTIVE, 6'8 FT	
33	P-4903	HANDLE SET, ACTIVE	
34	P-4905	HANDLE SET, INACTIVE	
35	P-4913	WSTP, .50X.50 FOLDED BULB SEAL, @ DOOR	
36	P-4917	CAP, ASTRAGAL, OUTSIDE	NYLON
37	P-5159	Guide, Flush Bolt (8750, use with 1849)	
38	P-4922	COVER, INTERIOR, FLUSH BOLT	NYLON
39	P-4925	CAP, ASTRAGAL, INSIDE	NYLON
40	P-4926	SHIM, SIDELITE, DOOR SHIPPING BLOCK	
41	P-5159	Guide, Flush Bolt (8750, use with 1849)	NYLON
42	P-5219	12-24 x 1-3/4, PHIL FLAT, SS, MS (8710 MULL SCREW)	
43	P-4933	NUT, 3/8"-16 FLANGED W/ SERRATED LIP, SS, @ PANEL	
44	P-4934	SCREW, #12-24x3/4" Machine Screw (Hinge Screw 8700)	
45	P-4936	DOOR KNOB, ACTIVE PANEL *	
46	P-4937	DEADBOLT, ACTIVE PANEL *	
47	P-4969	#10 X 2 Quad Rd. Washer Screw	
48	P-4997	STRIKE, DEADBOLT	
49	P-5127	SCREW, #12 X 2", PH PAN, SMS, ANCHOR	
50	P-5130	GASKET, DOOR SILL, FRONT	FOAM

PARTS LIST			
ITEM	PART #	DESCRIPTION	MATERIAL
51	P-5131	GASKET, DOOR SILL, BACK	FOAM
52	P-5134	SCREW, #10 X 1-3/4" FLAT SQUARE TYPE F @ HINGE	
53	P-5151	GASKET, SIDELITE	FOAM
54	P-5157	SCREW #10-24 x 1/2", FI Undercut PH, 18-8SS @ KEEPER	
55	P-5158	Drip FLAP for 8700 Door	RUBBER
56	P-5172	WSTP, .370 X .187, TRI FIN, BLACK	
57	P-5174	SCREW #8 X 3/4" HEX WASHER HEAD, @ FRAME	
58	P-5186	SCREW #8-32 X 1-1/4" PH, FL MS, SS @ PLUNGER	SS
59	S-1783	THRESHOLD, HIGH RISE	ALUM
60	S-1784	INSERT, REINFORCEMENT	ALUM
61	S-1806	COVER, JAMB, ANCHOR	ALUM
62	S-1816	COVER, JAMBS, HEAD, SILL, SIDELITE	ALUM
63	S-1817	DRIP CAP	ALUM
64	S-1840	COVER, HEAD, ANCHOR	ALUM
65	S-1849	INSERT, INACTIVE PNL, LOCK HARDWARE	
66	S-1859	COVER, ASTRAGAL, FD	ALUM
67	S-1864	INSERT, FRONT, BTM ATTACH SILL	ALUM
68	S-1865	INSERT, BACK, BTM ATTACH SILL	ALUM
69	S-1915	BASE, SWEEP	ALUM
70	S-1916	DRIP COVER, SWEEP	ALUM
71	S-6083	PANEL, TOP/BTM RAIL, SIDES - DOOR	PVC
72	S-6083	PANEL, TOP/BTM RAIL, SIDES - SIDELITE	PVC
73	S-6084	GLAZING BEAD (1")	PVC
74	H-1888	REINFORCEMENT, VERT., SINGLE DOOR	ALUM
75	GLASS	SEE SHEET 4	
76	H-1862	REINFORCEMENT, VERT.	ALUM
77	P-4887	MORTISE LOCK	

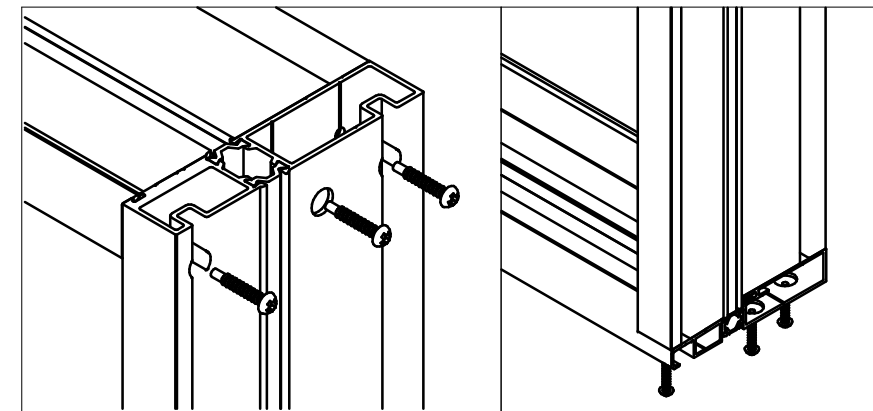

HEAD

SILL

ALL FRAMES ARE MECHANICALLY FASTENED

* ALTERNATE APPROVED LOCKSETS:
PAMEX GRADE 2 LOCKSET AND DEADBOLT



8700/10/50 PVC SWING DOOR IMPACT

PROPRIETARY AND CONFIDENTIAL
THE INFORMATION CONTAINED IN THIS DRAWING IS THE SOLE PROPERTY OF CUSTOM WINDOW SYSTEMS, INC. ANY REPRODUCTION IN PART OR AS A WHOLE WITHOUT THE WRITTEN PERMISSION OF CUSTOM WINDOW SYSTEMS, INC IS PROHIBITED.

FLORIDA APPROVAL NO.:
14850



9/25/2023

LUCAS A. TURNER, P.E.
FL PE # 58201
Turner Engineering & Consulting, Inc.
2428 Old Natchez Trc Trl
Camden, TN 38320
PH. 941-380-1574

SHEET DESCRIPTION:

BOM

DRAWN BY: MCS	DATE: 9/20/2023
DWG #: CWS-641	REV.: E
SCALE: 1:1	SHEET 8 OF 12

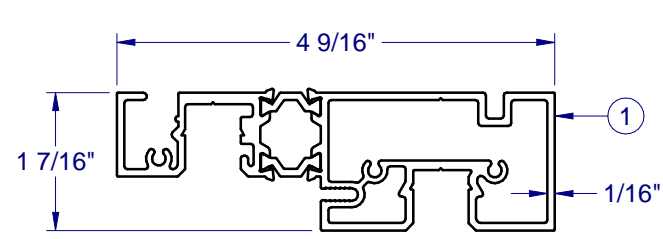

DOOR HEAD-1833

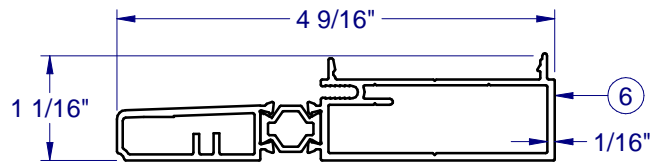

DOOR SILL-1928

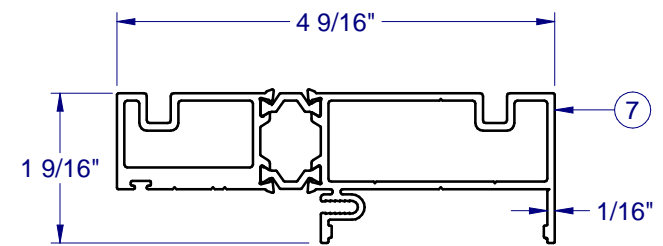

DOOR JAMB-1880

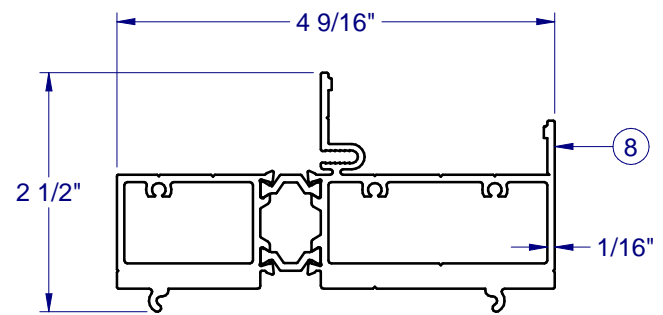

SIDELITE-1881

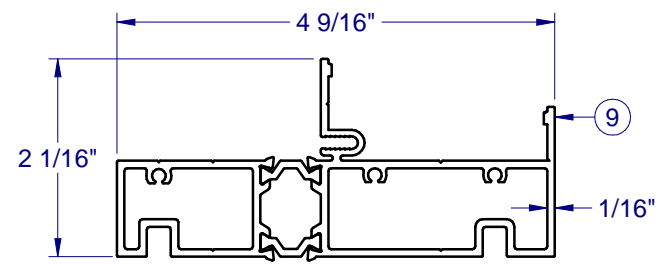

SIDELITE-1900

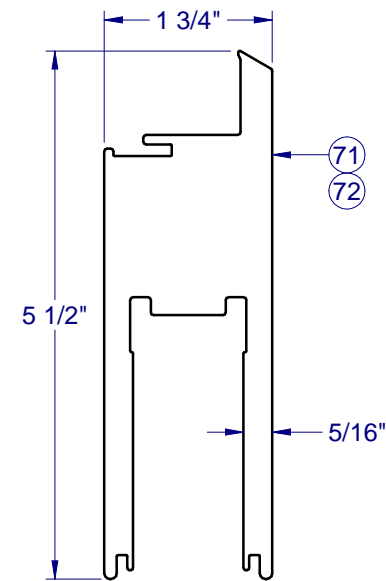

PVC DOOR PANEL - 6083

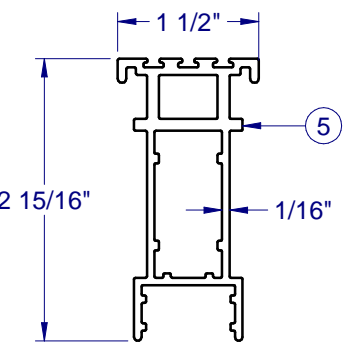

REINFORCEMENT - 1861

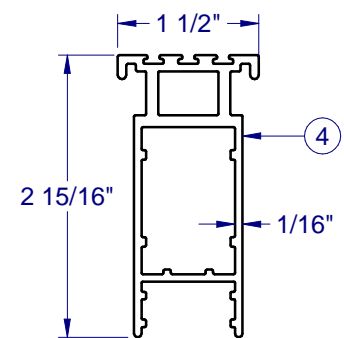

REINFORCEMENT-1860

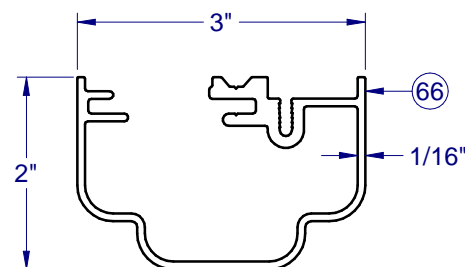

ASTRAGAL COVER-1859

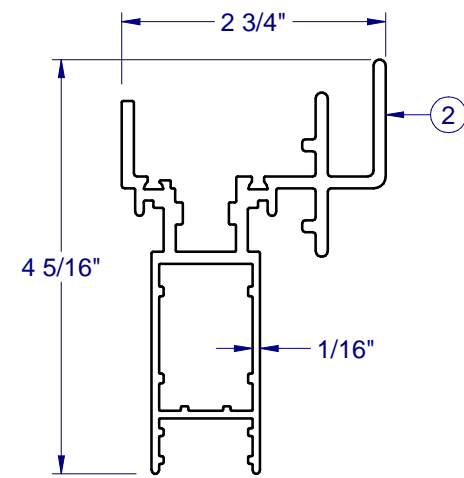

REINFORCEMENT - 1857

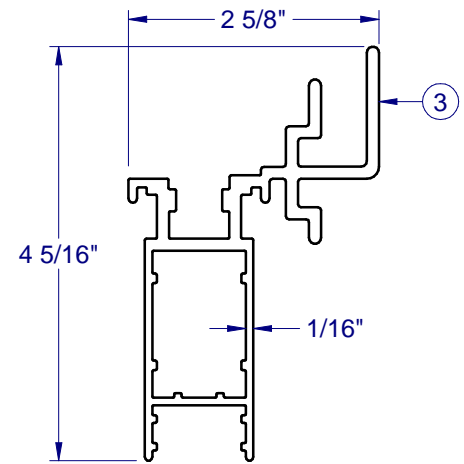

REINFORCEMENT - 1858

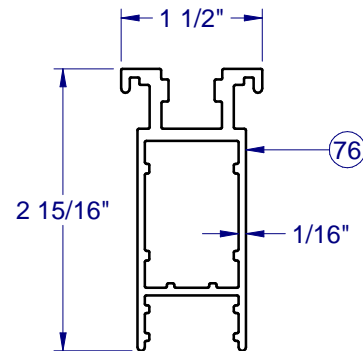

REINFORCEMENT - 1862

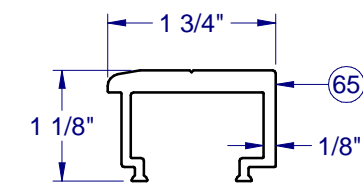

INSERT, INACTIVE PNL - 1849

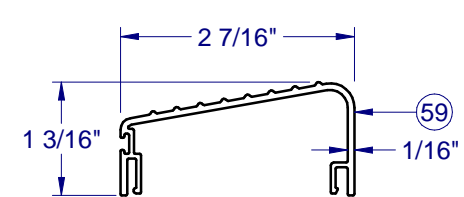

THRESHOLD - 1783

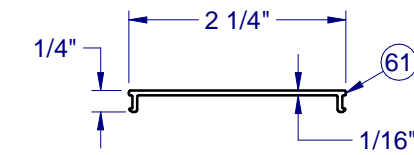

FRAME COVER - 1806

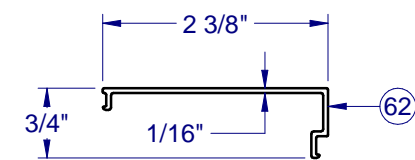

SIDELITE COVER - 1816

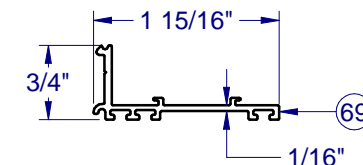

BASE SWEEP - 1915

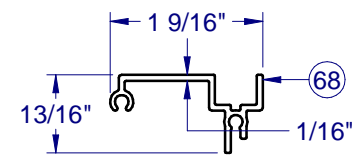

INSERT, BACK - 1865

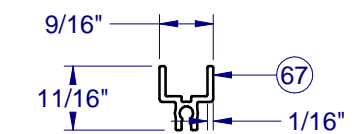

INSERT, FRONT - 1864

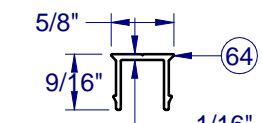

HEAD COVER - 1840

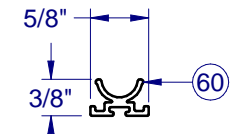

FILLER - 1784

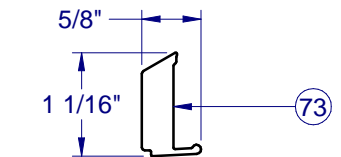

PVC GLAZING BEAD - 6084

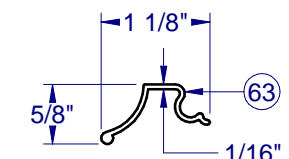

DRIP CAP - 1817

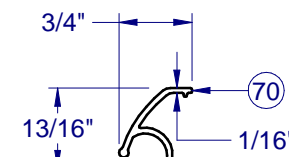

DRIP COVER - 1916



1900 SW 44TH AVE.
OCALA, FLORIDA 34474
WWW.CWS.CC

8700/10/50 PVC SWING DOOR IMPACT

PROPRIETARY AND CONFIDENTIAL
THE INFORMATION CONTAINED IN THIS DRAWING IS THE SOLE PROPERTY OF CUSTOM WINDOW SYSTEMS, INC. ANY REPRODUCTION IN PART OR AS A WHOLE WITHOUT THE WRITTEN PERMISSION OF CUSTOM WINDOW SYSTEMS, INC IS PROHIBITED.

FLORIDA APPROVAL NO.:
14850



9/25/2023

LUCAS A. TURNER, P.E.
FL PE # 58201
Turner Engineering & Consulting, Inc.
2428 Old Natchez Trc Trl
Camden, TN 38320
PH. 941-380-1574

SHEET DESCRIPTION:

EXTRUSIONS

DRAWN BY:	DATE:
MCS	9/20/2023
DWG #:	REV.:
CWS-641	E
SCALE:	SHEET
1:2	9 OF 12

NOTE: ALL ALUMINUM EXTRUSIONS ARE 6063-T6 ALUMINUM

**8700/10/50 PVC
SWING DOOR
IMPACT**

PROPRIETARY AND CONFIDENTIAL
THE INFORMATION CONTAINED IN
THIS DRAWING IS THE SOLE
PROPERTY OF CUSTOM WINDOW
SYSTEMS, INC. ANY
REPRODUCTION IN PART OR AS A
WHOLE WITHOUT THE WRITTEN
PERMISSION OF CUSTOM WINDOW
SYSTEMS, INC IS PROHIBITED.

FLORIDA APPROVAL NO.:

14850

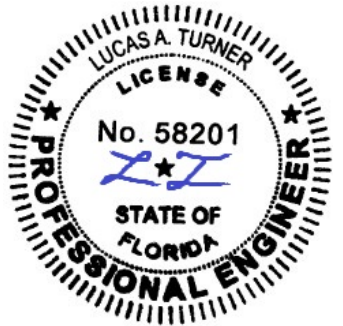

9/25/2023

LUCAS A. TURNER, P.E.
FL PE # 58201
Turner Engineering &
Consulting, Inc.
2428 Old Natchez Trc Trl
Camden, TN 38320
PH. 941-380-1574

SHEET DESCRIPTION:

**ANCHOR SCHEDULE AND
NOTES**

DRAWN BY: MCS	DATE: 9/20/2023
DWG #: CWS-641	REV.: E
SCALE: 1:35	SHEET 10 OF 12

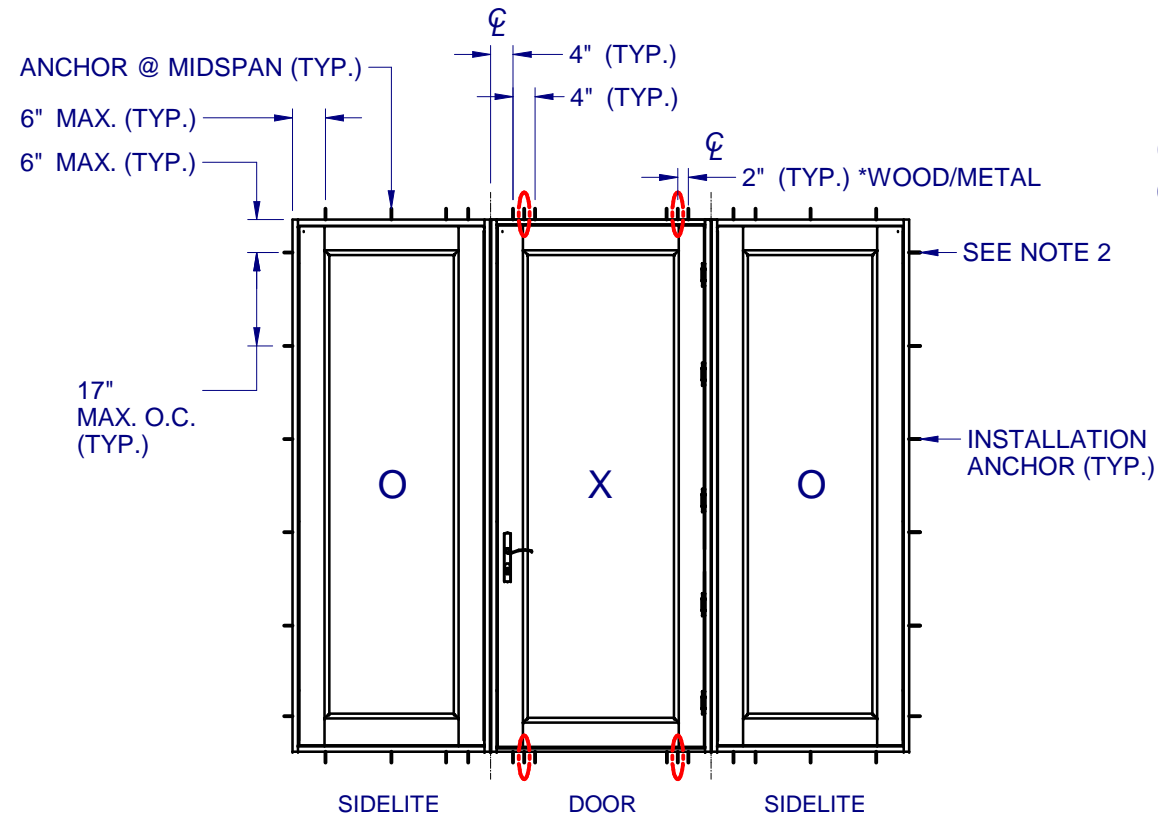

ANCHOR LAYOUT - (FLANGE)

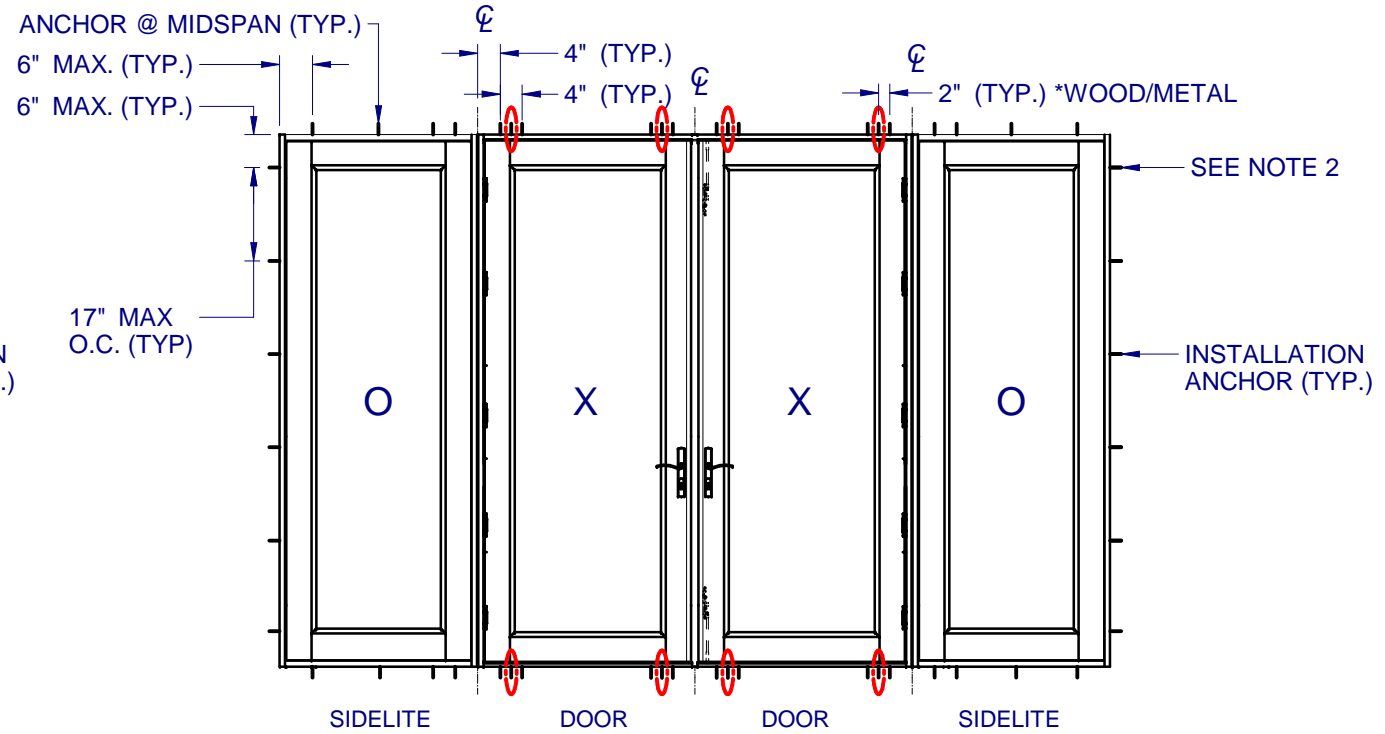

ANCHOR LAYOUT - (FLANGE)

*** CIRCLED ANCHOR LOCATIONS REQ'D ONLY IN WOOD AND METAL INSTALLATIONS. DO NOT INSTALL THESE ANCHORS INTO MASONRY.**

NOTES:

1. INSTALL ONE ANCHOR AT EACH INSTALLATION LOCATION. SILL ANCHOR SPACING SAME AS HEAD.
2. SHIM AS REQ AT EACH INSTALLATION ANCHOR USING LOAD BEARING SHIMS. MAX. ALLOWABLE SHIM STACK TO BE 1/4". USE SHIMS WHERE SPACE GREATER THAN 1/16" IS PRESENT. LOAD BEARING SHIMS SHALL BE CONSTRUCTED OF HIGH DENSITY PLASTIC OR BETTER. WOOD SHIMS ARE NOT ALLOWED.
3. ANCHOR TYPE, SIZE, SPACING AND EMBEDMENT SHALL BE AS SPECIFIED IN THESE DRAWINGS, SEE TABLE 1, SHEET 11.
4. ALL INSTALLATION ANCHORS MUST BE MADE OF OR PROTECTED WITH A CORROSION RESISTANT MATERIAL OR COATING. DISSIMILAR METALS OR MATERIALS IN CONTACT WITH PRESSURE TREATED WOOD MUST BE PROTECTED TO PREVENT REACTION.
5. INSTALLATION ANCHORS SHALL BE IN ACCORDANCE WITH ANCHOR MANUFACTURER'S INSTALLATION INSTRUCTIONS, AND ANCHORS SHALL NOT BE USED IN SUBSTRATES WITH STRENGTHS LESS THAN THE MINIMUM SPECIFIED IN TABLE 1, SHEET 11.
6. ANCHOR EMBEDMENT TO SUBSTRATE SHALL BE BEYOND WALL DRESSING OR STUCCO. FOR CONCRETE/CMU OPENINGS, EMBEDMENT SHALL BE BEYOND WOOD BUCKS, IF USED, INTO SUBSTRATE. INSTALLATIONS TO SOLID CONCRETE OR GROUT-FILLED CMU MAY INCLUDE BUT DO NOT REQUIRE 1X WOOD BUCKS BETWEEN THE PRODUCT AND SUBSTRATE. INSTALLATIONS TO HOLLOW CMU REQUIRE THE USE OF 1X BUCKS BETWEEN THE PRODUCT AND SUBSTRATE.
7. A MINIMUM CENTER-TO-CENTER SPACING SHALL BE MAINTAINED BETWEEN ALL FASTENERS: 4" FOR MASONRY, 2-3/16" FOR HINGES (ALL SUBSTRATES), 1" FOR WOOD AND METAL.
8. WOOD OR MASONRY OPENINGS, BUCKS AND BUCK FASTENERS SHALL BE PROPERLY DESIGNED BY THE ARCHITECT OR ENGINEER OF RECORD AND INSTALLED TO TRANSFER WIND LOADS TO THE STRUCTURE. SUBSTRATES SHALL MEET THE MINIMUM STRENGTH REQUIREMENTS AS SHOWN IN TABLE 1, SHEET 11. CONCRETE AND MASONRY SUBSTRATES MAY NOT BE CRACKED.
9. SEALING AND FLASHING STRATEGIES FOR OVERALL WATER RESISTANCE OF INSTALLATION SHALL BE DONE BY OTHERS FOLLOWING THE CURRENT VERSION OF THE REFERENCE DOCUMENTS: FMA/AAMA 100(FIN WINDOWS), FMA/AAMA 200(FLANGE WINDOWS), FMA/WDMA 250(BOX WINDOWS), FMA/AAMA/WDMA 300(EXTERIOR DOORS)

**8700/10/50 PVC
SWING DOOR
IMPACT**

PROPRIETARY AND CONFIDENTIAL
THE INFORMATION CONTAINED IN THIS DRAWING IS THE SOLE PROPERTY OF CUSTOM WINDOW SYSTEMS, INC. ANY REPRODUCTION IN PART OR AS A WHOLE WITHOUT THE WRITTEN PERMISSION OF CUSTOM WINDOW SYSTEMS, INC IS PROHIBITED.

FLORIDA APPROVAL NO.:
14850



9/25/2023

LUCAS A. TURNER, P.E.
FL PE # 58201
Turner Engineering & Consulting, Inc.
2428 Old Natchez Trc Trl
Camden, TN 38320
PH. 941-380-1574

SHEET DESCRIPTION:
**INSTALLATION DETAILS
DOOR**

DRAWN BY: MCS	DATE: 9/20/2023
DWG #: CWS-641	REV.: E
SCALE: 1:2	SHEET 11 OF 12

TYPICAL HEAD ANCHORAGE

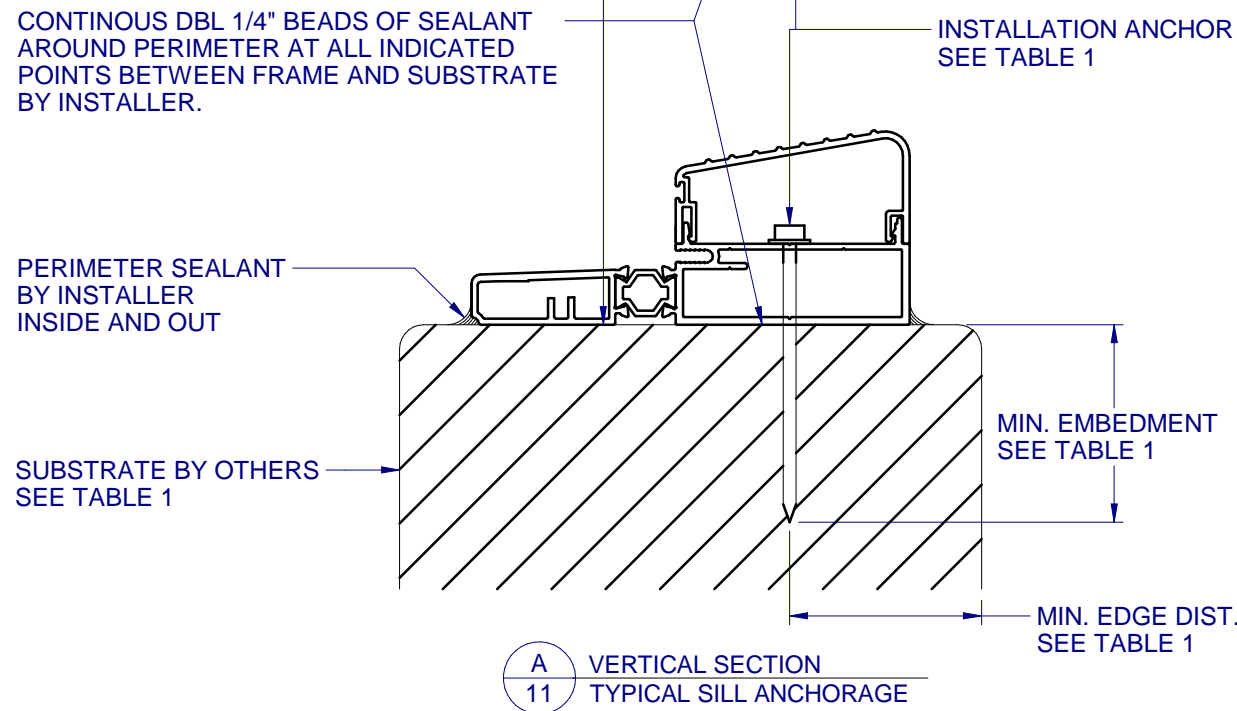
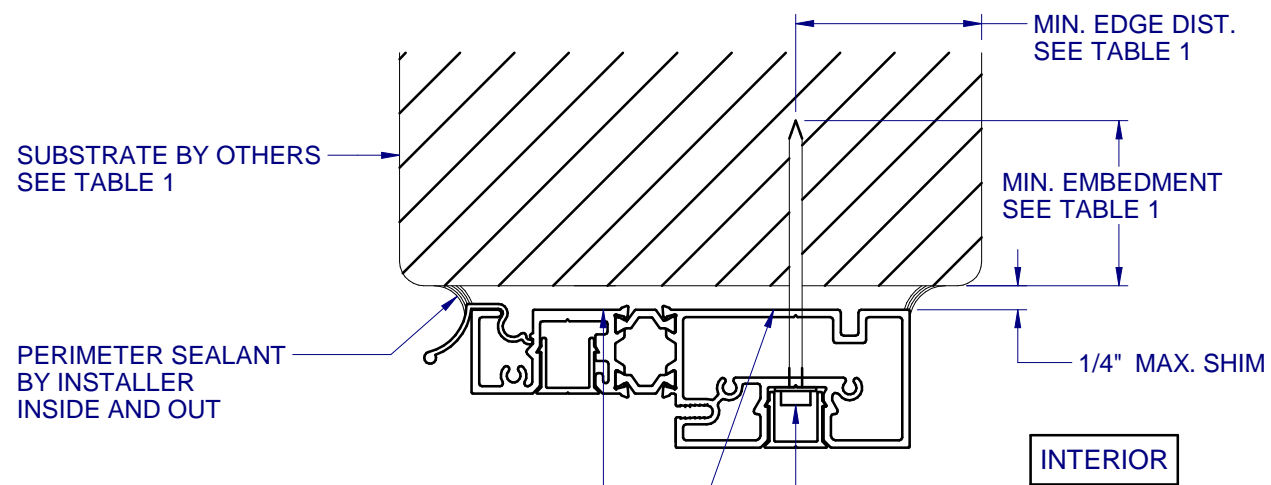

CONTINUOUS DBL 1/4" BEADS OF SEALANT AROUND PERIMETER AT ALL INDICATED POINTS BETWEEN FRAME AND SUBSTRATE BY INSTALLER.

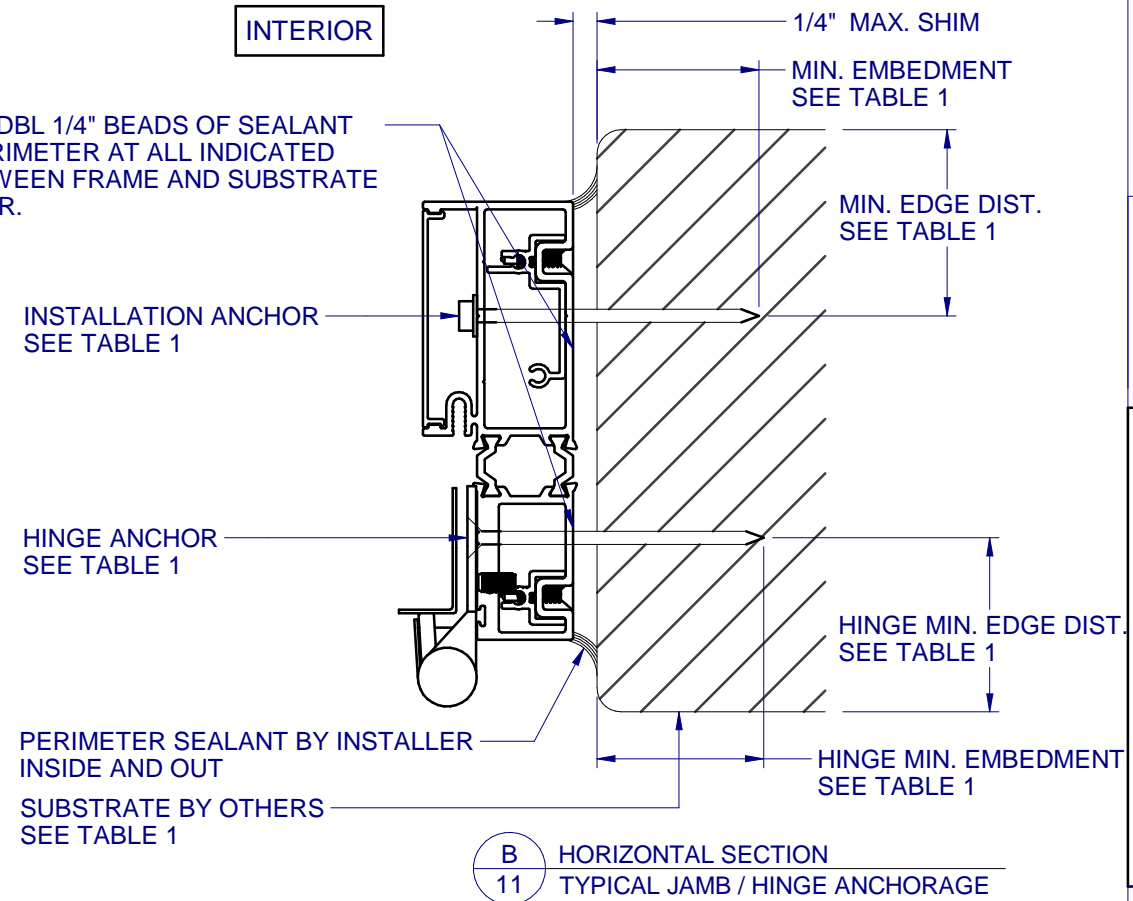

B
11 HORIZONTAL SECTION
TYPICAL JAMB / HINGE ANCHORAGE

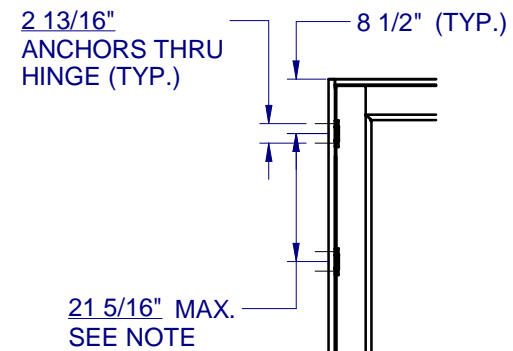

HINGE LAYOUT
1:30

NOTE:
HINGE SPACINGS ARE:
8-1/2" FROM ENDS
21-5/16" MAX. O.C. FOR UP TO 81" UNIT HEIGHT.
20" MAX. O.C. FOR OVER 81" UNIT HEIGHT.

TABLE 1: APPROVED INSTALLATION FASTENERS

SUBSTRATE TYPE	ANCHOR TYPE	MIN. EMBEDMENT	MIN. EDGE DIST.
CONCRETE (3.05 KSI MIN.)	1/4" DEWALT ULTRACON+	1-3/4"	2-1/2"
HOLLOW OR GROUT-FILLED CMU (ASTM C-90)	1/4" DEWALT ULTRACON+	1-1/4"	2-1/2"
2X MIN. SOUTHERN PINE (G=0.55)	1/4" DEWALT ULTRACON+	1-3/8"	7/8"
2X MIN. SOUTHERN PINE (G=0.55)	#12 WOOD SCREW	1-3/8"	7/8"
16 GAUGE (0.060") MIN. STEEL STUD (33 KSI YIELD MIN)	#12-14 HILTI KWIK-FLEX OR ITW TEKS SELF-DRILLING SCREW	FULL THREAD THRU 0.060"	1/2"
1/8" ALUM. (6063-T5 MIN.) OR 1/8" STEEL (33 KSI MIN.)	#12 GRADE 5 SELF-TAPPING / DRILLING SCREW	FULL THREAD THRU 0.125"	1/2"
HINGE ANCHORS INTO CONCRETE (3.05 KSI MIN.)	3/16" DEWALT ULTRACON+	1-3/4"	2-1/2"
HINGE ANCHORS INTO HOLLOW OR GROUT-FILLED CMU (ASTM C-90)	3/16" DEWALT ULTRACON+	1-1/4"	2-1/2"
HINGE ANCHORS INTO 2X MIN. SOUTHERN PINE (G=0.55)	#10 WOOD SCREW	1-3/8"	7/8"
HINGE ANCHORS INTO 16 GAUGE (0.060") MIN. STEEL STUD (33 KSI YIELD MIN)	#10-16 HILTI KWIK-FLEX OR ITW TEKS SELF-DRILLING SCREW	FULL THREAD THRU 0.060"	1/2"
HINGE ANCHORS 1/8" ALUM. (6063-T5 MIN.) OR 1/8" STEEL (33 KSI MIN.)	#10 GRADE 5 SELF-TAPPING / DRILLING SCREW	FULL THREAD THRU 0.125"	1/2"

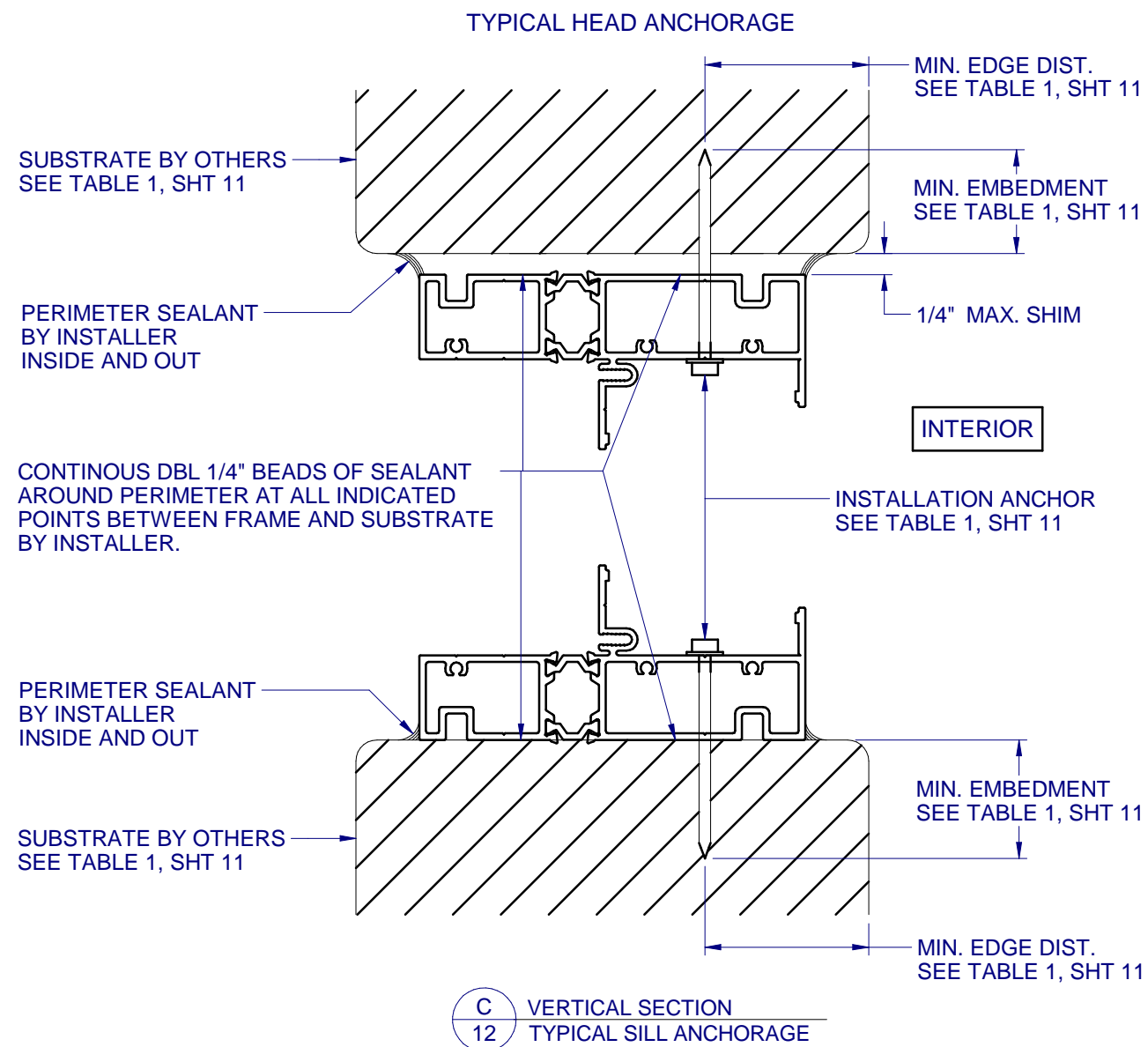

C VERTICAL SECTION
12 TYPICAL SILL ANCHORAGE

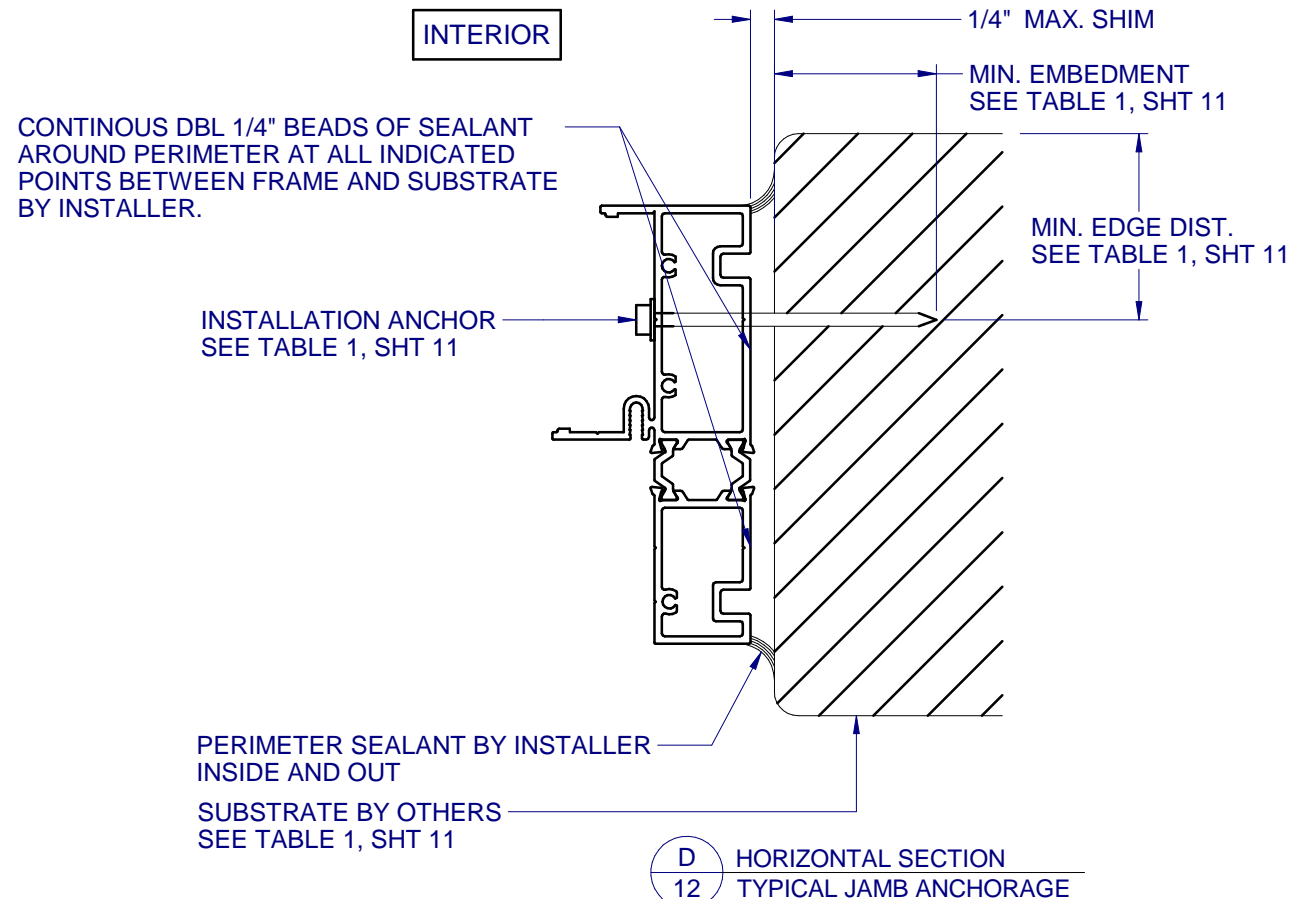

D HORIZONTAL SECTION
12 TYPICAL JAMB ANCHORAGE

**8700/10/50 PVC
SWING DOOR
IMPACT**

PROPRIETARY AND CONFIDENTIAL
THE INFORMATION CONTAINED IN THIS DRAWING IS THE SOLE PROPERTY OF CUSTOM WINDOW SYSTEMS, INC. ANY REPRODUCTION IN PART OR AS A WHOLE WITHOUT THE WRITTEN PERMISSION OF CUSTOM WINDOW SYSTEMS, INC IS PROHIBITED.

FLORIDA APPROVAL NO.:
14850

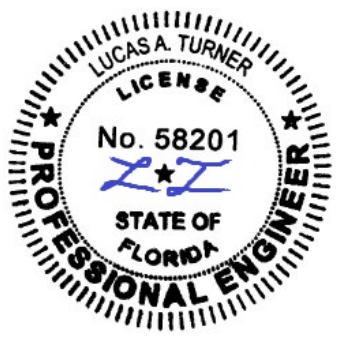

9/25/2023
LUCAS A. TURNER, P.E.
FL PE # 58201
Turner Engineering & Consulting, Inc.
2428 Old Natchez Trc Trl
Camden, TN 38320
PH. 941-380-1574

SHEET DESCRIPTION:
**INSTALLATION DETAILS
SIDELITE**

DRAWN BY: MCS	DATE: 9/20/2023
DWG #: CWS-641	REV.: E
SCALE: 1:2	SHEET 12 OF 12