

AWNING - NON-IMPACT

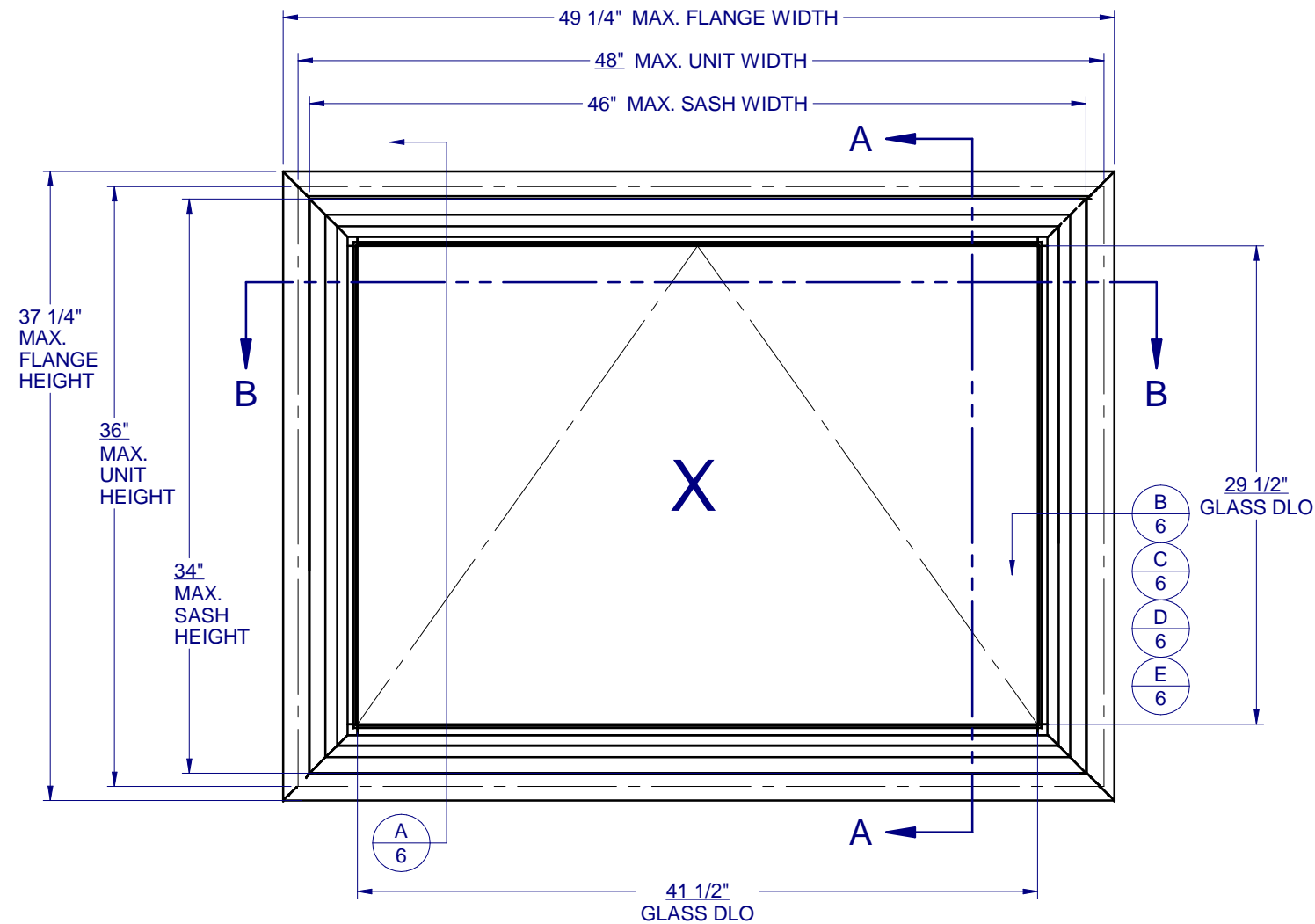

GENERAL NOTES:

1. THE PRODUCT SHOWN HEREIN IS DESIGNED AND MANUFACTURED TO COMPLY WITH THE FLORIDA BUILDING CODE (FBC), CURRENT EDITION AND IS RATED FOR USE IN THE HIGH VELOCITY HURRICANE ZONE (HVHZ).
2. GLAZING OPTIONS: (SEE SHEET 2)
3. CONFIGURATIONS: "X". ALL WINDOWS OPEN FROM BOTTOM TO OUTSIDE.
4. DESIGN PRESSURE RATING (SEE SHEET 2):
 -NEGATIVE DESIGN LOADS BASED ON, TESTED PRESSURE AND GLASS TABLES ASTM E-1300-04e01/09.
 -POSITIVE DESIGN LOADS BASED ON, TESTED PRESSURE, WATER INFILTRATION TEST PRESSURE AND GLASS TABLES ASTM E-1300-04e01/09.
5. ANCHORAGE: THE 33 1/3% STRESS INCREASE HAS NOT BEEN USED IN THE DESIGN OF THIS PRODUCT. SEE SHEET 6 FOR ANCHOR DETAILS. WINDLOAD DURATION FACTOR Cd=1.6 WAS USED FOR WOOD ANCHOR CALCULATIONS.
6. NOT APPROVED FOR IMPACT RESISTANCE. IMPACT PROTECTIVE SYSTEM IS REQUIRED IN WIND BORNE DEBRIS REGION.
7. ALL FRAMES AND VENTS FULLY WELDED.
8. SERIES / MODEL DESIGNATION AW-8450.
9. THE DESIGNATION X AND O STAND FOR THE FOLLOWING:
 X = OPERABLE SASH



8450 PVC AWNING NON-IMPACT

PROPRIETARY AND CONFIDENTIAL
 THE INFORMATION CONTAINED IN THIS DRAWING IS THE SOLE PROPERTY OF CUSTOM WINDOW SYSTEMS, INC. ANY REPRODUCTION IN PART OR AS A WHOLE WITHOUT THE WRITTEN PERMISSION OF CUSTOM WINDOW SYSTEMS, INC IS PROHIBITED.

FLORIDA APPROVAL NO.:
 15032



8/17/2023

LUCAS A. TURNER, P.E.
 FL PE # 58201
 Turner Engineering & Consulting, Inc.
 2428 Old Natchez Trc Trl
 Camden, TN 38320
 PH. 941-380-1574

SHEET DESCRIPTION:
 GENERAL NOTES AND ELEVATIONS

DRAWN BY: MCS	DATE: 8/10/2023
DWG #: CWS-652	REV.: E
SCALE: 1:10	SHEET 1 OF 6

TABLE OF CONTENTS

GENERAL NOTES & ELEVATIONS.....	1
COMP. ANALYSIS AND GLAZING DETAILS....	2
SECTION VIEWS.....	3
BOM & EXTRUSIONS.....	4
ANCHOR SCHEDULE & NOTES.....	5
INSTALLATION DETAILS.....	6

MAX. UNIT SIZE	DESIGN PRESSURE RATING	IMPACT RATING
48" x 36"	SEE COMPARATIVE ANALYSIS CHART, SHEET 2	NONE

DESIGN PRESSURES (PSF) FOR "X" CONFIGURATION

Unit	Glass	Unit Height (in.)					
		17 7/8	23 1/2	29 1/2	31 1/2	35 1/2	36
20	A, B	+70.0 / -101.3	+70.0 / -101.3	+70.0 / -101.3	+70.0 / -101.3	+70.0 / -85.8	+70.0 / -84.1
23 1/2	A, B	+70.0 / -101.3	+70.0 / -101.3	+70.0 / -101.3	+70.0 / -94.2	+70.0 / -78.4	+70.0 / -76.8
27 1/2	A, B	+70.0 / -101.3	+70.0 / -101.3	+70.0 / -101.0	+70.0 / -89.6	+70.0 / -73.1	+70.0 / -71.5
29 1/2	A, B	+70.0 / -101.3	+70.0 / -101.3	+70.0 / -100.5	+70.0 / -88.5	+70.0 / -71.5	+69.8 / -69.8
31 1/2	A, B	+70.0 / -101.3	+70.0 / -101.3	+70.0 / -100.5	+70.0 / -88.2	+70.0 / -70.3	+68.6 / -68.6
35 1/2	A, B	+70.0 / -101.3	+70.0 / -101.3	+70.0 / -100.5	+70.0 / -88.2	+69.4 / -69.4	+67.5 / -67.5
41 1/2	A, B	+70.0 / -101.3	+70.0 / -101.3	+70.0 / -92.4	+70.0 / -88.2	+69.4 / -69.4	+67.5 / -67.5
48	A, B	+70.0 / -101.3	+70.0 / -85.6	+70.0 / -74.3	+70.0 / -71.8	+67.9 / -67.9	+67.5 / -67.5

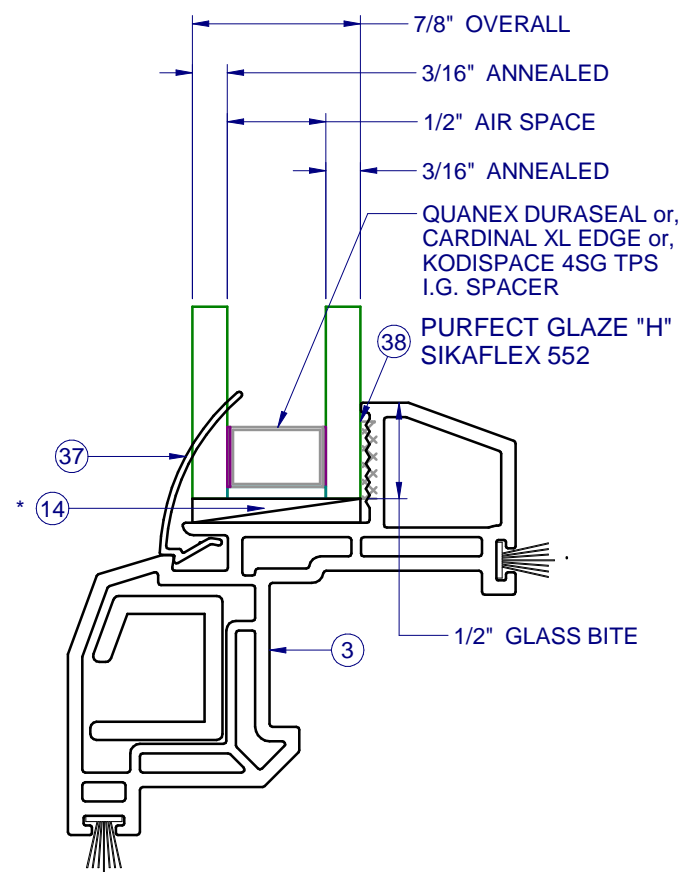

GLASS TYPE A

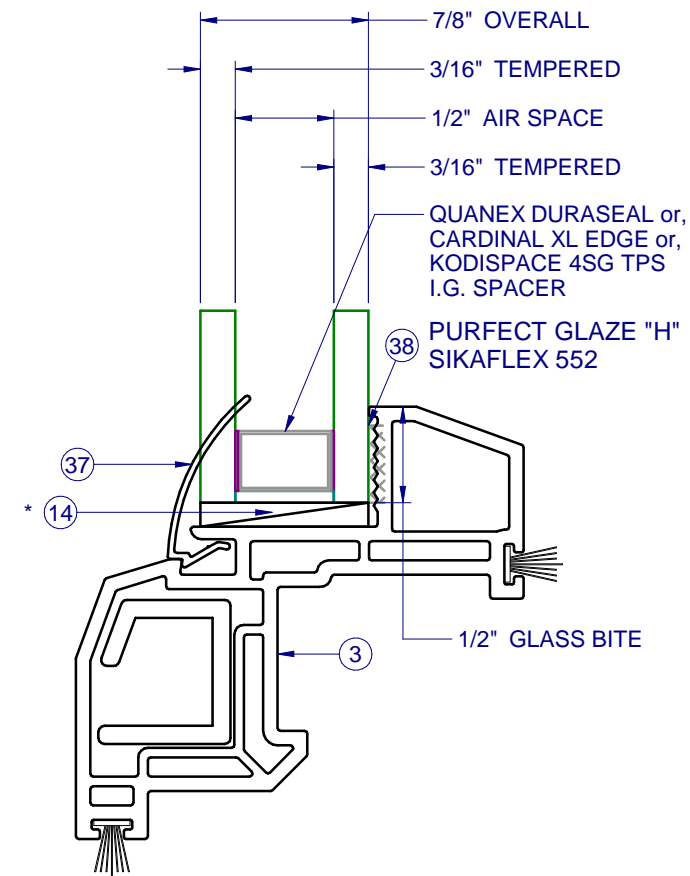

GLASS TYPE B

* SETTING BLOCKS PER FBC 2411.3.3.1

NOTE: IF SIZE INTENDED IS NOT SHOWN, USE NEXT LARGER SIZE.



1900 SW 44TH AVE.
OCALA, FLORIDA 34474
WWW.CWS.CC

**8450 PVC
AWNING
NON-IMPACT**

PROPRIETARY AND CONFIDENTIAL
THE INFORMATION CONTAINED IN
THIS DRAWING IS THE SOLE
PROPERTY OF CUSTOM WINDOW
SYSTEMS, INC. ANY
REPRODUCTION IN PART OR AS A
WHOLE WITHOUT THE WRITTEN
PERMISSION OF CUSTOM WINDOW
SYSTEMS, INC IS PROHIBITED.

FLORIDA APPROVAL NO.:

15032



8/17/2023

LUCAS A. TURNER, P.E.
FL PE # 58201
Turner Engineering &
Consulting, Inc.
2428 Old Natchez Trc Trl
Camden, TN 38320
PH. 941-380-1574

SHEET DESCRIPTION:

**COMPARATIVE ANALYSIS
AND GLAZING DETAILS**

DRAWN BY:	DATE:
MCS	8/10/2023
DWG #:	REV.:
CWS-652	E
SCALE:	SHEET
1:1	2 OF 6



1900 SW 44TH AVE.
OCALA, FLORIDA 34474
WWW.CWS.CC

**8450 PVC
AWNING
NON-IMPACT**

PROPRIETARY AND CONFIDENTIAL
THE INFORMATION CONTAINED IN
THIS DRAWING IS THE SOLE
PROPERTY OF CUSTOM WINDOW
SYSTEMS, INC. ANY
REPRODUCTION IN PART OR AS A
WHOLE WITHOUT THE WRITTEN
PERMISSION OF CUSTOM WINDOW
SYSTEMS, INC IS PROHIBITED.

FLORIDA APPROVAL NO.:

15032



8/17/2023

LUCAS A. TURNER, P.E.
FL PE # 58201
Turner Engineering &
Consulting, Inc.
2428 Old Natchez Trc Trl
Camden, TN 38320
PH. 941-380-1574

SHEET DESCRIPTION:

SECTION VIEWS

DRAWN BY:	DATE:
MCS	8/10/2023
DWG #:	REV.:
CWS-652	E
SCALE:	SHEET
1:2	3 OF 6

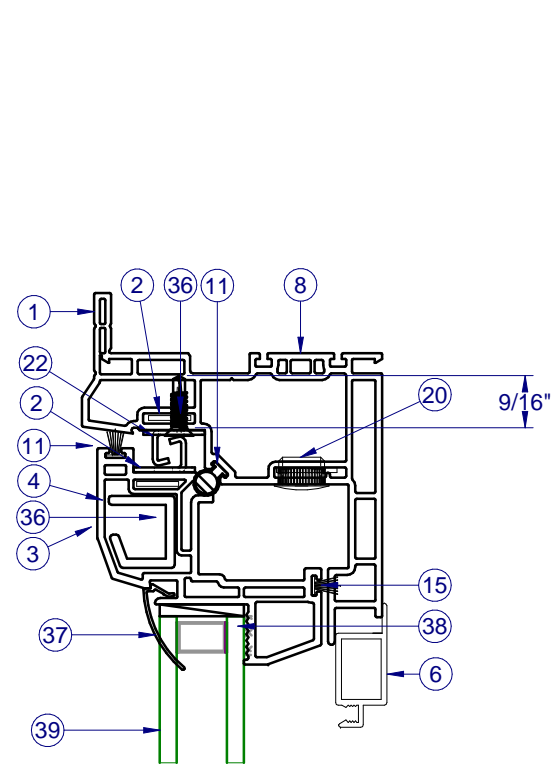

SECTION VIEW A-A

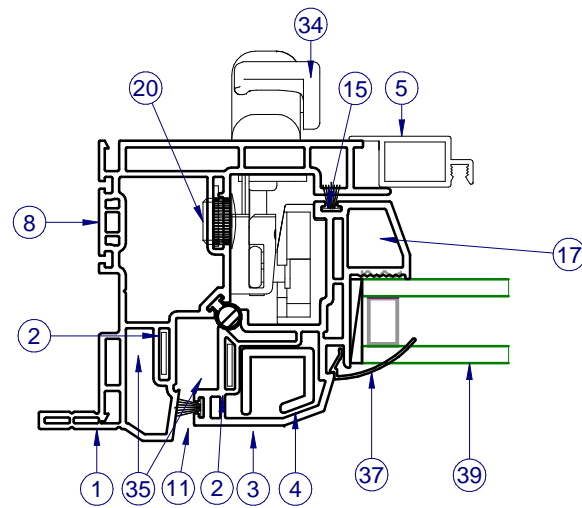

INTERIOR

SECTION VIEW B-B

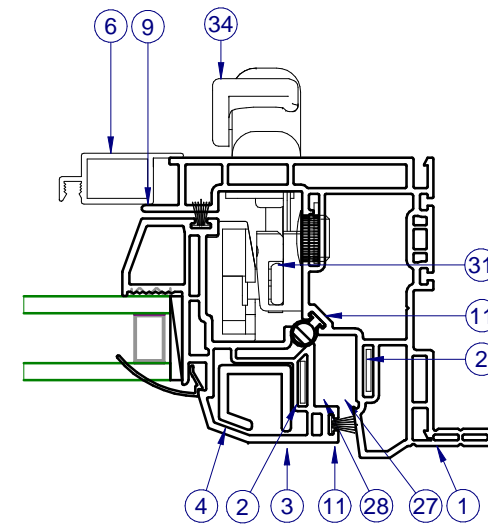

INTERIOR

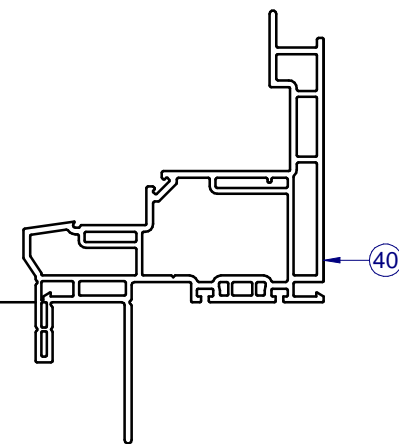
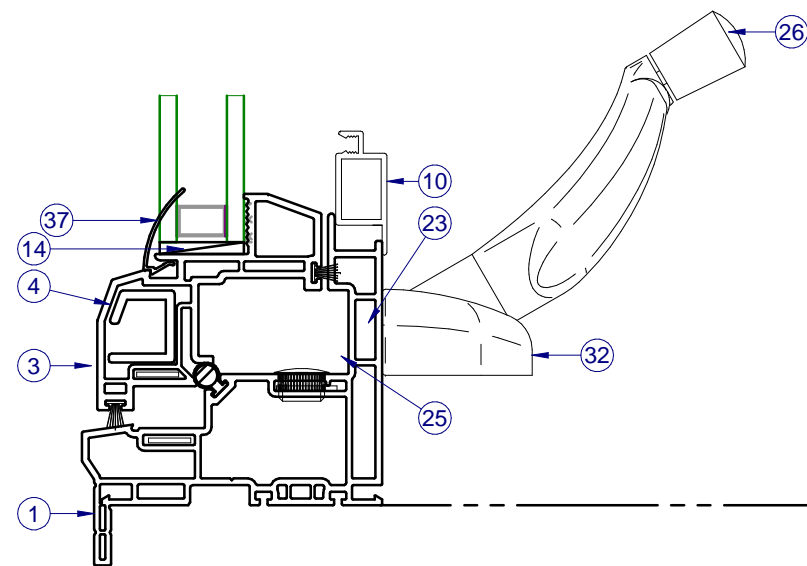

ALTERNATE FIN FRAME

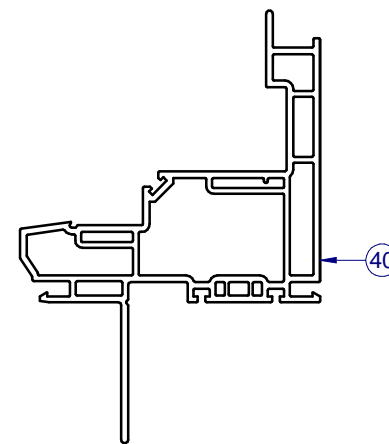

ALTERNATE FIN ONLY FRAME

ITEMS NOT SHOWN FOR CLARITY:
7, 10, 12-14, 16, 18-19, 21, 24, 29-30, 33

PARTS LIST			
ITEM	PART #	DESCRIPTION	MATERIAL
1	H-6235	FR., AWNING., MAIN	PVC
2	P-4050	COIL-ALUMINUM, 5052-H32 (.050 X .437) JB, LEFT	ALUM
3	H-6234	SASH, AWNING, ALL SIDES	PVC
4	S-1505	REINF. AWNING, SASH, ALL SIDES	ALUM
5	H-1592	SCREEN RAIL, SIDE	ALUM
6	H-1593	SCREEN RAIL, TOP/BTM/SIDE	ALUM
7	P-4755	Screen Corner Key W/ Safety Pull Tab	
9	P-3195	SCREEN SPRING, NO HOLE TENSION	SS
10	P-3197	SCREEN CORNER KEY	PLASTIC
11	P-5573	WSTP., BULB, HOLLOW, T-SLOT, .187 X .358	RUBBER
12	P-3228	SCREEN SPLINE, .155 DIA, BLK	
13		SPACER, SEE SHEET 3	
14	P-5612	Setting Block, .12 x 1 x 2	RUBBER
15	P-3305	Wstp., .270 x .187 High Density	
16	P-3565	36" - 18x14 CHARCOAL SCREEN	
17	P-3587	#8 x 1" PH FLAT TEK, ZINC	STEEL
20	P-5588	CAP PLUG, 1/2" HOLE	NYLON
22	P-3940	SNUBBER, SS, PVC	SS
23	P-4004	#8-32 X 1/2" PH PH, MS, SS (ROTO HDWE. LOCK)	SS
24	P-4005	SUPPORT PLATE, LOCK, SS, ROTO HDWE. (Use w/ P-4006)	SS
25	P-4012	SHIM, ROTO OPERATOR, ROTO HDWE. (4.8mm)	
26	P-4503	HANDLE,FOLDING,ROTO OPER., ROTO HDWE	
27	P-4015	HINGE ARM, WASHABILITY, 13", ROTO HARDWARE	
28	P-4018	HINGE TRACK, 13" ROTO HDWE., "A" & "B"	
29	P-4024	GASKET, ROTO OPER., ROTO HDWE., 1/16"	
30	P-4042	GASKET, LOCK	
31	P-4043	STRIKE, MULTI-POINT	NYLON
32	P-4510	ROTO OPERATOR, AWNING "SCISSOR"	
33	P-4045	BRACKET, ROTO OPER., AWNING	
34	P-4049	LOCK, SINGLE POINT (ROTO, HDWE)	
35	P-4521	Screw, 8-32 x 3/4" Trilobe Truss Head	SS
36	P-4641	#8 x 5/8" PH FLAT TEK, #7 HEAD, SS	SS
37	S-6237	GLAZING BEAD	PVC
38		PURFECT GLAZE "H" , SIKAFLEX 552	
39	GLASS	SEE SHEET 2	
40	H-6235	Fin Frame	PVC

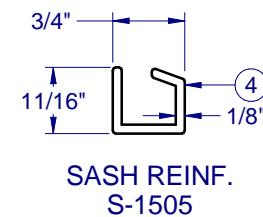
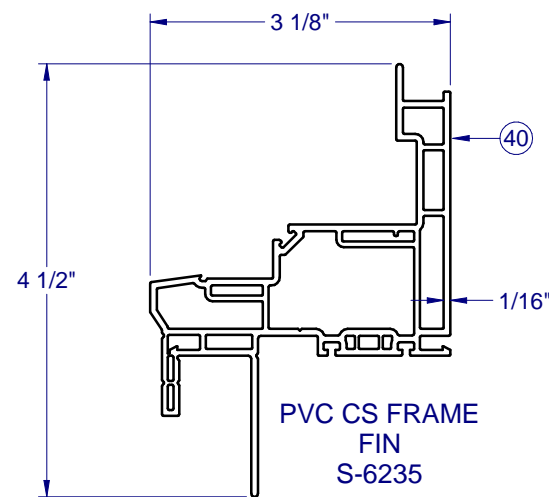
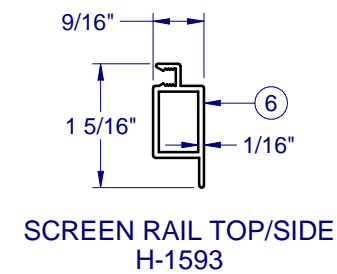
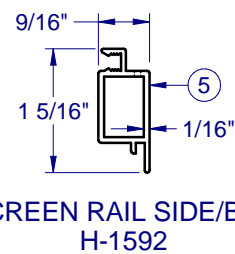
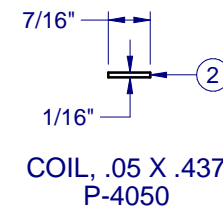
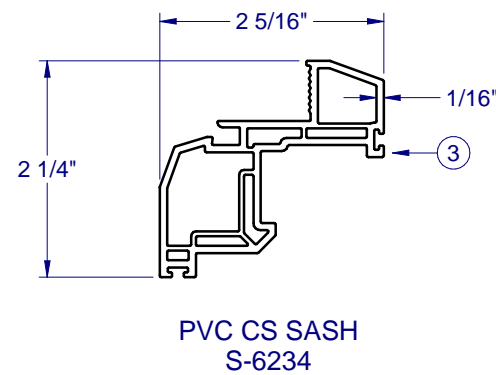
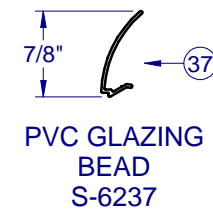
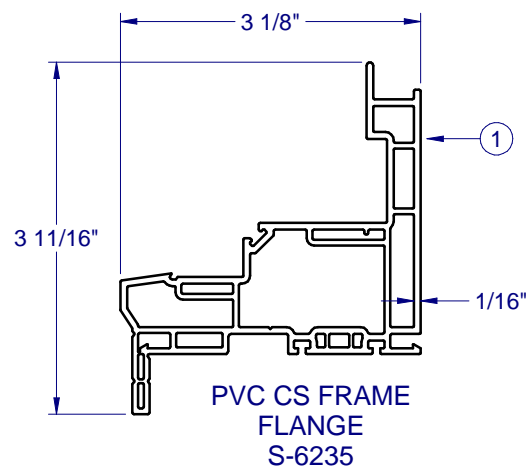

FRAME AND SASH CORNER CONSTRUCTION

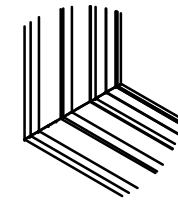

CORNER WELD (ALL SIDES) 1:8



1900 SW 44TH AVE.
OCALA, FLORIDA 34474
WWW.CWS.CC

8450 PVC AWNING NON-IMPACT

PROPRIETARY AND CONFIDENTIAL
THE INFORMATION CONTAINED IN THIS DRAWING IS THE SOLE PROPERTY OF CUSTOM WINDOW SYSTEMS, INC. ANY REPRODUCTION IN PART OR AS A WHOLE WITHOUT THE WRITTEN PERMISSION OF CUSTOM WINDOW SYSTEMS, INC IS PROHIBITED.

FLORIDA APPROVAL NO.:
15032



8/17/2023

LUCAS A. TURNER, P.E.
FL PE # 58201
Turner Engineering & Consulting, Inc.
2428 Old Natchez Trc Trl
Camden, TN 38320
PH. 941-380-1574

SHEET DESCRIPTION:

BOM AND EXTRUSIONS

DRAWN BY: MCS	DATE: 8/10/2023
DWG #: CWS-652	REV.: E
SCALE: 1:2	SHEET 4 OF 6

NOTE: ALL ALUMINUM EXTRUSIONS ARE 6063-T6 UNLESS OTHERWISE NOTED.

**8450 PVC
AWNING
NON-IMPACT**

PROPRIETARY AND CONFIDENTIAL
THE INFORMATION CONTAINED IN
THIS DRAWING IS THE SOLE
PROPERTY OF CUSTOM WINDOW
SYSTEMS, INC. ANY
REPRODUCTION IN PART OR AS A
WHOLE WITHOUT THE WRITTEN
PERMISSION OF CUSTOM WINDOW
SYSTEMS, INC IS PROHIBITED.

FLORIDA APPROVAL NO.:

15032

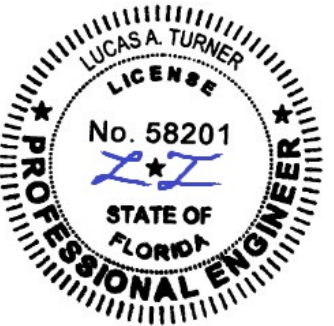

8/17/2023

LUCAS A. TURNER, P.E.
FL PE # 58201
Turner Engineering &
Consulting, Inc.
2428 Old Natchez Trc Trl
Camden, TN 38320
PH. 941-380-1574

SHEET DESCRIPTION:

**ANCHOR SCHEDULE AND
NOTES**

DRAWN BY:	DATE:
MCS	8/10/2023
DWG #:	REV.:
CWS-652	E
SCALE:	SHEET
1:12	5 OF 6

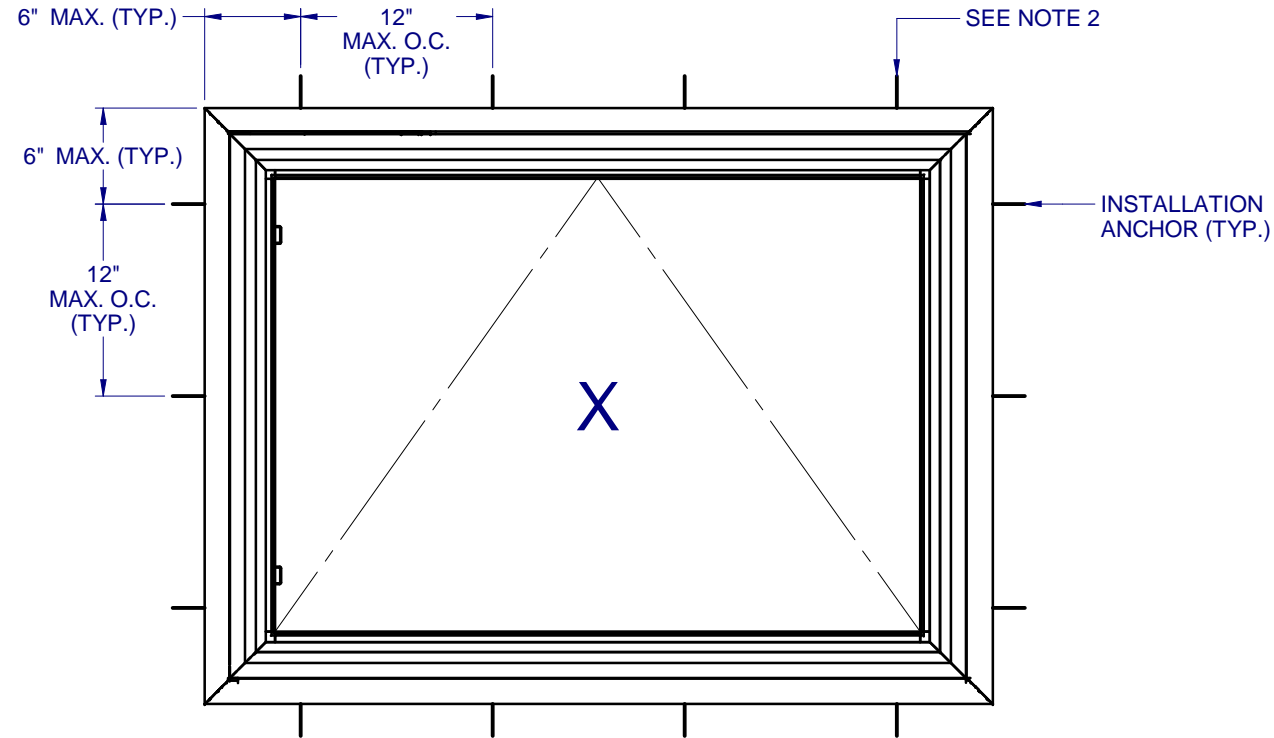

ANCHOR LAYOUT - (FLANGE)

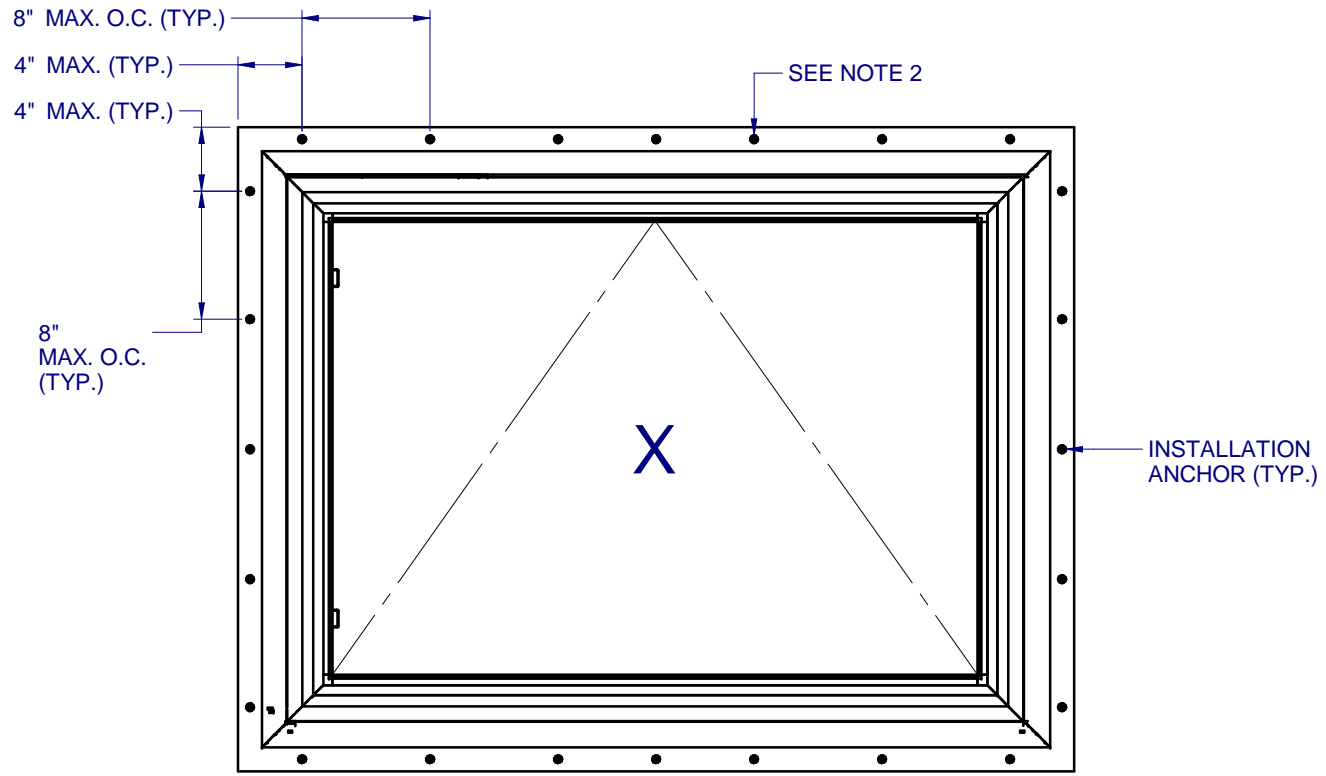

ANCHOR LAYOUT - (FIN)

NOTES:

1. INSTALL ONE ANCHOR AT EACH INSTALLATION LOCATION. SILL ANCHOR SPACING SAME AS HEAD.
2. SHIM AS REQ AT EACH INSTALLATION ANCHOR USING LOAD BEARING SHIMS. MAX. ALLOWABLE SHIM STACK TO BE 1/4". USE SHIMS WHERE SPACE GREATER THAN 1/16" IS PRESENT. LOAD BEARING SHIMS SHALL BE CONSTRUCTED OF HIGH DENSITY PLASTIC OR BETTER. WOOD SHIMS ARE NOT ALLOWED.
3. ANCHOR TYPE, SIZE, SPACING AND EMBEDMENT SHALL BE AS SPECIFIED IN THESE DRAWINGS, SEE TABLE 1, SHEET 6.
4. ALL INSTALLATION ANCHORS MUST BE MADE OF OR PROTECTED WITH A CORROSION RESISTANT MATERIAL OR COATING. DISSIMILAR METALS OR MATERIALS IN CONTACT WITH PRESSURE TREATED WOOD MUST BE PROTECTED TO PREVENT REACTION.
5. INSTALLATION ANCHORS SHALL BE IN ACCORDANCE WITH ANCHOR MANUFACTURER'S INSTALLATION INSTRUCTIONS, AND ANCHORS SHALL NOT BE USED IN SUBSTRATES WITH STRENGTHS LESS THAN THE MINIMUM SPECIFIED IN TABLE 1, SHEET 6.
6. ANCHOR EMBEDMENT TO SUBSTRATE SHALL BE BEYOND WALL DRESSING OR STUCCO. FOR CONCRETE/CMU OPENINGS, EMBEDMENT SHALL BE BEYOND WOOD BUCKS, IF USED, INTO SUBSTRATE - 1X BUCKS ARE OPTIONAL.
7. A MINIMUM CENTER-TO-CENTER SPACING SHALL BE MAINTAINED BETWEEN ALL FASTENERS: 3" FOR MASONRY, 1" FOR WOOD AND METAL.
8. WOOD OR MASONRY OPENINGS, BUCKS AND BUCK FASTENERS SHALL BE PROPERLY DESIGNED BY THE ARCHITECT OR ENGINEER OF RECORD AND INSTALLED TO TRANSFER WIND LOADS TO THE STRUCTURE. SUBSTRATES SHALL MEET THE MINIMUM STRENGTH REQUIREMENTS AS SHOWN IN TABLE1, SHEET 6. CONCRETE AND MASONRY SUBSTRATES MAY NOT BE CRACKED.
9. SEALING AND FLASHING STRATEGIES FOR OVERALL WATER RESISTANCE OF INSTALLATION SHALL BE DONE BY OTHERS FOLLOWING THE CURRENT VERSION OF THE REFERENCE DOCUMENTS:
FMA/AAMA 100(FIN WINDOWS), FMA/AAMA 200(FLANGE WINDOWS), FMA/WDMA 250(BOX WINDOWS), FMA/AAMA/WDMA 300(EXTERIOR DOORS)

8450 PVC AWNING NON-IMPACT

PROPRIETARY AND CONFIDENTIAL
THE INFORMATION CONTAINED IN THIS DRAWING IS THE SOLE PROPERTY OF CUSTOM WINDOW SYSTEMS, INC. ANY REPRODUCTION IN PART OR AS A WHOLE WITHOUT THE WRITTEN PERMISSION OF CUSTOM WINDOW SYSTEMS, INC IS PROHIBITED.

FLORIDA APPROVAL NO.:

15032

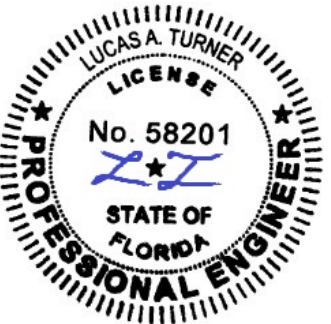

8/17/2023

LUCAS A. TURNER, P.E.
FL PE # 58201
Turner Engineering & Consulting, Inc.
2428 Old Natchez Trc Trl
Camden, TN 38320
PH. 941-380-1574

SHEET DESCRIPTION:

INSTALLATION DETAILS

DRAWN BY:	DATE:
MCS	8/10/2023
DWG #:	REV.:
CWS-652	E
SCALE:	SHEET
1:2	6 OF 6

TYPICAL HEAD ANCHORAGE

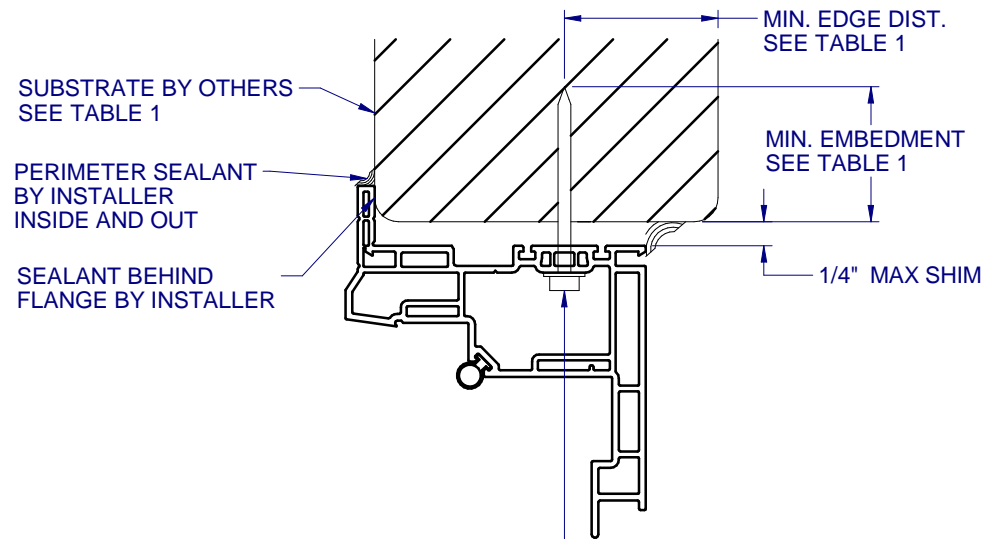

A VERTICAL SECTION
6 TYPICAL SILL ANCHORAGE

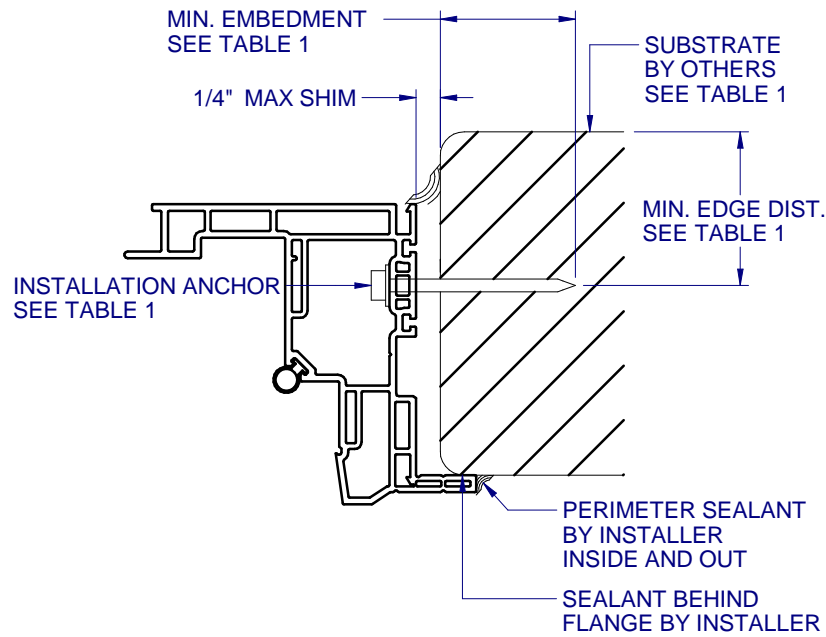

B HORIZONTAL SECTION
6 TYPICAL JAMB ANCHORAGE

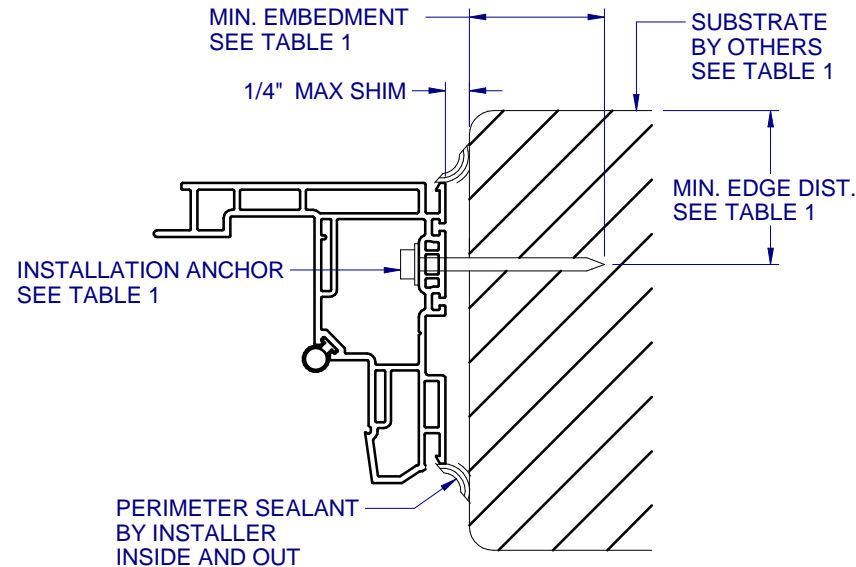

D HORIZONTAL SECTION
6 BOX FRAME INSTALLATION
HEAD AND SILL SIMILAR FOR BOX INSTALLATION

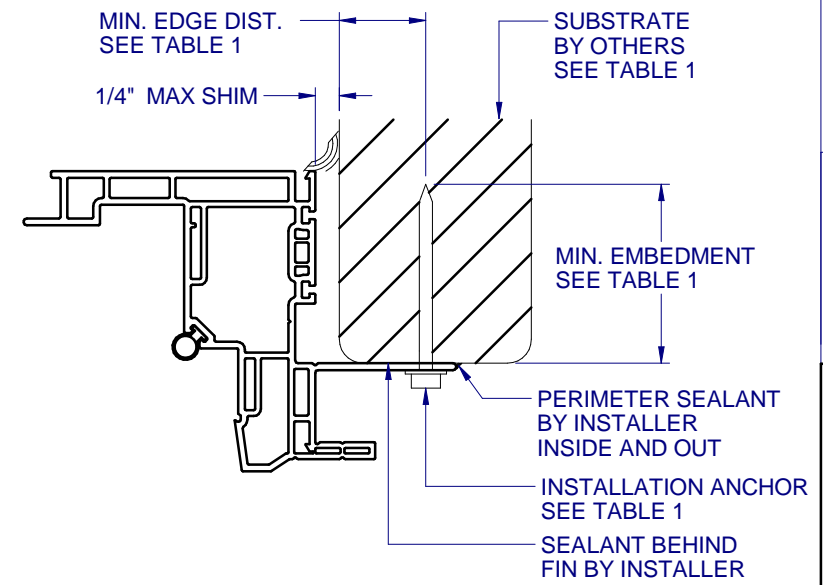

C HORIZONTAL SECTION
6 TYPICAL FIN ANCHORAGE
HEAD AND SILL SIMILAR FOR FIN INSTALLATION

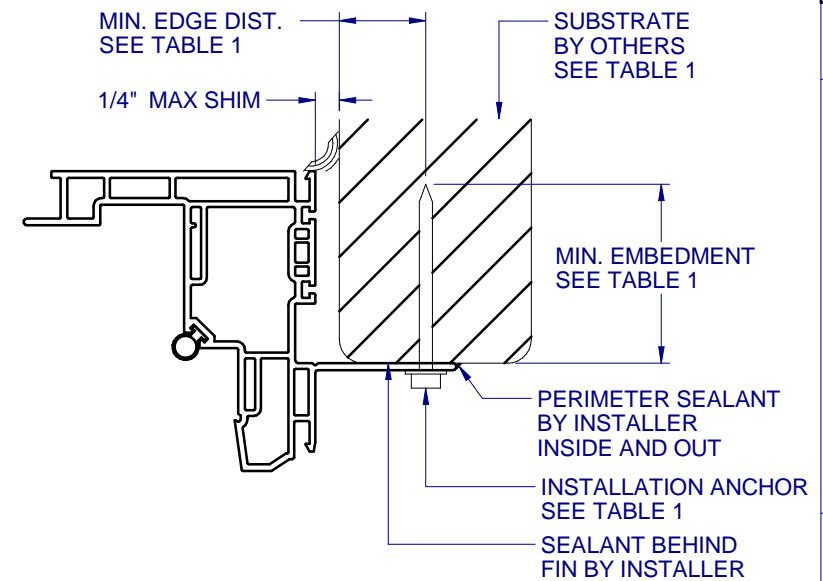

E HORIZONTAL SECTION
6 TYPICAL FIN ANCHORAGE
HEAD AND SILL SIMILAR FOR FIN INSTALLATION

TABLE 1: APPROVED INSTALLATION FASTENERS

FRAME TYPE	SUBSTRATE TYPE	ANCHOR TYPE	MIN. EMBEDMENT	MIN. EDGE DIST.
FLANGE	CONCRETE (2.0 KSI MIN.)	3/16" ITW TAPCON	1"	1-1/8"
FLANGE	HOLLOW OR GROUT-FILLED CMU (117 PCF MIN.)	3/16" ITW TAPCON	1"	2"
FLANGE	CONCRETE (3.05 KSI MIN.)	3/16" DEWALT ULTRACON+	1-3/4"	1"
FLANGE	HOLLOW OR GROUT-FILLED CMU (ASTM C-90)	3/16" DEWALT ULTRACON+	1-1/4"	2-1/2"
FLANGE	2X MIN. SPRUCE-PINE-FIR (G=0.42)	3/16" ITW TAPCON OR DEWALT ULTRACON+	1-3/8"	7/8"
FLANGE	2X MIN. SPRUCE-PINE-FIR (G=0.42)	#10 WOOD SCREW	1-3/8"	7/8"
FLANGE	16 GAUGE (0.060") MIN. STEEL STUD (33 KSI YIELD MIN)	#10-16 HILTI KWIK-FLEX OR ITW TEKS SELF-DRILLING SCREW	FULL THREAD THRU 0.060"	7/16"
FLANGE	1/8" ALUM. (6063-T5 MIN.) OR 1/8" STEEL (33 KSI MIN.)	#10 GRADE 5 SELF-TAPPING / DRILLING SCREW	FULL THREAD THRU 0.125"	7/16"
FIN	2X MIN. SPRUCE-PINE-FIR (G=0.42)	#8 WOOD SCREW	1-1/2"	7/16"

FLANGE REMOVAL NOTE: PARTIALLY OR FULLY REMOVING THE FLANGE, UP TO AND INCLUDING A BOX-FRAME APPLICATION IS ACCEPTABLE PROVIDED:

- MIN. 1/4" FILLET OF CONSTRUCTION-GRADE ADHESIVE CAULK IS APPLIED INSIDE AND OUT, FULL PERIMETER, BY INSTALLER.
- PRODUCT ANCHORAGE IS IN ACCORDANCE WITH REQUIREMENTS AS SHOWN FOR FLANGE WINDOWS.