

Steel Section
 S24C - .017 thick G-40 galvanized steel
 S24/MB24 - .023 thick G-60 galvanized steel
 S20 - .035 thick G-90 galvanized steel with an epoxy primer and baked on polyester finish which is roll-formed with a smooth texture.

Glass Options:
 1/8" Annealed (shown) or Tempered
 5/8" Insulated Annealed or Insulated Tempered
 Max size - 23-5/16" x 6-5/16"
 DLO - 21-1/2" x 5-1/2"

Door Height
 8'-0" High shown
 Other door heights available up to 24'-0" using 20" or 24" high sections

Locks required on doors not electrically operated.
 Single endstiles standard on doors 16'-2" wide and smaller. Double endstiles optional.

Spring Counterbalance
 Spring wire individually calculated to counterbalance door.
 Quantity and size of spring will vary based on door size.

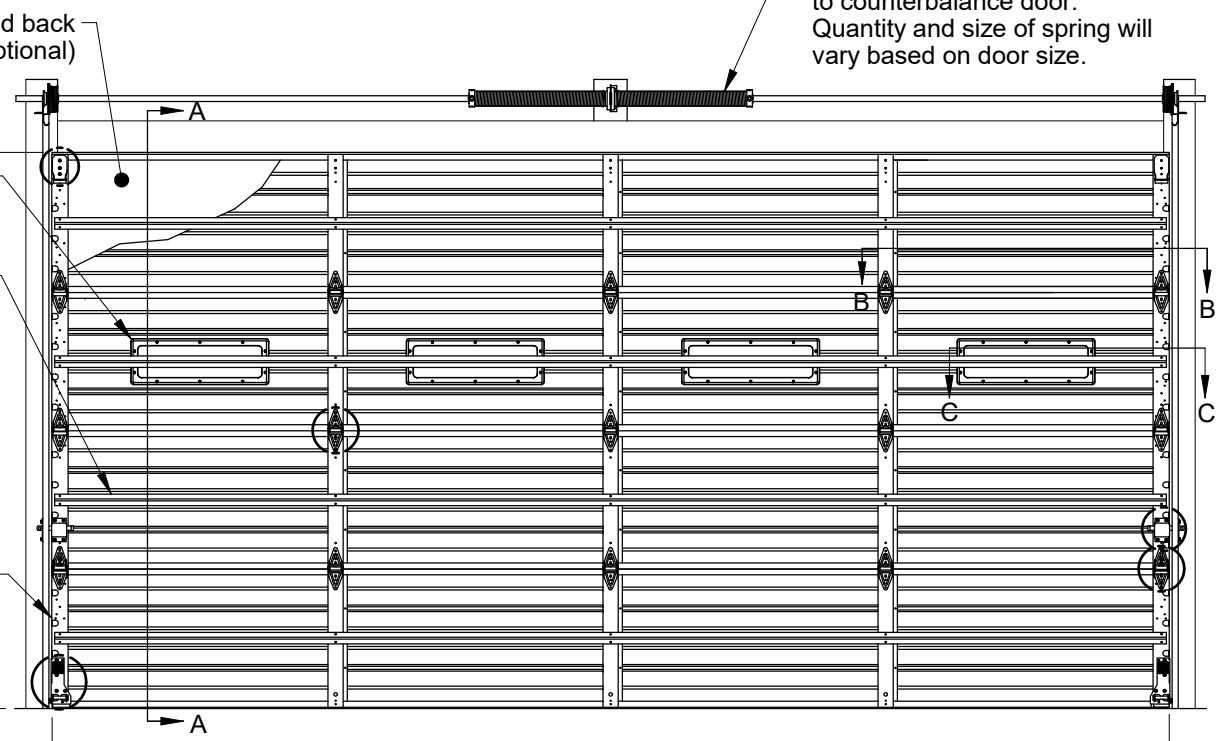

Door Width
 See chart for other door widths (16'-2" shown)
Interior Elevation

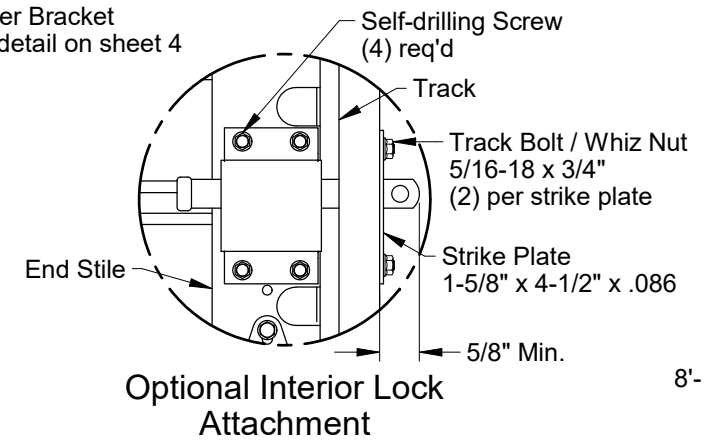
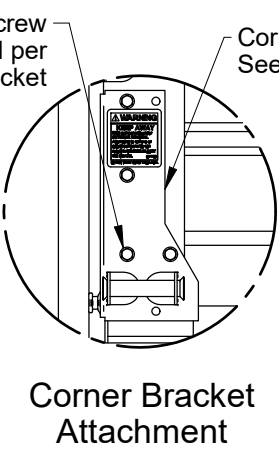
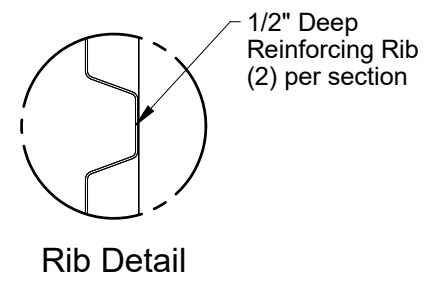

Doors tested per ANSI/DASMA 108 for static air pressure

S24C / S24 / MB24 / S20			
Maximum Door Width	Stiles per Section	Center Hinges per Section	Design Load
8' - 2"	1	1	+ 22.6 - 27.0
9' - 2"	1	1	+ 20.0 - 23.5
10' - 2"	2	2	+ 17.8 - 20.7
11' - 2"	2	2	+ 16.0 - 18.5
12' - 2"	2	2	+ 14.5 - 16.7
13' - 2"	3	3	+ 13.3 - 15.2
14' - 2"	3	3	+ 12.3 - 14.0
15' - 2"	3	3	+ 11.4 - 12.9
16' - 2"	3	3	+ 10.6 - 12.0



Scott A. Brown, P.E. Lic. No. 65940
 Wender Engineering Services, Inc.
 698 Timber Creek Road, Dixon, IL 61021
 FBPE CA Lic. No. 31544
 Structural Adequacy for Wind Load

Rev.	Description	ECO	Date	ECO: 6338.01
E	Concrete and CMU lap requirement was 2.00 on clip angle.	8517.02	09/10/21	
D	Added pre-assembled track, MB24 and updated format.	8517.01	02/18/21	
C	Was 36" on sheet 2. Added CMU Block detail on sheet 4. Updated title block.	7679.01	04/25/19	

Scale: None

Drawn by: G. Wedekind

Checked by: G. Wedekind

Date: 03/12/12

RAYNOR

1101 East River Road
 Dixon, IL 61021

Title: Spec, Wind Load
 SteelForm - S24C, S24, MB24, S20

No. **P-2406**

Sheet 1 of 4

Rev **E**

Jamb Attachment Notes:

1. Maximum Positive Load per Jamb = (8'-2" x 22.6 PSF) / 2 = 93 lbs. per foot.
2. Maximum Negative Load per Jamb = (8'-2" x -27.0 PSF) / 2 = 111 lbs. per foot.
3. Design of the supporting structure shall be the sole responsibility of the building designer and shall be designed for the jamb loads listed in notes 1 and 2.
4. Alternate jamb attachments may be used if approved by a registered Professional Engineer.
5. DASMA Technical Data Sheet TDS-161 may be used for alternate jamb attachments.
6. 3/8" diameter lag screws required 1/4" pilot hole and 1-1/2" minimum required distance.
7. Masonry fasteners by others.

2x6 Attachment to Structure						
Structure Type	Fastener Type	Minimum Embedment	Minimum Edge Distance	Minimum on Center Spacing	Maximum on Center Spacing	Allowable Tension Load
2500 PSI Min. Concrete	1/4" Tapcon+ (Plus) with 1-1/8" OD Washer	2"	2.5"	6"	24"	526
Southern Pine	3/8" x 3" Lag with 1-1/8" OD Washer	1.50"	1.50"	1.50"	24"	655
Spruce Pine Fir	3/8" x 3" LAG with 1-1/8" OD Washer	1.50"	1.50"	1.50"	24"	482

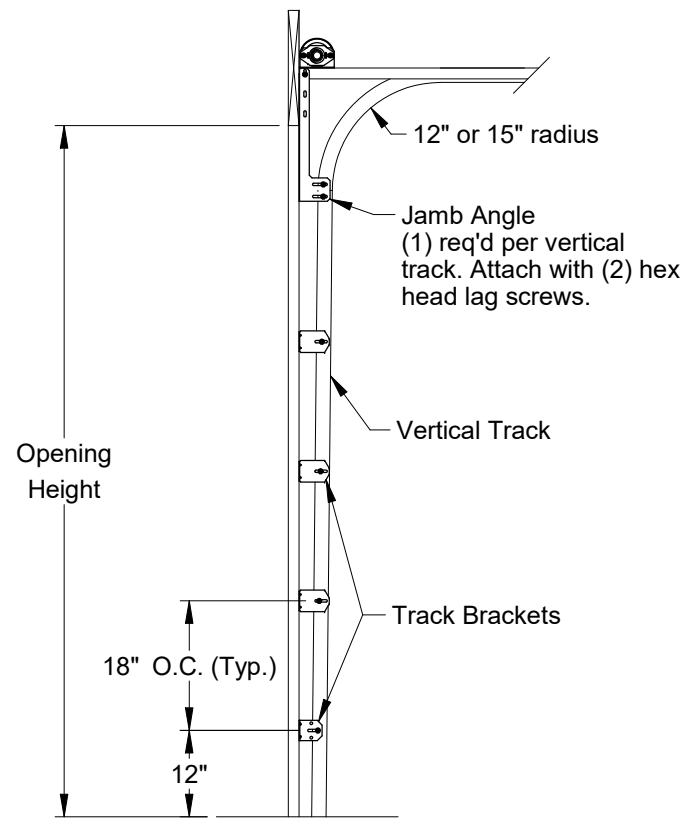
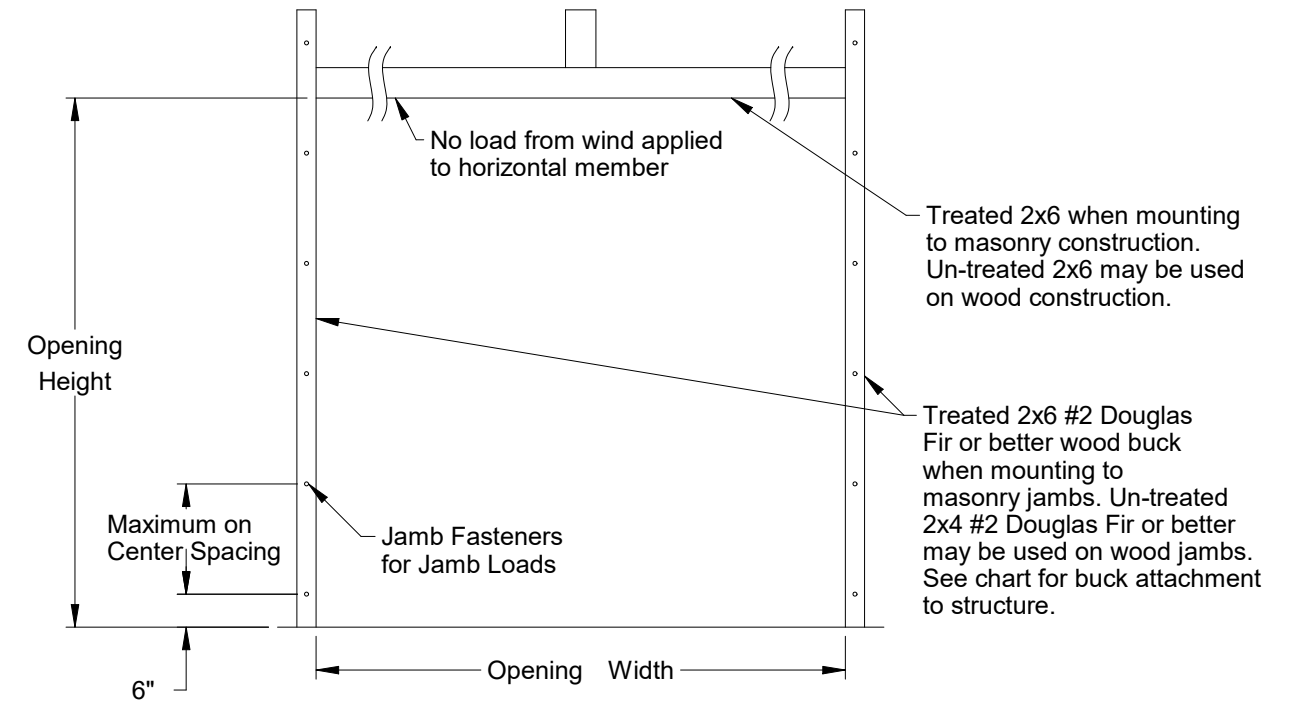

**Typical Track Installation
Bracket Mount
Wood Jamb**

Normal headroom track shown, low headroom, lift clearance and verical lift track available.

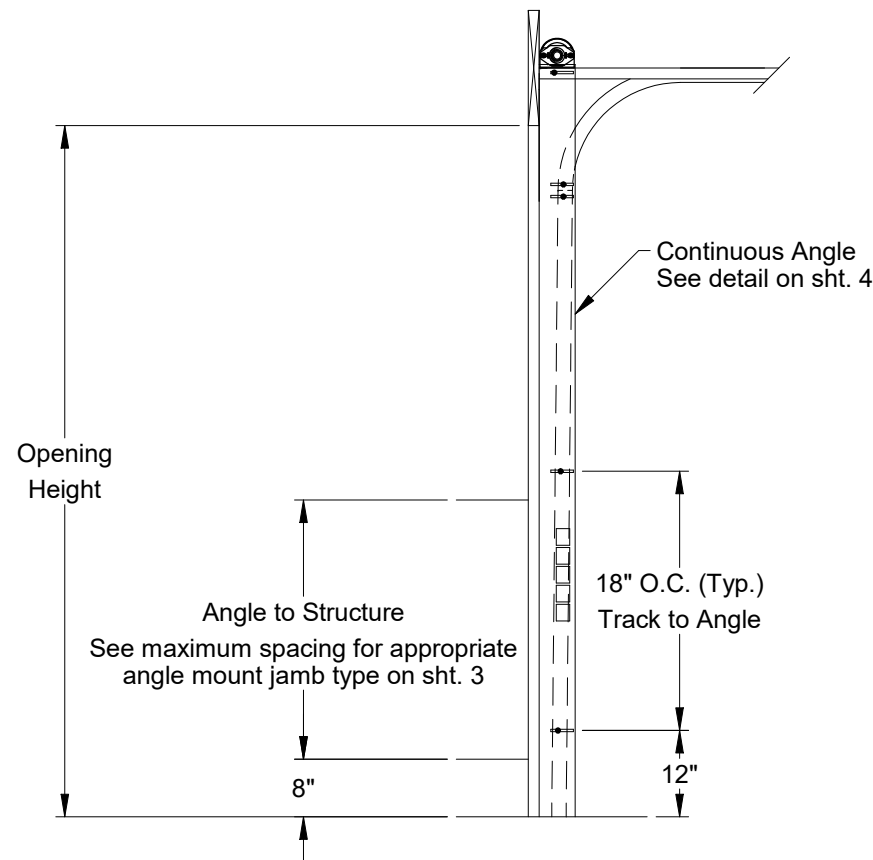

**Typical Track Installation
Angle Mount
Wood, Steel or Concrete Jamb**

Normal headroom track shown, low headroom, lift clearance and verical lift track available.

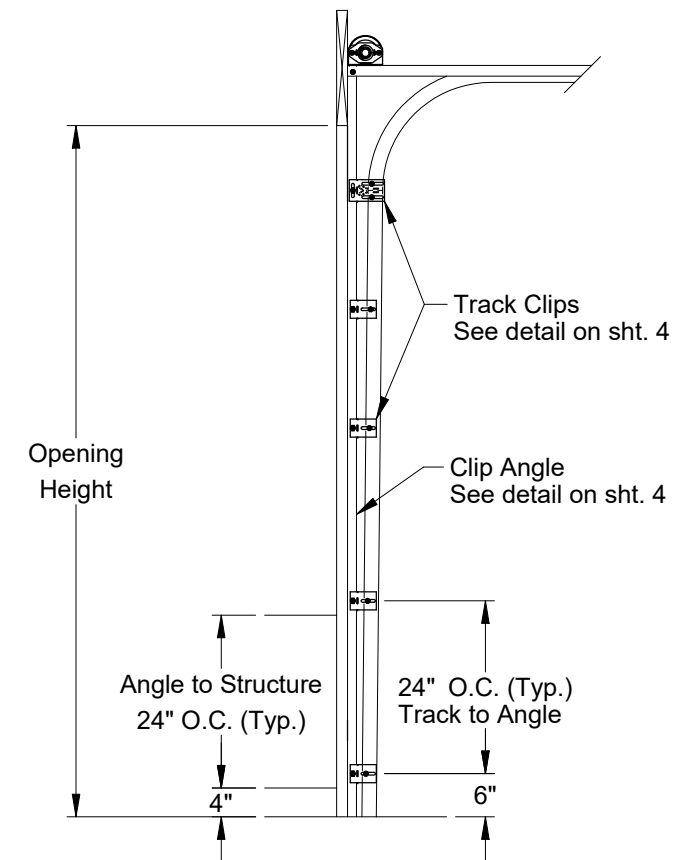

**Typical Track Installation
Pre-Assembled Clip Angle
Wood, Steel or Concrete Jamb**

Normal headroom track shown, lift clearance and verical lift track available.



Scott A. Brown, P.E. Lic. No. 65940
Wendler Engineering Services, Inc.
698 Timber Creek Road, Dixon, IL 61021
FBPE CA Lic. No. 31544
Structural Adequacy for Wind Load

Scale: None	<p>1101 East River Road Dixon, IL. 61021</p>	Title: Spec, Wind Load SteelForm - S24C, S24, MB24, S20	
Drawn by: G. Wedekind		No. P-2406	Sheet 2
Checked by: G. Wedekind			
Date: 03/12/12			
ECO: 6338.01			

Angle Mount					
Jamb Type	Fastener Type	Minimum Embedment (in.)	Minimum Edge Distance (in.)	Maximum on Center Spacing (in.)	Allowable Tension Load (lbs.)
2500 PSI Min. Concrete	3/8" ITW Trubolt	2-1/2"	2-1/2"	36"	893
	1/4" Tapcon+ (Plus) with 1-1/8" OD Washer	2"	1-5/8"	36"	687
	1/4" x 2-5/8" Screw-Bolt+ with 9/16" OD Washer	2-1/2"	1-1/2"	36"	651
Steel	5/16" x 1" SAE J78, Min. AISI 1022 with 5/16" Washer	3/16"	1-1/2"	36"	971
Wood	5/16" x 1-3/4" Lag with 5/16" Washer	1-1/2"	1-1/2"	36"	352
Grout Filled CMU Block	3/8" Simpson Titen HD	2-3/4"	4"	36"	480

Alternate fasteners may be used if approved by a registered Professional Engineer.

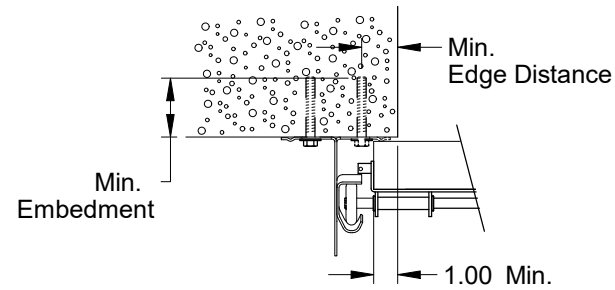

Track Assembly Attachment to 2500 PSI Min. Concrete

2" Angle mount turned-out standard (solid)
2" Angle mount turned-in optional (dashed)
3" Angle mount available

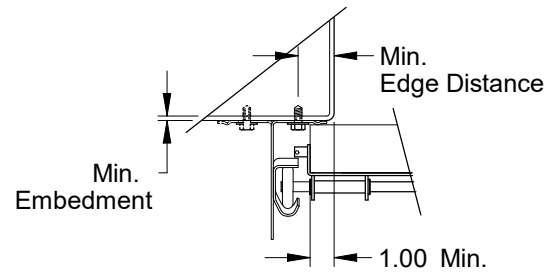

Track Assembly Attachment to 3/16" Min. Steel Jamb

2" Angle mount turned-out standard (solid)
2" Angle mount turned-in optional (dashed)
3" Angle mount available

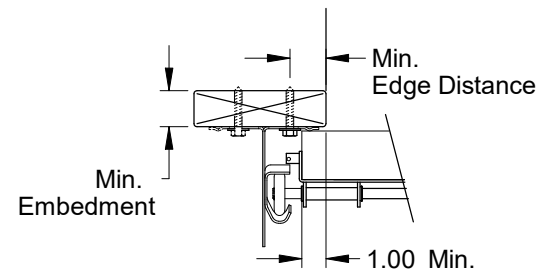

Track Assembly Attachment to Wood Jamb

2" Angle mount turned-out standard (solid)
2" Angle mount turned-in optional (dashed)
3" Angle mount available

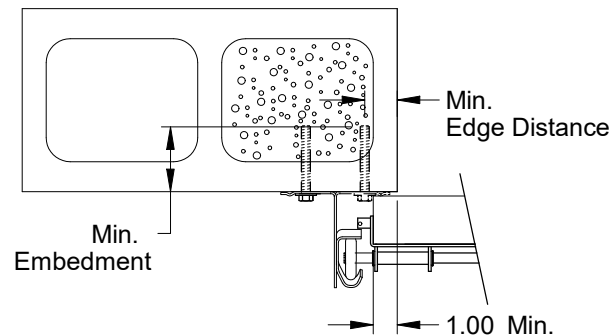

Track Assembly Attachment to Grout Filled CMU Block

2" Angle mount turned-out standard (solid)
2" Angle mount turned-in optional (dashed)
3" Angle mount available

Pre-Assembled Clip Angle					
Jamb Type	Fastener Type	Minimum Embedment (in.)	Minimum Edge Distance (in.)	Maximum on Center Spacing (in.)	Allowable Tension Load (Lbs.)
2500 PSI Min. Concrete	3/8" ITW Trubolt	2-1/2"	2-1/2"	24"	893
	1/4" Tapcon+ (Plus) with 1-1/8" OD Washer	2"	1-5/8"	24"	687
	1/4" x 2-5/8" Screw-Bolt+ with 9/16" OD Washer	2-1/2"	1-1/2"	24"	651
Steel	5/16" x 1" SAE J78, Min. AISI 1022 with 5/16" Washer	3/16"	1-1/2"	24"	971
Wood	5/16" x 1-3/4" Lag with 5/16" Washer	1-1/2"	1-1/2"	24"	352
Grout Filled CMU Block	3/8" Simpson Titen HD	2-3/4"	4"	24"	480

Alternate fasteners may be used if approved by a registered Professional Engineer.

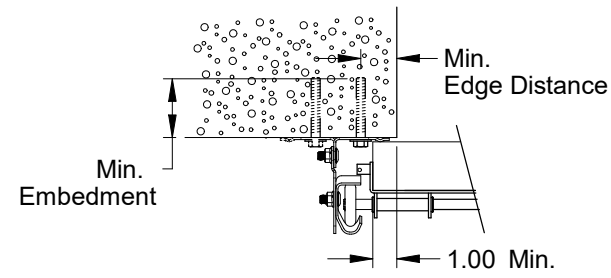

Pre-Assembled Track Assembly Attachment to 2500 PSI Min. Concrete

2" Clip angle turned-in standard (solid)
2" Clip angle turned-out optional (dashed)
3" Clip angle available

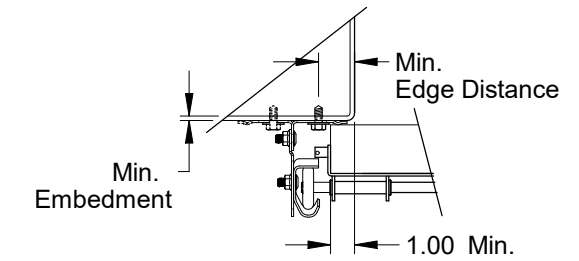

Pre-Assembled Track Assembly Attachment to 3/16" Min. Steel Jamb

2" Clip angle turned-in standard (solid)
2" Clip angle turned-out optional (dashed)
3" Clip angle available

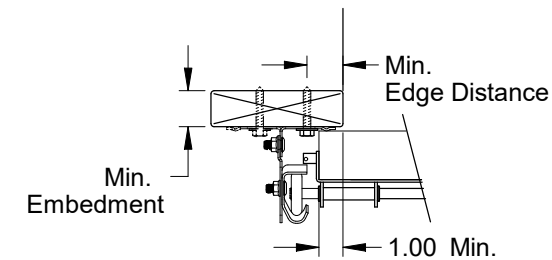

Pre-Assembled Track Assembly Attachment to Wood Jamb

2" Clip angle turned-in standard (solid)
2" Clip angle turned-out optional (dashed)
3" Clip angle available

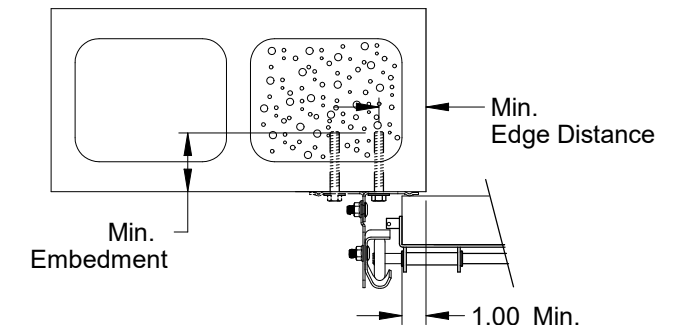

Pre-Assembled Track Assembly Attachment to Grout Filled CMU Block

2" Clip angle turned-in standard (solid)
2" Clip angle turned-out optional (dashed)
3" Clip angle available



Scott A. Brown, P.E. Lic. No. 65940
Wendler Engineering Services, Inc.
698 Timber Creek Road, Dixon, IL 61021
FBPE CA Lic. No. 31544
Structural Adequacy for Wind Load

Scale: None	 1101 East River Road Dixon, IL. 61021	Title: Spec, Wind Load SteelForm - S24C, S24, MB24, S20	
Drawn by: G. Wedekind		No. P-2406	Sheet 3
Checked by: G. Wedekind			
Date: 03/12/12 ECO: 6338.01			

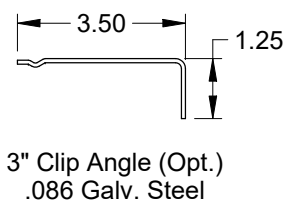
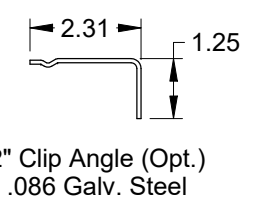
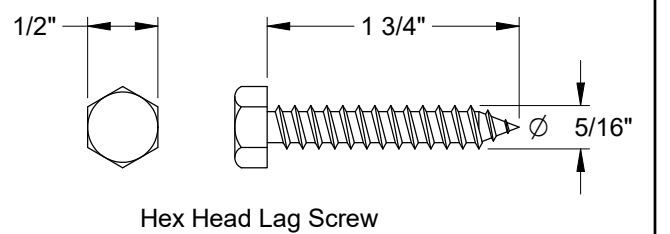
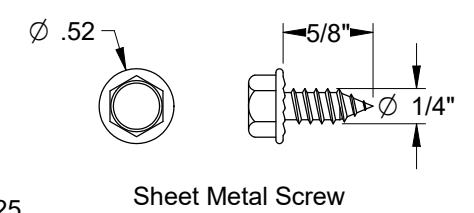
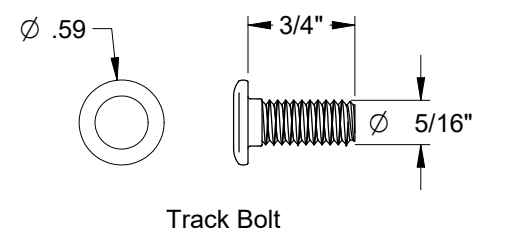
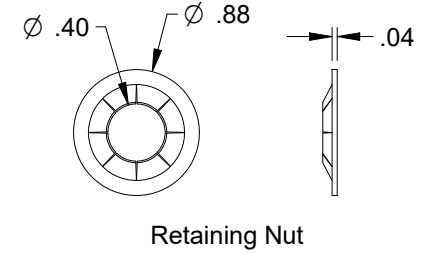
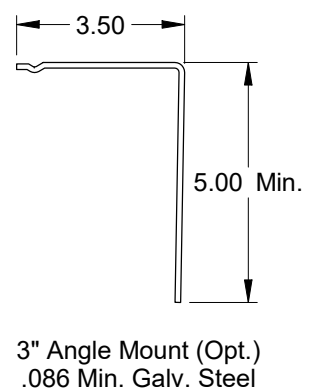
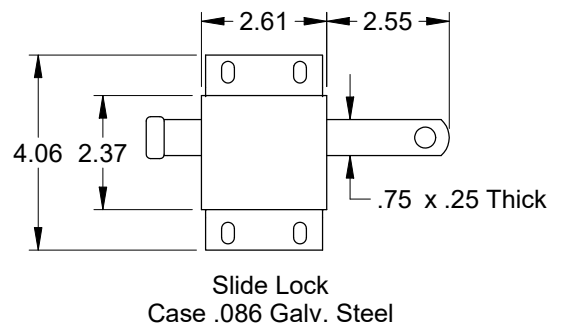
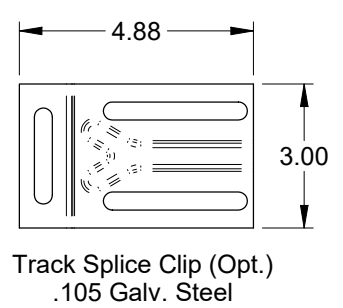
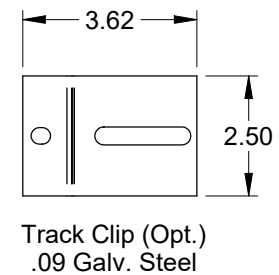
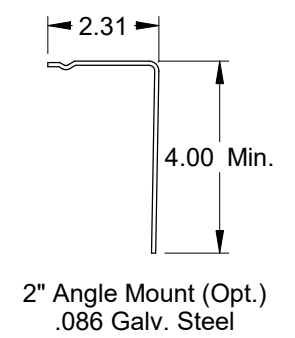
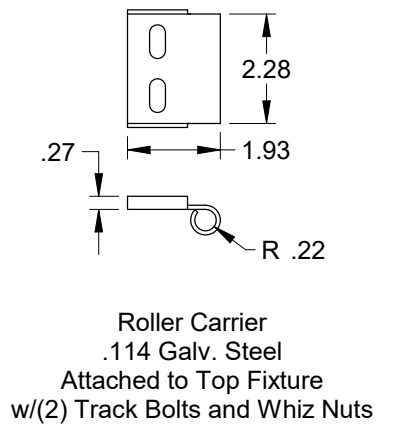
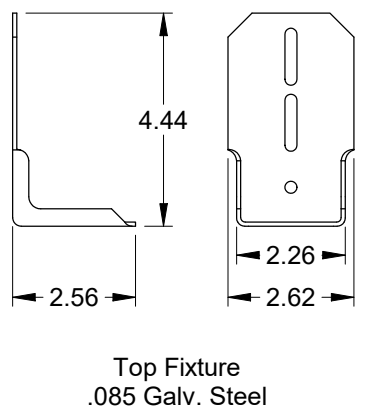
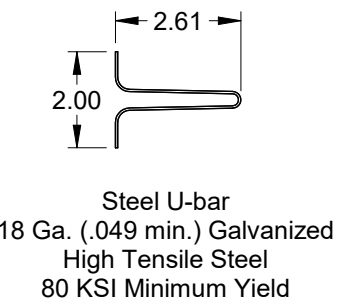
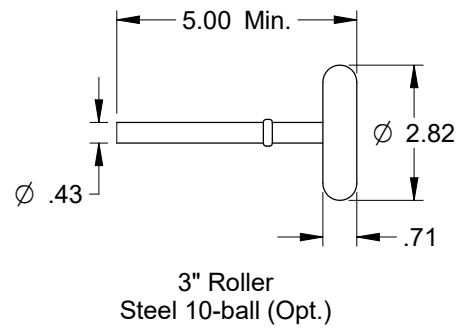
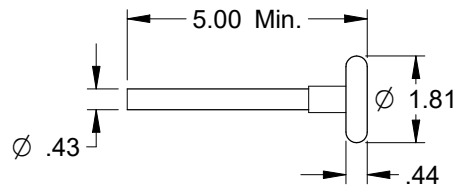
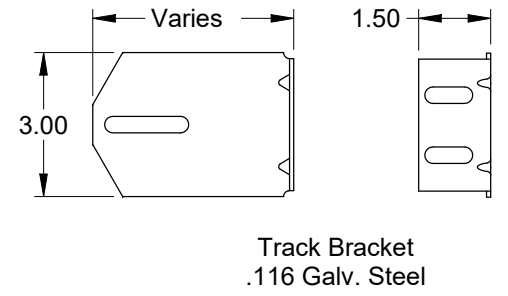
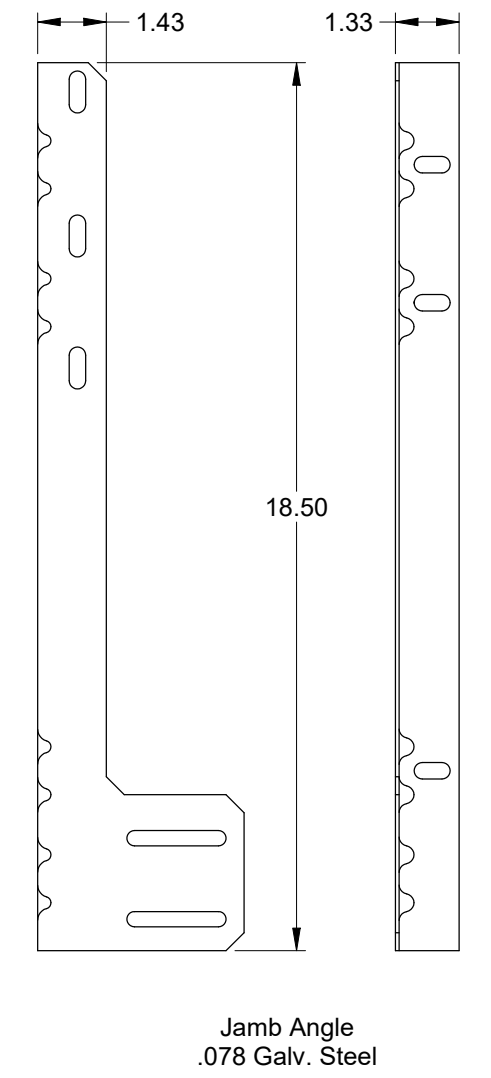
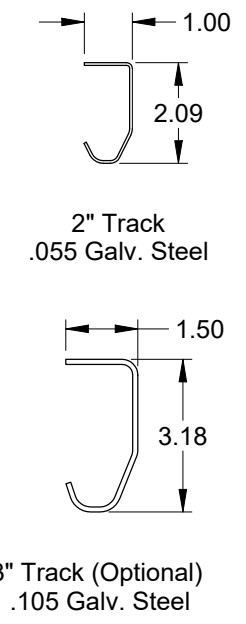
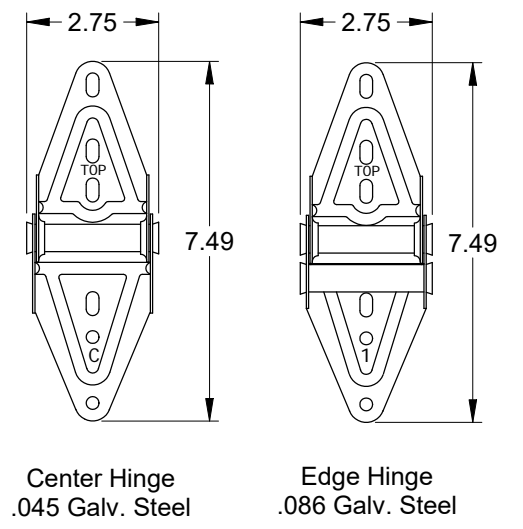
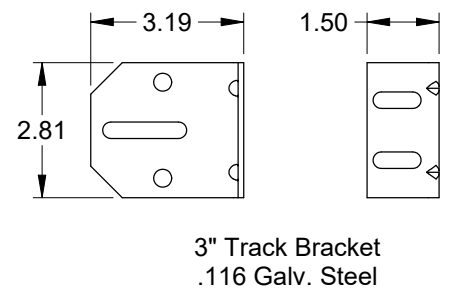
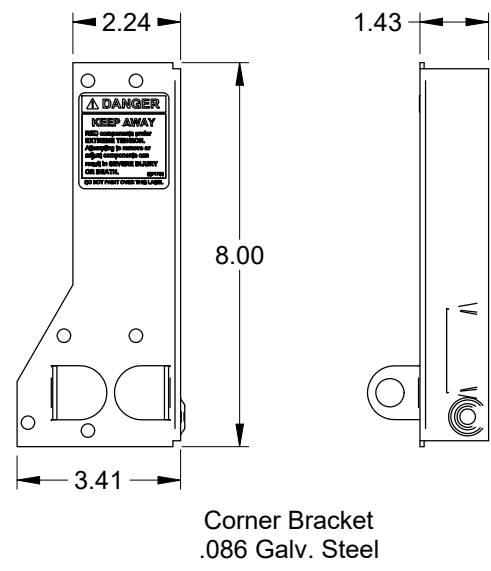

Scott A. Brown, P.E. Lic. No. 65940
Wendler Engineering Services, Inc.
698 Timber Creek Road, Dixon, IL 61021
FBPE CA Lic. No. 31544
Structural Adequacy for Wind Load

Printed copies of this document are not considered signed and sealed and the SHA authentication code must be verified on any electronic copies.

Scale: None
Drawn by: G. Wedekind
Checked by: G. Wedekind
Date: 03/12/12
ECO: 6338.01



Title: Spec, Wind Load SteelForm - S24C, S24, MB24, S20		
No. P-2406	Sheet 4	Rev E