

JELD-WEN, inc.

CUSTOM COLLECTION ALUMINUM CLAD DOUBLE HUNG WINDOW

INSTALLATION NOTES:

- ONE (1) INSTALLATION ANCHOR IS REQUIRED AT EACH ANCHOR LOCATION SHOWN.
- THE NUMBER OF INSTALLATION ANCHORS DEPICTED IS THE MINIMUM NUMBER OF ANCHORS TO BE USED FOR PRODUCT INSTALLATION.
- INSTALL INDIVIDUAL INSTALLATION ANCHORS WITHIN A TOLERANCE OF ±1/2 INCH OF THE DEPICTED LOCATION IN THE ANCHOR LAYOUT DETAIL (I.E., WITHOUT CONSIDERATION OF TOLERANCES). TOLERANCES ARE NOT CUMULATIVE FROM ONE INSTALLATION ANCHOR TO THE NEXT.
- SHIM AS REQUIRED AT EACH ANCHOR LOCATION WHERE SPACE BETWEEN PRODUCT AND STRUCTURE IS 1/16 INCH OR GREATER. MAXIMUM ALLOWABLE SHIM STACK IS NOT TO EXCEED 1/4". ALL SHIMS ARE TO BE LOAD BEARING, HIGH DENSITY PLASTIC OR BETTER.
- FOR INSTALLATION INTO WOOD FRAMING USE #10 WOOD SCREWS OF SUFFICIENT LENGTH TO ACHIEVE 1-1/2 INCH MINIMUM EMBEDMENT INTO WOOD SUBSTRATE.
- FOR INSTALLATION THROUGH 1X BUCK TO CONCRETE/MASONRY, OR DIRECTLY INTO CONCRETE/MASONRY, USE 3/16 INCH DIAMETER ITW TAPCONS OF SUFFICIENT LENGTH TO ACHIEVE 1-1/4 INCH MINIMUM EMBEDMENT.
- MINIMUM EMBEDMENT AND EDGE DISTANCE EXCLUDE WALL FINISHES, INCLUDING BUT NOT LIMITED TO STUCCO, FOAM, BRICK VENEER, AND SIDING.
- INSTALLATION ANCHORS, ALUMINUM FRAMING, AND ASSOCIATED HARDWARE MUST BE MADE OF CORROSION RESISTANT MATERIAL OR HAVE A CORROSION RESISTANT COATING IN ACCORDANCE WITH CURRENT FBC PROTECTION STANDARDS.
- FOR HOLLOW OR GROUT FILLED BLOCK, DO NOT INSTALL INSTALLATION ANCHORS INTO MORTAR JOINTS. EDGE DISTANCE IS MEASURED FROM FREE EDGE OF BLOCK OR EDGE OF MORTAR JOINT INTO FACE SHELL OF BLOCK.
- INSTALLATION ANCHORS SHALL BE INSTALLED IN ACCORDANCE WITH ANCHOR MANUFACTURER'S INSTALLATION INSTRUCTIONS, AND ANCHORS SHALL NOT BE USED IN SUBSTRATES WITH STRENGTHS LESS THAN THE MINIMUM STRENGTH SPECIFIED BY THE ANCHOR MANUFACTURER.
- INSTALLATION ANCHOR CAPACITIES FOR PRODUCTS HEREIN ARE BASED ON SUBSTRATE MATERIALS WITH THE FOLLOWING PROPERTIES:
 - WOOD - MINIMUM SPECIFIC GRAVITY OF 0.55.
 - CONCRETE - MINIMUM COMPRESSIVE STRENGTH OF 3152 PSI.
 - MASONRY - STRENGTH CONFORMANCE TO ASTM C-90, (OR GREATER). MINIMUM COMPRESSIVE STRENGTH OF 2000 PSI.

GENERAL NOTES:

- THE PRODUCT SHOWN HEREIN IS DESIGNED AND MANUFACTURED TO COMPLY WITH THE CURRENT FLORIDA BUILDING CODE (FBC), INCLUDING HVHZ AND HAS BEEN EVALUATED ACCORDING TO THE FOLLOWING:
 - TAS 201-94
 - TAS 202-94
 - TAS 203-94
- ADEQUACY OF THE EXISTING STRUCTURAL CONCRETE/MASONRY AND 2X FRAMING AS A MAIN WIND FORCE RESISTING SYSTEM CAPABLE OF WITHSTANDING AND TRANSFERRING APPLIED PRODUCT LOADS TO THE FOUNDATION IS THE RESPONSIBILITY OF THE ENGINEER OR ARCHITECT OF RECORD FOR THE PROJECT OF INSTALLATION.
- 1X AND 2X BUCKS (WHEN USED) SHALL BE DESIGNED AND ANCHORED TO PROPERLY TRANSFER ALL LOADS TO THE STRUCTURE. BUCK DESIGN AND INSTALLATION IS THE RESPONSIBILITY OF THE ENGINEER OR ARCHITECT OF RECORD FOR THE PROJECT OF INSTALLATION.
- THE INSTALLATION DETAILS DESCRIBED HEREIN ARE GENERIC AND MAY NOT REFLECT ACTUAL CONDITIONS FOR A SPECIFIC SITE. IF SITE CONDITIONS CAUSE INSTALLATION TO DEVIATE FROM THE REQUIREMENTS DETAILED HEREIN, A LICENSED ENGINEER OR ARCHITECT SHALL PREPARE SITE SPECIFIC DOCUMENTS FOR USE WITH THIS DOCUMENT IN NON-HVHZ AREAS AND TO BE REVIEWED BY A.H.J (AUTHORITY HAVING JURISDICTION).
- DEVIATION FROM APPROVAL WITHIN THE HVHZ REQUIRES ONE-TIME APPROVAL FROM MIAMI-DADE COUNTY (PERA).
- APPROVED IMPACT PROTECTIVE SYSTEM **IS NOT REQUIRED** ON THIS PRODUCT IN AREAS REQUIRING IMPACT RESISTANCE.
- WINDOW FRAME MATERIAL: WOOD AURALAST
CLADDING MATERIAL: ALUMINUM 6063-T5
- IN ACCORDANCE WITH CURRENT FBC, DISSIMILAR METALS INCLUDING FASTENERS THAT MAY COME INTO CONTACT WITH ALUMINUM UNIT FRAME SHALL BE PROTECTED AS DEFINED IN SEC 2003.
- IN ACCORDANCE WITH CURRENT FBC, SECTION 2411 WOOD COMPONENTS SHALL HAVE BEEN PRESERVATIVE TREATED OR SHALL BE OF A DURABLE SPECIES AS DEFINED IN SECTION 2326.
- GLASS MEETS THE REQUIREMENTS OF ASTM E 1300-04 GLASS CHARTS. SEE SHEET 3 FOR GLAZING DETAILS.

TABLE OF CONTENTS		
SHEET	REVISION	SHEET DESCRIPTION
1	-	INSTALLATION & GENERAL NOTES
2	-	ELEVATIONS & ANCHOR LAYOUT
3	-	DESIGN SCHEDULE & GLAZING DETAILS
4	-	ASSEMBLY SECTIONS
5	-	NAIL FIN INSTALLATION DETAILS
6	-	THROUGH JAMB INSTALLATION DETAILS
7	-	STRAP INSTALLATION DETAILS
8	-	COMPONENTS & BILL OF MATERIALS
9	-	COMPONENTS & BILL OF MATERIALS

MAXIMUM UNIT DIMENSIONS: 37-3/8" X 76"		
GLAZE TYPE	DESIGN PRESSURE	MISSILE IMPACT RATING
A & B	+55.0 / -75.0 PSF	LARGE AND SMALL MISSILE IMPACT RATED
C & D	+50.0 / -60.0 PSF	LARGE AND SMALL MISSILE IMPACT RATED

JELD-WEN

3737 Lakeport Blvd
Klamath Falls, OR, 97601
Phone: (541) 882-3451

DATE: 05/17/2012

SCALE: NTS

TITLE:

Custom Collection Aluminum Clad Double Hung Window
Installation & General Notes

PROJECT ENGINEER:

DRAWN BY: D. Vezo

CHECKED BY:

APPROVED BY:

PART/PROJECT No.:

IDENTIFIER No. N/A

CAD DWG. No.: JW030

PLANT NAME AND LOCATION:
Bend, Oregon

REV: 01

SHEET 1 OF 9



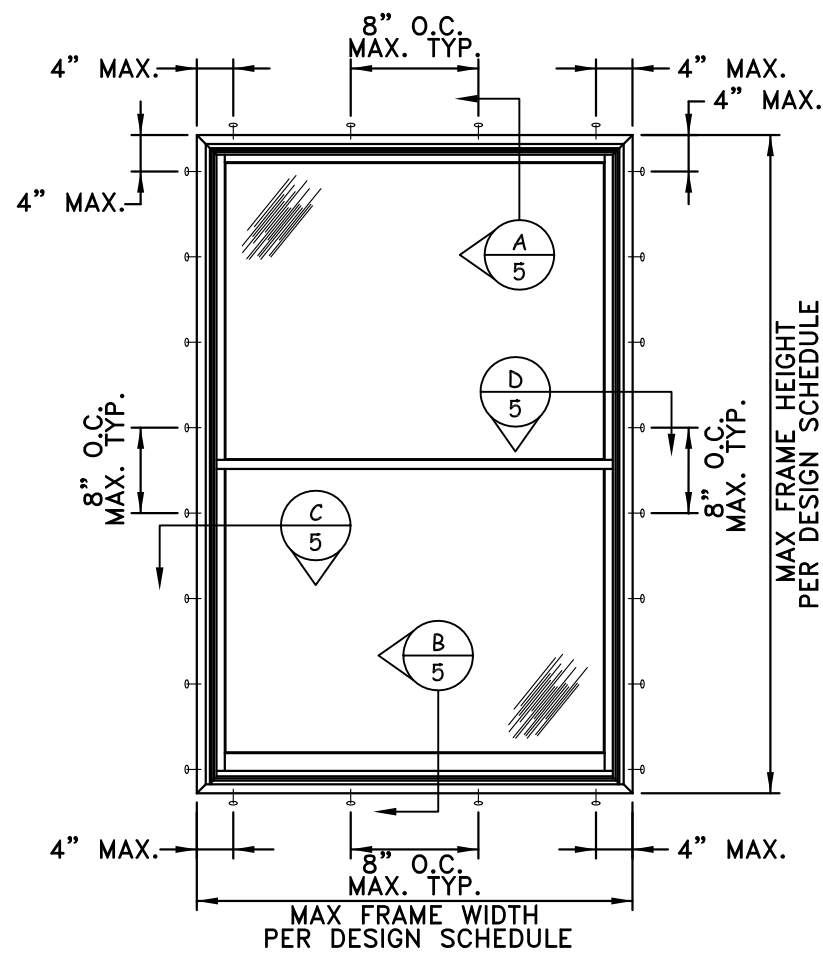

1 ANCHOR ELEVATION FOR
INSTALLATION WITH NAIL FIN
N.T.S. EXTERIOR ELEV

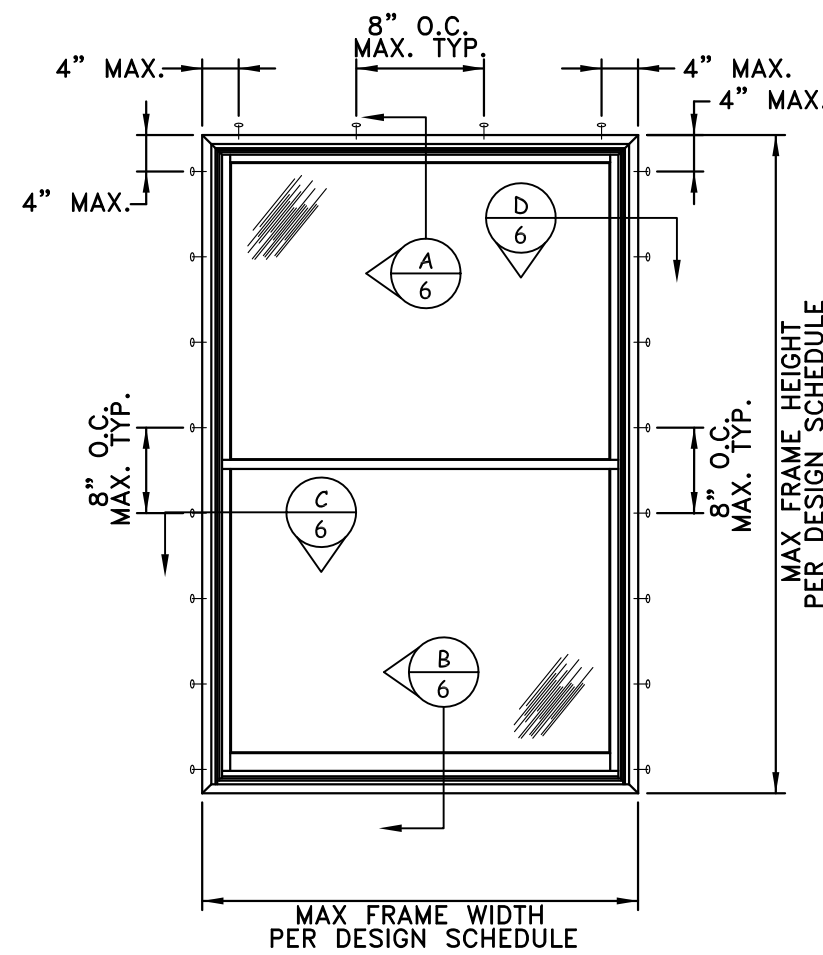

2 ANCHOR ELEVATION FOR
INSTALLATION THROUGH FRAME
N.T.S. EXTERIOR ELEV

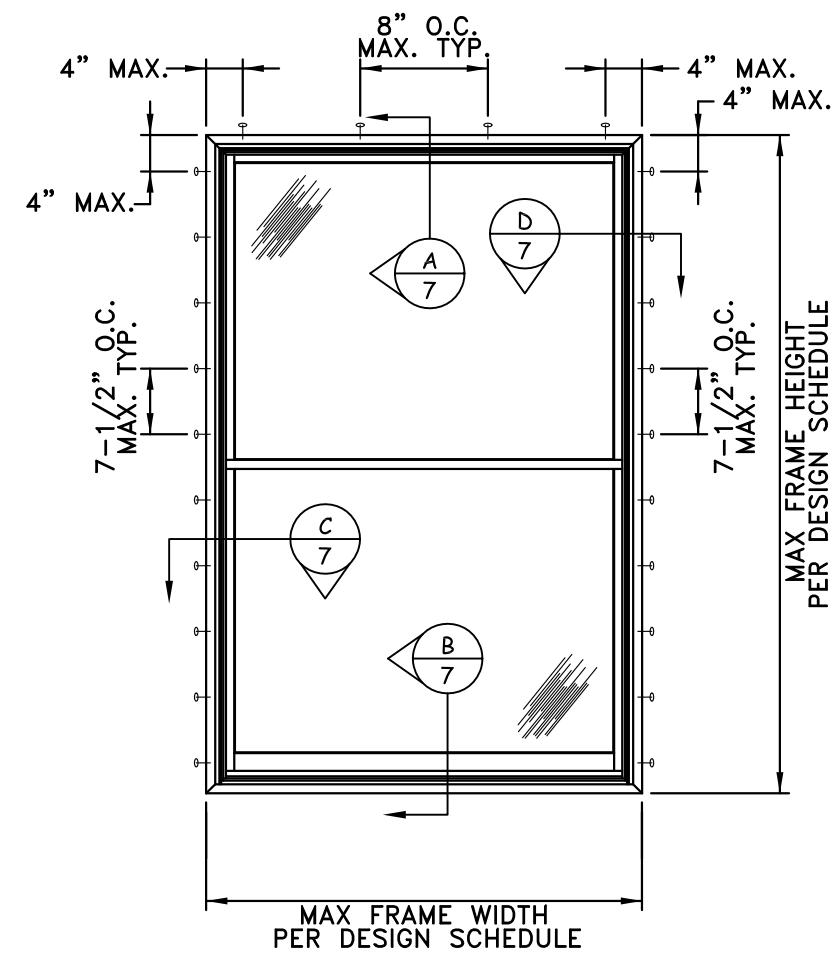

3 ANCHOR ELEVATION FOR
INSTALLATION WITH STRAP
N.T.S. EXTERIOR ELEV

NOTE:
NO ANCHORS ARE USED AT THE SILL FOR INSTALLATION THROUGH THE FRAME OR USING STRAPS.

ANCHOR NOTES

1. SEE ANCHOR ELEVATIONS FOR ANCHOR LOCATIONS AND/OR SPACING.
2. ANCHORS SHALL BE INSTALLED IN ACCORDANCE WITH MANUFACTURERS' RECOMMENDATIONS.
3. TAPCONS MANUFACTURED BY ITW.
4. ENSURE MINIMUM 2-1/2" EDGE DISTANCE FOR ALL ANCHORS INTO CONCRETE AND MASONRY BLOCK.
5. WHERE ANCHORS FASTEN TO NARROW FACE OF STUD FRAMING, ANCHOR SHALL BE LOCATED IN CENTER OF NOMINAL 2X (MIN) WOOD STUD (i.e. 3/4" EDGE DISTANCE IS ACCEPTABLE FOR ANCHORS TO WOOD FRAMING).
6. WOOD HOST STRUCTURE SHALL BE SOUTHERN PINE (SG=0.55) OR GREATER DENSITY.
7. MINIMUM EMBEDMENT SHALL BE AS NOTED IN ANCHOR SCHEDULE. MINIMUM EMBEDMENT AND EDGE DISTANCE EXCLUDE STUCCO, FOAM, BRICK, AND OTHER WALL FINISHES.
8. ANCHOR SCHEDULE APPLIES TO ALL PRODUCTS CERTIFIED HEREIN.
9. WHERE EXISTING STRUCTURE IS WOOD FRAMING, EXISTING CONDITIONS MAY VARY. FIELD VERIFY THAT FASTENERS ARE INTO ADEQUATE WOOD FRAMING MEMBERS, NOT INTO PLYWOOD.
10. WOOD BUCKS (BY OTHERS) SHALL BE ANCHORED PROPERLY TO TRANSFER LOADS TO THE EXISTING STRUCTURE.

ANCHOR SCHEDULE

TO MASONRY BLOCK OR 3192 PSI MIN CONCRETE HOST STRUCTURE

3/16" TAPCONS (ITW) THRU 1X OR DIRECTLY INTO MASONRY/CONCRETE WITH 1-1/4" MIN. EMBEDMENT & 2-1/2" MIN. EDGE DISTANCE.

TO WOOD BUCK OR HOST STRUCTURE (MIN S.G. = 0.55)

#10 WOOD SCREWS WITH 1-1/2" MIN. EMBEDMENT & 1" MIN. EDGE DISTANCE.

3737 Lakeport Blvd
Klamath Falls, OR. 97601
Phone: (541) 882-3451

JELD-WEN

Custom Collection Aluminum Clad Double Hung Window
Elevations and Anchor Layouts

DATE: 05/17/2012
SCALE: NTS
TITLE:

PROJECT ENGINEER: --
DRAWN BY: D. Vezo
CHECKED BY: --
APPROVED BY: --
PART/PROJECT No.: --
IDENTIFIER No. N/A

CAD DWG. No.: JW030
REV: 01
SHEET 2 OF 9

PLANT NAME AND LOCATION:
Bend, Oregon

DESIGN SCHEDULE

FRAME HEIGHT	SASH HEIGHT	DLO HEIGHT	GLAZING TYPE	21 3/8"	25 3/8"	29 3/8"	31 3/8"	33 3/8"	35 3/8"	37 3/8"	FRAME WIDTH
				18 3/8"	22 3/8"	26 3/8"	28 3/8"	30 3/8"	32 3/8"	34 3/8"	SASH WIDTH
				15 1/2"	19 1/2"	23 1/2"	25 1/2"	27 1/2"	29 1/2"	31 1/2"	DLO WIDTH
32"	16"	12"	A, B	+55/-75	+55/-75	+55/-75	+55/-75	+55/-75	+55/-75	+55/-75	MAX. ALLOWABLE DESIGN PRESSURE (PSF)
			C, D	+50/-60	+50/-60	+50/-60	+50/-60	+50/-60	+50/-60	+50/-60	
36"	18"	14"	A, B	+55/-75	+55/-75	+55/-75	+55/-75	+55/-75	+55/-75	+55/-75	
			C, D	+50/-60	+50/-60	+50/-60	+50/-60	+50/-60	+50/-60	+50/-60	
40"	20"	16"	A, B	+55/-75	+55/-75	+55/-75	+55/-75	+55/-75	+55/-75	+55/-75	
			C, D	+50/-60	+50/-60	+50/-60	+50/-60	+50/-60	+50/-60	+50/-60	
44"	22"	18"	A, B	+55/-75	+55/-75	+55/-75	+55/-75	+55/-75	+55/-75	+55/-75	
			C, D	+50/-60	+50/-60	+50/-60	+50/-60	+50/-60	+50/-60	+50/-60	
48"	24"	20"	A, B	+55/-75	+55/-75	+55/-75	+55/-75	+55/-75	+55/-75	+55/-75	
			C, D	+50/-60	+50/-60	+50/-60	+50/-60	+50/-60	+50/-60	+50/-60	
52"	26"	22"	A, B	+55/-75	+55/-75	+55/-75	+55/-75	+55/-75	+55/-75	+55/-75	
			C, D	+50/-60	+50/-60	+50/-60	+50/-60	+50/-60	+50/-60	+50/-60	
56"	28"	24"	A, B	+55/-75	+55/-75	+55/-75	+55/-75	+55/-75	+55/-75	+55/-75	
			C, D	+50/-60	+50/-60	+50/-60	+50/-60	+50/-60	+50/-60	+50/-60	+50/-60
60"	30"	26"	A, B	+55/-75	+55/-75	+55/-75	+55/-75	+55/-75	+55/-75	+55/-75	
			C, D	+50/-60	+50/-60	+50/-60	+50/-60	+50/-60	+50/-60	+50/-60	+50/-60
64"	32"	28"	A, B	+55/-75	+55/-75	+55/-75	+55/-75	+55/-75	+55/-75	+55/-75	
			C, D	+50/-60	+50/-60	+50/-60	+50/-60	+50/-60	+50/-60	+50/-60	+50/-60
68"	34"	30"	A, B	+55/-75	+55/-75	+55/-75	+55/-75	+55/-75	+55/-75	+55/-75	
			C, D	+50/-60	+50/-60	+50/-60	+50/-60	+50/-60	+50/-60	+50/-60	+50/-60
72"	36"	32"	A, B	+55/-75	+55/-75	+55/-75	+55/-75	+55/-75	+55/-75	+55/-75	
			C, D	+50/-60	+50/-60	+50/-60	+50/-60	+50/-60	+50/-60	+50/-60	+50/-60
76"	38"	34"	A, B	+55/-75	+55/-75	+55/-75	+55/-75	+55/-75	+55/-75	+55/-75	
			C, D	+50/-60	+50/-60	+50/-60	+50/-60	+50/-60	+50/-60	+50/-60	+50/-60

3737 Lakeport Blvd
Klamath Falls, OR. 97601
Phone: (541) 882-3451

JELD-WEN

DATE: 05/17/2012
SCALE: NTS
TITLE:

PROJECT ENGINEER: --
DRAWN BY: D. Vezo
CHECKED BY: --
APPROVED BY: --

PART/PROJECT No.: --
IDENTIFIER No. N/A

CAD DWG. No.: JW030
PLANT NAME AND LOCATION: Bend, Oregon

Custom Collection Aluminum Clad Double Hung Window
Design Schedule and Glazing Details

REV: 01

SHEET 3 OF 9

GLAZING TYPE

1/4" LAMINATED, LMI
FOR USE AT ANY HEIGHT ABOVE GRADE

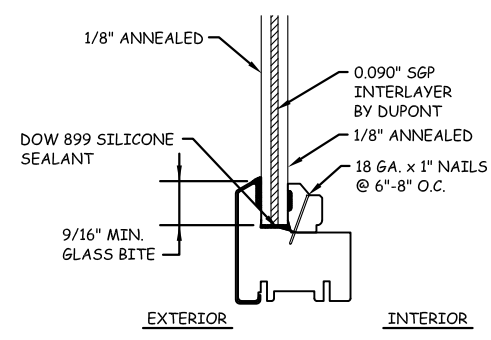

GLAZING TYPE

3/4" INSULATED LAMINATED, LMI
NOT FOR USE ABOVE 30' ABOVE GRADE

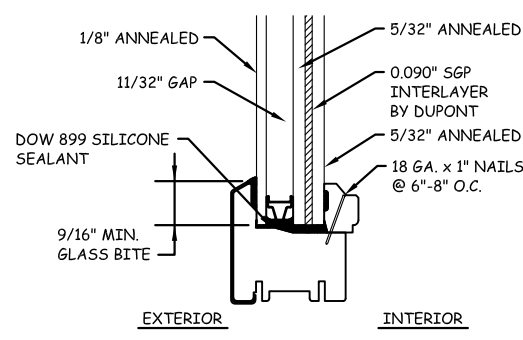

GLAZING TYPE

3/4" INSULATED LAMINATED, LMI
NOT FOR USE ABOVE 30' ABOVE GRADE

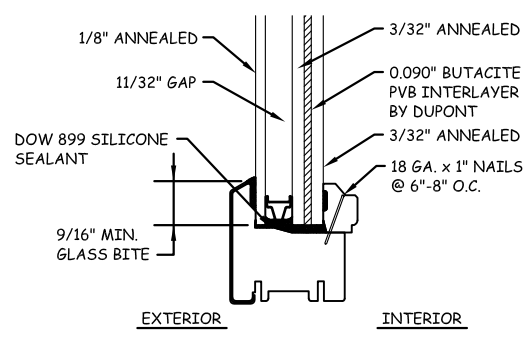

GLAZING TYPE

3/4" INSULATED LAMINATED, LMI
FOR USE AT ANY HEIGHT ABOVE GRADE

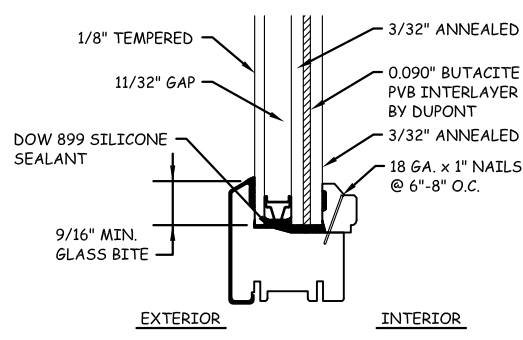

1 3 GLAZING DETAILS

N.T.S. VERTICAL SECTION

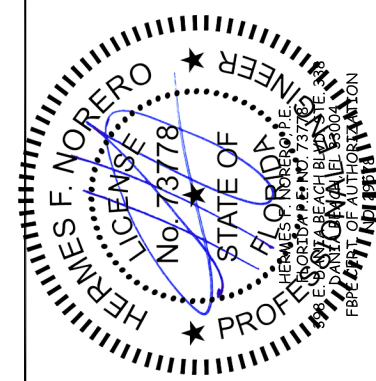

A TYPICAL HEAD ASSEMBLY
4 N.T.S. VERTICAL SECTION

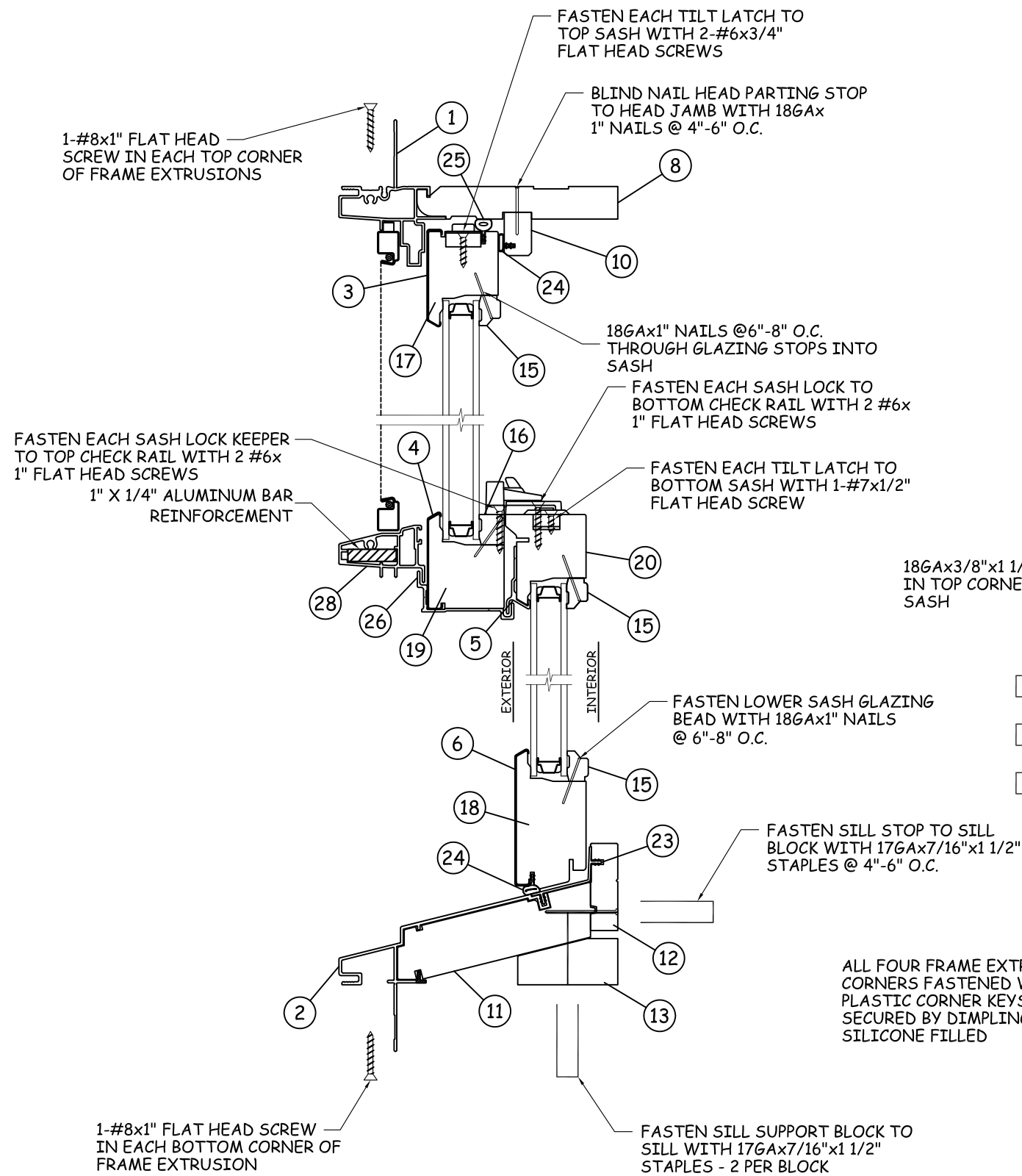

B TYPICAL SILL ASSEMBLY
4 N.T.S. VERTICAL SECTION

REINFORCEMENT NOTES:

- ITEM (31) REQUIRED FOR DESIGN PRESSURES UP TO +50/-60 PSF. BRACKET LOCATED AT TOP OF LOWER SASH AND CORRESPONDING LOCATION ON FRAME. EACH PIECE FASTENED WITH (2) #7 X 5/8" FHSMS.
- ITEM (32) REQUIRED FOR DESIGN PRESSURES EXCEEDING +50/-60 PSF. CLIP LOCATED 3/4" FROM MEETING RAIL AND SILL. FASTENED WITH (1) #8 X 1-1/8" PHSMS WITH T-NUT.
- SEE SHEET 3 FOR DESIGN PRESSURE TABLE.

D TYPICAL JAMB ASSEMBLY
4 N.T.S. HORIZONTAL SECTION

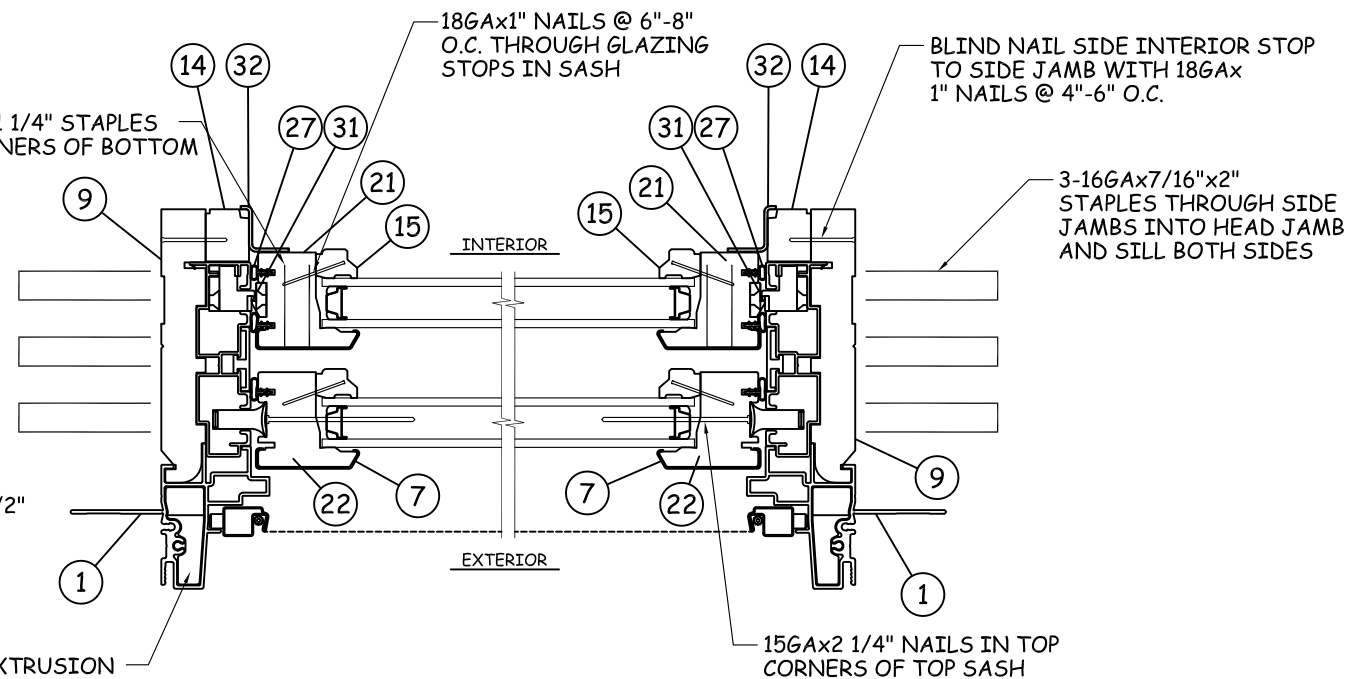

C TYPICAL JAMB ASSEMBLY
4 N.T.S. HORIZONTAL SECTION

3737 Lakeport Blvd
Klamath Falls, OR. 97601
Phone: (541) 882-3451

JELD-WEN

Custom Collection Aluminum Clad Double Hung Window
Assembly Sections

DATE: 05/17/2012
SCALE: NTS
TITLE:

PROJECT ENGINEER: --
DRAWN BY: D. Vezo
CHECKED BY: --
APPROVED BY: --
PART/PROJECT No.: --
IDENTIFIER No.: N/A

CAD DWG. No.: JMW030
PLANT NAME AND LOCATION: Bend, Oregon
REV: 01
SHEET 4 OF 9

INSTALLATION WITH FIN

A AT FRAME HEAD

N.T.S.

VERTICAL SECTION

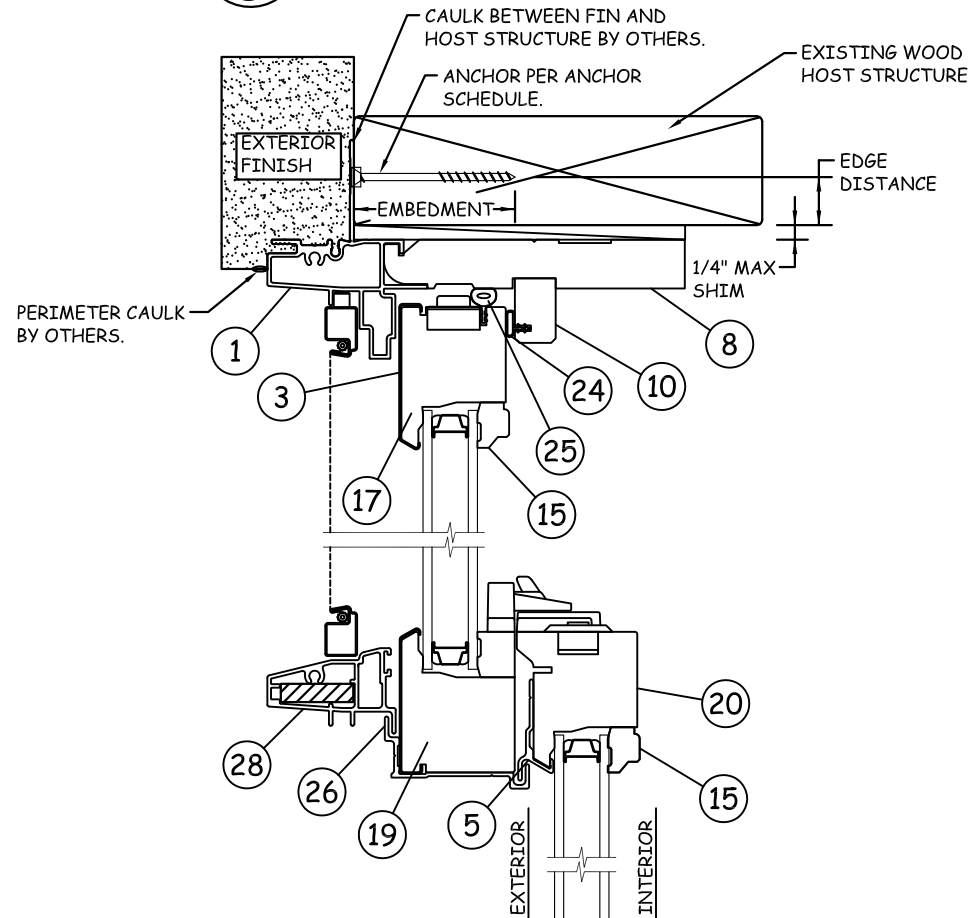

INSTALLATION WITH FIN

D AT FRAME JAMB

N.T.S.

HORIZONTAL SECTION

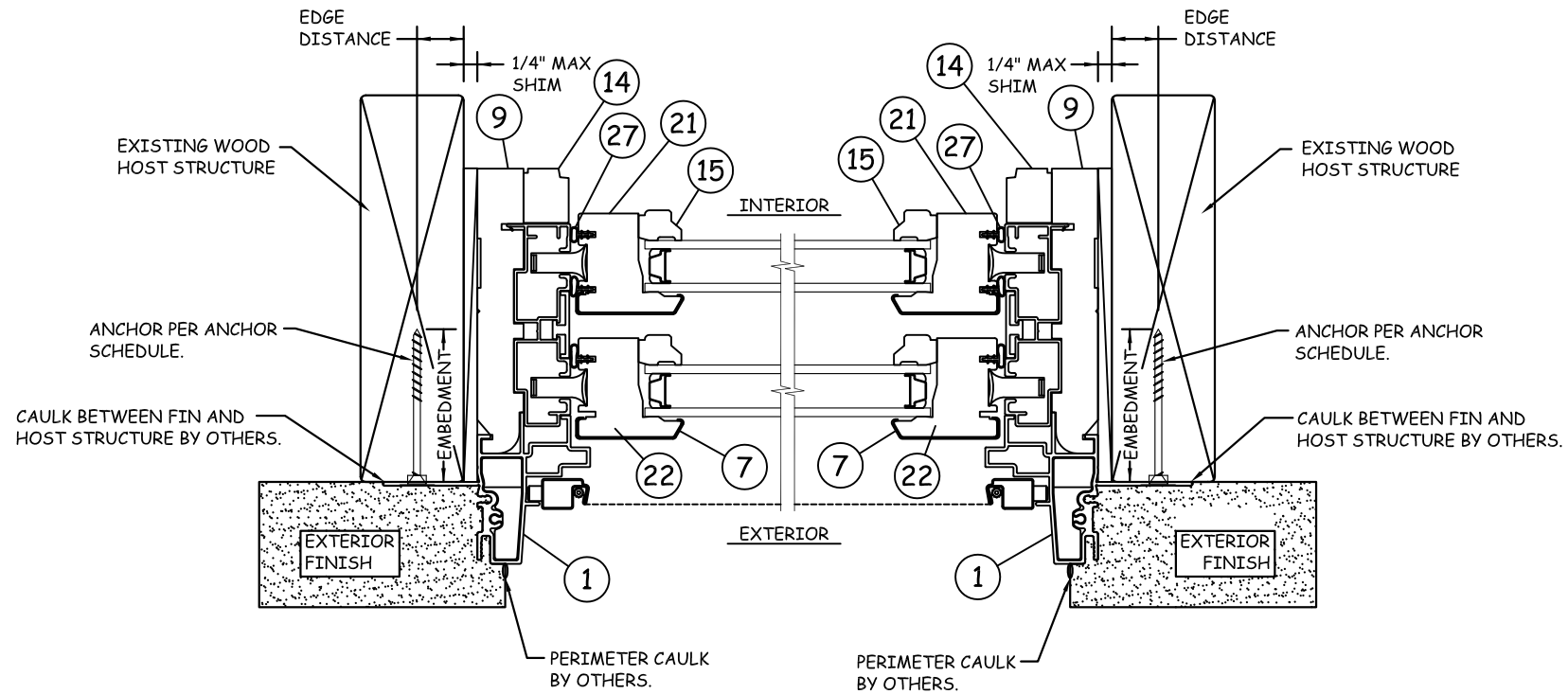

INSTALLATION WITH FIN

C AT FRAME JAMB

N.T.S.

HORIZONTAL SECTION

NOTE: SEE ANCHOR SCHEDULE AND ANCHOR NOTES FOR REQUIRED EDGE DISTANCES AND EMBEDMENTS.

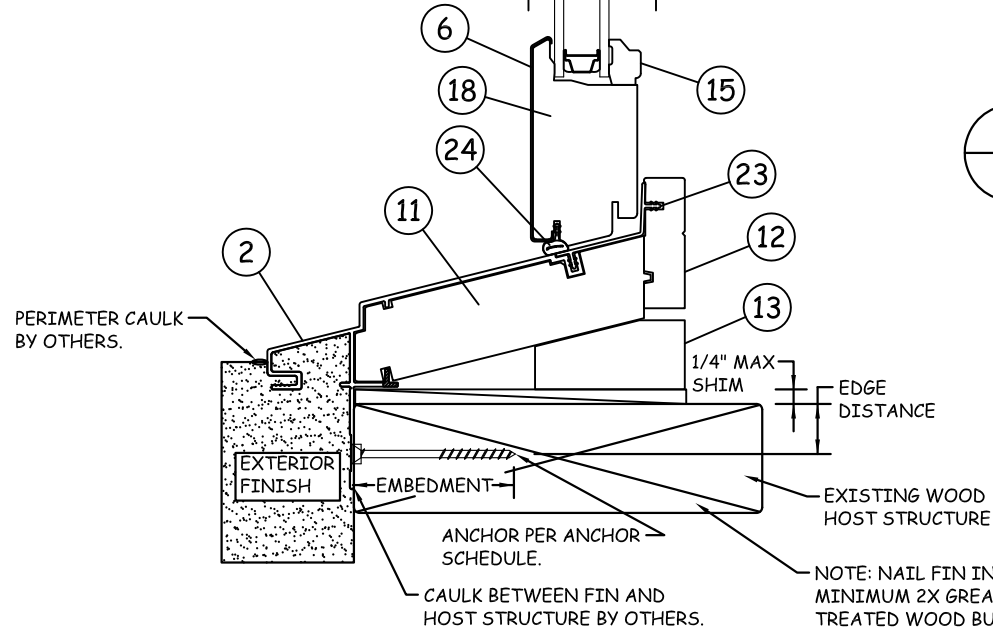

INSTALLATION WITH FIN

B AT FRAME SILL

N.T.S.

VERTICAL SECTION

3737 Lakeport Blvd
Klamath Falls, OR. 97601
Phone: (541) 882-3451

JELD-WEN

Custom Collection Aluminum Clad Double Hung Window
Nail Fin Installation Details

DATE: 05/17/2012
SCALE: NTS

PROJECT ENGINEER: --
DRAWN BY: D. Vezo
CHECKED BY: --
APPROVED BY: --
PART/PROJECT No.: --

TITLE: --

IDENTIFIER No. N/A

PLANT NAME AND LOCATION:
Bend, Oregon

CAD DWG. No.: JW030

REV: 01

SHEET

5 OF 9

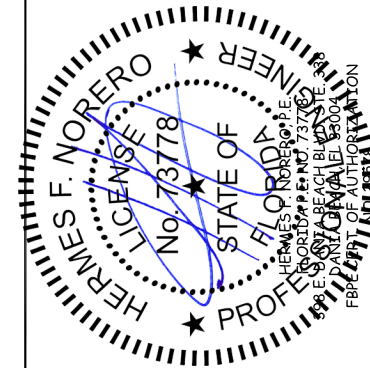

INSTALLATION THROUGH FRAME HEAD

A
6 N.T.S. VERTICAL SECTION

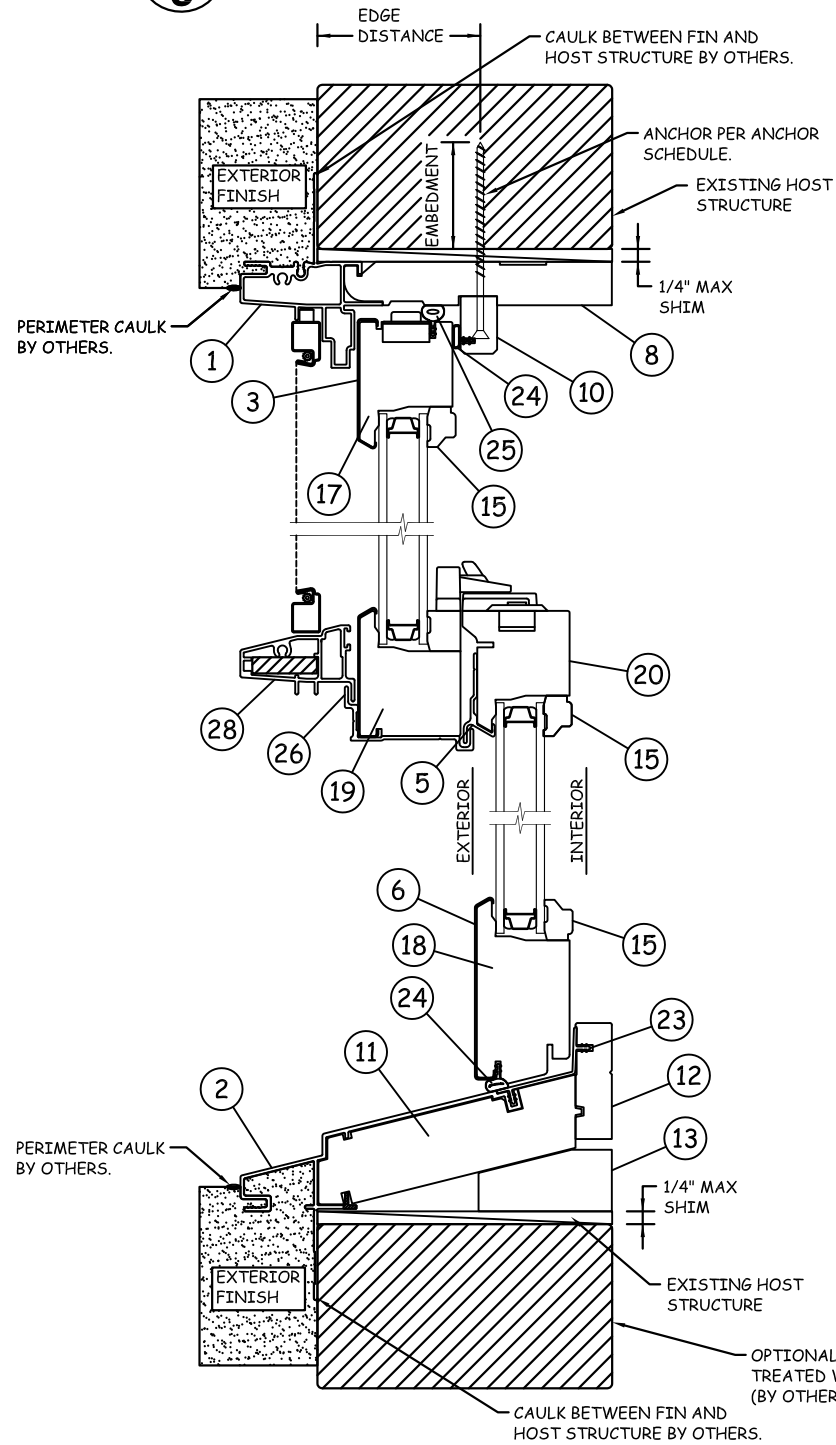

INSTALLATION THROUGH FRAME SILL

B
6 N.T.S. VERTICAL SECTION

INSTALLATION THROUGH FRAME JAMB

D
6 N.T.S. HORIZONTAL SECTION

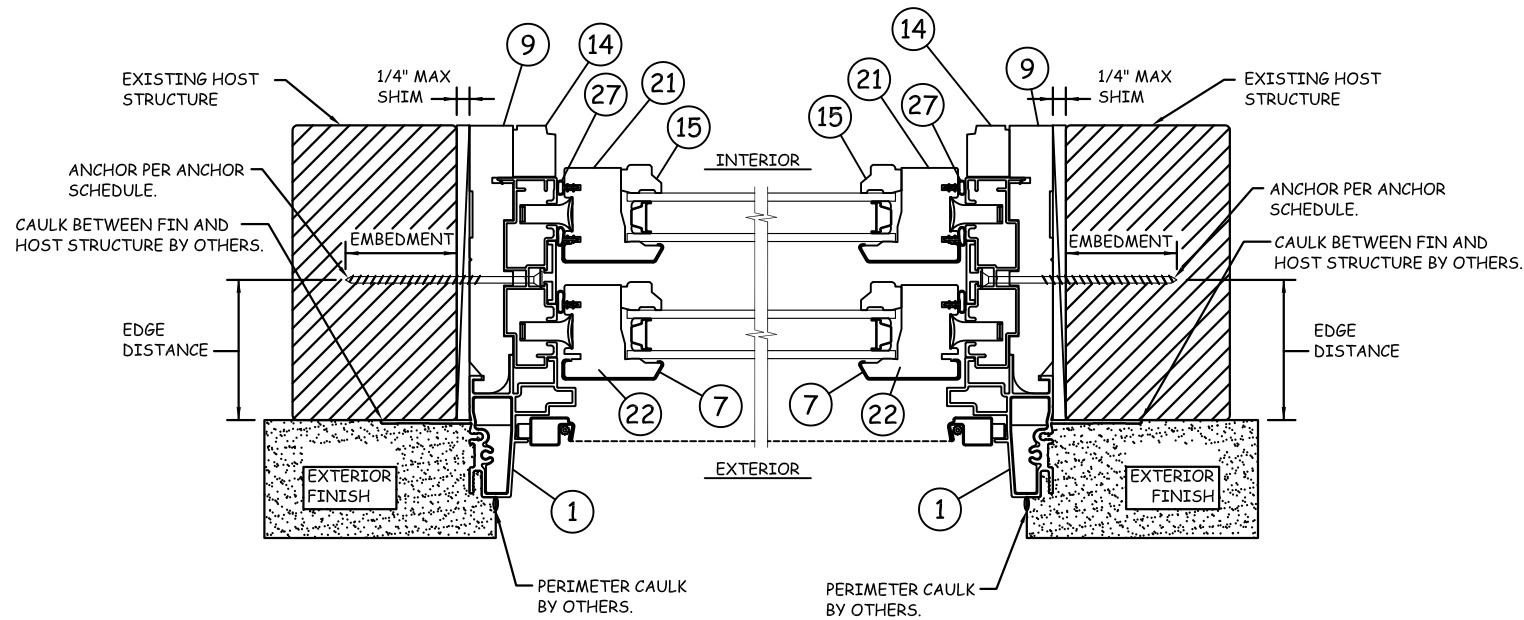

INSTALLATION THROUGH FRAME JAMB

C
6 N.T.S. HORIZONTAL SECTION

NOTE: SEE ANCHOR SCHEDULE AND ANCHOR NOTES FOR REQUIRED EDGE DISTANCES AND EMBEDMENTS.

3737 Lakeport Blvd
Klamath Falls, OR. 97601
Phone: (541) 882-3451

JELD-WEN

DATE: 05/17/2012
SCALE: NTS

PROJECT ENGINEER:
DRAWN BY: D. Vezo
CHECKED BY:
APPROVED BY:
PART/PROJECT No.:

TITLE:

Custom Collection Aluminum Clad Double Hung Window
Through Jamb Installation Details

REV: 01

CAD DWG. No.: JMW030

PLANT NAME AND LOCATION:
Bend, Oregon

IDENTIFIER No.: N/A

SHEET 6 OF 9



INSTALLATION WITH STRAP

A AT FRAME HEAD

N.T.S.

VERTICAL SECTION

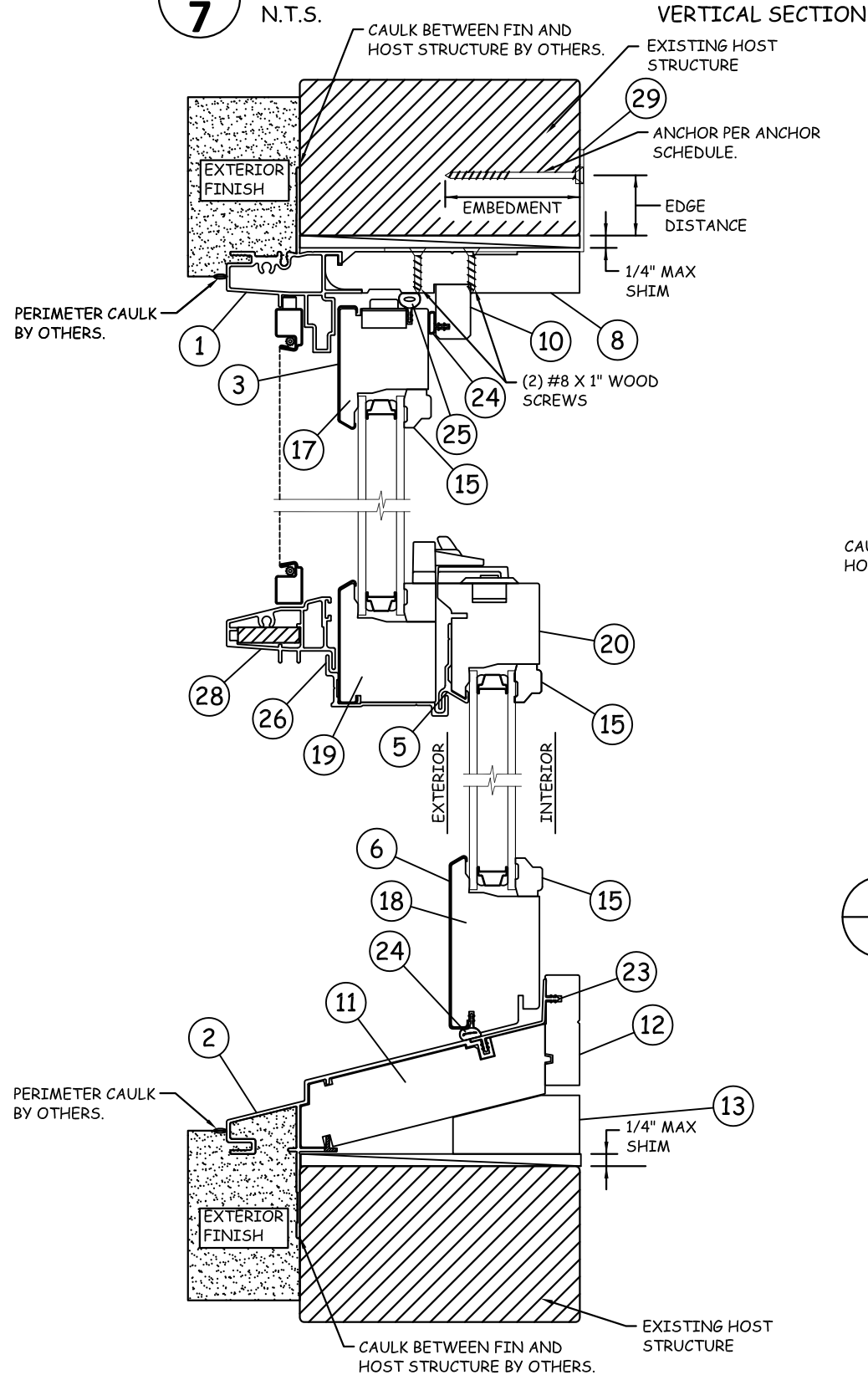

INSTALLATION WITH STRAP

B AT FRAME SILL

N.T.S.

VERTICAL SECTION

INSTALLATION WITH STRAP

D AT FRAME JAMB

N.T.S.

HORIZONTAL SECTION

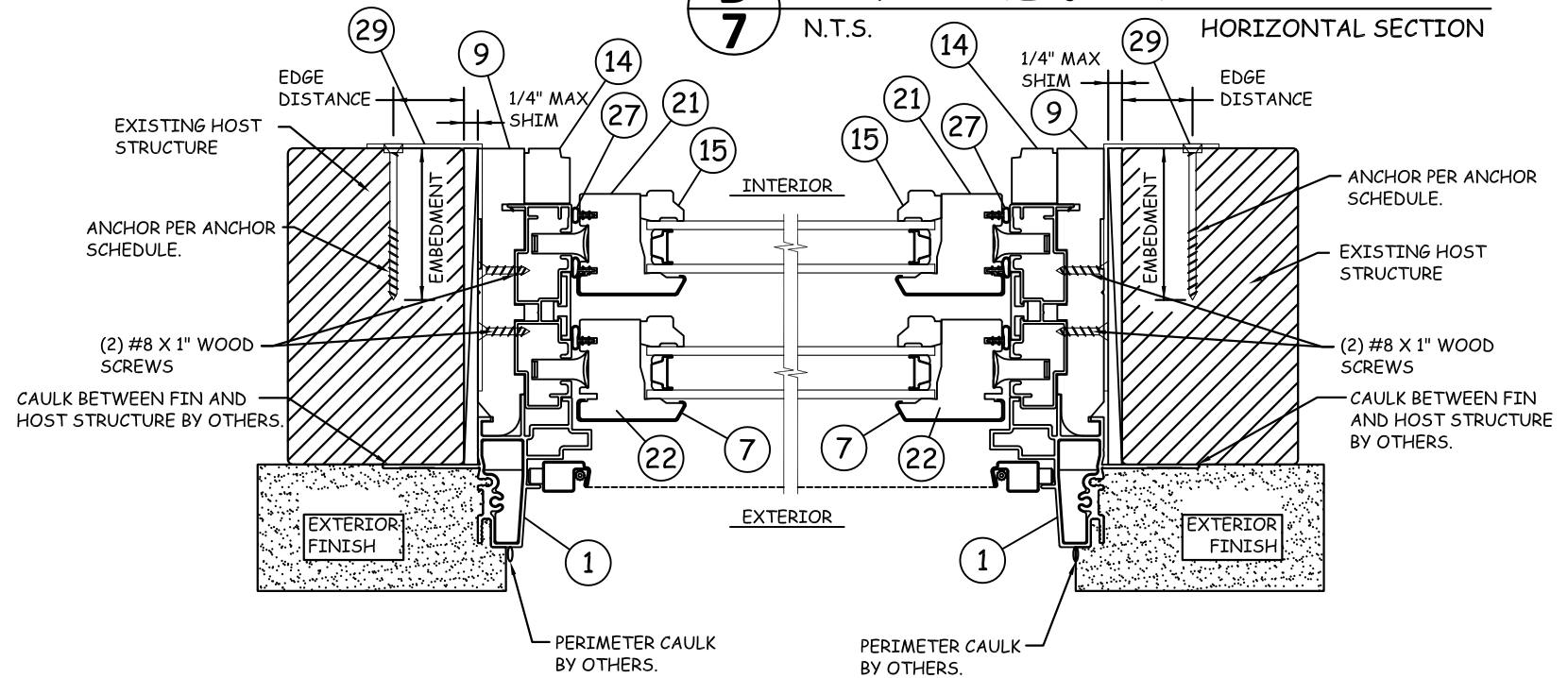

INSTALLATION WITH STRAP

C AT FRAME JAMB

N.T.S.

HORIZONTAL SECTION

NOTE: SEE ANCHOR SCHEDULE AND ANCHOR NOTES FOR REQUIRED EDGE DISTANCES AND EMBEDMENTS.

3737 Lakeport Blvd
Klamath Falls, OR, 97601
Phone: (541) 882-3451

JELD-WEN

Custom Collection Aluminum Clad Double Hung Window
Strap Installation Details

DATE: 05/17/2012

SCALE: NTS

TITLE:

PROJECT ENGINEER:

DRAWN BY: D. Vezo

CHECKED BY:

APPROVED BY:

PART/PROJECT No.:

IDENTIFIER No. N/A

REV: 01

PLANT NAME AND LOCATION:
Bend, Oregon

CAD DWG. No.: JW030

SHEET 7 OF 9

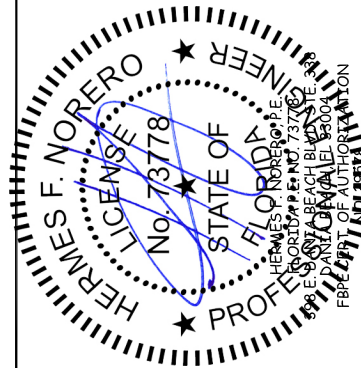

BILL OF MATERIALS

ITEM NO.	DESCRIPTION	PART NUMBER	MATERIAL	MANUFACTURER
1	FRAME CLADDING	VH-53638	ALUMINUM	JELD-WEN
2	FRAME SILL	32781	ALUMINUM	JELD-WEN
3	TOP RAIL CLADDING	1A16047	ALUMINUM	JELD-WEN
4	INTERLOCK CLADDING	1A16047	ALUMINUM	JELD-WEN
5	INTERLOCK CLADDING	VS-55309A	ALUMINUM	JELD-WEN
6	BOTTOM RAIL CLADDING		ALUMINUM	JELD-WEN
7	STILE CLADDING		ALUMINUM	JELD-WEN
8	HEAD JAMB	WF0198HJ	WOOD	JELD-WEN
9	SIDE JAMB	WF0223SJ	WOOD	JELD-WEN
10	HEAD PARTING STOP	WF0377SP	WOOD	JELD-WEN
11	SILL	WF0227SL	WOOD	JELD-WEN
12	SILL STOP	WF0363SP	WOOD	JELD-WEN
13	SILL SUPPORT	WF0299MS	WOOD	JELD-WEN
14	SIDE STOP	WF0437SP	WOOD	JELD-WEN
15	GLAZING STOP	WF0378SP	WOOD	JELD-WEN
16	UPPER CHECK RAIL GLAZING STOP	WF0379SP	WOOD	JELD-WEN

NOTE: ALL WOOD COMPONENTS ARE PRESSURE TREATED AURALAST.

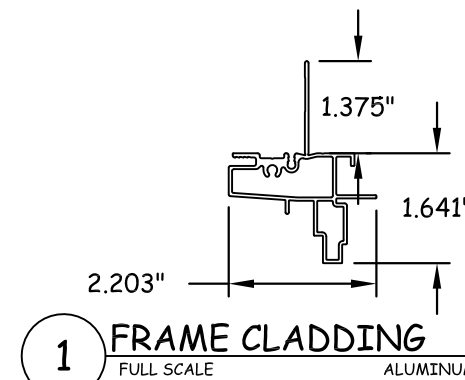

1 FRAME CLADDING
FULL SCALE ALUMINUM

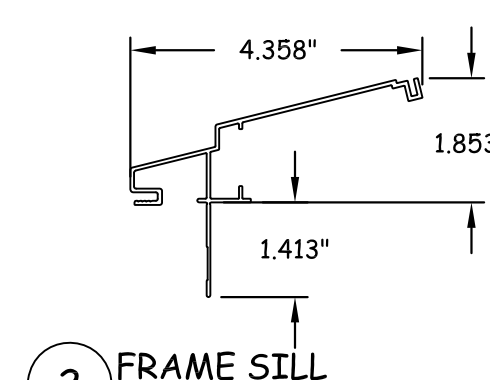

2 FRAME SILL
FULL SCALE ALUMINUM

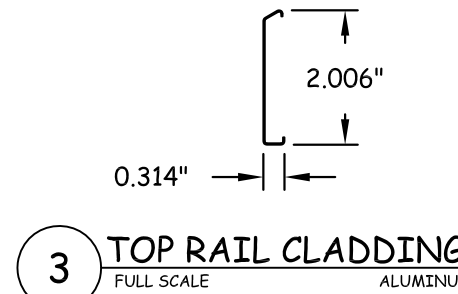

3 TOP RAIL CLADDING
FULL SCALE ALUMINUM

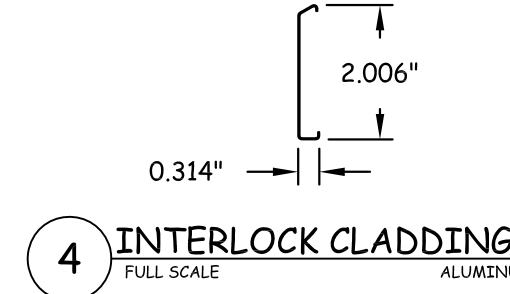

4 INTERLOCK CLADDING
FULL SCALE ALUMINUM

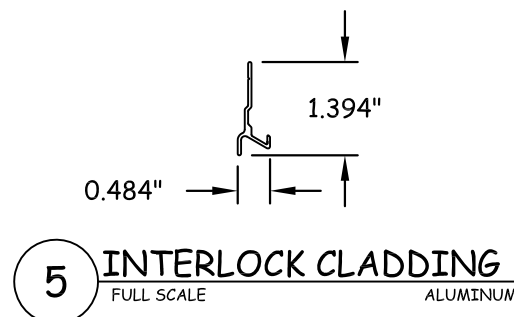

5 INTERLOCK CLADDING
FULL SCALE ALUMINUM

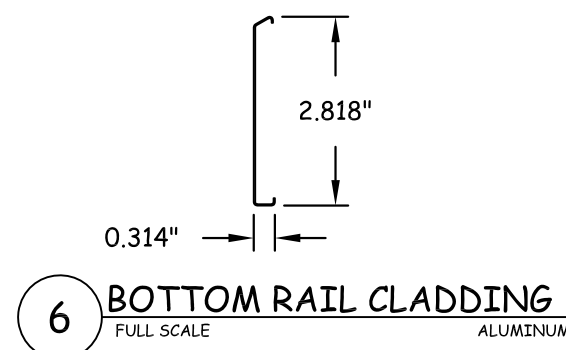

6 BOTTOM RAIL CLADDING
FULL SCALE ALUMINUM

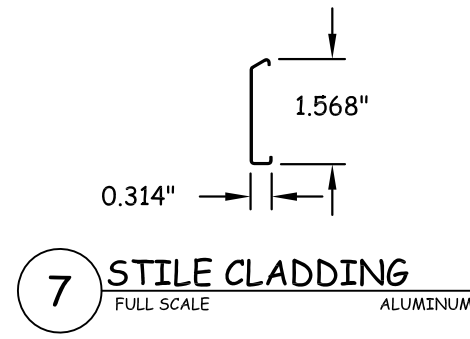

7 STILE CLADDING
FULL SCALE ALUMINUM

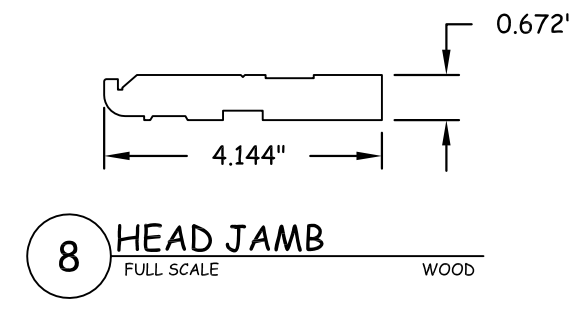

8 HEAD JAMB
FULL SCALE WOOD

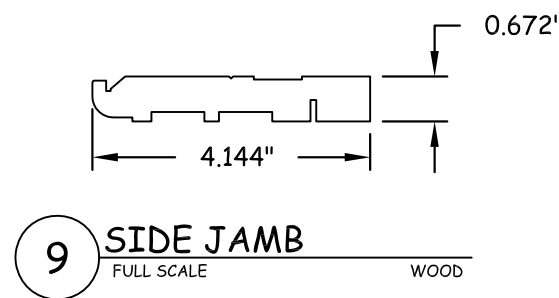

9 SIDE JAMB
FULL SCALE WOOD

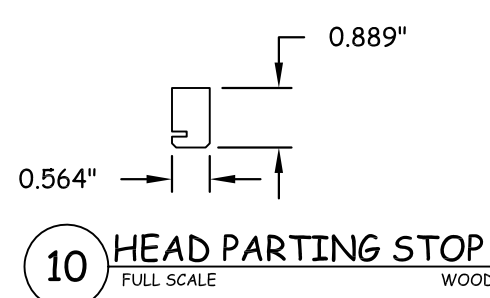

10 HEAD PARTING STOP
FULL SCALE WOOD

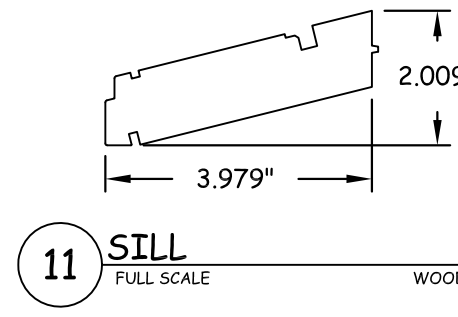

11 SILL
FULL SCALE WOOD

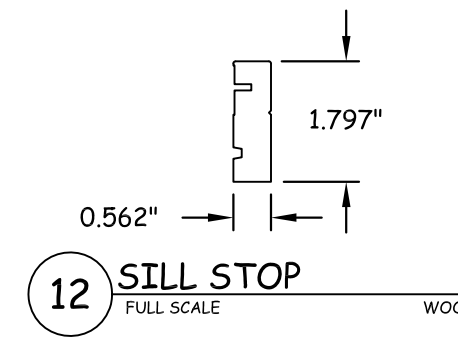

12 SILL STOP
FULL SCALE WOOD

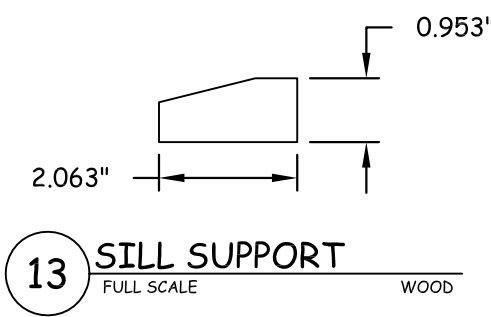

13 SILL SUPPORT
FULL SCALE WOOD

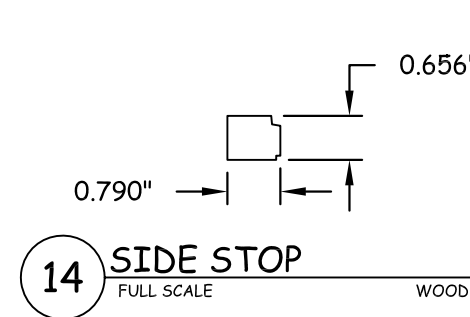

14 SIDE STOP
FULL SCALE WOOD

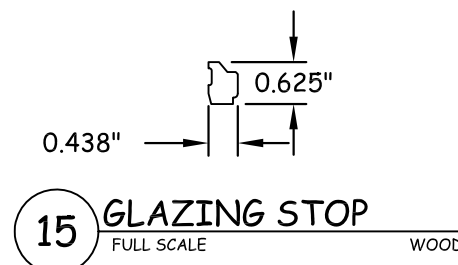

15 GLAZING STOP
FULL SCALE WOOD

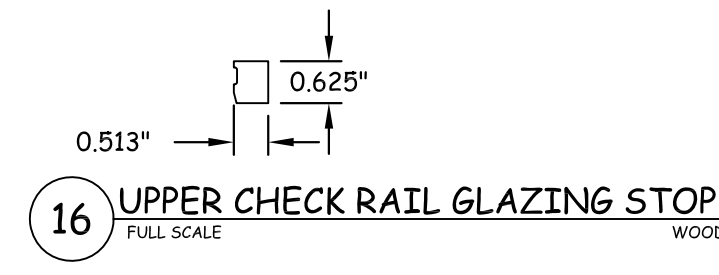

16 UPPER CHECK RAIL GLAZING STOP
FULL SCALE WOOD

JELD-WEN

3737 Lakeport Blvd
Klamath Falls, OR, 97601
Phone: (541) 882-3451

DATE: 05/17/2012
SCALE: NTS
TITLE:

Custom Collection Aluminum Clad Double Hung Window
Components and Bill of Materials

PROJECT ENGINEER: --
DRAWN BY: D. Vezo
CHECKED BY: --
APPROVED BY: --
PART/PROJECT No.: --
IDENTIFIER No. N/A

CAD DWG. No.: JW030
PLANT NAME AND LOCATION:
Bend, Oregon

SHEET 01
8 OF 9

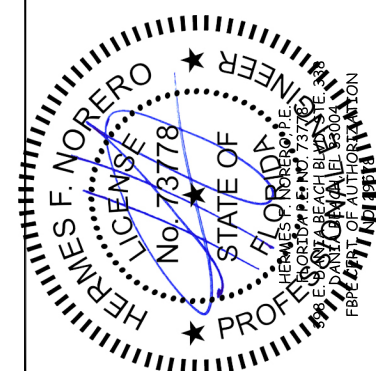

BILL OF MATERIALS

ITEM NO.	DESCRIPTION	PART NUMBER	MATERIAL	MANUFACTURER
17	TOP RAIL	WF0335RA	WOOD	JELD-WEN
18	BOTTOM RAIL	WF0336RA	WOOD	JELD-WEN
19	UPPER SASH INTERLOCK	WF0355RA	WOOD	JELD-WEN
20	LOWER SASH INTERLOCK	WF0356RA	WOOD	JELD-WEN
21	STILE	WF0251ST	WOOD	JELD-WEN
22	STILE	WF0252ST	WOOD	JELD-WEN
23	SILL LINER	V01899	PVC	JELD-WEN
24	FRAME WEATHERSTRIP	12402	PVC	JELD-WEN
25	SASH WEATHERSTRIP	12094	PVC	JELD-WEN
26	INTERLOCK CLADDING	VS-55308A	ALUMINUM	JELD-WEN
27	SASH WEATHERSTRIP		PVC	JELD-WEN
28	INTERLOCK CLADDING	VS-55310	ALUMINUM	JELD-WEN
29	13 GA. INSTALL STRAP		STEEL	JELD-WEN
30	SILICONE SEALANT		SEALANT	DOW CORNING 899
31	IMPACT BRACKET		DELTRIN POM	JELD-WEN
32	WIND CLIP		ALUMINUM	JELD-WEN

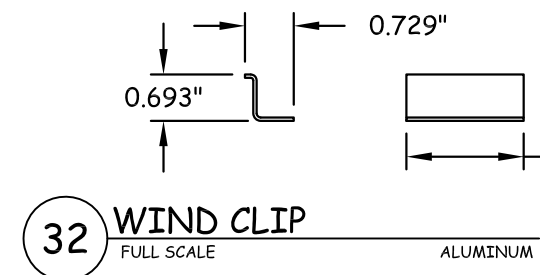
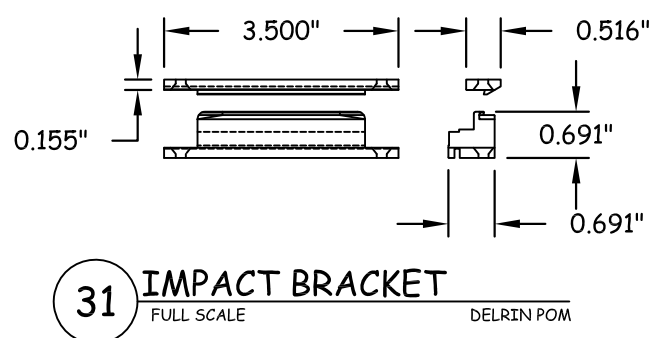
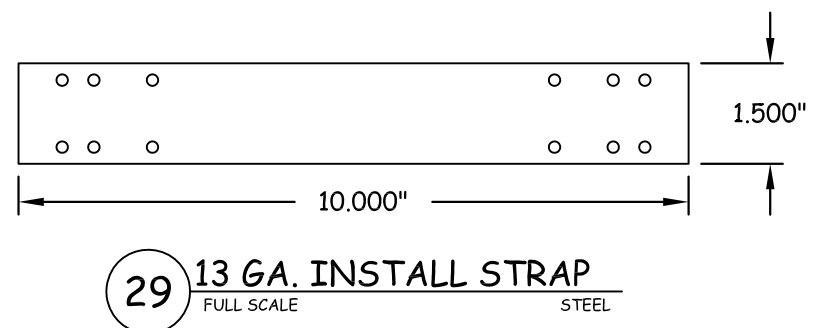
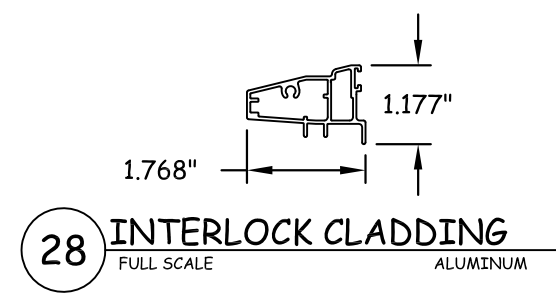
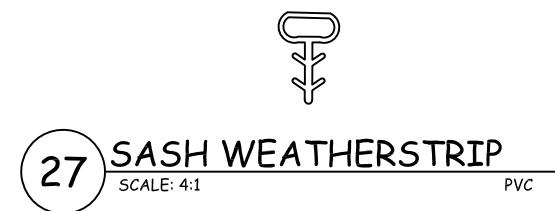
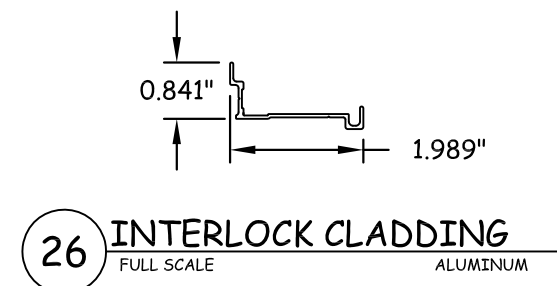
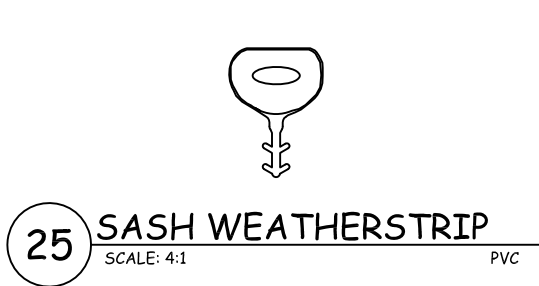
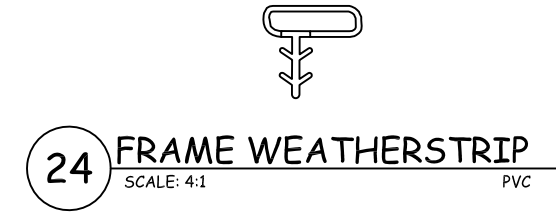
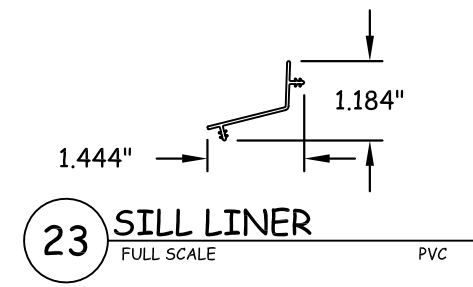
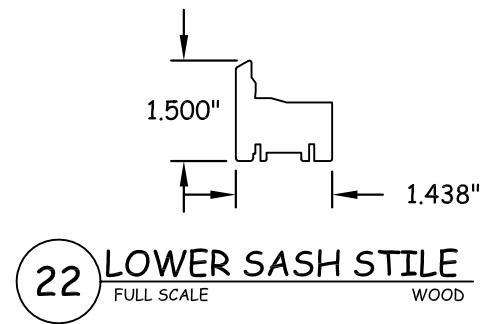
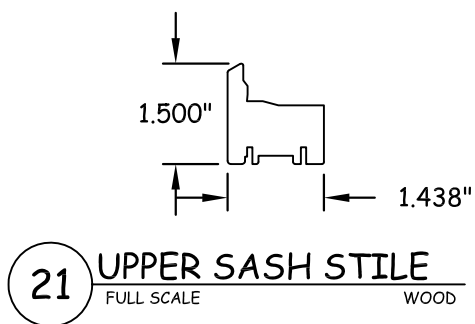
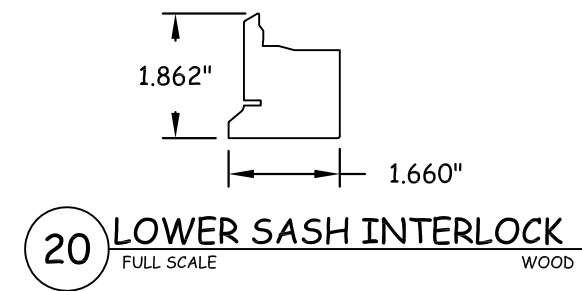
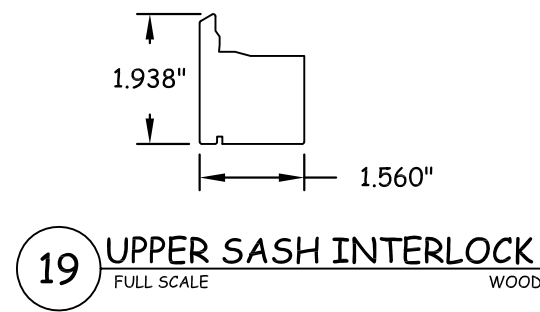
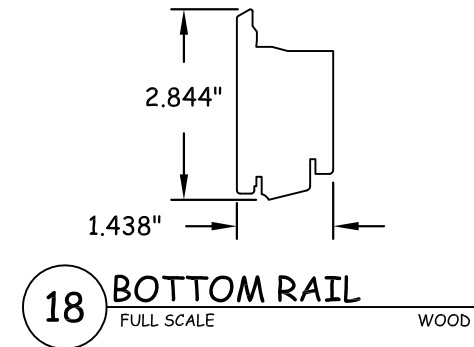
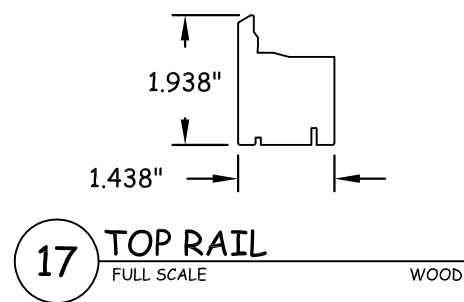

JELD-WEN

3737 Lakeport Blvd
Klamath Falls, OR, 97601
Phone: (541) 882-3451

Custom Collection Aluminum Clad Double Hung Window
Components and Bill of Materials

SHEET 9 OF 9

REV: 01

CAD DWG. No.: JMW030

PLANT NAME AND LOCATION:
Bend, Oregon

PROJECT ENGINEER: --

DRAWN BY: D. Vezo

CHECKED BY: --

APPROVED BY: --

PART/PROJECT No.: --

IDENTIFIER No.: N/A

DATE: 05/17/2012

SCALE: NTS

TITLE: --
