

REVISIONS			
REV	DESCRIPTION	DATE	APPROVED
B	CHANGE MANUFACTURER'S NAME	03/29/2023	R.L.

NOTES:

1. THE PRODUCT SHOWN HEREIN IS DESIGNED AND MANUFACTURED TO COMPLY WITH REQUIREMENTS OF THE FLORIDA BUILDING CODE.
2. WOOD FRAMING AND MASONRY OPENING TO BE DESIGNED AND ANCHORED TO PROPERLY TRANSFER ALL LOADS TO STRUCTURE. FRAMING AND MASONRY OPENING IS THE RESPONSIBILITY OF THE ARCHITECT OR ENGINEER OF RECORD.
3. WHERE SHIM OR BUCK THICKNESS IS LESS THAN 1-1/2" UNITS MUST BE ANCHORED THROUGH THE FRAME IN ACCORDANCE WITH MANUFACTURER'S PUBLISHED INSTALLATION INSTRUCTIONS. ANCHORS SHALL BE SECURELY FASTENED DIRECTLY INTO MASONRY, CONCRETE OR OTHER STRUCTURAL SUBSTRATE MATERIAL.
4. WHERE WOOD BUCK THICKNESS IS 1-1/2" OR GREATER, BUCK SHALL BE SECURELY FASTENED TO MASONRY, CONCRETE OR OTHER STRUCTURAL SUBSTRATE. UNITS MAY BE ANCHORED THROUGH FRAME TO SECURED WOOD BUCK IN ACCORDANCE WITH MANUFACTURER'S PUBLISHED INSTALLATION INSTRUCTIONS.
5. WHERE 1X BUCK IS NOT USED DISSIMILAR MATERIALS MUST BE SEPARATED WITH APPROVED COATING OR MEMBRANE. SELECTION OF COATING OR MEMBRANE IS THE RESPONSIBILITY OF THE ARCHITECT OR ENGINEER OF RECORD.
6. BUCKS SHALL EXTEND BEYOND UNIT FRAME INTERIOR FACE SO THAT FULL FRAME SUPPORT IS PROVIDED.
7. SHIM AS REQUIRED AT EACH ANCHOR LOCATION WITH LOAD BEARING SHIM. SHIM WHERE SPACE OF 1/16" OR GREATER OCCURS. MAXIMUM ALLOWABLE SHIM STACK TO BE 1/2".
8. SHIMS SHALL BE LOCATED, APPLIED AND MADE FROM MATERIALS AND THICKNESS CAPABLE OF SUSTAINING APPLICABLE LOADS.
9. WIND LOAD DURATION FACTOR $C_d=1.6$ WAS USED FOR WOOD ANCHOR CALCULATIONS.
10. FRAME MATERIAL: EXTRUDED ALUMINUM 6063-T5.
11. UNITS MUST BE GLAZED PER ASTM E1300.
12. APPROVED IMPACT PROTECTIVE SYSTEM IS REQUIRED FOR THIS PRODUCT IN WIND BORNE DEBRIS REGIONS.
13. FOR ANCHORING THROUGH FRAME INTO WOOD FRAMING OR 2X BUCK USE #12 WOOD SCREWS WITH SUFFICIENT LENGTH TO ACHIEVE A 1 1/4" MINIMUM EMBEDMENT INTO SUBSTRATE. LOCATE ANCHORS AS SHOWN IN ELEVATIONS AND INSTALLATION DETAILS.

14. FOR ANCHORING THROUGH FRAME INTO MASONRY/CONCRETE USE 1/4" TAPCONS WITH SUFFICIENT LENGTH TO ACHIEVE A 1 1/4" MINIMUM EMBEDMENT INTO SUBSTRATE WITH 2" MINIMUM EDGE DISTANCE. LOCATE ANCHORS AS SHOWN IN ELEVATIONS AND INSTALLATION DETAILS.
15. FOR ANCHORING THROUGH FRAME INTO METAL STRUCTURE USE #12 SMS OR SELF DRILLING SCREWS WITH SUFFICIENT LENGTH TO ACHIEVE 3 THREADS MINIMUM BEYOND STRUCTURE INTERIOR WALL. LOCATE ANCHORS AS SHOWN IN ELEVATIONS AND INSTALLATION DETAILS.
16. ALL FASTENERS TO BE CORROSION RESISTANT.
17. INSTALLATION ANCHORS SHALL BE INSTALLED IN ACCORDANCE WITH ANCHOR MANUFACTURER'S INSTALLATION INSTRUCTIONS AND ANCHORS SHALL NOT BE USED IN SUBSTRATES WITH STRENGTHS LESS THAN THE MINIMUM STRENGTH SPECIFIED BELOW:
 - A. WOOD: MINIMUM SPECIFIC GRAVITY OF $G=0.42$
 - B. CONCRETE: MINIMUM COMPRESSIVE STRENGTH OF 2,000 PSI.
 - C. MASONRY: HOLLOW/FILLED BLOCK PER ASTM C90 WITH $F_m=2,000$ PSI MINIMUM.
 - D. METAL STRUCTURE: STEEL 18GA (.048") $F_y=33$ KSI/ $F_u=52$ KSI OR ALUMINUM 6063-T5 $F_u=30$ KSI 1/8" THICK MINIMUM

SIGNED: 03/29/2023

TABLE OF CONTENTS	
SHEET NO.	DESCRIPTION
1	NOTES
2	ELEVATIONS
3 - 4	INSTALLATION DETAILS
5	COMPONENTS

US ALUMINUM 950 SOLON RD. WAXAHACHIE, TX 75165		
SERIES 400 ALUMINUM MEDIUM STILE DOOR 48" X 98" PANEL NOTES		
DRAWN: A.P.	DWG NO. 08-01801	REV B
SCALE NTS	DATE 10/01/12	SHEET 1 OF 5
L. ROBERTO LOMAS P.E. 400 S. PALM AVE, INDIALANTIC, FL 32903 434-688-0609 rllomas@rlomaspe.com		

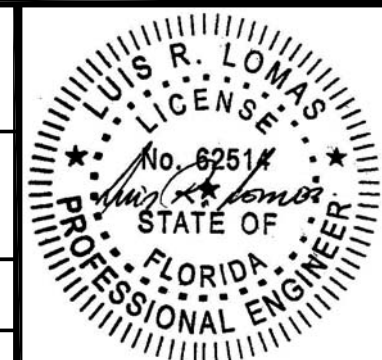

Luis R. Lomas P.E.
FL No.: 62514

REVISIONS			
REV	DESCRIPTION	DATE	APPROVED
B	CHANGE MANUFACTURER'S NAME	03/29/2023	R.L.

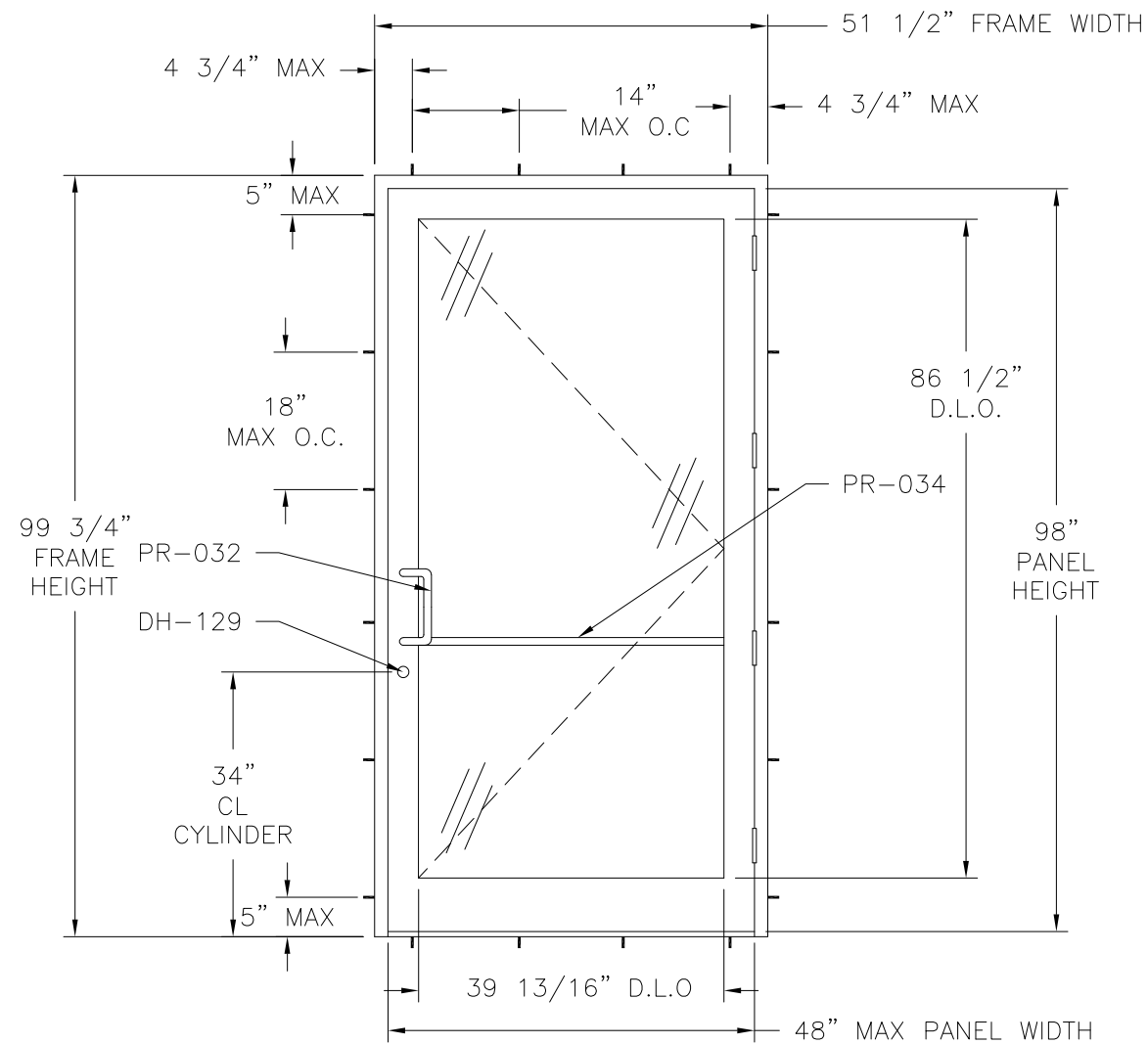

SERIES 400 ALUMINUM MEDIUM STILE DOOR
EXTERIOR VIEW FRAME FLUSH INSTALLATION

DESIGN PRESSURE RATING	IMPACT RATING
±31.0PSF	NONE
THIS SYSTEM WAS NOT TESTED FOR WATER INFILTRATION AND IS TO BE INSTALLED ONLY WHERE THE WATER REQUIREMENT IS NOT NEEDED	

FOR OTHER SIZES APPROVED, SEE CHART #1 THIS SHEET

HARDWARE SCHEDULE
A. PR-032 PULL HANDLE
B. PR-034 PUSH BAR
C. DH-129 HOOK BOLT LOCK
D. (4) DH-009 FIVE BARREL STAINLES STEEL HINGE

SEE CHART #1

Panel Height (in)	Maximum design pressure capacity chart (psf)											
	Panel width (in)											
	28.0		32.0		36.0		40.0		44.0		48.0	
	Pos	Neg	Pos	Neg	Pos	Neg	Pos	Neg	Pos	Neg	Pos	Neg
78.0	48.9	48.9	44.2	44.2	40.6	40.6	37.8	37.8	35.6	35.6	33.8	33.8
80.0	48.6	48.6	43.9	43.9	40.3	40.3	37.5	37.5	35.2	35.2	33.4	33.4
82.0	48.4	48.4	43.6	43.6	40.0	40.0	37.2	37.2	34.9	34.9	33.1	33.1
84.0	48.2	48.2	43.4	43.4	39.7	39.7	36.9	36.9	34.6	34.6	32.8	32.8
86.0	47.9	47.9	43.1	43.1	39.5	39.5	36.6	36.6	34.3	34.3	32.5	32.5
88.0	47.7	47.7	42.9	42.9	39.2	39.2	36.4	36.4	34.0	34.0	32.2	32.2
90.0	47.5	47.5	42.7	42.7	39.0	39.0	36.1	36.1	33.8	33.8	31.9	31.9
92.0	47.3	47.3	42.5	42.5	38.8	38.8	35.9	35.9	33.6	33.6	31.7	31.7
94.0	47.2	47.2	42.3	42.3	38.6	38.6	35.7	35.7	33.3	33.3	31.4	31.4
96.0	47.0	47.0	42.1	42.1	38.4	38.4	35.5	35.5	33.1	33.1	31.2	31.2
98.0	46.8	46.8	42.0	42.0	38.2	38.2	35.3	35.3	32.9	32.9	31.0	31.0

SIGNED: 03/29/2023

US ALUMINUM
950 SOLON RD.
WAXAHACHIE, TX 75165

SERIES 400 ALUMINUM MEDIUM STILE DOOR
48" X 98" PANEL
ELEVATIONS

DRAWN: A.P.	DWG NO. 08-01801	REV B
SCALE NTS	DATE 10/01/12	SHEET 2 OF 5

L. ROBERTO LOMAS P.E.
400 S. PALM AVE, INDIALANTIC, FL 32903
434-688-0609 rllomas@rlomaspe.com

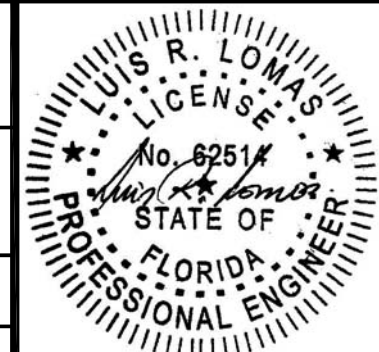

Luis R. Lomas P.E.
FL No.: 62514

REVISIONS			
REV	DESCRIPTION	DATE	APPROVED
B	CHANGE MANUFACTURER'S NAME	03/29/2023	R.L.

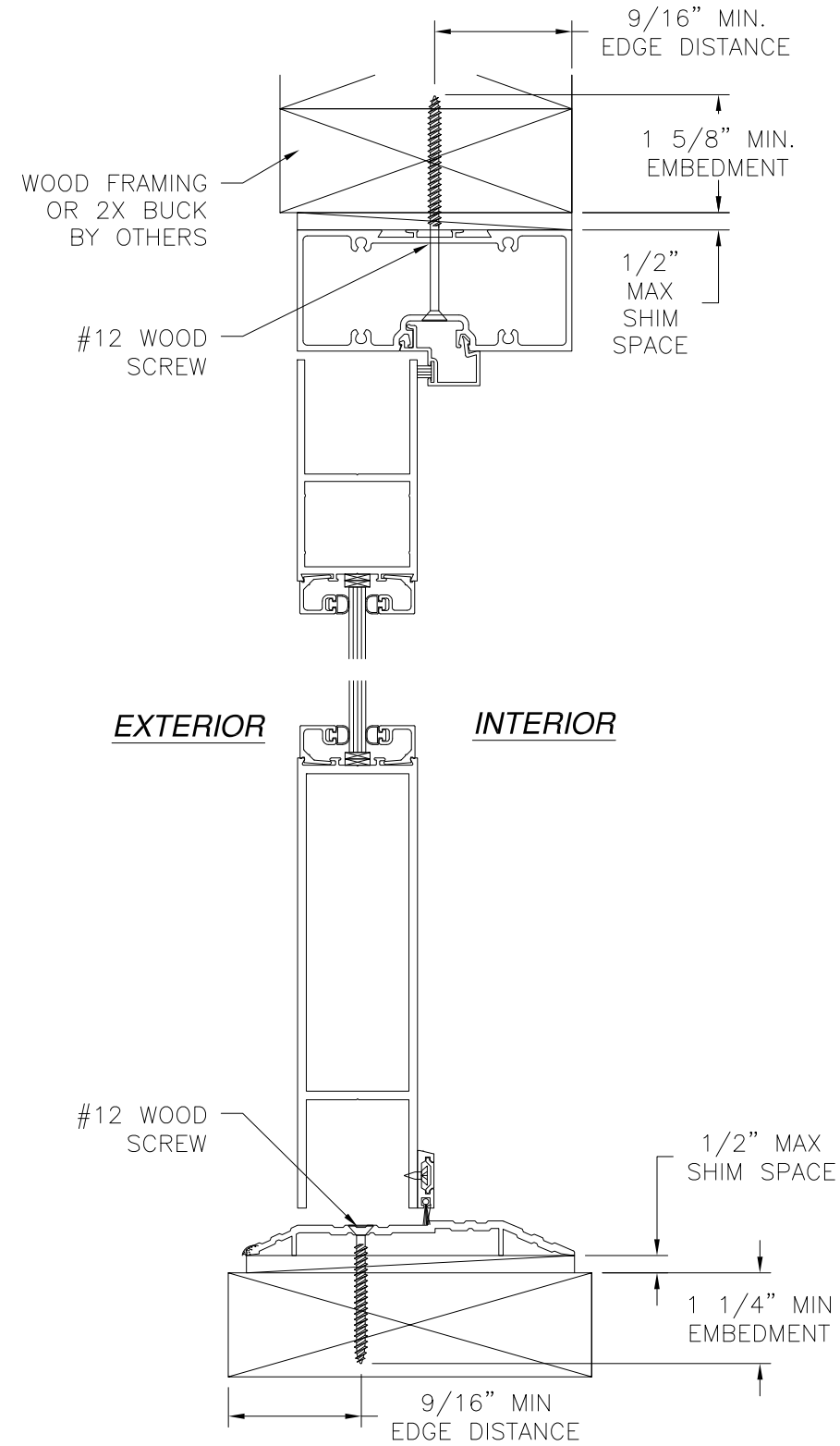

VERTICAL CROSS SECTION
WOOD FRAMING OR 2X BUCK INSTALLATION

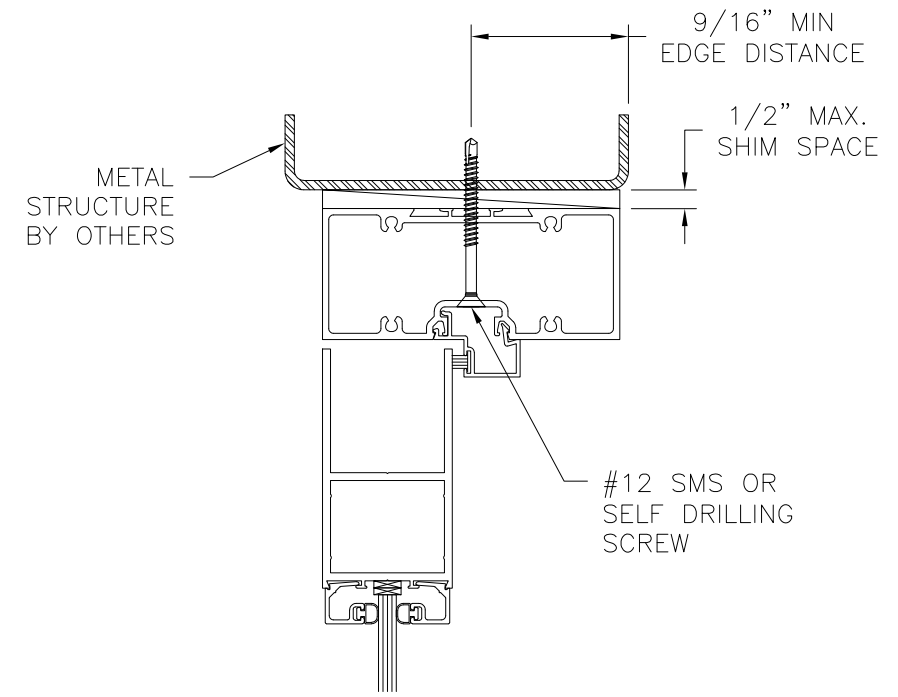

VERTICAL CROSS SECTION
METAL STRUCTURE INSTALLATION

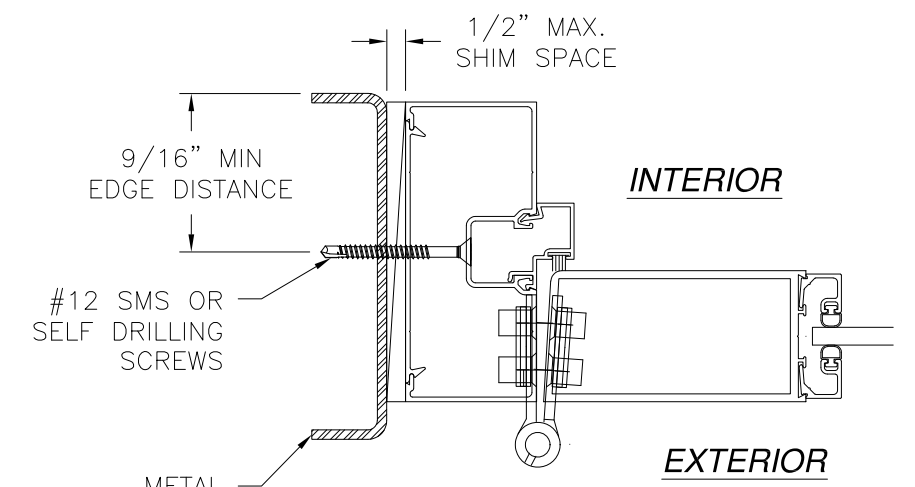

JAMB INSTALLATION DETAIL
METAL STRUCTURE INSTALLATION

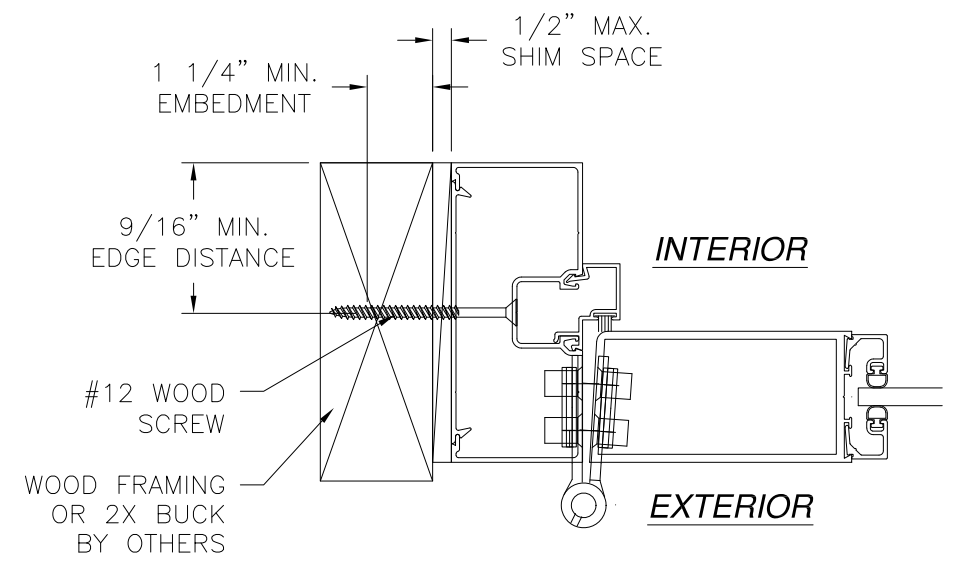

JAMB INSTALLATION DETAIL
WOOD FRAMING OR 2X BUCK INSTALLATION

NOTES:
 1. INTERIOR AND EXTERIOR FINISHES, BY OTHERS, NOT SHOWN FOR CLARITY.
 2. PERIMETER AND JOINT SEALANT BY OTHERS TO BE DESIGNED IN ACCORDANCE WITH ASTM E2112

SIGNED: 03/29/2023

US ALUMINUM
 950 SOLON RD.
 WAXAHACHIE, TX 75165

SERIES 400 ALUMINUM MEDIUM STILE DOOR
 48" X 98" PANEL
 INSTALLATION DETAILS

DRAWN: A.P.	DWG NO. 08-01801	REV B
SCALE NTS	DATE 10/01/12	SHEET 3 OF 5

L. ROBERTO LOMAS P.E.
 400 S. PALM AVE, INDIALANTIC, FL 32903
 434-688-0609 rllomas@rlomaspe.com

Luis R. Lomas P.E.
 FL No.: 62514

REVISIONS			
REV	DESCRIPTION	DATE	APPROVED
B	CHANGE MANUFACTURER'S NAME	03/29/2023	R.L.

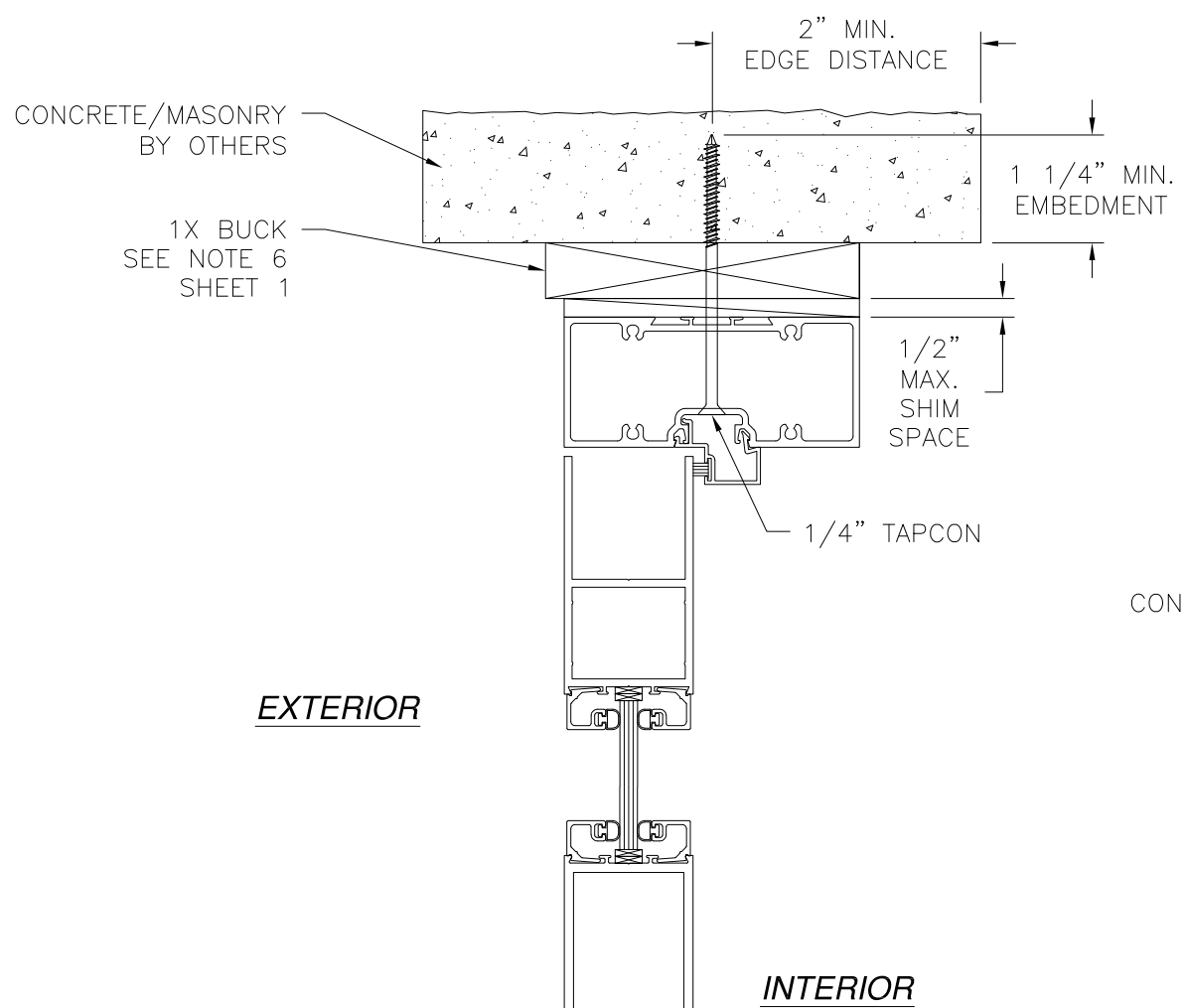

VERTICAL CROSS SECTION
 CONCRETE/MASONRY INSTALLATION WITH 1X BUCK INSTALLATION
 FOR CONCRETE/MASONRY WITHOUT 1X BUCK REFER TO JAMB
 INSTALLATION DETAILS

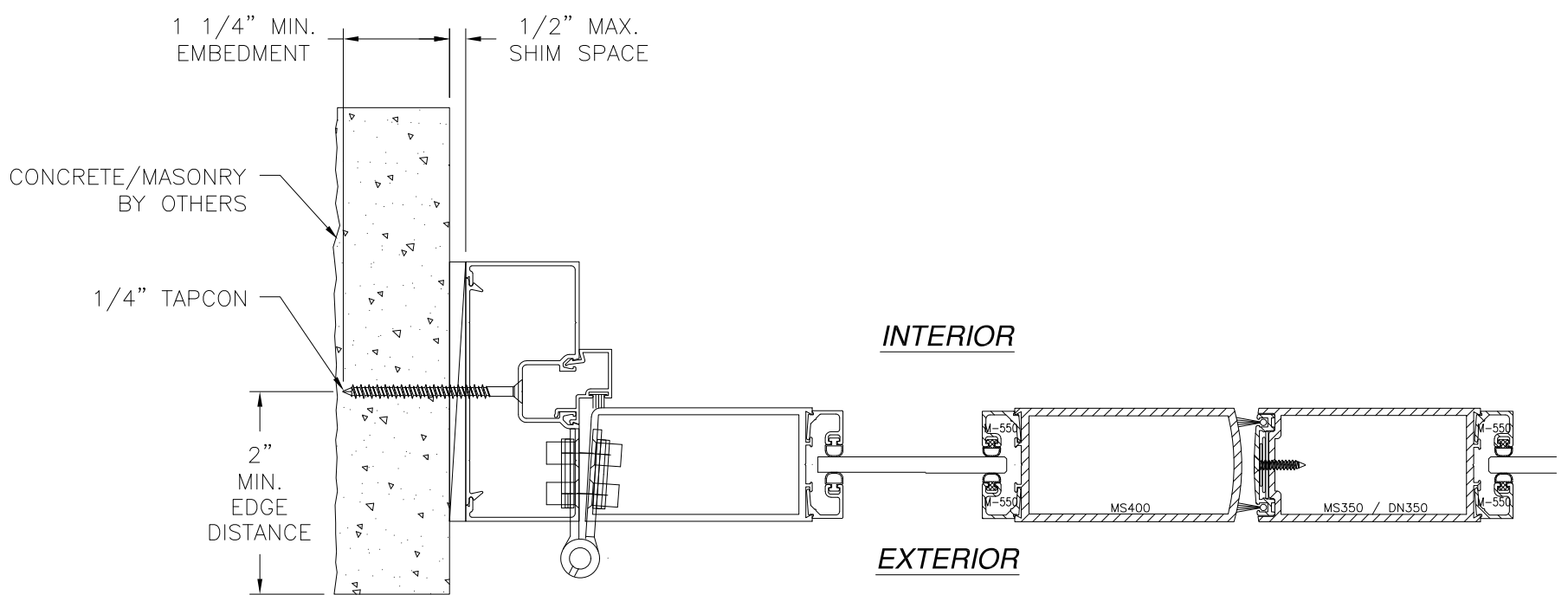

JAMB INSTALLATION DETAIL
 CONCRETE/MASONRY WITHOUT 1X BUCK INSTALLATION
 FOR CONCRETE/MASONRY INSTALLATION WITH 1X BUCK REFER
 TO HEAD AND SILL INSTALLATION DETAILS

- NOTES:**
1. INTERIOR AND EXTERIOR FINISHES, BY OTHERS, NOT SHOWN FOR CLARITY.
 2. PERIMETER AND JOINT SEALANT BY OTHERS TO BE DESIGNED IN ACCORDANCE WITH ASTM E2112

US ALUMINUM
 950 SOLON RD.
 WAXAHACHIE, TX 75165

SERIES 400 ALUMINUM MEDIUM STILE DOOR
 48" X 98" PANEL
 INSTALLATION DETAILS

DRAWN: A.P.	DWG NO. 08-01801	REV B
SCALE NTS	DATE 10/01/12	SHEET 4 OF 5

L. ROBERTO LOMAS P.E.
 400 S. PALM AVE, INDIALANTIC, FL 32903
 434-688-0609 rllomas@lrlomaspe.com

SIGNED: 03/29/2023

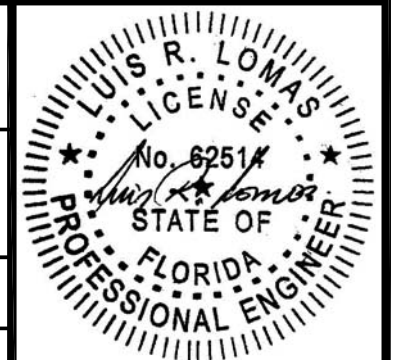

Luis R. Lomas P.E.
 FL No.: 62514

REVISIONS			
REV	DESCRIPTION	DATE	APPROVED
B	CHANGE MANUFACTURER'S NAME	03/29/2023	R.L.

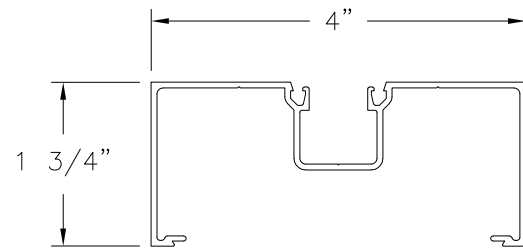

JAMB
ALUMINUM 6063-T5 (J-402)

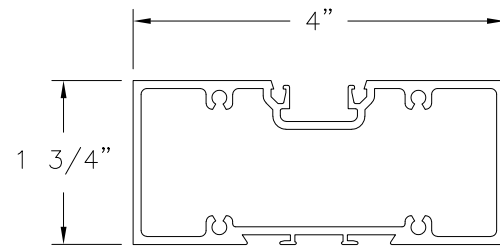

HEAD
ALUMINUM 6063-T5 (JS417)

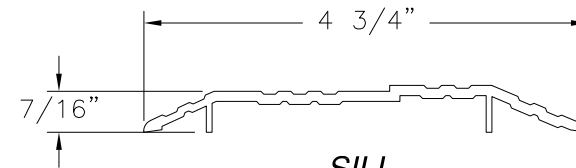

SILL
ALUMINUM 6063-T5 (TH250)

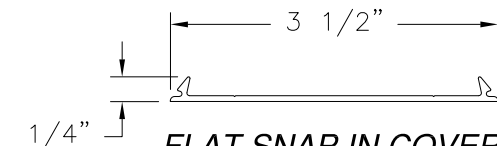

FLAT SNAP IN COVER
ALUMINUM 6063-T5 (PS100)

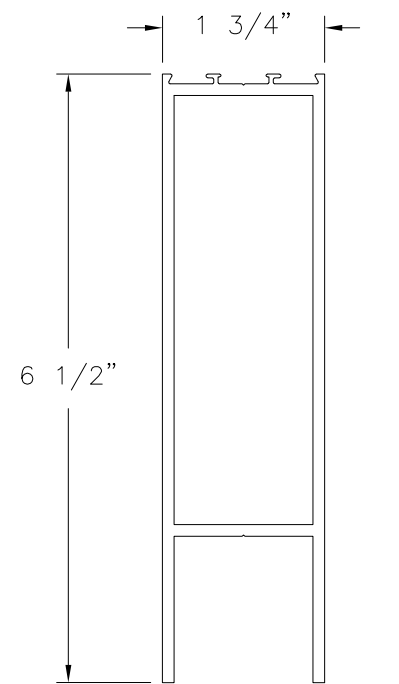

BOTTOM RAIL
ALUMINUM 6063-T5 (WS100)

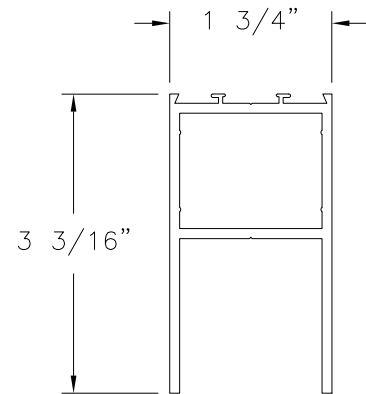

TOP RAIL
ALUMINUM 6063-T5 (D101)

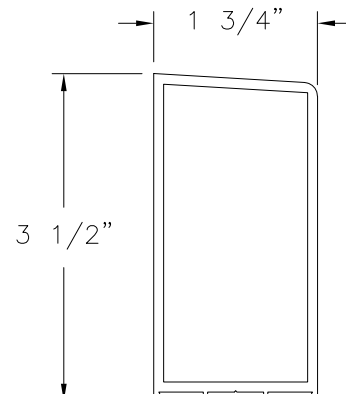

HINGE STILE
ALUMINUM 6063-T5 (MS500)

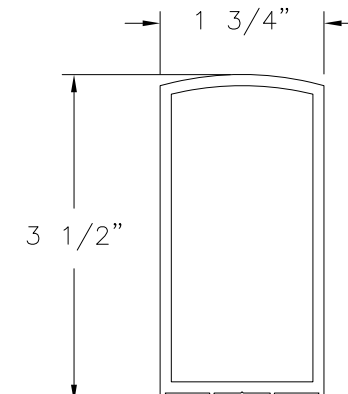

DOOR STILE
ALUMINUM 6063-T5 (MS400)

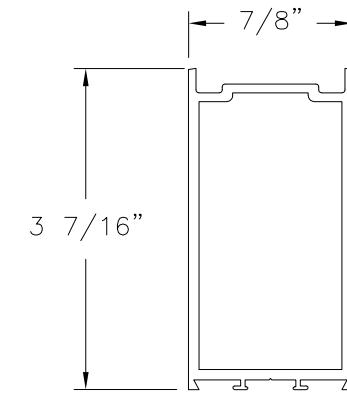

ADJUSTABLE ASTRAGAL STILE
ALUMINUM 6063-T5 (MS350/DN350)

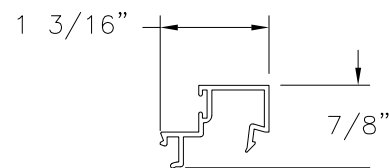

DOOR GLAZING STOP
ALUMINUM 6063-T5 (DS040)

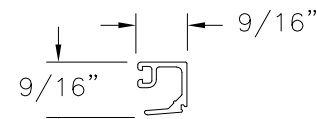

HIGH GLAZING STOP
ALUMINUM 6063-T5 (M-550)

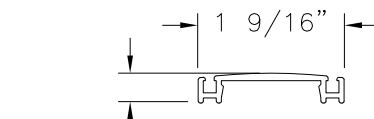

ADJUSTABLE ASTRAGAL
ALUMINUM 6063-T5 (DN350)

SIGNED: 03/29/2023

<p>US ALUMINUM 950 SOLON RD. WAXAHACHIE, TX 75165</p>		
<p>SERIES 400 ALUMINUM MEDIUM STILE DOOR 48" X 98" PANEL COMPONENTS</p>		
DRAWN: A.P.	DWG NO. 08-01801	REV B
SCALE NTS	DATE 10/01/12	SHEET 5 OF 5
<p>L. ROBERTO LOMAS P.E. 400 S. PALM AVE, INDIALANTIC, FL 32903 434-688-0609 rllomas@rlomaspe.com</p>		

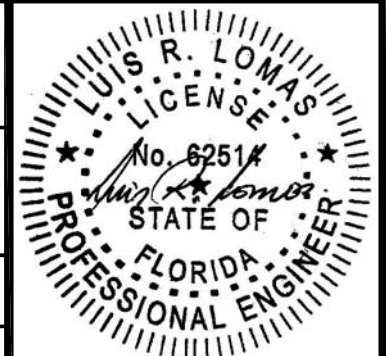

Luis R. Lomas P.E.
FL No.: 62514