

REVISIONS			
REV	DESCRIPTION	DATE	APPROVED
B	CHANGE MANUFACTURER'S NAME	03/28/2023	R.L.

NOTES:

1. THE PRODUCT SHOWN HEREIN IS DESIGNED AND MANUFACTURED TO COMPLY WITH REQUIREMENTS OF THE FLORIDA BUILDING CODE.
2. WOOD FRAMING AND MASONRY OPENING TO BE DESIGNED AND ANCHORED TO PROPERLY TRANSFER ALL LOADS TO STRUCTURE. FRAMING AND MASONRY OPENING IS THE RESPONSIBILITY OF THE ARCHITECT OR ENGINEER OF RECORD.
3. WHERE SHIM OR BUCK THICKNESS IS LESS THAN 1-1/2" UNITS MUST BE ANCHORED THROUGH THE FRAME IN ACCORDANCE WITH MANUFACTURER'S PUBLISHED INSTALLATION INSTRUCTIONS. ANCHORS SHALL BE SECURELY FASTENED DIRECTLY INTO MASONRY, CONCRETE OR OTHER STRUCTURAL SUBSTRATE MATERIAL.
4. WHERE WOOD BUCK THICKNESS IS 1-1/2" OR GREATER, BUCK SHALL BE SECURELY FASTENED TO MASONRY, CONCRETE OR OTHER STRUCTURAL SUBSTRATE. UNITS MAY BE ANCHORED THROUGH FRAME TO SECURED WOOD BUCK IN ACCORDANCE WITH MANUFACTURER'S PUBLISHED INSTALLATION INSTRUCTIONS.
5. WHERE 1X BUCK IS NOT USED DISSIMILAR MATERIALS MUST BE SEPARATED WITH APPROVED COATING OR MEMBRANE. SELECTION OF COATING OR MEMBRANE IS THE RESPONSIBILITY OF THE ARCHITECT OR ENGINEER OF RECORD.
6. BUCKS SHALL EXTEND BEYOND UNIT FRAME INTERIOR FACE SO THAT FULL FRAME SUPPORT IS PROVIDED.
7. SHIM AS REQUIRED AT EACH ANCHOR LOCATION WITH LOAD BEARING SHIM. SHIM WHERE SPACE OF 1/16" OR GREATER OCCURS. MAXIMUM ALLOWABLE SHIM STACK TO BE 1/2".
8. SHIMS SHALL BE LOCATED, APPLIED AND MADE FROM MATERIALS AND THICKNESS CAPABLE OF SUSTAINING APPLICABLE LOADS.
9. WIND LOAD DURATION FACTOR Cd=1.6 WAS USED FOR WOOD ANCHOR CALCULATIONS.
10. FRAME MATERIAL: EXTRUDED ALUMINUM 6063-T5.
11. UNITS MUST BE GLAZED PER ASTM E1300.
12. APPROVED IMPACT PROTECTIVE SYSTEM IS REQUIRED FOR THIS PRODUCT IN WIND BORNE DEBRIS REGIONS.
13. FOR ANCHORING THROUGH FRAME INTO WOOD FRAMING OR 2X BUCK USE #12 WOOD SCREWS WITH SUFFICIENT LENGTH TO ACHIEVE A 1 1/4" MINIMUM EMBEDMENT INTO SUBSTRATE. LOCATE ANCHORS AS SHOWN IN ELEVATIONS AND INSTALLATION DETAILS.

14. FOR ANCHORING THROUGH FRAME INTO MASONRY/CONCRETE USE 1/4" TAPCONS WITH SUFFICIENT LENGTH TO ACHIEVE A 1 1/4" MINIMUM EMBEDMENT INTO SUBSTRATE WITH 2" MINIMUM EDGE DISTANCE. LOCATE ANCHORS AS SHOWN IN ELEVATIONS AND INSTALLATION DETAILS.
15. FOR ANCHORING THROUGH FRAME INTO METAL STRUCTURE USE #12 SMS OR SELF DRILLING SCREWS WITH SUFFICIENT LENGTH TO ACHIEVE 3 THREADS MINIMUM BEYOND STRUCTURE INTERIOR WALL. LOCATE ANCHORS AS SHOWN IN ELEVATIONS AND INSTALLATION DETAILS.
16. ALL FASTENERS TO BE CORROSION RESISTANT.
17. INSTALLATION ANCHORS SHALL BE INSTALLED IN ACCORDANCE WITH ANCHOR MANUFACTURER'S INSTALLATION INSTRUCTIONS AND ANCHORS SHALL NOT BE USED IN SUBSTRATES WITH STRENGTHS LESS THAN THE MINIMUM STRENGTH SPECIFIED BELOW:
  - A. WOOD: MINIMUM SPECIFIC GRAVITY OF G=0.42
  - B. CONCRETE: MINIMUM COMPRESSIVE STRENGTH OF 2,000 PSI.
  - C. MASONRY: HOLLOW/FILLED BLOCK PER ASTM C90 WITH Fm=2,000PSI MINIMUM.
  - D. METAL STRUCTURE: STEEL 18GA (.048") FY=33KSI/FU=52KSI OR ALUMINUM 6063-T5 FU=30KSI 1/8" THICK MINIMUM

TABLE OF CONTENTS	
SHEET NO.	DESCRIPTION
1	NOTES
2	ELEVATIONS
3 - 4	INSTALLATION DETAILS
5	COMPONENTS

<b>US ALUMINUM</b> 950 SOLON RD. WAXAHACHIE, TX 75165		
SERIES 250 ALUMINUM DOOR NON-IMPACT NOTES		
DRAWN: A.P.	DWG NO. 08-01828	REV B
SCALE NTS	DATE 10/22/12	SHEET 1 OF 5
L. ROBERTO LOMAS P.E. 400 S. PALM AVE, INDIALANTIC, FL 32903 434-688-0609 rllomas@rlomaspe.com		

SIGNED: 03/28/2023

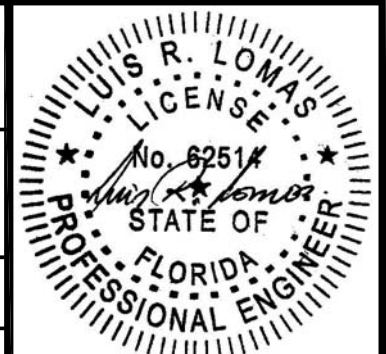

Luis R. Lomas P.E.  
FL No.: 62514

REVISIONS			
REV	DESCRIPTION	DATE	APPROVED
B	CHANGE MANUFACTURER'S NAME	03/28/2023	R.L.

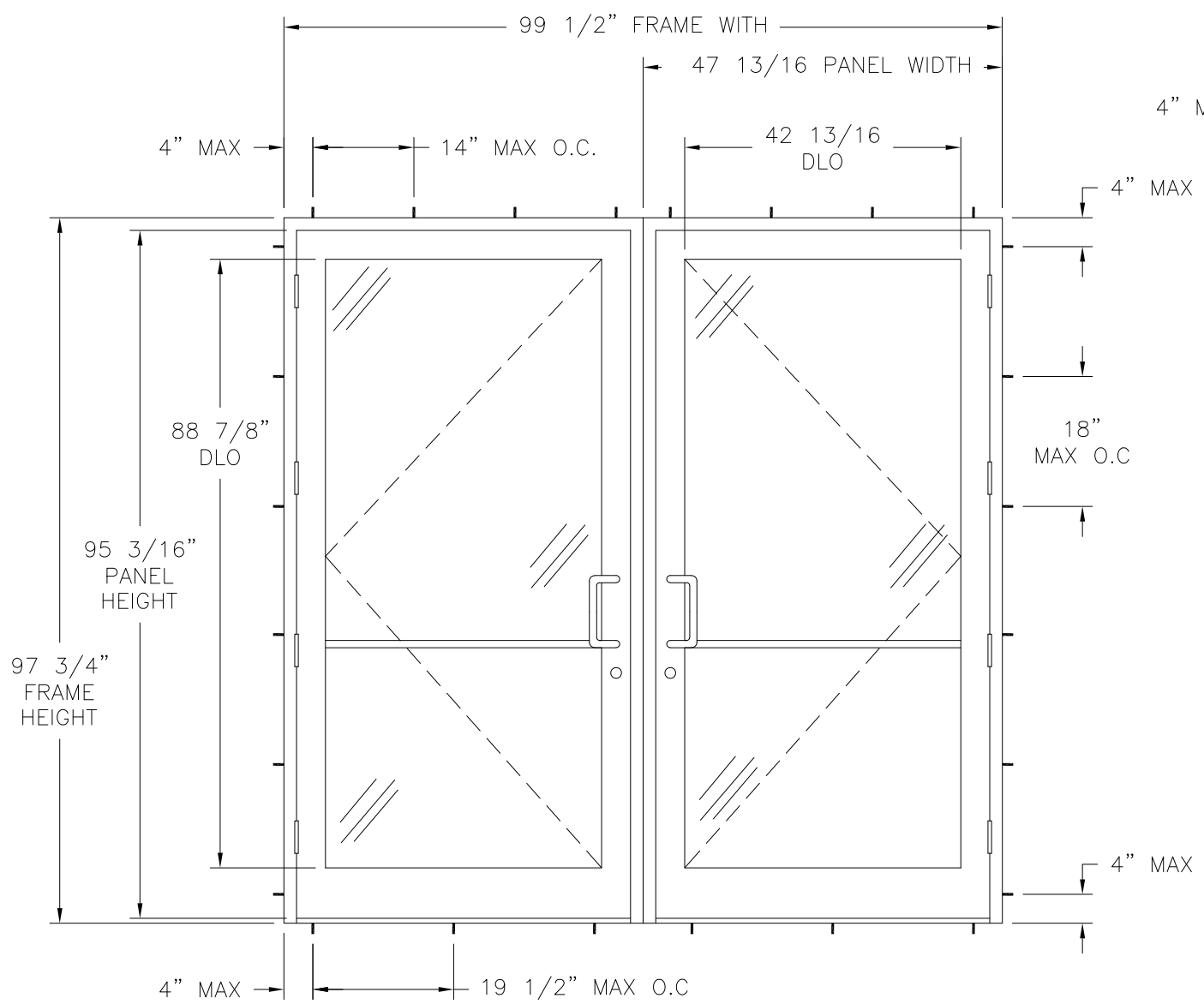

**SERIES 250 ALUMINUM DOUBLE DOOR**  
EXTERIOR VIEW

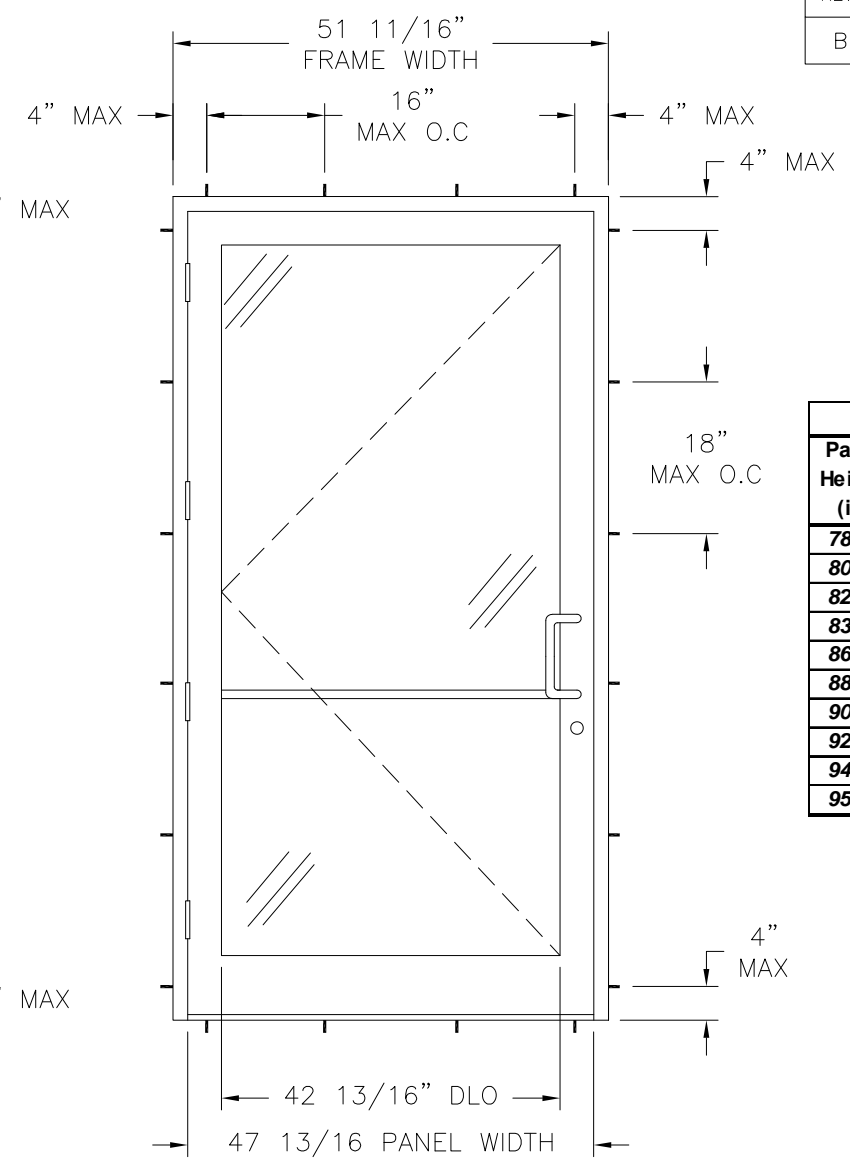

**SERIES 250 ALUMINUM SINGLE DOOR**  
EXTERIOR VIEW

Design pressure rating (psf)										
Panel Height (in)	Panel width (in)									
	24.81		30.81		35.81		42.81		47.81	
	Pos	Neg	Pos	Neg	Pos	Neg	Pos	Neg	Pos	Neg
78.19	44.9	44.9	40.7	40.7	37.5	37.5	33.7	33.7	31.4	31.4
80.19	44.2	44.2	39.8	39.8	36.5	36.5	32.5	32.5	30.1	30.1
82.19	43.5	43.5	38.9	38.9	35.5	35.5	31.3	31.3	28.7	28.7
83.19	43.2	43.2	38.5	38.5	35.0	35.0	30.7	30.7	28.0	28.0
86.19	42.1	42.1	37.2	37.2	33.5	33.5	28.9	28.9	26.0	26.0
88.19	41.4	41.4	36.3	36.3	32.5	32.5	27.7	27.7	24.7	24.7
90.19	40.7	40.7	35.5	35.5	31.5	31.5	26.5	26.5	23.4	23.4
92.19	40.0	40.0	34.6	34.6	30.5	30.5	25.3	25.3	22.0	22.0
94.19	39.3	39.3	33.7	33.7	29.5	29.5	24.1	24.1	20.7	20.7
95.19	39.0	39.0	33.3	33.3	29.0	29.0	23.5	23.5	20.0	20.0

DESIGN PRESSURE RATING	IMPACT RATING
±20.0PSF	NONE
THIS SYSTEM WAS NOT TESTED FOR WATER INFILTRATION AND IS TO BE INSTALLED ONLY WHERE THE WATER REQUIREMENT IS NOT NEEDED	

OTHER SIZES APPROVED, SEE CHART #1 THIS SHEET

SIGNED: 03/28/2023

HARDWARE SCHEDULE
A. PR-032 PULL HANDLE
B. PR-034 PUSH BAR
C. DH-129 HOOK BOLT LOCK
D. (4) DH-009 FIVE BARREL STAINLES STEEL HINGE
E. DM008 FLUSH BOLT (TOP & BOTTOM INACTIVE PANEL)

US ALUMINUM  
950 SOLON RD.  
WAXAHACHIE, TX 75165

SERIES 250 ALUMINUM DOOR  
NON-IMPACT  
ELEVATIONS

DRAWN: A.P.	DWG NO. 08-01828	REV B
SCALE NTS	DATE 10/22/12	SHEET 2 OF 5

L. ROBERTO LOMAS P.E.  
400 S. PALM AVE, INDIALANTIC, FL 32903  
434-688-0609 rllomas@rlomaspe.com

Luis R. Lomas P.E.  
FL No.: 62514

REVISIONS			
REV	DESCRIPTION	DATE	APPROVED
B	CHANGE MANUFACTURER'S NAME	03/28/2023	R.L.

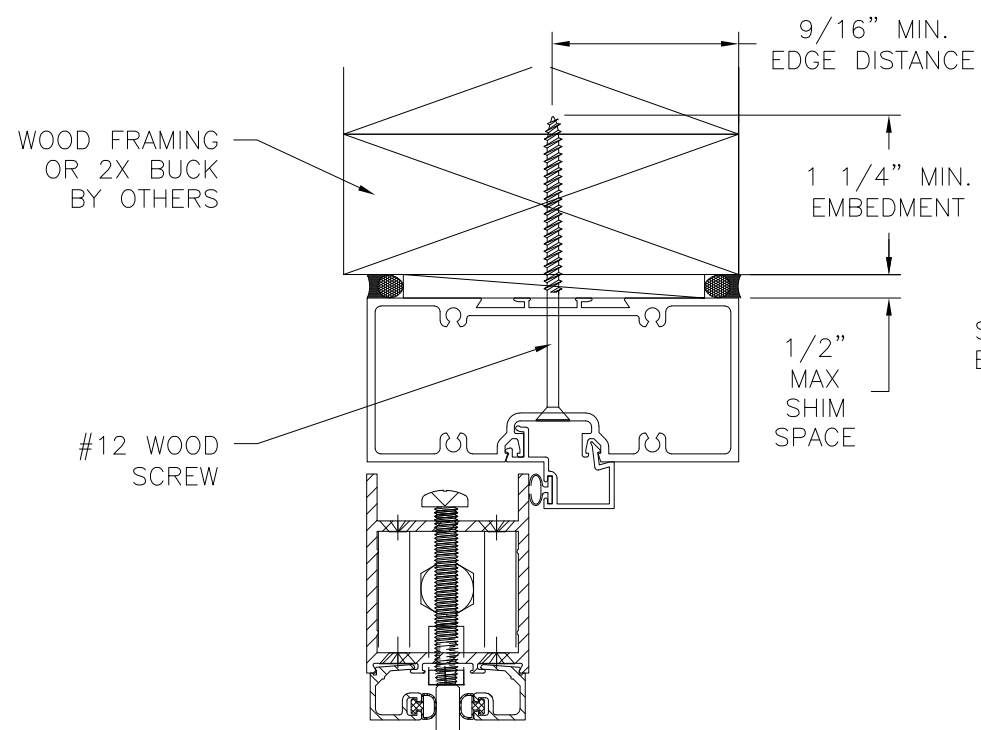

EXTERIOR INTERIOR

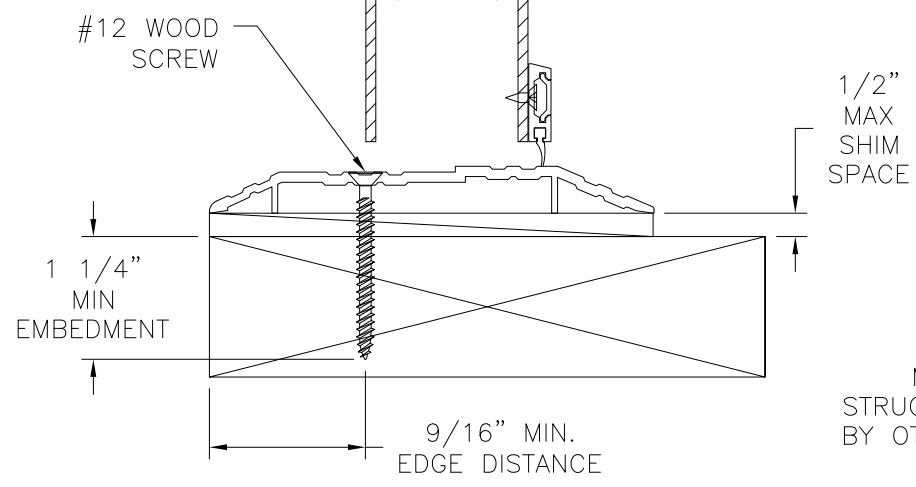

VERTICAL CROSS SECTION  
WOOD FRAMING OR 2X BUCK INSTALLATION

NOTES:  
 1. INTERIOR AND EXTERIOR FINISHES, BY OTHERS, NOT SHOWN FOR CLARITY.  
 2. PERIMETER AND JOINT SEALANT BY OTHERS TO BE DESIGNED IN ACCORDANCE WITH ASTM E2112

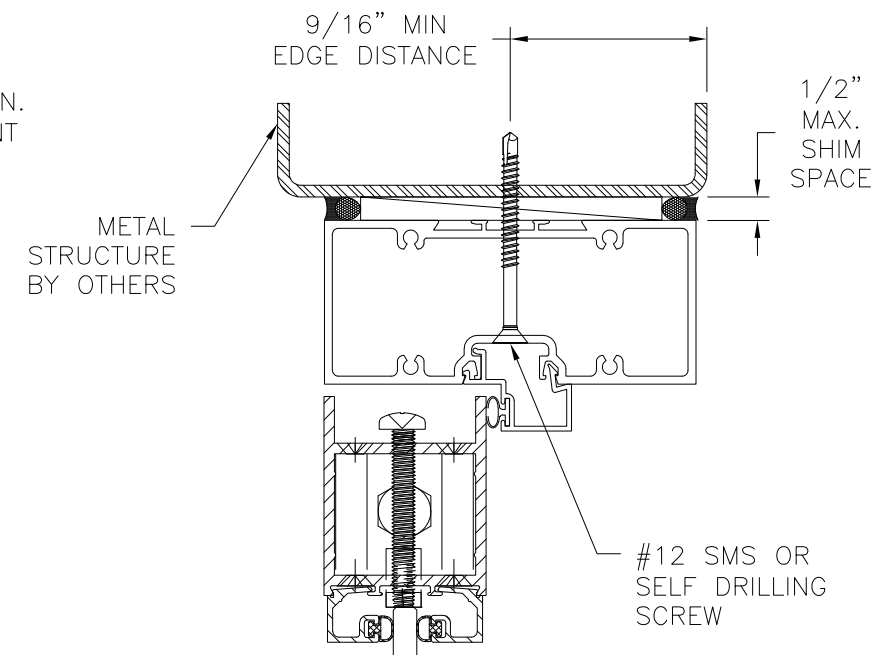

EXTERIOR INTERIOR

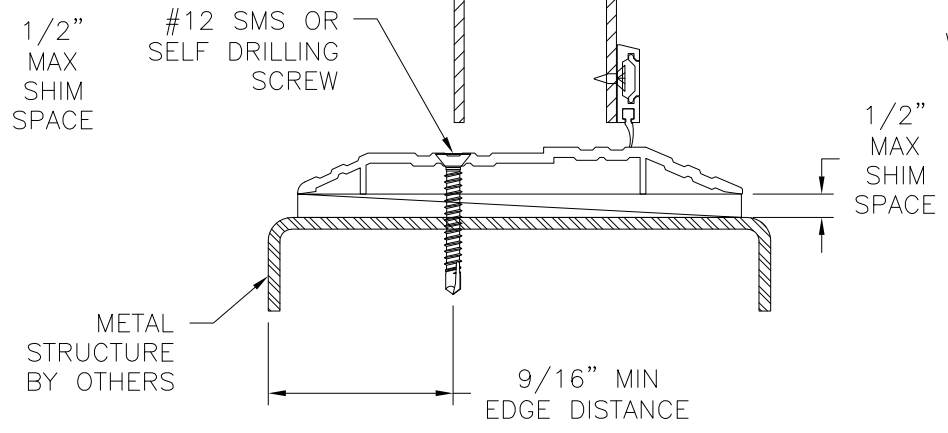

VERTICAL CROSS SECTION  
METAL STRUCTURE INSTALLATION

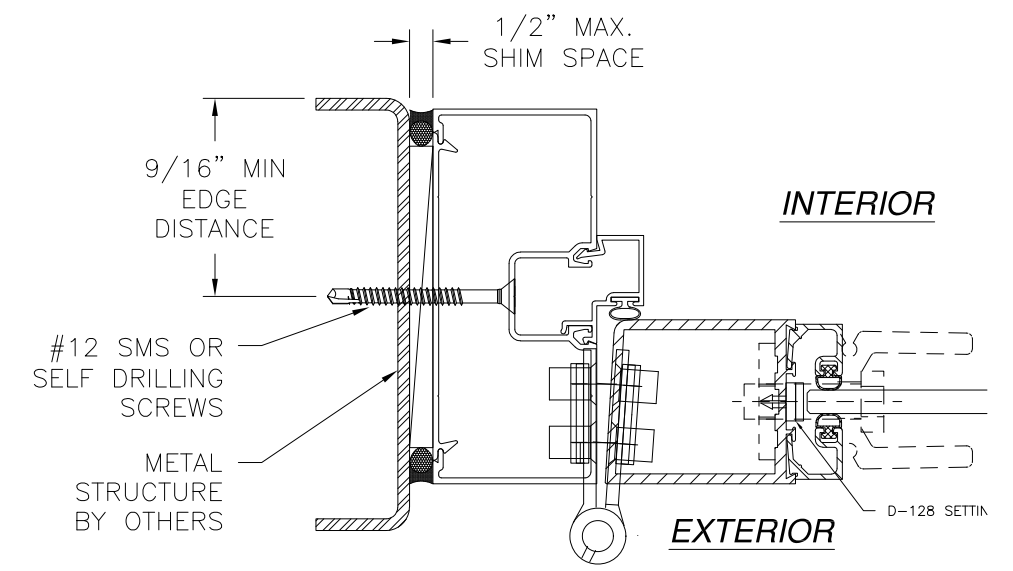

JAMB INSTALLATION DETAIL  
METAL STRUCTURE INSTALLATION

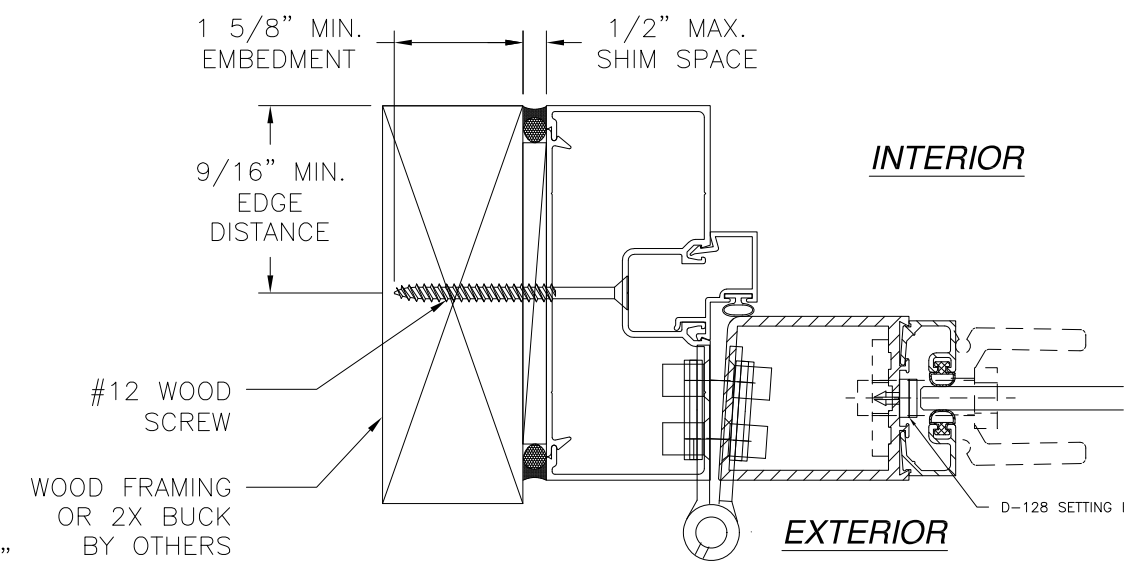

JAMB INSTALLATION DETAIL  
WOOD FRAMING OR 2X BUCK INSTALLATION

SIGNED: 03/28/2023

US ALUMINUM  
 950 SOLON RD.  
 WAXAHACHIE, TX 75165

SERIES 250 ALUMINUM DOOR  
 NON-IMPACT  
 INSTALLATION DETAILS

DRAWN: A.P.	DWG NO. 08-01828	REV B
SCALE NTS	DATE 10/22/12	SHEET 3 OF 5

L. ROBERTO LOMAS P.E.  
 400 S. PALM AVE, INDIALANTIC, FL 32903  
 434-688-0609 rllomas@rlomaspe.com

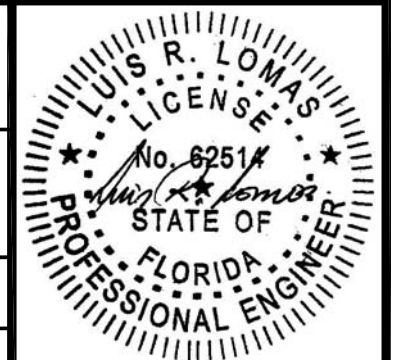

Luis R. Lomas P.E.  
 FL No.: 62514

REVISIONS			
REV	DESCRIPTION	DATE	APPROVED
B	CHANGE MANUFACTURER'S NAME	03/28/2023	R.L.

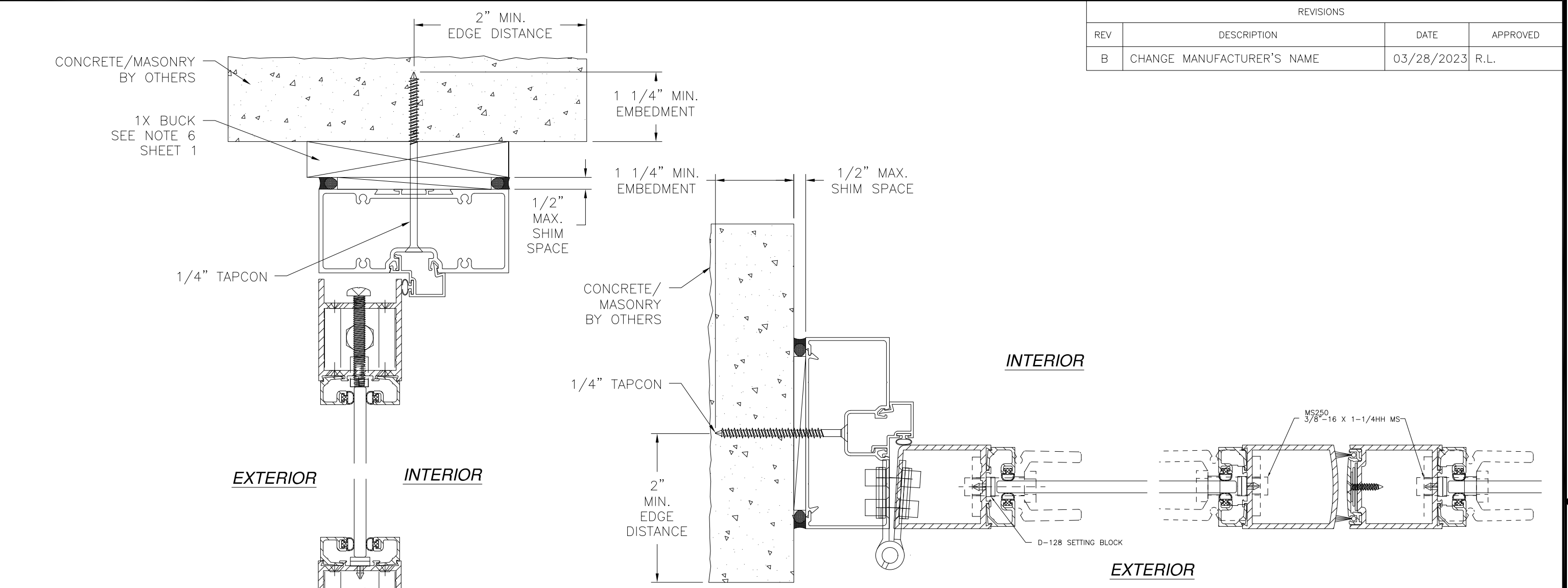

**JAMB INSTALLATION DETAIL**  
 CONCRETE/MASONRY WITHOUT 1X BUCK INSTALLATION  
 FOR CONCRETE/MASONRY INSTALLATION WITH 1X BUCK REFER  
 TO HEAD AND SILL INSTALLATION DETAILS

- NOTES:**
1. INTERIOR AND EXTERIOR FINISHES, BY OTHERS, NOT SHOWN FOR CLARITY.
  2. PERIMETER AND JOINT SEALANT BY OTHERS TO BE DESIGNED IN ACCORDANCE WITH ASTM E2112

SIGNED: 03/28/2023

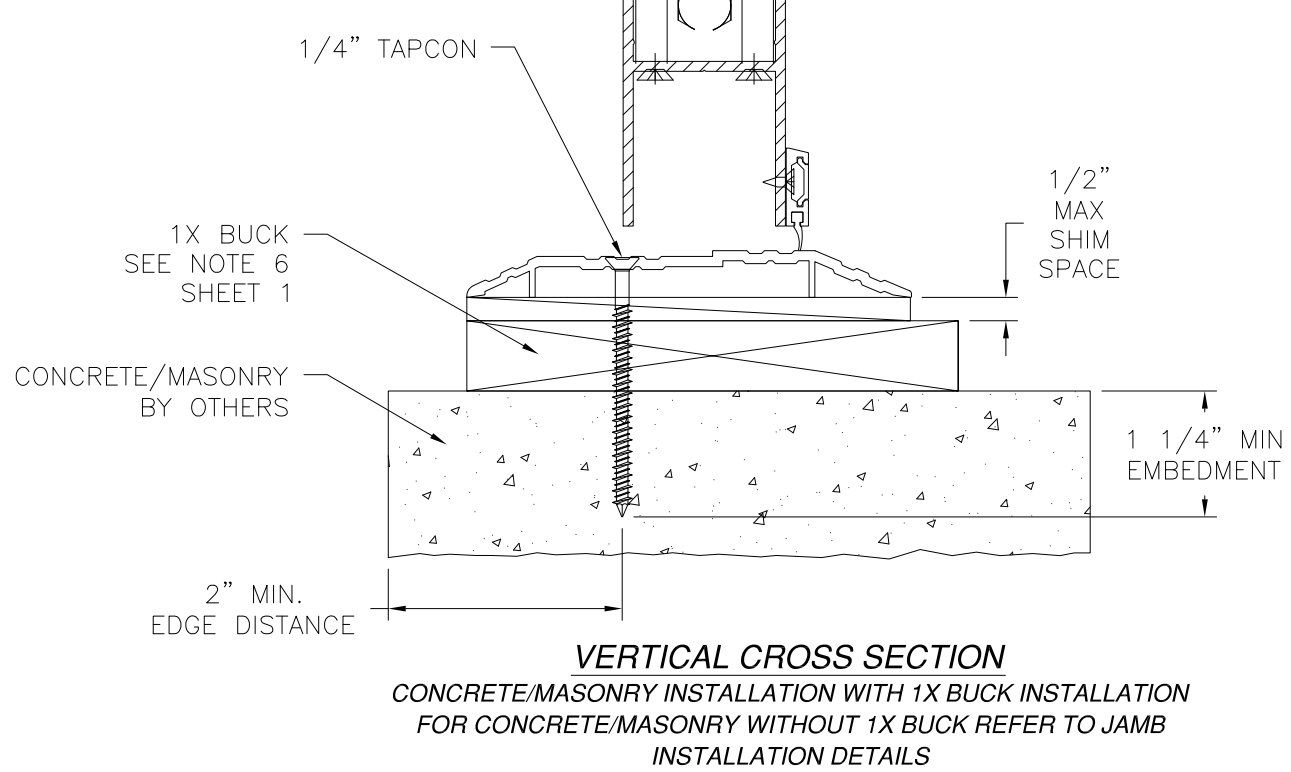

**VERTICAL CROSS SECTION**  
 CONCRETE/MASONRY INSTALLATION WITH 1X BUCK INSTALLATION  
 FOR CONCRETE/MASONRY WITHOUT 1X BUCK REFER TO JAMB  
 INSTALLATION DETAILS

<b>US ALUMINUM</b> 950 SOLON RD. WAXAHACHIE, TX 75165		
SERIES 250 ALUMINUM DOOR NON-IMPACT INSTALLATION DETAILS		
DRAWN: A.P.	DWG NO. 08-01828	REV B
SCALE NTS	DATE 10/22/12	SHEET 4 OF 5
L. ROBERTO LOMAS P.E. 400 S. PALM AVE, INDIALANTIC, FL 32903 434-688-0609 rllomas@rlomaspe.com		

Luis R. Lomas P.E.  
 FL No.: 62514

REVISIONS			
REV	DESCRIPTION	DATE	APPROVED
B	CHANGE MANUFACTURER'S NAME	03/28/2023	R.L.

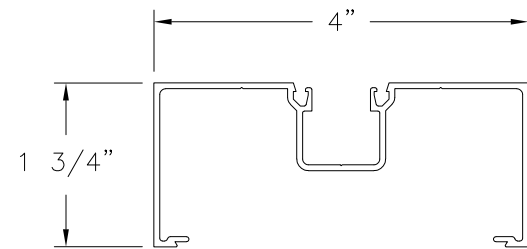

**JAMB**  
ALUMINUM 6063-T5 (J-402)

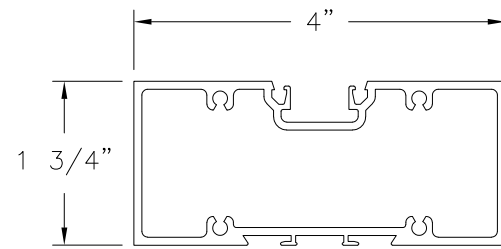

**HEAD**  
ALUMINUM 6063-T5 (JS417)

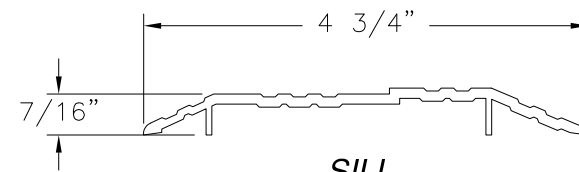

**SILL**  
ALUMINUM 6063-T5 (TH250)

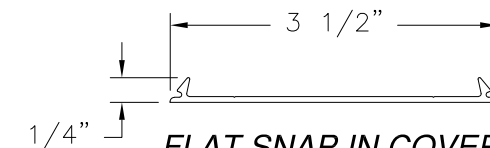

**FLAT SNAP IN COVER**  
ALUMINUM 6063-T5 (PS100)

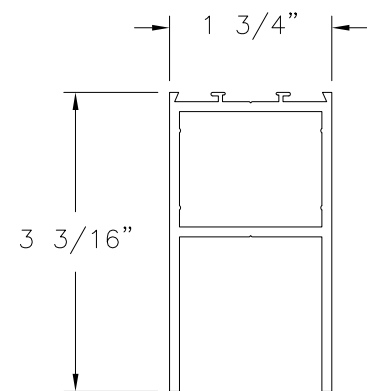

**BOTTOM RAIL**  
ALUMINUM 6063-T5 (D-101)

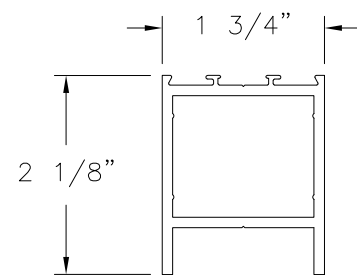

**TOP RAIL**  
ALUMINUM 6063-T5 (D-201)

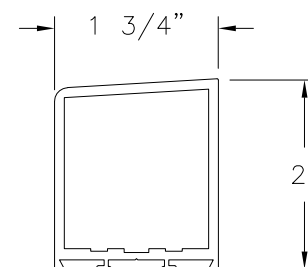

**HINGE STILE**  
ALUMINUM 6063-T5 (DT550)

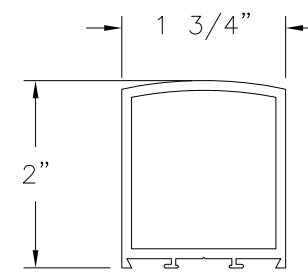

**DOOR STILE**  
ALUMINUM 6063-T5 (DT400)

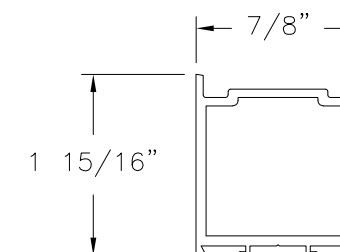

**ADJUSTABLE ASTRAGAL STILE**  
ALUMINUM 6063-T5 (DA350)

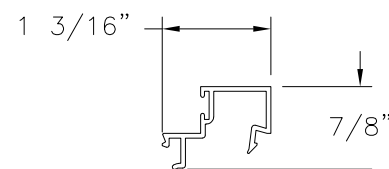

**DOOR GLAZING STOP**  
ALUMINUM 6063-T5 (DS041TL)

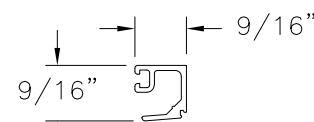

**HIGH GLAZING STOP**  
ALUMINUM 6063-T5 (M-550)

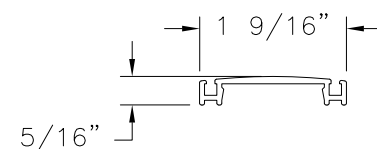

**ADJUSTABLE ASTRAGAL**  
ALUMINUM 6063-T5 (DN350)

SIGNED: 03/28/2023

<b>US ALUMINUM</b> 950 SOLON RD. WAXAHACHIE, TX 75165		
SERIES 250 ALUMINUM DOOR NON-IMPACT COMPONENTS		
DRAWN: A.P.	DWG NO. 08-01828	REV B
SCALE NTS	DATE 10/22/12	SHEET 5 OF 5
L. ROBERTO LOMAS P.E. 400 S. PALM AVE, INDIALANTIC, FL 32903 434-688-0609 rllomas@rlomaspe.com		

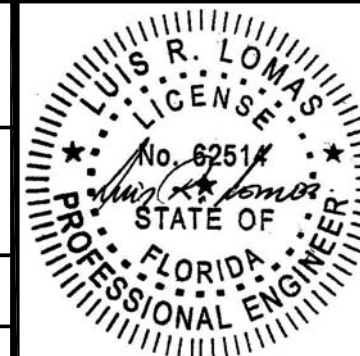

Luis R. Lomas P.E.  
FL No.: 62514