

PLY GEM WINDOWS SERIES 1500 SINGLE HUNG WINDOW

(NON-IMPACT)

NOTES:

- THIS INSTALLATION HAS BEEN EVALUATED FOR USE IN LOCATIONS ADHERING TO THE FLORIDA BUILDING CODE OUTSIDE THE HVHZ, AND WHERE PRESSURE REQUIREMENTS AS DETERMINED BY ASCE 7 MINIMUM DESIGN LOADS FOR BUILDINGS AND OTHER STRUCTURES DO NOT EXCEED THE DESIGN PRESSURE RATINGS HEREIN.
- WHEN USED IN AREAS REQUIRING IMPACT PROTECTION, THIS PRODUCT REQUIRES THE USE OF APPROVED IMPACT PROTECTIVE DEVICES (SHUTTERS).
- ANCHOR TYPE, SIZE, SPACING, EMBEDMENT, AND EDGE DISTANCE SHALL BE AS SPECIFIED IN THESE DRAWINGS. USE APPROPRIATE ANCHORAGE FROM TABLE I ACCORDING TO SUBSTRATE TYPE. A MINIMUM CENTER-TO-CENTER SPACING OF 3" SHALL BE MAINTAINED BETWEEN ALL INSTALLATION FASTENERS IN ANY DIRECTION.
- ANCHOR EMBEDMENT TO SUBSTRATE SHALL BE BEYOND WALL DRESSING OR STUCCO. FOR MASONRY OPENINGS WITH WOOD BUCKS LESS THAN 1-1/2" THICK, EMBEDMENT SHALL BE BEYOND WOOD BUCKS, IF USED, AND INTO MASONRY SUBSTRATE. WOOD BUCKS WITH MASONRY ARE OPTIONAL.
- WOOD, METAL, OR MASONRY OPENINGS, BUCKS, AND BUCK FASTENERS, BY OTHERS, SHALL BE PROPERLY DESIGNED AND INSTALLED BY OTHERS TO TRANSFER SUPERIMPOSED LOADS TO THE STRUCTURE. ADEQUACY OF THE STRUCTURE TO RECEIVED THESE LOADS SHALL BE VERIFIED BY THE CONTRACTOR OR AUTHORITY HAVING JURISDICTION (AHJ).
- IT IS THE RESPONSIBILITY OF THE ARCHITECT OR ENGINEER OF RECORD OR AS APPROVED BY THE AHJ TO SELECT PLY GEM PRODUCTS TO MEET ALL APPLICABLE LOCAL LAWS, BUILDING CODES, ORDINANCES, OR OTHER SAFETY REQUIREMENTS FOR EACH INSTALLATION.
- SHIMS ARE REQUIRED WHERE GAPS OF GREATER THAN 1/16" EXIST BETWEEN OPENING AND FRAME. MAX. SHIM STACK IS 1/4". SHIMS SHALL BE LOAD-BEARING AND CAPABLE OF TRANSFERRING LOADS TO THE SUBSTRATE.
- SEALING AND FLASHING STRATEGIES FOR OVERALL WATER INFILTRATION RESISTANCE OF THE INSTALLED PRODUCT SHALL BE THE RESPONSIBILITY OF OTHERS USING ASTM E 2112 AND IS NOT ADDRESSED BY THIS DOCUMENT.
- INSTALLED GLAZING SHALL COMPLY WITH ASTM E 1300.
- ALL FASTENERS PENETRATING INTO PRESSURE TREATED WOOD SHALL BE CAPABLE OF PREVENTING CORROSION DUE TO REACTION WITH PRESSURE TREATMENT CHEMICALS. ANY DISSIMILAR MATERIALS THAT COME INTO CONTACT SHALL BE PROTECTED TO PREVENT REACTIONS IN ACCORDANCE WITH CODE REQUIREMENTS.
- A WIND LOAD DURATION FACTOR $C_d = 1.6$ WAS USED FOR THE ANALYSIS OF WOOD SCREWS ONLY.
- PRODUCTS SHALL BE CONSTRUCTED AS SPECIFIED IN TEST REPORTS NATIONAL CERTIFIED TESTING LABORATORIES I10-15596-1 & -2, I10-15597-1, I10-15598-1, I10-15599-1 & -2, I10-15600-1, I10-1601-1, I10-15602-1, I10-15605-1, I10-16027-1, I10-16028-1, I10-16245-1, I10-19262-1, I10-19348-1 THRU -5, I10-19792-1, I10-20228-1 & I10-20318-1.
- DESIGNATION "X" IS FOR OPERABLE PANEL AND "O" IS FOR FIXED PANEL.
- USE A BACKER ROD ON ALL JOINTS >3/4" DEEP AND/OR WIDER THAN 1/4". FINISHED CAULK JOINT SHOULD BE A MINIMUM OF 3/8" DEEP.

SIZE CHART				
OVERALL SIZE		PRODUCT RATING	MAX. DESIGN PRESSURE	GLAZING TYPE / CONFIG.
WIDTH	HEIGHT			
52-1/8"	62"	LC-PG50	+50/-50 PSF	TYPE G1 EVEN SASH
53"	77-1/8"	LC-PG40	+40/-40 PSF	
35-15/16"	84"	LC-PG50	+50/-50 PSF	TYPE G1 OR G2 / EVEN SASH
40"	72"	LC-PG50	+50/-50 PSF	
48"	72"	LC-PG50	+50/-50 PSF	
44"	77-1/8"	LC-PG40	+40/-40 PSF	
35-15/16"	73 15/16"	LC-PG35	+35/-35 PSF	
35-15/16"	73 15/16"	LC-PG50	+50/-50 PSF	
35-1/2"	61-1/2"	LC-PG50	+55/-55 PSF	TYPE G1 OR G2 / ORIEL SASH
47-1/2"	59-1/2"	LC-PG50	+50/-50 PSF	
48-1/16"	95-15/16"	LC-PG30	+30/-35 PSF	
48-1/16"	95-15/16"	LC-PG25	+25/-30 PSF	
35-1/2"	77"	LC-PG35	+35/-35 PSF	
35-1/2"	77"	LC-PG50	+50/-50 PSF	
44-1/16"	77-1/8"	LC-PG40	+40/-40 PSF	TYPE G2 / EVEN SASH
36-1/16"	74-1/16"	LC-PG50	+50/-50 PSF	
35-7/16"	73-1/2"	LC-PG35	+35/-35 PSF	TYPE G3 / EVEN SASH
35-15/16"	61 15/16"	LC-PG35	+35/-35 PSF	
35-1/2"	73-1/2"	LC-PG30	+30/-30 PSF	
40-1/16"	72"	LC-PG25	+35/-35 PSF	
43-15/16"	77-1/8"	LC-PG25	+25/-25 PSF	TYPE G4 / EVEN SASH
53"	77-1/8"	LC-PG50	+50/-50 PSF	

TABLE OF CONTENTS	
SHEET	SHEET DESCRIPTION
1	INSTALLATION & GENERAL NOTES
2	ELEVATIONS & ANCHOR SCHEDULE
3	VERTICAL SECTIONS
4	HORIZONTAL SECTIONS
5	GLAZING DETAILS

TABLE I: INSTALLATION FASTENERS TABLE

ID	SUBSTRATE TYPE	ANCHOR TYPE	MIN. EMBED.	MIN. EDGE DISTANCE
FIN INSTALLATION				
A	2X MIN. SPRUCE-PINE-FIR WOOD (G=0.42)	#8 WOOD SCREW	1-1/2"	7/16"
B	16 GAUGE (0.060") STEEL 36 KSI MIN. OR 1/8" ALUM. 6063-T5 MIN.	#10-16 SELF-DRILLING SCREW (TEKS/DRIL-FLEX/KWIK-FLEX)	FULL, PLUS 3 THREADS MIN.	7/16"
FRAME OR CLIP INSTALLATION				
C	CONCRETE (2 KSI MIN.)	3/16" ITW TAPCON	1-1/2"	1-1/8"
D	HOLLOW OR GROUT-FILLED CMU (117 PCF MIN.)	3/16" ITW TAPCON	1"	2"
E	2X MIN. SOUTHERN PINE WOOD (G=0.55)	3/16" ITW TAPCON	1-3/8"	7/8"
F	CONCRETE (2.85 KSI MIN.)	3/16" ELCO ULTRACON	1-3/4"	1-1/8"
G	HOLLOW OR GROUT-FILLED CMU (ASTM C-90)	3/16" ELCO ULTRACON	1-1/4"	2-1/2"
H	2X MIN. SOUTHERN PINE WOOD (G=0.55)	#10 WOOD SCREW	1-3/8"	7/8"
I	16 GAUGE (0.060") STEEL 36 KSI MIN. OR 1/8" ALUM. 6063-T5 MIN.	#10-16 SELF-DRILLING SCREW (TEKS/DRIL-FLEX/KWIK-FLEX)	FULL, PLUS 3 THREADS MIN.	1/2"

NOTE: ALL SCREWS AND TAPCONS SHALL HAVE MOD. TRUSS, PAN, OR HEX WASHER HEAD, 0.42" MIN. HEAD OR WASHER DIAMETER FOR FIN ANCHORS, 0.355" MIN. HEAD OR WASHER DIAMETER FOR FRAME ANCHORS.

TITLE: SERIES 1500 SINGLE HUNG WINDOW INSTALLATION AND GENERAL NOTES	DATE	07.02.18	10.17.18	12.01.20	12.04.23
	BY	LMH	LMH	LMH	LMH
	REVISION DESCRIPTION	REVISED PER EC 07-008 & N18-001, W-1867			
	NO.	E	F	G	H
DATE:	9.18.13	DWN BY:	MSS	CHK BY:	SCALE:
					NTS

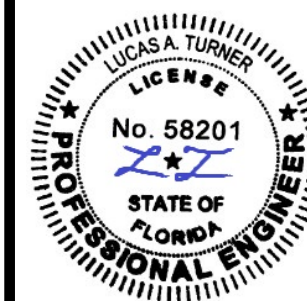

12/04/2023
LUCAS A. TURNER, P.E.
FL PE # 58201
TURNER ENGINEERING &
CONSULTING, INC.
(COA # 29779)
2428 OLD NATCHEZ TRACE
TRAIL, CAMDEN, TN 38320
PH. 941-380-1574

FL#: **16103**

DWG #: **PGWI8IFL**

SHEET: **1-FL OF 5**

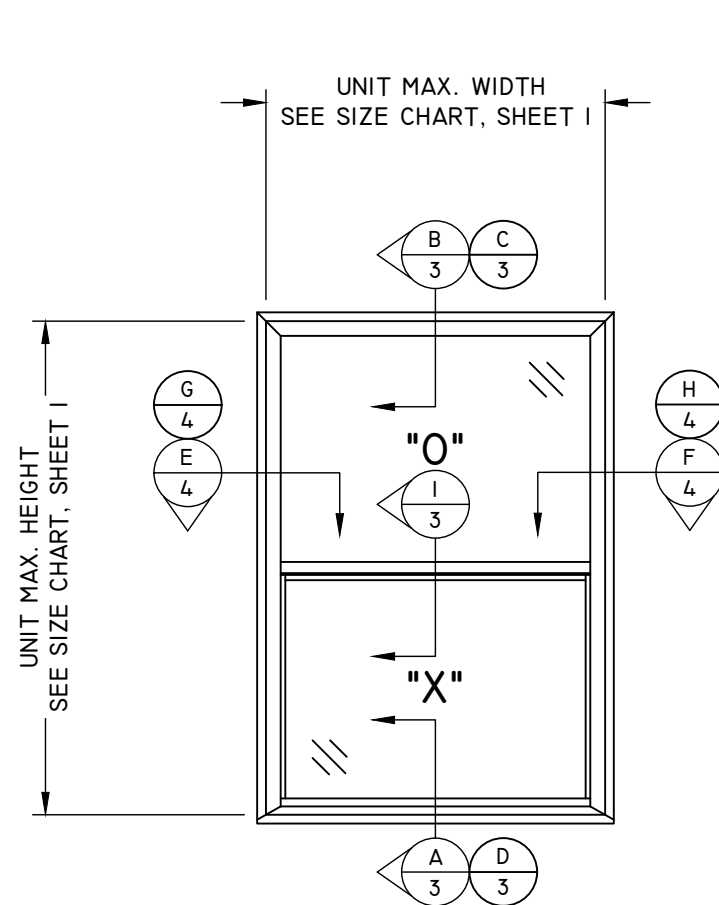

TYPICAL ELEVATION

EVEN SASH

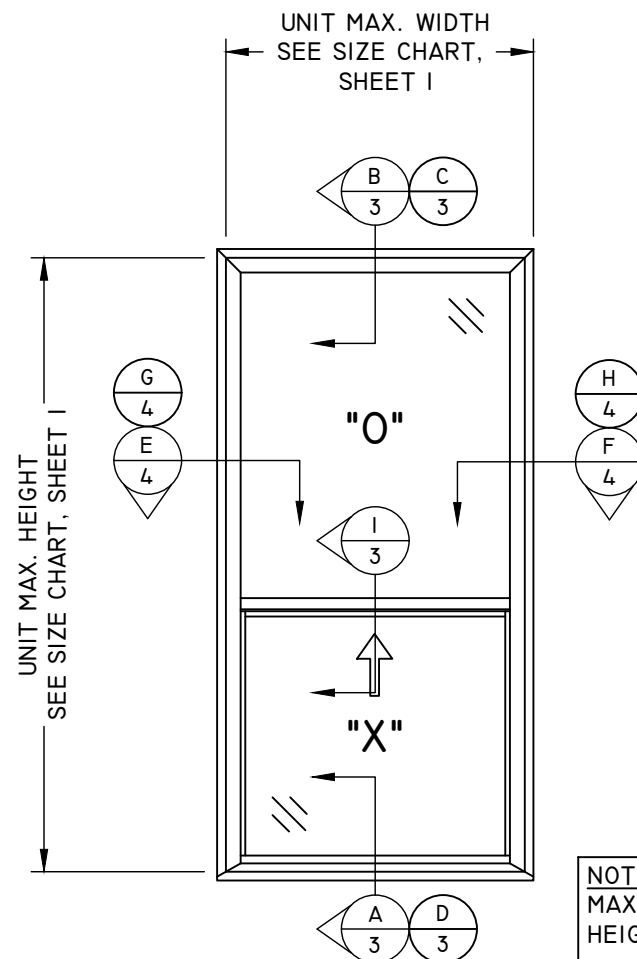

TYPICAL ELEVATION

ORIEL SASH

NOTE:
MAXIMUM ORIEL UNIT FIXED D.L.O.
HEIGHT IS LIMITED TO 50'-7/8".

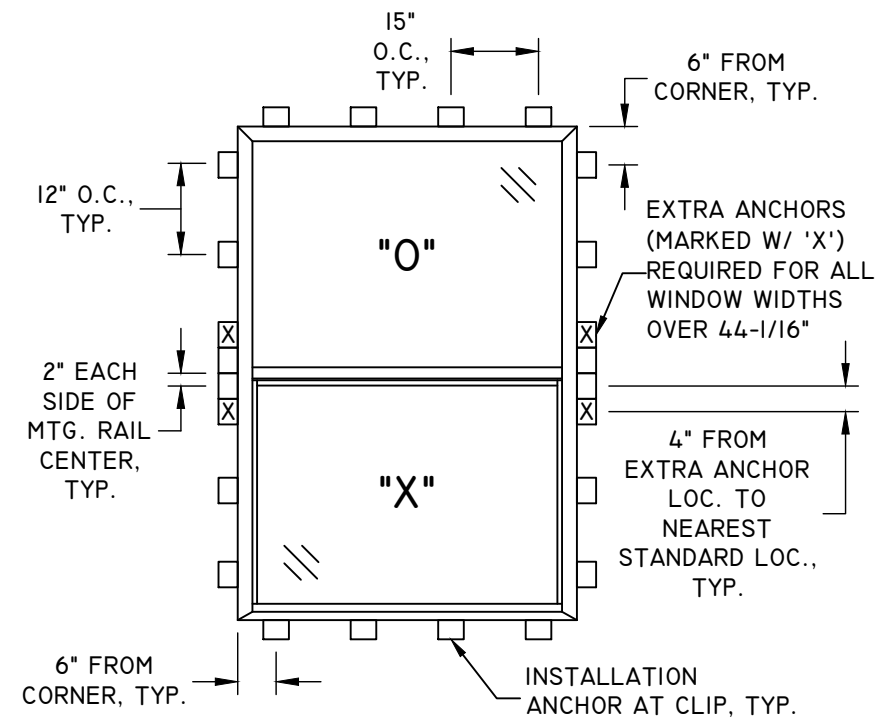

ANCHOR LAYOUT

CLIP INSTALLATION

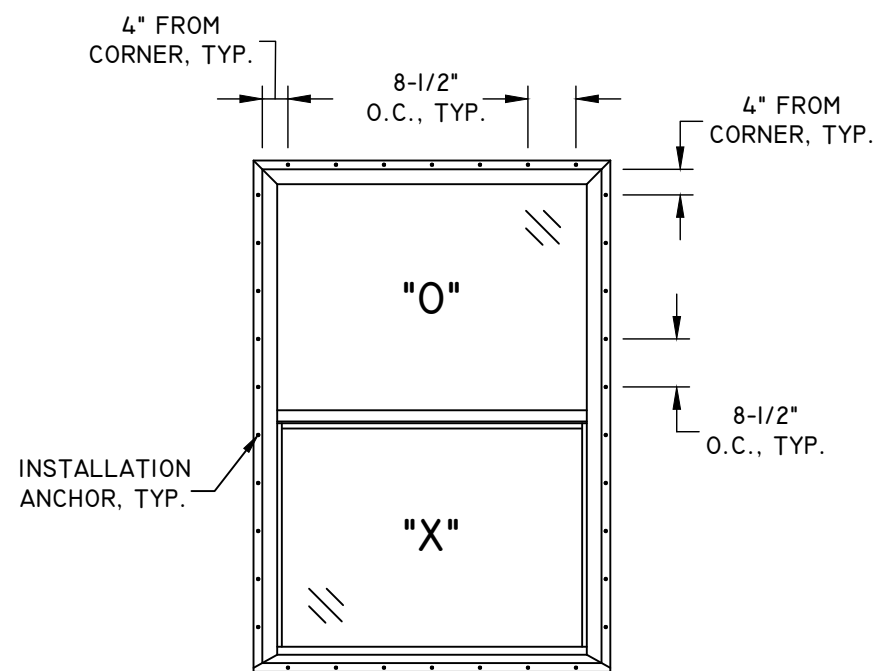

ANCHOR LAYOUT

FIN INSTALLATION
TABLE I, SHEET I
FASTENER ID "A" & "B" ONLY

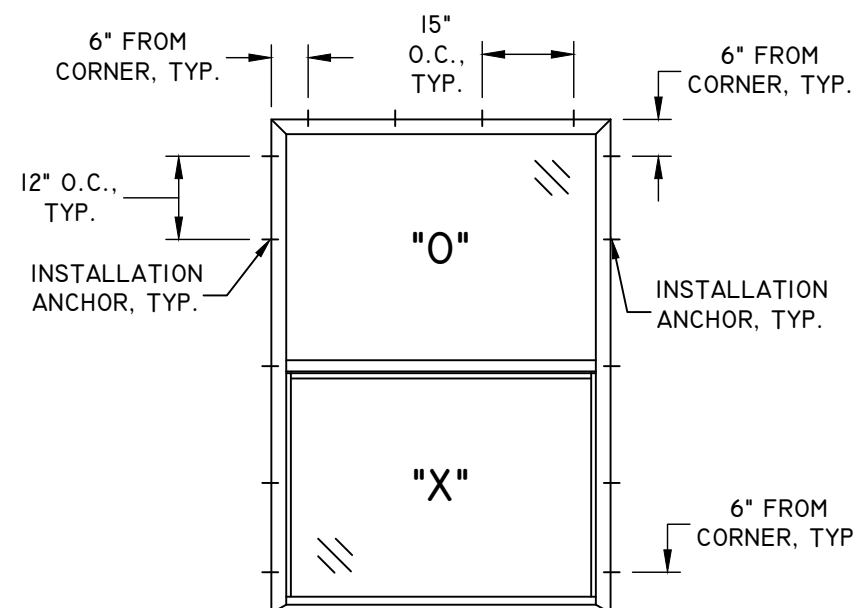

ANCHOR LAYOUT

FRAME INSTALLATION
TABLE I, SHEET I
FASTENER ID "C"- "D"- "E"- "F"- "G"- "H" & "I"

TITLE: SERIES 1500 SINGLE HUNG WINDOW ELEVATIONS & ANCHOR SCHEDULE		DATE	BY
NO.	REVISION DESCRIPTION	07.02.18	LMH
E	UPDATED PER EC 07-008 & N18-001, W-1867	10.17.18	LMH
F	UPDATED FRAME ANCHOR LAYOUT.	12.01.20	LMH
G	7TH EDITION 2020 FBC	12.04.23	LMH
H	8TH EDITION 2023 FBC		

DATE: 9.18.13	DWN BY: MSS	CHK BY:	SCALE: NTS
---------------	-------------	---------	------------

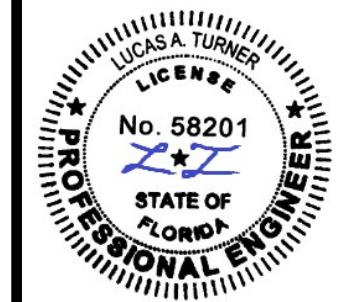

12/4/2023
LUCAS A. TURNER, P.E.
FL PE # 58201
TURNER ENGINEERING & CONSULTING, INC.
(COA # 29779)
2428 OLD NATCHEZ TRACE
TRAIL, CAMDEN, TN 38320
PH. 941-380-1574

FL#: 16103

DWG #: PGWI8IFL

SHEET: 2 OF 5

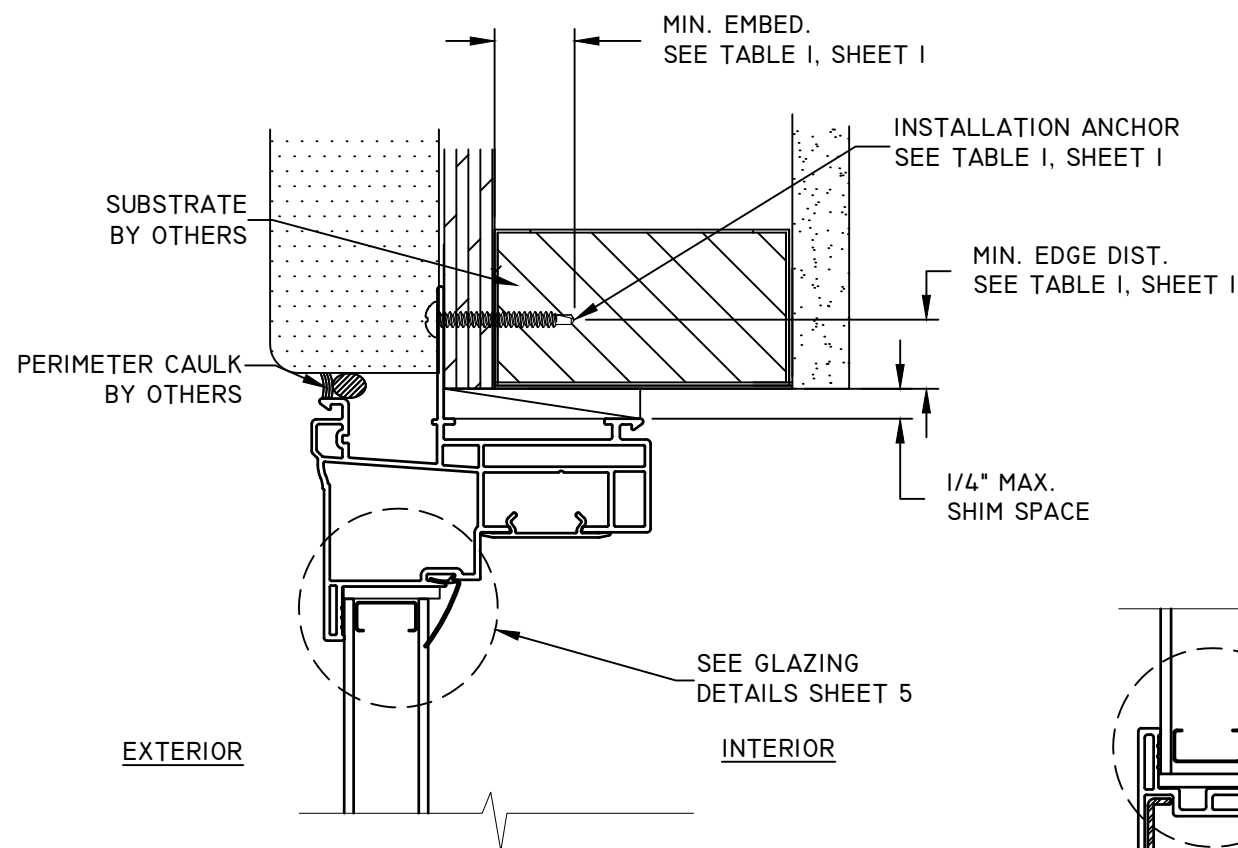

B
3
VERTICAL SECTION
HEAD
BRICKMOULD FRAME - FIN INSTALLATION

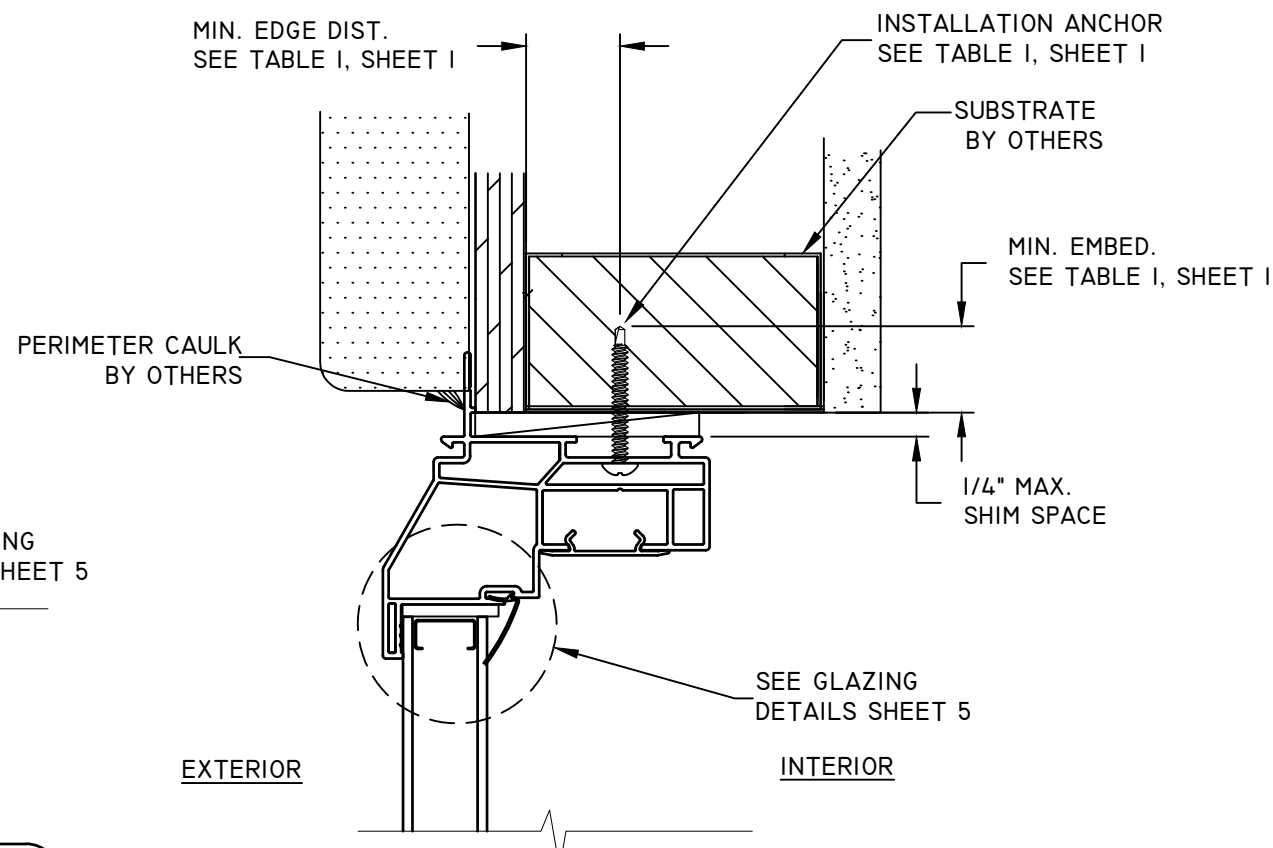

C
3
VERTICAL SECTION
HEAD
BEVELED FRAME - FRAME INSTALLATION

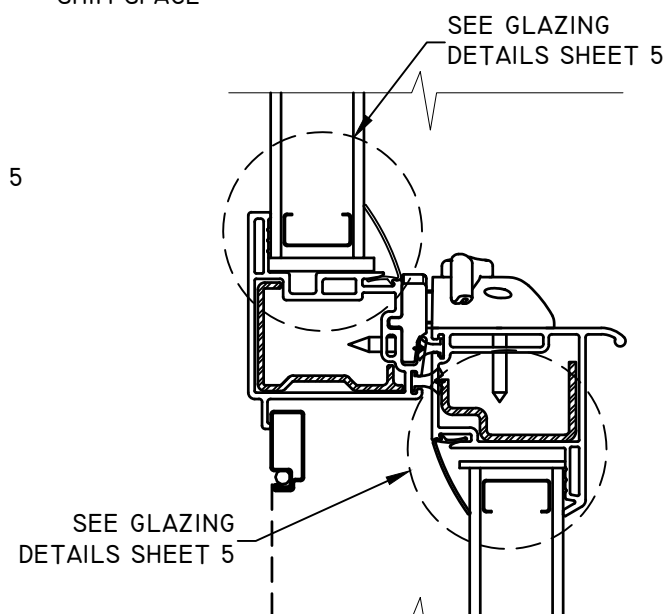

I
3
VERTICAL SECTION
MEETING RAIL
TYPICAL

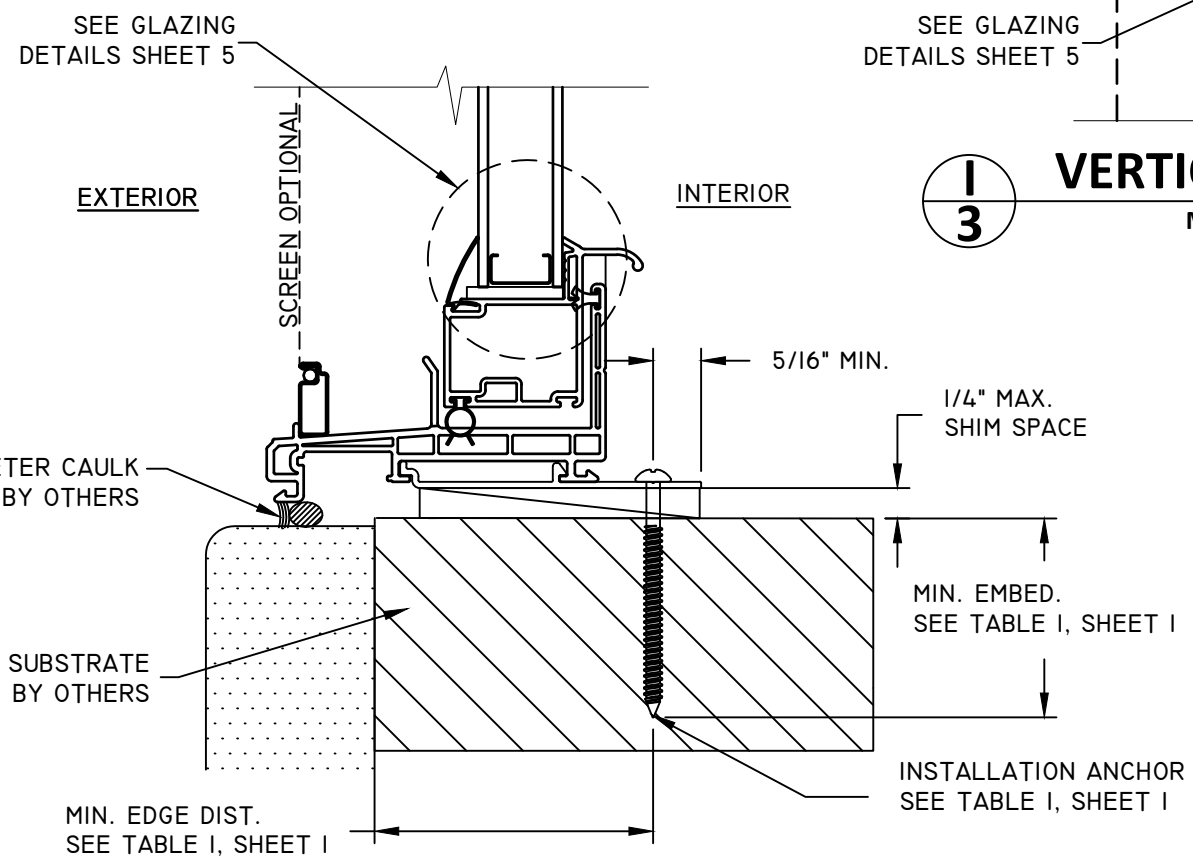

A
3
VERTICAL SECTION
SILL
BRICKMOULD FRAME - CLIP INSTALLATION

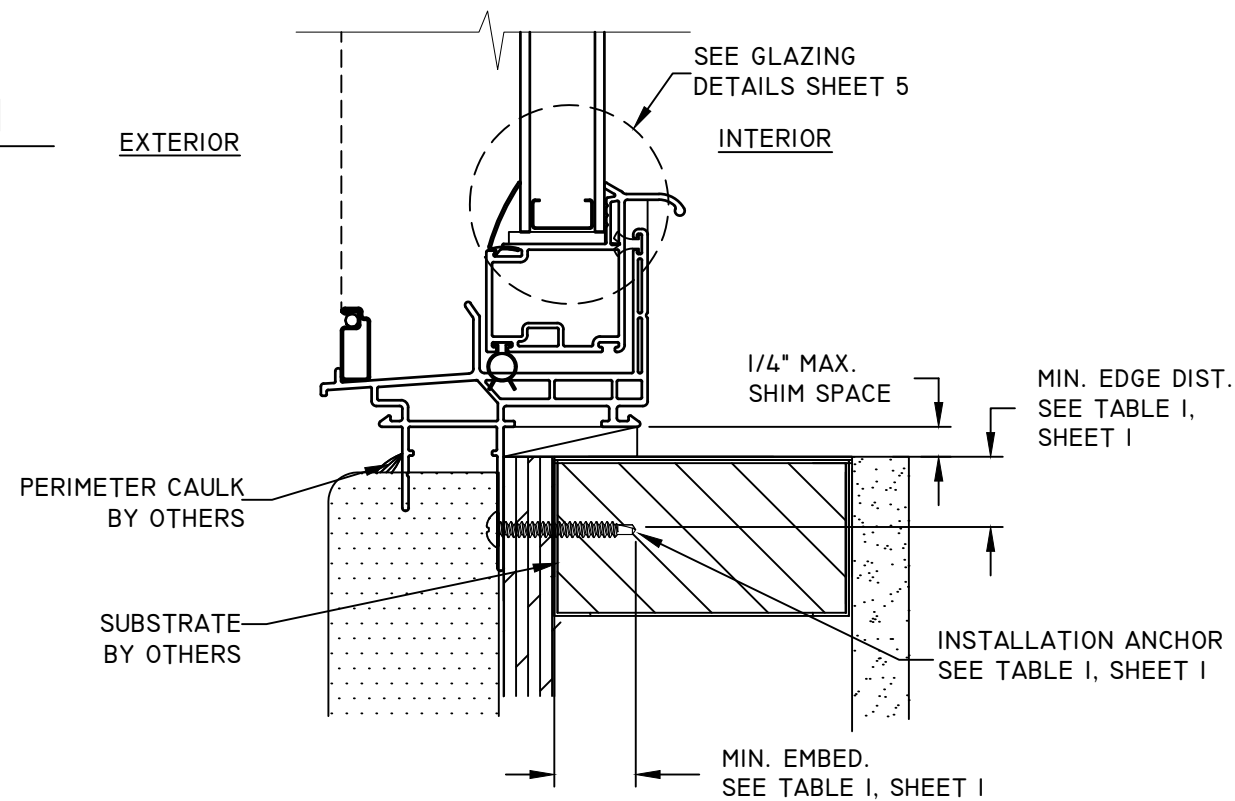

D
3
VERTICAL SECTION
SILL
BEVELED FRAME - FIN INSTALLATION

TITLE: SERIES 1500 SINGLE HUNG WINDOW VERTICAL SECTIONS	NO.	E	F	G	H
	REVISION DESCRIPTION	UPDATED PER EC 07-008 & N18-001, W-1867	UPDATED FRAME ANCHOR LAYOUT.	7TH EDITION 2020 FBC	8TH EDITION 2023 FBC
	BY	LMH	LMH	LMH	LMH
	DATE	07.02.18	10.17.18	12.01.20	12.04.23
DATE:	9.18.13	DWN BY:	MSS	CHK BY:	SCALE:
					NTS

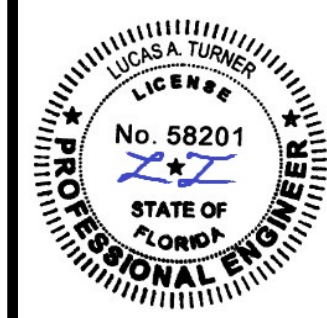

12/04/2023
LUCAS A. TURNER, P.E.
FL PE # 58201
TURNER ENGINEERING &
CONSULTING, INC.
(COA # 29779)
2428 OLD NATCHEZ TRACE
TRAIL, CAMDEN, TN 38320
PH. 941-380-1574

FL#: **16103**
DWG #: **PGWI8IFL**
SHEET: **3 OF 5**

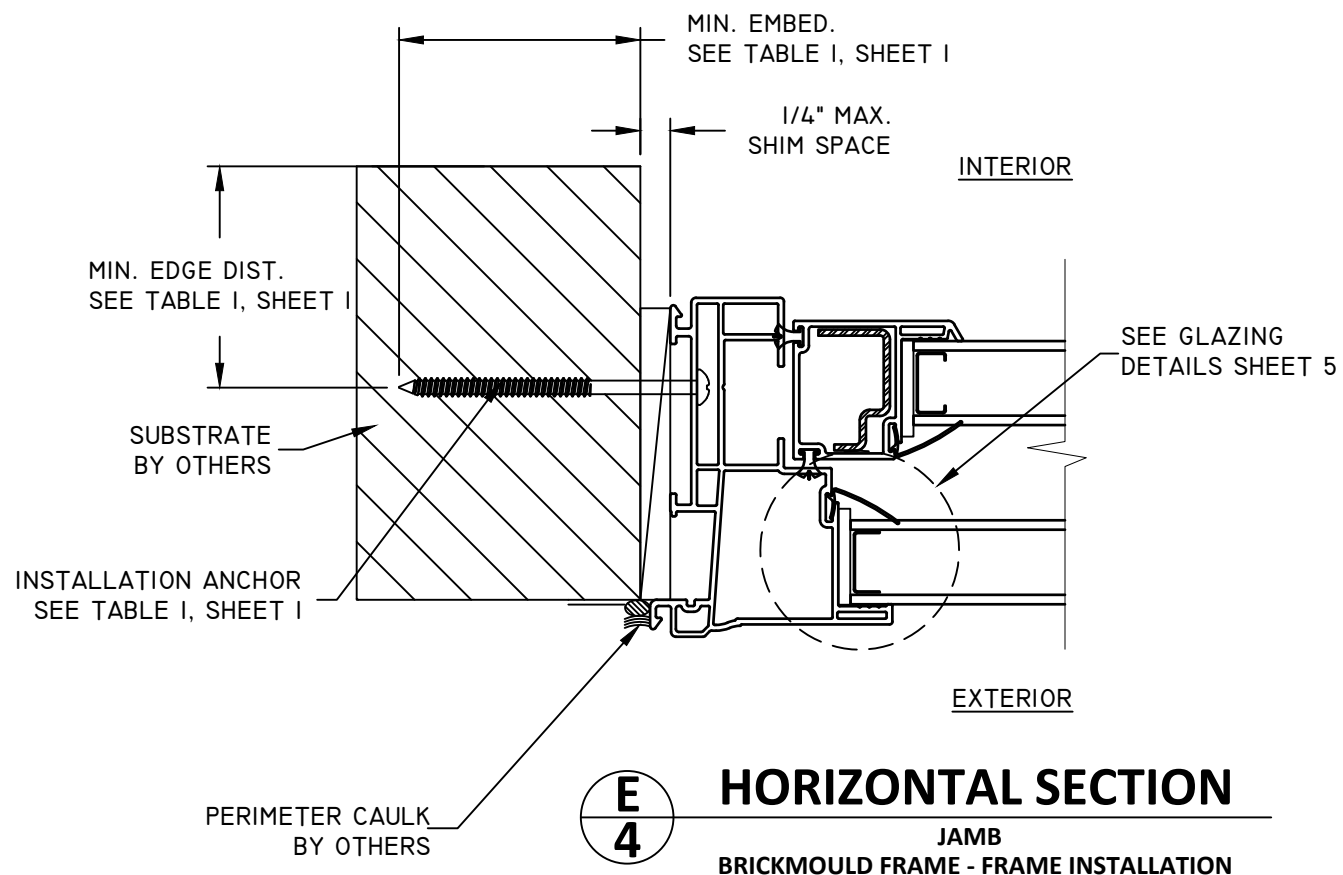

E
4
HORIZONTAL SECTION
JAMB
BRICKMOULD FRAME - FRAME INSTALLATION

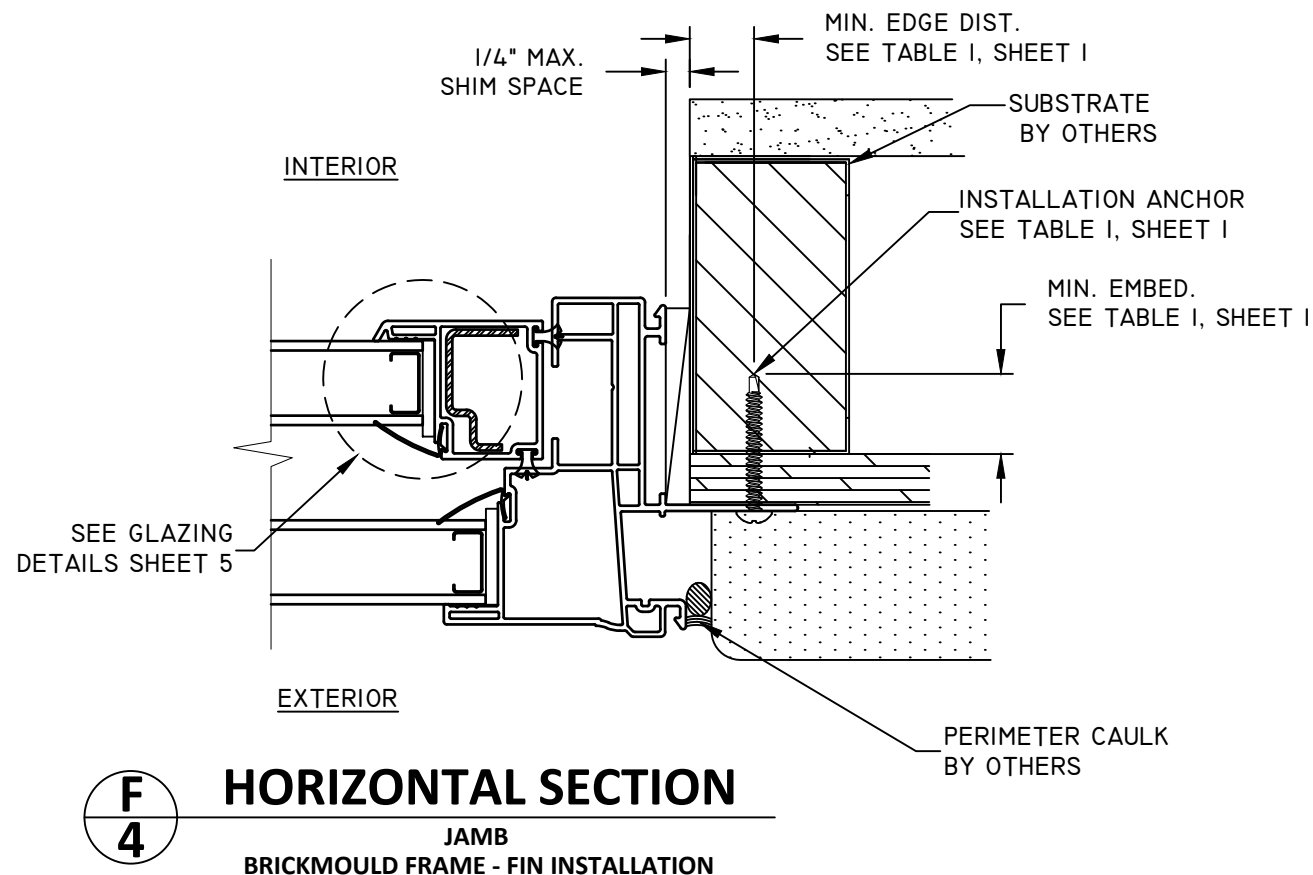

F
4
HORIZONTAL SECTION
JAMB
BRICKMOULD FRAME - FIN INSTALLATION

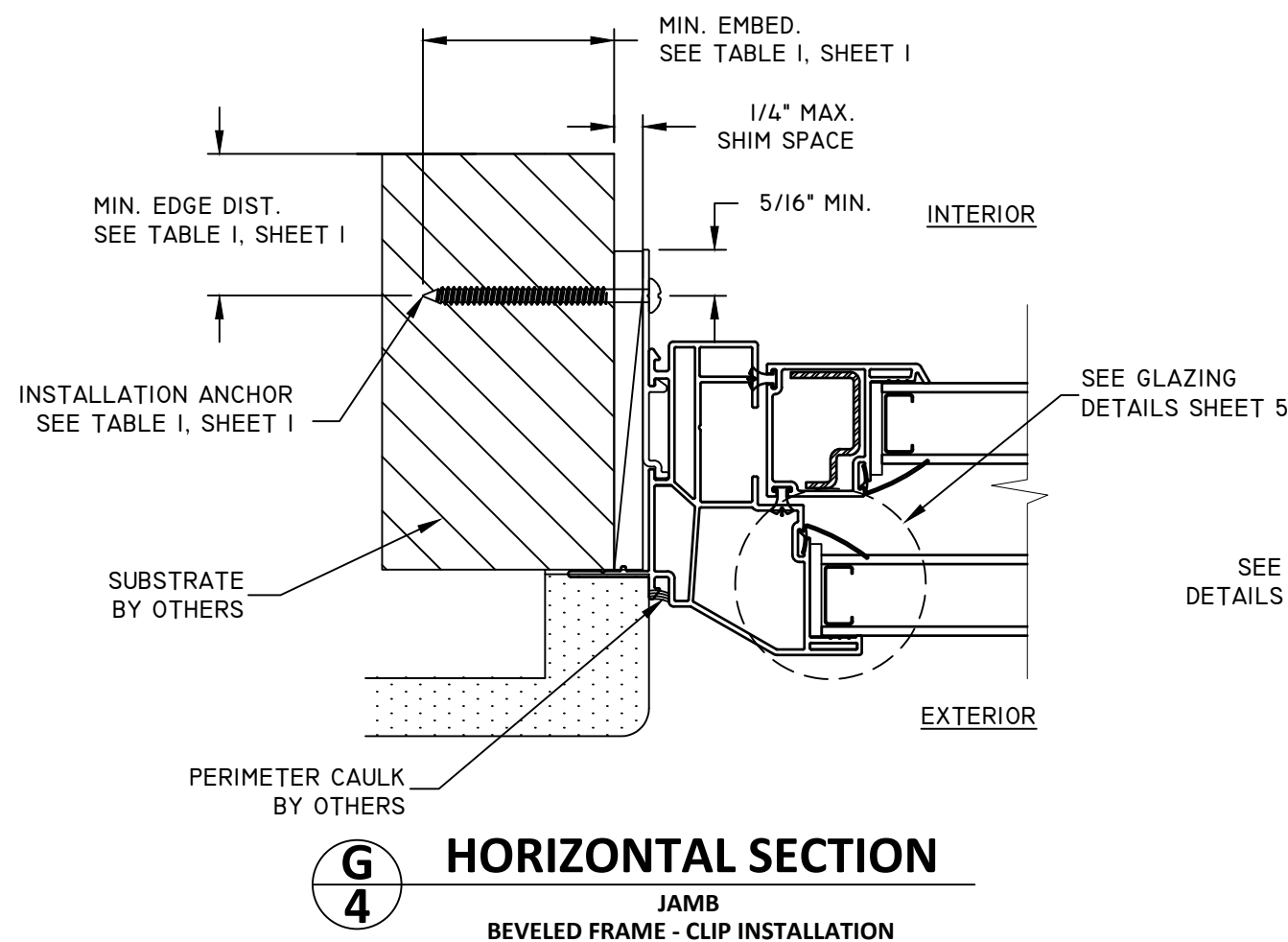

G
4
HORIZONTAL SECTION
JAMB
BEVELED FRAME - CLIP INSTALLATION

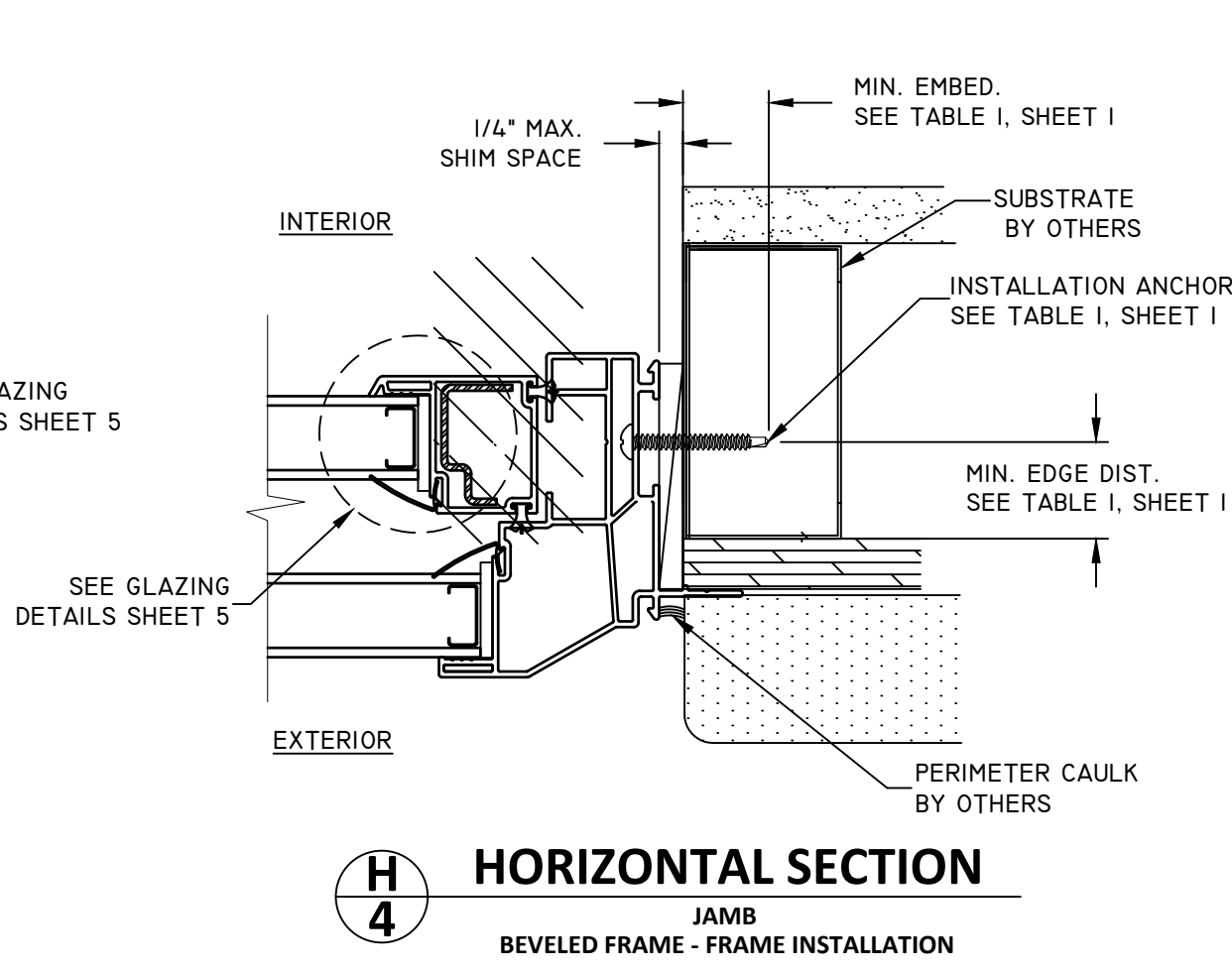

H
4
HORIZONTAL SECTION
JAMB
BEVELED FRAME - FRAME INSTALLATION

TITLE: SERIES 1500 SINGLE HUNG WINDOW HORIZONTAL SECTIONS	NO.	REVISION DESCRIPTION	BY	DATE
	E	UPDATED PER EC 07-008 & N18-001, W-1867	LMH	07.02.18
	F	UPDATED FRAME ANCHOR LAYOUT.	LMH	10.17.18
	G	7TH EDITION 2020 FBC	LMH	12.01.20
	H	8TH EDITION 2023 FBC	LMH	12.04.23
DATE:	DWN BY:	CHK BY:	SCALE:	
9.18.13	MSS		NTS	

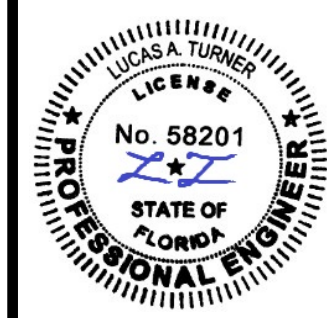

12/04/2023
LUCAS A. TURNER, P.E.
FL PE # 58201
TURNER ENGINEERING &
CONSULTING, INC.
(COA # 29779)
2428 OLD NATCHEZ TRACE
TRAIL, CAMDEN, TN 38320
PH. 941-380-1574

FL#: **16103**
DWG #: **PGWI8IFL**
SHEET: **4 OF 5**

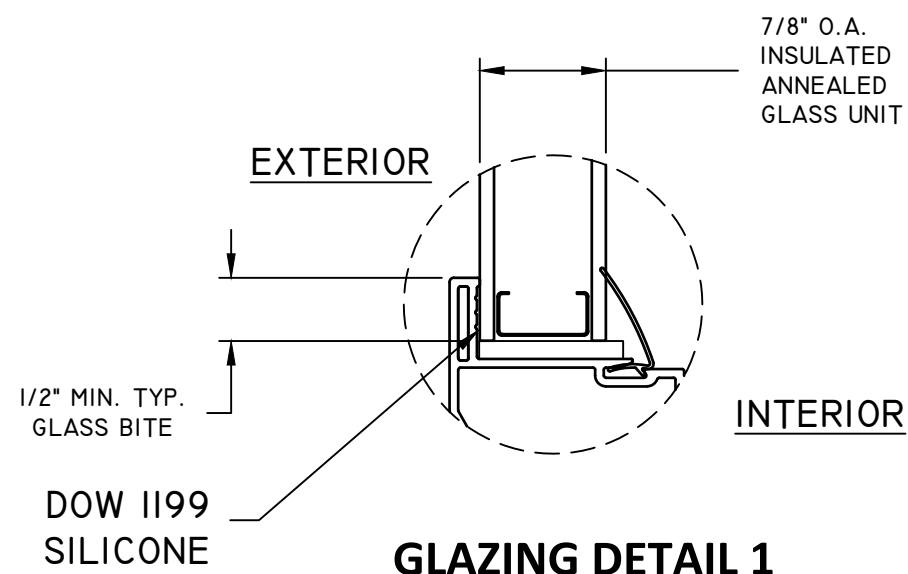

GLAZING DETAIL 1

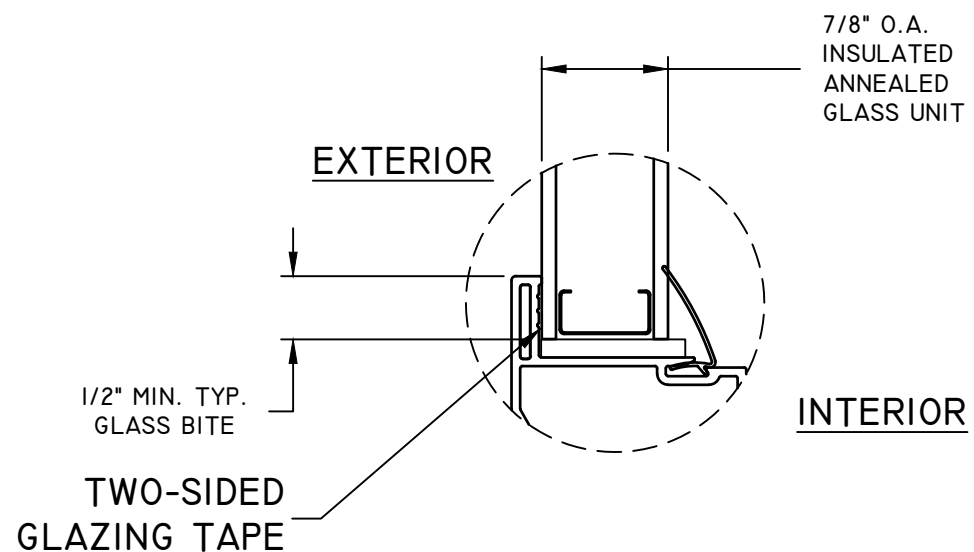

GLAZING DETAIL 2

APPLICABLE TO FIXED LITE ONLY
FOR SASH SEE GLAZING DETAIL 1

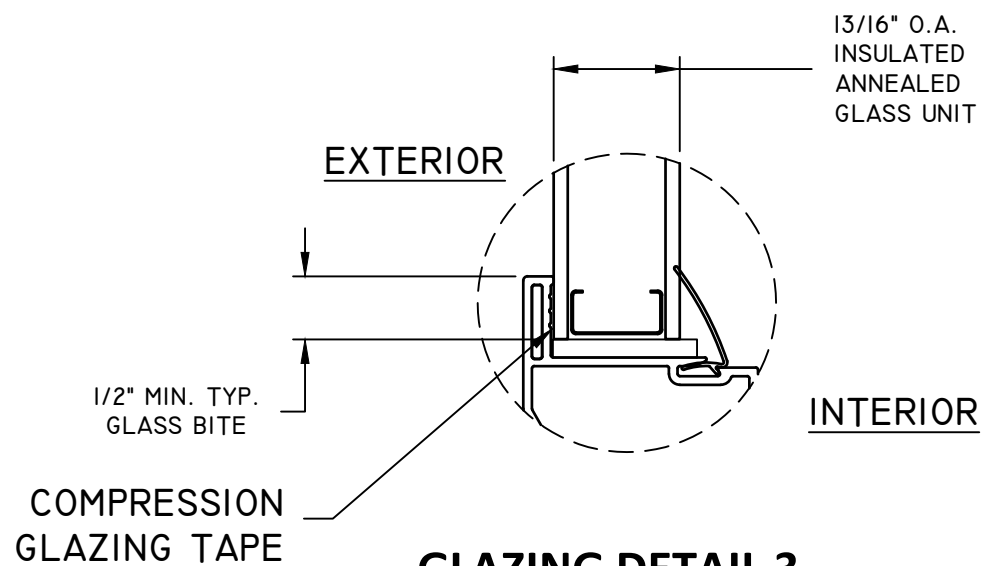

GLAZING DETAIL 3

APPLICABLE TO FIXED LITE ONLY
FOR SASH SEE GLAZING DETAIL 1

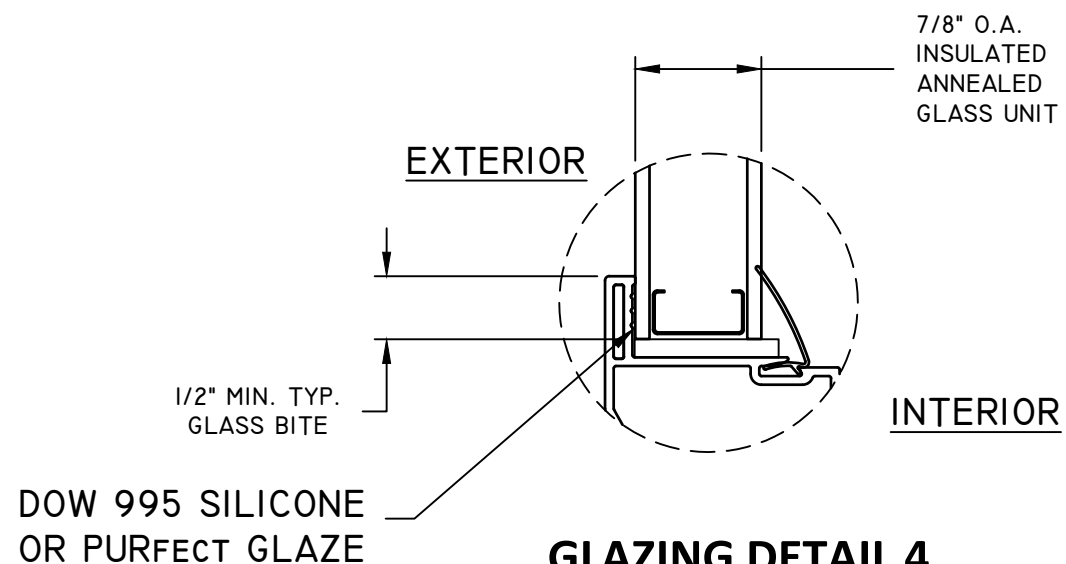

GLAZING DETAIL 4

TITLE: SERIES 1500 SINGLE HUNG WINDOW GLAZING DETAILS		NO.	REVISION DESCRIPTION	BY	DATE
		E	UPDATED PER EC 07-008 & N18-001, W-1867	LMH	07.02.18
		F	UPDATED FRAME ANCHOR LAYOUT.	LMH	10.17.18
		G	7TH EDITION 2020 FBC	LMH	12.01.20
		H	8TH EDITION 2023 FBC	LMH	12.04.23

DATE: 9.18.13	DWN BY: MSS	CHK BY:	SCALE: NTS
------------------	----------------	---------	---------------

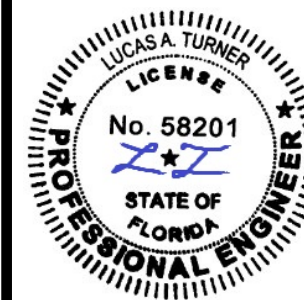

12/04/2023
LUCAS A. TURNER, P.E.
FL PE # 58201
TURNER ENGINEERING &
CONSULTING, INC.
(COA # 29779)
2428 OLD NATCHEZ TRACE
TRAIL, CAMDEN, TN 38320
PH. 941-380-1574

FL#: 16103

DWG #: PGWI8IFL

SHEET: 5 OF 5