

Doors tested per ANSI/DASMA 108 for static air pressure

TH160 / TM175 / TM200 / TM220		
Maximum Door Width	Center Hinges per Section	Design Load
Up to 9' - 2"	1	+ 39.3 - 44.0
10' - 2"	2	+ 30.3 - 33.6
11' - 2"	2	+ 27.8 - 30.8
12' - 2"	3	+ 25.7 - 28.5
13' - 2"	3	+ 23.9 - 26.5
14' - 2"	3	+ 22.3 - 24.7
15' - 2"	3	+ 20.9 - 23.2



Scott A. Brown, P.E. Lic. No. 65940  
 Wender Engineering Services, Inc.  
 698 Timber Creek Road, Dixon, IL 61021  
 FBPE CA Lic. No. 31544  
 Structural Adequacy for Wind Load

Printed copies of this document are not considered signed and sealed and the SHA authentication code must be verified on any electronic copies.

E	Concrete and CMU lap requirement was 2.00 on clip angle.	8517.02	09/10/21	Scale: None	<p>1101 East River Road                  Dixon, IL 61021</p>	Title: Spec, Wind Load TH160, TM175, TM200, TM220 No. P-2423 Sheet 1 of 4 Rev E
D	Added pre-assembled track, 34 x 16 windows, TM220 and updated format.	8517.01	02/18/21	Drawn by: G. Wedekind		
C	1) Was Richard A Baumann, P.E., 2) Updated jamb attachments.	7803.01	09/29/17	Checked by: G. Wedekind		
Rev.	Description	ECO	Date	Date: 02/15/13 ECO: 6530.01		

**Jamb Attachment Notes:**

1. Maximum Positive Load per Jamb =  $(10'-2" \times 39.3 \text{ PSF}) / 2 = 201 \text{ lbs. per foot.}$
2. Maximum Negative Load per Jamb =  $(10'-2" \times -44.0 \text{ PSF}) / 2 = 225 \text{ lbs. per foot.}$
3. Design of the supporting structure shall be the sole responsibility of the building designer and shall be designed for the jamb loads listed in notes 1 and 2.
4. Alternate jamb attachments may be used if approved by a registered Professional Engineer.
5. DASMA Technical Data Sheet TDS-161 may be used for alternate jamb attachments.
6. 3/8" diameter lag screws required 1/4" pilot hole and 1-1/2" minimum required distance.
7. Masonry fasteners by others.

2x6 Attachment to Structure						
Structure Type	Fastener Type	Minimum Embedment	Minimum Edge Distance	Minimum on Center Spacing	Maximum on Center Spacing	Allowable Tension Load
2500 PSI Min. Concrete	1/4" Tapcon+ (Plus) with 1-1/8" OD Washer	2"	2.5"	6"	24"	526
Southern Pine	3/8" x 3" Lag with 1-1/8" OD Washer	1.50"	1.50"	1.50"	24"	655
Spruce Pine Fir	3/8" x 3" LAG with 1-1/8" OD Washer	1.50"	1.50"	1.50"	24"	482

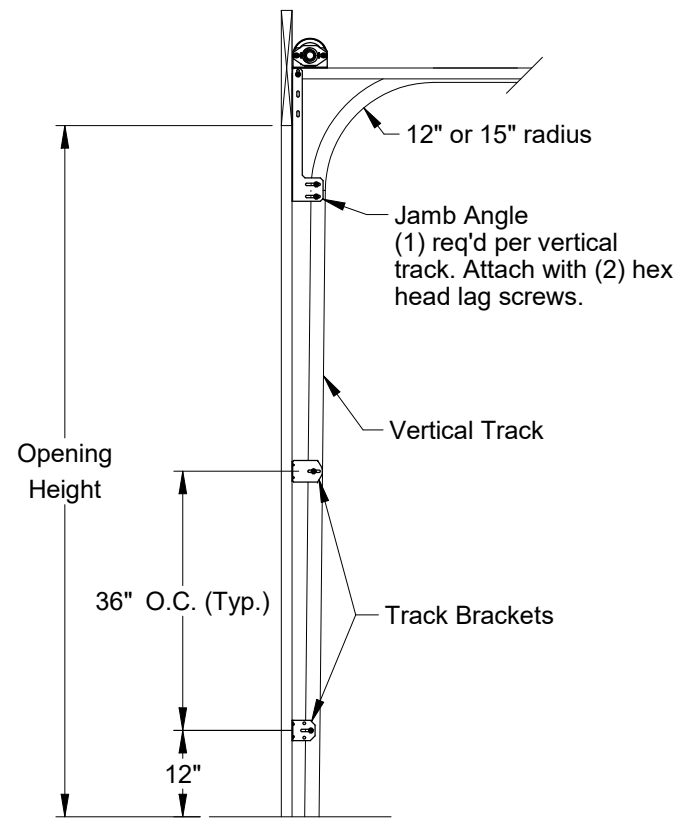
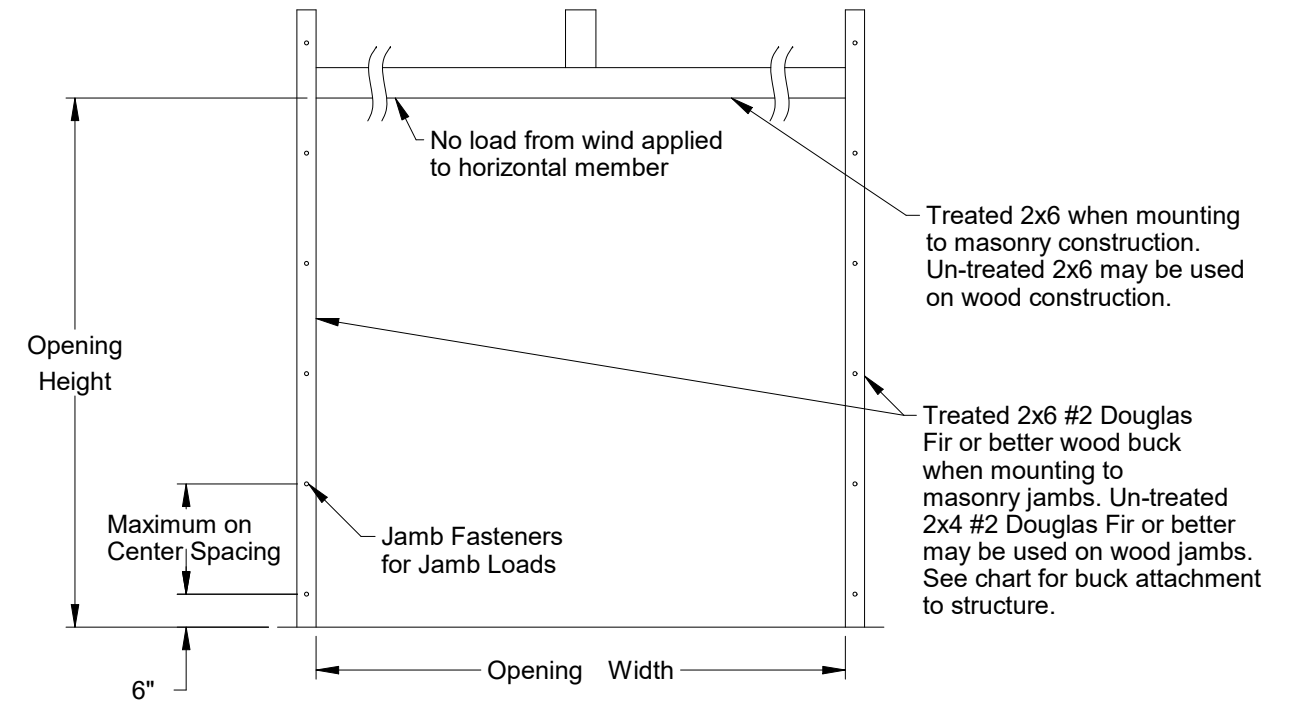

**Typical Track Installation  
Bracket Mount  
Wood Jamba**

Normal headroom track shown, low headroom, lift clearance and verical lift track available.

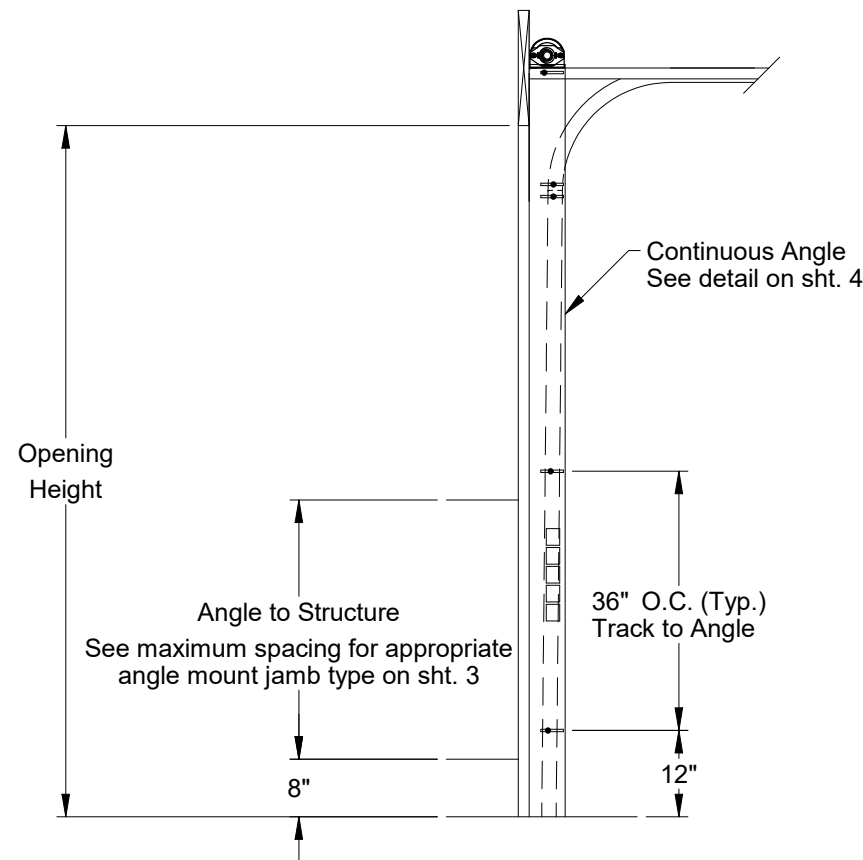

**Typical Track Installation  
Angle Mount  
Wood, Steel or Concrete Jamba**

Normal headroom track shown, low headroom, lift clearance and verical lift track available.

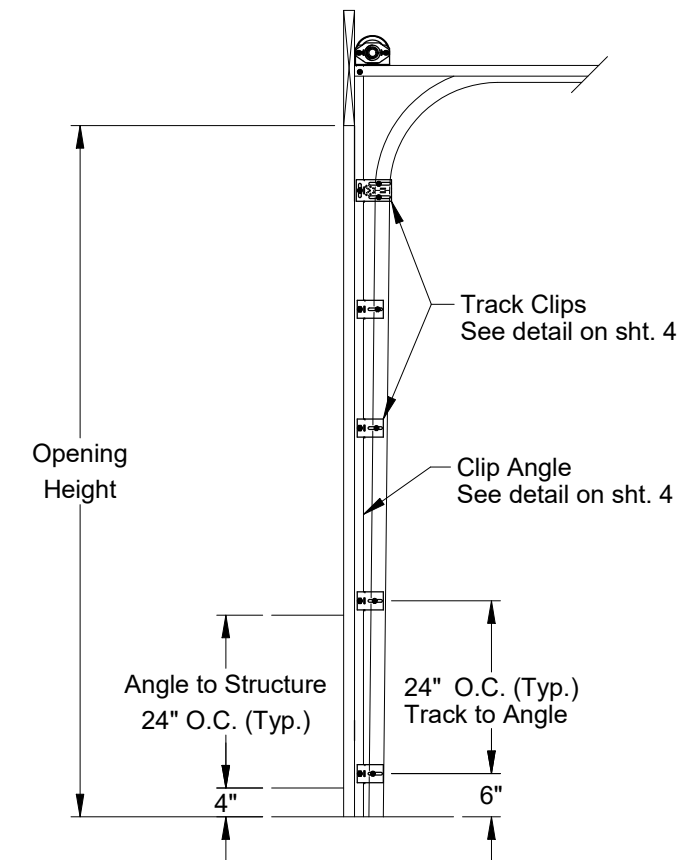

**Typical Track Installation  
Pre-Assembled Clip Angle  
Wood, Steel or Concrete Jamba**

Normal headroom track shown, lift clearance and verical lift track available.



Scott A. Brown, P.E. Lic. No. 65940  
Wendler Engineering Services, Inc.  
698 Timber Creek Road, Dixon, IL 61021  
FBPE CA Lic. No. 31544  
Structural Adequacy for Wind Load

Scale: None	 1101 East River Road Dixon, IL. 61021	Title: Spec, Wind Load TH160, TM175, TM200, TM220	
Drawn by: G. Wedekind		No. P-2423	Sheet 2
Checked by: G. Wedekind			
Date: 02/15/13		Rev E	
ECO: 6530.01			

Angle Mount					
Jamb Type	Fastener Type	Minimum Embedment (in.)	Minimum Edge Distance (in.)	Maximum on Center Spacing (in.)	Allowable Tension Load (lbs.)
2500 PSI Min. Concrete	3/8" ITW Trubolt	2-1/2"	2-1/2"	36"	893
	1/4" Tapcon+ (Plus) with 1-1/8" OD Washer	2"	1-5/8"	36"	687
	1/4" x 2-5/8" Screw-Bolt+ with 9/16" OD Washer	2-1/2"	1-1/2"	36"	651
Steel	5/16" x 1" SAE J78, Min. AISI 1022 with 5/16" Washer	3/16"	1-1/2"	36"	971
Wood	5/16" x 1-3/4" Lag with 5/16" Washer	1-1/2"	1-1/2"	18"	352
Grout Filled CMU Block	3/8" Simpson Titen HD	2-3/4"	4"	18"	480

Alternate fasteners may be used if approved by a registered Professional Engineer.

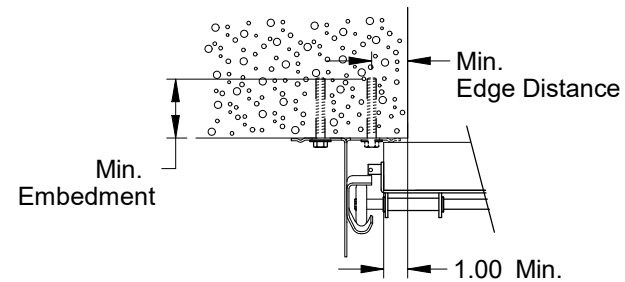

**Track Assembly Attachment to 2500 PSI Min. Concrete**  
 2" Angle mount turned-out standard (solid)  
 2" Angle mount turned-in optional (dashed)  
 3" Angle mount available

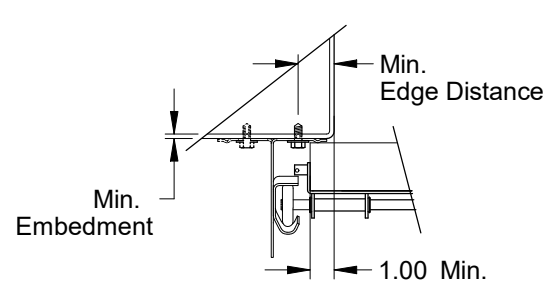

**Track Assembly Attachment to 3/16" Min. Steel Jamb**  
 2" Angle mount turned-out standard (solid)  
 2" Angle mount turned-in optional (dashed)  
 3" Angle mount available

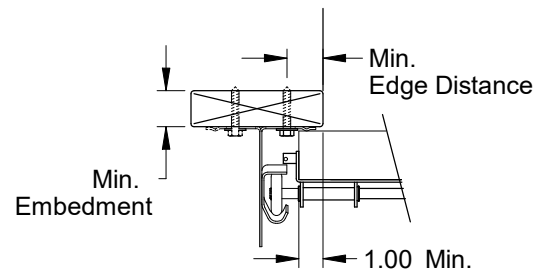

**Track Assembly Attachment to Wood Jamb**  
 2" Angle mount turned-out standard (solid)  
 2" Angle mount turned-in optional (dashed)  
 3" Angle mount available

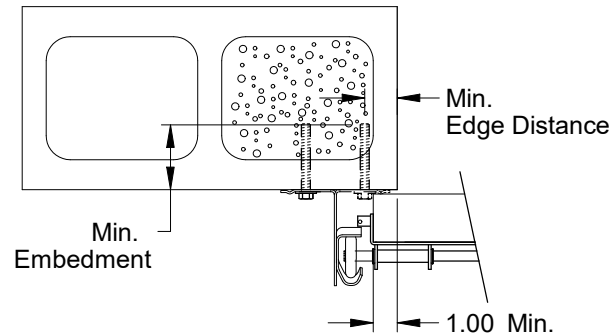

**Track Assembly Attachment to Grout Filled CMU Block**  
 2" Angle mount turned-out standard (solid)  
 2" Angle mount turned-in optional (dashed)  
 3" Angle mount available



Scott A. Brown, P.E. Lic. No. 65940  
 Wender Engineering Services, Inc.  
 698 Timber Creek Road, Dixon, IL 61021  
 FBPE CA Lic. No. 31544  
 Structural Adequacy for Wind Load

Pre-Assembled Clip Angle					
Jamb Type	Fastener Type	Minimum Embedment (in.)	Minimum Edge Distance (in.)	Maximum on Center Spacing (in.)	Allowable Tension Load (Lbs.)
2500 PSI Min. Concrete	3/8" ITW Trubolt	2-1/2"	2-1/2"	24"	893
	1/4" Tapcon+ (Plus) with 1-1/8" OD Washer	2"	1-5/8"	24"	687
	1/4" x 2-5/8" Screw-Bolt+ with 9/16" OD Washer	2-1/2"	1-1/2"	24"	651
Steel	5/16" x 1" SAE J78, Min. AISI 1022 with 5/16" Washer	3/16"	1-1/2"	24"	971
Wood	5/16" x 1-3/4" Lag with 5/16" Washer	1-1/2"	1-1/2"	*21"	352
Grout Filled CMU Block	3/8" Simpson Titen HD	2-3/4"	4"	24"	480

\* Field drilling req'd.

Alternate fasteners may be used if approved by a registered Professional Engineer.

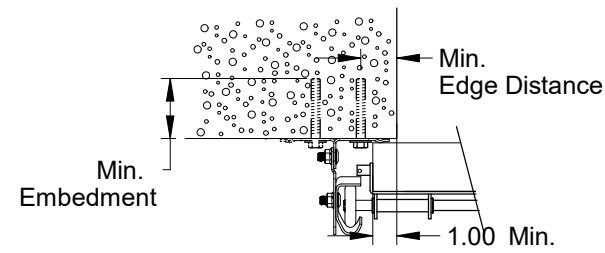

**Pre-Assembled Track Assembly Attachment to 2500 PSI Min. Concrete**  
 2" Clip angle turned-in standard (solid)  
 2" Clip angle turned-out optional (dashed)  
 3" Clip angle available

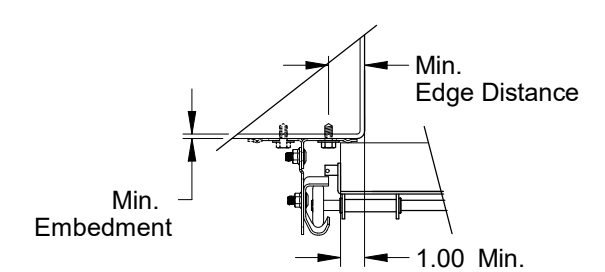

**Pre-Assembled Track Assembly Attachment to 3/16" Min. Steel Jamb**  
 2" Clip angle turned-in standard (solid)  
 2" Clip angle turned-out optional (dashed)  
 3" Clip angle available

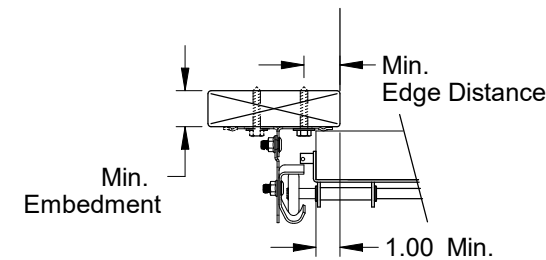

**Pre-Assembled Track Assembly Attachment to Wood Jamb**  
 2" Clip angle turned-in standard (solid)  
 2" Clip angle turned-out optional (dashed)  
 3" Clip angle available

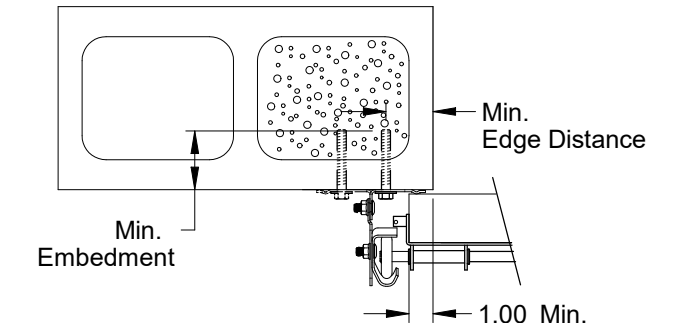

**Pre-Assembled Track Assembly Attachment to Grout Filled CMU Block**  
 2" Clip angle turned-in standard (solid)  
 2" Clip angle turned-out optional (dashed)  
 3" Clip angle available

Scale: None
Drawn by: G. Wedekind
Checked by: G. Wedekind
Date: 02/15/13
ECO: 6530.01



Title: Spec, Wind Load TH160, TM175, TM200, TM220	
No. P-2423	Rev E
Sheet 3	

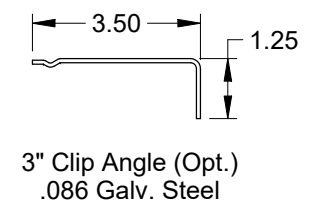
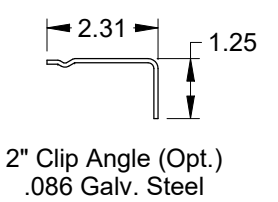
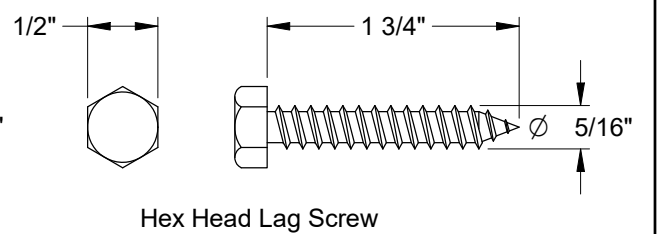
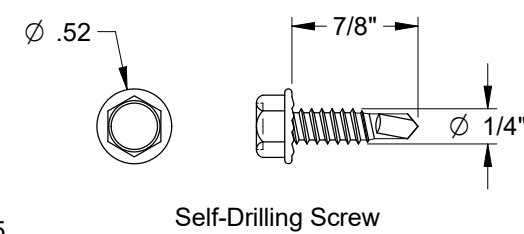
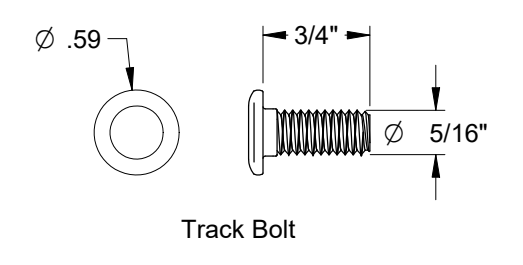
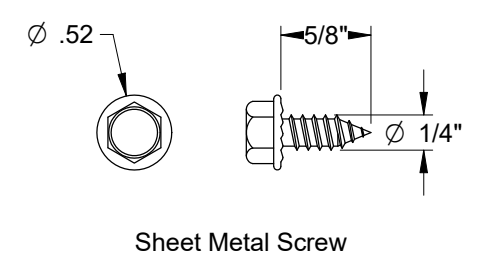
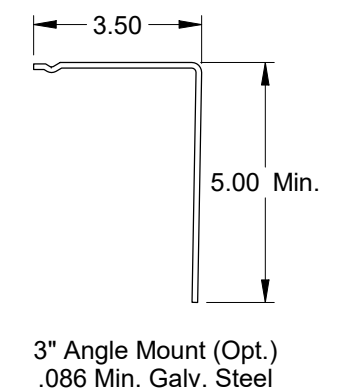
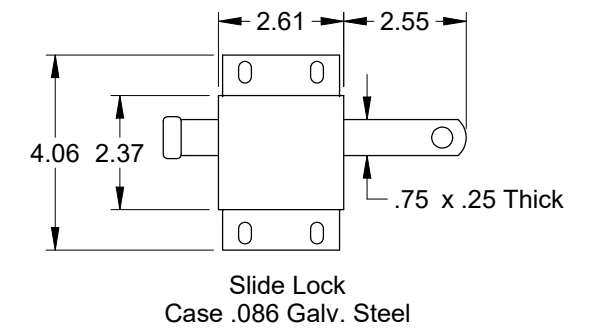
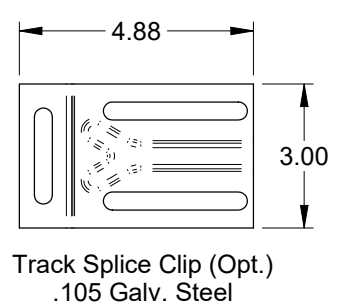
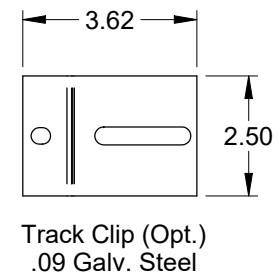
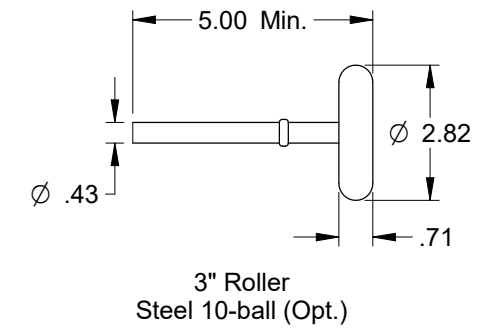
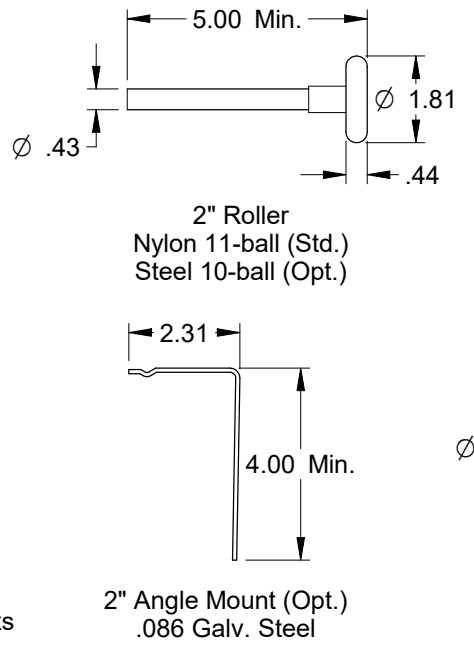
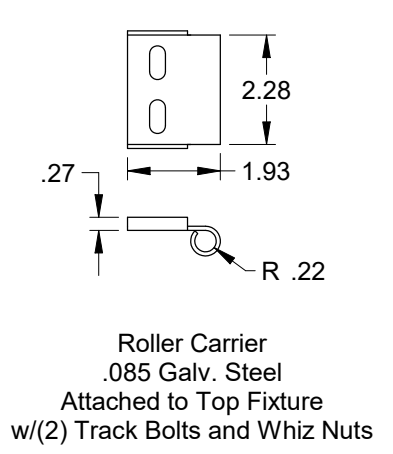
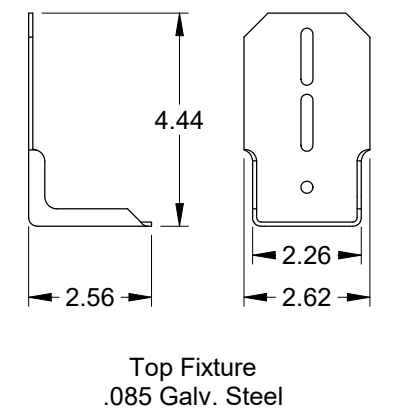
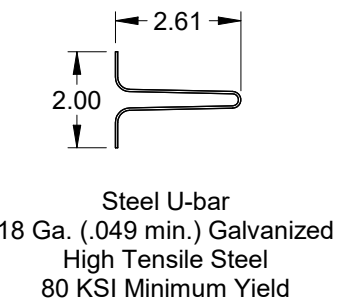
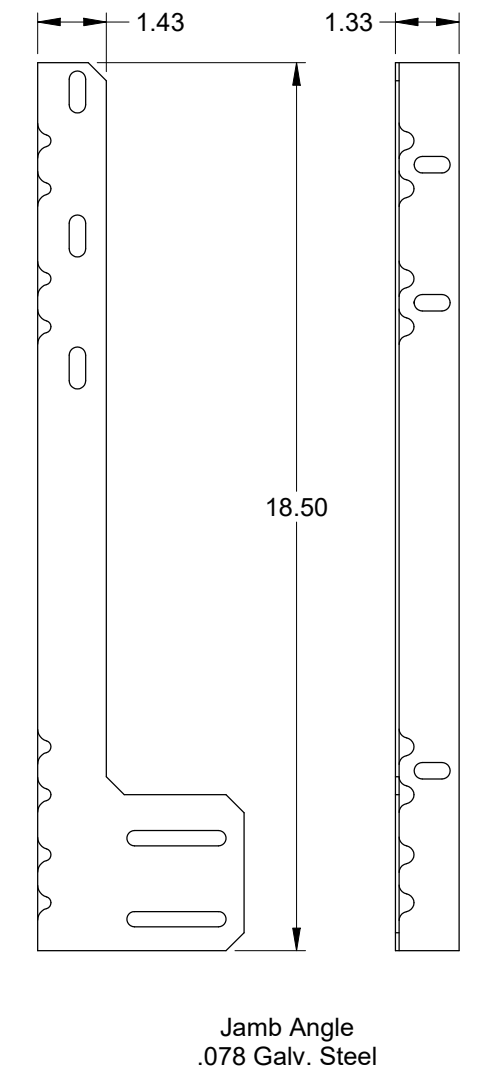
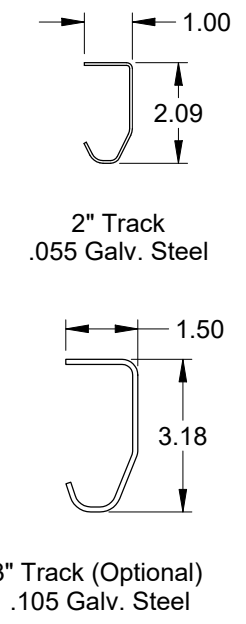
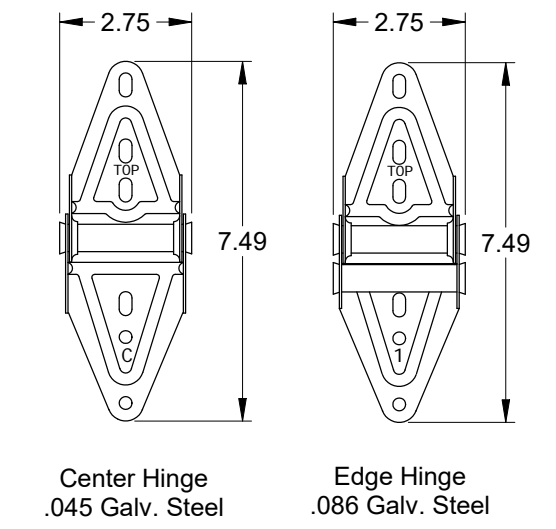
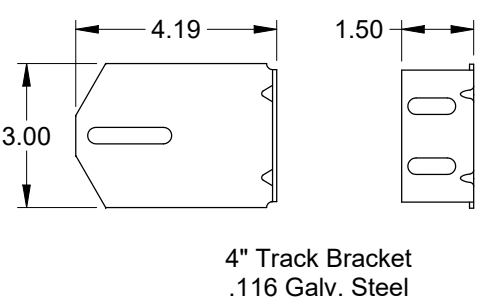
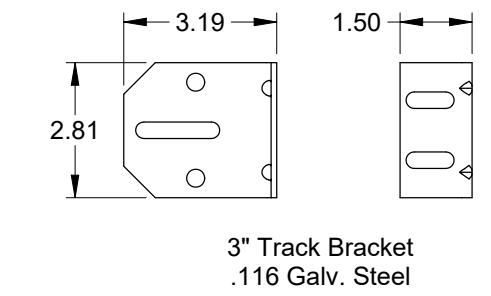
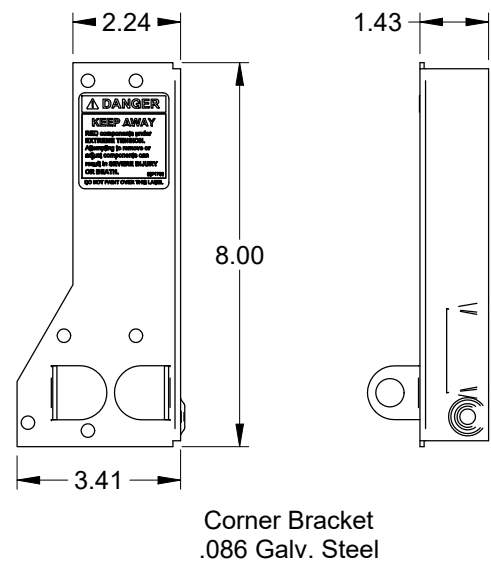

Scott A. Brown, P.E. Lic. No. 65940  
Wendler Engineering Services, Inc.  
698 Timber Creek Road, Dixon, IL 61021  
FBPE CA Lic. No. 31544  
Structural Adequacy for Wind Load

Printed copies of this document are not considered signed and sealed and the SHA authentication code must be verified on any electronic copies.

Scale: None
Drawn by: G. Wedekind
Checked by: G. Wedekind
Date: 02/15/13
ECO: 6530.01



Title: Spec, Wind Load TH160, TM175, TM200, TM220		
No. P-2423	Sheet 4	Rev E