

Doors tested per ANSI/DASMA 108 for static air pressure

Maximum Door Width	Qty. of Stiles	Design Load	
8'-2"	1	47.3	-53.5
9'-2"	2	42.1	-47.7
10'-2"	2	38.0	-43.0
12'-2"	2	26.5	-30.0
14'-2"	3	23.3	-25.9
16'-2"	3	20.4	-22.7
18'-2"	4	16.2	-18.0

Scott A. Brown, P.E. Lic. No. 65940
 Wendler Engineering Services, Inc.
 698 Timber Creek Road, Dixon, IL 61021
 FBPE CA Lic. No. 31544
 Structural Adequacy for Wind Load

Printed copies of this document are not considered signed and sealed and the SHA authentication code must be verified on any electronic copies.

Rev.	Description	ECO	Date
A	New release for production.	8132.01	03/21/19

Scale: None	<p>1101 East River Road Dixon, IL. 61021</p>	Title: Spec, Wind Load AlumaView - AV300	
Drawn by: R. Frey		No. P-2434	Sheet 1 of 3
Checked by: G. Wedekind			
Date: 03/21/19	ECO: 8132.01		

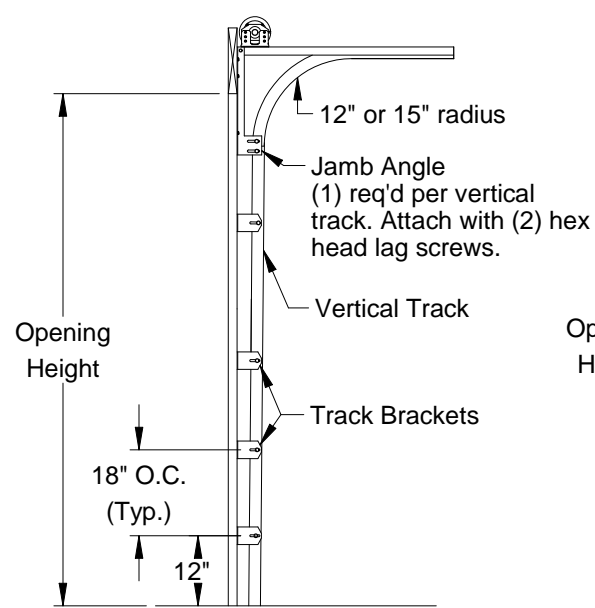

**Typical Track Installation
Bracket Mount
Wood Jamb**

Normal headroom track shown, low headroom, lift clearance and vertical lift track available

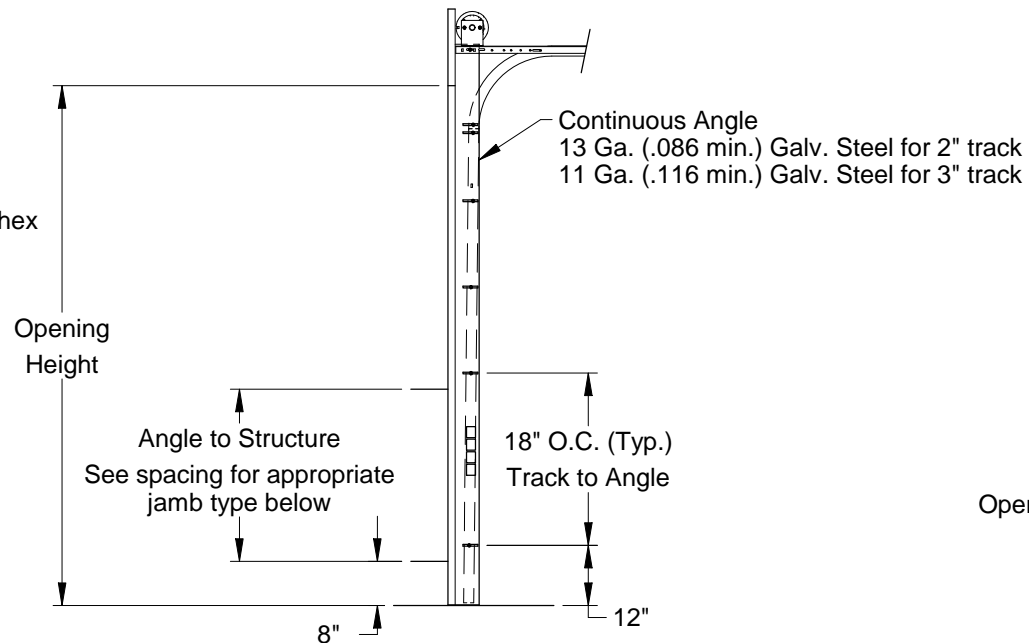

**Typical Track Installation
Angle Mount
Wood, Steel or Concrete Jamb**

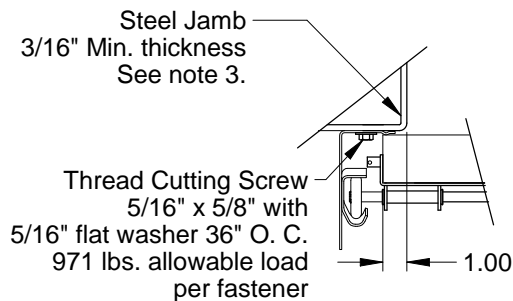
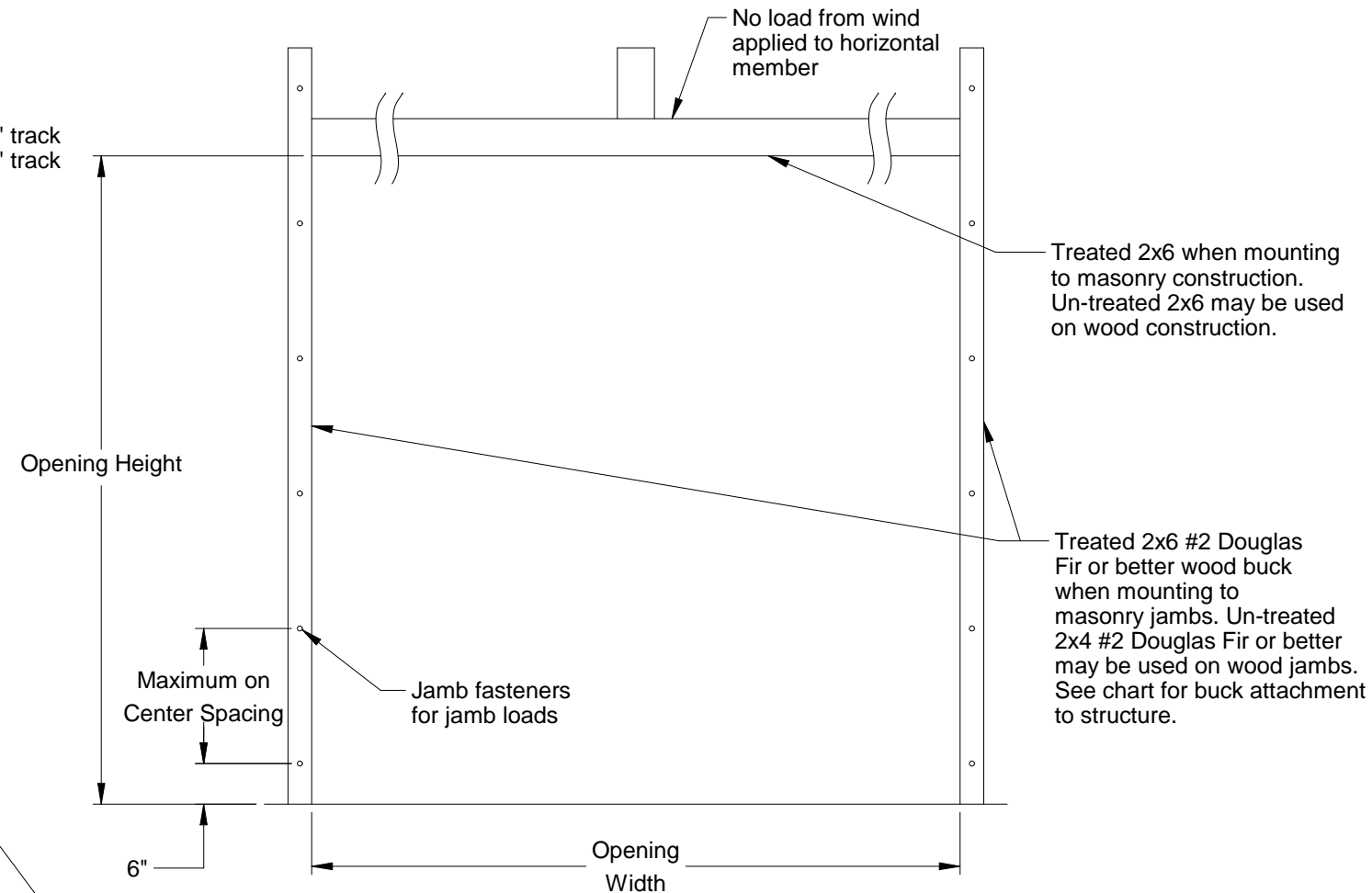

**Track Assembly Attachment
to Steel Jamb**
2" Track Angle Mount Turned-in (shown)
3" Track Angle Mount Available

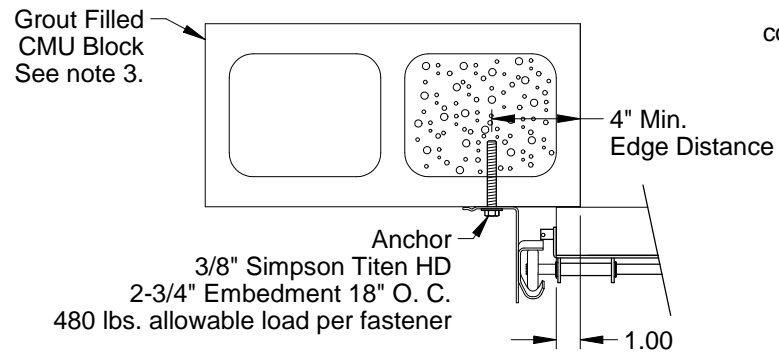

**Track Assembly Attachment
to Grout Filled CMU Block**
2" Track Angle Mount Turned-out (shown)
3" Track Angle Mount Available

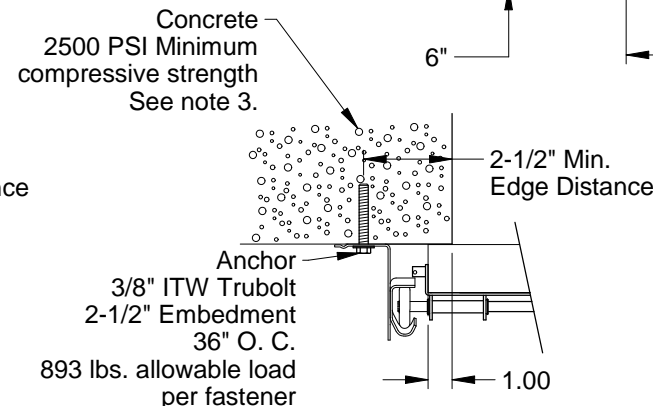

**Track Assembly Attachment
to 2500 PSI Min. Concrete**
2" Track Angle Mount Turned-out (shown)
3" Track Angle Mount Available

Jamb Attachment Notes:

1. Maximum Positive Load per Jamb = $(10'-2" \times 38.0 \text{ PSF}) / 2 = 194 \text{ lbs. per foot.}$
2. Maximum Negative Load per Jamb = $(10'-2" \times -43.0 \text{ PSF}) / 2 = 219 \text{ lbs. per foot.}$
3. Design of the supporting structure shall be the sole responsibility of the building designer and shall be designed for the jamb loads listed in notes 1 and 2.
4. Alternate jamb attachments may be used if approved by a registered Professional Engineer.
5. DASMA Technical Data Sheet TDS-161 may be used for alternate jamb attachments.
6. 3/8" diameter lag screws required 1/16" pilot hole and 1-1/2" minimum required distance.

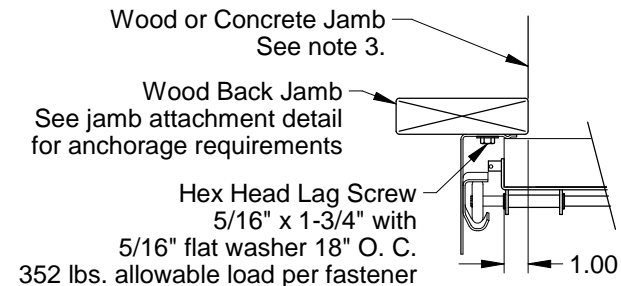

**Track Assembly Attachment
to Wood Back Jamb**
2" Track Angle Mount Turned-in (shown)
3" Track Angle Mount Available

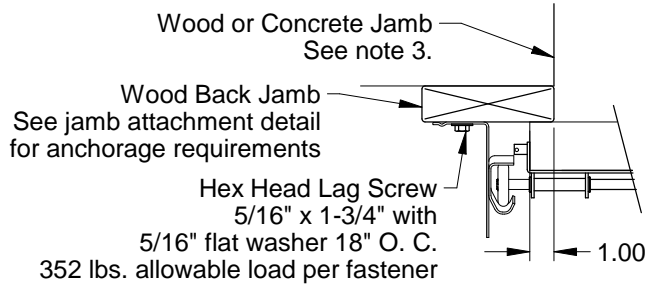

**Track Assembly Attachment
to Wood Back Jamb**
2" Track Angle Mount Turned-out (shown)
3" Track Angle Mount Available

2x6 Attachment to Structure						
Structure Type	Fastener Type	Minimum Embedment	Minimum Edge Distance	Minimum on Center Spacing	Maximum on Center Spacing	Allowable Tension Load
2500 PSI Min. Concrete	1/4" Tapcon+ (Plus) with 1-1/8" OD Washer	2"	2.5"	6"	24"	526
Southern Pine	3/8" x 3" Lag with 1-1/8" OD Washer	1.50"	1.50"	1.50"	24"	655
Spruce Pine Fir	3/8" x 3" LAG with 1-1/8" OD Washer	1.50"	1.50"	1.50"	24"	482

Scott A. Brown, P.E. Lic. No. 65940
Wendler Engineering Services, Inc.
698 Timber Creek Road, Dixon, IL 61021
FBPE CA Lic. No. 31544
Structural Adequacy for Wind Load

Scale: None		Title: Spec, Wind Load AluminaView - AV300	
Drawn by: R. Frey		No. P-2434	Sheet 2
Checked by: G. Wedekind			Rev A
Date: 03/21/19 ECO: 8132.01		1101 East River Road Dixon, IL 61021	

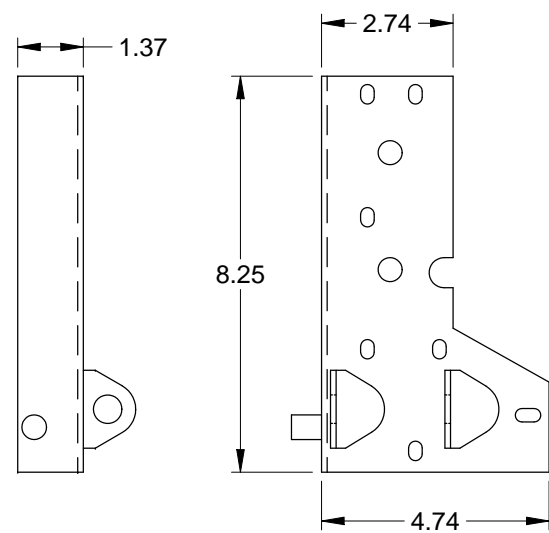

Corner Bracket
(For doors over 600 lbs.)
.116 Galv. Steel

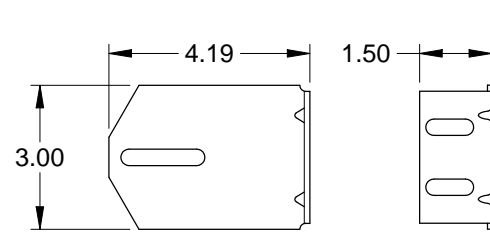

4" Track Bracket
.116 Galv. Steel

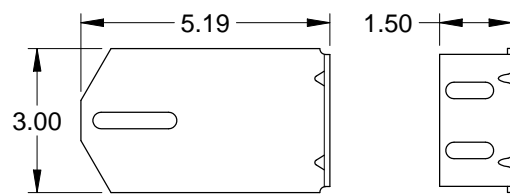

5" Track Bracket
.116 Galv. Steel

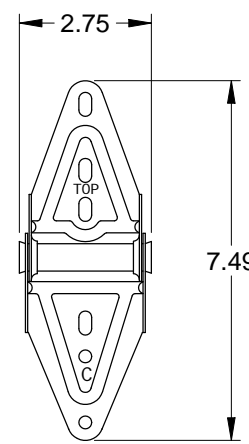

Center Hinge
.045 Galv. Steel

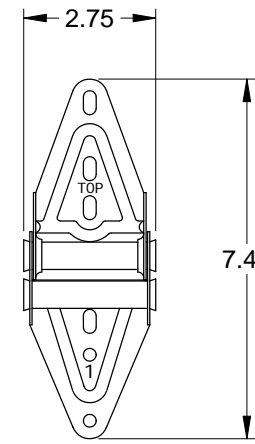

Edge Hinge
.086 Galv. Steel

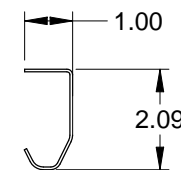

2" Track
.086 Galv. Steel

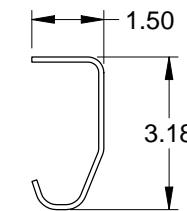

3" Track (Optional)
.105 Galv. Steel

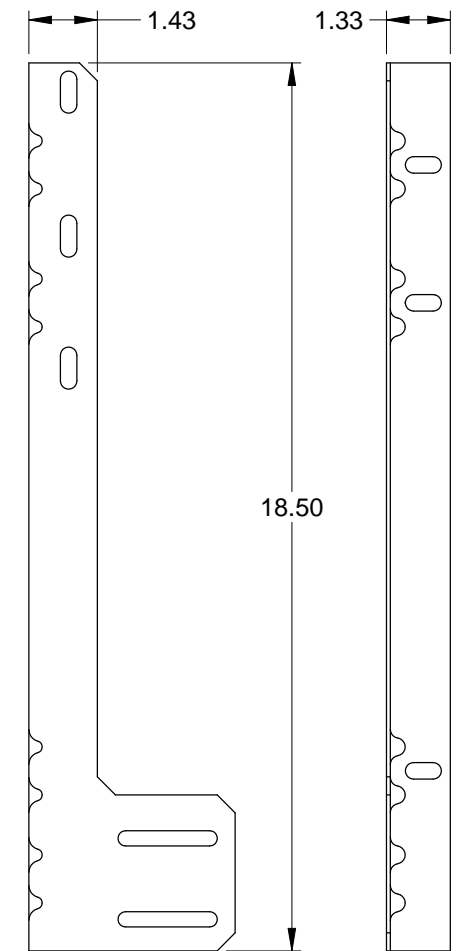

Jamb Angle
.078 Galv. Steel

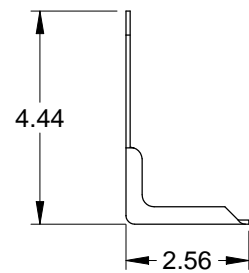

Top Fixture
.086 Galv. Steel

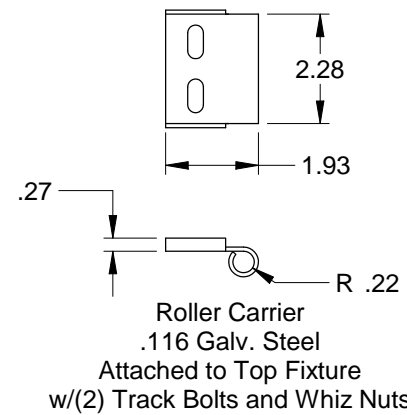
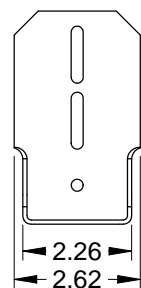

Roller Carrier
.116 Galv. Steel
Attached to Top Fixture
w/(2) Track Bolts and Whiz Nuts

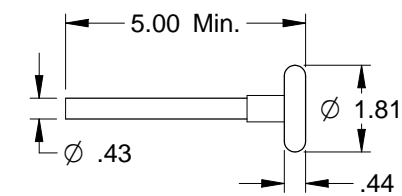

Nylon 11-ball Track Roller (Std.)
Steel 10-ball Track Roller (Opt.)

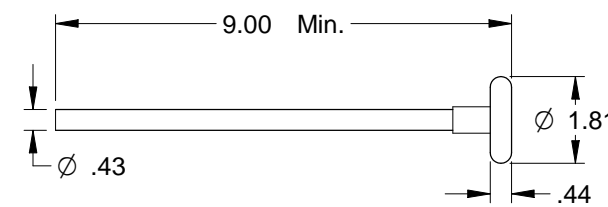

Nylon Precision Bearing Track Roller (Opt.)
Steel 10-ball High Tensile Track Roller (Opt.)

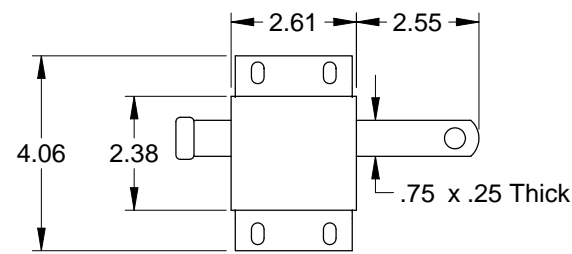

Slide Lock
Case .086 Galv. Steel

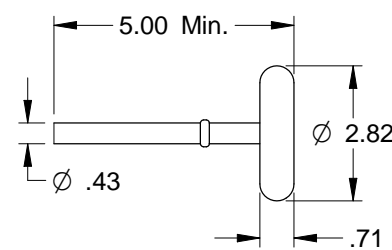

Steel 10-ball Track Roller (Opt.)

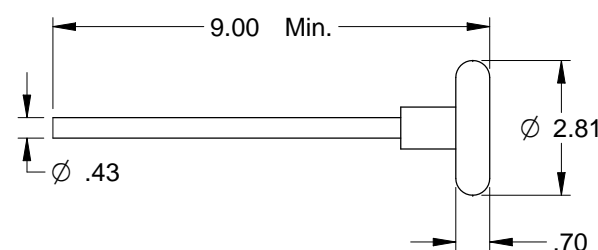

Steel Precision Bearing Track Roller (Opt.)

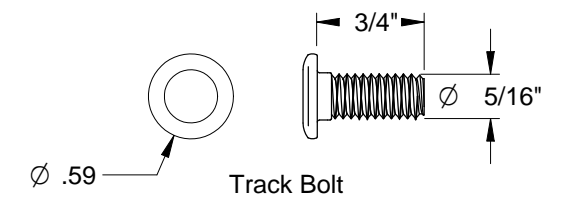

Track Bolt

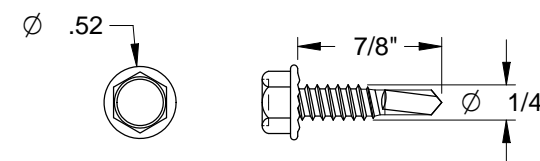

Self-Drilling Screw

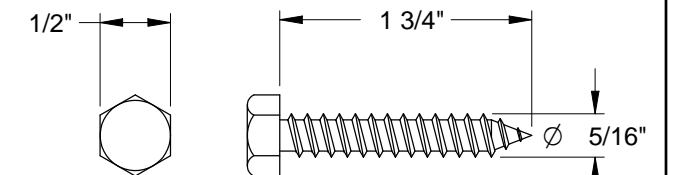

Hex Head Lag Screw

Scott A. Brown, P.E. Lic. No. 65940
Wendler Engineering Services, Inc.
698 Timber Creek Road, Dixon, IL 61021
FBPE CA Lic. No. 31544
Structural Adequacy for Wind Load

Scale: None	 1101 East River Road Dixon, IL 61021	Title: Spec, Wind Load Alumaview - AV300	
Drawn by: R. Frey		No. P-2434	Sheet 3
Checked by: G. Wedekind			Rev A
Date: 03/21/19		ECO: 8132.01	