

TM200C			
Maximum Door Width	Center Hinges per Section	Design Loads	
8'-2"	1	47.5	-53.7
9'-2"	1	42.3	-47.9
10'-2"	2	28.3	-27.7
12'-2"	2	23.7	-23.2
14'-2"	3	17.7	-20.2
16'-2"	3	15.5	-17.7

Scott A. Brown, P.E. Lic. No. 65940
 Wendler Engineering Services, Inc.
 698 Timber Creek Road, Dixon, IL 61021
 FBPE CA Lic. No. 31544
 Structural Adequacy for Wind Load

Printed copies of this document are not considered signed and sealed and the SHA authentication code must be verified on any electronic copies.

Rev.	Description	ECO	Date
B	Added plates, M200C to title, angle mount details and tapcon jamb details. Endstile was 16 ga. Reduced pressures.	8313.02	09/25/20
A	New release for production.	8313.01	12/05/19

Scale: None
 Drawn by: R. Frey
 Checked by: G. Wedekind
 Date: 12/05/19
 ECO: 8313.01

RAYNOR
 1101 East River Road
 Dixon, IL 61021

Title: Spec, Wind Load TM200C / M200C
 No. P-2437
 Sheet 1 of 3
 Rev B

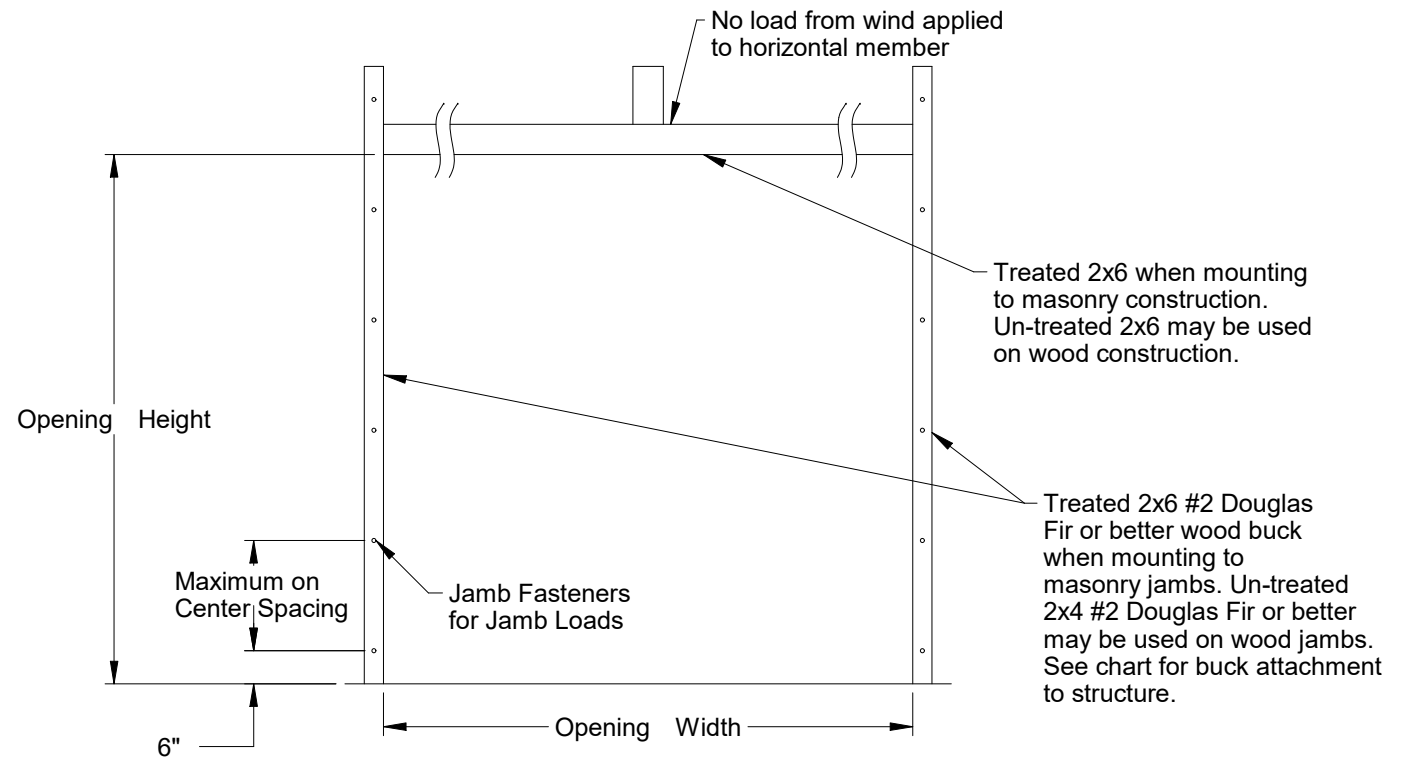
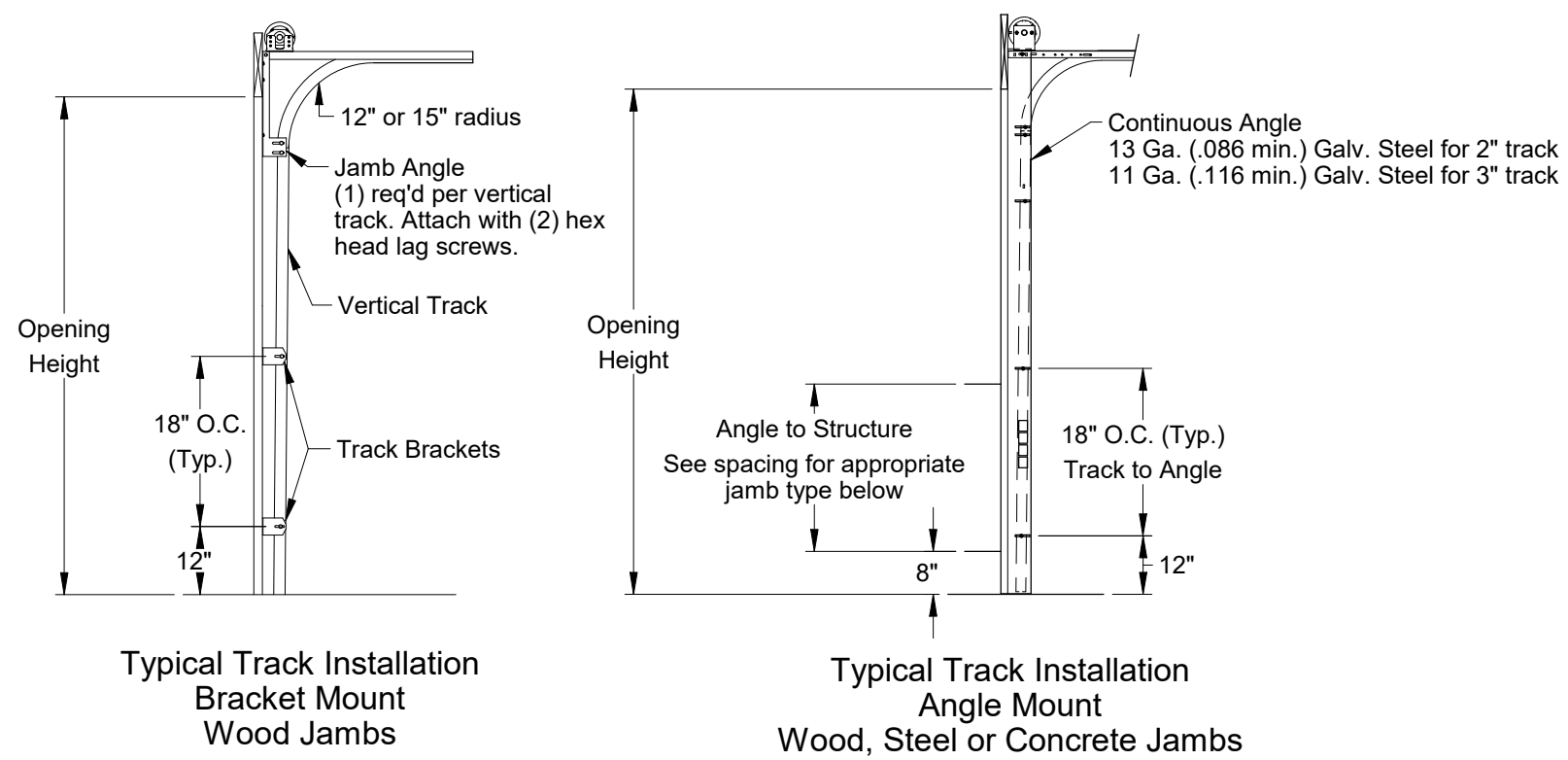

Normal headroom track shown, low headroom, lift clearance and vertical lift track available

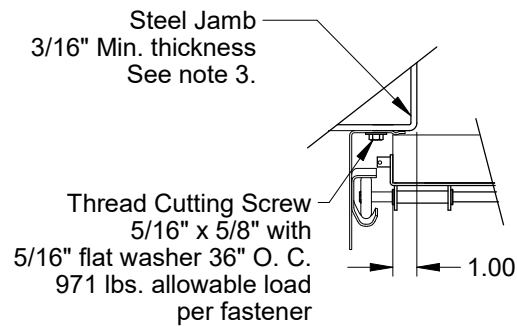

Track Assembly Attachment to Steel Jamb

2\"/>

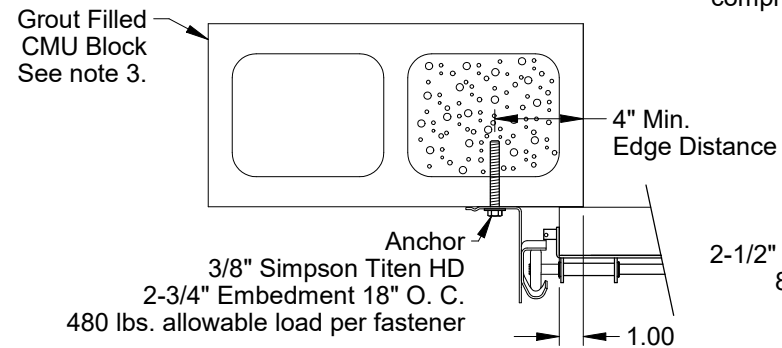

Track Assembly Attachment to Grout Filled CMU Block

2\"/>

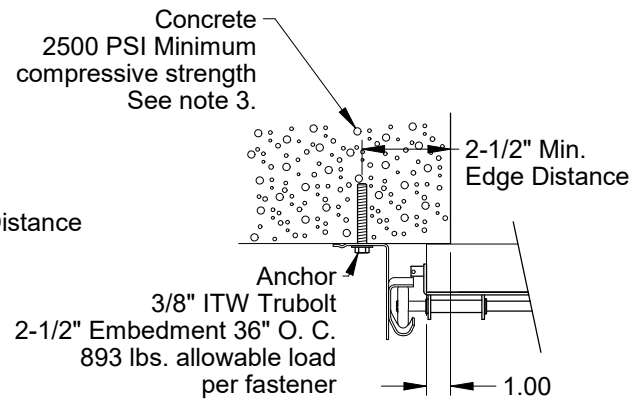

Track Assembly Attachment to 2500 PSI Min. Concrete

2\"/>

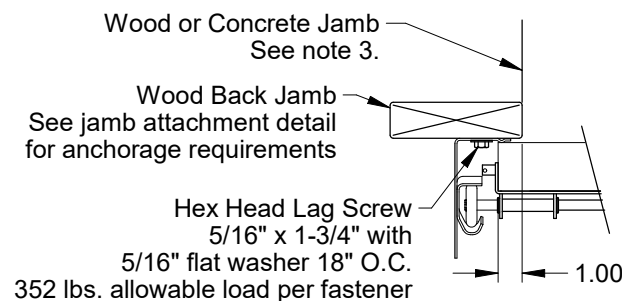

Track Assembly Attachment to Wood Back Jamb

2\"/>

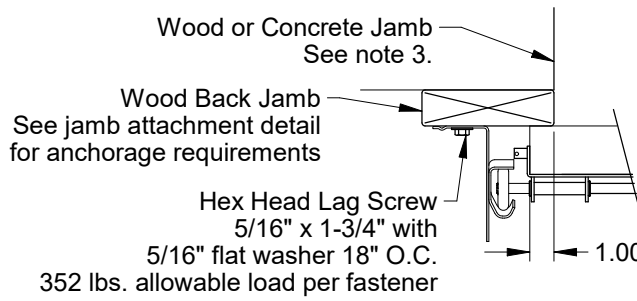

Track Assembly Attachment to Wood Back Jamb

2\"/>

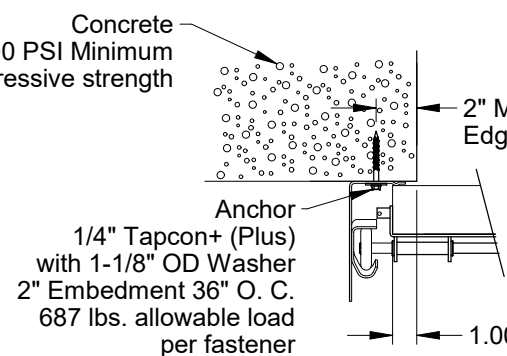

Track Assembly Attachment to 2500 PSI Min. Concrete

2\"/>

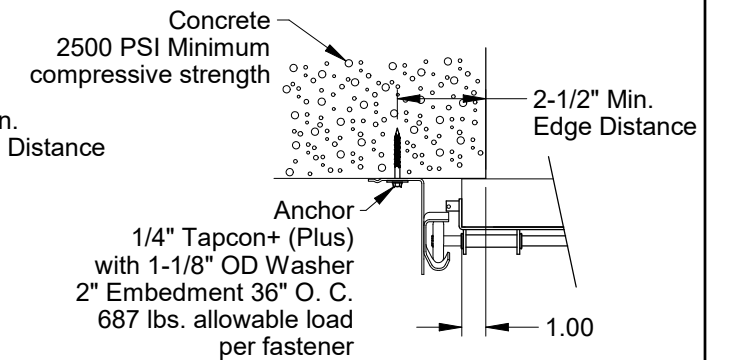

Track Assembly Attachment to 2500 PSI Min. Concrete

2\"/>

Jamb Attachment Notes:

1. Maximum Positive Load per Jamb = (9'-2" x 42.3 PSF) / 2 = 195 lbs. per foot.
2. Maximum Negative Load per Jamb = (9'-2" x -47.9 PSF) / 2 = 221 lbs. per foot.
3. Design of the supporting structure shall be the sole responsibility of the building designer and shall be designed for the jamb loads listed in notes 1 and 2.
4. Alternate jamb attachments may be used if approved by a registered Professional Engineer.
5. DASMA Technical Data Sheet TDS-161 may be used for alternate jamb attachments.
6. 3/8" diameter lag screws required 1/16" pilot hole and 1-1/2" minimum required distance.

2x6 Attachment to Structure						
Structure Type	Fastener Type	Minimum Embedment	Minimum Edge Distance	Minimum on Center Spacing	Maximum on Center Spacing	Allowable Tension Load
2500 PSI Min. Concrete	1/4" Tapcon+ (Plus) with 1-1/8" OD Washer	2"	2.5	6"	24"	526
Southern Pine	3/8" x 3" Lag with 1-1/8" OD Washer	1.50"	1.50"	1.50"	24"	655
Spruce Pine Fir	3/8" x 3" LAG with 1-1/8" OD Washer	1.50"	1.50"	1.50"	24"	482

Scott A. Brown, P.E. Lic. No. 65940
Wendler Engineering Services, Inc.
698 Timber Creek Road, Dixon, IL 61021
FBPE CA Lic. No. 31544
Structural Adequacy for Wind Load

Scale: None
Drawn by: R. Frey
Checked by: G. Wedekind
Date: 12/05/19
ECO: 8313.01



1101 East River Road
Dixon, IL 61021

Title: Spec, Wind Load
TM200C / M200C

No. P-2437	Sheet 2	Rev B
------------	---------	-------

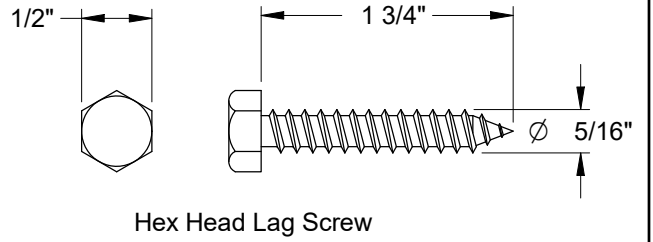
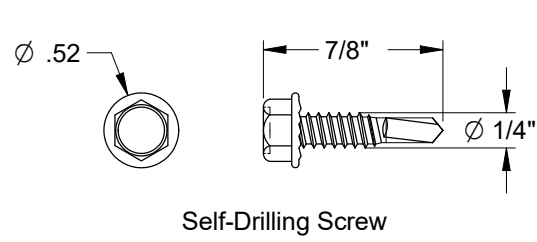
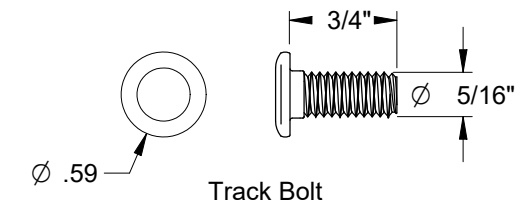
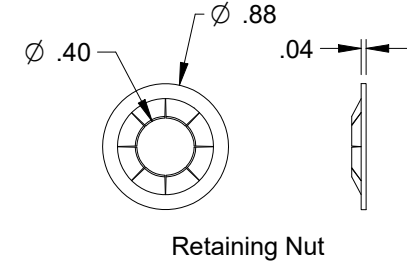
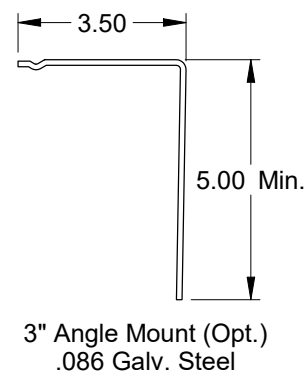
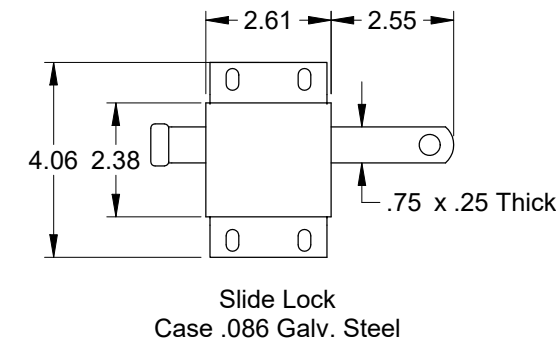
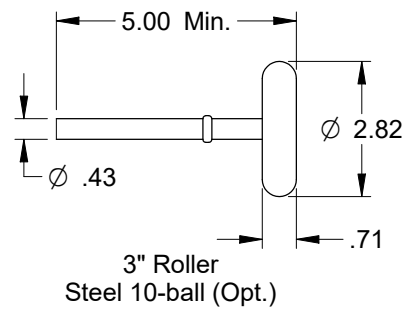
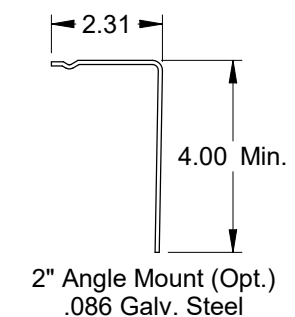
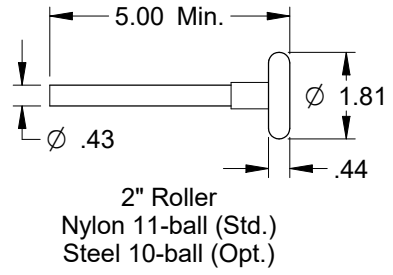
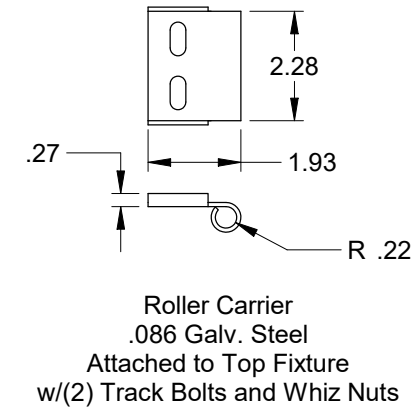
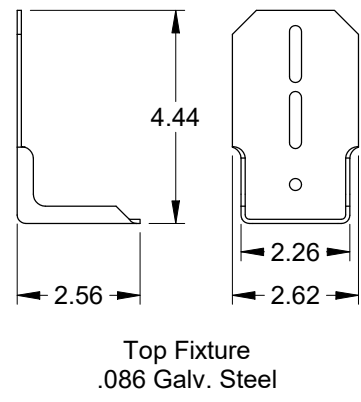
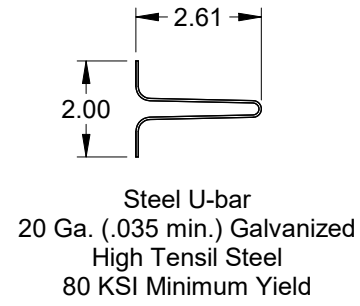
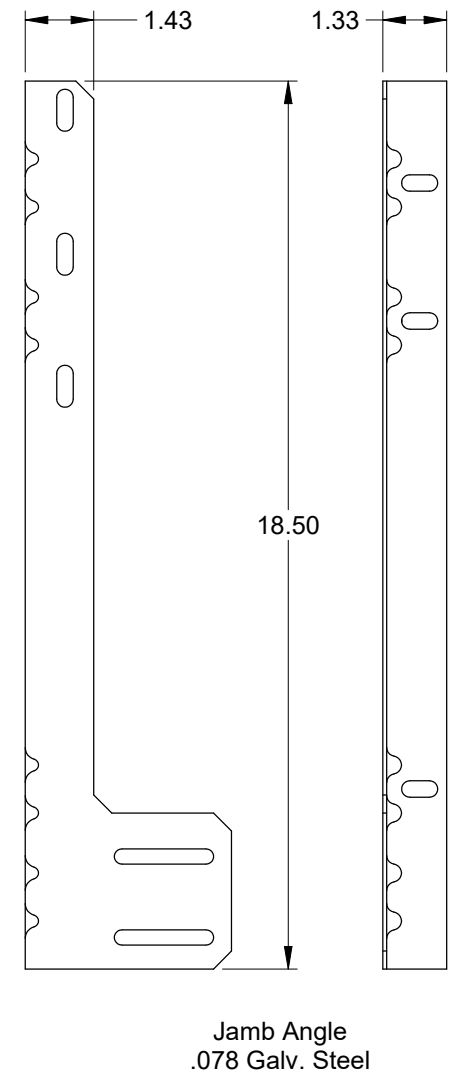
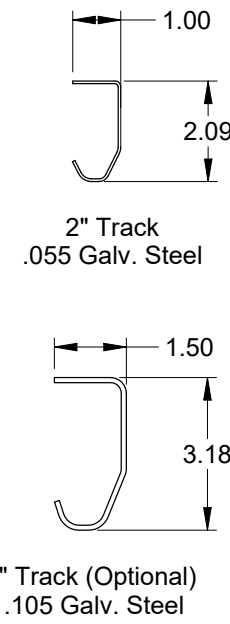
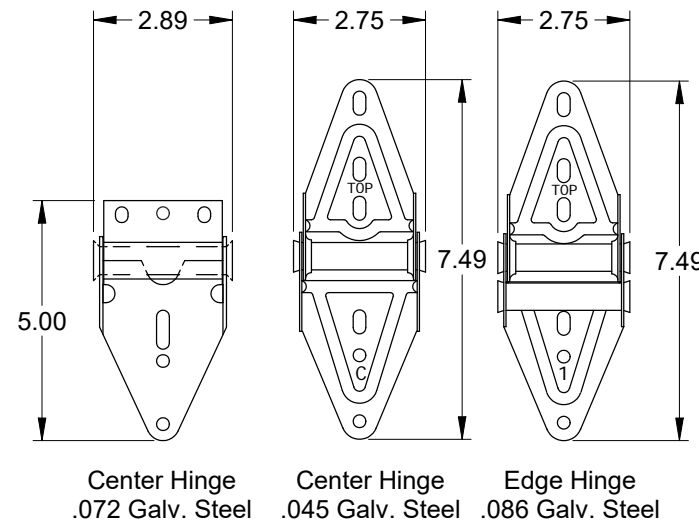
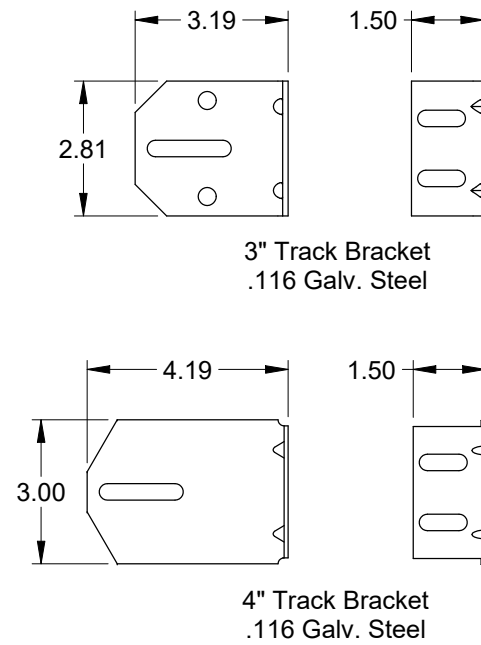
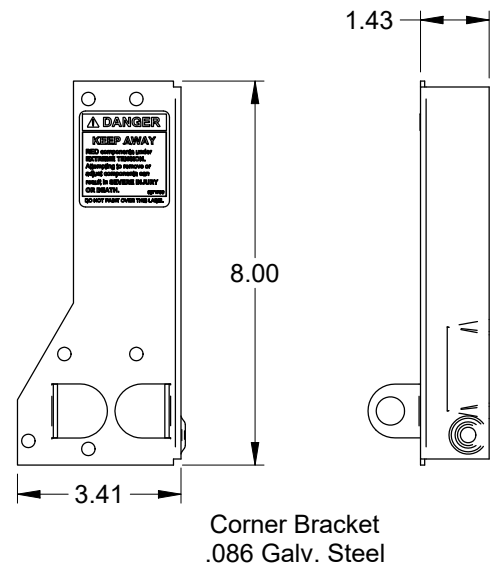

Scott A. Brown, P.E. Lic. No. 65940
Wendler Engineering Services, Inc.
698 Timber Creek Road, Dixon, IL 61021
FBPE CA Lic. No. 31544
Structural Adequacy for Wind Load

Scale: None	<p>1101 East River Road Dixon, IL 61021</p>	Title: Spec, Wind Load TM200C / M200C	
Drawn by: R. Frey		No. P-2437	Sheet 3
Checked by: G. Wedekind			Rev B
Date: 12/05/19		ECO: 8313.01	