



VIPIN N. TOLAT, P.E.
15123 Lantern Creek Lane,
Houston, TX. 77068-3831
TEL: 281-444-9183
Fax: 281-444-9184
Email: vtolat@sbcglobal.net

*Engineering - Inspections
& Product Approvals*

Page 1

ENGINEER'S EVALUATION REPORT # NU0413C dated 10/30/2020

CATEGORY: Structural Components
SUB CATEGORY: Metal Connectors

REPORT HOLDER:

NuVue Industries Inc;
1055 E. 29th Street,
Hialeah, FL. 33013
www.nu-vueindustries.com
nuvue@bellsouth.net
Phone: 305-694-0397
Fax: 305-694-0398

1.0 EVALUATION SCOPE:

Compliance with 2020 Florida Building Code- Building and Residential

2.0 PRODUCT DESCRIPTION:

Refer to tables 1 through 21 of this report for Product name, size, size and number of fasteners, fastening details shown in the diagrams and the allowable loads.

3.0 STRUCTURAL SPECIFICATIONS :

1. Steel shall conform to ASTM A653, SS grade 33, min. yield 33 ksi, min. tensile strength 45 ksi and min. galvanized coating of G 60 per ASTM A653.
2. Allowable loads and fasteners are based on NDS 2018.
3. Design loads are for S. Pine, specific gravity 0.55. Design loads for other species shall be adjusted per NDS 2018.
4. Allowable uplift loads have been adjusted for load duration factor CD of 1.6. Allowable gravity loads have been adjusted for CD values of 1.0, 1.15 and 1.25 per NDS 2018. Design loads do not include 33% increase for steel and concrete.
5. Concrete in Tie beams shall be min. of 2500 psi. Concrete Masonry, Grout and mortar in concrete masonry shall be min. of 1500 psi. Concrete masonry shall comply with ASTM C90.
6. Combined load of Uplift, L1 and L2 shall satisfy the following equation.

$$\frac{\text{Actual Uplift}}{\text{Allowable Uplift}} + \frac{\text{Actual L1}}{\text{Allowable L1}} + \frac{\text{Actual L2}}{\text{Allowable L2}} \leq 1.0$$

4.0 INSTALLATION

Installation shall be in accordance with this report and the latest edition of Nu-Vue Industries Catalog. The information in this report supercedes any conflicting information in the catalog.

5.0 EVIDENCE SUBMITTED:

Test reports submitted by Product testing Inc, (PT) Atec Associates Inc(Atec) and PSI Inc and signed and sealed calculations in conformance with FBC 2020 by Vipin N. Tolat, P.E. Tests conducted do conform to ASTM D 1761-2006, ASTM D7147-2011 and AISI S100-2016 and calculations for design loads conform to NDS 2018.

Product tested	Test #/Test lab	Date Tested
NVTA/NVTAS	02-3938/PT	8/6/02
NVTA/NVTAS	02-4073/PT	11/6/02
NVTA/NVTAS	02-4074/PT	11/6/02
NVTA/NVTAS	02-4075/PT	11/6/02
NVTA/NVTAS	31.22456.0002/ATEC	7/6/02
NVBH 24	02-4096/PT	12/3/02
NVUH 26	02-4095/PT	1/17/03
NVRT	03-4177/PT	2/3/03
NVRT	03-4202/PT	2/19/03
NVRT	03/4270,4271/PT	3/27/03
NVTH/NVTHS	04-4698/PT	4/15/04
NVSNP3	03-4482/PT	9/15/03
NV358	03/4543/PT	12/19/03
NV458	03-4590/PT	12/31/03
NVHCL/R	03-4625/PT	1/21/04
NVSTA/NVHTA/NVSTA-H/NVHTA-H	04-4641,4642/PT	3/17&3/22/04
NVJH24,26,28	03-4385,86,87/PT	5/30/03
NVSO236	03-4349,57,58/PT	5/13,5/19,5/20/03
NVTP4	03-4303,44/PT	4/21, 5/1/03
NVTP4H	03-4345,43/PT	5/2, 5/5/03
NVHC43,43/2	70-02-94-00381/ATEC	11/27/95
AB5	05-5195,95A/PT	2/15/08
AB7	05-5196,96A/PT	2/15/08
NVHC37	03697.0001/ATEC	11/27/96
IKE1	05-5612/PT	3/20/06

IKE2	06-5622/PT	5/1/06
NVTHJ26	04-4995/PT & 138-96013-01/PSI	1/31/05 & 2/7/89
NVTHJ28	04-4996/PT & 138-96013-05/PSI	1/31/05 & 12/2/89
NVHGA10	11041/FTL	7/6/2020
NVWS	12272/FTL	8/26/2020
NVTT	03-4631/PT	6/21/2004
NVTT	04-4908/PT	7/21/2004

6.0 DESIGN:

- 1 Maximum allowable loads shall not exceed the allowable loads listed in this report. Allowable loads are based on allowable stress design per NDS.
2. Capacity of wood members is not covered by this report. Allowable loads shall not exceed the capacity of wood members. Capacity of wood members shall be checked by Engineer/Architect of record.
3. Wood members with which the connectors are used must be nominal dimension lumber or approved structural composite lumber.

7.0 CODITIONS OF USE:

1. NuVue Industries metal structural connectors described in this report comply with or are suitable alternative to what is specified in section 1.0 of this report.
2. Design loads must be less than the allowable loads shown in all the tables of this report.
3. The connectors must be manufactured, identified and installed in accordance with this report and the manufacturer's instructions.
4. Products covered by this report are manufactured by NuVue industries Inc in Hialeah, Florida under a quality control program with inspections by NAMI Inc having State of Florida license # QUA 1789.



Vipin N. Tolat, P.E.
Florida P.E. # 12847
10/30/2020

vnt/nu0413C

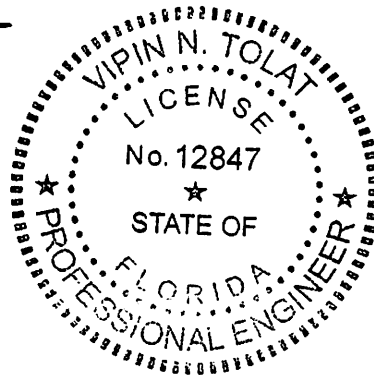

18 Gauge Angle Clips.

Table 1

Product Code	Dimensions (inches)			Fastener Schedule		Allowable Loads (lbs)	
	W1	W2	L	Header	Joist	F1	F2
AB5	1½"	2⅝"	5	3-10dx1½"	3-10dx1½"	511	595
AB7	1½"	2⅝"	7	4-10dx1½"	4-10dx1½"	582	794

Notes: Nail wider angle leg to Joist and Shorter leg to Header.

CD = 1.6 for F1 & F2.

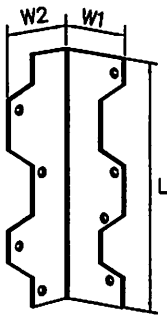

AB-7

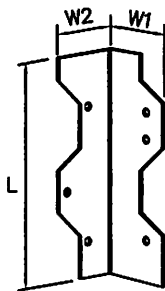

AB-5

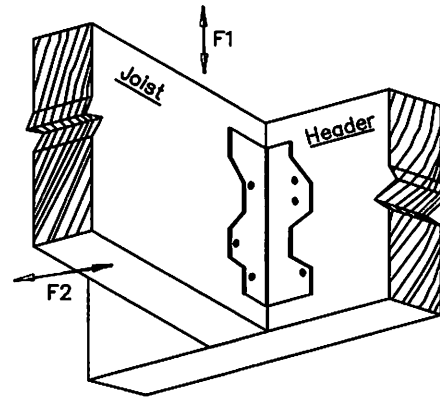

Typical Installation

18 Gauge NVHC 37 5WAY Grip Clips (520)

Table 2

Product Code	Description	Nail Schedule		Allowable Design Loads (lbs)		
		Header or Plate	Joist or Stud	Uplift	L1	L2
NVHC 37	5 Way Clip	16-8d or 16-10d	12-8d or 12-10d	702	560	637

CD = 1.6 for F1 & F2.

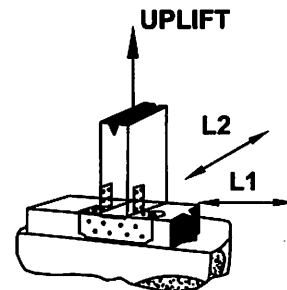
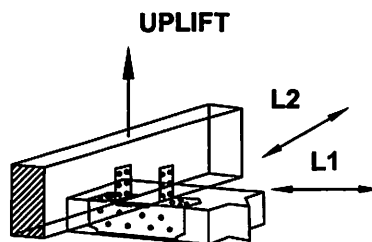
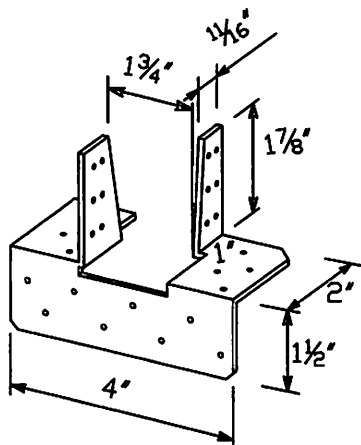

Deep Seat Truss Anchor. They are designed to resist lateral and uplift forces. The strap is made of 14 gauge steel and the seats of 20 gauge steel.

Table 3

Assembly Product Code	Dimension H (Inches)	Total No. of Fasteners in Strap 10d x 1½"	Total No. of Fasteners in 20 GA. Seat 10d x 1½"	Allowable Loads (lbs) F'c = 2500 psi		
				Uplift	L1	L2
NVSTA12	12	5	6	1046	700	1049
		6	6	1141	760	1144
NVSTA16	16	7	6	1236	823	1239
		8	6	1331	887	1335
NVSTA22	22	9	6	1426	950	1430
NVSTA24	24					

CD = 1.6 for L1 & L2.

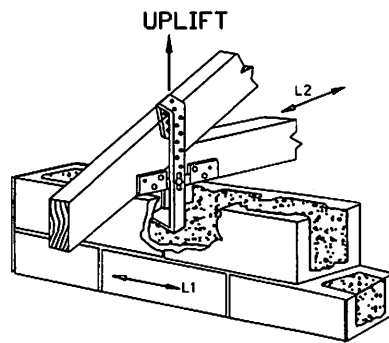

NVSTA

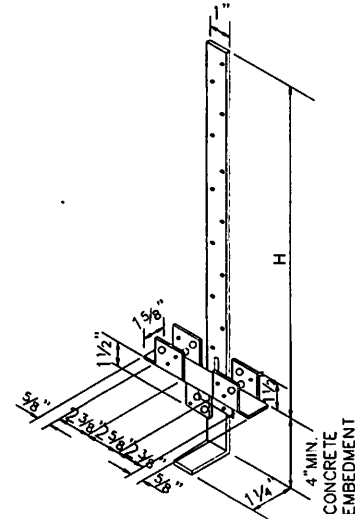

Holden Double Strap Riveted Truss Anchor. They are designed of 14 gauge steel plates to resist lateral and uplift forces. The seats are made of 20 gauge steel.

Table 4

Assembly Product Code	Dimension H (inches)	Total No. of Fasteners in two Straps 10d x 1½"	Total No. of Fasteners in 20 GA. Seat 10d x 1½"	Allowable Loads (lbs) F'c = 2500 psi (unless otherwise noted)			
				Uplift	Uplift F'c = 3000 psi	L1	L2
NVHTA12	12	10	6	1506	1766	1050	1450
		12	6	1695	1987	1181	1631
NVHTA16	16	14	6	1883	2208	1312	1812
		16	6	2071	2429	1444	1994
NVHTA22	22	18	6	2259	2649	1575	2175
NVHTA24	24						

CD = 1.6 for L1 & L2.

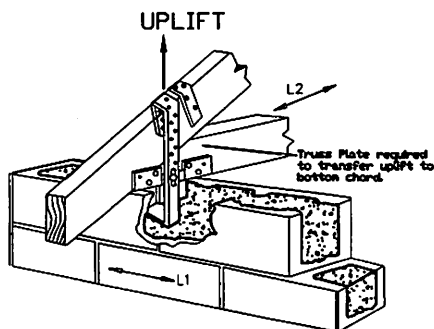

NVHTA

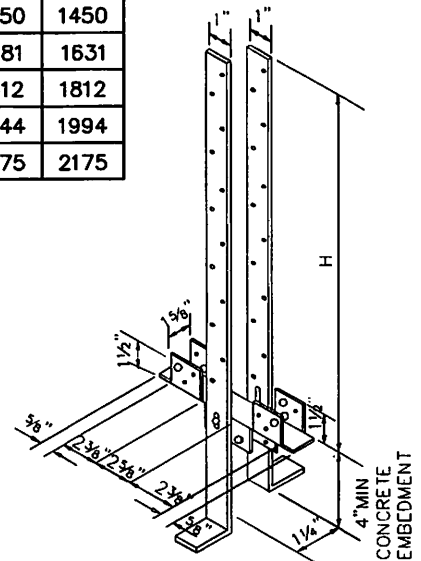

12 Gauge NVTHJ Truss Hip & Jack Hanger

Table 5

Product Code	Allowable Loads (lbs) S. Pine				Nail Schedule						
	Uplift Loads 160%	Gravity			Header Nails 16d (e)	Hip Nail 10d			Jack Nail 10d		
		100%	115%	125%		a	b	total	c	d	total
NVTHJ26	1478	2444	2444	2444	16	4	3	7	2	3	5
NVTHJ28	1931	3229	3333	3333	20	5	4	9	2	3	5

Note: For 1-2x members 10d x 1 1/2" nails can be used

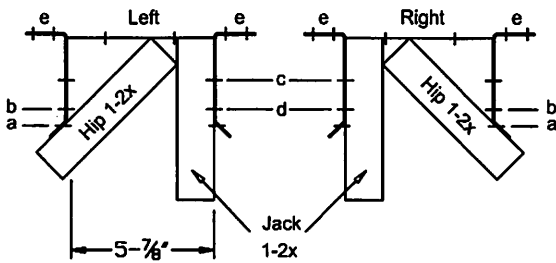

20G Stud Plate Ties

Table 6

Product Code	Dimensions (inches)			Fasteners		Allowable Loads (lbs)		
	W	H	L	Stud	Plate	Uplift	L1	L2
IKE 1	1 1/2	5	3 1/2	6-10d	4-10d	787	337	337
IKE 2	1 1/2	6 5/8	3 1/2	6-10d	7-10d	932	451	318

CD = 1.6 for L1 & L2.

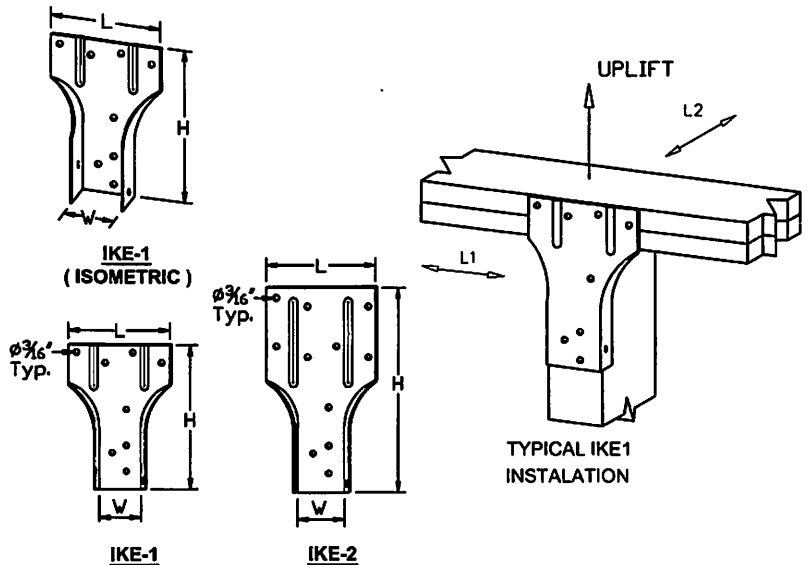
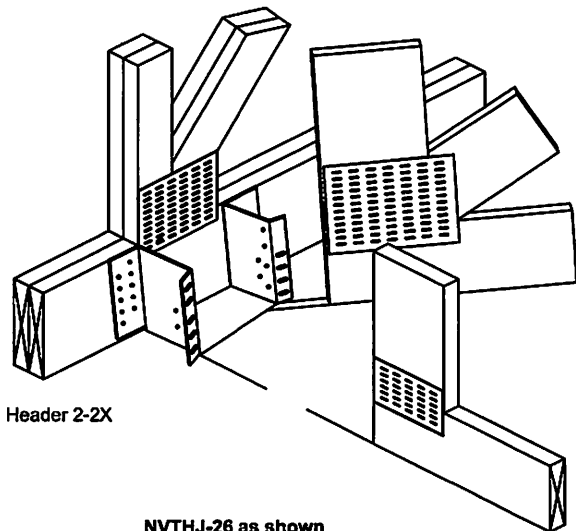
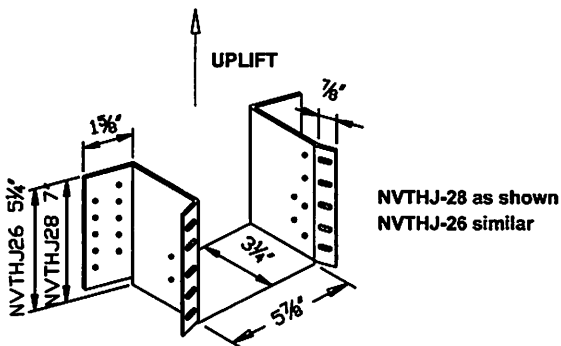

U.S. Patent No. 4,964,253

18 Gauge NVTT Sanibel Truss Strap

Table 7

Product Code	Dimensions (inches)				Fasteners Schedule			Allowable Loads (lbs)	
	W	B	H	L	Truss	Top Plates	Hollow Concrete Masonry	Uplift	L1
NVTT-1	1 $\frac{5}{16}$	1 $\frac{3}{4}$	14	13	2-10dx1 $\frac{1}{2}$ "	6-10d	---	983	543
NVTT-2	1 $\frac{5}{16}$	1 $\frac{3}{4}$	14	13	2-10dx1 $\frac{1}{2}$ "	---	6- $\frac{1}{4}$ " ϕ x1 $\frac{1}{2}$ " Tapcons	1584	465

1. 1-10dx1 $\frac{1}{2}$ " nail is placed on each side of the Truss and 3-10dnails in each leg are placed in two top plates.
2. 3- $\frac{1}{4}$ " dia. x 1 $\frac{1}{2}$ " long, 1 $\frac{1}{4}$ " embedment tapcons are placed in each leg and into the hollow concrete masonry. Maintain 2 $\frac{1}{2}$ " edge distance from top of the block and spacing of 3" between the tapcons.

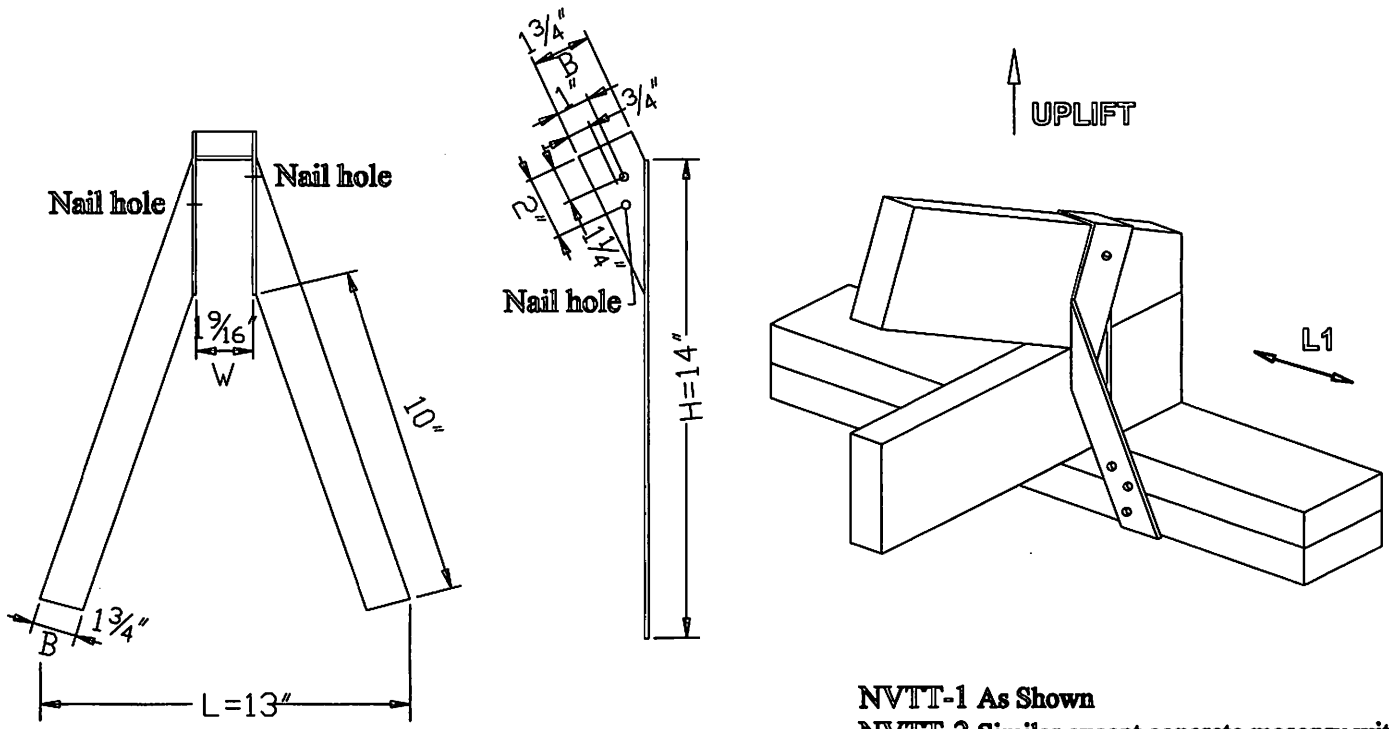

NVTT 1 and 2

NVTT-1 As Shown
NVTT-2 Similar except concrete masonry with tapcon anchors instead of Wood Plates and nails.

Table 8

Truss Anchors NVTA and Riveted Truss Anchors with Seat NVTAS
14 G Straps, 20 G Seats

H Length (in)	Product Code	
16	NVTA-16	NVTAS 212
18	NVTA-18	NVTAS 214
20	NVTA-20	NVTAS 216
22	NVTA-22	NVTAS 218
24	NVTA-24	NVTAS 220
26	NVTA-26	NVTAS 222
28	NVTA-28	NVTAS 224
30	NVTA-30	NVTAS 226
36	NVTA-36	NVTAS 232
48	NVTA-48	NVTAS 244

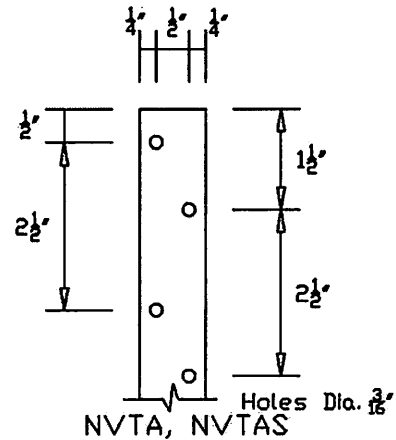
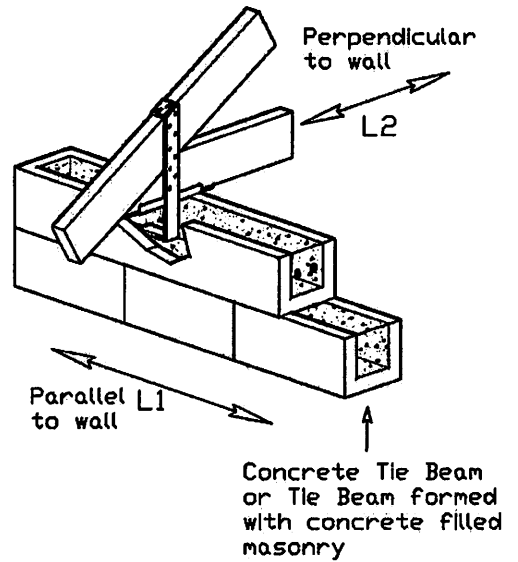
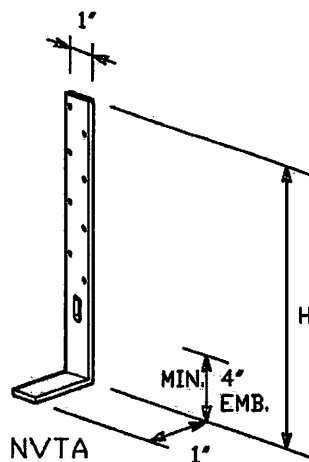
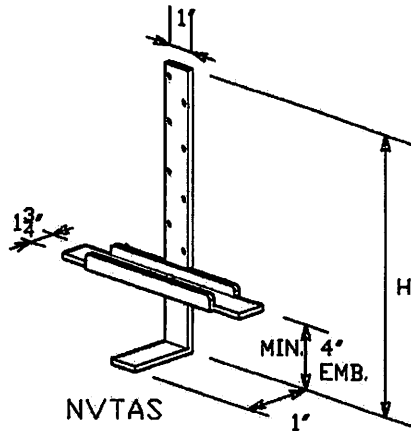

No. of Fasteners each strap 10d	Maximum Allowable Load (lbs)			
	Uplift Single Strap	Uplift Double Straps	L1 Single & Double Straps	L2 Single & Double Straps
5	757	1514	250	500
6	805	1610	250	500
7	854	1708	250	500
8	902	*1804	250	500
9	951	*1902	250	500
10	999	*1998	250	500
11	1048	*2096	250	500
12	1096	*2192	250	500
13	1145	*2290	250	500
14	1193	*2290	250	500

No. of Fasteners each strap 10d x 1.5"	Maximum Allowable Load (lbs)			
	Uplift Single Strap	Uplift Double Straps	L1 Single & Double Straps	L2 Single & Double Straps
5	1032	2236	250	500
6	1127	2254	385	565
7	1136	2272	520	630
8	1144	*2288	520	630
9	1153	*2306	520	630
10	1161	*2322	520	630
11	1170	*2340	520	630
12	1178	*2356	520	630
13	1187	*2374	520	630

*Note: For 8 or more nails per strap, use double truss for double straps.

TABLE 9
NVBH 24 BUTTERFLY HANGER

SIZE	PRODUCT CODE	GAUGE	FASTENER SCHEDULE		ALLOWABLE LOADS (lbs.)	
			HEADER 8d	JOIST 8d	DOWNWARD GRAVITY LOADS $C_D=1.0$	WIND ² UPLIFT LOAD $C_D=1.6$
2x4	NVBH24	18	12	6	1113	364

Notes:

1. Values are based on $1\frac{1}{2}$ " header and Joist thickness.
2. Can only be used in Non-HVHZ.

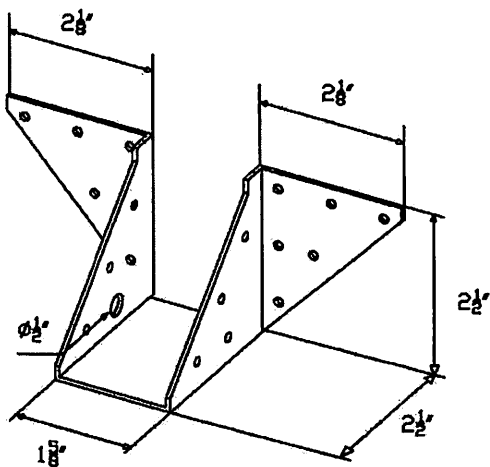
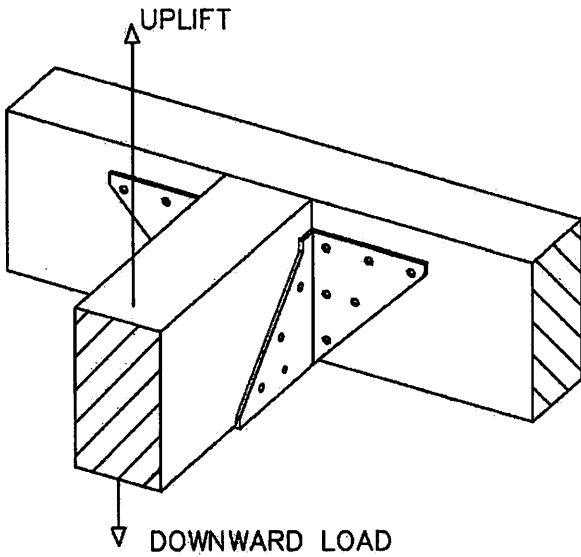

TABLE 10
NVUH 26 JOIST HANGER

SIZE	PRODUCT CODE	GAUGE	FASTENER SCHEDULE		ALLOWABLE LOADS (lbs.)	
			HEADER 16d	JOIST 10d x 1 1/2"	DOWNWARD GRAVITY LOADS $C_D=1.0$	WIND UPLIFT LOAD $C_D=1.6$
2x6	NVUH26	14	20	10	2233	1213

Notes:

1. Values are based on 3" header thickness and $1\frac{1}{2}$ " Joist thickness.

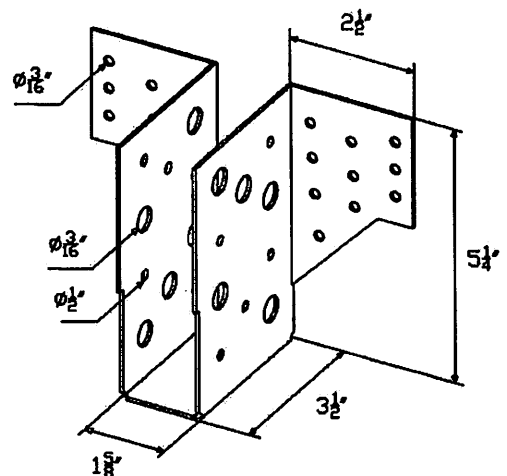
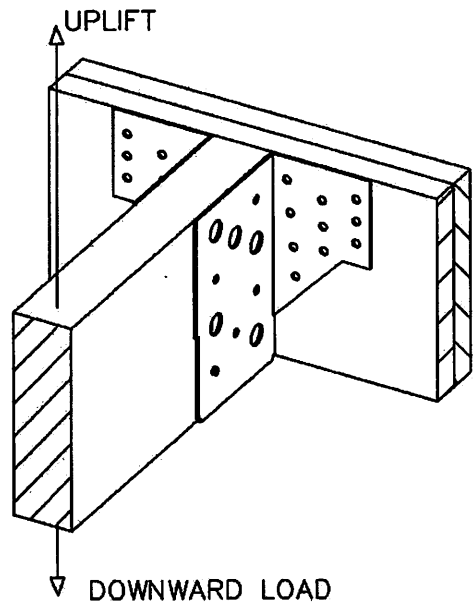

TABLE 11
NVRT Flat and Twisted Rafter Ties 1"X14 G

Length (in)	Product Code	Gauge
12	NVRT-12	14
16	NVRT-16	14
18	NVRT-18	14
20	NVRT-20	14
22	NVRT-22	14
24	NVRT-24	14
30	NVRT-30	14
36	NVRT-36	14
48	NVRT-48	14

NVRT Wood to Wood

16d Fasteners or 10dx1½"		Maximum Uplift Load (lbs)	
TOTAL	In each member*	Flat Ties	Twisted Ties
6	3	588 ⁵	588 ⁵
8	4	725	724
10	5	861	860
12	6	998	996
14	7	1135	1132

NVRT Wood to Concrete

No. of 16d nails to Wood Framing	No. of ¼" diameter Tapcons to Concrete	Maximum Uplift Load (lbs)
3	3	588 ⁵
4	4	722
5	4	856
6	5	991
7	5	1125

Notes:

1. Specify "F" for Flat and "T" for Twisted when ordering.
2. Fastener values are based on a minimum 1½" thick wood members.
3. * Indicates no. of nails in each connected wood member.
4. ITW tapcons shall be embedded a minimum of 1¼" into the concrete tie beam formed with concrete filled masonry. ITW tapcons shall have a minimum edge distance of 2½" and minimum staggered spacing of ¾" as shown.
5. Use only in Non-HVHZ.
6. For Uplift loads $C_p=1.6$

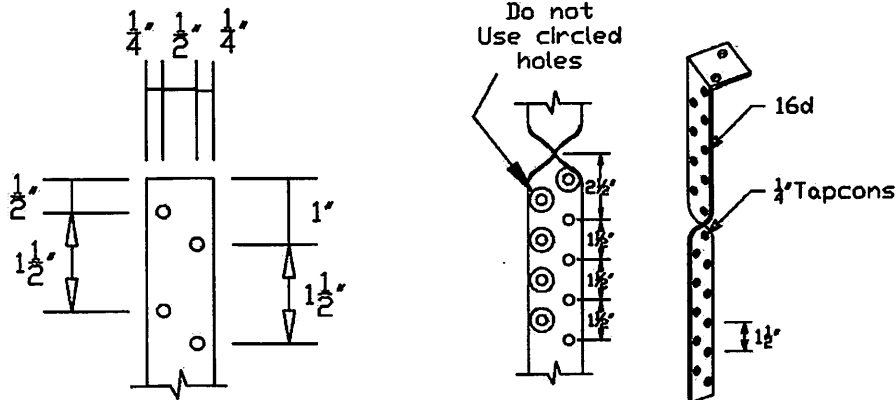

NVRT Anchor
 Holes dia. $\frac{3}{16}$ "

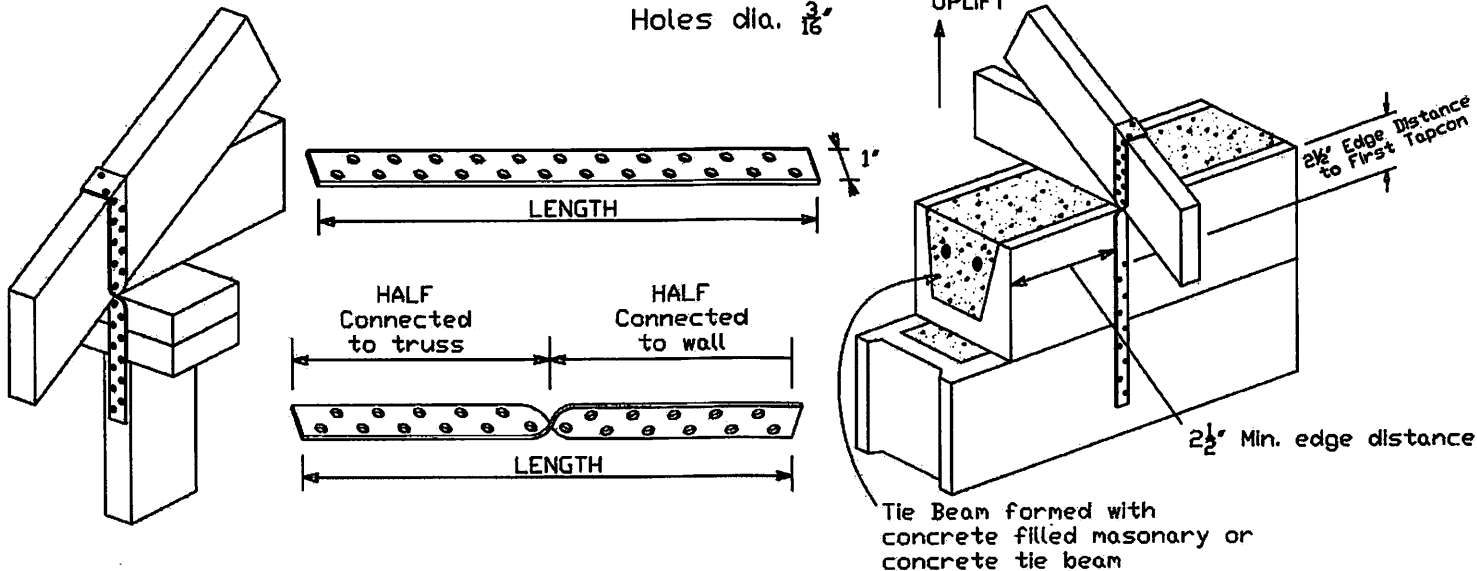

TABLE 12

Truss Anchors NVTH 1¼"x14G, Seat 18G

H Length (in)	Product Code		No. of Fasteners in each Strap 10d x 1.5"	Maximum Uplift Loads (lbs)		Maximum Lateral Loads (lbs)			
				Single Strap on Single Truss	Double Straps on Double Truss	Single Strap		Double Straps	
						L1	L2	L1	L2
12	NVTH-16	NVTHS-212							
14	NVTH-18	NVTHS-214	5	1032	2064	560	525	1120	1050
16	NVTH-20	NVTHS-216	6	1222	2444	671	630	1342	1260
18	NVTH-22	NVTHS-218	7	1275	2550	783	735	1566	1470
20	NVTH-24	NVTHS-220	8	1329	2658	783	735	1566	1470
22	NVTH-26	NVTHS-222	9	1383	2766	783	735	1566	1470
24	NVTH-28	NVTHS-224	10	1437	2874	783	735	1566	1470
26	NVTH-30	NVTHS-226	11	1490	2980	783	735	1566	1470
32	NVTH-36	NVTHS-232	12	1544	3088	783	735	1566	1470
44	NVTH-48	NVTHS-244	13	1598	3196	783	735	1566	1470

C_D=1.6 for Uplift and Lateral loads.

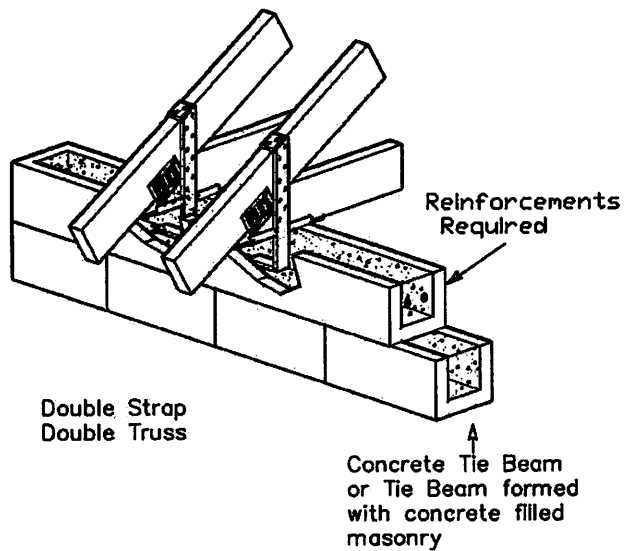
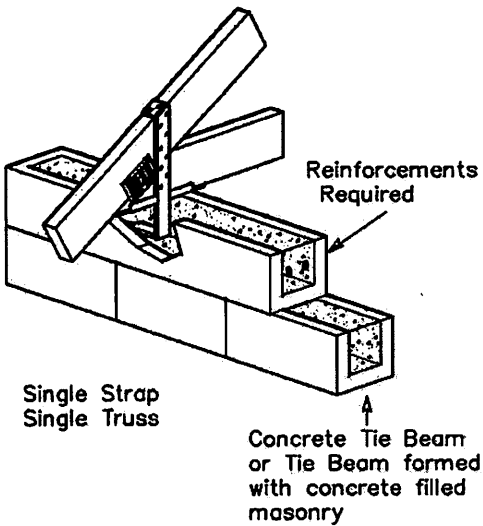
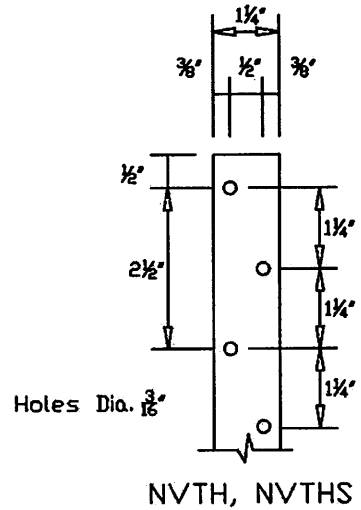
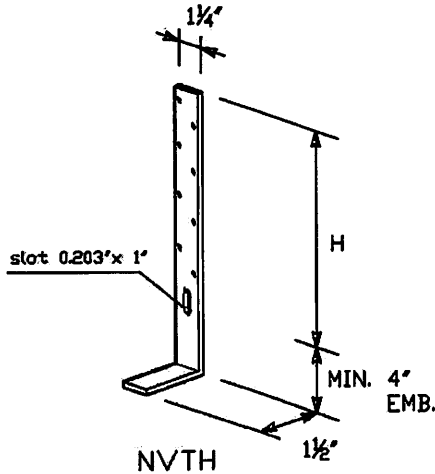
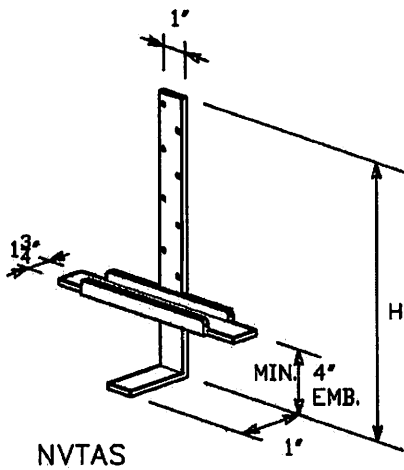

TABLE 13
JOIST SUPPORTS

18 G NVJH JOIST SUPPORTS										Allowable Loads (lbs)		
Product Code	Dimension (Inches)			Joist Size	Double Header Size	Single Header Size	Fasteners			Gravity Loads 100% Uplift Loads 160%		
	W	H	BS				Double Header	Single Header	Joists	Double Header	Single Header	Single & Double Headers
NVJH24	1 5/8	3 5/8	3	2x4 2x6	2-2x4 2-2x6	2x4 2x6	6-10d	6-10d x 1 1/2"	4-10d x 1 1/2"	774	774	493*
NVJH26	1 5/8	5	3	2x6 2x8	2-2x6 2-2x8	2x6 2x8	10-10d	10-10d x 1 1/2"	6-10d x 1 1/2"	1290	1290	821
NVJH28	1 5/8	6 3/4	3	2x8 2x10 2x12	2-2x8 2-2x10 2-2x12	2x8 2x10 2x12	14-10d	14-10d x 1 1/2"	7-10d x 1 1/2"	1806	1806	1079

* Use only in non-HVHZ

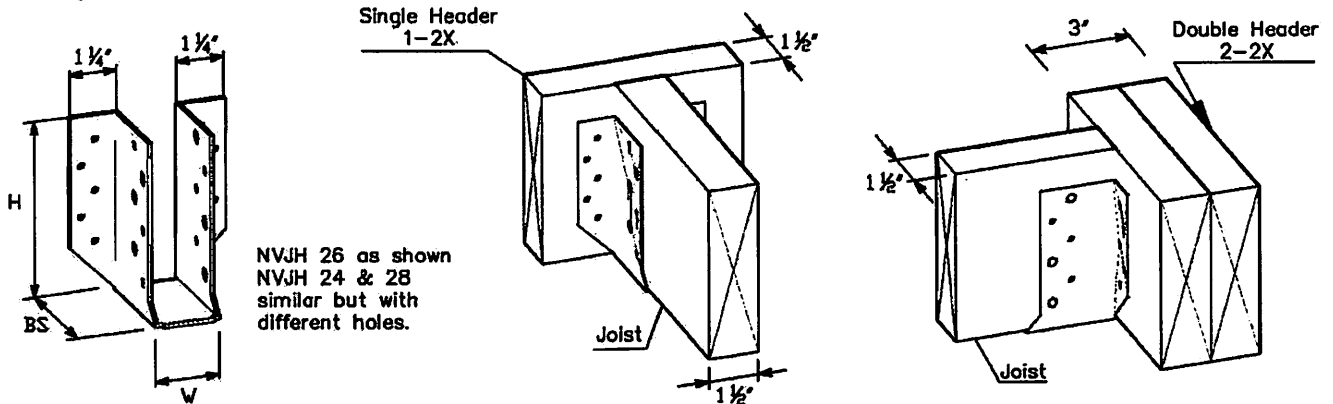

TABLE 14
NVSO 236, 16 GAUGE, HEAVY DUTY
FACE MOUNT JOIST HANGER

Joist Size	Header Size	Fasteners		Allowable Loads (Lbs.)	
		Header	Joist	GRAVITY 100%	Uplift 160%
2x6-8	2-2x8 2-2x10 2-2x12	14-10d	6-10d	1688	1064
		14-16d	6-16d	1800	1228
		4-3/8" x 3" Leg Screws	6-16d	1228	1168

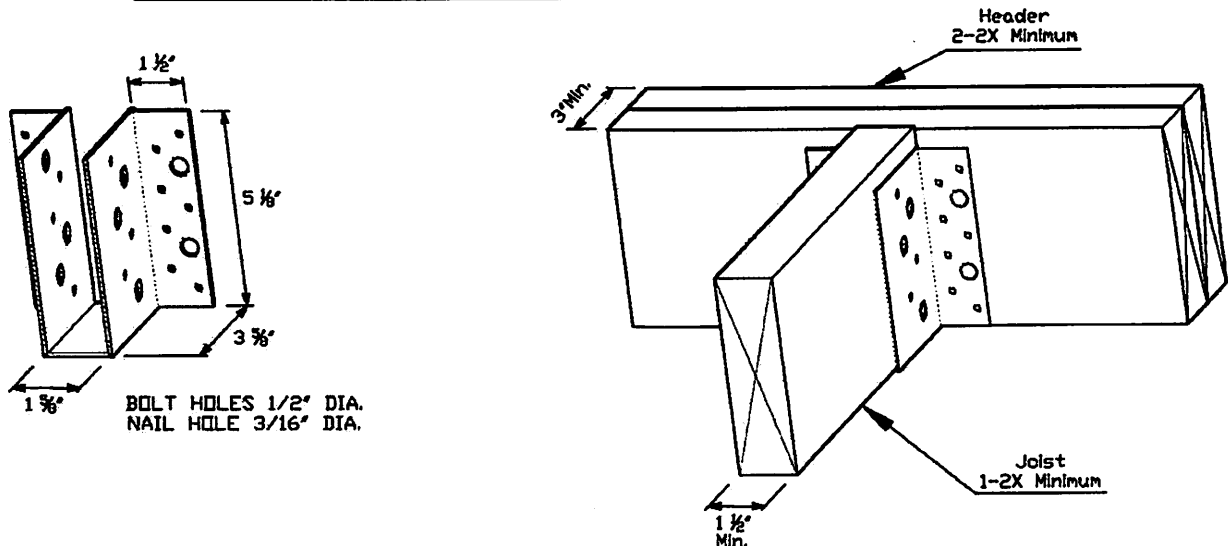
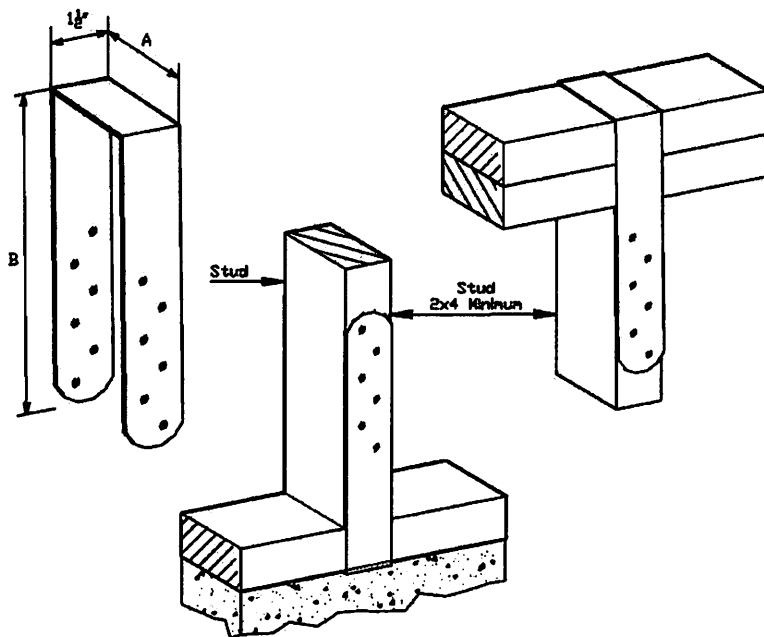

TABLE 15
TOP PLATE ANCHORS
NVTP & NVTPH

Size	Product Code	Gauge	Dimensions (in)	
			A	B
2x4/4x4	NVTP4	20	3 $\frac{5}{8}$ "	8"
2x6/4x6	NVTP6	20	5 $\frac{5}{8}$ "	8"
2x8/4x8	NVTP8	20	7 $\frac{3}{8}$ "	8"
2x4/4x4	NVTP4H	18	3 $\frac{5}{8}$ "	8"
2x6/4x6	NVTP6H	18	5 $\frac{5}{8}$ "	8"
2x8/4x8	NVTP8H	18	7 $\frac{3}{8}$ "	8"

Product code	Total number of fasteners 10d x 1 $\frac{1}{2}$ " Max. Uplift Capacity (lbs)			
	6	8	10	12
NVTP 4,6,8	828	1087	1346	1605
NVTP 4H,6H,8H	938	1207	1476	1745



Notes:

1. One half of all specified fasteners shall be used on each side of the stud to achieve tabulated values.
2. $C_D=1.6$ for Uplift.

TABLE 16
18 Gauge NVHC 43 & NVHC 43/2 HURRICANE CLIP.

PRODUCT CODE	DESCRIPTION	FASTENERS		DESIGN LOADS (LBS)		
		HEADER	JOIST	UPLIFT	L1	L2
NVHC 43	Hurricane Clip - Wide	9-10d	9-10d	687*	407	308
NVHC 43/2	Hurricane Clip - Widex2	10-10d	10-10d	917	547	432

* For Uplift, use two clips, one on each side to comply with section 2321.7 of the FBC

$C_D=1.6$ for Uplift L1 & L2.

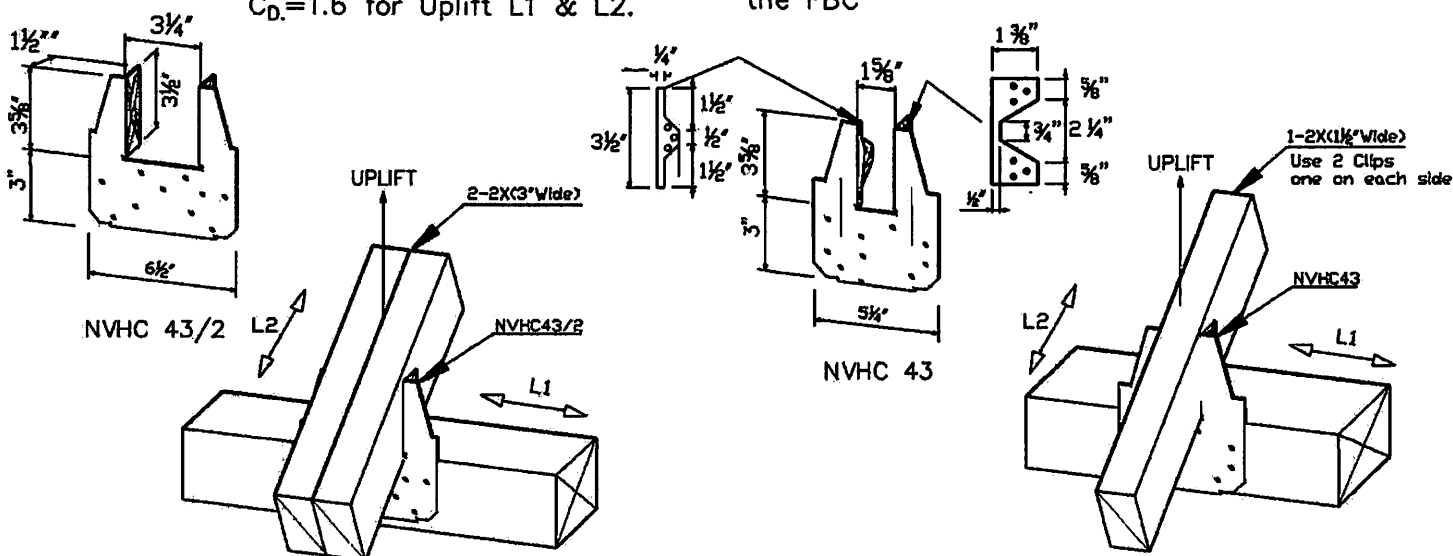
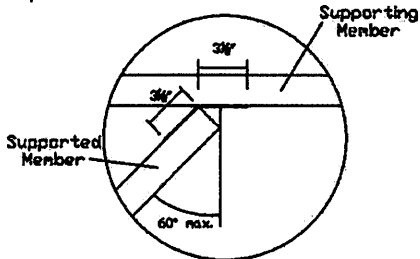
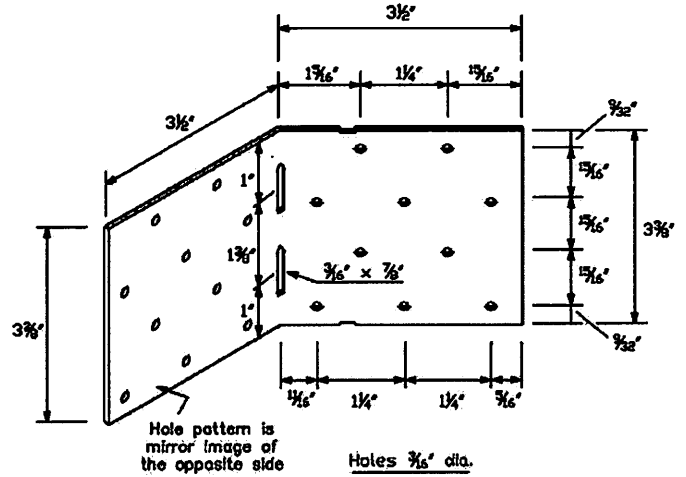

TABLE 17 SKEWED NAIL PLATE				
Product Code	Steel Gauge	Fastener Schedule	Allowable Loads (lbs)	
			Each End	Gravity
NVSNP3	16	(6) 8d x 1½"	570	570

For Uplift, use two NVSNP3, one at top chord and one at bottom chord of the supporting and supported Trusses in compliance with section 2321.7 of the FBC.
 $C_D=1.0$ —Gravity
 $C_D=1.6$ —Uplift



NVSNP3 Installation



14G Straps NVTH358/NVTH458		
Assembly Product Code	14G Strap Product Code	Dimension H (inches)
NV358-12 NV458-12	NVTH16	12
NV358-14 NV458-14	NVTH18	14
NV358-16 NV458-16	NVTH20	16
NV358-20 NV458-20	NVTH24	20
NV358-22 NV458-22	NVTH26	22
NV358-24 NV458-24	NVTH28	24
NV358-26 NV458-26	NVTH30	26
NV358-32 NV458-32	NVTH36	32
NV358-44 NV458-44	NVTH48	44

TABLE 18 — NVTH358—2 Ply Seat					
Total No. of Fasteners in 2 Straps 10d x 3"	Total No. of Fasteners in Seat 10d x 3"	Allowable Loads (lbs)			
		Uplift	L1	L2	
8	8	2245	1961	1839	
10	8	2525	2206	2068	
12	8	2806	2452	2298	
14	8	3086	2697	2528	
16	8	3367	2942	2758	

TABLE 19 — NVTH458—2 Ply Seat					
Total No. of Fasteners in 2 Straps 10d x 3"	Total No. of Fasteners in Seat 10d x 3"	Allowable Loads (lbs)			
		Uplift	L1	L2	
8	8	2245	2783	2078	
10	8	2525	3131	2338	
12	8	2806	3479	2597	
14	8	3086	3827	2857	
16	8	3367	4175	3117	

$C_D=1.6$ for Uplift L1 & L2.

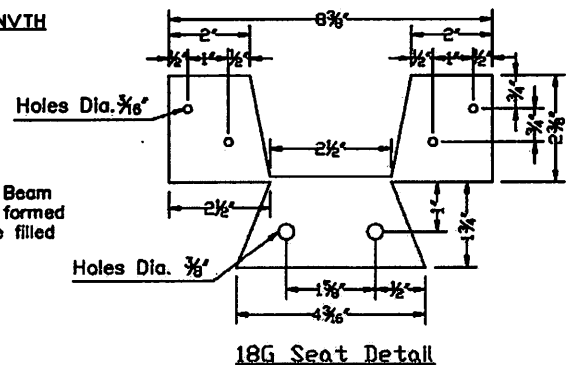
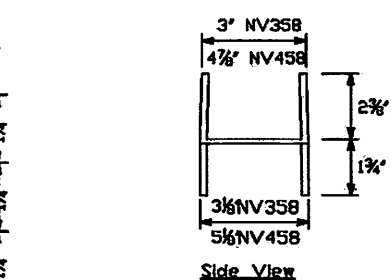
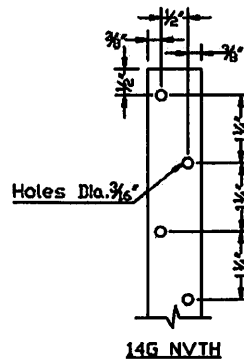
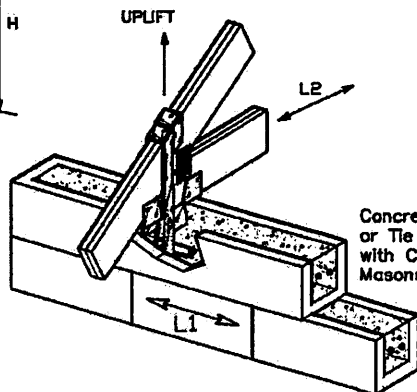
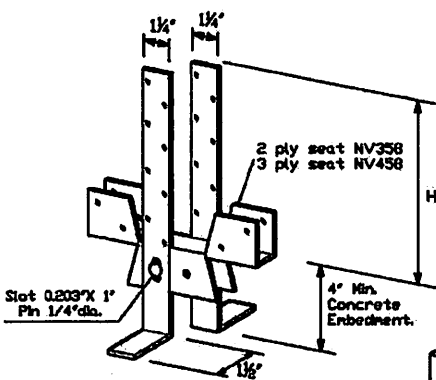
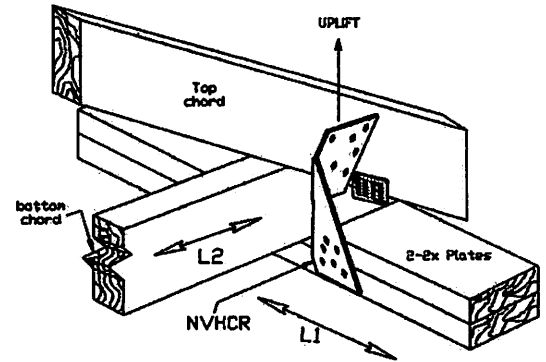
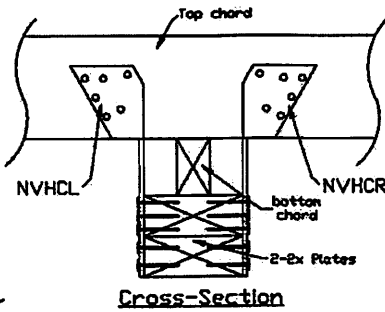
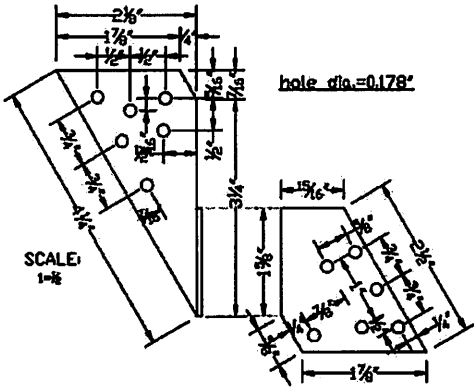

TABLE 20
HURRICANE CLIPS

Product Code	Description	Gauge	Fasteners 10d x 1/2"		Allowable Loads (lbs)		
			Header	Joist	Uplift	L1	L2
NVHCR	HURRICANE CLIP - RIGHT	18	6	6	525	253	333
NVHCL	HURRICANE CLIP - LEFT	18	6	6	525	253	333

For Uplift, use two clips, one on each side to comply with section 2321.7 of the FBC.
C_D=1.6 for Uplift, L1 & L2.



Assembly Product Code	14G Strap Product Code	Dimension H (inches)
NVSTA-12H	NVTH16	12
NVHTA-12H	NVTH16	12
NVSTA-14H	NVTH18	14
NVHTA-14H	NVTH18	14
NVSTA-16H	NVTH20	16
NVHTA-16H	NVTH20	16
NVSTA-20H	NVTH24	20
NVHTA-20H	NVTH24	20
NVSTA-22H	NVTH26	22
NVHTA-22H	NVTH26	22
NVSTA-24H	NVTH28	24
NVHTA-24H	NVTH28	24
NVSTA-26H	NVTH30	26
NVHTA-26H	NVTH30	26
NVSTA-32H	NVTH36	32
NVHTA-32H	NVTH36	32
NVSTA-44H	NVTH48	44
NVHTA-44H	NVTH48	44

Total No. of Fasteners in Straps 10d x 1/2"	Total No. of Fasteners in 20 GA. Seat 10d x 1/2"	Allowable Loads (lbs) F _c =2500 Psi		
		Uplift	L1	L2
5	6	1308	700	1049
6	6	1426	760	1144
7	6	1545	823	1239
8	6	1664	887	1335
9	6	1783	950	1430

C_D=1.6 for Uplift L1 & L2.

Total No. of Fasteners in 2 Straps 10d x 3"	Total No. of Fasteners in Seat 10d x 3"	Allowable Loads (lbs) F _c =2500 Psi Unless Noted			
		Uplift	Uplift F _c =3000	L1	L2
8	8	1772	2078	1050	1450
10	8	1994	2338	1181	1631
12	8	2215	2598	1312	1812
14	8	2437	2858	1444	1994
16	8	2658	3117	1575	2175

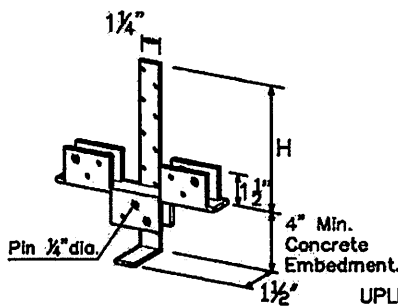
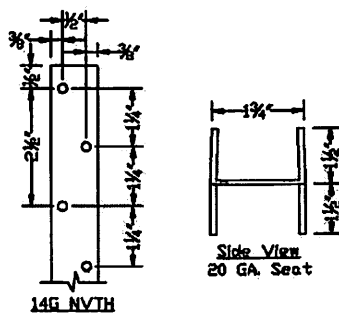

NVSTA 12H
44H

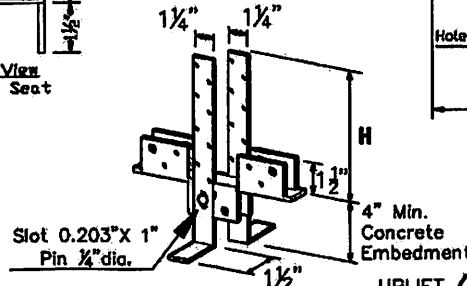
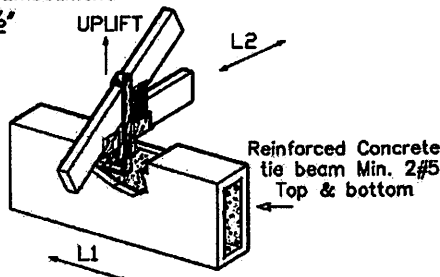

NVHTA 12H
44H

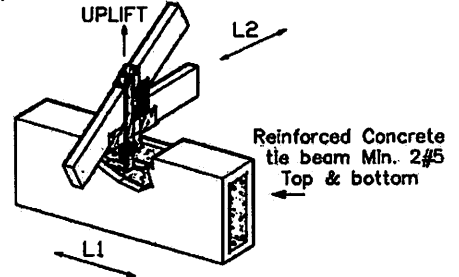
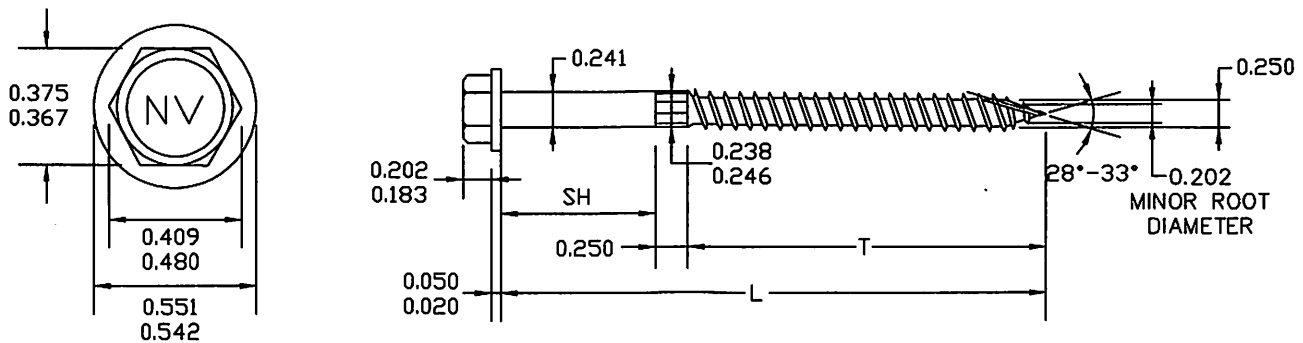

TABLE 23A

NVWS-WOOD SCREW SPECIFICATIONS, BENDING YIELD STRENGTH,
AND ALLOWABLE SCREW STRENGTH

Fastener Designation	Screw Dimensions (inches)			Bending Yield 1 Strength F_{yb} (psi)	Screw Ultimate Strength (lbs)		Allowable ² Screw design Strength (lbs)	
	Overall L Length	SH(in)	Thread T Length		Tension	Shear	Tension	Shear
NVWS1.5	1½"	¼"	1¼"	174,906	4452	2754	1484	918
NVWS3	3"	¾"	2¼"	156,893	4563	2715	1521	905

1. Do not use Bending yield Strength to calculate Lateral design values per NDS. Use Lateral design values as shown in table 3.
2. Allowable design loads are ultimate loads divided by a factor of safety of 3.



NVWS SCREW

Structural Notes:

1. NVWS wood screws are manufactured from SAEC-1022 steel with a zinc yellow chromate finish.
2. Allowable loads are based on 1½" thick wood members.
3. All tests have been conducted in accordance with ASTM D1761, ASTM F1575, ASTM D1037 and AISI S904.
4. Allowable Lateral Loads are based on tests conducted and not based on NDS.
5. Design loads are for Douglas Fir and Southern Pine with a specific gravity of 0.50 and moisture content between 11% and 19%.
6. Loads shown in tables 23B, C, D can be increased by adjustment factor $C_D=1.6$ for uplift and lateral loads and other adjustment factors in accordance with NSD 2018/2015.
7. All designs conform to FBC 2020/2017, ASTM D7147-2005/2011 .

TABLE 23B

Withdrawal Design Values for NVWS Screws
Wood Specific Gravity 0.5, Moisture Content > 11.0

	Screws Length (inches)	Thread Length (inches)	Withdrawal Design value lbs	Withdrawal Design value lbs/inch of Thread length
NVWS1.5	1½	1¼	175	141
NVWS3	3	2	296	148

TABLE 23C

Lateral Design Values for single shear NVWS Screws
Wood Specific Gravity 0.5, Moisture Content > 11.0

Fastener Designation	14 G Steel to Wood lbs	Wood to Wood lbs
NVWS1.5	201	-
NVWS3	308	236

TABLE 23D

Pull Through Design Values for NVWS Screws Wood Specific Gravity 0.5, Moisture Content > 11.0

Fastener Designation	Pull Through Design Value lbs
NVWS1.5	313
NVWS3	351

TABLE 23E

<p>Spacing and Edge distance Minimum Spacing between fasteners = 2" Minimum Edge distance = ¾"</p>
--

TABLE 24

NVHGA10 HURRICANE GUSSET ANGLE ALLOWABLE LOADS^{1,2}

Product Designation	Steel Gage	Dimensions (in)			Fastener Schedule				Allowable Loads (lbs)			
		W	H	L	Plate		Rafter/Truss		F ₁	F ₂ ¹	F ₃	Uplift
					Qty.	Type	Qty.	Type	C _{D=1.6}	C _{D=1.6}	C _{D=1.6}	C _{D=1.6}
NVHGA10	14	3½"	3	2	4	NVWS3	4	NVWS1.5	1286	1091	1120	790

1. Allowable loads in the F₂ direction are based on compression perpendicular to grain design value, F_{C⊥} of 565 psi or greater.

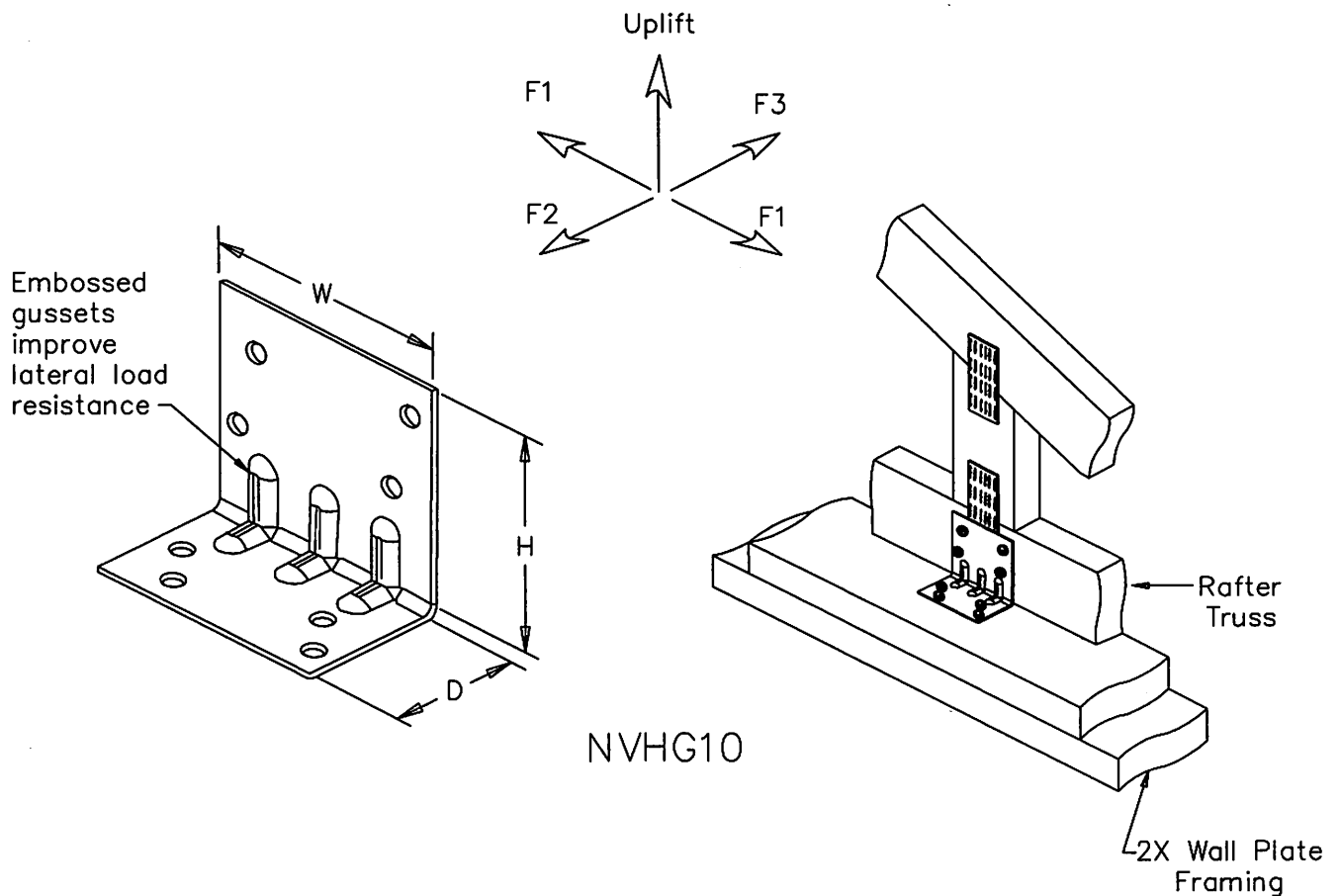

General Notes:

1. Steel shall conform to ASTM A653, SS grade 40 minimum yield 40 ksi, minimum tensile strength 55 ksi and minimum galvanized coating of G 60 per ASTM A653.
2. Allowable loads and fasteners are based on Tables 23.
3. Design loads are for S, Pine/D. Fir specific gravity 0.50.
4. Combined load of Uplift and Lateral Loads shall be satisfy the following equation.

$$\frac{\text{Actual Uplift}}{\text{Allowable Uplift}} + \frac{\text{Actual F}_1, \text{F}_2, \text{F}_3}{\text{Allowable F}_1, \text{F}_2, \text{F}_3} \leq 1.0$$

5. Allowable loads are based on 1½" thick wood members unless otherwise noted.
6. All design Conform to FBC 2020/2017, ASTM D1761, ASTM D7147, and NDS 2018/2015.