

REVISIONS			
REV	DESCRIPTION	DATE	APPROVED
H	ADDED TRIMS & 5180 HOT MELT BUTYL	08/24/2021	R.L.

NOTES:

- THE PRODUCT SHOWN HEREIN IS DESIGNED AND MANUFACTURED TO COMPLY WITH REQUIREMENTS OF THE FLORIDA BUILDING CODE.
- WOOD FRAMING, METAL STRUCTURE AND MASONRY OPENING TO BE DESIGNED AND ANCHORED TO PROPERLY TRANSFER ALL LOADS TO STRUCTURE. FRAMING AND MASONRY OPENING IS THE RESPONSIBILITY OF THE ARCHITECT OR ENGINEER OF RECORD.
- 1X BUCK OVER MASONRY/CONCRETE IS OPTIONAL. WHERE 1X BUCK IS NOT USED DISSIMILAR MATERIALS MUST BE SEPARATED WITH APPROVED COATING OR MEMBRANE. SELECTION OF COATING OR MEMBRANE IS THE RESPONSIBILITY OF THE ARCHITECT OR ENGINEER OF RECORD.
- ALLOWABLE STRESS INCREASE OF 1/3 WAS NOT USED IN THE DESIGN OF THE PRODUCT SHOWN HEREIN. WIND LOAD DURATION FACTOR Cd=1.6 WAS USED FOR WOOD ANCHOR CALCULATIONS.
- FRAME MATERIAL: WOOD WITH G=.46 MINIMUM SPECIFIC GRAVITY, OR COMPOSITE, OR FRAMESAVER, OR FUSION FRAME.  
DOOR SKIN MATERIAL: STEEL .033" THICK (MINIMUM), FIBERGLASS .085" THICK (MINIMUM).  
SIDELITE SKIN MATERIAL: STEEL .022" THICK (MINIMUM)
- SIDELITES MUST BE GLAZED PER ASTM E1300, SEE SHEET 11 FOR GLASS DETAILS.
- APPROVED IMPACT PROTECTIVE SYSTEM IS NOT REQUIRED FOR THIS PRODUCT IN WIND BORNE DEBRIS REGIONS UP TO WIND ZONE 3.
- SHIM AS REQUIRED AT EACH INSTALLATION ANCHOR WITH LOAD BEARING SHIM. SHIM WHERE SPACE OF 1/16" OR GREATER OCCURS. MAXIMUM ALLOWABLE SHIM STACK TO BE 1/4".
- FOR ANCHORING INTO WOOD FRAMING OR 2X BUCK USE #10 WOOD SCREWS WITH SUFFICIENT LENGTH TO ACHIEVE A 1 3/8" MINIMUM EMBEDMENT INTO SUBSTRATE. LOCATE ANCHORS AS SHOWN IN ELEVATIONS AND INSTALLATION DETAILS.
- FOR ANCHORING INTO MASONRY/CONCRETE USE 3/16" TAPCONS WITH SUFFICIENT LENGTH TO ACHIEVE A 1 3/4" MINIMUM EMBEDMENT INTO SUBSTRATE WITH 2" MINIMUM EDGE DISTANCE. LOCATE ANCHORS AS SHOWN IN ELEVATIONS AND INSTALLATION DETAILS.
- FOR ANCHORING INTO METAL STRUCTURE USE #10 SMS OR SELF DRILLING SCREWS WITH SUFFICIENT LENGTH TO ACHIEVE 3 THREADS MINIMUM BEYOND STRUCTURE INTERIOR WALL. LOCATE ANCHORS AS SHOWN IN ELEVATIONS AND INSTALLATION DETAILS.
- ALL FASTENERS TO BE CORROSION RESISTANT.
- INSTALLATION ANCHORS SHALL BE INSTALLED IN ACCORDANCE WITH ANCHOR MANUFACTURER'S INSTALLATION INSTRUCTIONS AND ANCHORS SHALL NOT BE USED IN SUBSTRATES WITH STRENGTHS LESS THAN THE MINIMUM STRENGTH SPECIFIED BELOW:
  - WOOD – MINIMUM SPECIFIC GRAVITY OF G=0.42
  - CONCRETE – MINIMUM COMPRESSIVE STRENGTH OF 3,192 PSI.
  - MASONRY – GROUT FILLED STRENGTH CONFORMANCE TO ASTM C-90, GRADE N, TYPE 1 (OR GREATER).
  - METAL STRUCTURE: STEEL 18GA, 33KSI OR ALUMINUM 6063-T5 .048" THICK MINIMUM
- DOOR CONSTRUCTION MAYBE CONTINUOUS HEAD FRAME AND CONTINUOUS THRESHOLD OR BOX CONSTRUCTION.

TABLE OF CONTENTS	
SHEET NO.	DESCRIPTION
1	NOTES
2 – 3	ELEVATIONS
4	ANCHORING LAYOUTS
5 – 10	INSTALLATION DETAILS
11	GLAZING DETAILS
12 – 16	APPROVED SLABS, MULLION DETAILS AND COMPONENTS

<b>PROVIA, LLC.</b> 2150 STATE ROUTE 39 WEST SUGARCREEK, OH 44681		
STEEL/FIBERGLASS INSWING OPAQUE DOUBLE DOOR W/SIDELITES – IMPACT NOTES		
DRAWN: V.L.	DWG NO. 08-02038	REV H
SCALE NTS	DATE 04/22/13	SHEET 1 OF 16
L. ROBERTO LOMAS P.E. 1432 WOODFORD RD LEWISVILLE, NC 27023 434-688-0609 rllomas@rlomaspe.com		

SIGNED: 09/08/2021

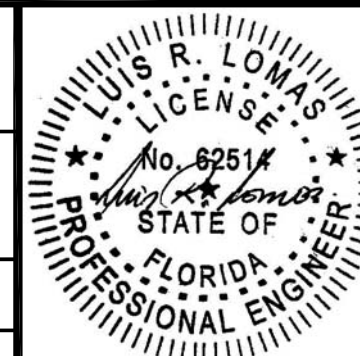

Luis R. Lomas P.E.  
FL No.: 62514

REVISIONS			
REV	DESCRIPTION	DATE	APPROVED
H	ADDED TRIMS & 5180 HOT MELT BUTYL	08/24/2021	R.L.

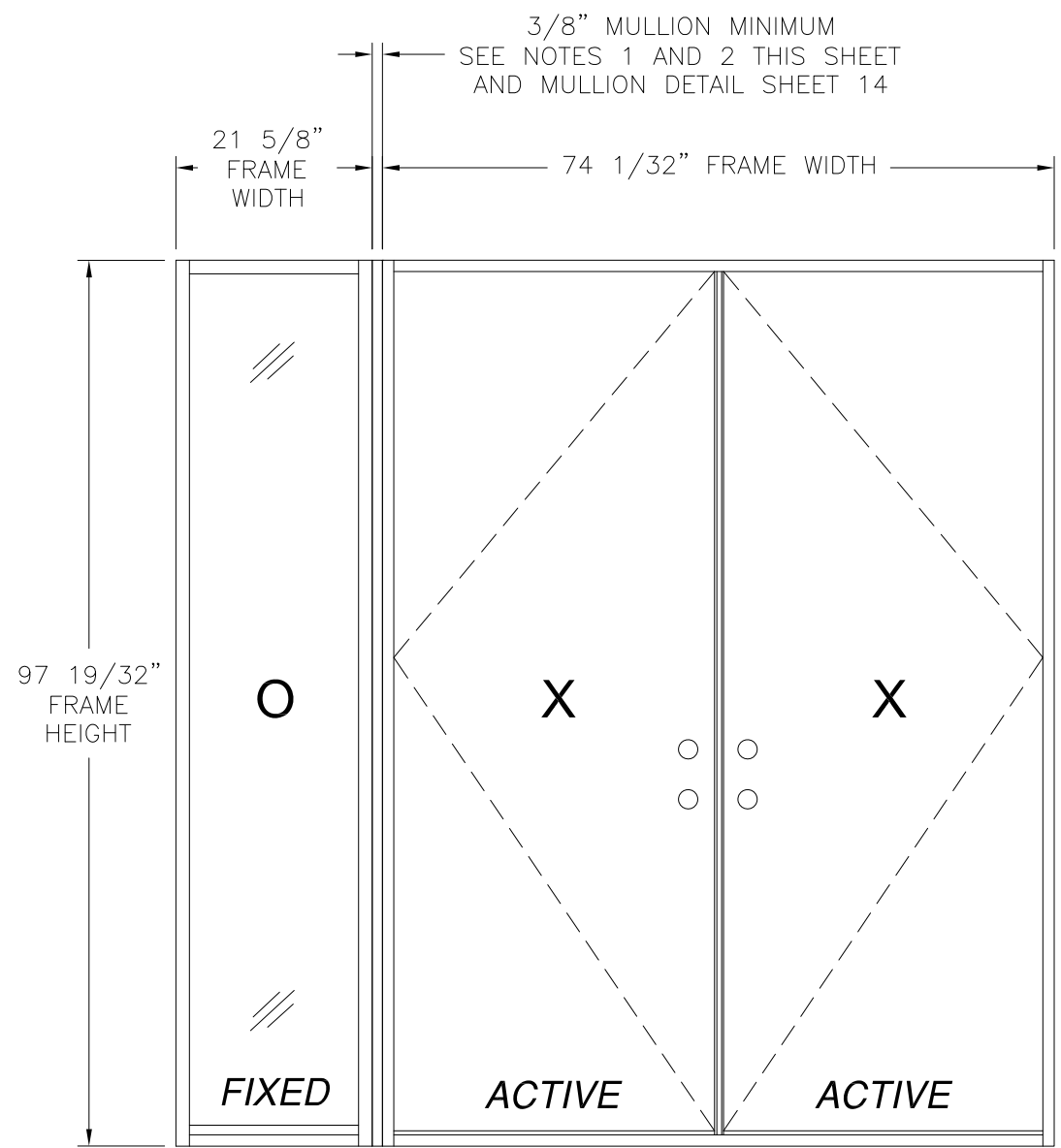

**DOUBLE DOOR W/ DIRECT SET SIDELITE**  
EXTERIOR VIEW  
OXX SHOWN XXO ALSO APPROVED

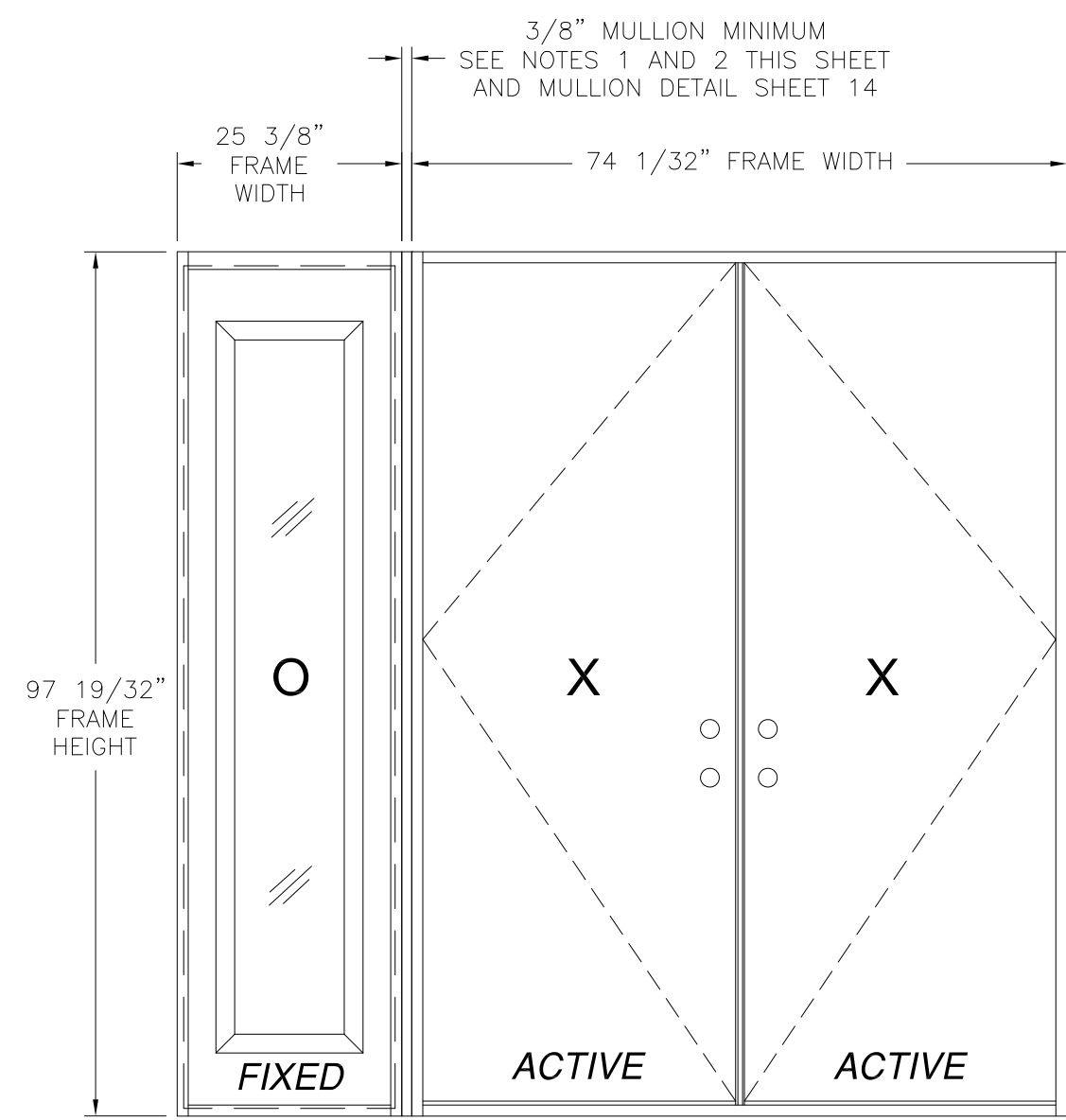

**DOUBLE DOOR WITH STANDARD SIDELITE**  
EXTERIOR VIEW  
OXX SHOWN XXO ALSO APPROVED

DESIGN PRESSURE RATING	IMPACT RATING
±55.0PSF	LARGE MISSILE IMPACT

MISSILE LEVEL D, WIND ZONE 3  
35 3/4" x 94 15/16" PANEL SIZE SHOWN. OTHER SIZES ARE APPROVED AS LONG AS INDIVIDUAL PANEL AREA DOES NOT EXCEED 23.56 FT<sup>2</sup>

- NOTES:
1. MAXIMUM ALLOWED BUILD UP TO BE 7" AT EACH VERTICAL MULLION.
  2. IF SIDELITE WIDTH IS 16" OR LESS NO VERTICAL MULLION IS REQUIRED.

PROVIA, LLC.  
2150 STATE ROUTE 39 WEST  
SUGARCREEK, OH 44681

STEEL/FIBERGLASS INSWING OPAQUE DOUBLE DOOR W/SIDELITES - IMPACT ELEVATIONS

DRAWN: V.L.	DWG NO. 08-02038	REV H
SCALE NTS	DATE 04/22/13	SHEET 2 OF 16

L. ROBERTO LOMAS P.E.  
1432 WOODFORD RD LEWISVILLE, NC 27023  
434-688-0609 rllomas@rlomaspe.com

SIGNED: 09/08/2021

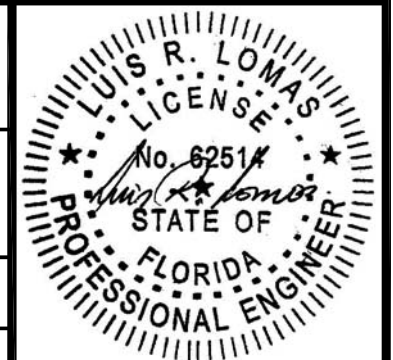

Luis R. Lomas P.E.  
FL No.: 62514

REVISIONS			
REV	DESCRIPTION	DATE	APPROVED
H	ADDED TRIMS & 5180 HOT MELT BUTYL	08/24/2021	R.L.

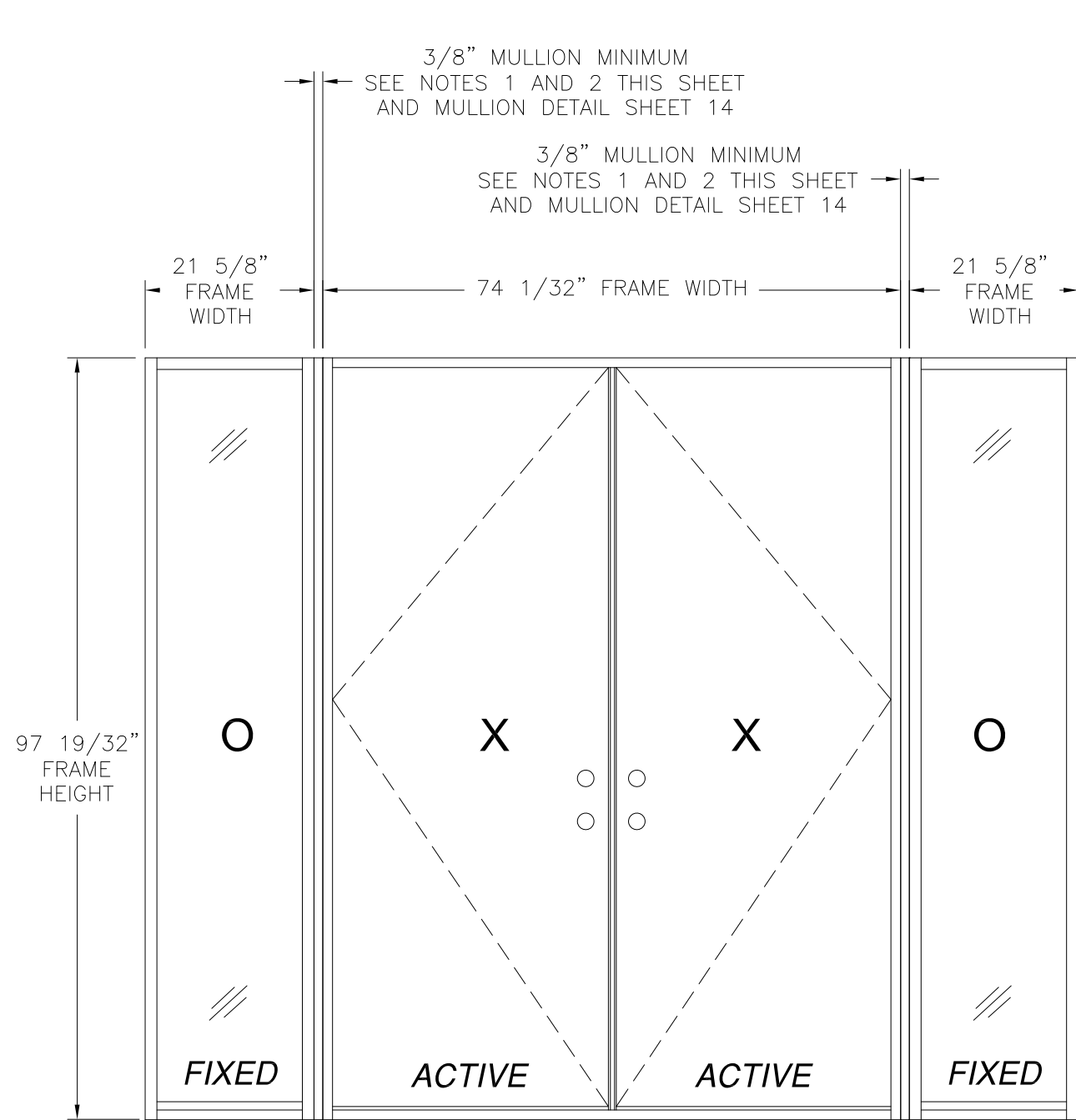

**DOUBLE DOOR WITH DIRECT SET SIDELITES**  
EXTERIOR VIEW

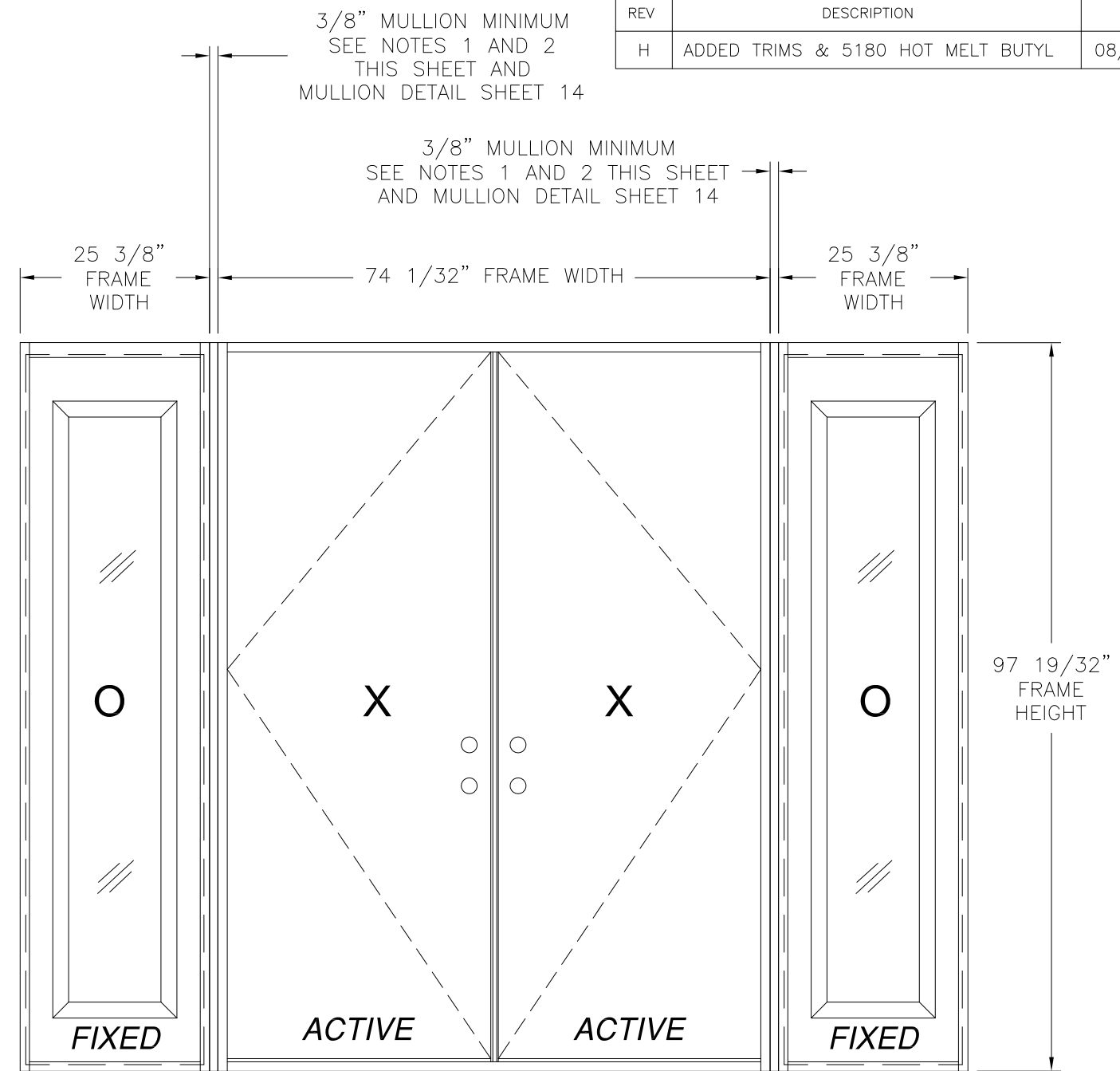

**DOUBLE DOOR WITH STANDARD SIDELITES**  
EXTERIOR VIEW

DESIGN PRESSURE RATING	IMPACT RATING
±55.0PSF	LARGE MISSILE IMPACT

MISSILE LEVEL D, WIND ZONE 3

35 3/4" x 94 15/16" PANEL SIZE SHOWN. OTHER SIZES ARE APPROVED AS LONG AS INDIVIDUAL PANEL AREA DOES NOT EXCEED 23.56 FT<sup>2</sup>

- NOTES:
1. MAXIMUM ALLOWED BUILD UP TO BE 7" AT EACH VERTICAL MULLION.
  2. IF SIDELITE WIDTH IS 16" OR LESS NO VERTICAL MULLION IS REQUIRED.

PROVIA, LLC.  
2150 STATE ROUTE 39 WEST  
SUGARCREEK, OH 44681

STEEL/FIBERGLASS INSWING OPAQUE DOUBLE DOOR  
W/SIDELITES - IMPACT  
ELEVATIONS

DRAWN: V.L.	DWG NO. 08-02038	REV H
SCALE NTS	DATE 04/22/13	SHEET 3 OF 16

L. ROBERTO LOMAS P.E.  
1432 WOODFORD RD LEWISVILLE, NC 27023  
434-688-0609 rllomas@rlomaspe.com

SIGNED: 09/08/2021

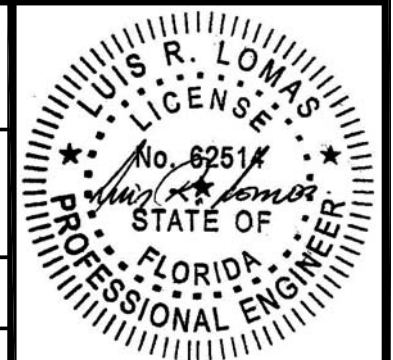

Luis R. Lomas P.E.  
FL No.: 62514

REVISIONS			
REV	DESCRIPTION	DATE	APPROVED
H	ADDED TRIMS & 5180 HOT MELT BUTYL	08/24/2021	R.L.

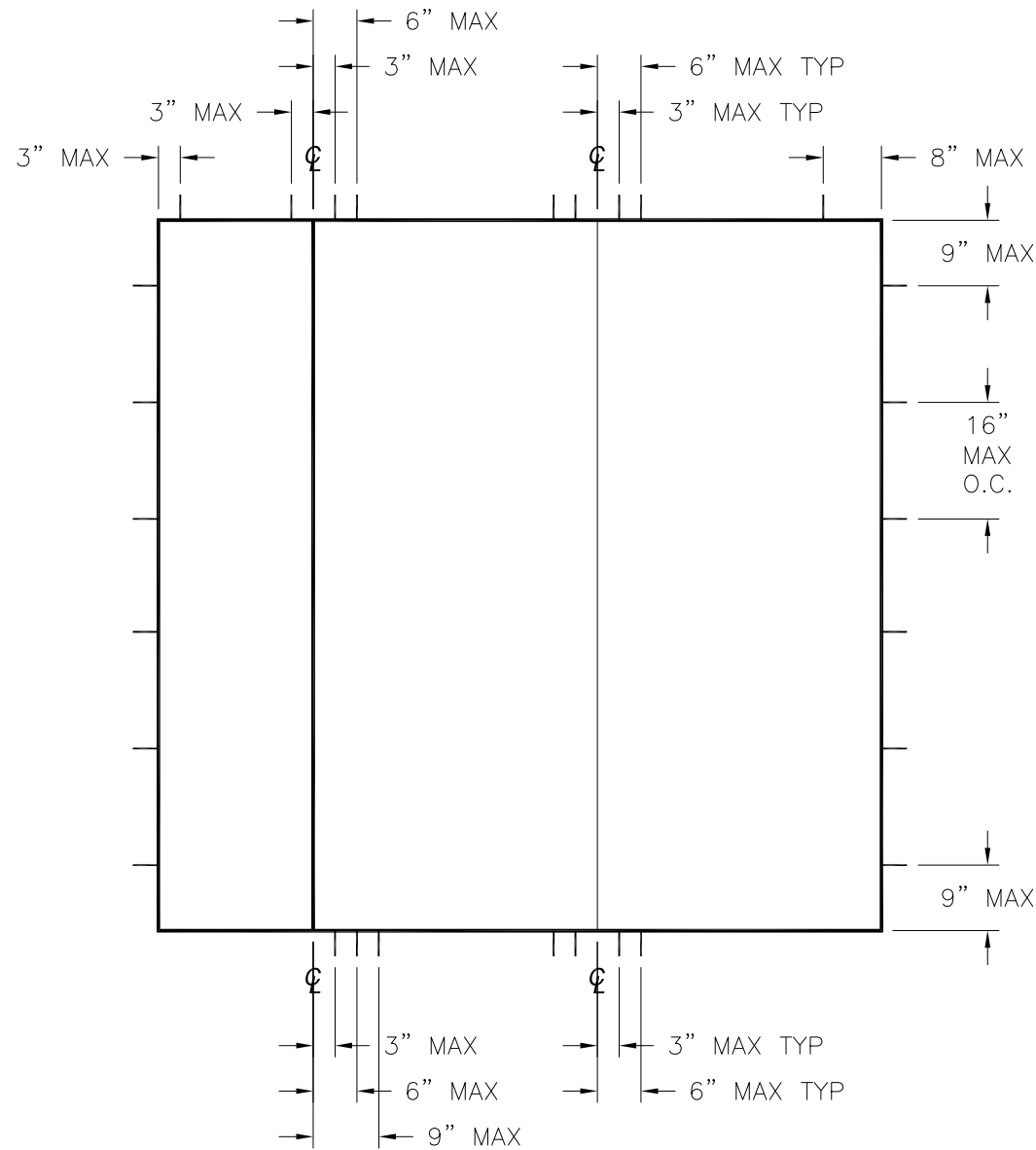

**DOUBLE DOOR WITH SIDELITE**

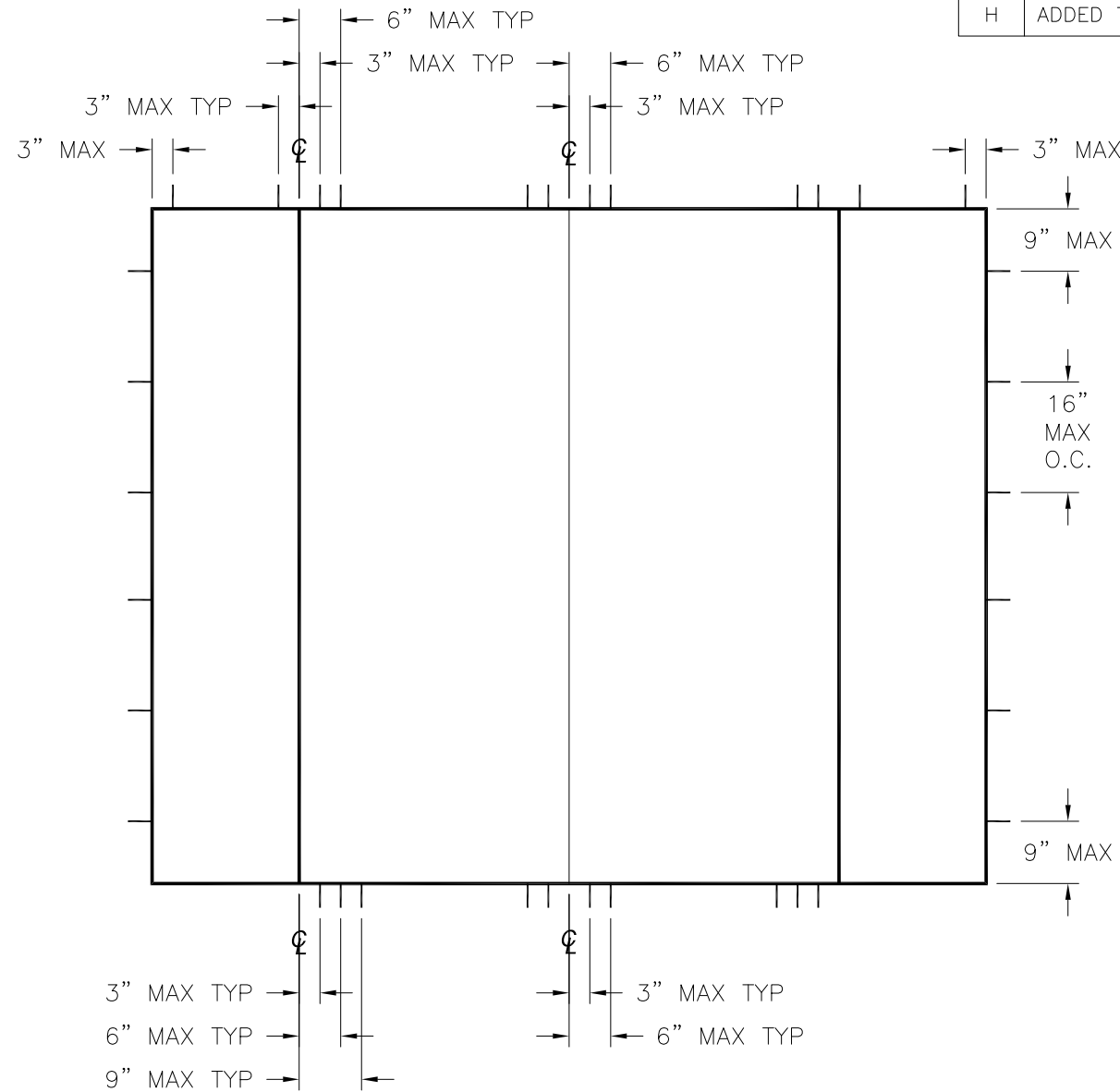

**DOUBLE DOOR WITH SIDELITES**

HARDWARE SCHEDULE	
A.	F-SERIES LOCK ASSEMBLY DOOR KNOB BY SCHLAGE.
B.	B-SERIES DEADBOLT ASSEMBLY BY SCHLAGE.
C.	F-SERIES DEADBOLT ASSEMBLY BY SCHLAGE.
D.	RESIDENTIAL GRADE DOOR HANDLE ASSEMBLY BY EMTEK (ALTERNATE).
E.	MULTI-POINT LOCK HANDLE ASSEMBLY BY TRILENNIUM (ALTERNATE).
F.	(3) 4" x 4" BALL BEARING HINGES BY PENROD.
G.	(3) 4" x 4" SPRING BOMMER HINGES BY PENROD. (ALTERNATE)

<b>PROVIA, LLC.</b> 2150 STATE ROUTE 39 WEST SUGARCREEK, OH 44681		
STEEL/FIBERGLASS INSWING OPAQUE DOUBLE DOOR W/SIDELITES – IMPACT ANCHORING LAYOUTS		
DRAWN: V.L.	DWG NO. 08-02038	REV H
SCALE NTS	DATE 04/22/13	SHEET 4 OF 16
L. ROBERTO LOMAS P.E. 1432 WOODFORD RD LEWISVILLE, NC 27023 434-688-0609 rllomas@lrlomaspe.com		

SIGNED: 09/08/2021

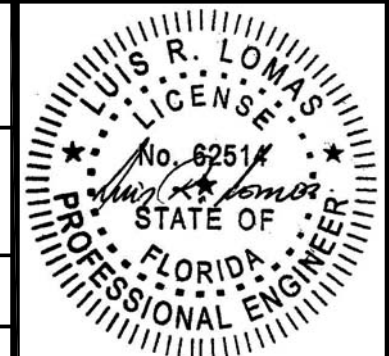

Luis R. Lomas P.E.  
FL No.: 62514

REVISIONS			
REV	DESCRIPTION	DATE	APPROVED
H	ADDED TRIMS & 5180 HOT MELT BUTYL	08/24/2021	R.L.

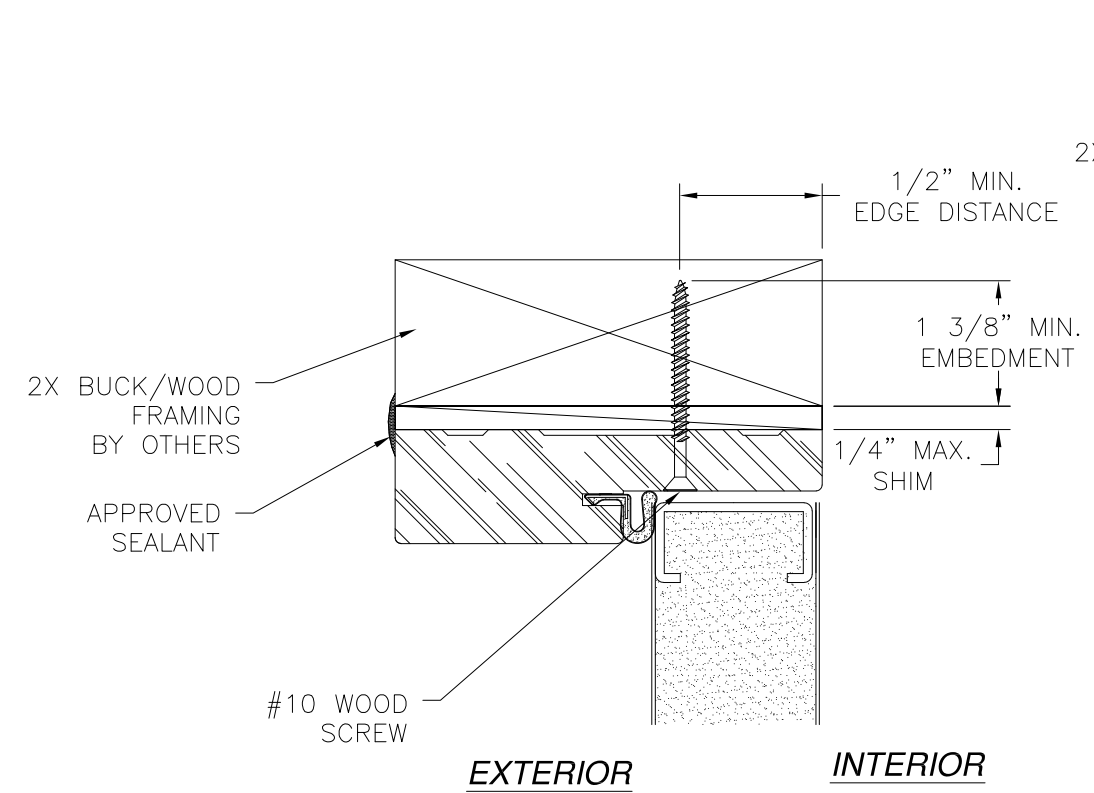

**VERTICAL CROSS SECTION**  
DOOR INSTALLATION - 2X BUCK/WOOD FRAMING

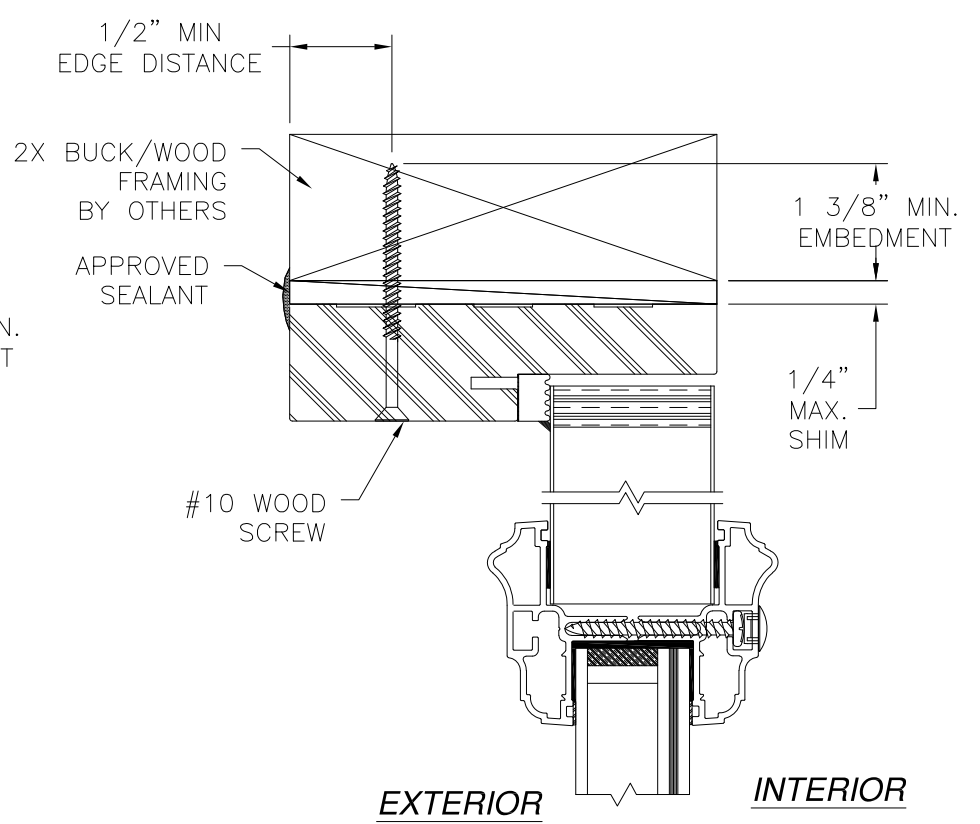

**VERTICAL CROSS SECTION**  
SIDELITE INSTALLATION 2X BUCK/WOOD FRAMING  
STANDARD SIDELITE SHOWN  
DIRECT SET SIDELITE SIMILAR

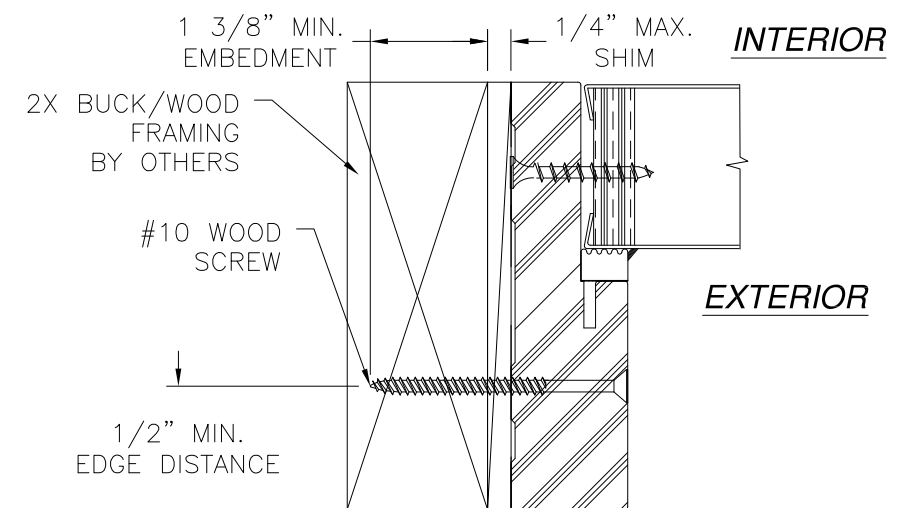

**HORIZONTAL CROSS SECTION**  
SIDELITE INSTALLATION 2X BUCK/WOOD FRAMING  
STANDARD SIDELITE SHOWN  
DIRECT SET SIDELITE SIMILAR

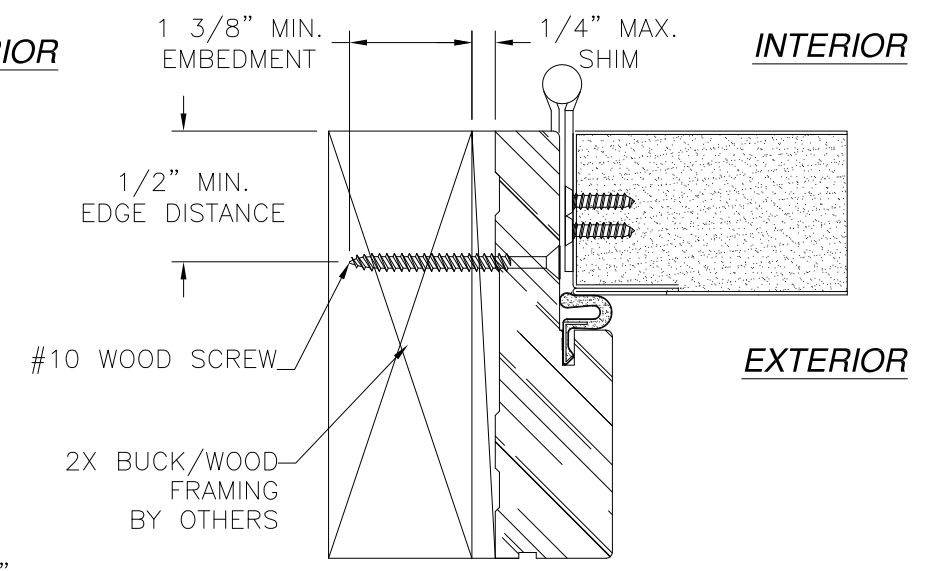

**HORIZONTAL CROSS SECTION**  
DOOR INSTALLATION - 2X BUCK/WOOD FRAMING

SIGNED: 09/08/2021

- NOTES:**
1. INTERIOR AND EXTERIOR FINISHES, BY OTHERS, NOT SHOWN FOR CLARITY.
  2. PERIMETER AND JOINT SEALANT BY OTHERS TO BE DESIGNED IN ACCORDANCE WITH ASTM E2112

**PROVIA, LLC.**  
2150 STATE ROUTE 39 WEST  
SUGARCREEK, OH 44681

---

STEEL/FIBERGLASS INSWING OPAQUE DOUBLE DOOR  
W/SIDELITES - IMPACT  
INSTALLATION DETAILS

DRAWN: V.L.	DWG NO. 08-02038	REV H
SCALE NTS	DATE 04/22/13	SHEET 5 OF 16

L. ROBERTO LOMAS P.E.  
1432 WOODFORD RD LEWISVILLE, NC 27023  
434-688-0609 rllomas@rlomaspe.com

Luis R. Lomas P.E.  
FL No.: 62514

REVISIONS			
REV	DESCRIPTION	DATE	APPROVED
H	ADDED TRIMS & 5180 HOT MELT BUTYL	08/24/2021	R.L.

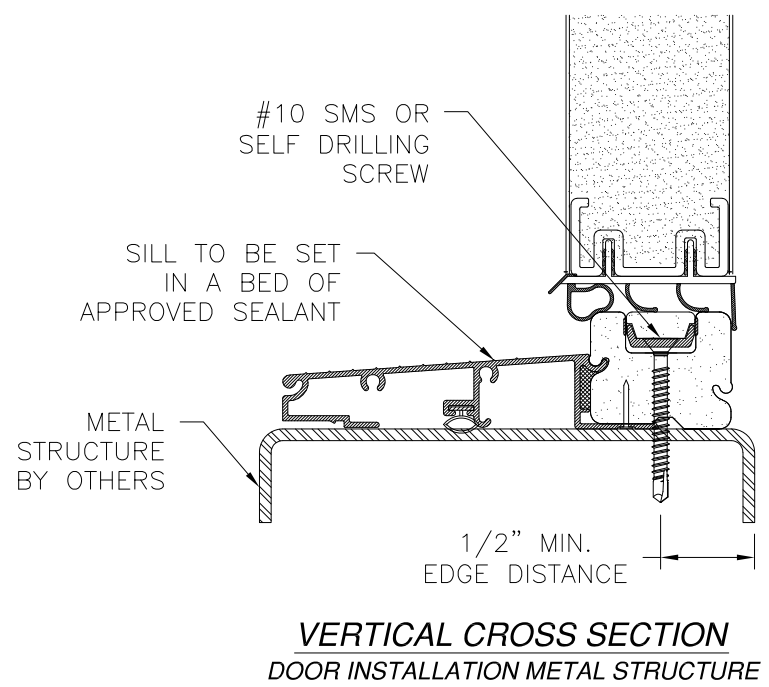
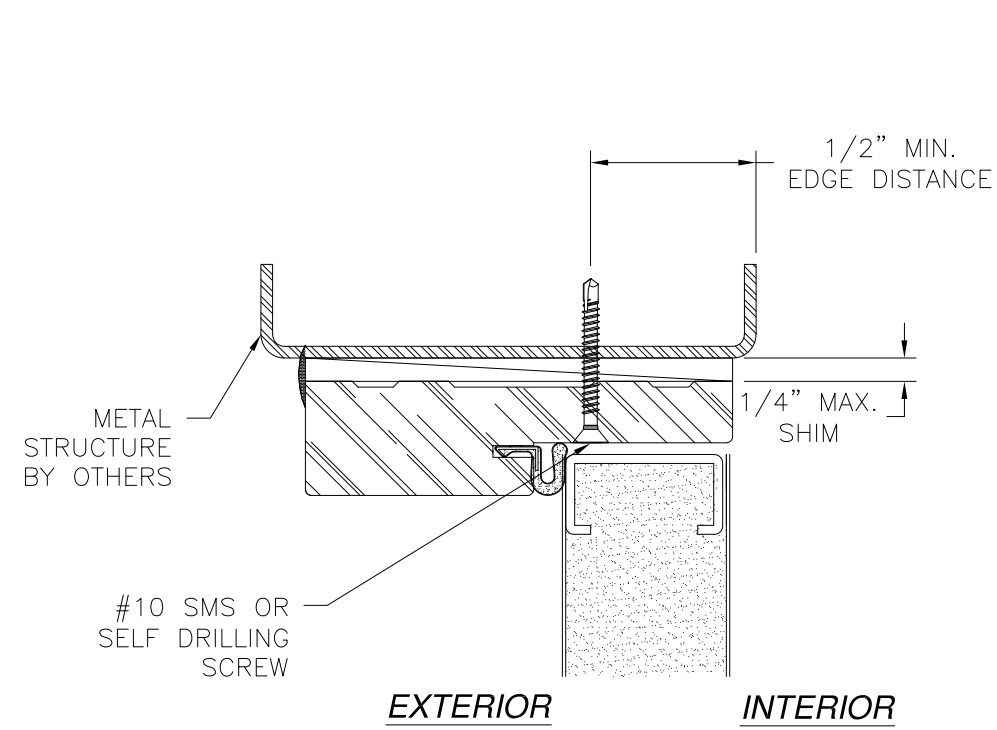

- NOTES:
1. INTERIOR AND EXTERIOR FINISHES, BY OTHERS, NOT SHOWN FOR CLARITY.
  2. PERIMETER AND JOINT SEALANT BY OTHERS TO BE DESIGNED IN ACCORDANCE WITH ASTM E2112

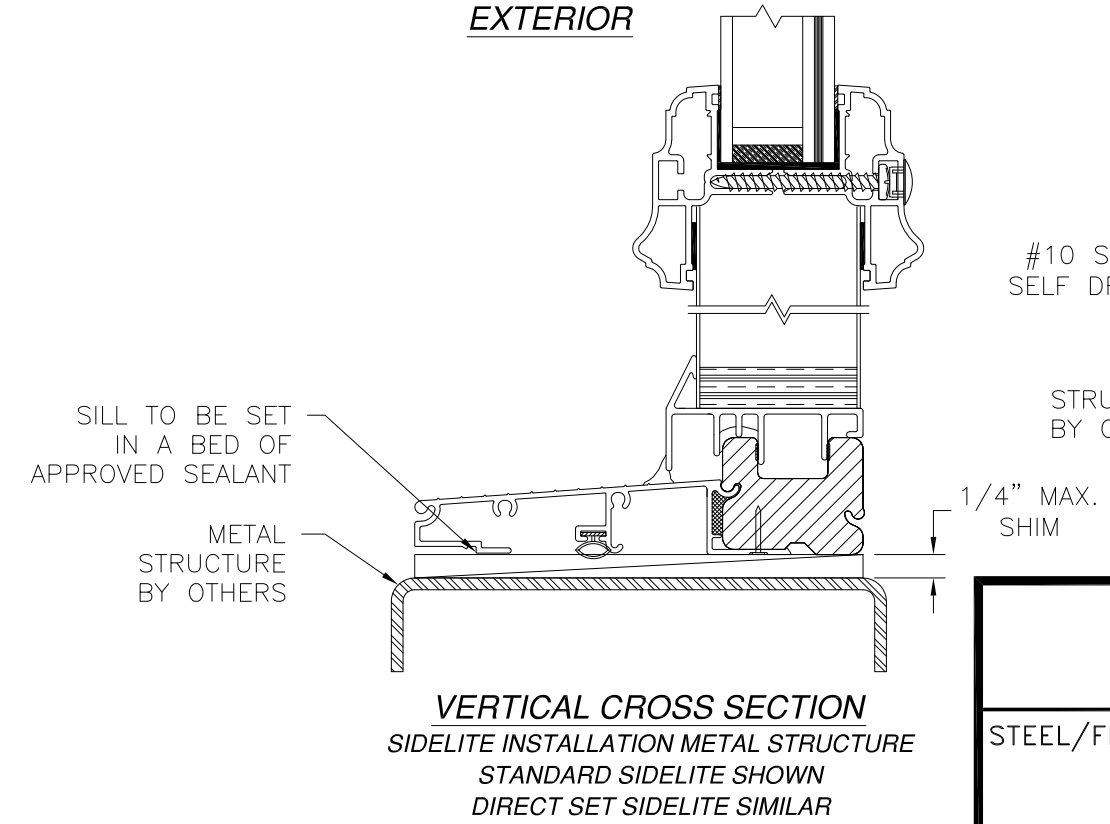
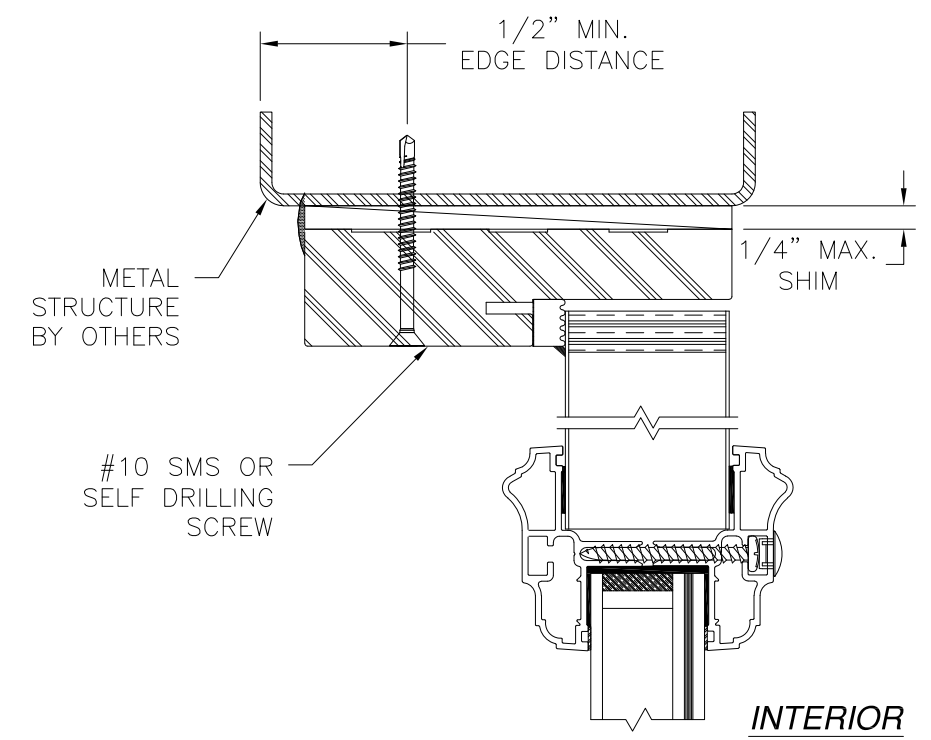

**VERTICAL CROSS SECTION**  
SIDELITE INSTALLATION METAL STRUCTURE  
STANDARD SIDELITE SHOWN  
DIRECT SET SIDELITE SIMILAR

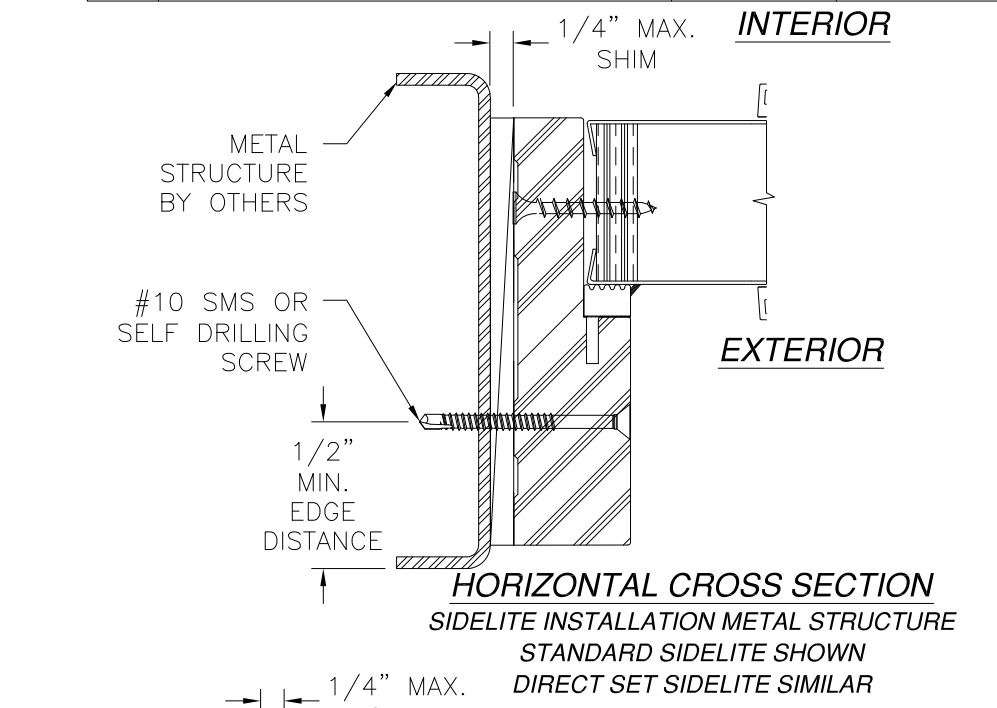

**HORIZONTAL CROSS SECTION**  
SIDELITE INSTALLATION METAL STRUCTURE  
STANDARD SIDELITE SHOWN  
DIRECT SET SIDELITE SIMILAR

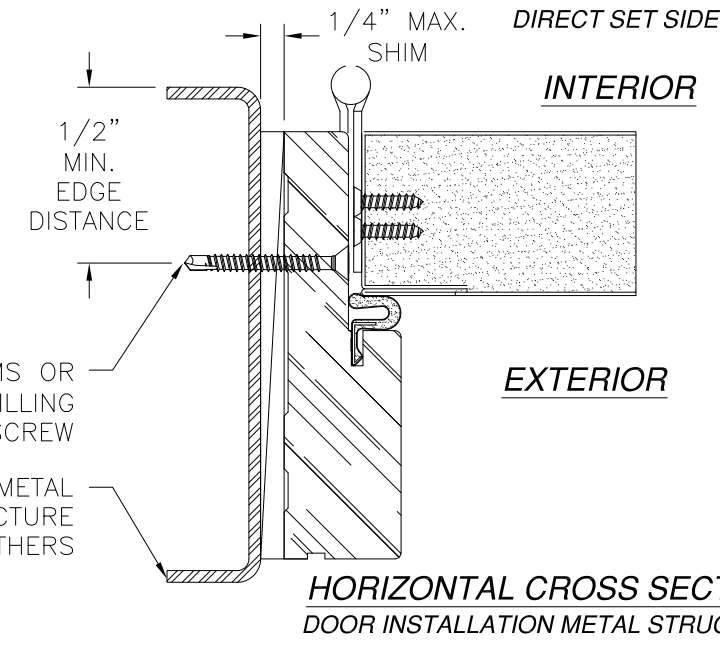

**HORIZONTAL CROSS SECTION**  
DOOR INSTALLATION METAL STRUCTURE

SIGNED: 09/08/2021

PROVIA, LLC.  
2150 STATE ROUTE 39 WEST  
SUGARCREEK, OH 44681

STEEL/FIBERGLASS INSWING OPAQUE DOUBLE DOOR  
W/SIDELITES - IMPACT  
INSTALLATION DETAILS

DRAWN: V.L.	DWG NO. 08-02038	REV H
SCALE NTS	DATE 04/22/13	SHEET 6 OF 16

L. ROBERTO LOMAS P.E.  
1432 WOODFORD RD LEWISVILLE, NC 27023  
434-688-0609 rllomas@rlomaspe.com

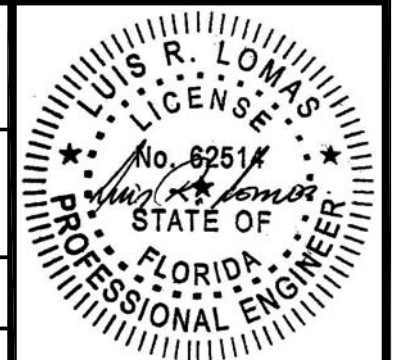

Luis R. Lomas P.E.  
FL No.: 62514

REVISIONS			
REV	DESCRIPTION	DATE	APPROVED
H	ADDED TRIMS & 5180 HOT MELT BUTYL	08/24/2021	R.L.

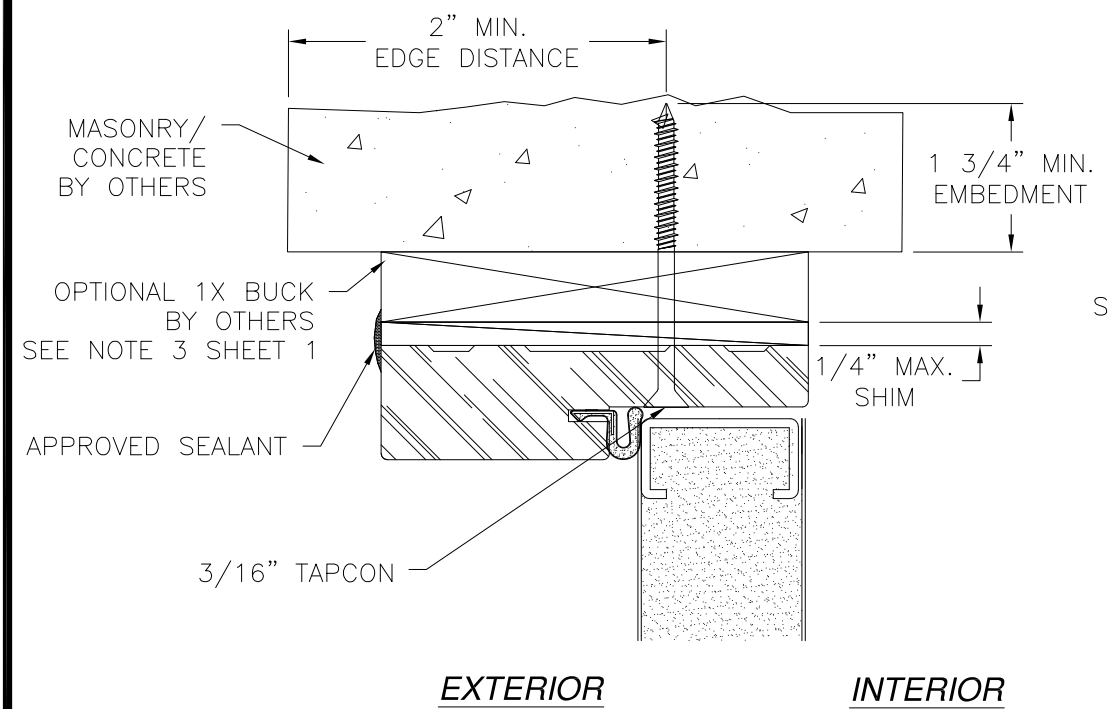

**EXTERIOR**      **INTERIOR**

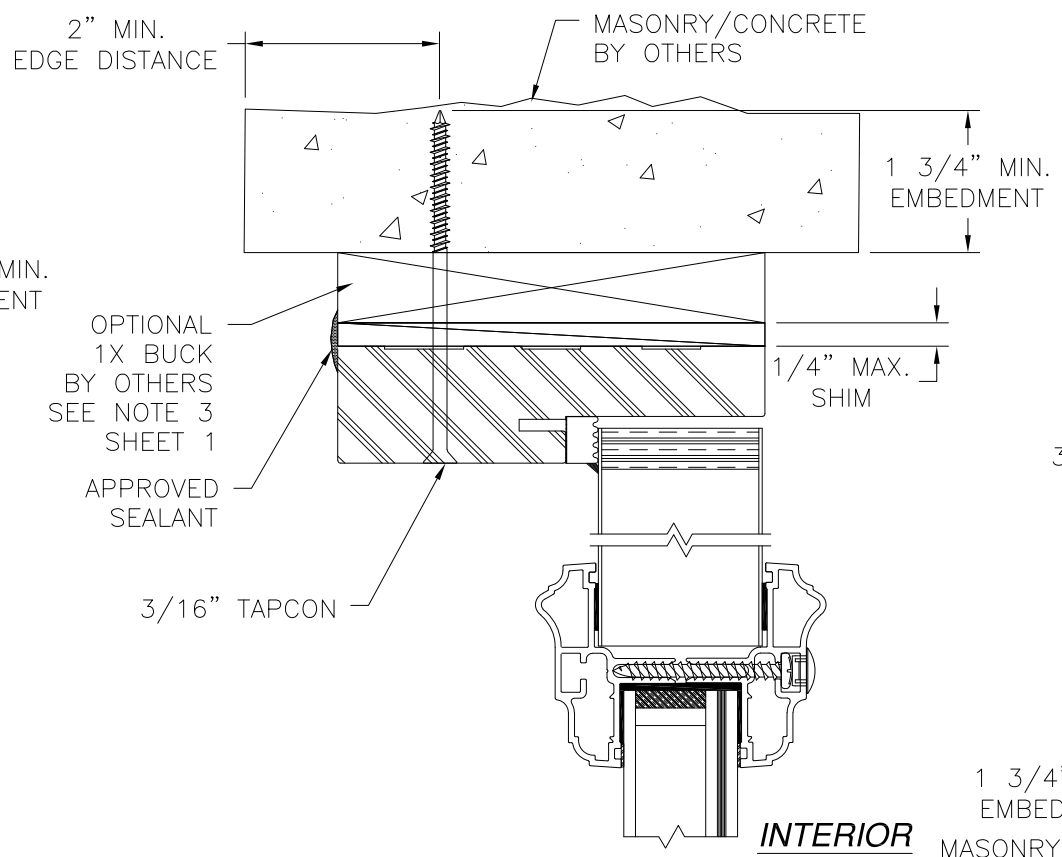

**EXTERIOR**      **INTERIOR**

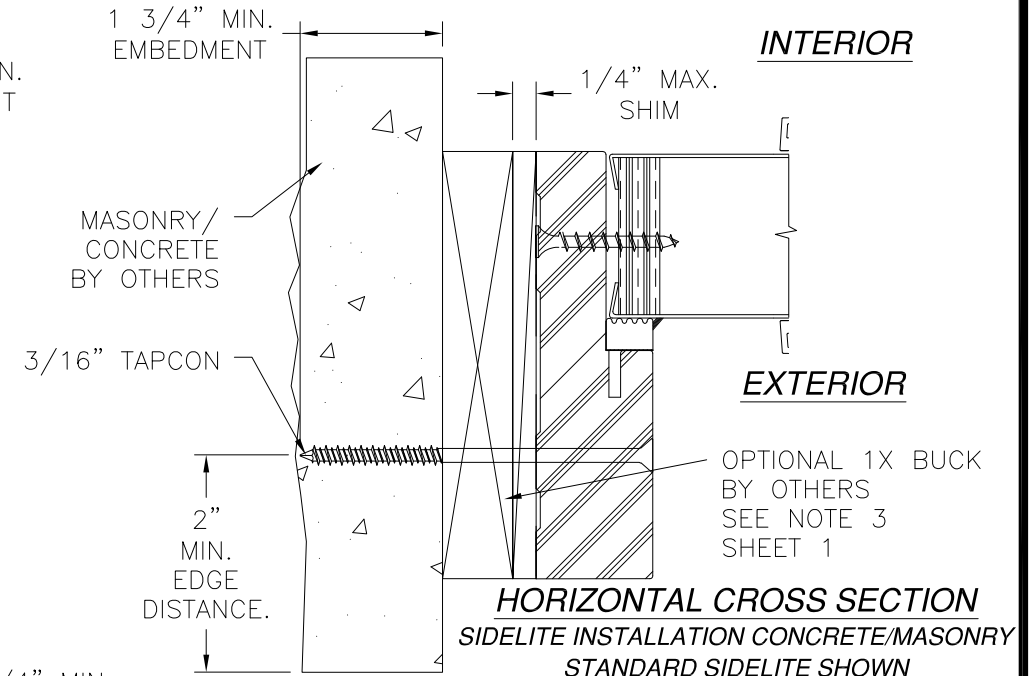

**HORIZONTAL CROSS SECTION**  
SIDELITE INSTALLATION CONCRETE/MASONRY  
STANDARD SIDELITE SHOWN  
DIRECT SET SIDELITE SIMILAR

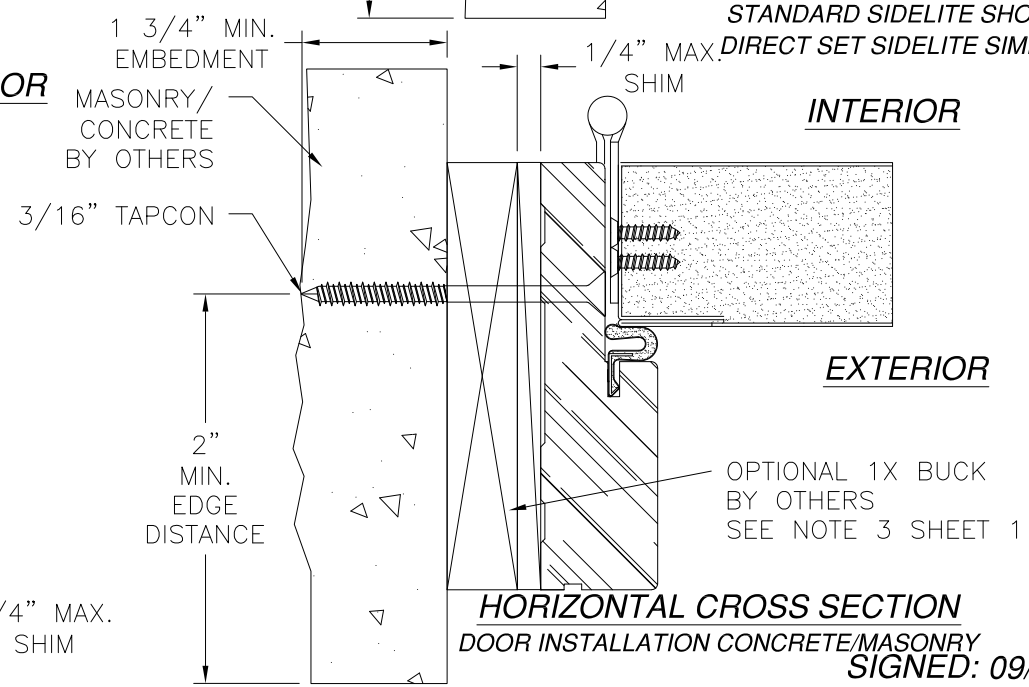

**HORIZONTAL CROSS SECTION**  
DOOR INSTALLATION CONCRETE/MASONRY  
SIGNED: 09/08/2021

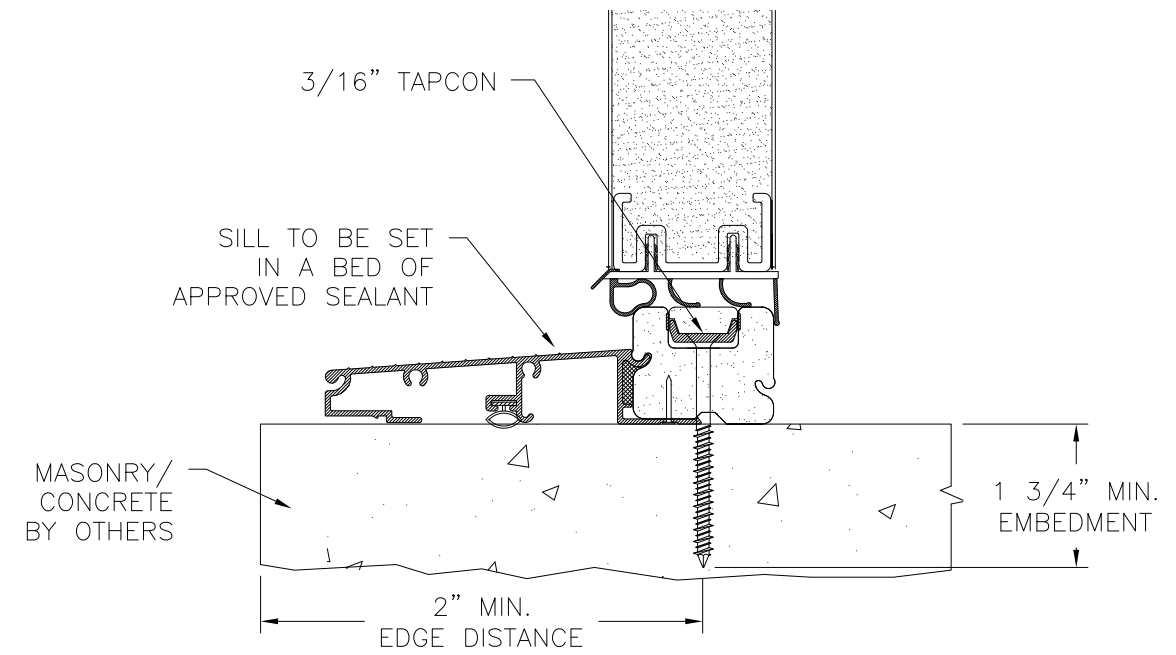

**VERTICAL CROSS SECTION**  
DOOR INSTALLATION MASONRY/CONCRETE

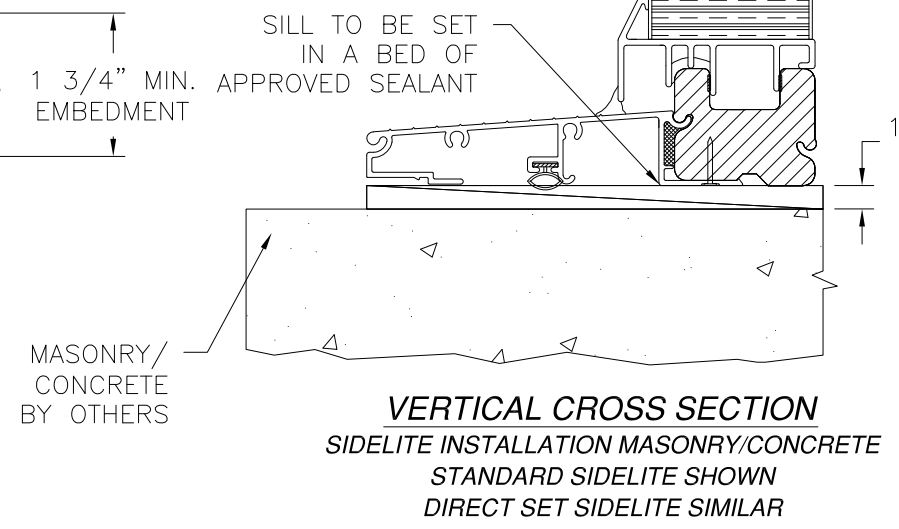

**VERTICAL CROSS SECTION**  
SIDELITE INSTALLATION MASONRY/CONCRETE  
STANDARD SIDELITE SHOWN  
DIRECT SET SIDELITE SIMILAR

- NOTES:**
1. INTERIOR AND EXTERIOR FINISHES, BY OTHERS, NOT SHOWN FOR CLARITY.
  2. PERIMETER AND JOINT SEALANT BY OTHERS TO BE DESIGNED IN ACCORDANCE WITH ASTM E2112

**PROVIA, LLC.**  
2150 STATE ROUTE 39 WEST  
SUGARCREEK, OH 44681

STEEL/FIBERGLASS INSWING OPAQUE DOUBLE DOOR  
W/SIDELITES - IMPACT  
INSTALLATION DETAILS

DRAWN: V.L.	DWG NO. 08-02038	REV H
SCALE NTS	DATE 04/22/13	SHEET 7 OF 16

L. ROBERTO LOMAS P.E.  
1432 WOODFORD RD LEWISVILLE, NC 27023  
434-688-0609 rllomas@rlomaspe.com

Luis R. Lomas P.E.  
FL No.: 62514

REVISIONS			
REV	DESCRIPTION	DATE	APPROVED
H	ADDED TRIMS & 5180 HOT MELT BUTYL	08/24/2021	R.L.

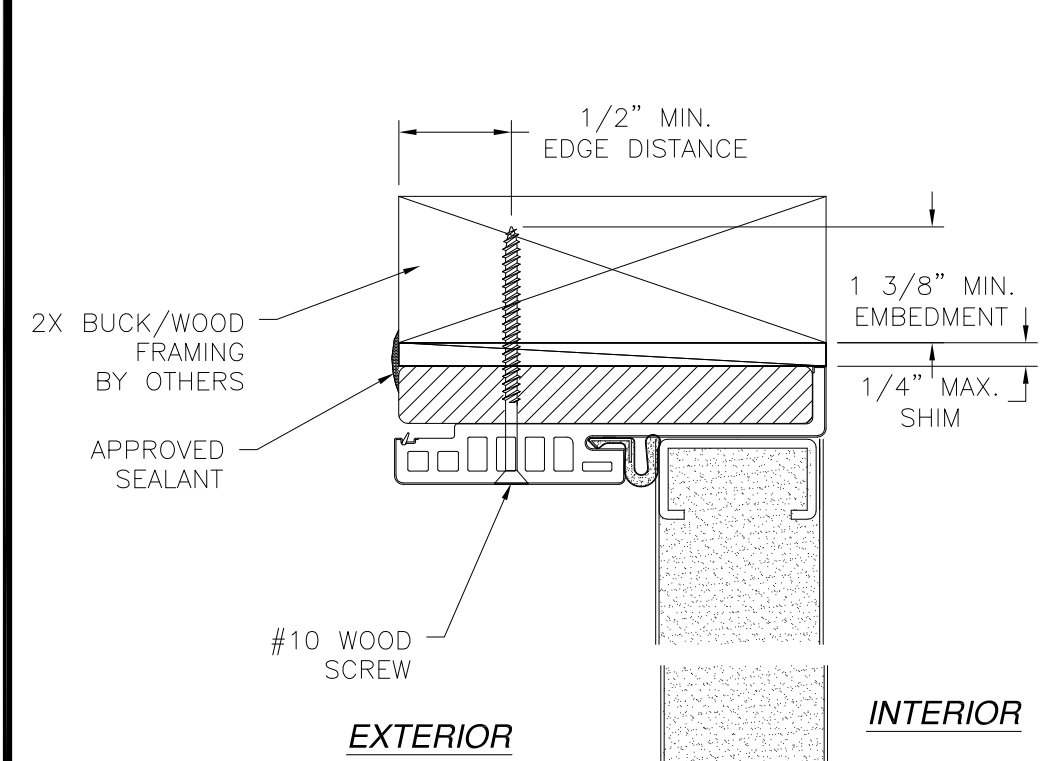

**EXTERIOR**

**INTERIOR**

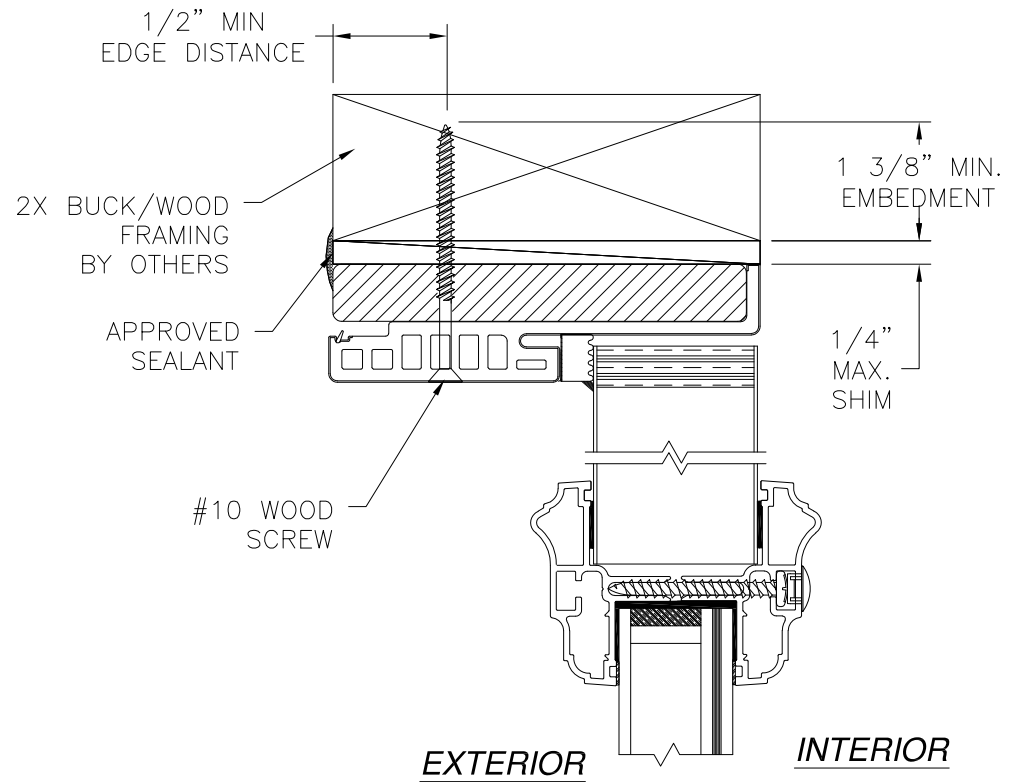

**EXTERIOR**

**INTERIOR**

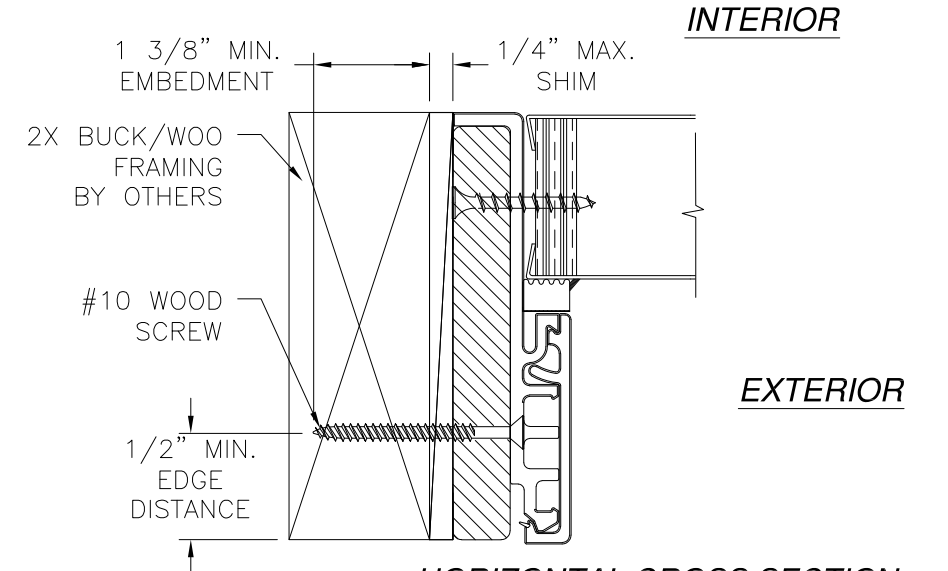

**INTERIOR**

**EXTERIOR**

**HORIZONTAL CROSS SECTION  
SIDELITE INSTALLATION 2X BUCK/WOOD FRAMING  
STANDARD SIDELITE SHOWN  
DIRECT SET SIDELITE SIMILAR**

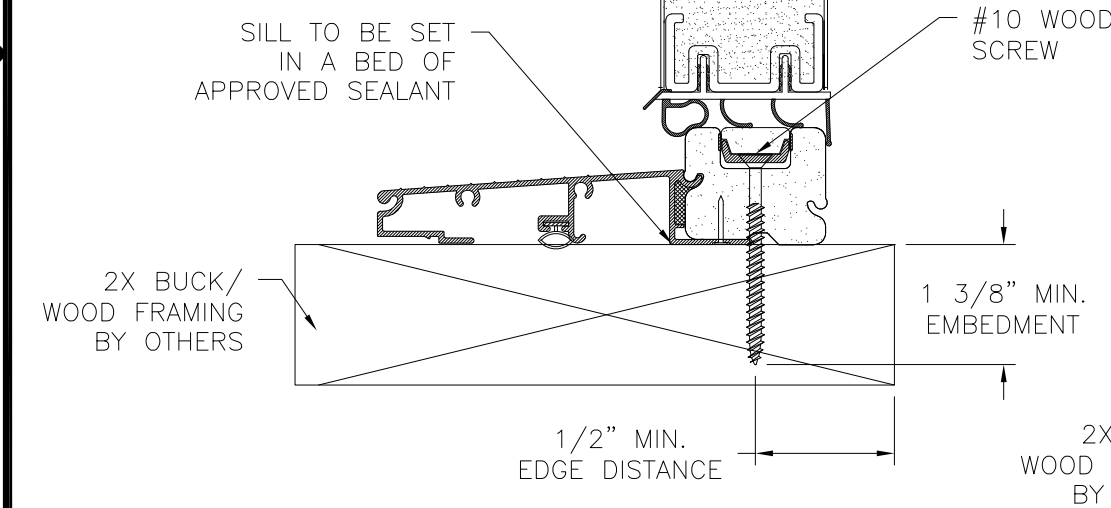

**VERTICAL CROSS SECTION  
DOOR INSTALLATION - 2X BUCK/WOOD FRAMING**

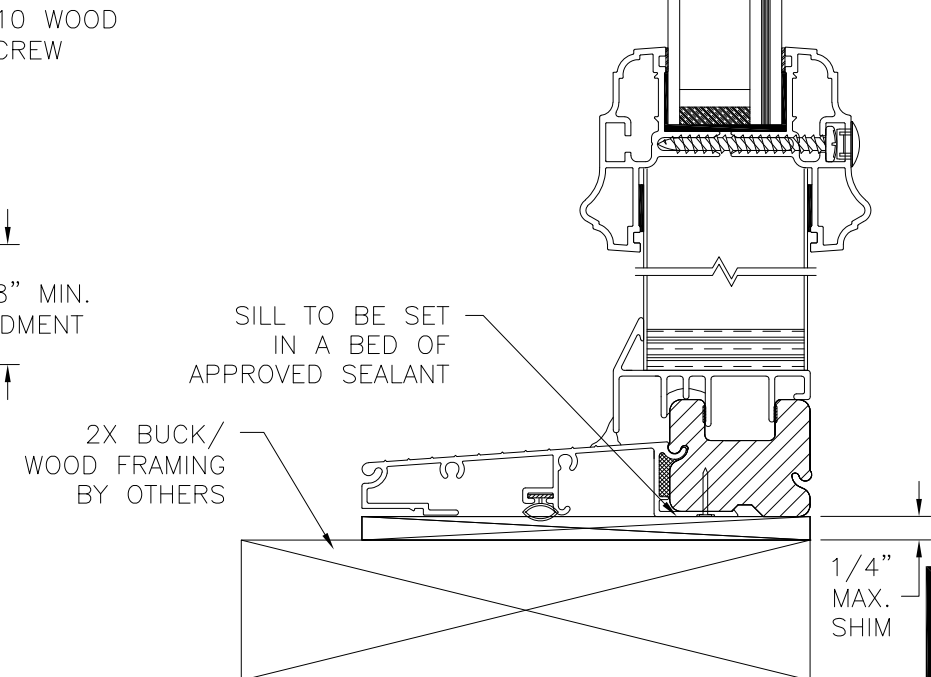

**VERTICAL CROSS SECTION  
SIDELITE INSTALLATION 2X BUCK/WOOD FRAMING  
STANDARD SIDELITE SHOWN  
DIRECT SET SIDELITE SIMILAR**

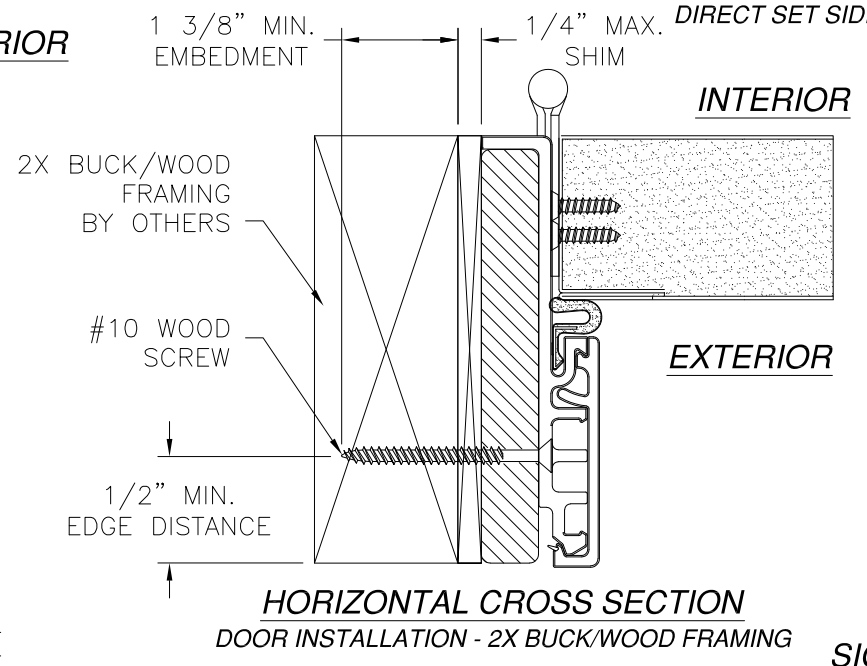

**INTERIOR**

**EXTERIOR**

**HORIZONTAL CROSS SECTION  
DOOR INSTALLATION - 2X BUCK/WOOD FRAMING**

SIGNED: 09/08/2021

- NOTES:**
1. INTERIOR AND EXTERIOR FINISHES, BY OTHERS, NOT SHOWN FOR CLARITY.
  2. PERIMETER AND JOINT SEALANT BY OTHERS TO BE DESIGNED IN ACCORDANCE WITH ASTM E2112

PROVIA, LLC.  
2150 STATE ROUTE 39 WEST  
SUGARCREEK, OH 44681

STEEL/FIBERGLASS INSWING OPAQUE DOUBLE DOOR  
W/SIDELITES - IMPACT  
INSTALLATION DETAILS W/FUSION FRAME

DRAWN: V.L.	DWG NO. 08-02038	REV H
SCALE NTS	DATE 04/22/13	SHEET 8 OF 16

L. ROBERTO LOMAS P.E.  
1432 WOODFORD RD LEWISVILLE, NC 27023  
434-688-0609 rllomas@rlomaspe.com

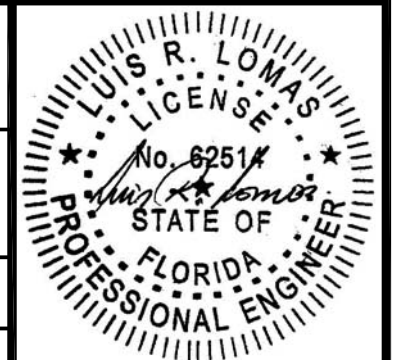

Luis R. Lomas P.E.  
FL No.: 62514



REVISIONS			
REV	DESCRIPTION	DATE	APPROVED
H	ADDED TRIMS & 5180 HOT MELT BUTYL	08/24/2021	R.L.

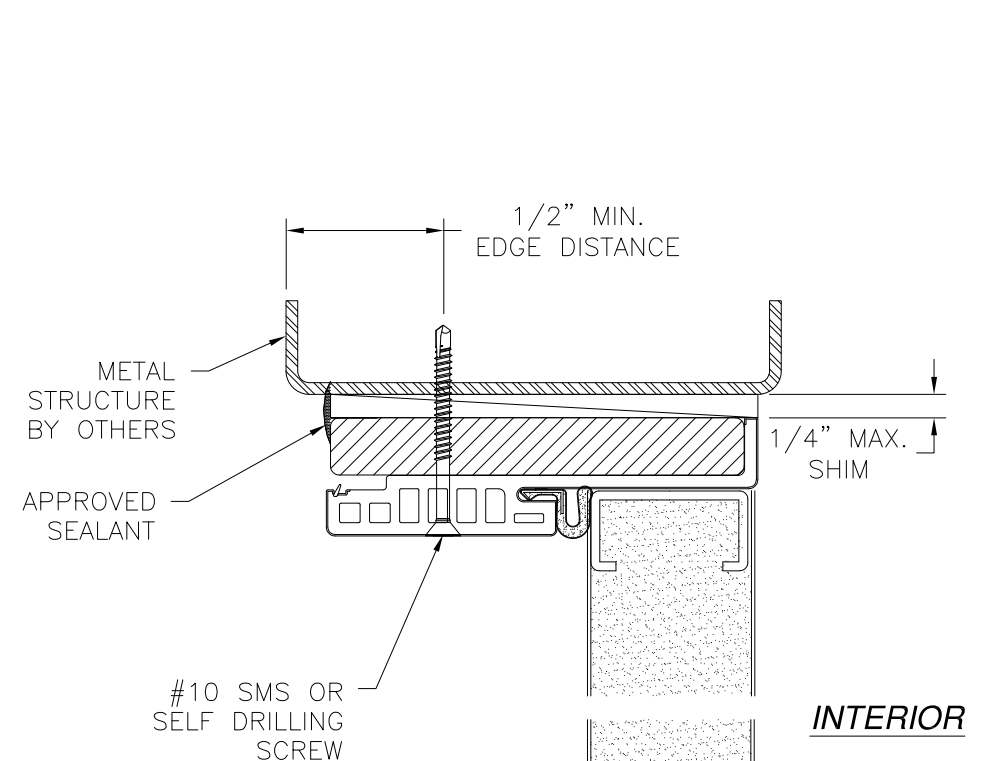

**VERTICAL CROSS SECTION**  
DOOR INSTALLATION - METAL STRUCTURE

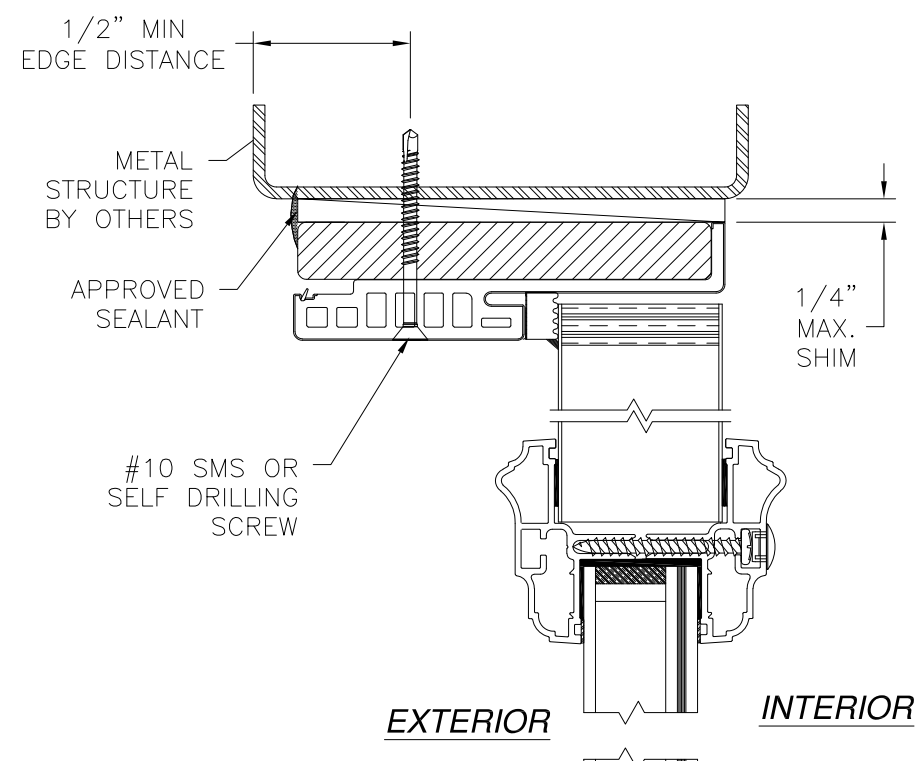

**VERTICAL CROSS SECTION**  
SIDELITE INSTALLATION METAL STRUCTURE  
STANDARD SIDELITE SHOWN  
DIRECT SET SIDELITE SIMILAR

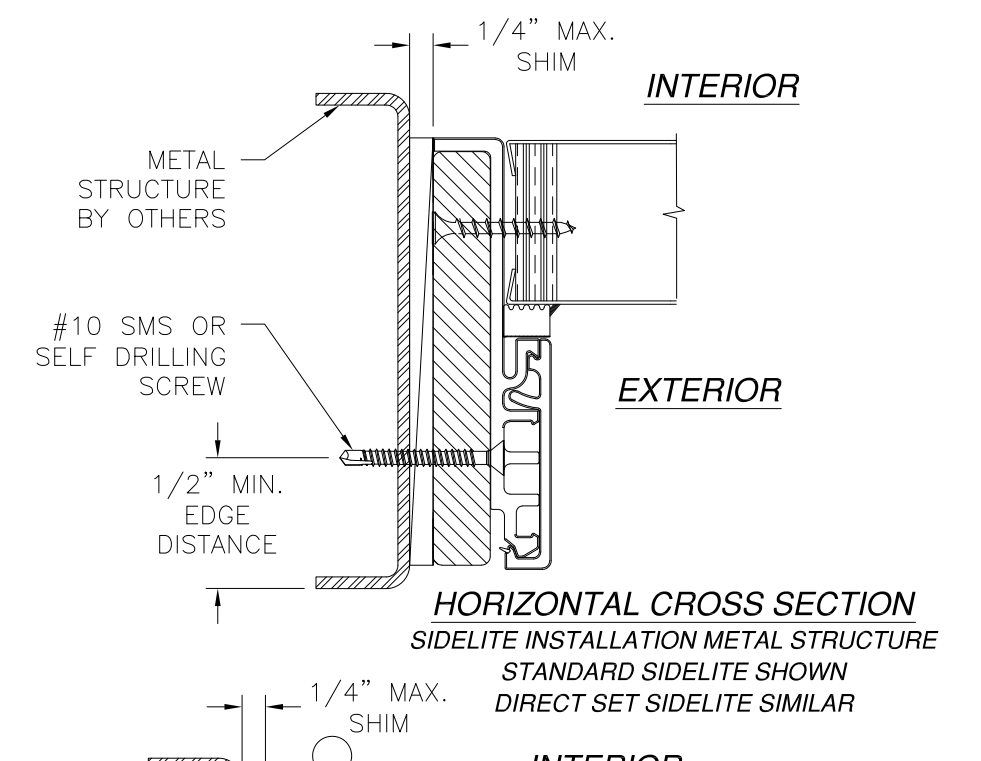

**HORIZONTAL CROSS SECTION**  
SIDELITE INSTALLATION METAL STRUCTURE  
STANDARD SIDELITE SHOWN  
DIRECT SET SIDELITE SIMILAR

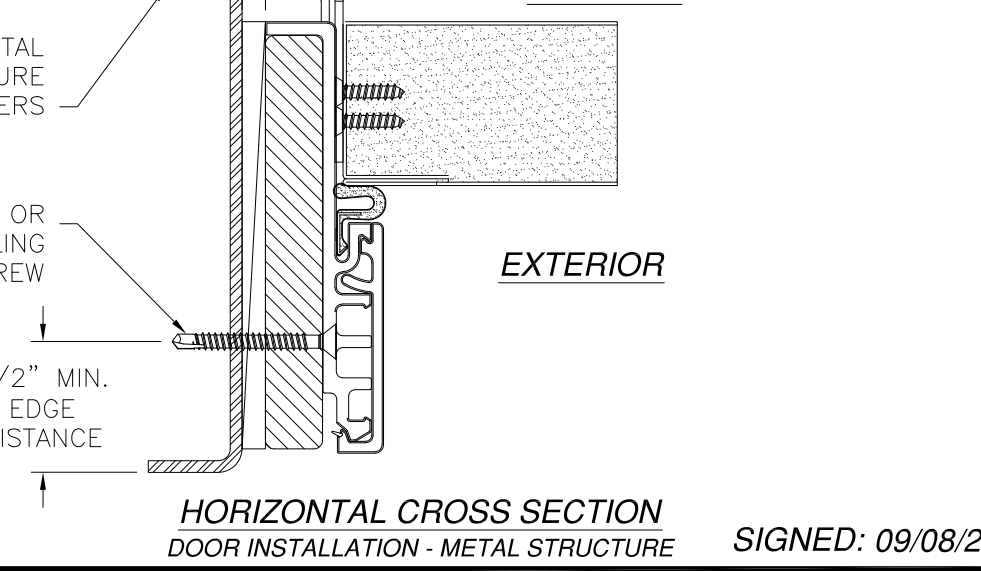

**HORIZONTAL CROSS SECTION**  
DOOR INSTALLATION - METAL STRUCTURE

- NOTES:**
1. INTERIOR AND EXTERIOR FINISHES, BY OTHERS, NOT SHOWN FOR CLARITY.
  2. PERIMETER AND JOINT SEALANT BY OTHERS TO BE DESIGNED IN ACCORDANCE WITH ASTM E2112

PROVIA, LLC.  
2150 STATE ROUTE 39 WEST  
SUGARCREEK, OH 44681

STEEL/FIBERGLASS INSWING OPAQUE DOUBLE DOOR  
W/SIDELITES - IMPACT  
INSTALLATION DETAILS W/FUSION FRAME

DRAWN: V.L.	DWG NO. 08-02038	REV H
SCALE NTS	DATE 04/22/13	SHEET 9 OF 16

L. ROBERTO LOMAS P.E.  
1432 WOODFORD RD LEWISVILLE, NC 27023  
434-688-0609 rllomas@rlomaspe.com

SIGNED: 09/08/2021

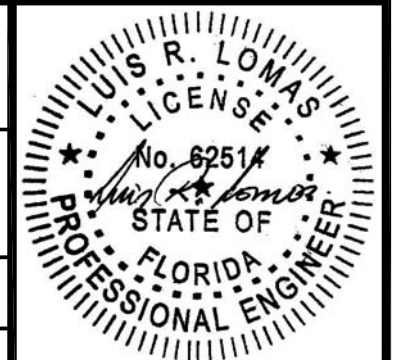

Luis R. Lomas P.E.  
FL No.: 62514

REVISIONS			
REV	DESCRIPTION	DATE	APPROVED
H	ADDED TRIMS & 5180 HOT MELT BUTYL	08/24/2021	R.L.

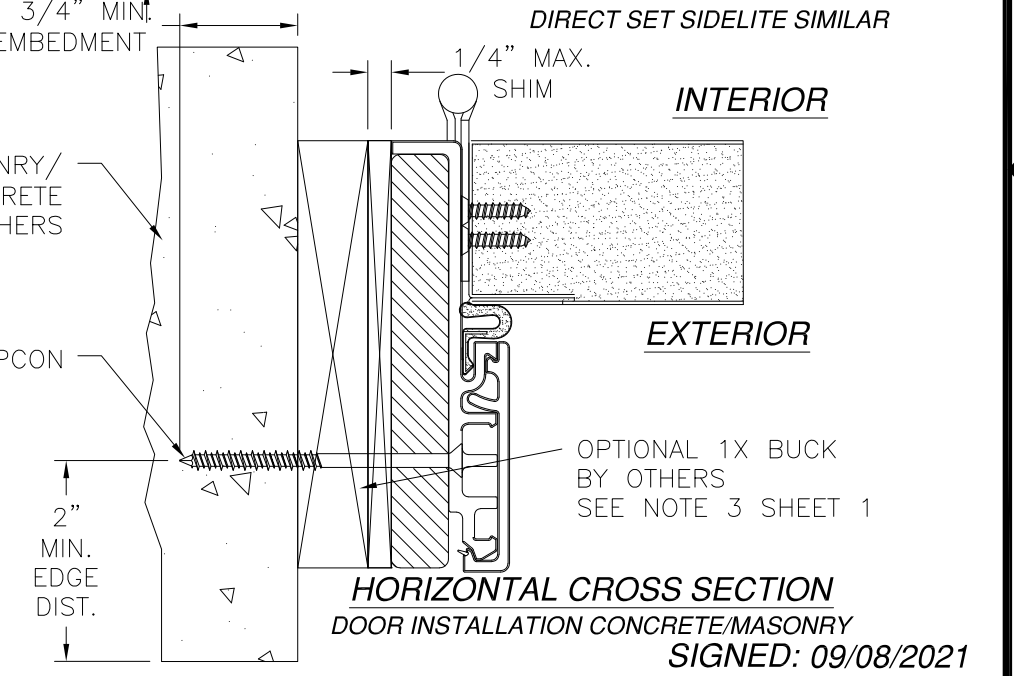
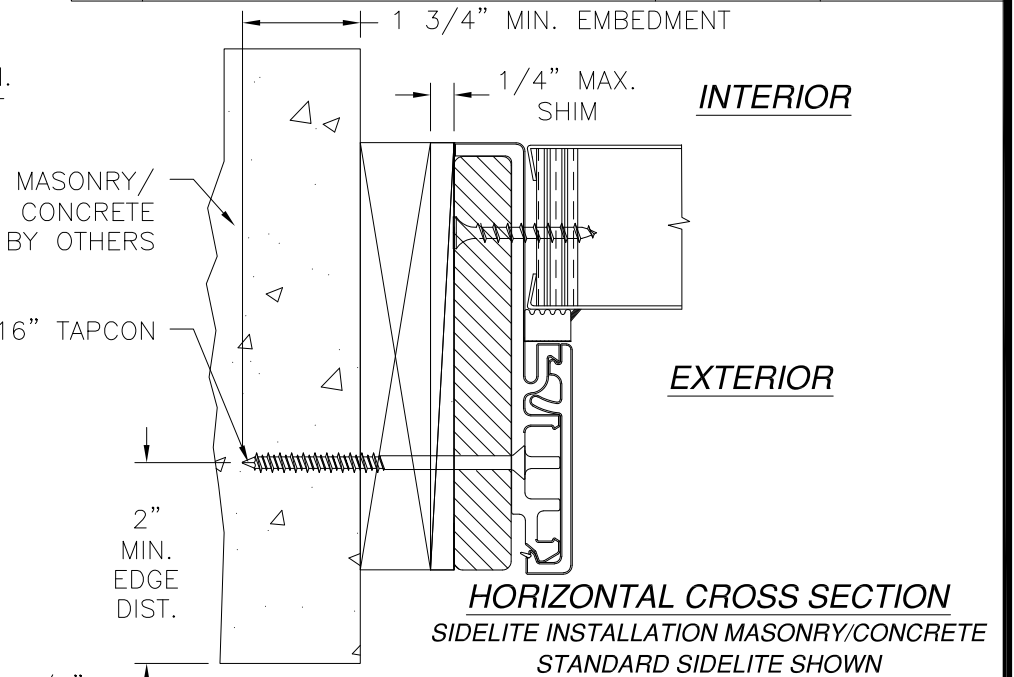
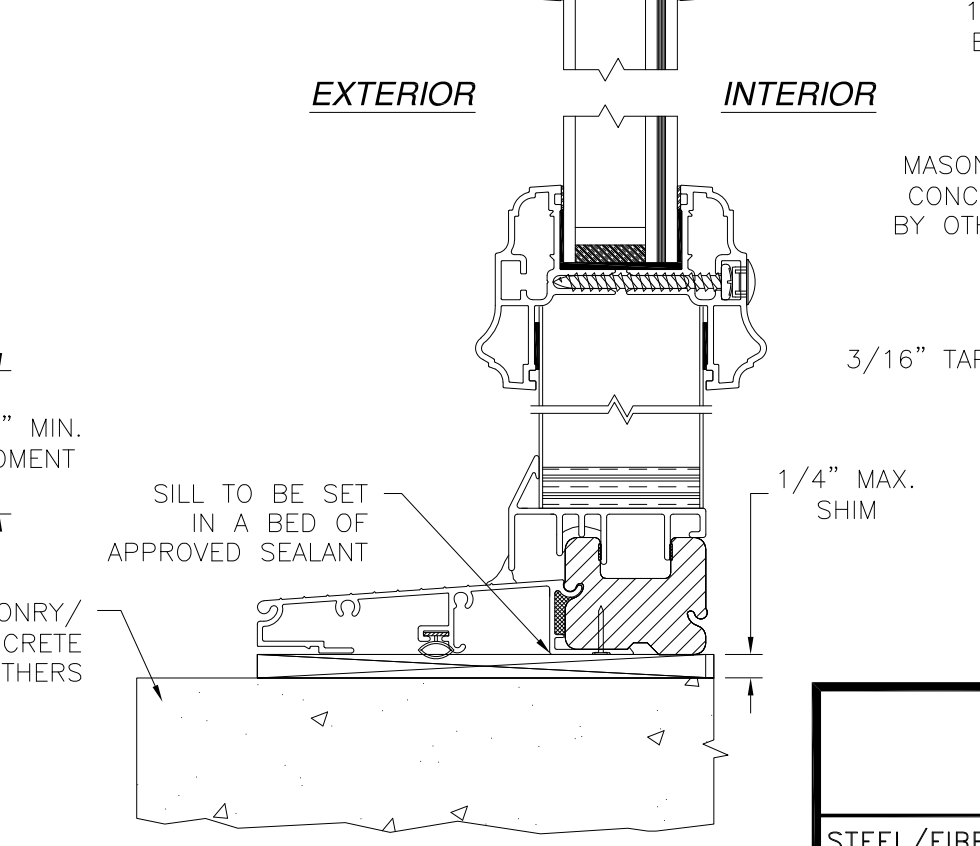
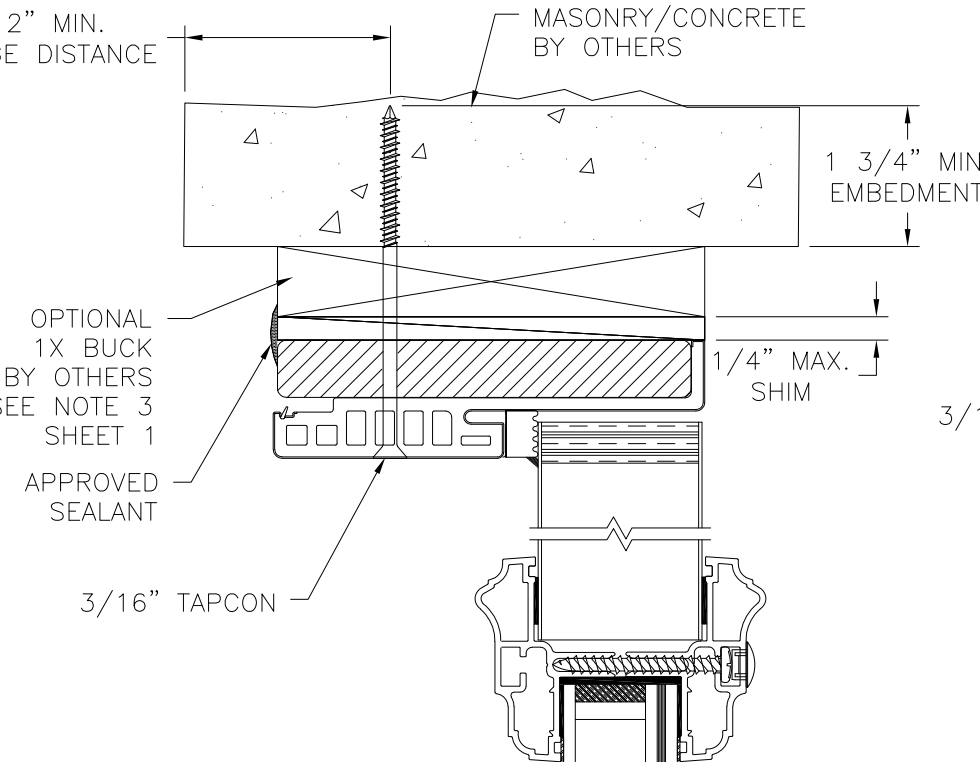
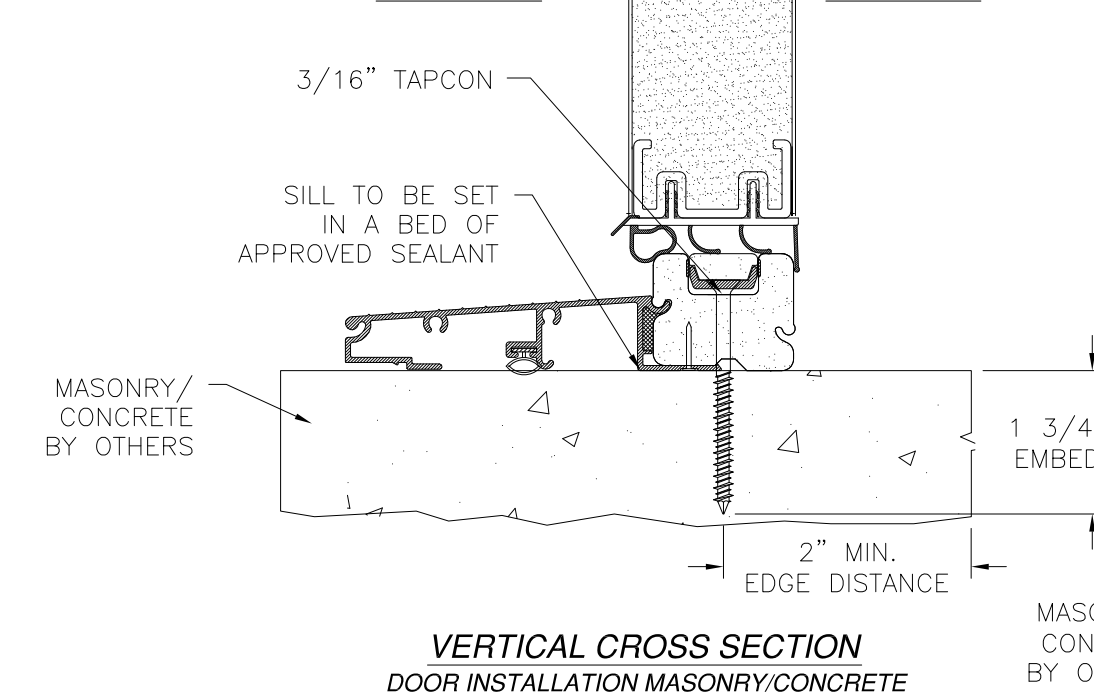
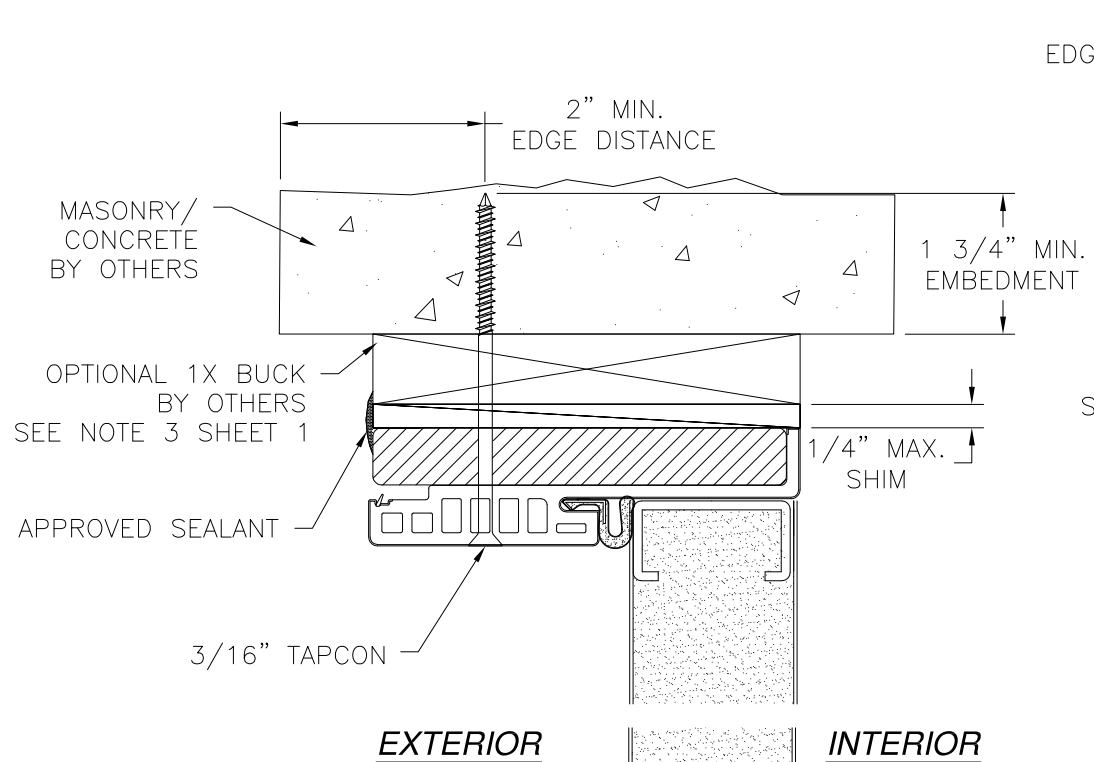

- NOTES:**
1. INTERIOR AND EXTERIOR FINISHES, BY OTHERS, NOT SHOWN FOR CLARITY.
  2. PERIMETER AND JOINT SEALANT BY OTHERS TO BE DESIGNED IN ACCORDANCE WITH ASTM E2112

PROVIA, LLC.  
2150 STATE ROUTE 39 WEST  
SUGARCREEK, OH 44681

STEEL/FIBERGLASS INSWING OPAQUE DOUBLE DOOR  
W/SIDELITES - IMPACT  
INSTALLATION DETAILS W/FUSION FRAME

DRAWN: V.L.	DWG NO. 08-02038	REV H
SCALE NTS	DATE 04/22/13	SHEET 10 OF 16

L. ROBERTO LOMAS P.E.  
1432 WOODFORD RD LEWISVILLE, NC 27023  
434-688-0609 rllomas@rlomaspe.com

Luis R. Lomas P.E.  
FL No.: 62514

REVISIONS			
REV	DESCRIPTION	DATE	APPROVED
H	ADDED TRIMS & 5180 HOT MELT BUTYL	08/24/2021	R.L.

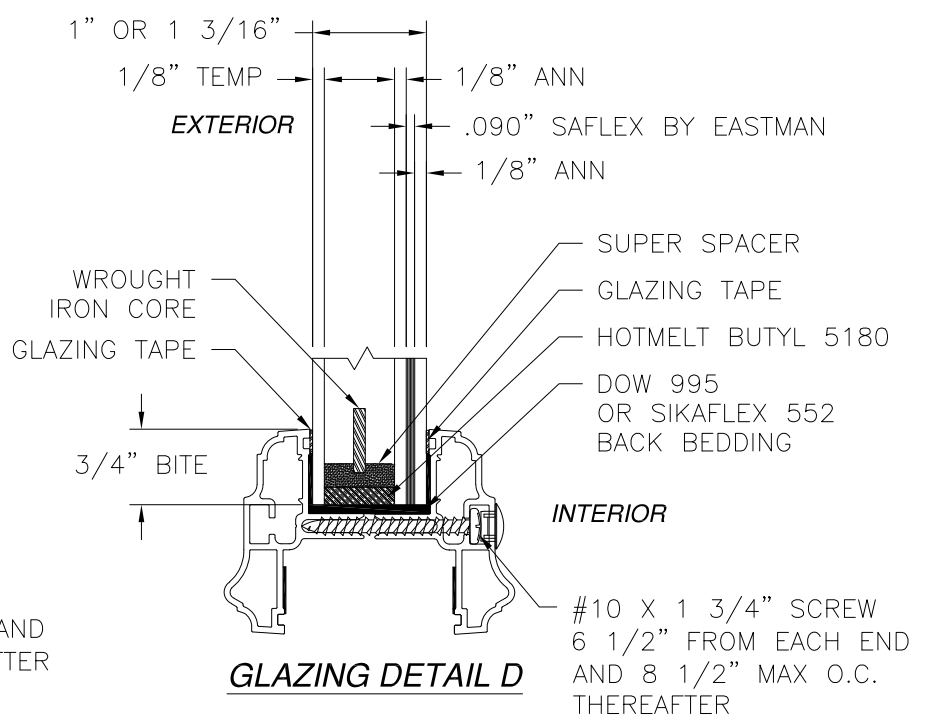
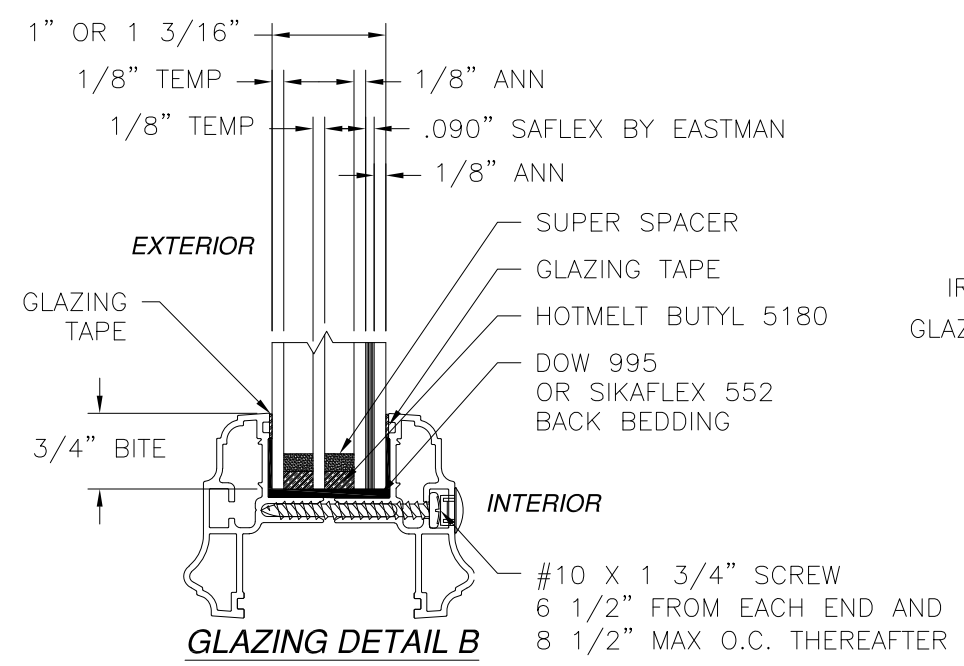
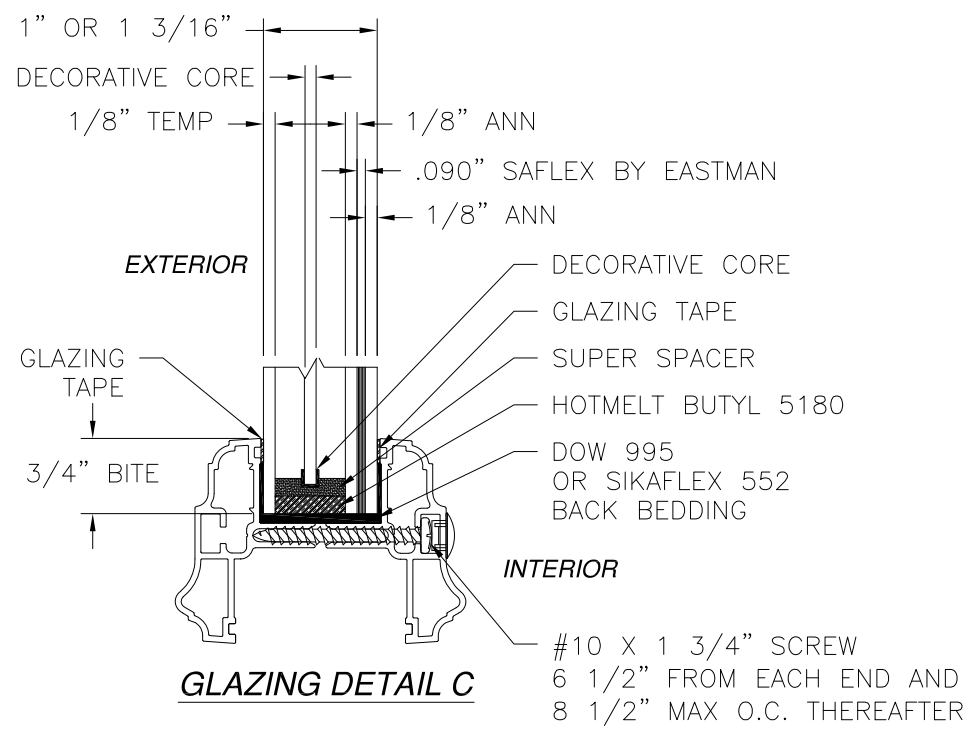
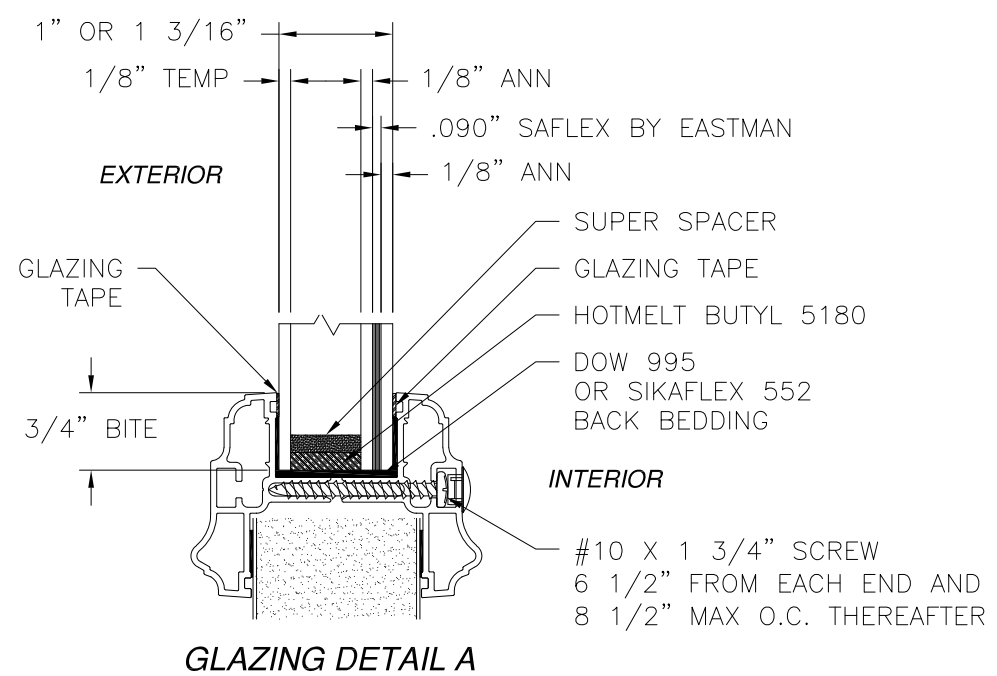

PROVIA, LLC.  
2150 STATE ROUTE 39 WEST  
SUGARCREEK, OH 44681

STEEL/FIBERGLASS INSWING OPAQUE DOUBLE DOOR  
W/SIDELITES - IMPACT  
GLAZING DETAILS

DRAWN: V.L. DWG NO. 08-02038 REV H

SCALE NTS DATE 04/22/13 SHEET 11 OF 16

L. ROBERTO LOMAS P.E.  
1432 WOODFORD RD LEWISVILLE, NC 27023  
434-688-0609 rllomas@rlomaspe.com

SIGNED: 09/08/2021



Luis R. Lomas P.E.  
FL No.: 62514

REVISIONS			
REV	DESCRIPTION	DATE	APPROVED
H	ADDED TRIMS & 5180 HOT MELT BUTYL	08/24/2021	R.L.

### APPROVED SIDELITE SLABS

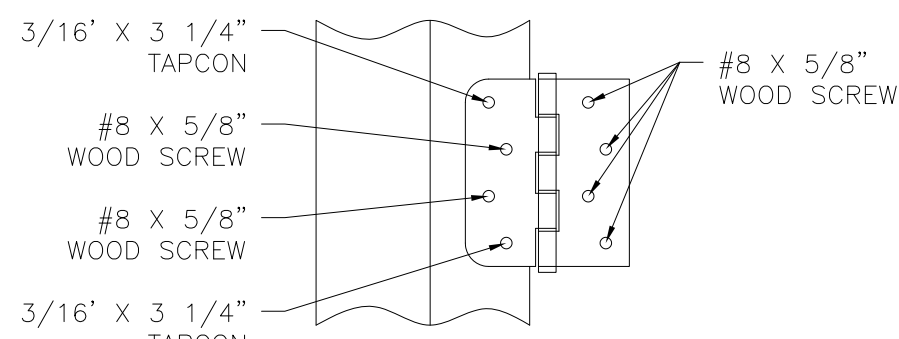

**HINGE INSTALLATION DETAIL**  
MASONRY/CONCRETE

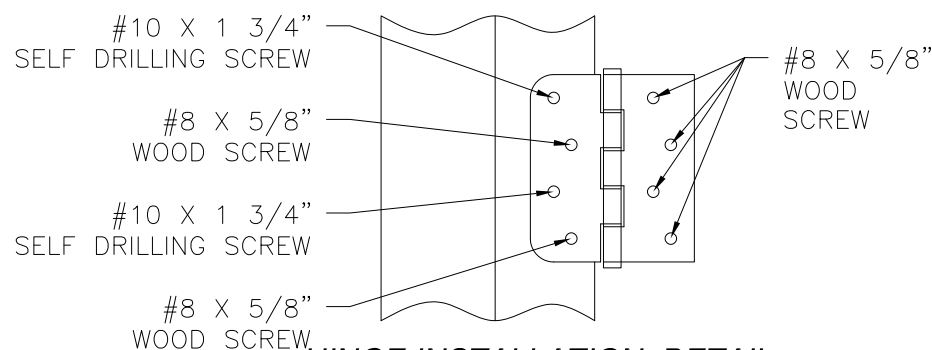

**HINGE INSTALLATION DETAIL**  
METAL STRUCTURE

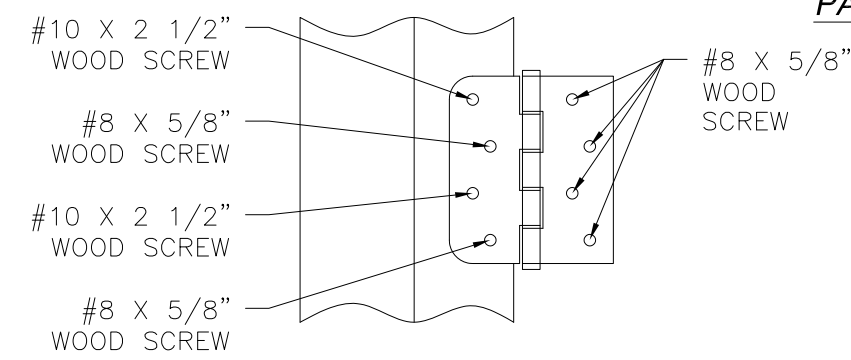

**HINGE INSTALLATION DETAIL**  
2X BUCK/WOOD FRAMING

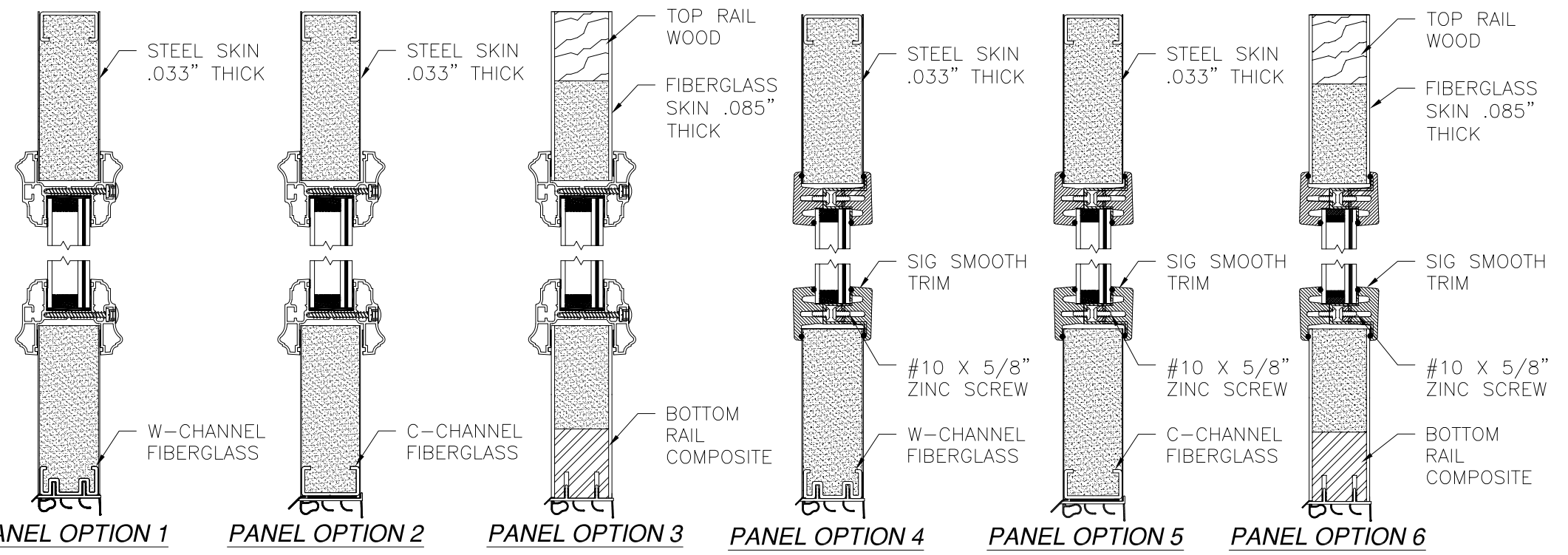

**PANEL OPTION 1**    **PANEL OPTION 2**    **PANEL OPTION 3**    **PANEL OPTION 4**    **PANEL OPTION 5**    **PANEL OPTION 6**

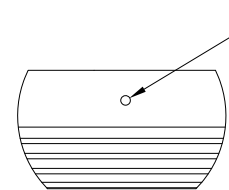

**ASTRAGAL SILL DETAIL**

ASTRAGAL BOLT HOLE MUST BE DRILLED THROUGH SILL AND INTO SUBSTRATE DEEP ENOUGH TO ACHIEVE 1 3/8" THROW

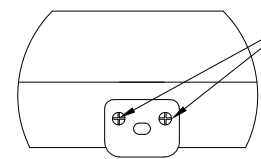

**ASTRAGAL HEAD STRIKE DETAIL**  
2X BUCK/WOOD FRAMING  
OR METAL STRUCTURE

#10 x 2 1/2" WOOD SCREW OR #10x1 1/2" SELF DRILLING SCREW

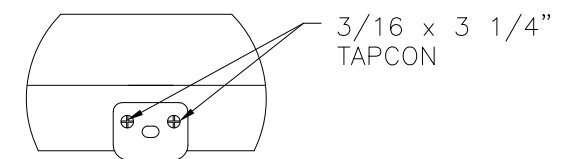

**ASTRAGAL HEAD STRIKE DETAIL**  
MASONRY/CONCRETE

3/16 x 3 1/4" TAPCON

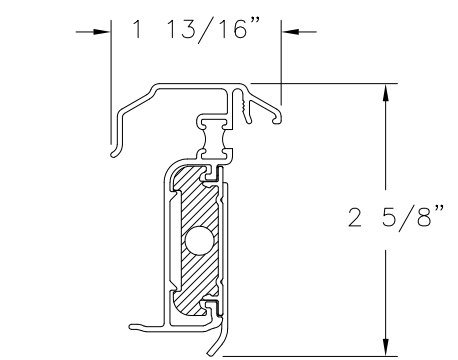

**HURRICANE ASTRAGAL DETAIL**

SIGNED: 09/08/2021

PROVIA, LLC.  
2150 STATE ROUTE 39 WEST  
SUGARCREEK, OH 44681

STEEL/FIBERGLASS INSWING OPAQUE DOUBLE DOOR  
W/SIDELITES - IMPACT  
COMPONENTS DETAILS

DRAWN: V.L.	DWG NO. 08-02038	REV H
SCALE NTS	DATE 04/22/13	SHEET 12 OF 16

L. ROBERTO LOMAS P.E.  
1432 WOODFORD RD LEWISVILLE, NC 27023  
434-688-0609 rllomas@rlomaspe.com

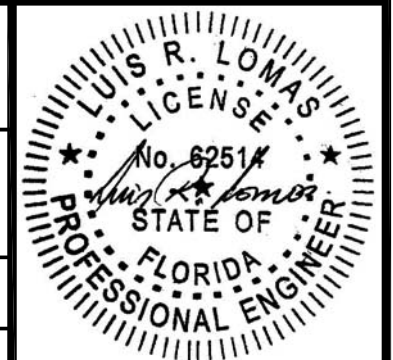

Luis R. Lomas P.E.  
FL No.: 62514

# APPROVED SIDELITE SLABS

REVISIONS			
REV	DESCRIPTION	DATE	APPROVED
H	ADDED TRIMS & 5180 HOT MELT BUTYL	08/24/2021	R.L.

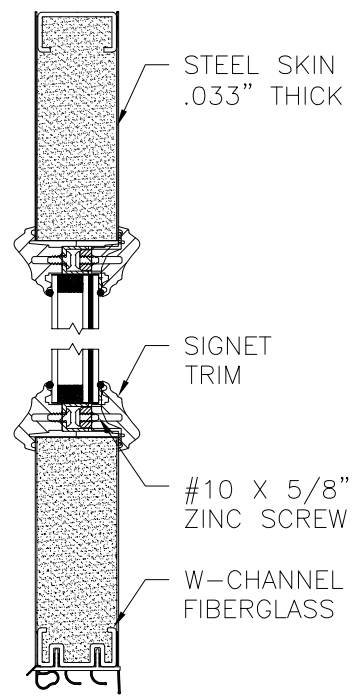

PANEL OPTION 7

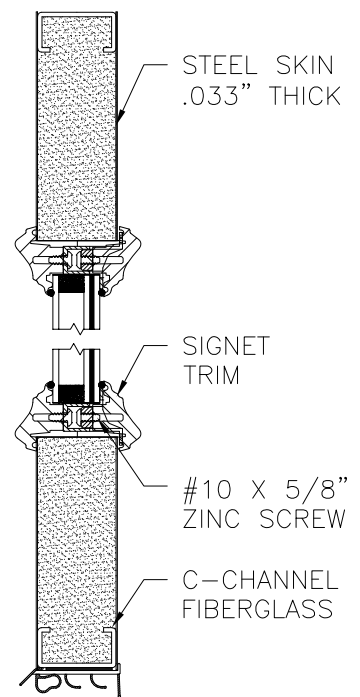

PANEL OPTION 8

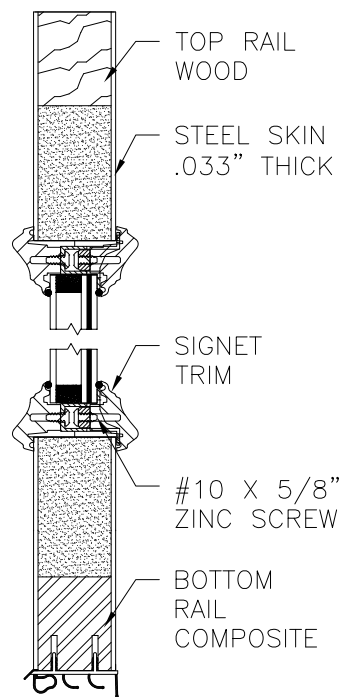

PANEL OPTION 9

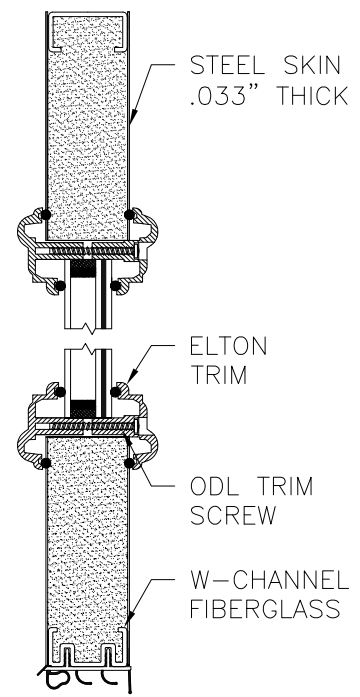

PANEL OPTION 10

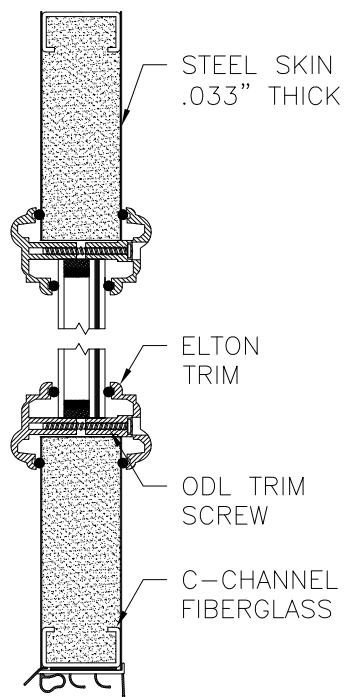

PANEL OPTION 11

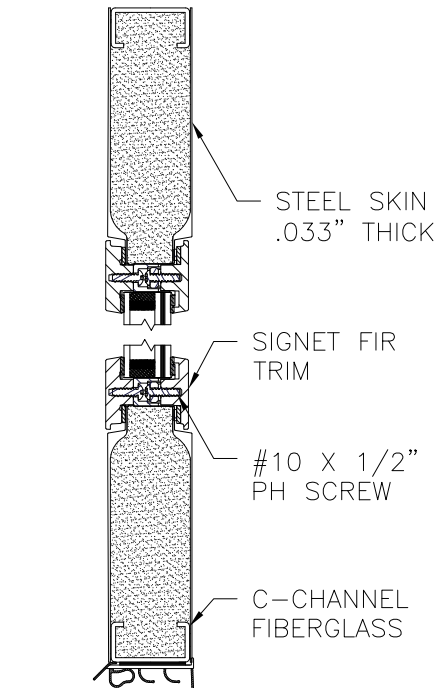

PANEL OPTION 17

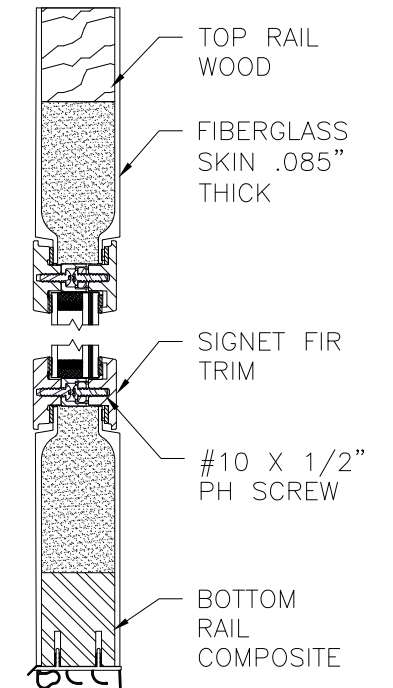

PANEL OPTION 18

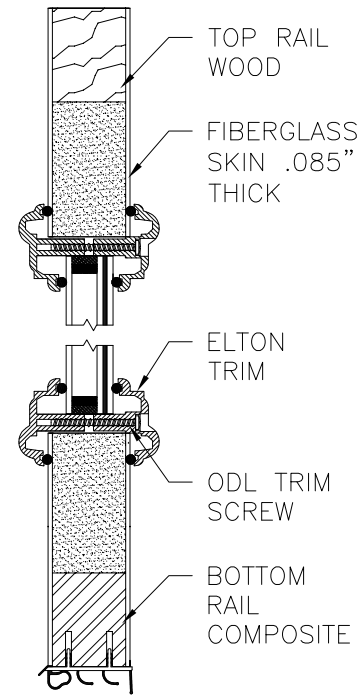

PANEL OPTION 12

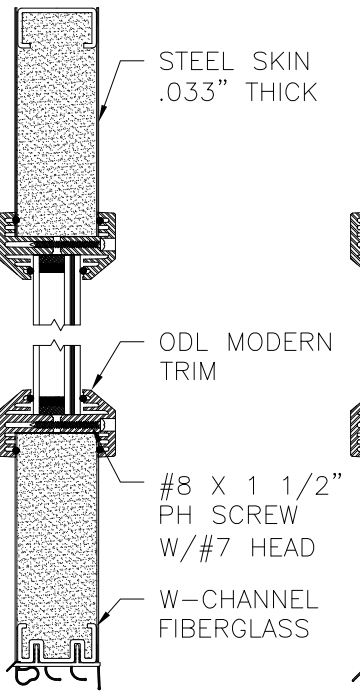

PANEL OPTION 13

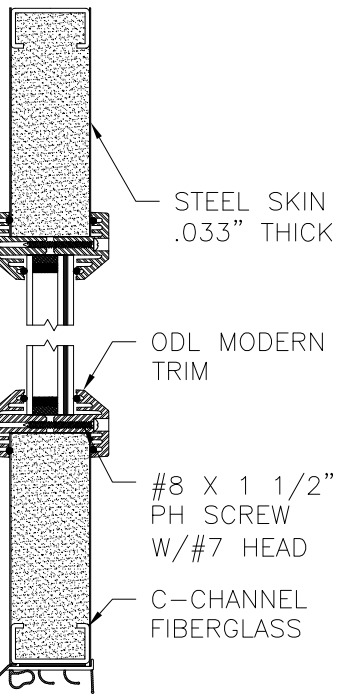

PANEL OPTION 14

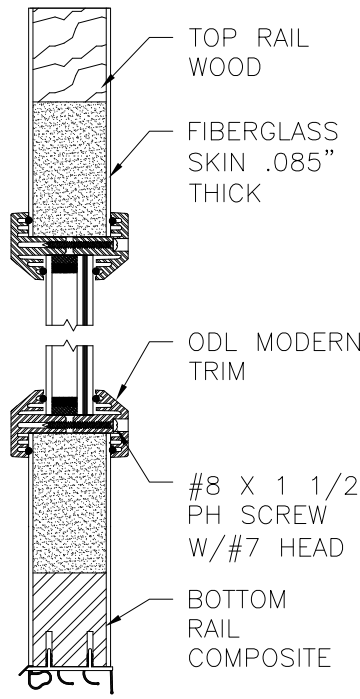

PANEL OPTION 15

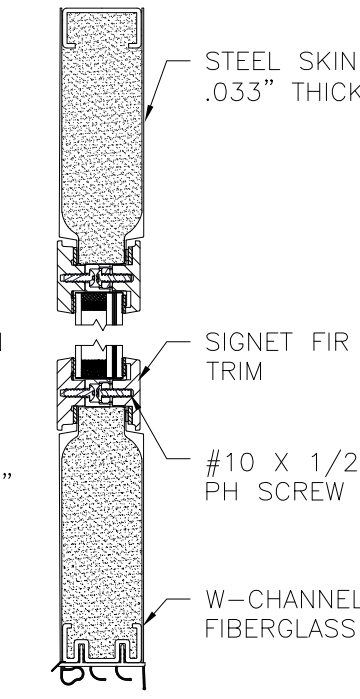

PANEL OPTION 16

SIGNED: 09/08/2021

PROVIA, LLC.  
 2150 STATE ROUTE 39 WEST  
 SUGARCREEK, OH 44681

STEEL/FIBERGLASS INSWING OPAQUE DOUBLE DOOR  
 W/SIDELITES - IMPACT  
 APPROVED SLABS

DRAWN: V.L.	DWG NO. 08-02038	REV H
SCALE NTS	DATE 04/22/13	SHEET 13 OF 16

L. ROBERTO LOMAS P.E.  
 1432 WOODFORD RD LEWISVILLE, NC 27023  
 434-688-0609 rllomas@rlomaspe.com

Luis R. Lomas P.E.  
 FL No.: 62514

# APPROVED DOOR SLABS AND CROSS SECTIONS

REVISIONS			
REV	DESCRIPTION	DATE	APPROVED
H	ADDED TRIMS & 5180 HOT MELT BUTYL	08/24/2021	R.L.

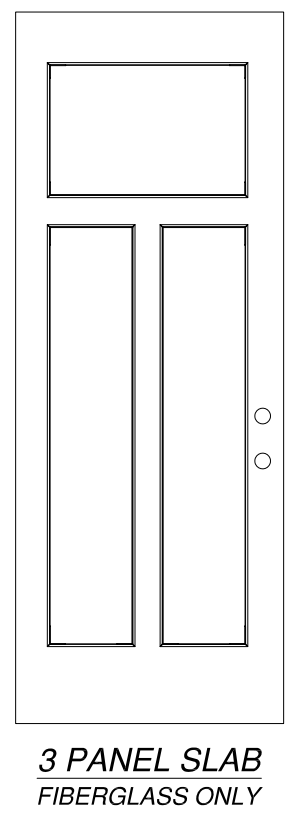
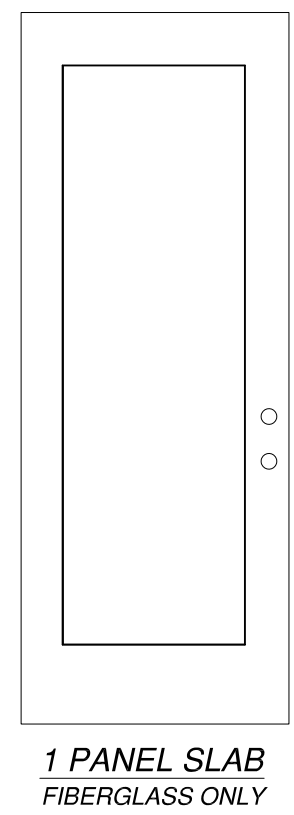
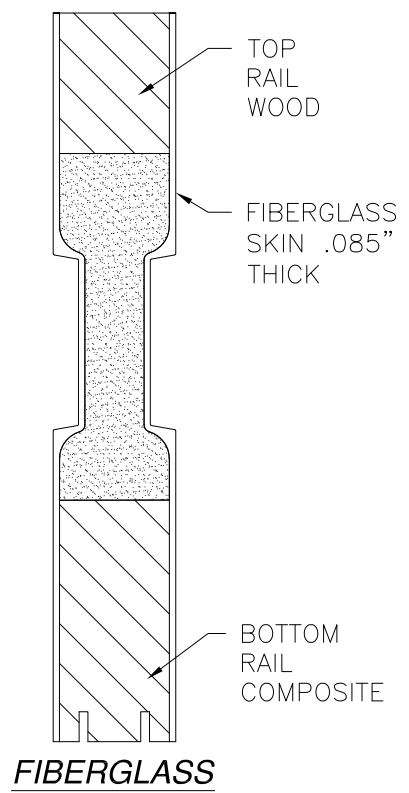
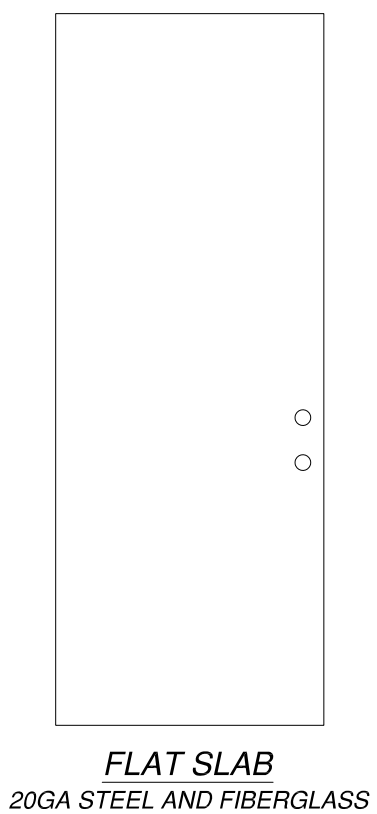
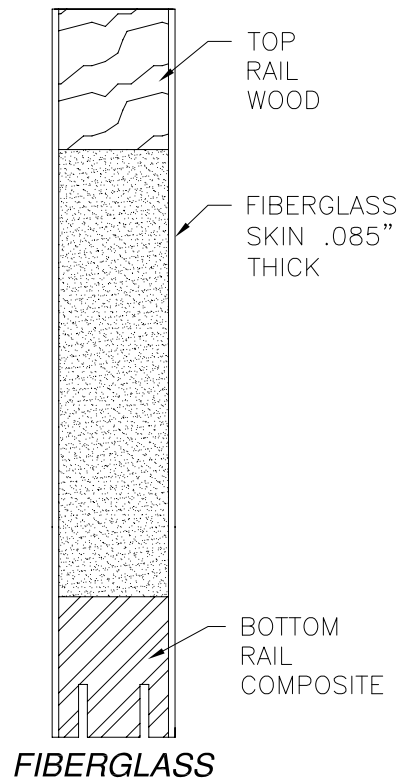
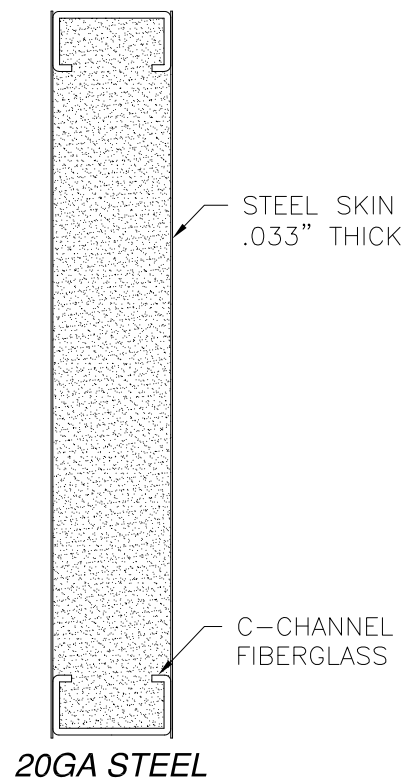
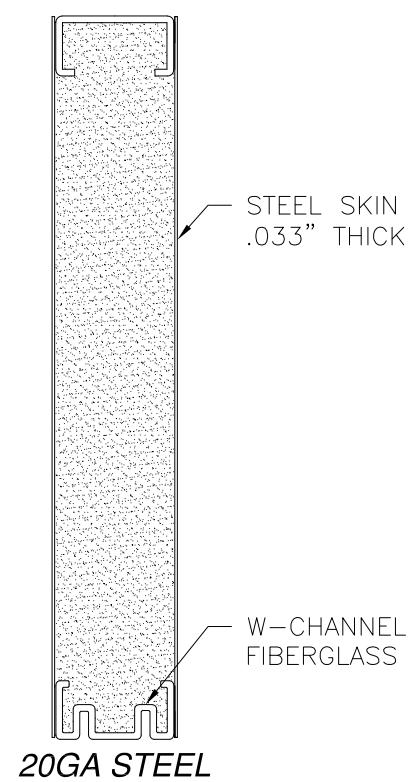

**PROVIA, LLC.**  
2150 STATE ROUTE 39 WEST  
SUGARCREEK, OH 44681

---

STEEL/FIBERGLASS INSWING OPAQUE DOUBLE DOOR  
W/SIDELITES - IMPACT  
APPROVED SLABS

DRAWN: V.L.	DWG NO. 08-02038	REV H
SCALE NTS	DATE 04/22/13	SHEET 14 OF 16

L. ROBERTO LOMAS P.E.  
1432 WOODFORD RD LEWISVILLE, NC 27023  
434-688-0609 rllomas@rlomaspe.com

SIGNED: 09/08/2021

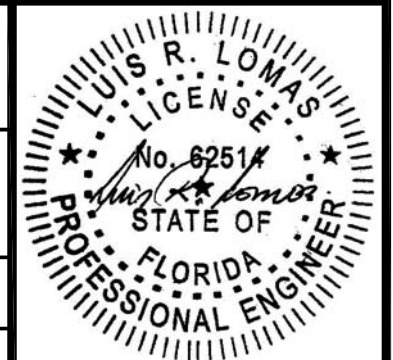

Luis R. Lomas P.E.  
FL No.: 62514

REVISIONS			
REV	DESCRIPTION	DATE	APPROVED
H	ADDED TRIMS & 5180 HOT MELT BUTYL	08/24/2021	R.L.

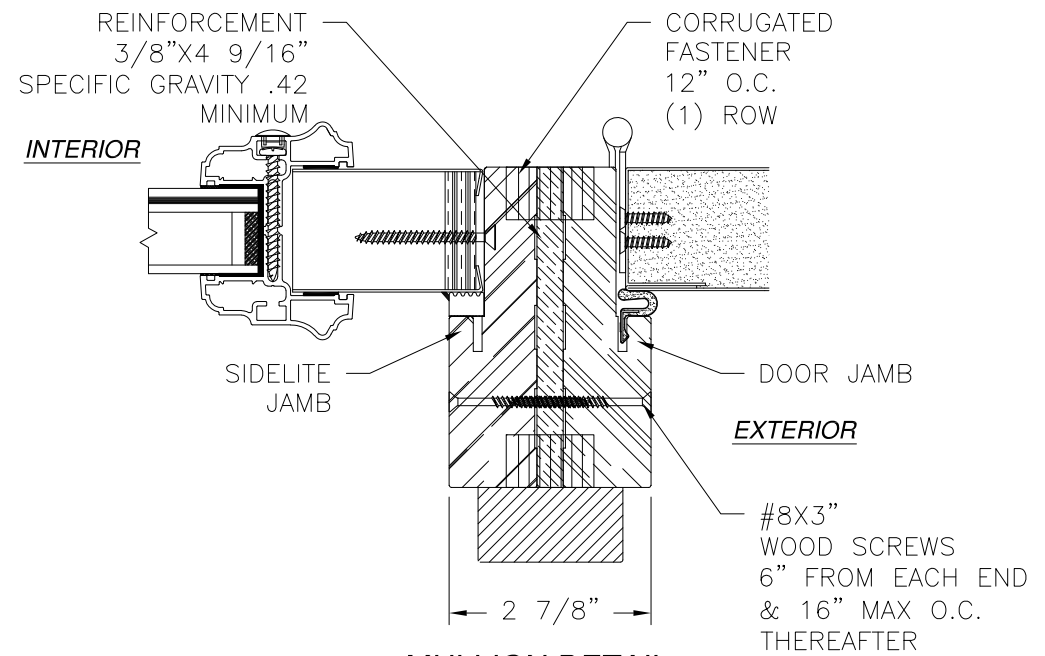

**MULLION DETAIL**

STANDARD FRAME SHOWN,  
COMPOSITE AND FUSION FRAME SIMILAR

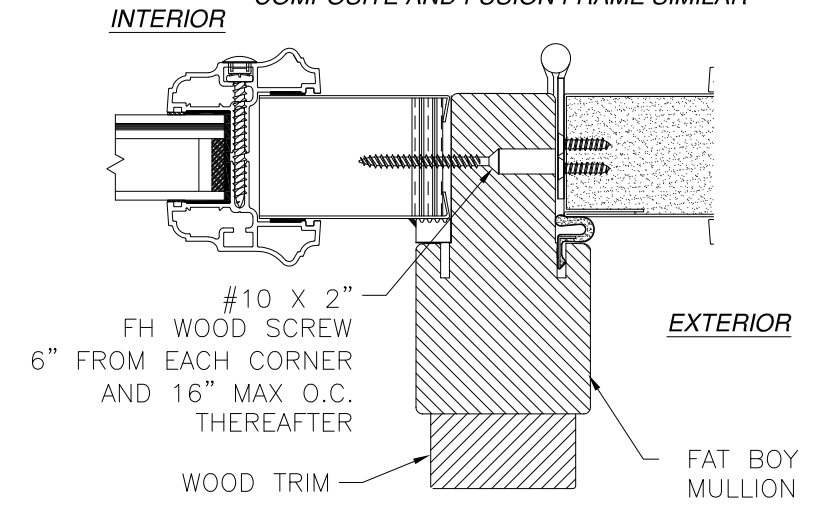

**MULLION DETAIL**

WITH FAT BOY MULLION

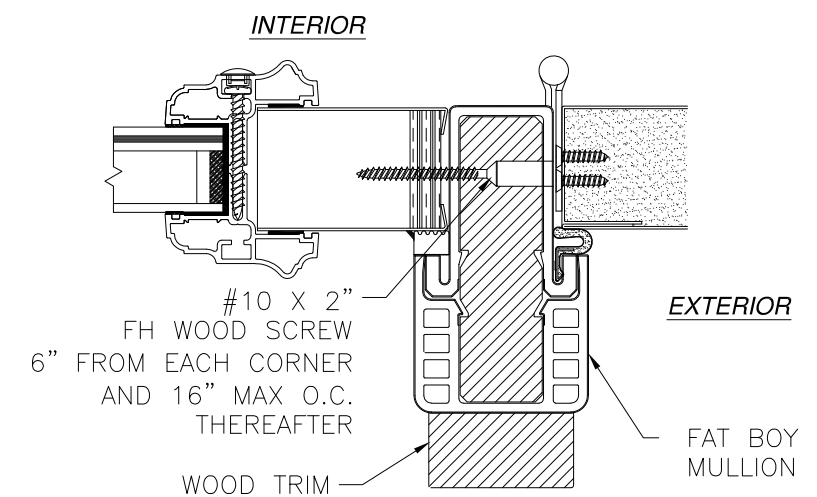

**MULLION DETAIL**

WITH HYBRID FAT BOY MULLION

**PROVIA, LLC.**  
2150 STATE ROUTE 39 WEST  
SUGARCREEK, OH 44681

---

STEEL/FIBERGLASS INSWING OPAQUE DOUBLE DOOR  
W/SIDELITES - IMPACT  
MULLION DETAILS

DRAWN: V.L.	DWG NO. 08-02038	REV H
SCALE NTS	DATE 04/22/13	SHEET 15 OF 16

L. ROBERTO LOMAS P.E.  
1432 WOODFORD RD LEWISVILLE, NC 27023  
434-688-0609 rllomas@rlomaspe.com

SIGNED: 09/08/2021

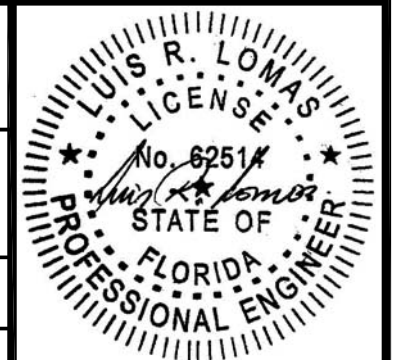

Luis R. Lomas P.E.  
FL No.: 62514

REVISIONS			
REV	DESCRIPTION	DATE	APPROVED
H	ADDED TRIMS & 5180 HOT MELT BUTYL	08/24/2021	R.L.

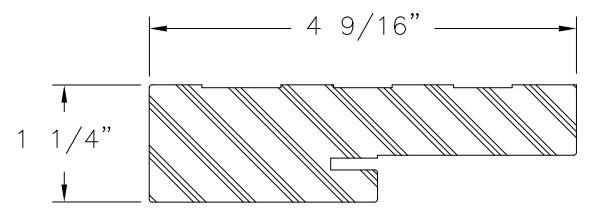

**COMPOSITE FRAME PROFILE**

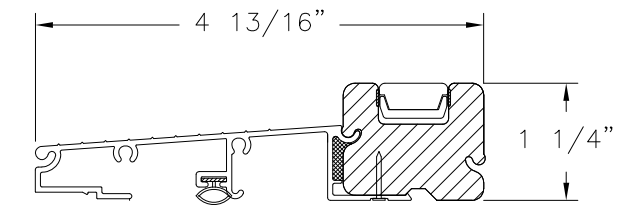

**SAHARA INSWING THRESHOLD**

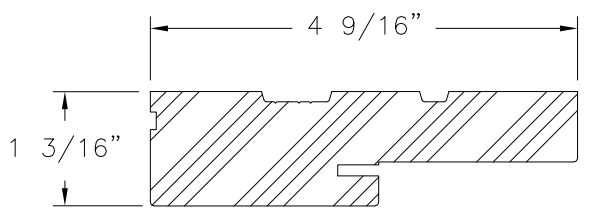

**WOOD FRAME PROFILE**

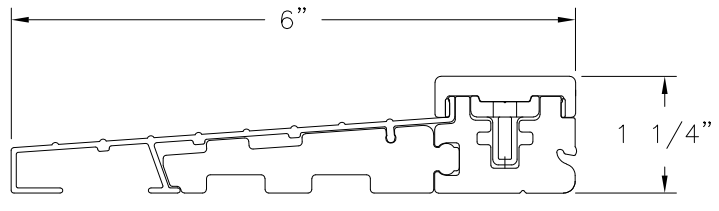

**STANDARD INSWING THRESHOLD**

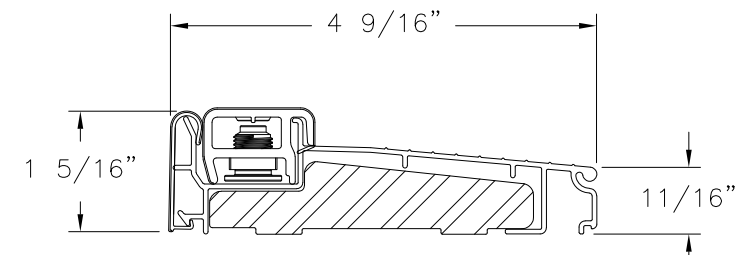

**INSWING SILL ZAIL4565**

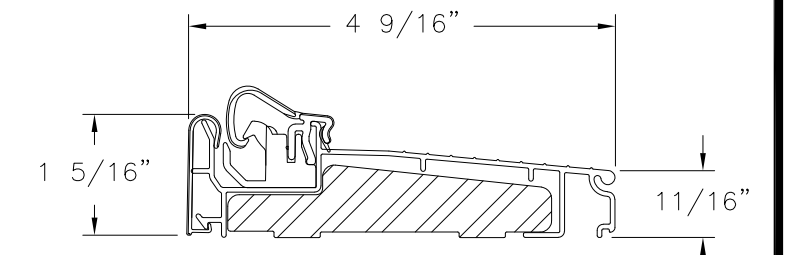

**INSWING SILL ZAACL4565**

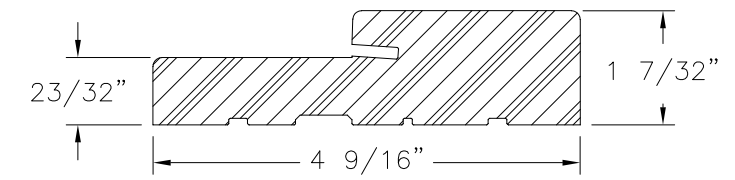

**FRAMESAVER COMPOSITE**

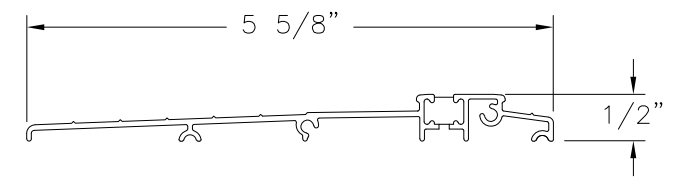

**ADA THRESHOLD**

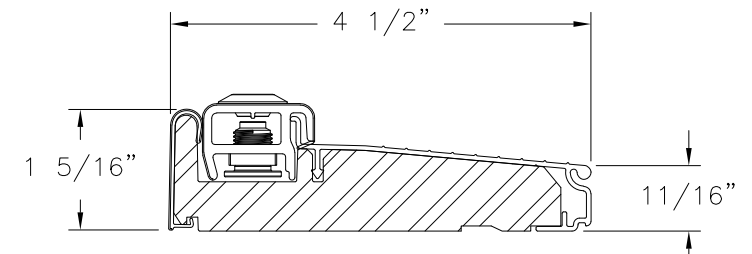

**INSWING SILL ZAI4565F**

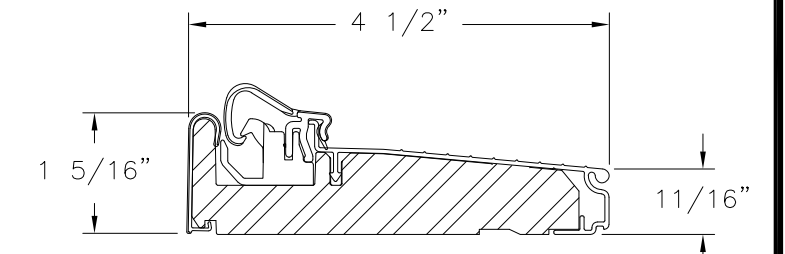

**INSWING SILL ZAC4565F**

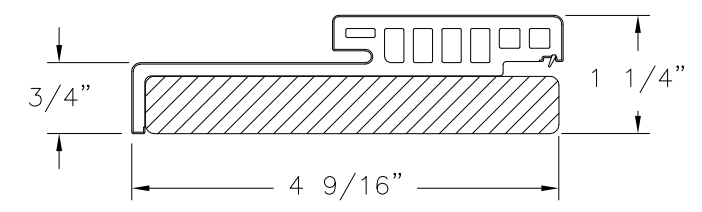

**HYBRID HEAD WOOD/COMPOSITE**

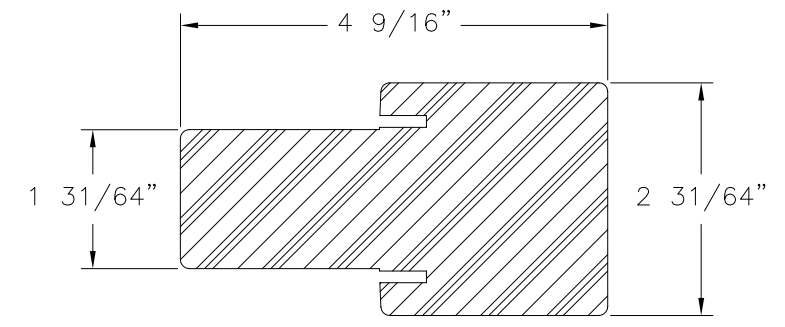

**FAT BOY MULLION COMPOSITE**

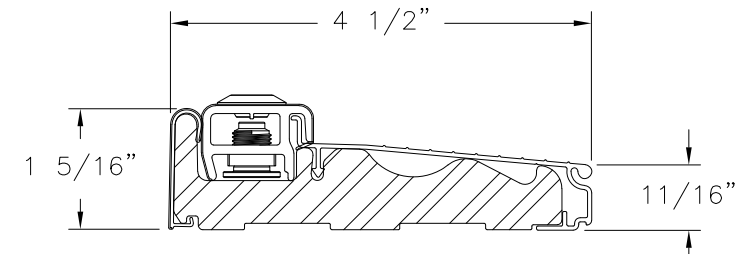

**INSWING SILL ZAILH4565**

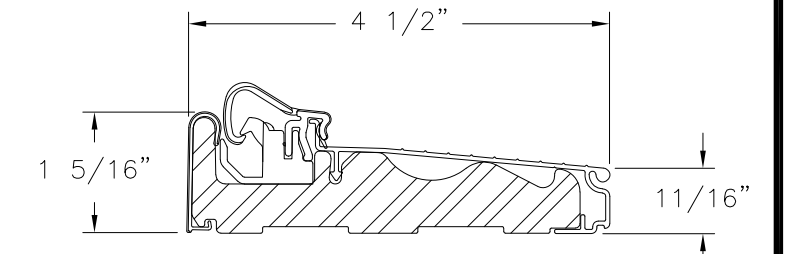

**INSWING SILL ZAACLH4565**

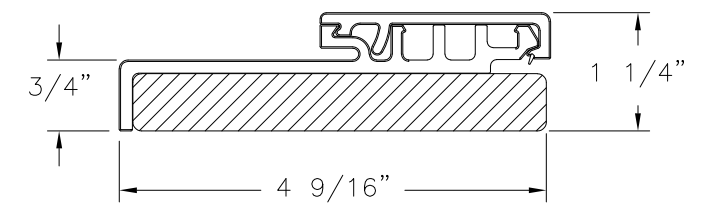

**HYBRID JAMB WOOD/COMPOSITE**

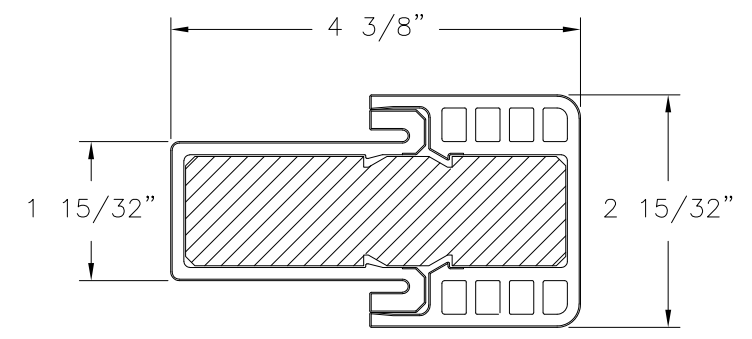

**HYBRID FAT BOY MULLION COMPOSITE**

PROVIA, LLC.  
 2150 STATE ROUTE 39 WEST  
 SUGARCREEK, OH 44681

STEEL/FIBERGLASS INSWING OPAQUE DOUBLE DOOR  
 W/SIDELITES - IMPACT COMPONENTS

DRAWN: V.L.	DWG NO. 08-02038	REV H
SCALE NTS	DATE 04/22/13	SHEET 16 OF 16

L. ROBERTO LOMAS P.E.  
 1432 WOODFORD RD LEWISVILLE, NC 27023  
 434-688-0609 rllomas@rlomaspe.com

SIGNED: 09/08/2021



Luis R. Lomas P.E.  
 FL No.: 62514