

HORIZONTAL SLIDER - LARGE MISSILE IMPACT

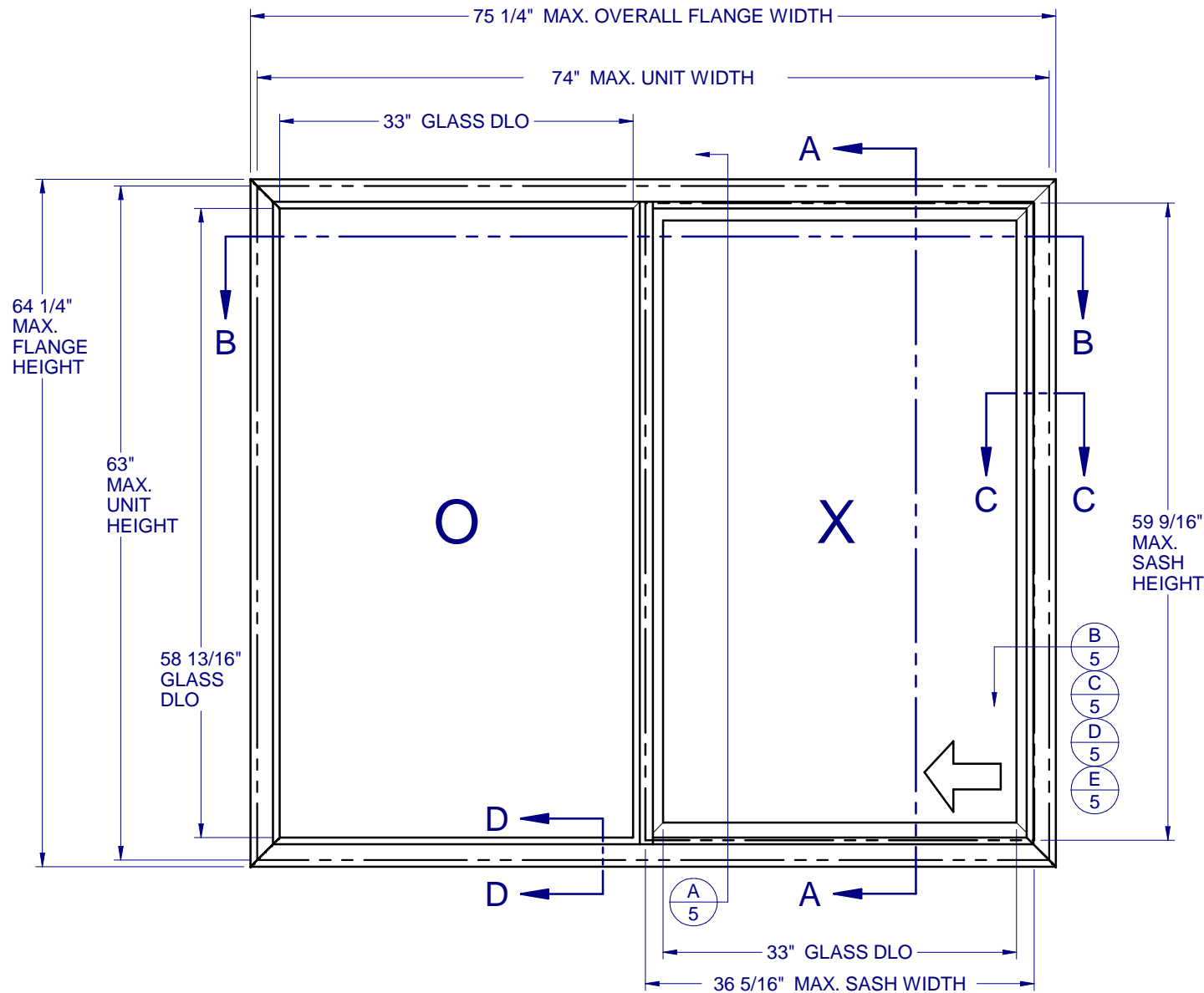

GENERAL NOTES:

1. THE PRODUCT SHOWN HEREIN IS DESIGNED AND MANUFACTURED TO COMPLY WITH THE FLORIDA BUILDING CODE (FBC), CURRENT EDITION AND IS RATED FOR WIND ZONE 3 MISSILE LEVEL D IMPACT USE AS DEFINED IN ASTM E 1996 PER THE FBC.

THIS PRODUCT MAY NOT BE USED IN THE HIGH VELOCITY HURRICANE ZONE (HVHZ) OR IN ASTM E 1996 WIND ZONE 4 AREAS.
2. GLAZING OPTIONS: (SEE SHEET 2)
3. CONFIGURATIONS: "OX", "XO".
4. DESIGN PRESSURE RATING:
-NEGATIVE DESIGN LOADS BASED ON, TESTED PRESSURE AND GLASS TABLES ASTM E-1300-04e01/09.
-POSITIVE DESIGN LOADS BASED ON, TESTED PRESSURE, WATER INFILTRATION TEST PRESSURE AND GLASS TABLES ASTM E-1300-04e01/09.
5. ANCHORAGE: THE 33 1/3% STRESS INCREASE HAS NOT BEEN USED IN THE DESIGN OF THIS PRODUCT. SEE SHEET 5 FOR ANCHOR DETAILS. WINDLOAD DURATION FACTOR Cd=1.6 WAS USED FOR WOOD ANCHOR CALCULATIONS.
6. PRODUCT APPROVED FOR IMPACT RESISTANCE. SHUTTERS ARE NOT REQUIRED. THE IMPACT ROTARY LOCKS ARE INTENDED TO BE LEFT UNLATCHED DURING NORMAL OPERATION OF THIS PRODUCT, BUT MUST BE ENGAGED PRIOR TO EXPOSURE TO HURRICANE WINDS AND FLYING DEBRIS.
7. ALL FRAMES AND VENTS FULLY WELDED. SMALL JOINT SEAM SEALANT USED AT FIXED MEETING RAIL AND HEAD/SILL.
8. SERIES / MODEL DESIGNATION HS-8200.
9. THE DESIGNATION X AND O STAND FOR THE FOLLOWING:
X = OPERABLE SASH, O = FIXED SASH
10. SECTION CALLOUTS APPLY TO ALL ELEVATIONS IN A SIMILAR LOCATION.
11. EXTERNAL WEEP SLOT = 1/4" x 1" LOCATED 4" FROM BOTH ENDS.



8200 PVC HORZ. SLIDER IMPACT

PROPRIETARY AND CONFIDENTIAL
THE INFORMATION CONTAINED IN THIS DRAWING IS THE SOLE PROPERTY OF CUSTOM WINDOW SYSTEMS, INC. ANY REPRODUCTION IN PART OR AS A WHOLE WITHOUT THE WRITTEN PERMISSION OF CUSTOM WINDOW SYSTEMS, INC IS PROHIBITED.

FLORIDA APPROVAL NO.:
16735



7/27/2023

LUCAS A. TURNER, P.E.
FL PE # 58201
Turner Engineering & Consulting, Inc.
2428 Old Natchez Trc Trl
Camden, TN 38320
PH. 941-380-1574

SHEET DESCRIPTION:
GENERAL NOTES AND ELEVATIONS

DRAWN BY: MCS	DATE: 7/26/2023
DWG #: CWS-867	REV.: E
SCALE: 1:15	SHEET 1 OF 5

TABLE OF CONTENTS

GENERAL NOTES & ELEVATIONS.....	1
SECTION VIEWS & GLAZING DETAILS....	2
BOM & EXTRUSIONS.....	3
ANCHOR SCHEDULE & NOTES.....	4
INSTALLATION DETAILS.....	5

MAX. UNIT SIZE	DESIGN PRESSURE RATING	IMPACT RATING
74" x 63"	+/- 50 PSF	LARGE MISSILE IMPACT

**8200 PVC
HORZ. SLIDER
IMPACT**

PROPRIETARY AND CONFIDENTIAL
THE INFORMATION CONTAINED IN THIS DRAWING IS THE SOLE PROPERTY OF CUSTOM WINDOW SYSTEMS, INC. ANY REPRODUCTION IN PART OR AS A WHOLE WITHOUT THE WRITTEN PERMISSION OF CUSTOM WINDOW SYSTEMS, INC IS PROHIBITED.

FLORIDA APPROVAL NO.:

16735



7/27/2023

LUCAS A. TURNER, P.E.
FL PE # 58201
Turner Engineering & Consulting, Inc.
2428 Old Natchez Trc Trl
Camden, TN 38320
PH. 941-380-1574

SHEET DESCRIPTION:

**SECTION VIEWS
AND GLAZING DETAIL**

DRAWN BY:	DATE:
MCS	7/26/2023
DWG #:	REV.:
CWS-867	E
SCALE:	SHEET
1:2	2 OF 5

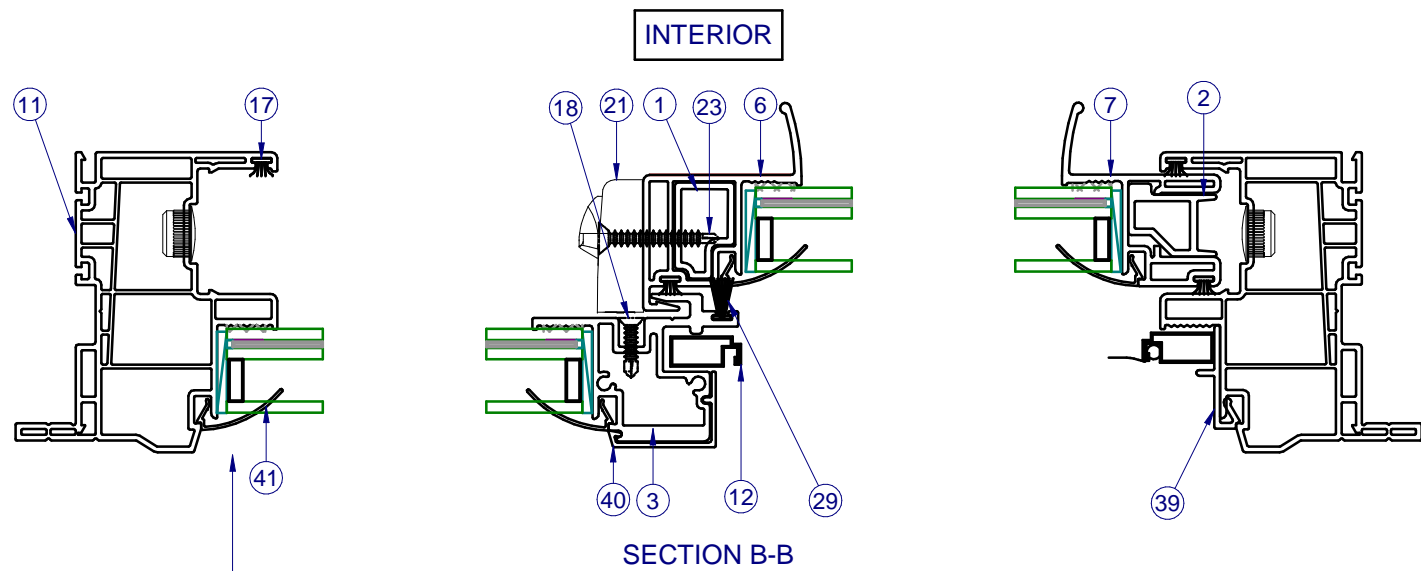

NOTE: FIXED LITE AT HEAD AND SILL IS SIMILAR.

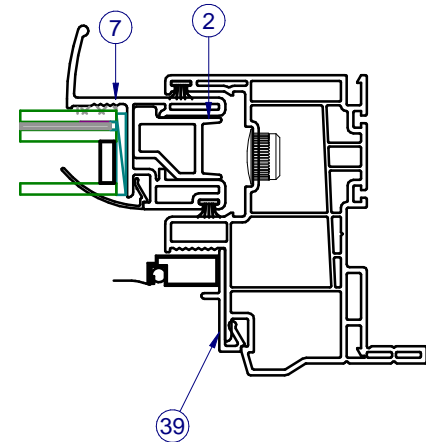

SECTION VIEW C-C
ALTERNATE JAMB ROTARY LOCKS
MAY BE SUBSTITUTED FOR JAMB IMPACT HOOKS

NOTE: ROTARY LOCKS ARE TO BE ENGAGED ONLY DURING HURRICANE CONDITIONS.

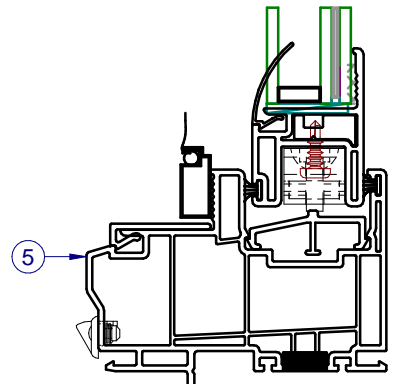
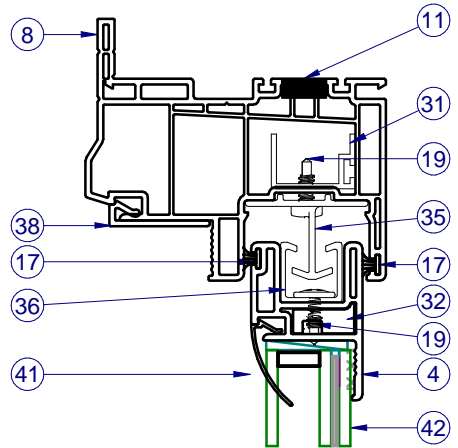
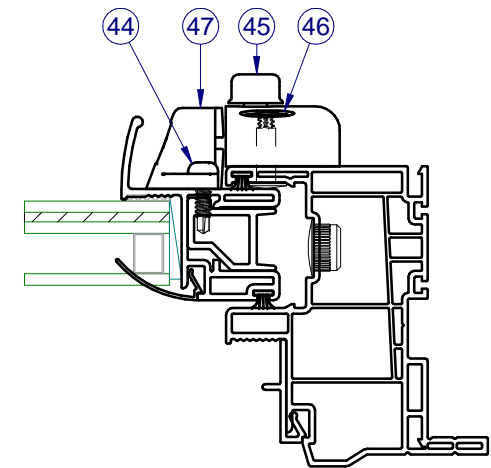

SECTION D-D
ALTERNATE FIN ONLY FRAME

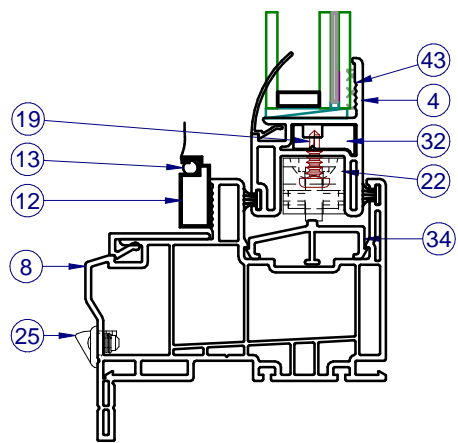

SECTION A-A

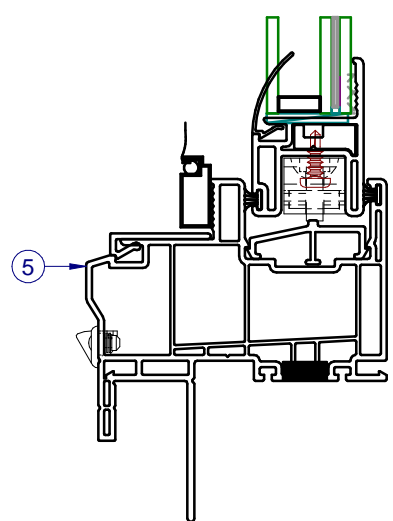

SECTION D-D
ALTERNATE FIN FRAME

HEAD IMPACT HOOK (TYP.)
MIDSPAN OF SASH
(ITEMS 35 & 36)

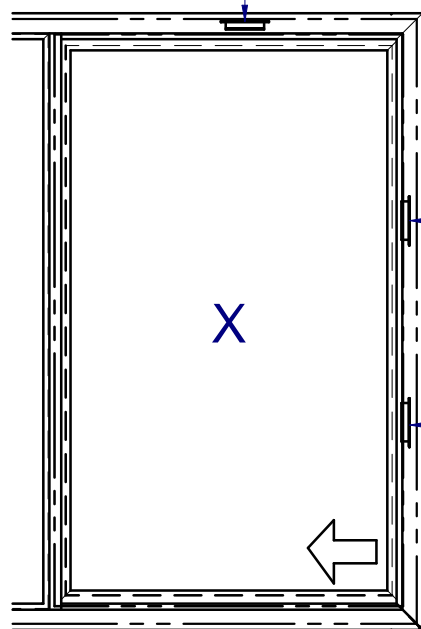

HEAD IMPACT HOOK AND
JAMB IMPACT HOOK/ROTARY LOCK LOCATIONS
1:20

FIN FRAME ONLY:
JAMB IMPACT HOOKS
OR ROTARY LOCKS
LOCATED AT THIRD POINTS

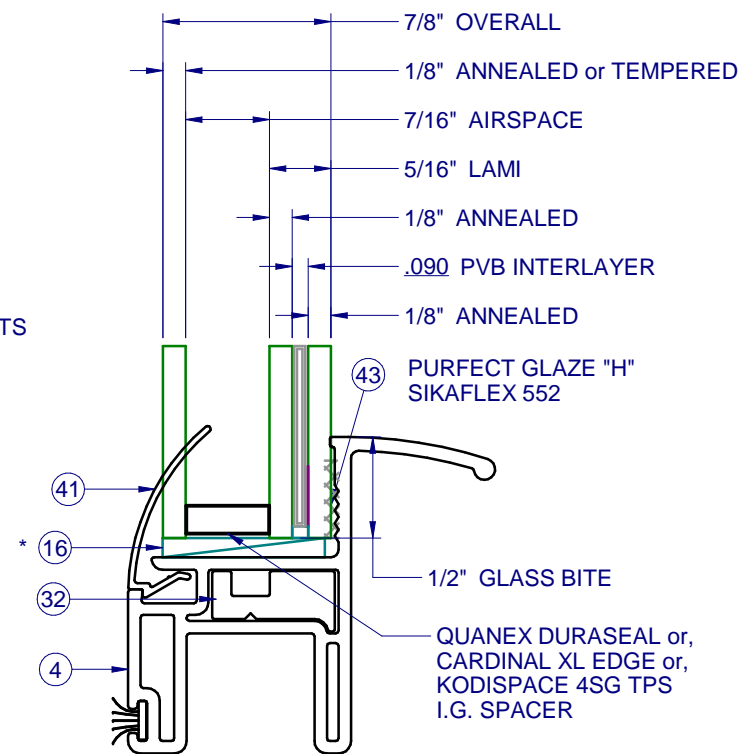

GLASS TYPE A
1:1

PARTS LIST			
ITEM	PART #	DESCRIPTION	MATERIAL
1	H-2124	Reinf. Sash Meet. Rail	Alum
2	H-2123	Reinf. S.B.R./S.S.R,	Alum
3	H-2121	Meet. Rail, Fxd.	Alum
4	H-6225	Sash, Rail/Stile	PVC
5	H-6231	Main Fr., SH, w/ Fin., PVC	PVC
6	H-6224	Sash Meet. Rail, PVC	PVC
7	H-6223	Sash, Pull Rail/Stile, PVC	PVC
8	H-6222	Main Fr., SH, w/Flg., PVC	PVC
9	P-3029	Screen Pull Tab	
10	P-3195	SPRING, NO HOLE TENSION C-8400	
12	P-3218	Screen Frame	RollForm
13	P-5576	Screen Spline, .125" Black PE Ribbed	
14	P-4754	SCREEN CORNER KEY (Rollform Scrm	Nylon
15	P-3342	Seam Sealer, SM-5504	Silicone
16	P-5612	Set. Block, .12x1x2	Rubber
17	P-3429	Wstp., 0.270 x .187 back FinSeal, Gray	
18	P-3541	#8 x 1/2" SQUARE TEK 2 Zinc	Steel
19	P-4730	#8 x 1/2" Truss PH TEK 2 Zinc	Steel
20	P-5588	Cap Plug, 1/2" Hole	Nylon
21	P-3783	Lock, Impact, PVC	
22	P-5241	Roller Ass., Tandem, w/SS Bearings	Nylon
23	P-4051	#8 x 1 1/4 Ph FH TEK, Wht.	Steel
24	P-4069	Keeper, Impact, PVC	
25	P-4479	Weep Cover w/ Flap	Nylon
26	P-4638	#8 x 2 1/2 Ph Truss SMS	Steel
29	P-4959	Wstp., 0.420 x .187 back FinSeal, Gray	
31	S-1112	Reinforcement	Alum
32	S-2129	Reinf. S.B.R./S.S.R,	Alum
33	S-1577	Frame Hook, PVC Impact	Alum
34	S-1776	Roller Track	Alum
35	S-1999	Frame Hook, Head, Impact	Alum
36	S-2000	Panel Catch, Head, Impact	Alum
38	S-6226	Scrn. Adapt., w/ Nib, PVC	PVC
39	S-6227	Scrn. Adapt., PVC	PVC
40	S-6228	Fixed Rail Cover	PVC
41	S-6237	Glazing Bead	PVC
42	GLASS	SEE SHEET 2	GLASS
43		Purfect Glaze "H", SikaFlex 552	Silicone
44	P-3539	#8 x 3/4" Square PH Tek, Wht.	Steel
45	P-4958	Rotary Lock	
46	P-4633	8-32 x 1/2" Barrel Fastener	
47	P-4952	Keeper, Rotary Lock	

LINE ITEMS NOT USED:
11, 27-28, 30

NOTE: ALL EXTRUSIONS ARE ALUMINUM 6063-T6 UNLESS OTHERWISE NOTED.

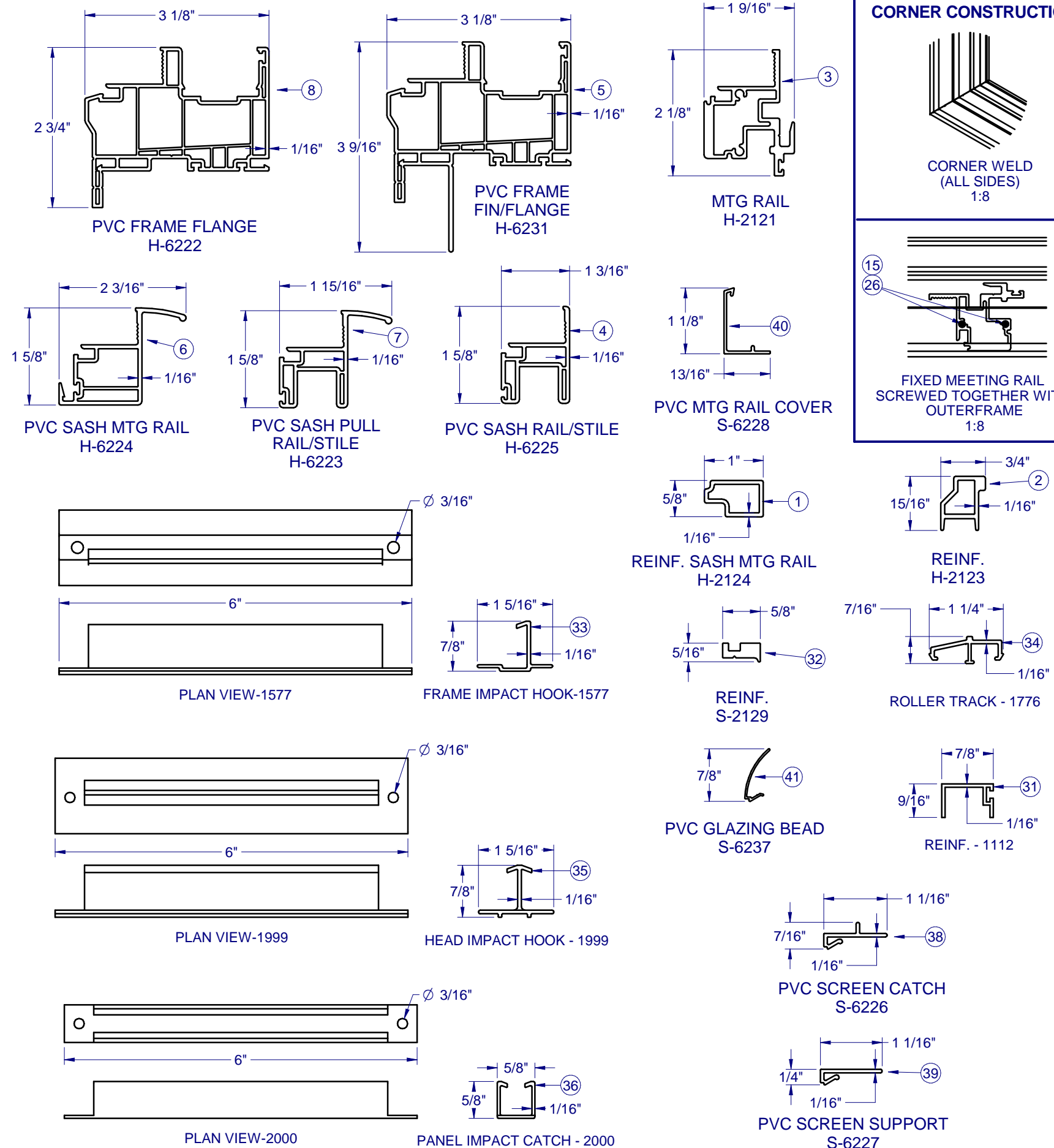

1900 SW 44TH AVE.
OCALA, FLORIDA 34474
WWW.CWS.CC

**8200 PVC
HORZ. SLIDER
IMPACT**

PROPRIETARY AND CONFIDENTIAL

THE INFORMATION CONTAINED IN THIS DRAWING IS THE SOLE PROPERTY OF CUSTOM WINDOW SYSTEMS, INC. ANY REPRODUCTION IN PART OR AS A WHOLE WITHOUT THE WRITTEN PERMISSION OF CUSTOM WINDOW SYSTEMS, INC IS PROHIBITED.

FLORIDA APPROVAL NO.:
16735

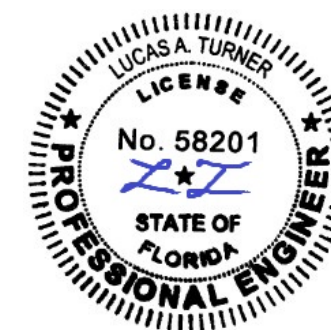

7/27/2023

LUCAS A. TURNER, P.E.
FL PE # 58201
Turner Engineering & Consulting, Inc.
2428 Old Natchez Trc Trl
Camden, TN 38320
PH. 941-380-1574

SHEET DESCRIPTION:
BOM AND EXTRUSIONS

DRAWN BY: MCS	DATE: 7/26/2023
DWG #: CWS-867	REV.: E
SCALE: 1:2	SHEET 3 OF 5

**8200 PVC
HORZ. SLIDER
IMPACT**

PROPRIETARY AND CONFIDENTIAL
THE INFORMATION CONTAINED IN
THIS DRAWING IS THE SOLE
PROPERTY OF CUSTOM WINDOW
SYSTEMS, INC. ANY
REPRODUCTION IN PART OR AS A
WHOLE WITHOUT THE WRITTEN
PERMISSION OF CUSTOM WINDOW
SYSTEMS, INC IS PROHIBITED.

FLORIDA APPROVAL NO.:

16735

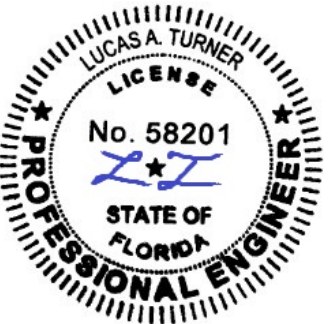

7/27/2023

LUCAS A. TURNER, P.E.
FL PE # 58201
Turner Engineering &
Consulting, Inc.
2428 Old Natchez Trc Trl
Camden, TN 38320
PH. 941-380-1574

SHEET DESCRIPTION:

**ANCHOR SCHEDULE AND
NOTES**

DRAWN BY:	DATE:
MCS	7/26/2023
DWG #:	REV.:
CWS-867	E
SCALE:	SHEET
1:20	4 OF 5

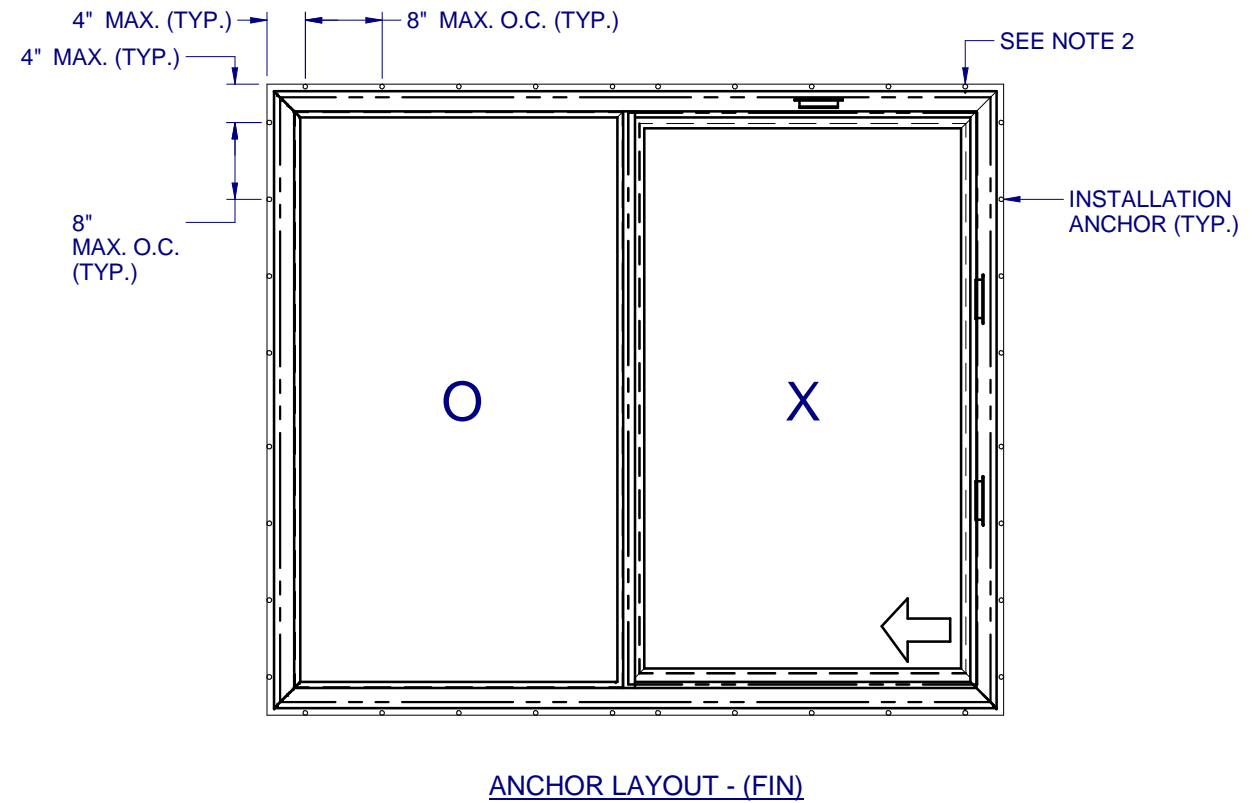
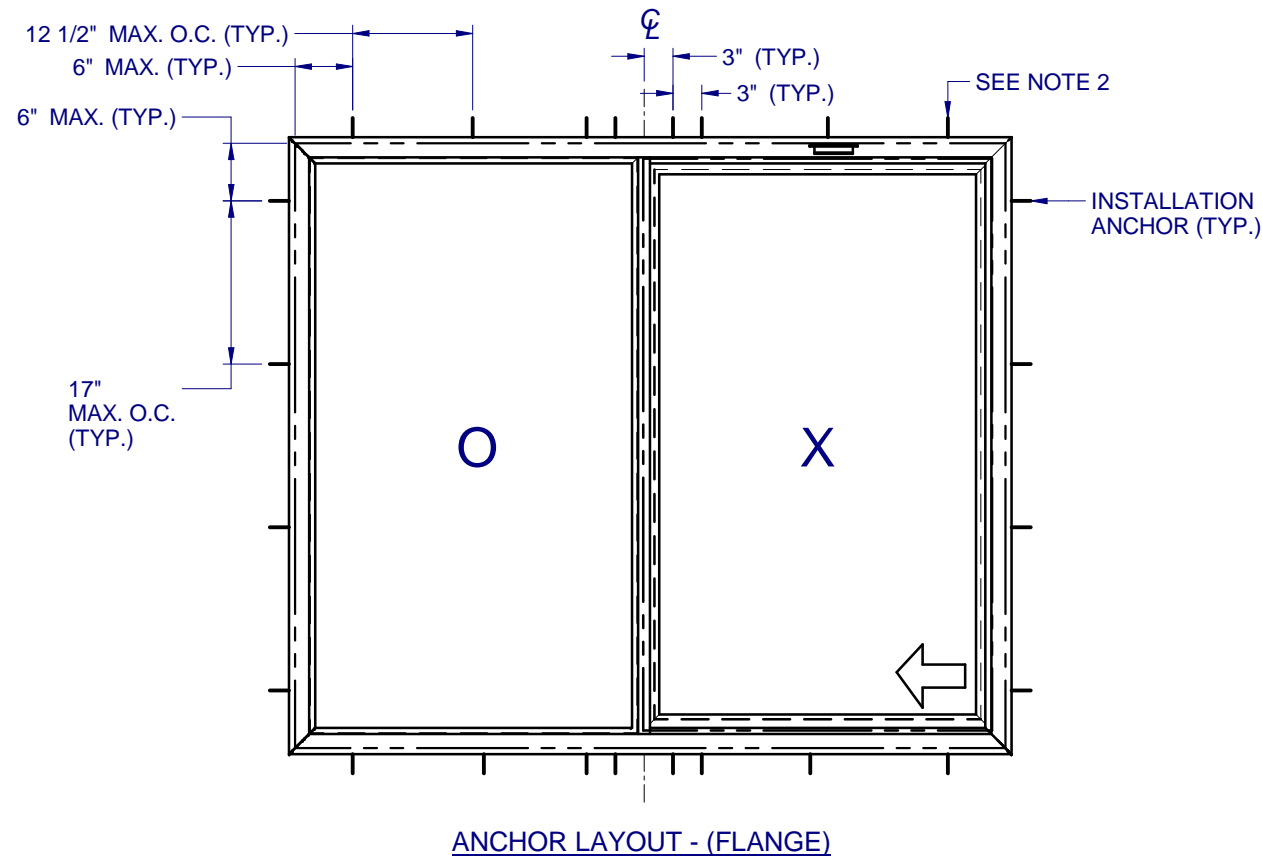

NOTES:

1. INSTALL ONE ANCHOR AT EACH INSTALLATION LOCATION. SILL ANCHOR SPACING SAME AS HEAD.
2. SHIM AS REQ AT EACH INSTALLATION ANCHOR USING LOAD BEARING SHIMS. MAX. ALLOWABLE SHIM STACK TO BE 1/4". USE SHIMS WHERE SPACE GREATER THAN 1/16" IS PRESENT. LOAD BEARING SHIMS SHALL BE CONSTRUCTED OF HIGH DENSITY PLASTIC OR BETTER. WOOD SHIMS ARE NOT ALLOWED.
3. ANCHOR TYPE, SIZE, SPACING AND EMBEDMENT SHALL BE AS SPECIFIED IN THESE DRAWINGS, SEE TABLE 1, SHEET 5.
4. ALL INSTALLATION ANCHORS MUST BE MADE OF OR PROTECTED WITH A CORROSION RESISTANT MATERIAL OR COATING. DISSIMILAR METALS OR MATERIALS IN CONTACT WITH PRESSURE TREATED WOOD MUST BE PROTECTED TO PREVENT REACTION.
5. INSTALLATION ANCHORS SHALL BE IN ACCORDANCE WITH ANCHOR MANUFACTURER'S INSTALLATION INSTRUCTIONS, AND ANCHORS SHALL NOT BE USED IN SUBSTRATES WITH STRENGTHS LESS THAN THE MINIMUM SPECIFIED IN TABLE 1, SHEET 5.
6. ANCHOR EMBEDMENT TO SUBSTRATE SHALL BE BEYOND WALL DRESSING OR STUCCO. FOR CONCRETE/CMU OPENINGS, EMBEDMENT SHALL BE BEYOND WOOD BUCKS, IF USED, INTO SUBSTRATE. INSTALLATIONS TO SOLID CONCRETE OR GROUT-FILLED CMU MAY INCLUDE BUT DO NOT REQUIRE 1X WOOD BUCKS BETWEEN THE PRODUCT AND SUBSTRATE. INSTALLATIONS TO HOLLOW CMU REQUIRE THE USE OF 1X BUCKS BETWEEN THE PRODUCT AND SUBSTRATE.
7. A MINIMUM CENTER-TO-CENTER SPACING SHALL BE MAINTAINED BETWEEN ALL FASTENERS: 3" FOR MASONRY, 1" FOR WOOD AND METAL.
8. WOOD OR MASONRY OPENINGS, BUCKS AND BUCK FASTENERS SHALL BE PROPERLY DESIGNED BY THE ARCHITECT OR ENGINEER OF RECORD AND INSTALLED TO TRANSFER WIND LOADS TO THE STRUCTURE. SUBSTRATES SHALL MEET THE MINIMUM STRENGTH REQUIREMENTS AS SHOWN IN TABLE 1, SHEET 5. CONCRETE AND MASONRY SUBSTRATES MAY NOT BE CRACKED.
9. SEALING AND FLASHING STRATEGIES FOR OVERALL WATER RESISTANCE OF INSTALLATION SHALL BE DONE BY OTHERS FOLLOWING THE CURRENT VERSION OF THE REFERENCE DOCUMENTS: FMA/AAMA 100(FIN WINDOWS), FMA/AAMA 200(FLANGE WINDOWS), FMA/WDMA 250(BOX WINDOWS), FMA/AAMA/WDMA 300(EXTERIOR DOORS)

8200 PVC HORZ. SLIDER IMPACT

PROPRIETARY AND CONFIDENTIAL
THE INFORMATION CONTAINED IN THIS DRAWING IS THE SOLE PROPERTY OF CUSTOM WINDOW SYSTEMS, INC. ANY REPRODUCTION IN PART OR AS A WHOLE WITHOUT THE WRITTEN PERMISSION OF CUSTOM WINDOW SYSTEMS, INC IS PROHIBITED.

FLORIDA APPROVAL NO.:
16735



7/27/2023

LUCAS A. TURNER, P.E.
FL PE # 58201
Turner Engineering & Consulting, Inc.
2428 Old Natchez Trc Trl
Camden, TN 38320
PH. 941-380-1574

SHEET DESCRIPTION:

INSTALLATION DETAILS

DRAWN BY:	DATE:
MCS	7/26/2023
DWG #:	REV.:
CWS-867	E
SCALE:	SHEET
1:2	5 OF 5

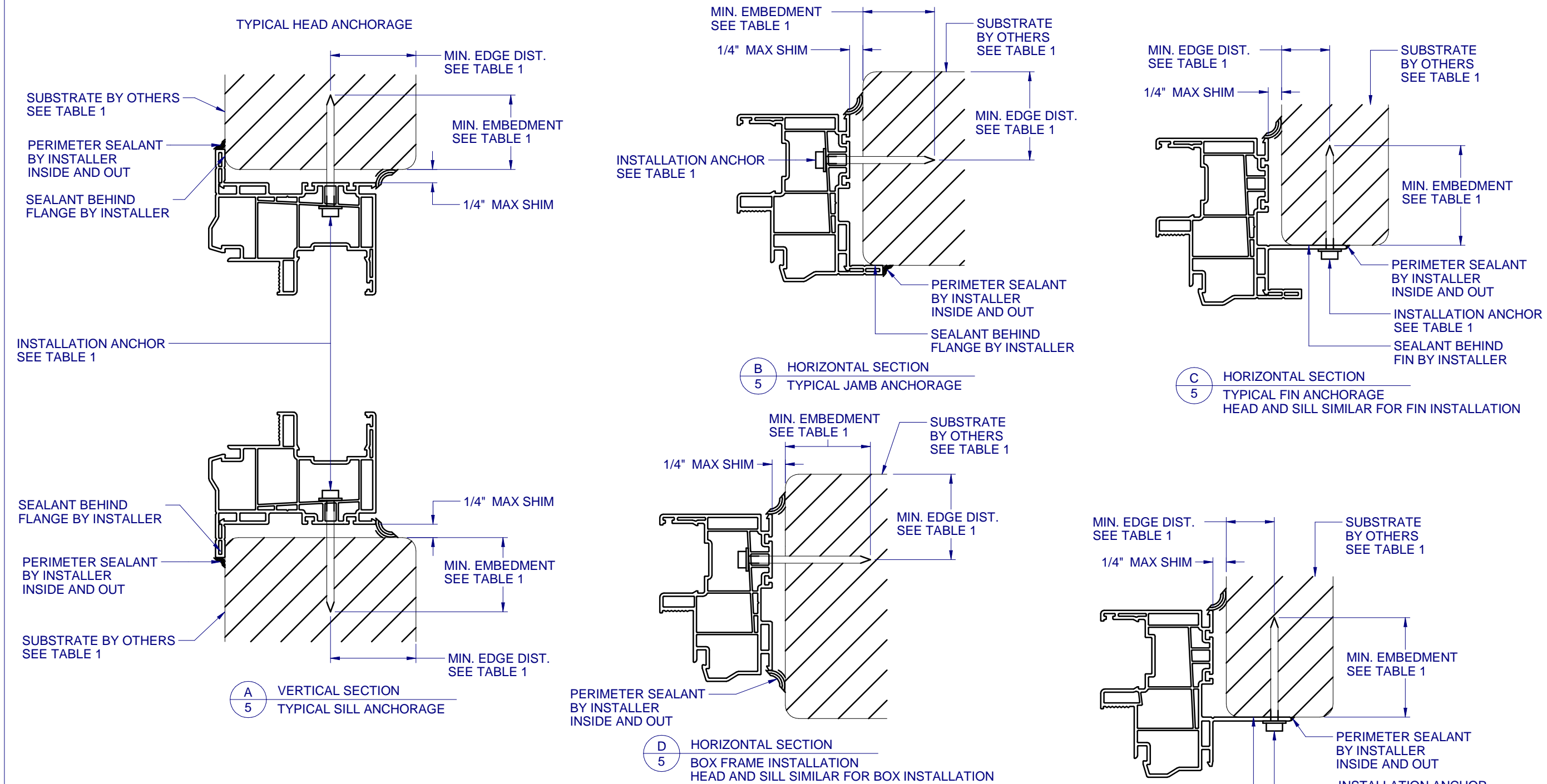

FRAME TYPE	SUBSTRATE TYPE	ANCHOR TYPE	MIN. EMBEDMENT	MIN. EDGE DIST.
FLANGE	CONCRETE (2.0 KSI MIN.)	3/16" ITW TAPCON	1-1/2"	1-1/8"
FLANGE	HOLLOW OR GROUT-FILLED CMU (117 PCF MIN.)	3/16" ITW TAPCON	1"	2"
FLANGE	CONCRETE (3.05 KSI MIN.)	3/16" DEWALT ULTRACON+	1-3/4"	1"
FLANGE	HOLLOW OR GROUT-FILLED CMU (ASTM C-90)	3/16" DEWALT ULTRACON+	1-1/4"	2-1/2"
FLANGE	2X MIN. SOUTHERN PINE (G=0.55)	3/16" ITW TAPCON OR DEWALT ULTRACON+	1-3/8"	7/8"
FLANGE	2X MIN. SOUTHERN PINE (G=0.55)	#10 WOOD SCREW	1-3/8"	7/8"
FLANGE	16 GAUGE (0.060") MIN. STEEL STUD (33 KSI YIELD MIN)	#10-16 HILTI KWIK-FLEX OR ITW TEKS SELF-DRILLING SCREW	FULL THREAD THRU 0.060"	7/16"
FLANGE	1/8" ALUM. (6063-T5 MIN.) OR 1/8" STEEL (33 KSI MIN.)	#10 GRADE 5 SELF-TAPPING / DRILLING SCREW	FULL THREAD THRU 0.125"	7/16"
FIN	2X MIN. SOUTHERN PINE (G=0.55)	#8 WOOD SCREW	1-1/2"	1/2"

FLANGE REMOVAL NOTE: PARTIALLY OR FULLY REMOVING THE FLANGE, UP TO AND INCLUDING A BOX-FRAME APPLICATION IS ACCEPTABLE PROVIDED:

- MIN. 1/4" FILLET OF CONSTRUCTION-GRADE ADHESIVE CAULK IS APPLIED INSIDE AND OUT, FULL PERIMETER, BY INSTALLER.
- PRODUCT ANCHORAGE IS IN ACCORDANCE WITH REQUIREMENTS AS SHOWN FOR FLANGE WINDOWS.