

PICTURE WINDOW - LARGE MISSILE IMPACT

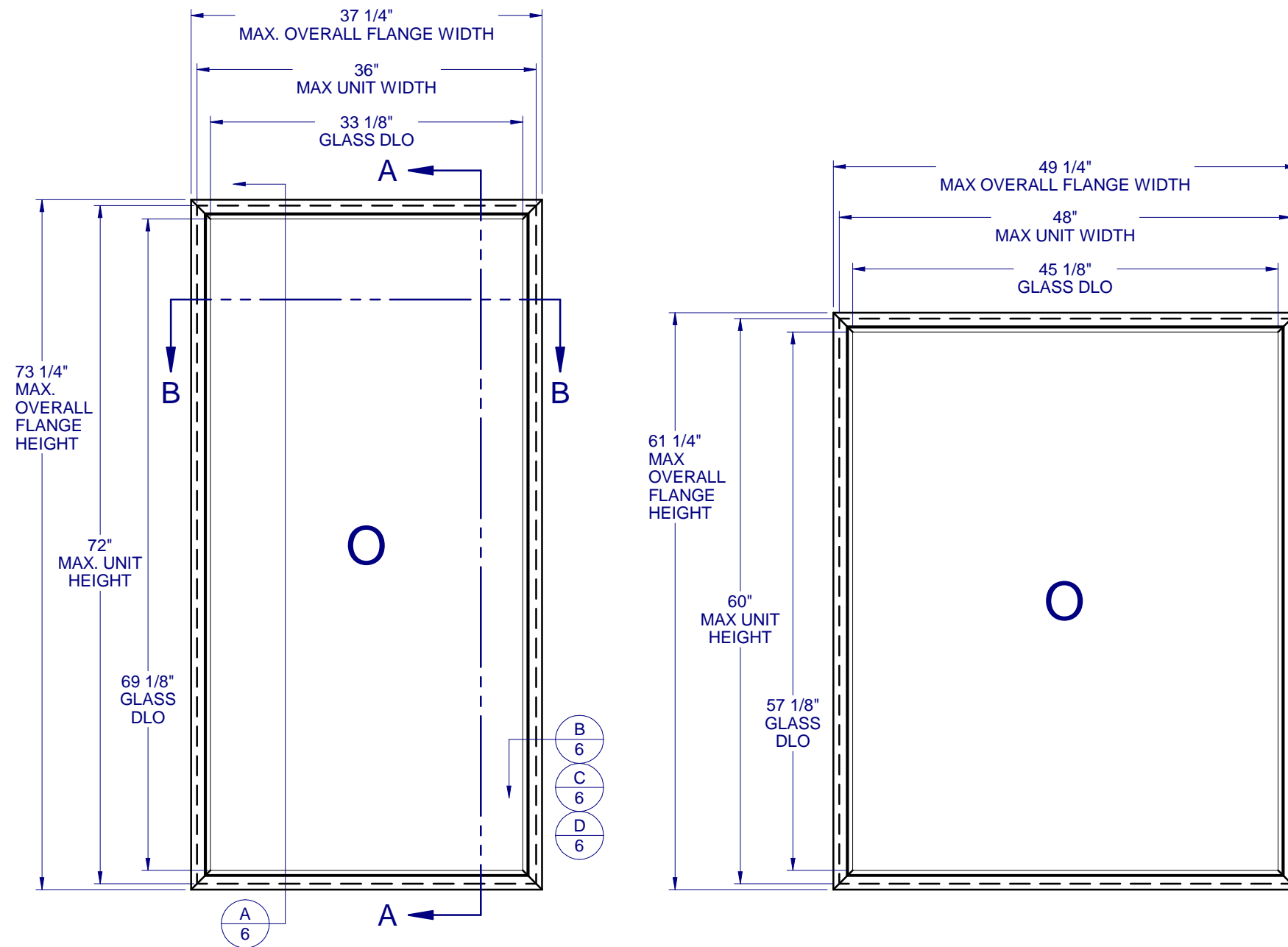

GENERAL NOTES:

1. THE PRODUCT SHOWN HEREIN IS DESIGNED AND MANUFACTURED TO COMPLY WITH THE FLORIDA BUILDING CODE (FBC), CURRENT EDITION AND IS RATED FOR WIND ZONE 3 MISSILE LEVEL D IMPACT USE AS DEFINED IN ASTM E 1996 PER THE FBC.

THIS PRODUCT MAY NOT BE USED IN THE HIGH VELOCITY HURRICANE ZONE (HVHZ) OR IN ASTM E 1996 WIND ZONE 4 AREAS.

2. GLAZING OPTIONS: (SEE SHEET 3)

3. CONFIGURATIONS: "O". ARCHITECTURAL SHAPES INCLUDE, BUT ARE NOT LIMITED TO, THOSE SHOWN ON SHEET 2.

4. DESIGN PRESSURE RATING:
 -NEGATIVE DESIGN LOADS BASED ON, TESTED PRESSURE AND GLASS TABLES ASTM E-1300-04e01/09.
 -POSITIVE DESIGN LOADS BASED ON, TESTED PRESSURE, WATER INFILTRATION TEST PRESSURE AND GLASS TABLES ASTM E-1300-04e01/09.

5. ANCHORAGE: THE 33 1/3% STRESS INCREASE HAS NOT BEEN USED IN THE DESIGN OF THIS PRODUCT. SEE SHEET 6 FOR ANCHOR DETAILS. WINDLOAD DURATION FACTOR Cd=1.6 WAS USED FOR WOOD ANCHOR CALCULATIONS.

6. PRODUCT APPROVED FOR IMPACT RESISTANCE. SHUTTERS ARE NOT REQUIRED.

7. ALL FRAMES ARE FULLY WELDED.

8. SERIES / MODEL DESIGNATION PW-8300.

9. THE DESIGNATION X AND O STAND FOR THE FOLLOWING:
 O = FIXED SASH.

10. SECTION CALLOUTS APPLY TO ALL ELEVATIONS IN A SIMILAR LOCATION.



1900 SW 44TH AVE.
 OCALA, FLORIDA 34474
 WWW.CWS.CC

8300 PVC PICTURE WINDOW IMPACT

PROPRIETARY AND CONFIDENTIAL
 THE INFORMATION CONTAINED IN THIS DRAWING IS THE SOLE PROPERTY OF CUSTOM WINDOW SYSTEMS, INC. ANY REPRODUCTION IN PART OR AS A WHOLE WITHOUT THE WRITTEN PERMISSION OF CUSTOM WINDOW SYSTEMS, INC IS PROHIBITED.

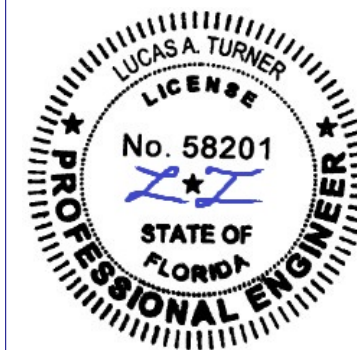

8/05/2020

LUCAS A. TURNER, P.E.
 FL PE # 58201
 2428 Old Natchez Trc Trl
 Camden, TN 38320
 PH. 941-380-1574

SHEET DESCRIPTION:

GENERAL NOTES AND ELEVATIONS

DRAWN BY: EMK	DATE: 10/07/14
DWG #: CWS-1033	REV.: C
SCALE: 1:1	SHEET 1 OF 6

TABLE OF CONTENTS

GENERAL NOTES & ELEVATIONS.....1
 ARCHITECTURAL SHAPES.....2
 SECTION VIEWS & GLAZING.....3
 EXTRUSIONS & B.O.M.....4
 ANCHOR SCHEDULE & NOTES.....5
 INSTALLATION DETAILS.....6

MAX. UNIT SIZE	DESIGN PRESSURE RATING	IMPACT RATING
48" x 60"	+/- 50 PSF	LARGE MISSILE IMPACT
36" x 72"	+/- 55 PSF	

**8300 PVC
PICTURE WINDOW
IMPACT**

PROPRIETARY AND CONFIDENTIAL
THE INFORMATION CONTAINED IN
THIS DRAWING IS THE SOLE
PROPERTY OF CUSTOM WINDOW
SYSTEMS, INC. ANY
REPRODUCTION IN PART OR AS A
WHOLE WITHOUT THE WRITTEN
PERMISSION OF CUSTOM WINDOW
SYSTEMS, INC IS PROHIBITED.

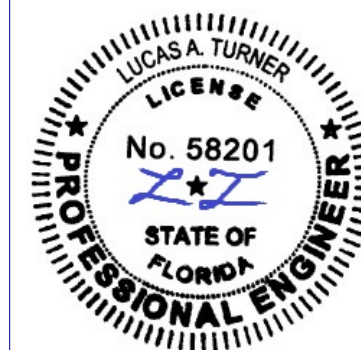

8/05/2020

LUCAS A. TURNER, P.E.
FL PE # 58201
2428 Old Natchez Trc Trl
Camden, TN 38320
PH. 941-380-1574

SHEET DESCRIPTION:

**ARCHITECTURAL
SHAPES**

DRAWN BY:	DATE:
EMK	10/07/14
DWG #:	REV.:
CWS-1033	C
SCALE:	SHEET
1:1	2 OF 6

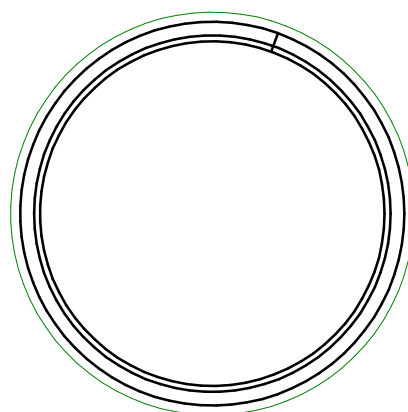

FULL CIRCLE

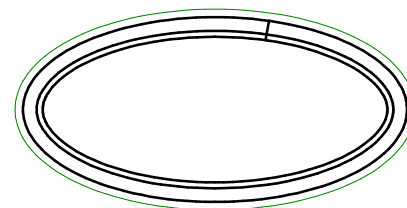

FULL ELLIPSE ("OVAL")

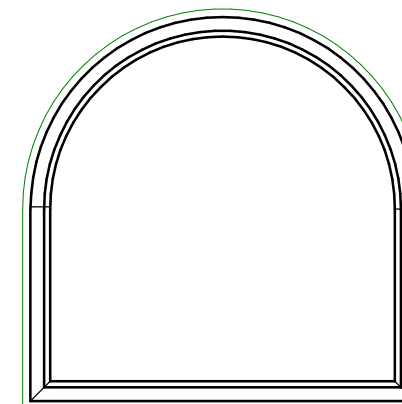

TOMBSTONE

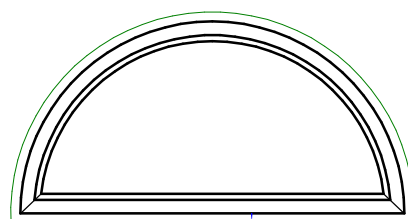

1/2 CIRCLE

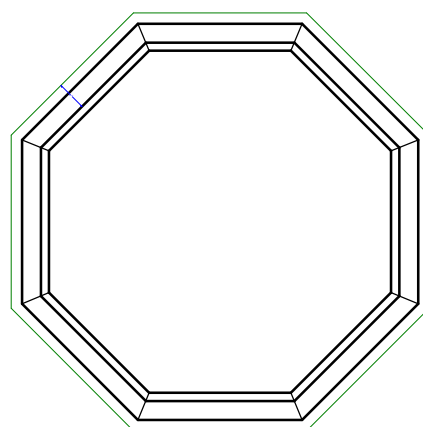

OCTAGON

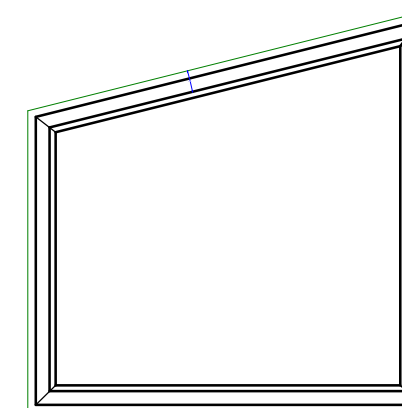

TRAPEZOID

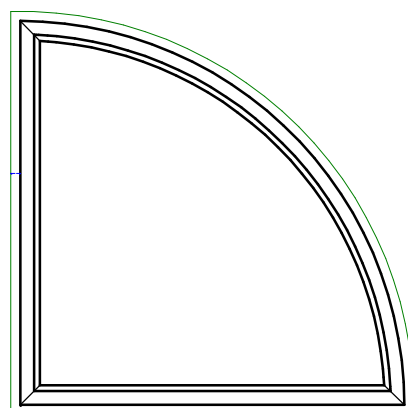

1/4 CIRCLE

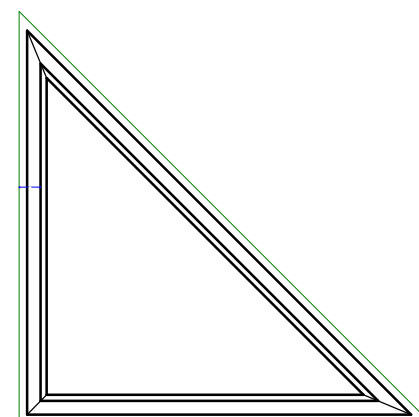

TRIANGLE

NOTES:

1. SEE SHEET 5 FOR DETAILED ANCHOR INSTALLATION REQUIREMENTS.
2. THRU FRAME - MASONRY, WOOD OR METAL OPENING.
THRU FIN - WOOD OPENING.
3. OVERALL SIZE MUST NOT EXCEED THE MAX. WIDTH AND HEIGHT OF
RECTANGULAR WINDOWS ON SHEET 1.
4. ANCHOR SPACING FOR ARCHITECTURAL FLANGE AND FIN WINDOWS
MUST FOLLOW THE LAYOUTS SHOWN ON SHEET 5, WITH ANCHOR
SPACING MEASURED ALONG THE LENGTH OF THE PRODUCT.

**8300 PVC
PICTURE WINDOW
IMPACT**

PROPRIETARY AND CONFIDENTIAL
THE INFORMATION CONTAINED IN
THIS DRAWING IS THE SOLE
PROPERTY OF CUSTOM WINDOW
SYSTEMS, INC. ANY
REPRODUCTION IN PART OR AS A
WHOLE WITHOUT THE WRITTEN
PERMISSION OF CUSTOM WINDOW
SYSTEMS, INC IS PROHIBITED.

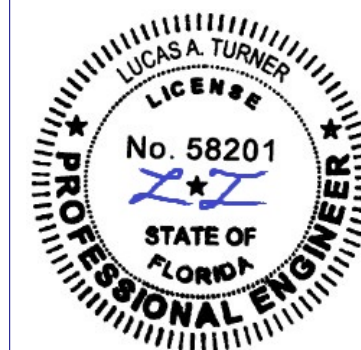

8/05/2020

LUCAS A. TURNER, P.E.
FL PE # 58201
2428 Old Natchez Trc Trl
Camden, TN 38320
PH. 941-380-1574

SHEET DESCRIPTION:

**SECTION VIEWS AND
GLAZING DETAIL**

DRAWN BY:	DATE:
EMK	10/07/14
DWG #:	REV.:
CWS-1033	C
SCALE:	SHEET
1:2	3 OF 6

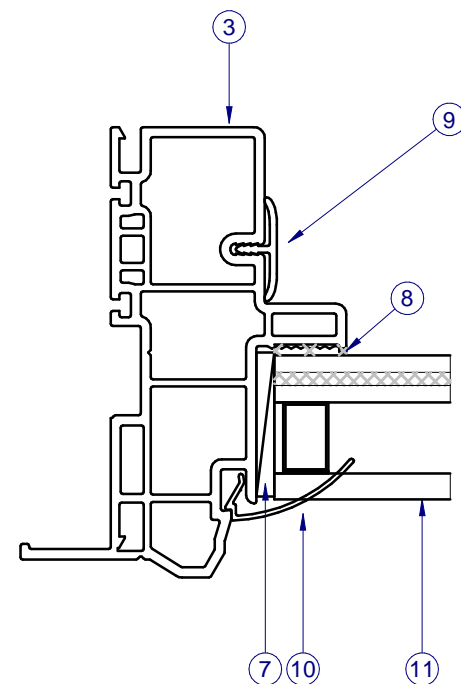

INTERIOR

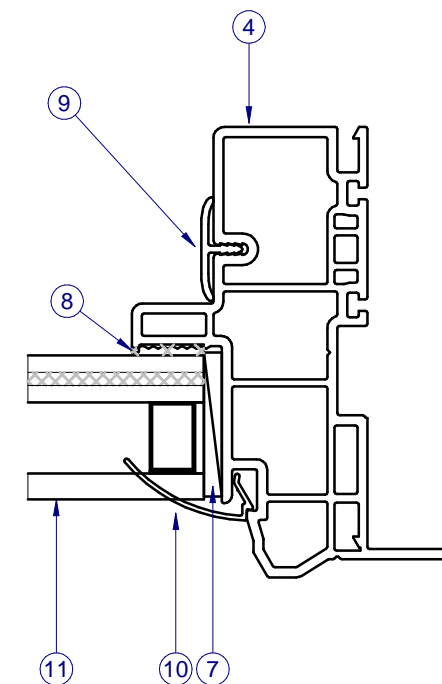

SECTION VIEW B-B

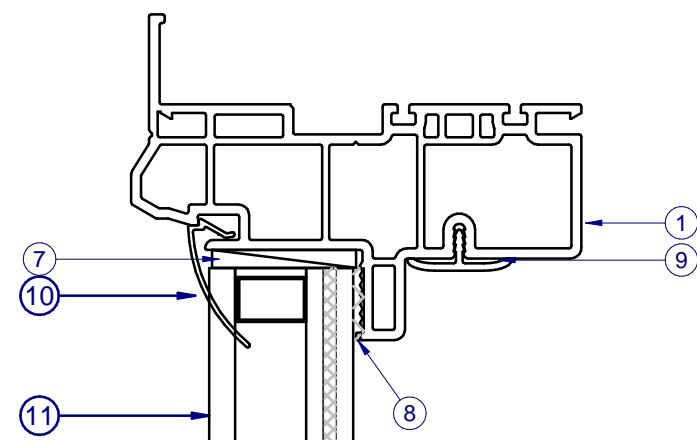

INTERIOR

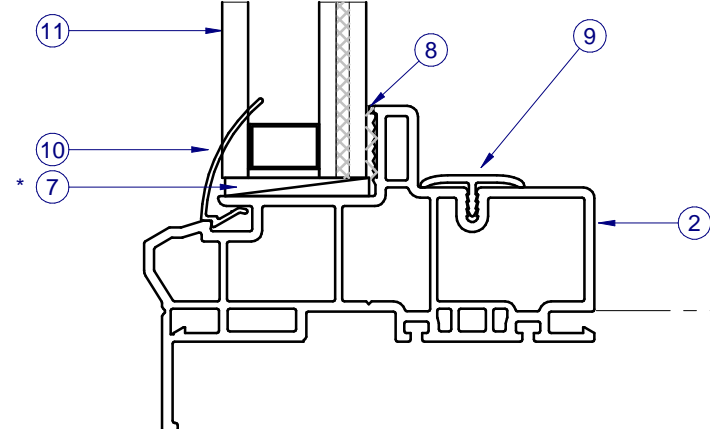

SECTION VIEW A-A

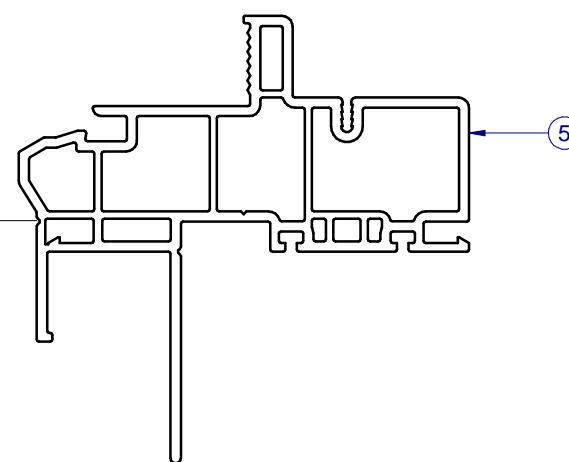

ALTERNATE FIN FRAME

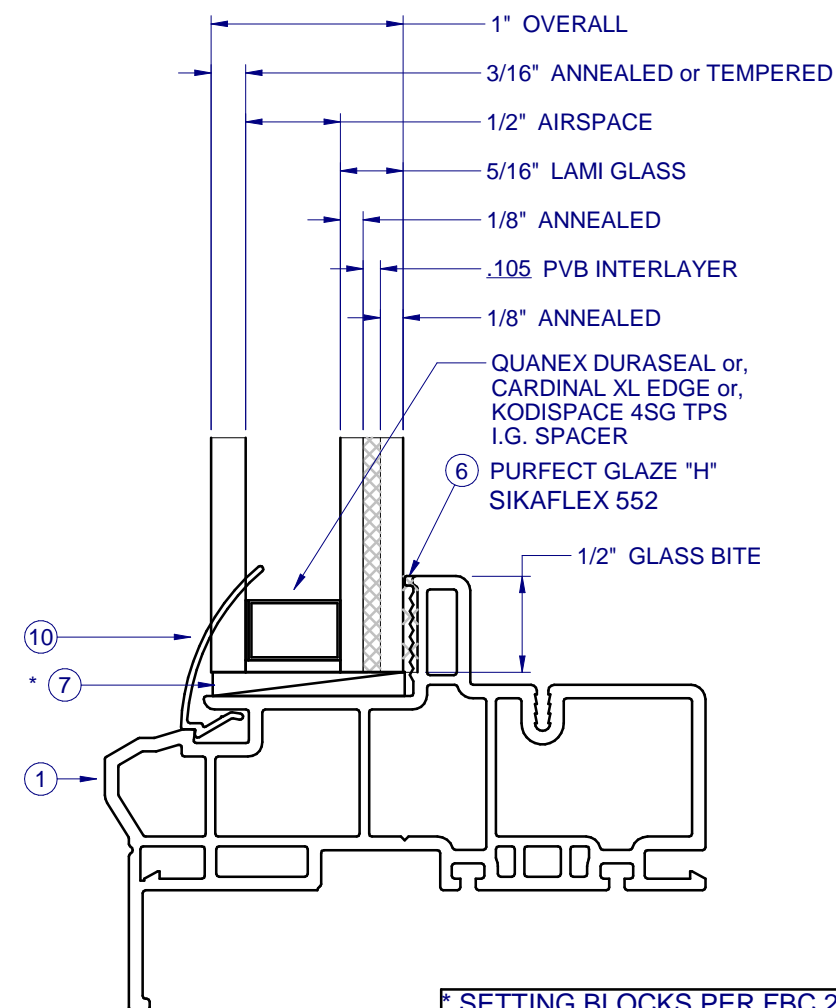

* SETTING BLOCKS PER FBC 2411.3.3.1

PARTS LIST			
ITEM	PART #	DESCRIPTION	MATERIAL
1	H-6232	FRAME, PW, MAIN, HEAD	PVC
2	H-6232	FRAME, PW, MAIN, SILL	PVC
3	H-6232	FRAME, PW, MAIN, L. JAMB	PVC
4	H-6232	FRAME, PW, MAIN, R. JAMB	PVC
5	H-6232	FRAME, PW, MAIN, FIN	PVC
7	P-5615	SET. BLK., 85 DUR., 1/8" x 1" x 2" LG.	RUBBER
8		PURFECT GLAZE "H", SIKAFLEX 552	SILICONE
9	S-6233	TRIM COVER	PVC
10	S-6237	GLZ BE., FXD.	PVC
11	GLASS	SEE SHEET 3	

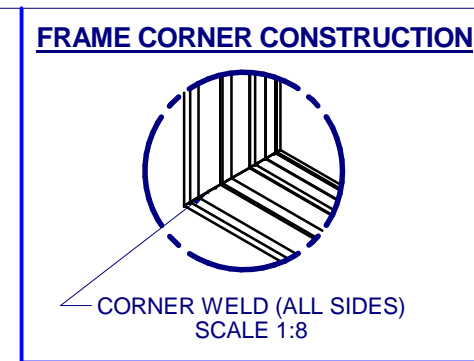

Custom
WINDOW SYSTEMS

1900 SW 44TH AVE.
OCALA, FLORIDA 34474
WWW.CWS.CC

**8300 PVC
PICTURE WINDOW
IMPACT**

PROPRIETARY AND CONFIDENTIAL

THE INFORMATION CONTAINED IN THIS DRAWING IS THE SOLE PROPERTY OF CUSTOM WINDOW SYSTEMS, INC. ANY REPRODUCTION IN PART OR AS A WHOLE WITHOUT THE WRITTEN PERMISSION OF CUSTOM WINDOW SYSTEMS, INC IS PROHIBITED.

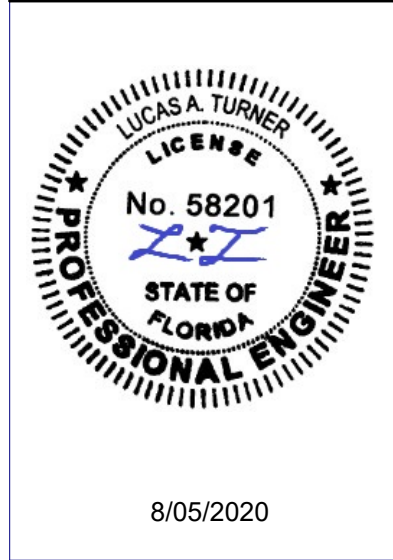

LUCAS A. TURNER, P.E.
FL PE # 58201
2428 Old Natchez Trc Trl
Camden, TN 38320
PH. 941-380-1574

SHEET DESCRIPTION:
BOM AND EXTRUSIONS

DRAWN BY:	DATE:
EMK	10/07/14
DWG #:	REV.:
CWS-1033	C
SCALE:	SHEET
1:1	4 OF 6

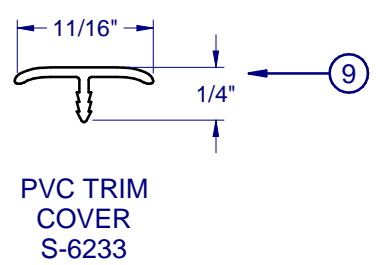
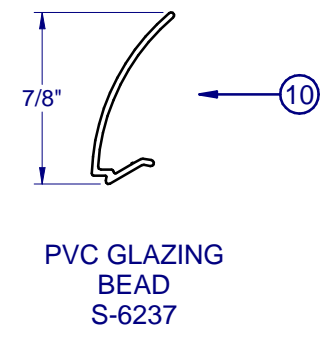
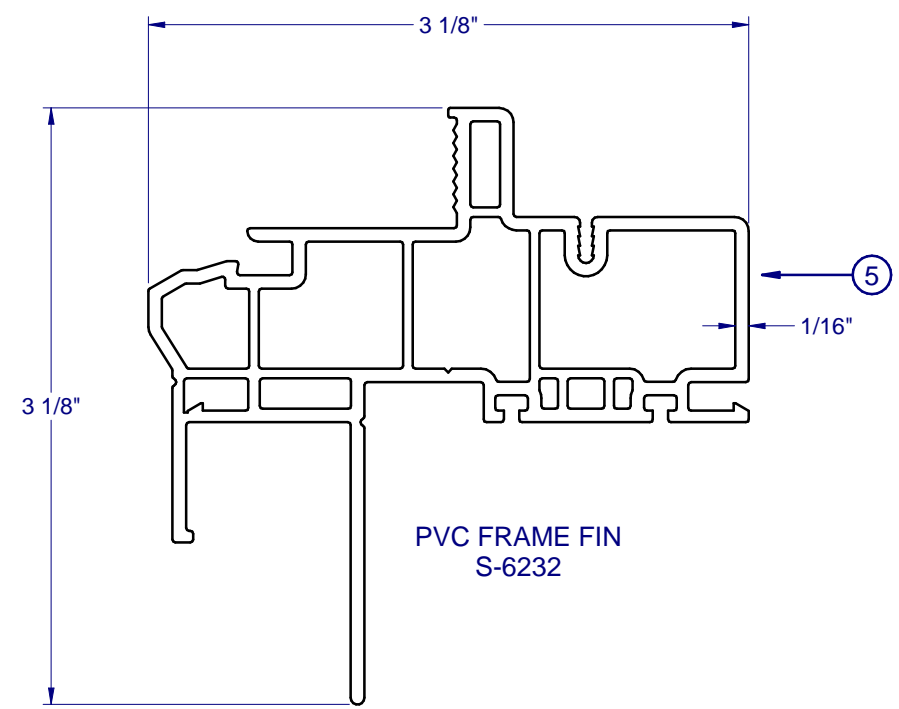
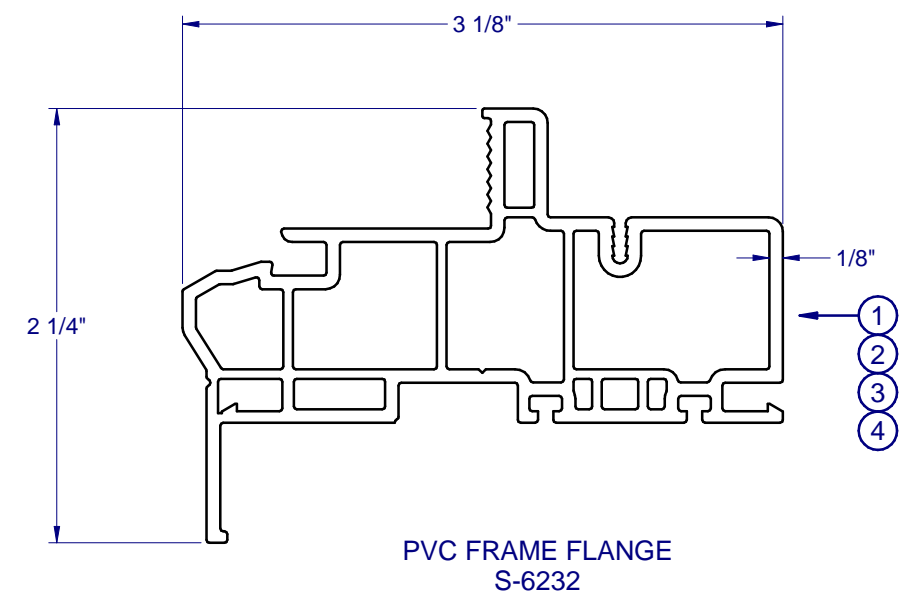

**8300 PVC
PICTURE WINDOW
IMPACT**

PROPRIETARY AND CONFIDENTIAL
THE INFORMATION CONTAINED IN
THIS DRAWING IS THE SOLE
PROPERTY OF CUSTOM WINDOW
SYSTEMS, INC. ANY
REPRODUCTION IN PART OR AS A
WHOLE WITHOUT THE WRITTEN
PERMISSION OF CUSTOM WINDOW
SYSTEMS, INC IS PROHIBITED.

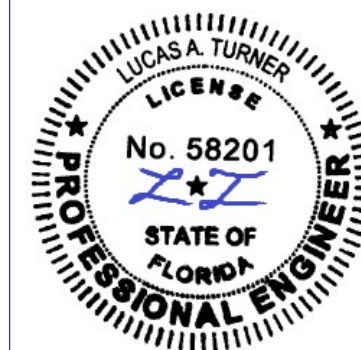

8/05/2020

LUCAS A. TURNER, P.E.
FL PE # 58201
2428 Old Natchez Trc Trl
Camden, TN 38320
PH. 941-380-1574

SHEET DESCRIPTION:
**ANCHOR SCHEDULE AND
NOTES**

DRAWN BY: EMK	DATE: 10/07/14
DWG #: CWS-1033	REV.: C
SCALE: 1:1	SHEET 5 OF 6

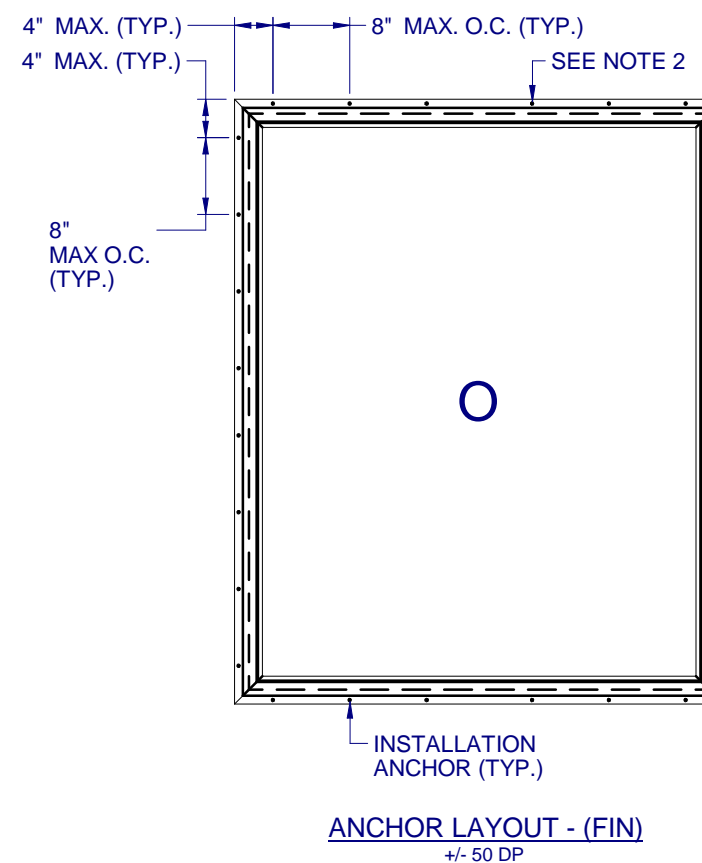
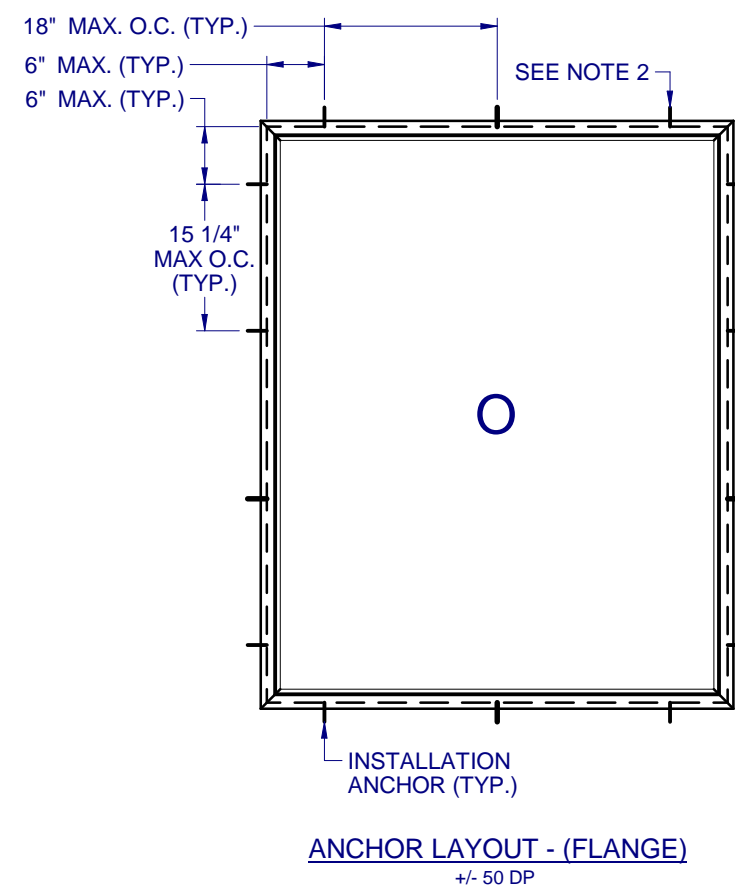
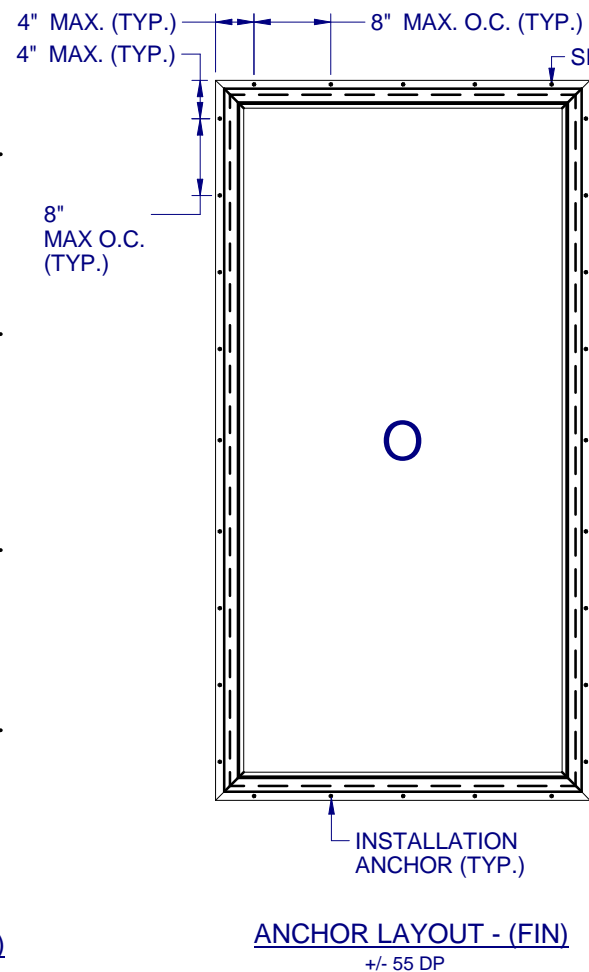
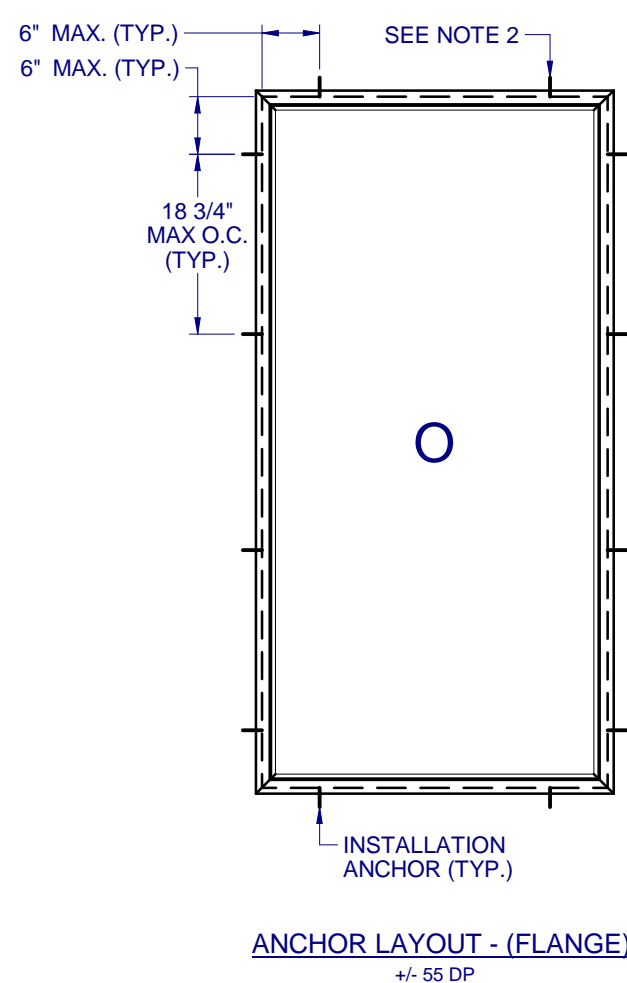

NOTES:

1. INSTALL ONE ANCHOR AT EACH INSTALLATION LOCATION. ANCHOR SPACING APPLIES TO ALL SHAPES (SEE SHEET 2) ALONG ALL FRAME EDGES. SILL ANCHOR SPACING SAME AS HEAD.
2. SHIM AS REQ AT EACH INSTALLATION ANCHOR USING LOAD BEARING SHIMS. MAX. ALLOWABLE SHIM STACK TO BE 1/4". USE SHIMS WHERE SPACE GREATER THAN 1/16" IS PRESENT. LOAD BEARING SHIMS SHALL BE CONSTRUCTED OF HIGH DENSITY PLASTIC OR BETTER. WOOD SHIMS ARE NOT ALLOWED.
3. ANCHOR TYPE, SIZE, SPACING AND EMBEDMENT SHALL BE AS SPECIFIED IN THESE DRAWINGS, SEE TABLE 1, SHEET 6.
4. ALL INSTALLATION ANCHORS MUST BE MADE OF OR PROTECTED WITH A CORROSION RESISTANT MATERIAL OR COATING. DISSIMILAR METALS OR MATERIALS IN CONTACT WITH PRESSURE TREATED WOOD MUST BE PROTECTED TO PREVENT REACTION.
5. INSTALLATION ANCHORS SHALL BE IN ACCORDANCE WITH ANCHOR MANUFACTURER'S INSTALLATION INSTRUCTIONS, AND ANCHORS SHALL NOT BE USED IN SUBSTRATES WITH STRENGTHS LESS THAN THE MINIMUM SPECIFIED IN TABLE 1, SHEET 6.
6. ANCHOR EMBEDMENT TO SUBSTRATE SHALL BE BEYOND WALL DRESSING OR STUCCO. FOR CONCRETE/CMU OPENINGS, EMBEDMENT SHALL BE BEYOND WOOD BUCKS, IF USED, INTO SUBSTRATE. INSTALLATIONS TO SOLID CONCRETE OR GROUT-FILLED CMU MAY INCLUDE BUT DO NOT REQUIRE 1X WOOD BUCKS BETWEEN THE PRODUCT AND SUBSTRATE. INSTALLATIONS TO HOLLOW CMU REQUIRE THE USE OF 1X BUCKS BETWEEN THE PRODUCT AND SUBSTRATE.
7. A MINIMUM CENTER-TO-CENTER SPACING SHALL BE MAINTAINED BETWEEN ALL FASTENERS: 3" FOR MASONRY, 1" FOR WOOD AND METAL.
8. WOOD OR MASONRY OPENINGS, BUCKS AND BUCK FASTENERS SHALL BE PROPERLY DESIGNED BY THE ARCHITECT OR ENGINEER OF RECORD AND INSTALLED TO TRANSFER WIND LOADS TO THE STRUCTURE. SUBSTRATES SHALL MEET THE MINIMUM STRENGTH REQUIREMENTS AS SHOWN IN TABLE 1, SHEET 6. CONCRETE AND MASONRY SUBSTRATES MAY NOT BE CRACKED.
9. SEALING AND FLASHING STRATEGIES FOR OVERALL WATER RESISTANCE OF INSTALLATION SHALL BE DONE BY OTHERS FOLLOWING THE CURRENT VERSION OF THE REFERENCE DOCUMENTS: FMA/AAMA 100(FIN WINDOWS), FMA/AAMA 200(FLANGE WINDOWS), FMA/WDMA 250(BOX WINDOWS), FMA/AAMA/WDMA 300(EXTERIOR DOORS)

**8300 PVC
PICTURE WINDOW
IMPACT**

PROPRIETARY AND CONFIDENTIAL
THE INFORMATION CONTAINED IN THIS DRAWING IS THE SOLE PROPERTY OF CUSTOM WINDOW SYSTEMS, INC. ANY REPRODUCTION IN PART OR AS A WHOLE WITHOUT THE WRITTEN PERMISSION OF CUSTOM WINDOW SYSTEMS, INC IS PROHIBITED.

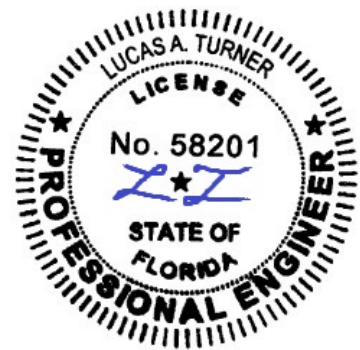

8/05/2020

LUCAS A. TURNER, P.E.
FL PE # 58201
2428 Old Natchez Trc Trl
Camden, TN 38320
PH. 941-380-1574

SHEET DESCRIPTION:

INSTALLATION DETAILS

DRAWN BY:	DATE:
EMK	10/07/14
DWG #:	REV.:
CWS-1033	C
SCALE:	SHEET
1:2	6 OF 6

TYPICAL HEAD ANCHORAGE

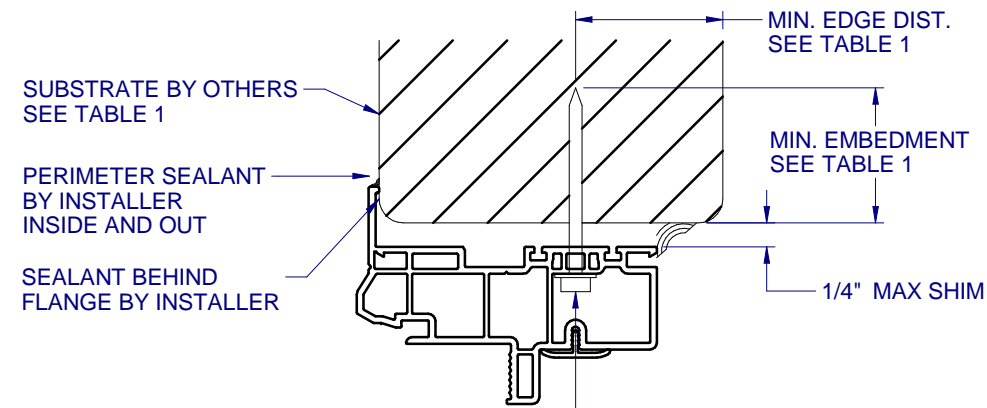

INSTALLATION ANCHOR
SEE TABLE 1

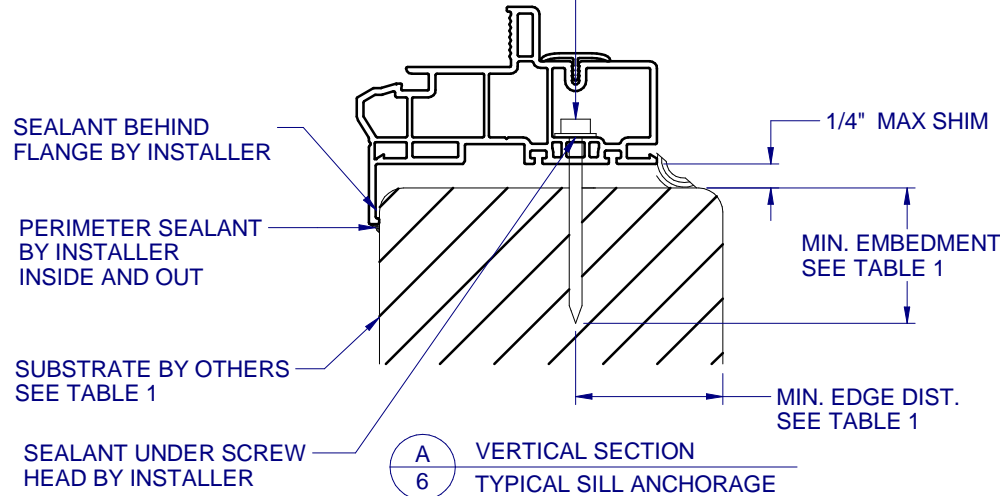

A VERTICAL SECTION
6 TYPICAL SILL ANCHORAGE

MIN. EMBEDMENT
SEE TABLE 1

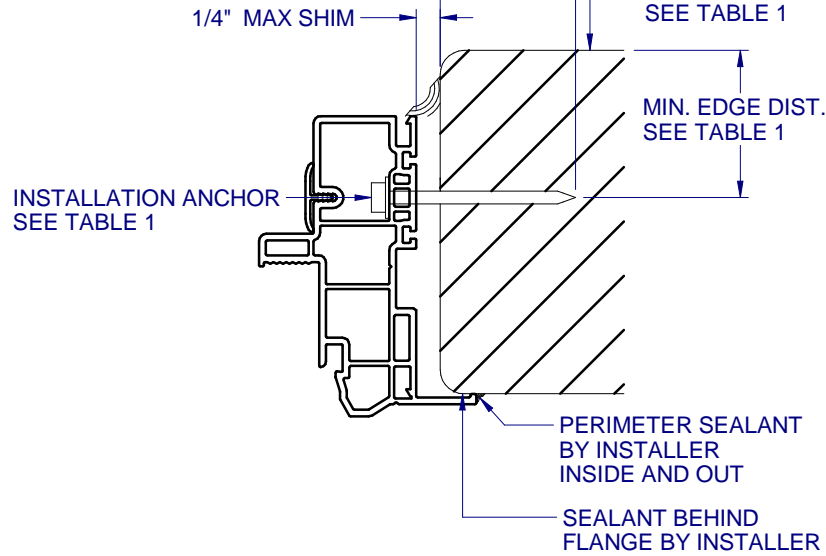

B HORIZONTAL SECTION
6 TYPICAL JAMB ANCHORAGE

MIN. EDGE DIST.
SEE TABLE 1
1/4\"/>

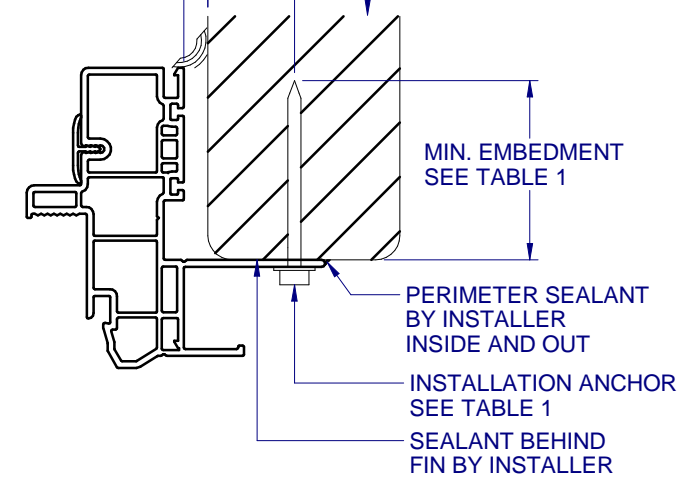

C HORIZONTAL SECTION
6 TYPICAL FIN ANCHORAGE
HEAD AND SILL SIMILAR FOR FIN INSTALLATION

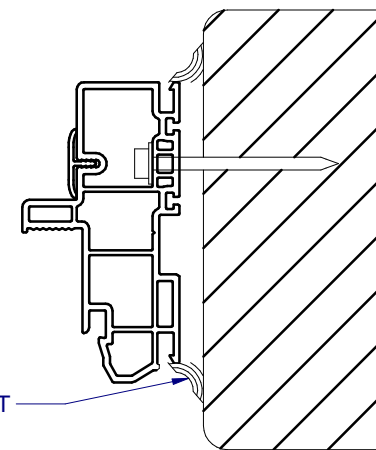

D HORIZONTAL SECTION
6 BOX FRAME INSTALLATION
HEAD AND SILL SIMILAR FOR BOX INSTALLATION

FLANGE REMOVAL NOTE: PARTIALLY OR FULLY REMOVING THE FLANGE, UP TO AND INCLUDING A BOX-FRAME APPLICATION IS ACCEPTABLE PROVIDED:

- MIN. 1/4" FILLET OF CONSTRUCTION-GRADE ADHESIVE CAULK IS APPLIED INSIDE AND OUT, FULL PERIMETER, BY INSTALLER.
- PRODUCT ANCHORAGE IS IN ACCORDANCE WITH REQUIREMENTS AS SHOWN FOR FLANGE WINDOWS.

TABLE 1: APPROVED INSTALLATION FASTENERS

FRAME TYPE	SUBSTRATE TYPE	ANCHOR TYPE	MIN. EMBEDMENT	MIN. EDGE DIST.
FLANGE	CONCRETE (2.0 KSI MIN.)	3/16" ITW TAPCON	1-1/2"	1-1/8"
FLANGE	HOLLOW OR GROUT-FILLED CMU (117 PCF MIN.)	3/16" ITW TAPCON	1"	2"
FLANGE	CONCRETE (2.85 KSI MIN.)	3/16" ELCO ULTRACON	1"	1"
FLANGE	GROUT-FILLED CMU (ASTM C-90)	3/16" ELCO ULTRACON	1-1/4"	2-1/2"
FLANGE	2X MIN. SOUTHERN PINE (G=0.55)	3/16" ITW TAPCON OR ELCO ULTRACON	1-3/8"	7/8"
FLANGE	2X MIN. SOUTHERN PINE (G=0.55)	#10 WOOD SCREW	1-3/8"	7/8"
FLANGE	16 GAUGE (0.060") MIN. STEEL STUD (33 KSI YIELD MIN)	#10-16 HILTI KWIK-FLEX OR ITW TEKS SELF-DRILLING SCREW	FULL THREAD THRU 0.060"	7/16"
FLANGE	1/8" ALUM. (6063-T5 MIN.) OR 1/8" STEEL (33 KSI MIN.)	#10 GRADE 5 SELF-TAPPING / DRILLING SCREW	FULL THREAD THRU 0.125"	7/16"
FIN	2X MIN. SOUTHERN PINE (G=0.55)	#8 WOOD SCREW	1-1/2"	7/16"