

CASEMENT - LARGE MISSILE IMPACT

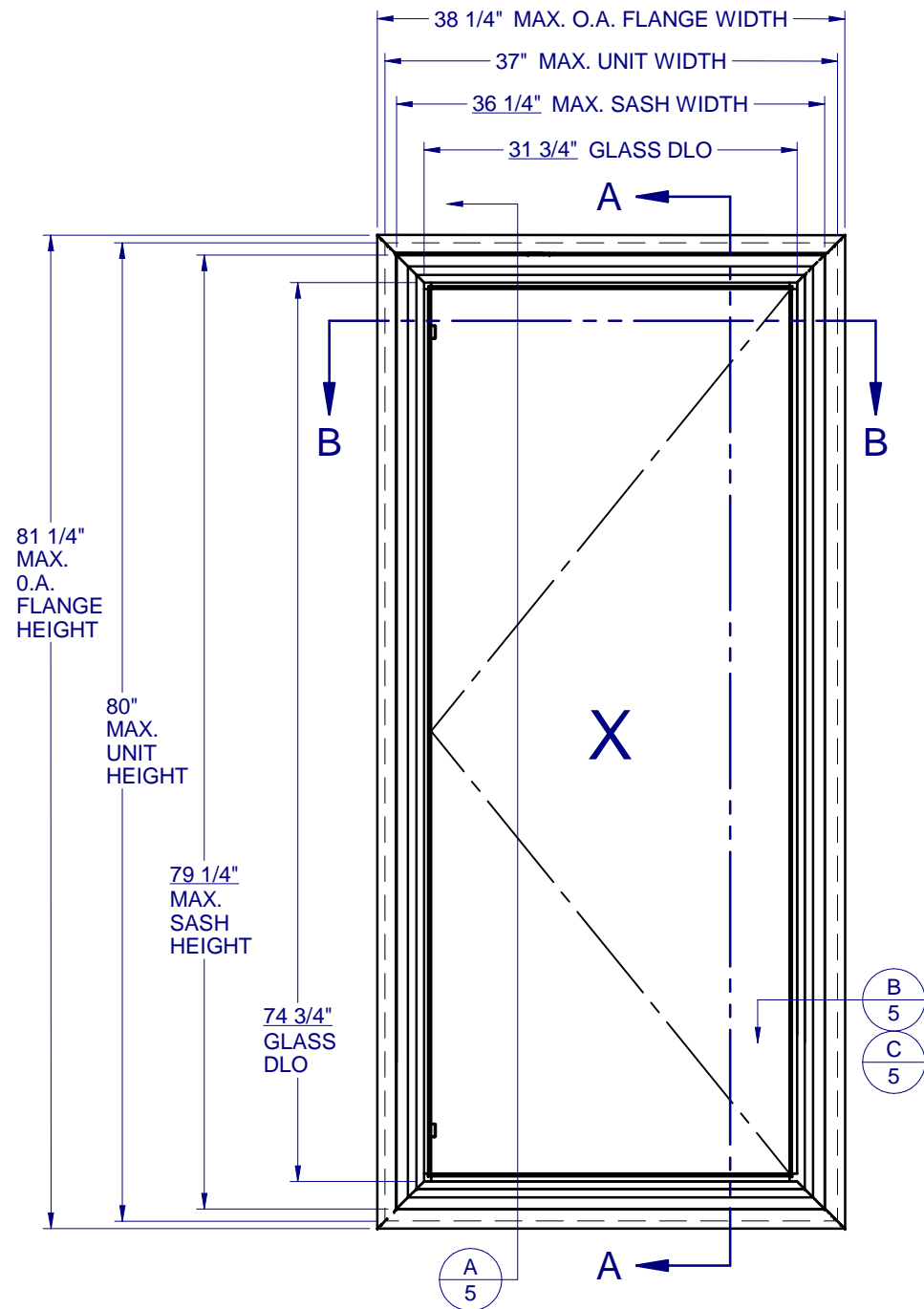

LEFT HINGED - SHOWN
RIGHT HINGED - OPPOSITE

GENERAL NOTES:

1. THE PRODUCT SHOWN HEREIN IS DESIGNED AND MANUFACTURED TO COMPLY WITH THE FLORIDA BUILDING CODE (FBC), CURRENT EDITION INCLUDING THE HIGH VELOCITY HURRICANE ZONE (HVHZ) AND IS RATED FOR WIND ZONE 4 MISSILE LEVEL D IMPACT USE AS DEFINED IN ASTM E 1996 PER THE FBC.
2. GLAZING OPTIONS: (SEE SHEET 2)
3. CONFIGURATIONS: ALL WINDOWS ARE OPEN TO OUTSIDE LEFT OR RIGHT.
4. DESIGN PRESSURES:
-NEGATIVE DESIGN LOADS BASED ON TESTED PRESSURE AND GLASS TABLES ASTM E-1300-04e01/09.
-POSITIVE DESIGN LOADS BASED ON TESTED PRESSURE, WATER INFILTRATION TEST PRESSURE, AND GLASS TABLES ASTM E-1300-04e01/09.
5. ANCHORAGE: THE 33 1/3% STRESS INCREASE HAS NOT BEEN USED IN THE DESIGN OF THIS PRODUCT. SEE SHEET 5 FOR INSTALLATION DETAIL. WIND LOAD DURATION FACTOR Cd=1.6 WAS USED FOR WOOD ANCHOR CALCULATIONS.
6. PRODUCTS APPROVED FOR IMPACT RESISTANCE. SHUTTERS ARE NOT REQUIRED.
7. ALL FRAMES AND VENTS FULLY WELDED.
8. SERIES/MODEL DESIGNATION CA-8400.
9. THE DESIGNATION X STANDS FOR THE FOLLOWING:
X = OPERABLE SASH
10. SECTION CALLOUTS APPLY TO ALL ELEVATIONS IN A SIMILAR LOCATION.



1900 SW 44TH AVE.
OCALA, FLORIDA 34474
WWW.CWS.CC

8400 PVC CASEMENT IMPACT

PROPRIETARY AND CONFIDENTIAL
THE INFORMATION CONTAINED IN THIS DRAWING IS THE SOLE PROPERTY OF CUSTOM WINDOW SYSTEMS, INC. ANY REPRODUCTION IN PART OR AS A WHOLE WITHOUT THE WRITTEN PERMISSION OF CUSTOM WINDOW SYSTEMS, INC IS PROHIBITED.

FLORIDA APPROVAL NO.:
17388



8/15/2023

LUCAS A. TURNER, P.E.
FL PE # 58201
Turner Engineering & Consulting, Inc.
2428 Old Natchez Trc Trl
Camden, TN 38320
PH. 941-380-1574

SHEET DESCRIPTION:

GENERAL NOTES AND ELEVATIONS

DRAWN BY: MCS	DATE: 8/9/2023
DWG #: CWS-999	REV.: D
SCALE: 1:15	SHEET 1 OF 5

TABLE OF CONTENTS

GENERAL NOTES & ELEVATIONS.....	1
SECTION VIEWS & GLAZING DETAIL....	2
BOM & EXTRUSIONS.....	3
ANCHOR SCHEDULE & NOTES.....	4
INSTALLATION DETAILS.....	5

MAX. UNIT SIZE	DESIGN PRESSURE RATING	IMPACT RATING
37" x 80"	+/- 70 PSF	LARGE MISSILE IMPACT



1900 SW 44TH AVE.
OCALA, FLORIDA 34474
WWW.CWS.CC

8400 PVC CASEMENT IMPACT

PROPRIETARY AND CONFIDENTIAL
THE INFORMATION CONTAINED IN
THIS DRAWING IS THE SOLE
PROPERTY OF CUSTOM WINDOW
SYSTEMS, INC. ANY
REPRODUCTION IN PART OR AS A
WHOLE WITHOUT THE WRITTEN
PERMISSION OF CUSTOM WINDOW
SYSTEMS, INC IS PROHIBITED.

FLORIDA APPROVAL NO.:
17388



8/15/2023

LUCAS A. TURNER, P.E.
FL PE # 58201
Turner Engineering &
Consulting, Inc.
2428 Old Natchez Trc Trl
Camden, TN 38320
PH. 941-380-1574

SHEET DESCRIPTION:

SECTION VIEWS AND GLAZING DETAIL

DRAWN BY: MCS	DATE: 8/9/2023
DWG #: CWS-999	REV.: D
SCALE: 1:2	SHEET 2 OF 5

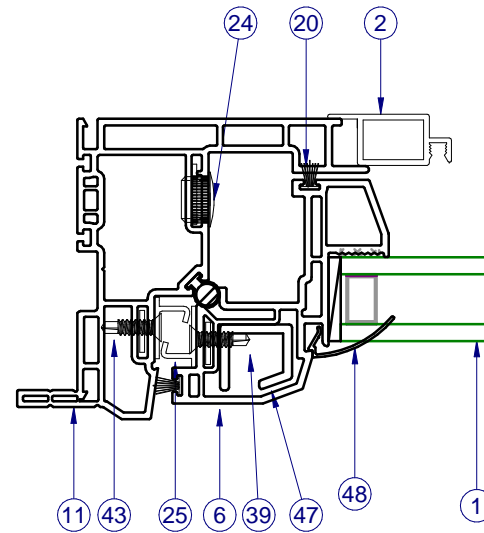

INTERIOR

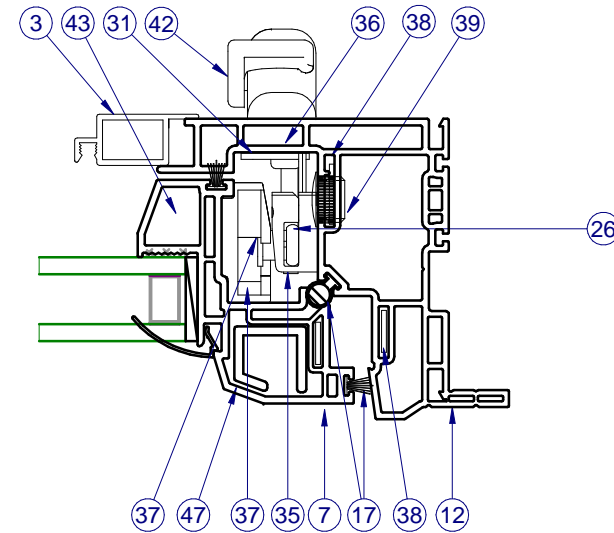

SECTION VIEW B-B

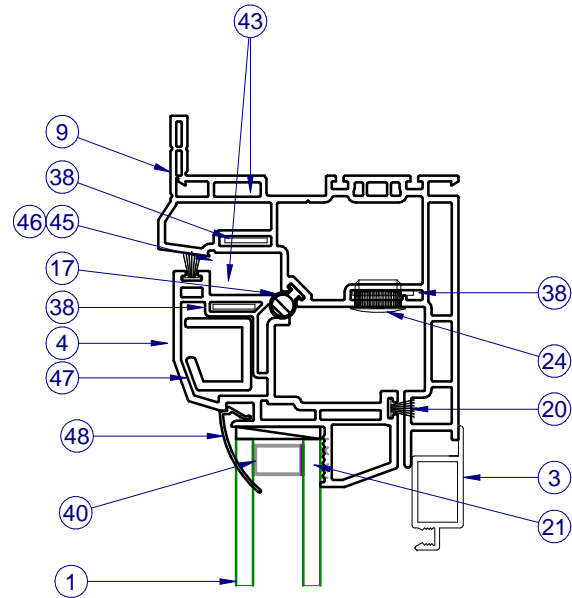

INTERIOR

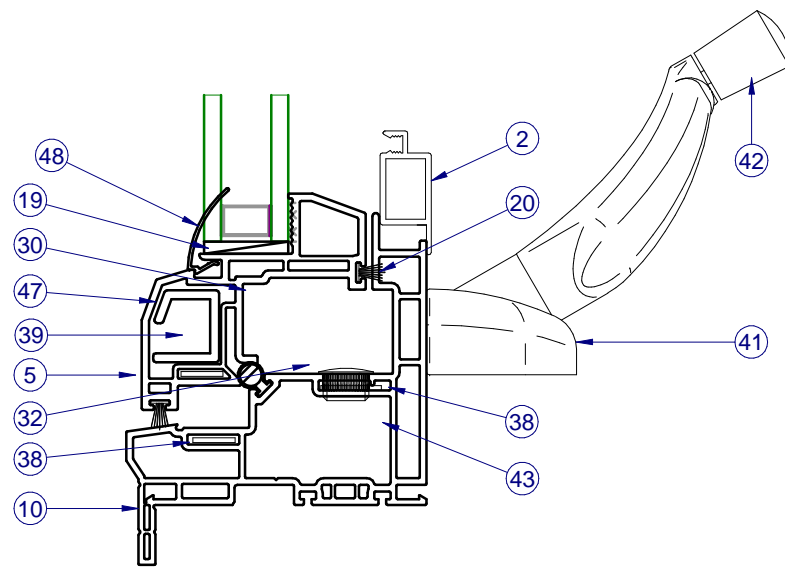

SECTION VIEW A-A

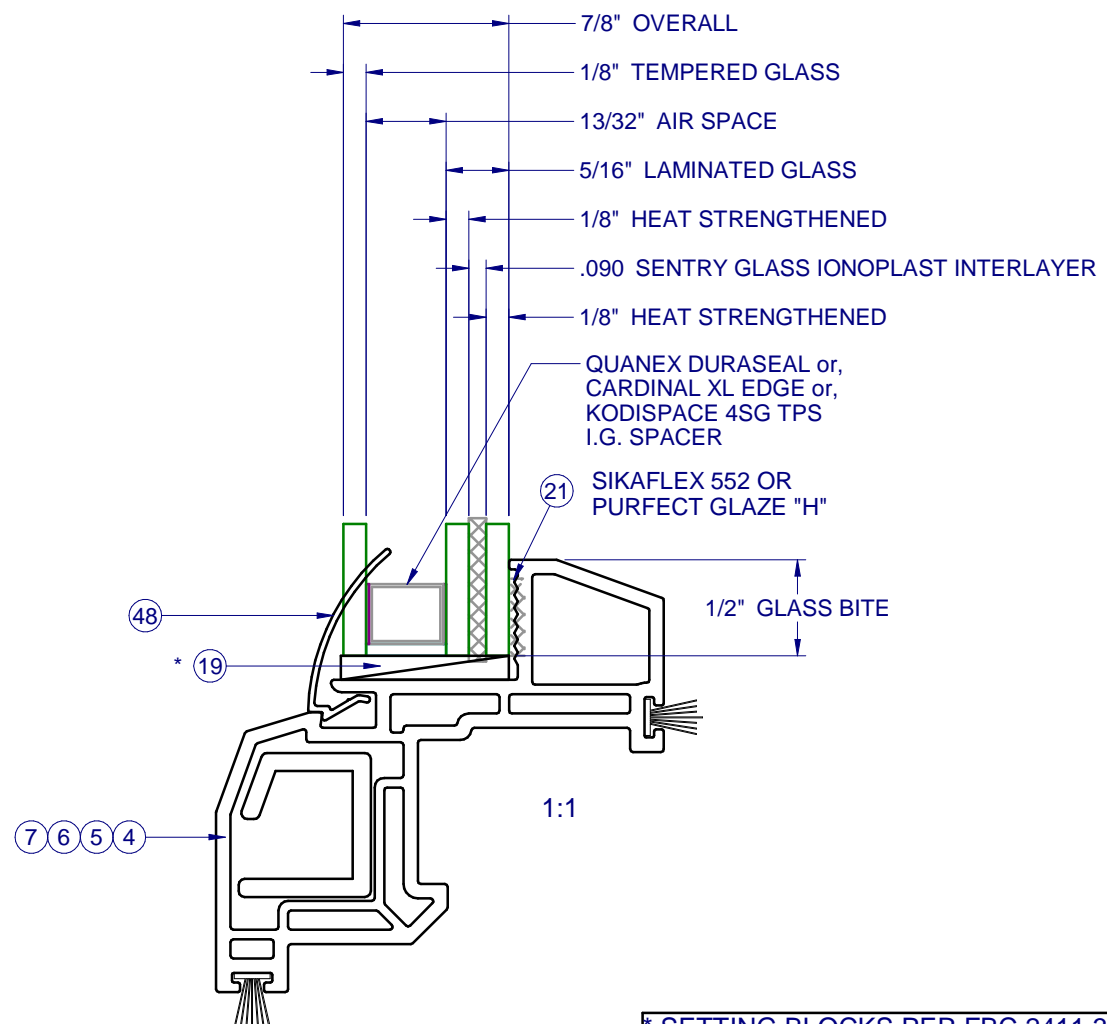

* SETTING BLOCKS PER FBC 2411.3.3.1

ITEMS NOT SHOWN FOR CLARITY:
13, 15, 16, 18, 22, 23, 27-29, 31, 33-37, 44, 46

ITEM	PART #	DESCRIPTION	MATERIAL
1	GLASS	SEE SHEET 2	
2	H-1592	SCREEN RAIL, SIDE/BTM.	ALUM
3	H-1593	SCREEN RAIL, TOP/SIDE	ALUM
4	H-6234	SASH, CASEMENT, TOP RAIL	PVC
5	H-6234	SASH, CASEMENT, BTM. RAIL	PVC
6	H-6234	SASH, CASEMENT, SIDE RAIL, HINGE	PVC
7	H-6234	SASH, CASEMENT, SIDE RAIL, LOCK	PVC
9	H-6235	FRAME, CASEMENT, MAIN, HEAD	PVC
10	H-6235	FRAME, CASEMENT, MAIN, SILL	PVC
11	H-6235	FRAME, CASEMENT, MAIN, L. JAMB	PVC
12	H-6235	FRAME, CASEMENT, MAIN, R. JAMB	PVC
13	P-4755	Screen Corner Key W/ Safety Pull Tab	
15	P-3195	SCREEN SPRING, NO HOLE TENSION	
16	P-3197	SCREEN CORNER KEY	NYLON
17	P-5573	WSTP., BULB, HOLLOW, T-SLOT, .187 X .358	RUBBER
18	P-3228	SCREEN SPLINE, 0.155 DIA., BLACK	
19	P-5612	Setting Block, .12 x 1 x 2	RUBBER
20	P-3305	WSTP., .270" x .187" High Density	
21		PURFECT GLAZE "H" OR SIKAFLEX 552	SILICONE
22	P-3565	36" - 18X14 CHARCOAL SCREEN	
23	P-3587	#8 X 1" PH FH TEK 2, ZINC, SCREW	SS
24	P-5588	CAP PLUG, 1/2" HOLE	NYLON
25	P-3940	SNUBBER, SS, PVC	SS
26	P-4003	TIE BAR GUIDE, ROTO. HDWE.	SS
27	P-4004	#8-32 X 1/2" PH PH, MS, SS (ROTO HDWE. LOCK)	SS
28	P-4005	SUPPORT PLATE, LOCK, SS, ROTO HDWE. (Use w/ P-4006)	NYLON
29	P-4006	LOCK, MULTI-POINT, ROTO HDWE., WHITE	ZINC
30	P-4009	TRACK & SLIDER ASSM., ROTO OPER., ROTO HDWE., (13")	SS
31	P-4011	STUD BRKT., ROTO OPER., R.H., ROTO HDWE.	SS
32	P-4012	SHIM, ROTO OPERATOR, ROTO HDWE. (4.8mm)	NYLON
33	P-4020	SUPPORT WASHER, ROTO OPER, ROTO HDWE. (SS)	SS
34	P-4024	GASKET, ROTO OPER., ROTO HDWE., 1/16"	CLIP FOAM
35	P-4038	TIE-BARS, ROTO HDWE. 1-5 LOCKPOINTS, SS (BY OA HGT.)	SS
36	P-4042	GASKET, FOR MULTI-POINT LOCK (P-4006), ROTO HDWE.	CLIP FOAM
37	P-4043	STRIKE, MULTI-POINT	NYLON
38	P-4050	REINF. COIL-ALUMINUM, 5052-H32 (.050" x .437") HD	ALUM
39	P-4146	#8 X 3/4" PHIL FLAT TEK	SS
40		SPACER, SEE SHEET 2	
41	P-4502	ROTO. OPERATORS (FOR LEFT/RIGHT OPEN CASEMENT)	SS
42	P-4503	ROTO OPER., DUAL ARM, R.H., ROTO HDWE. (X-Drive SS)	SS
43	P-4641	#8 X 5/8" PHIL FLAT TEK	SS
44	P-4658	SASH LIMITER, CASEMENT, SS	SS
45	P-4015	HINGE ARM, WASHABILITY 13 INCH (ROTO HDWE)(>100 lb sa	SS
46	P-4018	HINGE TRACK, 13 INCH (ROTO HDWE)(over 100 lb sash)	SS
47	S-1505	REINF. CASE.	ALUM
48	S-6237	GLAZING BEAD	PVC

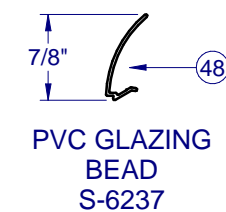
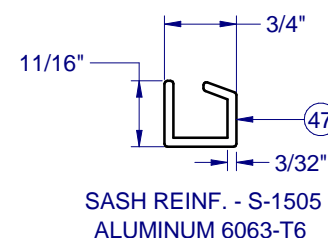
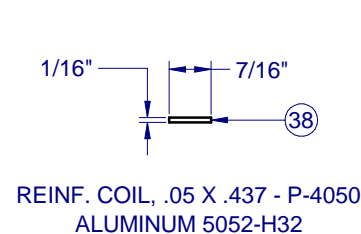
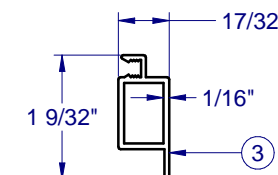
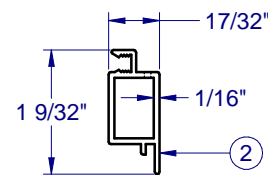
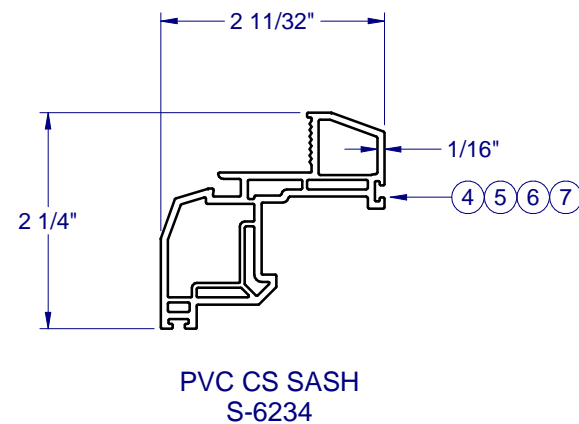
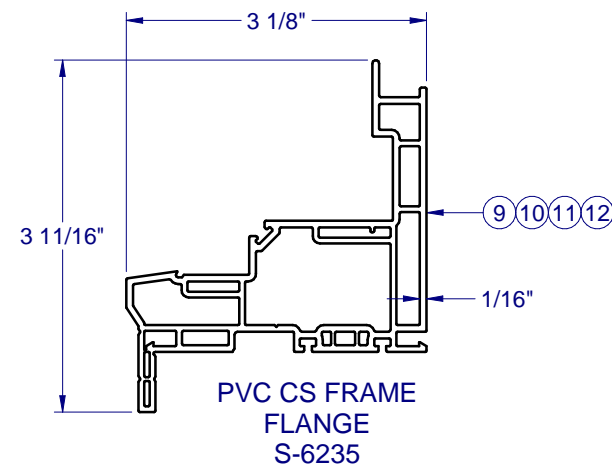

FRAME & SASH CORNER CONSTRUCTION

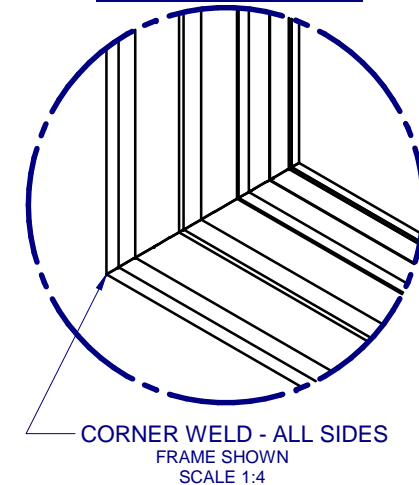

8400 PVC CASEMENT IMPACT

PROPRIETARY AND CONFIDENTIAL
THE INFORMATION CONTAINED IN THIS DRAWING IS THE SOLE PROPERTY OF CUSTOM WINDOW SYSTEMS, INC. ANY REPRODUCTION IN PART OR AS A WHOLE WITHOUT THE WRITTEN PERMISSION OF CUSTOM WINDOW SYSTEMS, INC IS PROHIBITED.

FLORIDA APPROVAL NO.: 17388

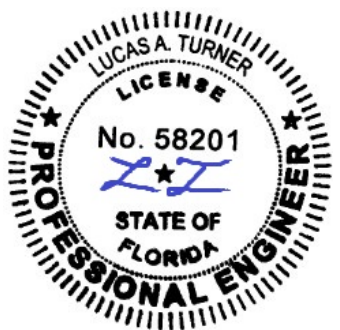

8/15/2023

LUCAS A. TURNER, P.E.
FL PE # 58201
Turner Engineering & Consulting, Inc.
2428 Old Natchez Trc Trl
Camden, TN 38320
PH. 941-380-1574

SHEET DESCRIPTION:

BOM AND EXTRUSIONS

DRAWN BY: MCS	DATE: 8/9/2023
DWG #: CWS-999	REV.: D
SCALE: 1:2	SHEET 3 OF 5

**8400 PVC
CASEMENT
IMPACT**

PROPRIETARY AND CONFIDENTIAL
THE INFORMATION CONTAINED IN
THIS DRAWING IS THE SOLE
PROPERTY OF CUSTOM WINDOW
SYSTEMS, INC. ANY
REPRODUCTION IN PART OR AS A
WHOLE WITHOUT THE WRITTEN
PERMISSION OF CUSTOM WINDOW
SYSTEMS, INC IS PROHIBITED.

FLORIDA APPROVAL NO.:
17388



8/15/2023

LUCAS A. TURNER, P.E.
FL PE # 58201
Turner Engineering &
Consulting, Inc.
2428 Old Natchez Trc Trl
Camden, TN 38320
PH. 941-380-1574

SHEET DESCRIPTION:

**ANCHOR SCHEDULE AND
NOTES**

DRAWN BY: MCS	DATE: 8/9/2023
DWG #: CWS-999	REV.: D
SCALE: 1:20	SHEET 4 OF 5

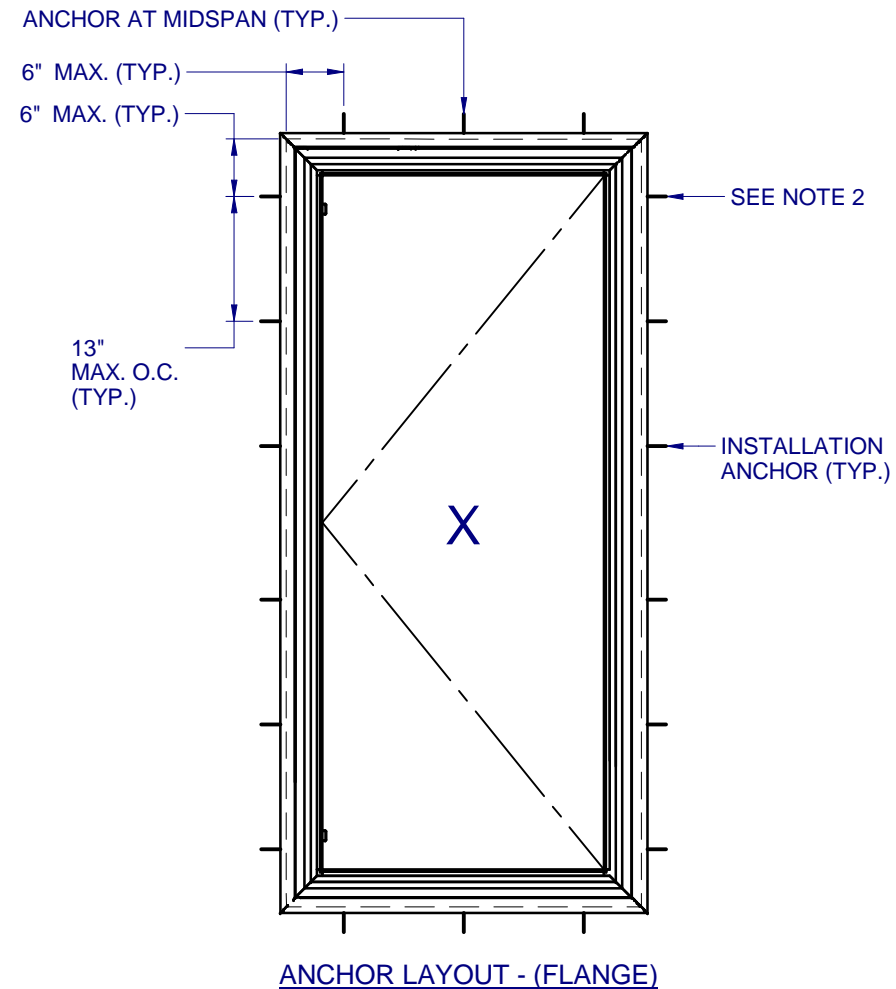

NOTES:

1. INSTALL ONE ANCHOR AT EACH INSTALLATION LOCATION. SILL ANCHOR SPACING SAME AS HEAD.
2. SHIM AS REQ AT EACH INSTALLATION ANCHOR USING LOAD BEARING SHIMS. MAX. ALLOWABLE SHIM STACK TO BE 1/4". USE SHIMS WHERE SPACE GREATER THAN 1/16" IS PRESENT. LOAD BEARING SHIMS SHALL BE CONSTRUCTED OF HIGH DENSITY PLASTIC OR BETTER. WOOD SHIMS ARE NOT ALLOWED.
3. ANCHOR TYPE, SIZE, SPACING AND EMBEDMENT SHALL BE AS SPECIFIED IN THESE DRAWINGS, SEE TABLE 1, SHEET 5.
4. ALL INSTALLATION ANCHORS MUST BE MADE OF OR PROTECTED WITH A CORROSION RESISTANT MATERIAL OR COATING. DISSIMILAR METALS OR MATERIALS IN CONTACT WITH PRESSURE TREATED WOOD MUST BE PROTECTED TO PREVENT REACTION.
5. INSTALLATION ANCHORS SHALL BE IN ACCORDANCE WITH ANCHOR MANUFACTURER'S INSTALLATION INSTRUCTIONS, AND ANCHORS SHALL NOT BE USED IN SUBSTRATES WITH STRENGTHS LESS THAN THE MINIMUM SPECIFIED IN TABLE 1, SHEET 5.
6. ANCHOR EMBEDMENT TO SUBSTRATE SHALL BE BEYOND WALL DRESSING OR STUCCO. FOR CONCRETE/CMU OPENINGS, EMBEDMENT SHALL BE BEYOND WOOD BUCKS, IF USED, INTO SUBSTRATE. INSTALLATIONS TO SOLID CONCRETE OR GROUT-FILLED CMU MAY INCLUDE BUT DO NOT REQUIRE 1X WOOD BUCKS BETWEEN THE PRODUCT AND THE SUBSTRATE. INSTALLATIONS TO HOLLOW CMU REQUIRE THE USE OF 1X BUCKS BETWEEN THE PRODUCT AND SUBSTRATE.
7. A MINIMUM CENTER-TO-CENTER SPACING SHALL BE MAINTAINED BETWEEN ALL FASTENERS: 3" FOR MASONRY, 1" FOR WOOD AND METAL.
8. WOOD OR MASONRY OPENINGS, BUCKS AND BUCK FASTENERS SHALL BE PROPERLY DESIGNED BY THE ARCHITECT OR ENGINEER OF RECORD AND INSTALLED TO TRANSFER WIND LOADS TO THE STRUCTURE. SUBSTRATES SHALL MEET THE MINIMUM STRENGTH REQUIREMENTS AS SHOWN IN TABLE 1, SHEET 5. CONCRETE AND MASONRY SUBSTRATES MAY NOT BE CRACKED.
9. SEALING AND FLASHING STRATEGIES FOR OVERALL WATER RESISTANCE OF INSTALLATION SHALL BE DONE BY OTHERS FOLLOWING THE CURRENT VERSION OF THE REFERENCE DOCUMENTS:
FMA/AAMA 100(FIN WINDOWS), FMA/AAMA 200(FLANGE WINDOWS), FMA/WDMA 250(BOX WINDOWS), FMA/AAMA/WDMA 300(EXTERIOR DOORS)

8400 PVC CASEMENT IMPACT

PROPRIETARY AND CONFIDENTIAL
THE INFORMATION CONTAINED IN THIS DRAWING IS THE SOLE PROPERTY OF CUSTOM WINDOW SYSTEMS, INC. ANY REPRODUCTION IN PART OR AS A WHOLE WITHOUT THE WRITTEN PERMISSION OF CUSTOM WINDOW SYSTEMS, INC IS PROHIBITED.

FLORIDA APPROVAL NO.:
17388

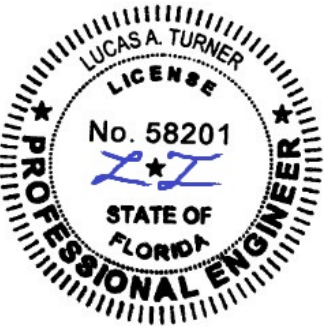

8/15/2023

LUCAS A. TURNER, P.E.
FL PE # 58201
Turner Engineering & Consulting, Inc.
2428 Old Natchez Trc Trl
Camden, TN 38320
PH. 941-380-1574

SHEET DESCRIPTION:

INSTALLATION DETAILS

DRAWN BY:	DATE:
MCS	8/9/2023
DWG #:	REV.:
CWS-999	D
SCALE:	SHEET
1:2	5 OF 5

TYPICAL HEAD ANCHORAGE

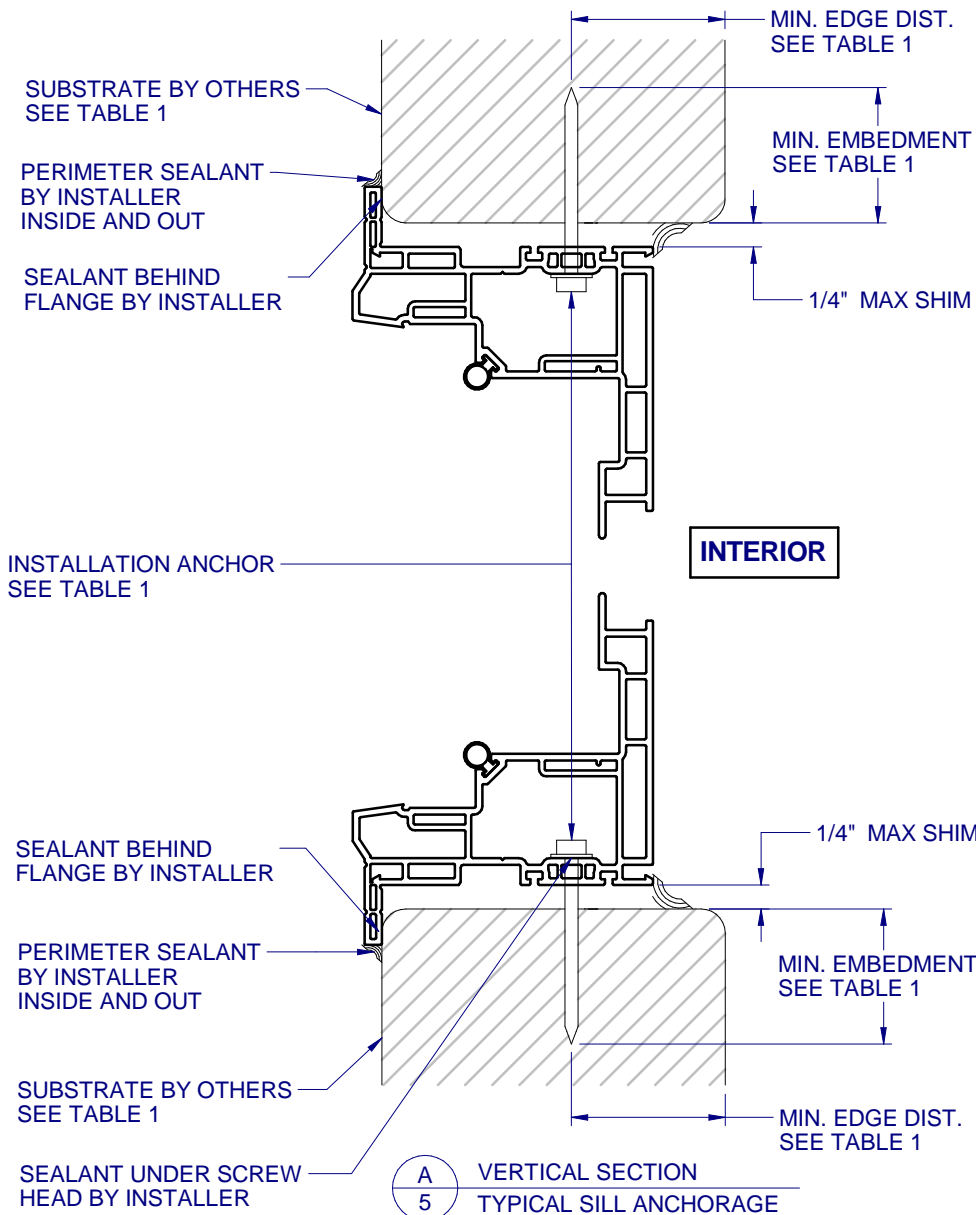

(A) VERTICAL SECTION
5 TYPICAL SILL ANCHORAGE

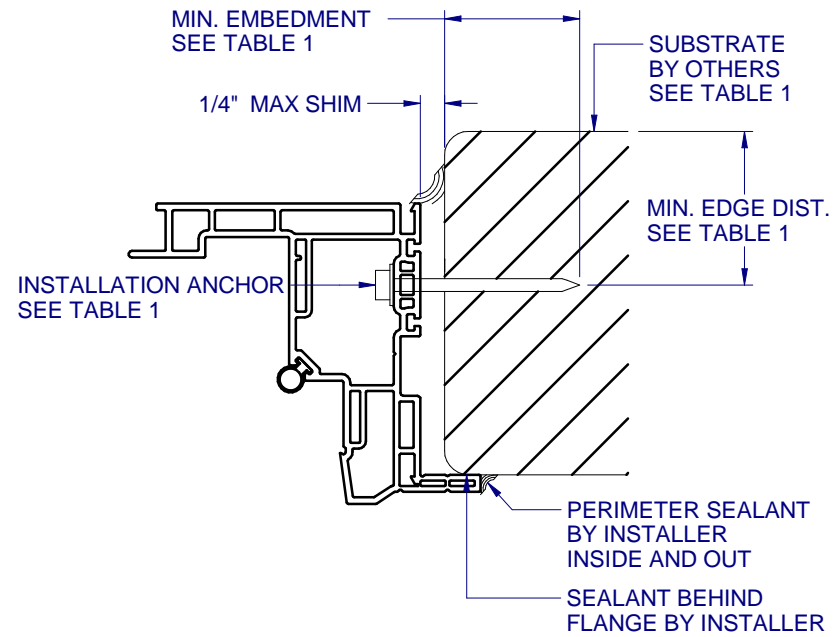

(B) HORIZONTAL SECTION
5 TYPICAL JAMB ANCHORAGE

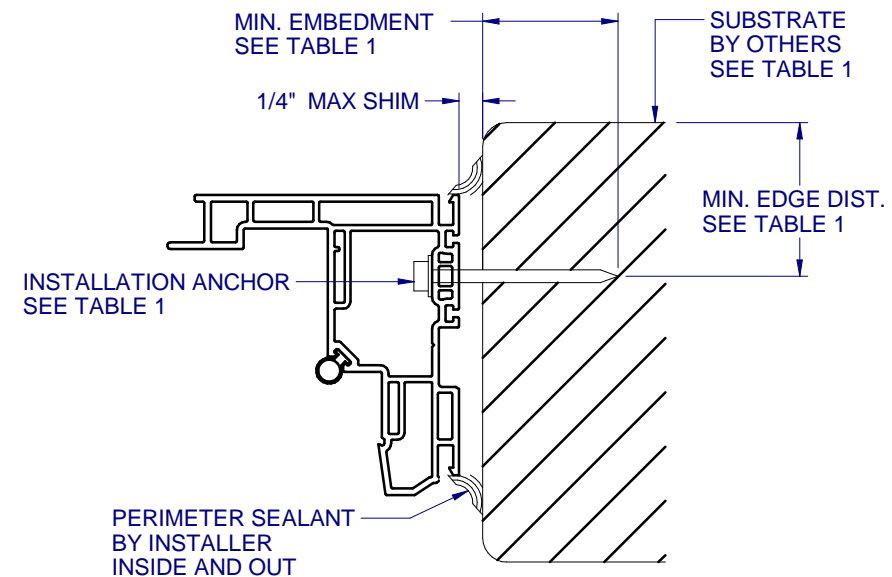

(C) HORIZONTAL SECTION
5 BOX FRAME INSTALLATION HEAD AND SILL SIMILAR FOR BOX INSTALLATION

FLANGE REMOVAL NOTE: PARTIALLY OR FULLY REMOVING THE FLANGE, UP TO AND INCLUDING A BOX-FRAME APPLICATION IS ACCEPTABLE PROVIDED:

- MIN. 1/4" FILLET OF CONSTRUCTION-GRADE ADHESIVE CAULK IS APPLIED INSIDE AND OUT, FULL PERIMETER, BY INSTALLER.
- PRODUCT ANCHORAGE IS IN ACCORDANCE WITH REQUIREMENTS AS SHOWN FOR FLANGE WINDOWS.

TABLE 1: APPROVED INSTALLATION FASTENERS

SUBSTRATE TYPE	ANCHOR TYPE	MIN. EMBEDMENT	MIN. EDGE DIST.
CONCRETE (2.0 KSI MIN.)	3/16" ITW TAPCON	1-1/2"	1-1/8"
HOLLOW OR GROUT-FILLED CMU (117 PCF MIN.)	3/16" ITW TAPCON	1"	2"
CONCRETE (3.05 KSI MIN.)	3/16" DEWALT ULTRACON+	1-3/4"	1"
HOLLOW OR GROUT-FILLED CMU (ASTM C-90)	3/16" DEWALT ULTRACON+	1-1/4"	2-1/2"
2X MIN. SOUTHERN PINE (G=0.55)	3/16" ITW TAPCON OR DEWALT ULTRACON+	1-3/8"	7/8"
2X MIN. SOUTHERN PINE (G=0.55)	#10 WOOD SCREW	1-3/8"	7/8"
16 GAUGE (0.060") MIN. STEEL STUD (33 KSI YIELD MIN)	#10-16 HILTI KWIK-FLEX OR ITW TEKS SELF-DRILLING SCREW	FULL THREAD THRU 0.060"	7/16"
1/8" ALUM. (6063-T5 MIN.) OR 1/8" STEEL (33 KSI MIN.)	#10 GRADE 5 SELF-TAPPING / DRILLING SCREW	FULL THREAD THRU 0.125"	7/16"