

JAMB SCREW THROUGH JAMB INSTALLATION

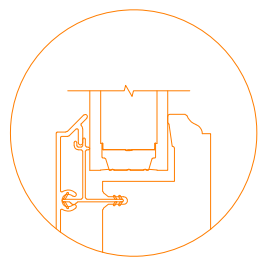

GLAZING DETAIL:
MEETS ASTM E1300

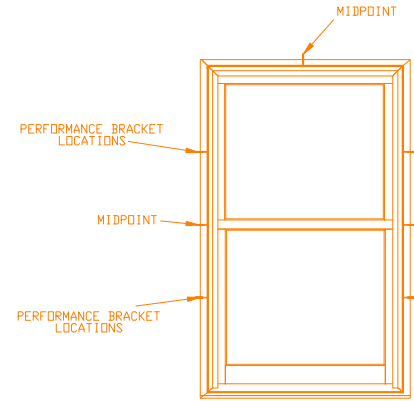
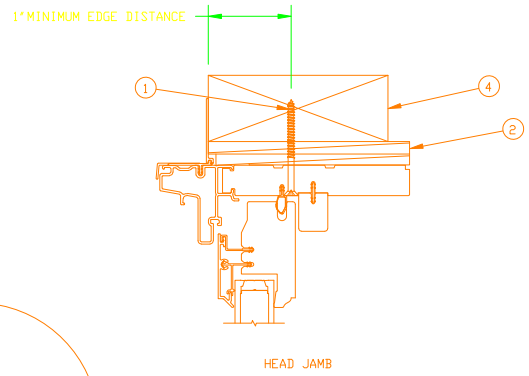
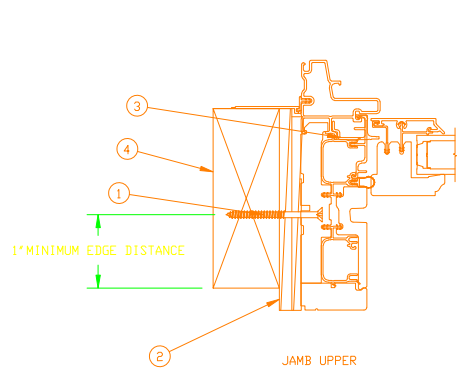
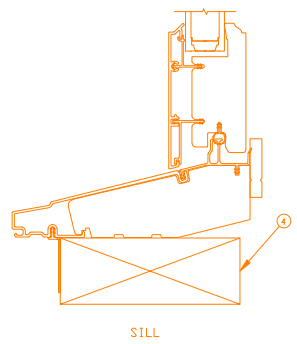
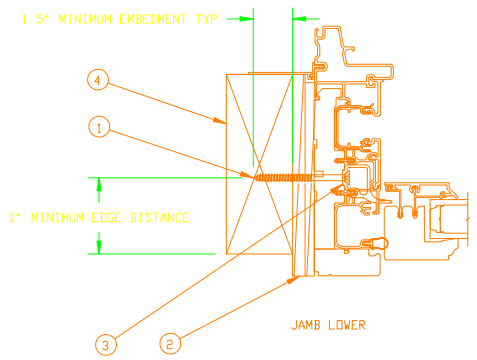

UNIT	MAX FRAME SIZE	DP RATING
UL DBLHNG G2	53 1/4 X 59 1/2	+50/-50

INSTALLATION METHOD:

- NON STRUCTURAL NAIL FIN OPTIONAL FOR PLACEMENT ONLY
- JAMB SCREWS: ONE AT EACH PERFORMANCE BRACKET LOCATION AND ONE AT MIDPOINT OF EACH JAMB.

NOTES:

- THIS PRINT IS FOR STRUCTURAL PERFORMANCE ONLY. FOR FLASHING & SEALING REQUIREMENTS, REFER TO THE INSTALLATION INSTRUCTIONS.
- SHIMS:
- A SHIM MUST BE PLACED AT EACH SCREW LOCATION.
UNIT MUST NOT BE IN DIRECT CONTACT WITH EITHER CONCRETE OR TREATED LUMBER.
- IF SHIM SPACE IS LESS THAN 1/4", WRAP THE UNIT ON ALL 4 SIDES WITH WINDOW FLASHING TAPE AS REQUIRED FOR A BARRIER BETWEEN THE UNIT AND CONCRETE OR TREATED LUMBER.
- IF CHEMICALLY TREATED LUMBER IS USED FOR BUCK MATERIAL, FASTENERS INTO THE BUCK MUST BE A MINIMUM OF 0.90 OZ/FT² ZINC HOT DIPPED GALVANIZED OR STAINLESS STEEL TYPE 304 OR 316.

CATEGORY:
DOUBLE HUNG

UNIT TYPE:
UDHG2

ITEM NO	REF NO	DESCRIPTION
4	-----	2X WOOD BUCK BY OTHERS
3	-----	PERFORMANCE BRACKET
2	-----	SHIM
1	-----	#8 X 3.000 WOOD SCREW

UNSPECIFIED TOLERANCES	
DECIMALS: XX ± .03 XXX ± .012	ANGLE DEG: ± .5
LINEAL: + .125 - .000	FAB LINEAL: ± .125

MATERIAL:
NA

MARVIN 		RESEARCH & DEVELOPMENT	
COLLECTION: ULTIMATE			
DWG TYPE: INSTALLATION			
DESCRIPTION: SCREW THRU JAMB			
CHK:	SIZE: B	CLASS: MISC	DWG NO: 00130152
APP:	SCALE: NA	DATE: 11/16/2021	DWG BY: KOMPELIEN, SARA
			SHEET: 1 OF 1

NOTICE - CONFIDENTIAL INFORMATION

The information in this document is privileged and strictly confidential. The information contained herein shall be used only by Marvin Windows and Doors employees and by those agents or suppliers granted official written permission. If the reader of this document is not the intended recipient, or the employee or agent of the intended recipient, please delete this document from all data storage devices, and destroy all hard copies. Any unauthorized dissemination, distribution, copying or other use of the information contained in this document is strictly prohibited.