

SINGLE HUNG ORIEL - LARGE MISSILE IMPACT

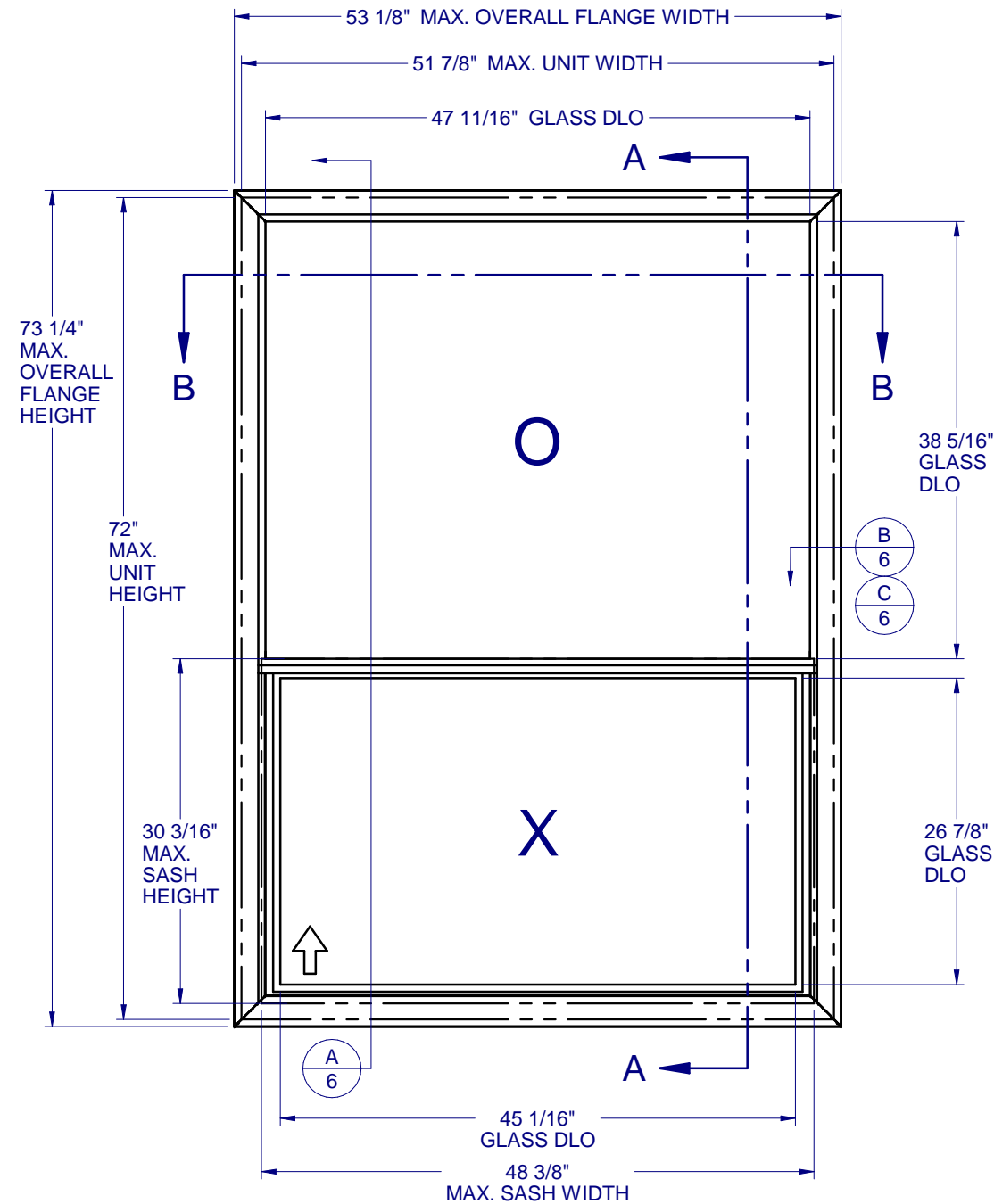

GENERAL NOTES:

1. THE PRODUCT SHOWN HEREIN IS DESIGNED AND MANUFACTURED TO COMPLY WITH THE FLORIDA BUILDING CODE (FBC), CURRENT EDITION INCLUDING THE HIGH VELOCITY HURRICANE ZONE (HVHZ) AND IS RATED FOR WIND ZONE 4 MISSILE LEVEL D IMPACT USE AS DEFINED IN ASTM E 1996 PER THE FBC.
2. GLAZING OPTIONS: (SEE SHEET 2)
3. CONFIGURATIONS: "O/X".
4. DESIGN PRESSURE RATING:
 - NEGATIVE DESIGN LOADS BASED ON, TESTED PRESSURE AND GLASS TABLES ASTM E-1300-04e01/09.
 - POSITIVE DESIGN LOADS BASED ON, TESTED PRESSURE, WATER INFILTRATION TEST PRESSURE AND GLASS TABLES ASTM E-1300-04e01/09.
5. ANCHORAGE: THE 33 1/3% STRESS INCREASE HAS NOT BEEN USED IN THE DESIGN OF THIS PRODUCT. SEE SHEET 6 FOR ANCHOR DETAILS. WINDLOAD DURATION FACTOR Cd=1.6 WAS USED FOR WOOD ANCHOR CALCULATIONS.
6. PRODUCT APPROVED FOR IMPACT RESISTANCE. SHUTTERS ARE NOT REQUIRED.
7. ALL FRAMES AND VENTS FULLY WELDED. SMALL JOINT SEAM SEALANT USED AT FIXED MEETING RAIL AND JAMB.
8. SERIES / MODEL DESIGNATION SH-8100.
9. THE DESIGNATION X AND O STAND FOR THE FOLLOWING:
X = OPERABLE SASH, O = FIXED SASH
10. SECTION CALLOUTS APPLY TO ALL ELEVATIONS IN A SIMILAR LOCATION.
11. EXTERNAL WEEP SLOT = 1/4" x 1-1/4" LOCATED 4" FROM BOTH ENDS.



8100 PVC SINGLE HUNG IMPACT

PROPRIETARY AND CONFIDENTIAL
THE INFORMATION CONTAINED IN THIS DRAWING IS THE SOLE PROPERTY OF CUSTOM WINDOW SYSTEMS, INC. ANY REPRODUCTION IN PART OR AS A WHOLE WITHOUT THE WRITTEN PERMISSION OF CUSTOM WINDOW SYSTEMS, INC IS PROHIBITED.

FLORIDA APPROVAL NO.:
17647



9/13/2023

LUCAS A. TURNER, P.E.
FL PE # 58201
Turner Engineering & Consulting, Inc.
2428 Old Natchez Trc Trl
Camden, TN 38320
PH. 941-380-1574

SHEET DESCRIPTION:
GENERAL NOTES AND ELEVATIONS

DRAWN BY: MCS	DATE: 8/22/2023
DWG #: CWS-882	REV.: F
SCALE: 1:15	SHEET 1 OF 6

TABLE OF CONTENTS

GENERAL NOTES & ELEVATIONS.....	1
GLAZING DETAILS.....	2
SECTION VIEWS.....	3
BOM & EXTRUSIONS.....	4
ANCHOR SCHEDULE & NOTES.....	5
INSTALLATION DETAILS.....	6

MAX. UNIT SIZE	DESIGN PRESSURE RATING	IMPACT RATING
51-7/8" x 72"	+/- 70 PSF	LARGE MISSILE IMPACT



1900 SW 44TH AVE.
 Ocala, Florida 34474
 WWW.CWS.CC

**8100 PVC
 SINGLE HUNG
 IMPACT**

PROPRIETARY AND CONFIDENTIAL
 THE INFORMATION CONTAINED IN
 THIS DRAWING IS THE SOLE
 PROPERTY OF CUSTOM WINDOW
 SYSTEMS, INC. ANY
 REPRODUCTION IN PART OR AS A
 WHOLE WITHOUT THE WRITTEN
 PERMISSION OF CUSTOM WINDOW
 SYSTEMS, INC IS PROHIBITED.

FLORIDA APPROVAL NO.:
 17647

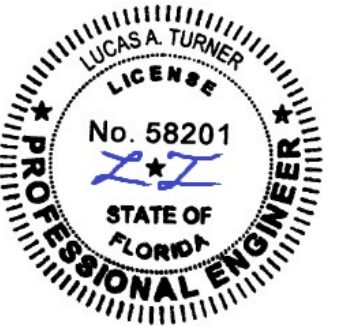

9/13/2023

LUCAS A. TURNER, P.E.
 FL PE # 58201
 Turner Engineering &
 Consulting, Inc.
 2428 Old Natchez Trc Trl
 Camden, TN 38320
 PH. 941-380-1574

SHEET DESCRIPTION:

GLAZING DETAILS

DRAWN BY: MCS	DATE: 8/22/2023
DWG #: CWS-882	REV.: F
SCALE: 1:1	SHEET 2 OF 6

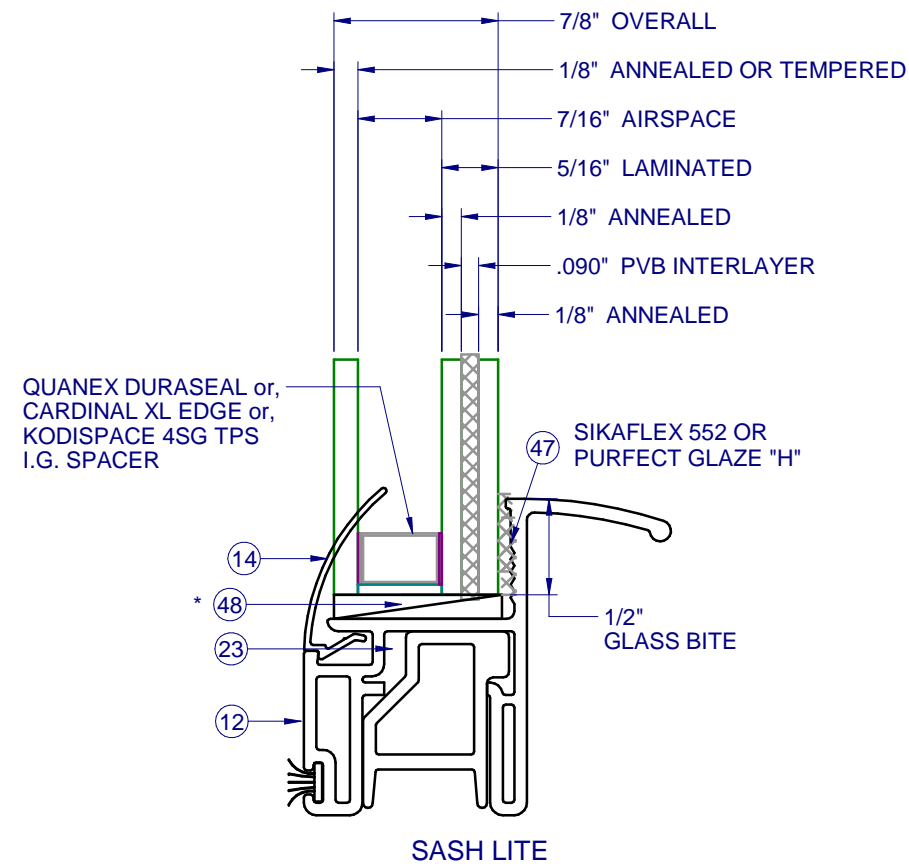
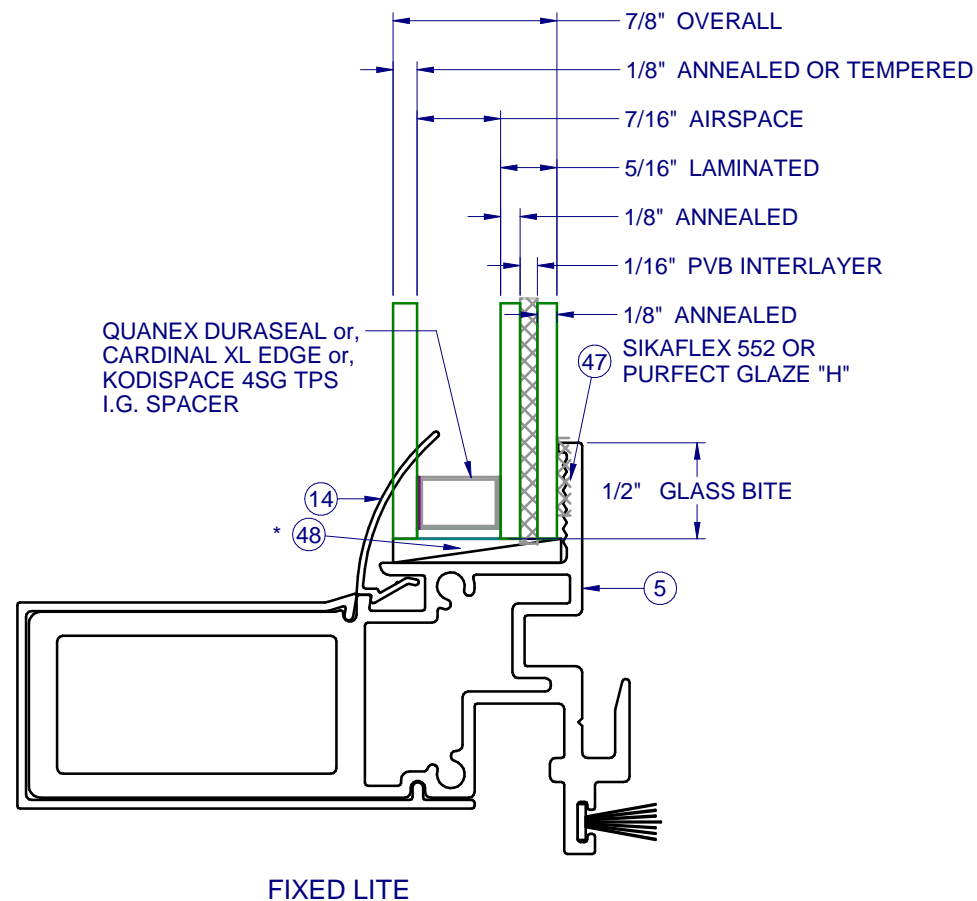

* SETTING BLOCKS PER FBC 2411.3.3.1



1900 SW 44TH AVE.
OCALA, FLORIDA 34474
WWW.CWS.CC

8100 PVC SINGLE HUNG IMPACT

PROPRIETARY AND CONFIDENTIAL
THE INFORMATION CONTAINED IN
THIS DRAWING IS THE SOLE
PROPERTY OF CUSTOM WINDOW
SYSTEMS, INC. ANY
REPRODUCTION IN PART OR AS A
WHOLE WITHOUT THE WRITTEN
PERMISSION OF CUSTOM WINDOW
SYSTEMS, INC IS PROHIBITED.

FLORIDA APPROVAL NO.:

17647



9/13/2023

LUCAS A. TURNER, P.E.
FL PE # 58201
Turner Engineering &
Consulting, Inc.
2428 Old Natchez Trc Trl
Camden, TN 38320
PH. 941-380-1574

SHEET DESCRIPTION:

SECTION VIEWS

DRAWN BY:	DATE:
MCS	8/22/2023
DWG #:	REV.:
CWS-882	F
SCALE:	SHEET
1:2	3 OF 6

INTERIOR

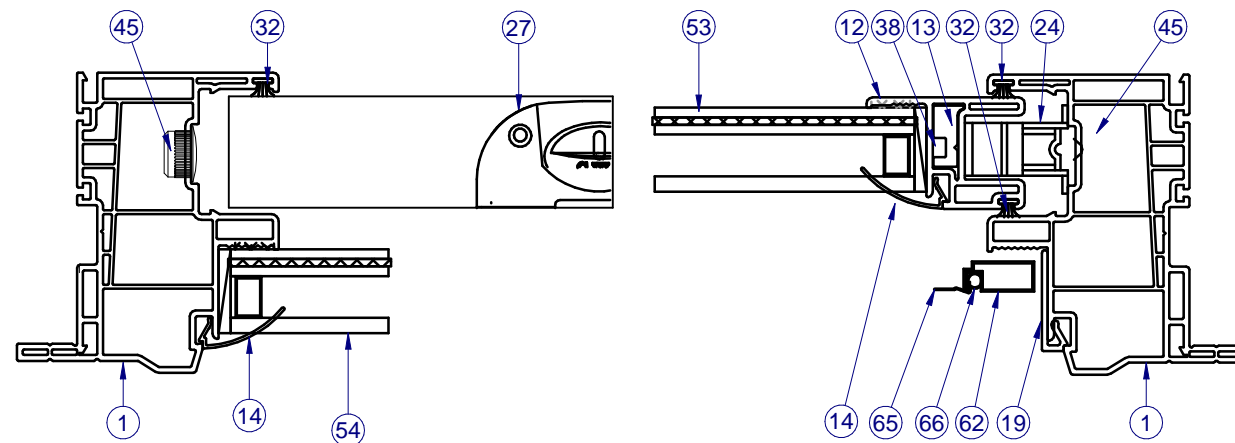

SECTION B-B

NOTE: LEFT SIDE SHOWS FIXED SECTION VIEW,
RIGHT SIDE SHOWS SASH SECTION VIEW.

INTERIOR

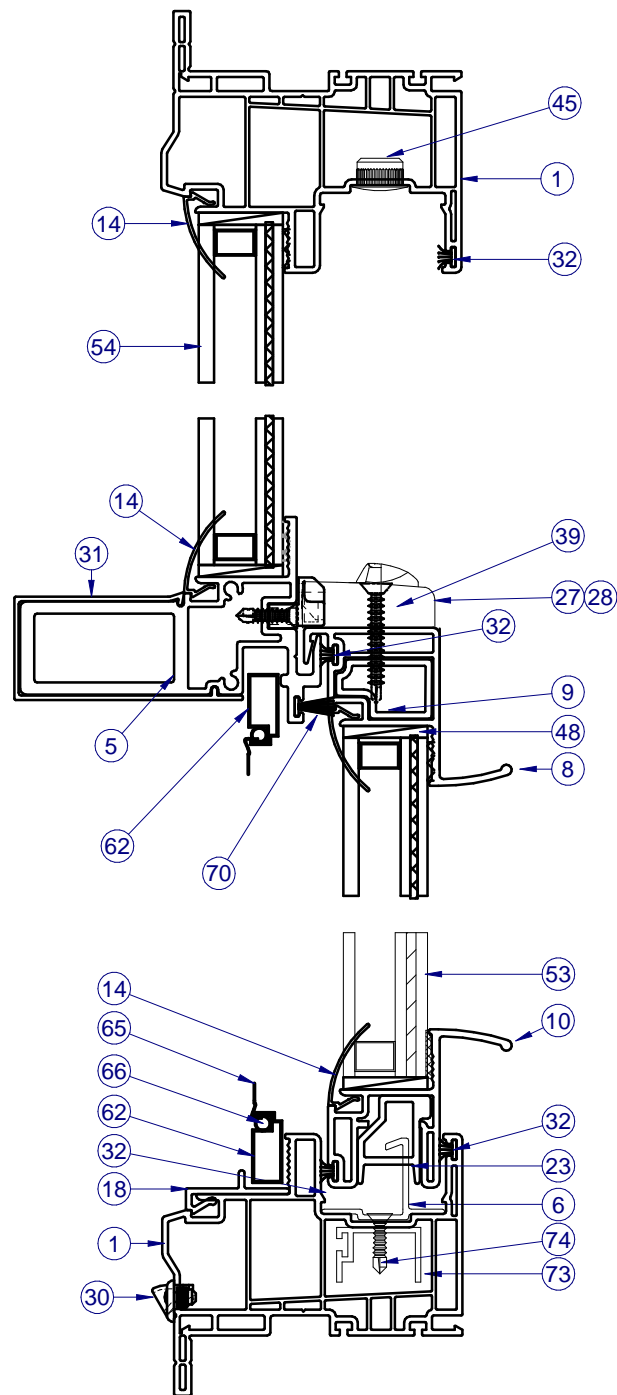

SECTION A-A

NOTE: ITEMS NOT SHOWN FOR CLARITY:
20, 25-26, 36-37, 44, 51-52, 55-56, 64, 67-68

PARTS LIST			
ITEM	PART #	DESCRIPTION	MATERIAL
1	H-6222	Main Frame, SH, w/Flg., PVC	Vinyl
5	H-2122	Heavy Duty, Meet. Rail, Fxd. Aluminum	Alum
6	S-1577	Impact Hook	Alum
8	H-6224	Sash Meet. Rail, PVC	Vinyl
9	H-2124	Reinf. Sash Meet. Rail	Alum
10	H-6223	Sash Bottom Rail, PVC	Vinyl
11	S-2129	Reinf. S.B.R./S.S.R	Alum
12	H-6225	Sash Side/Top/Bot. Rail	Vinyl
14	S-6237	Glz. Bd., 7/8"	Vinyl
18	S-6226	Scm. Adapt., w/Nib, PVC, Horiz.	Vinyl
19	S-6227	Scm. Adapt., PVC, Vert.	Vinyl
20	S-6025	Sash Stop / Filler, PVC, Vert.	Vinyl
23	H-2123	Reinforcement, SBR	Alum
24		SASH BALANCE	
25	P-4056	SASH CAM FOR PVC WINDOW	Plastic
26	P-3295	TAKE OUT CLIP	SS
27	P-3783	Lock, Impact, PVC	
28	P-4069	Keeper, Impact, PVC	Zamac
30	P-4479	WEEP HOLE COVER	Plastic
31	S-6229	HD Fixed Meeting Rail Cover	Vinyl
32	P-3305	Wstp., 0.270 x .187 High Density	
37	P-4638	#8 x 2-1/2 PH Mod. Truss, Type A, TEK 2	Steel
39	P-4051W	#8 x 1.250 Ph FH TEK, Wht.	Steel
40	P-3539	#8 x 3/4 Phillips Square SMS	Steel
44	P-3342	Seam Sealer, SM-5504	
45	P-5588	Cap Plug, 1/2" Hole	Nylon
47		Sikaflex 552 or Purfect Glaze "H"	
48	P-5612	Setting Block, .12 x 1 x 2	Rubber
53	Sash	SEE SHEET 2	GLASS
54	Fixed	SEE SHEET 2	GLASS
56		Spacer, See SHEET 2	
62	P-3218	Screen Frame	Alum
64	P-4754	SCREEN CORNER KEY	Plastic
65	P-4771	36" - BetterVue Insect Screen, 18x16	Fiberglass
66	P-5576	Screen Spline, .125" Black PE Ribbed	Vinyl
67	P-4755	Screen Corner Key W/ Safety Pull Tab	Alum
68	P-3195	SPRING, NO HOLE TENSION C-8400	SS
70	P-4959	Wstp., 0.420 x .187 High Density	
73	S-1112	Reinforcement, Impact Hooks	Alum
74	P-3541	#8 x 1/2" Quadrex PH TEK	Steel

LINE ITEMS NOT USED:
7, 13, 15-17, 21-22, 29, 33-36, 41-43, 46, 49-52, 55, 57-61, 69, 71-72

NOTE: ALL ALUMINUM EXTRUSIONS ARE 6063-T6 UNLESS OTHERWISE NOTED.

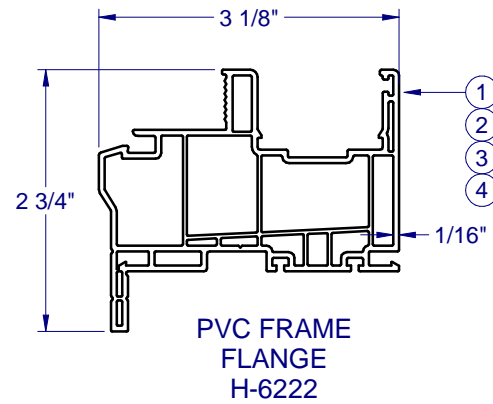

PVC FRAME FLANGE H-6222

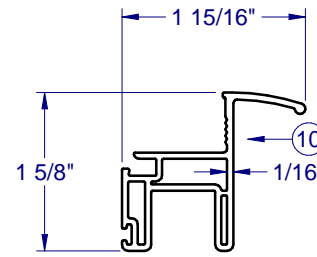

PVC SASH PULL RAIL/STILE H-6223

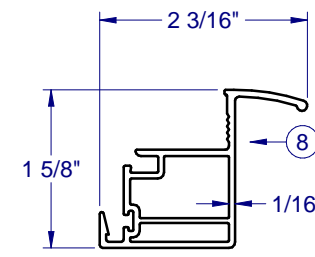

PVC SASH MTG RAIL H-6224

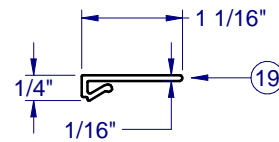

PVC SCREEN SUPPORT S-6227

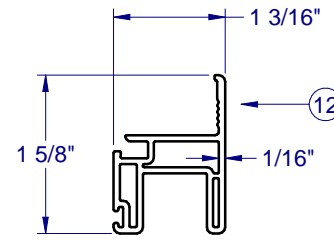

PVC SASH RAIL/STILE H-6225

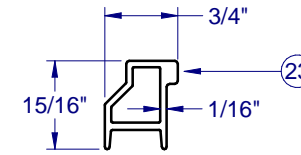

REINF. H-2123

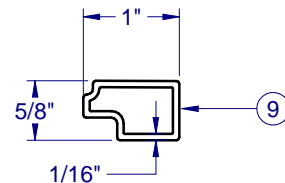

REINF. SASH MTG RAIL H-2124

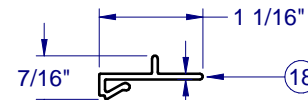

PVC SCREEN CATCH S-6226

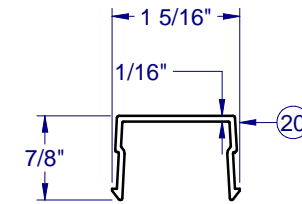

PVC SASH STOP S-6025

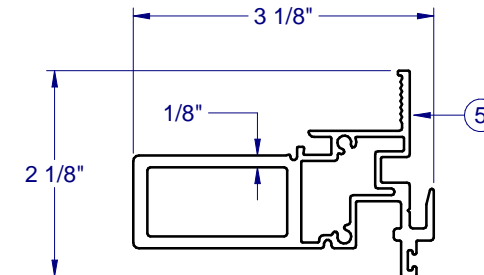

HD MTG RAIL H-2122

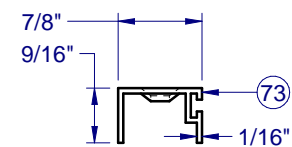

REINF. IMPACT HOOK S-1112

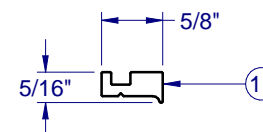

REINF. S-2129

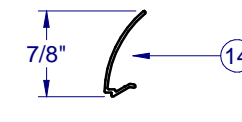

PVC GLAZING BEAD S-6237

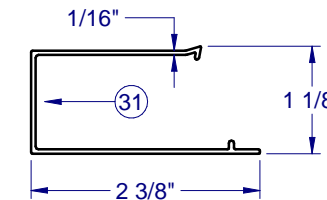

PVC HD MTG RAIL COVER S-6229

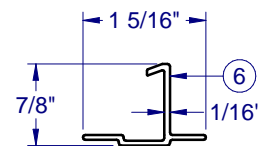

IMPACT HOOK S-1577

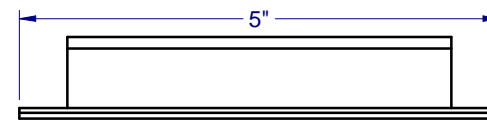

FRAME CORNER CONSTRUCTION

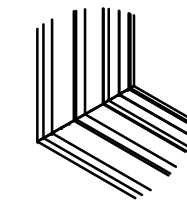

CORNER WELD (ALL SIDES) 1:8

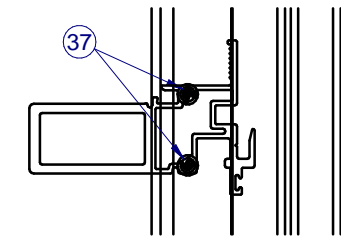

FIXED MEETING RAIL SCREWED TOGETHER WITH OUTERFRAME 1:8

1900 SW 44TH AVE.
OCALA, FLORIDA 34474
WWW.CWS.CC

8100 PVC SINGLE HUNG IMPACT

PROPRIETARY AND CONFIDENTIAL
THE INFORMATION CONTAINED IN THIS DRAWING IS THE SOLE PROPERTY OF CUSTOM WINDOW SYSTEMS, INC. ANY REPRODUCTION IN PART OR AS A WHOLE WITHOUT THE WRITTEN PERMISSION OF CUSTOM WINDOW SYSTEMS, INC IS PROHIBITED.

FLORIDA APPROVAL NO.:
17647

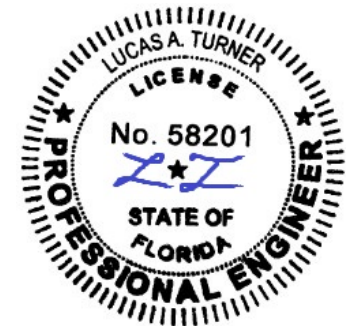

9/13/2023

LUCAS A. TURNER, P.E.
FL PE # 58201
Turner Engineering & Consulting, Inc.
2428 Old Natchez Trc Trl
Camden, TN 38320
PH. 941-380-1574

SHEET DESCRIPTION:

BOM AND EXTRUSIONS

DRAWN BY: MCS	DATE: 8/22/2023
DWG #: CWS-882	REV.: F
SCALE: 1:2	SHEET 4 OF 6

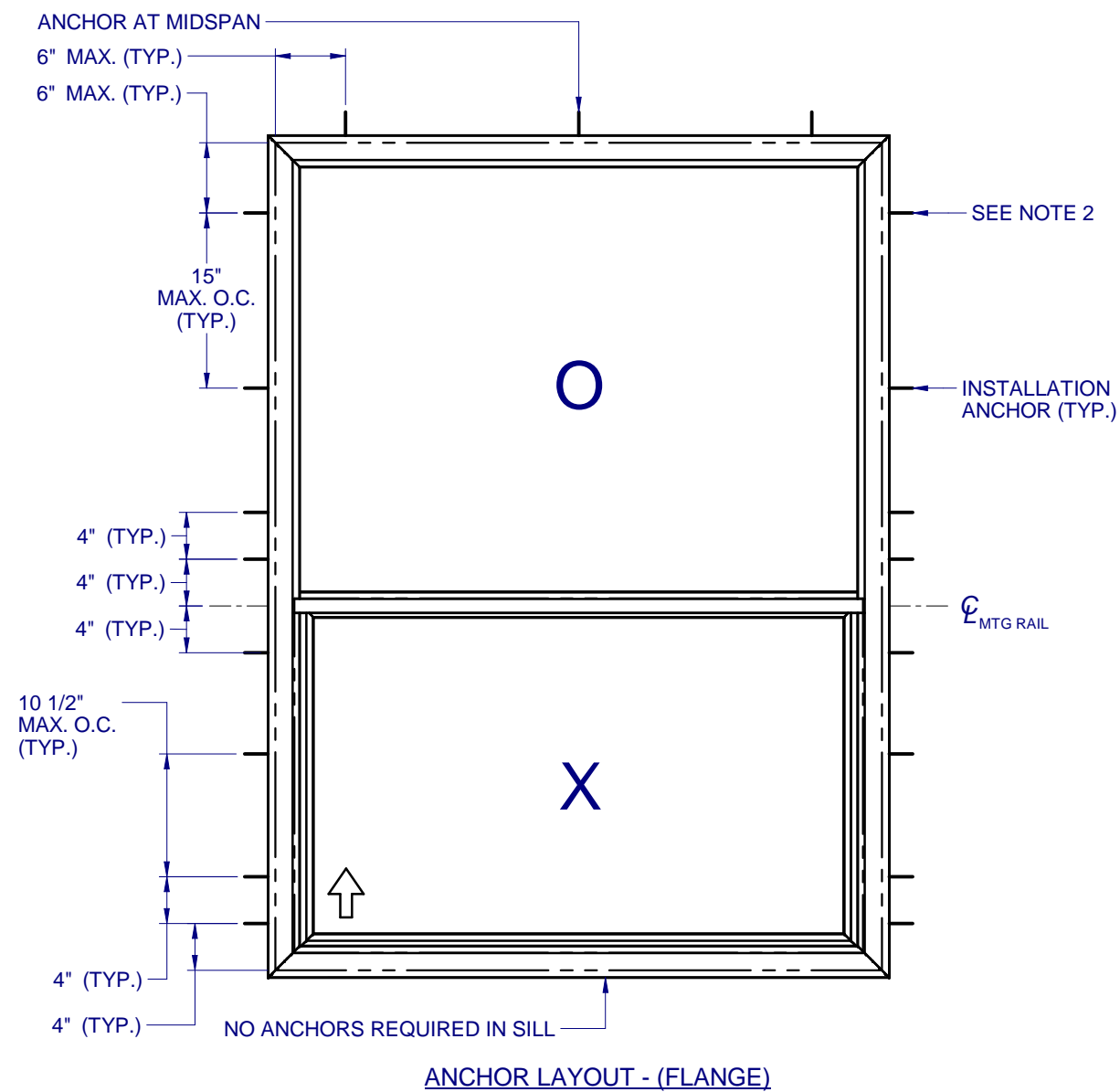

ANCHOR LAYOUT - (FLANGE)

NOTES:

1. INSTALL ONE ANCHOR AT EACH INSTALLATION LOCATION. NO ANCHORS REQUIRED IN SILL.
2. SHIM AS REQ AT EACH INSTALLATION ANCHOR USING LOAD BEARING SHIMS. MAX. ALLOWABLE SHIM STACK TO BE 1/4". USE SHIMS WHERE SPACE GREATER THAN 1/16" IS PRESENT. LOAD BEARING SHIMS SHALL BE CONSTRUCTED OF HIGH DENSITY PLASTIC OR BETTER. WOOD SHIMS ARE NOT ALLOWED.
3. ANCHOR TYPE, SIZE, SPACING AND EMBEDMENT SHALL BE AS SPECIFIED IN THESE DRAWINGS, SEE TABLE 1, SHEET 6.
4. ALL INSTALLATION ANCHORS MUST BE MADE OF OR PROTECTED WITH A CORROSION RESISTANT MATERIAL OR COATING. DISSIMILAR METALS OR MATERIALS IN CONTACT WITH PRESSURE TREATED WOOD MUST BE PROTECTED TO PREVENT REACTION.
5. INSTALLATION ANCHORS SHALL BE IN ACCORDANCE WITH ANCHOR MANUFACTURER'S INSTALLATION INSTRUCTIONS, AND ANCHORS SHALL NOT BE USED IN SUBSTRATES WITH STRENGTHS LESS THAN THE MINIMUM SPECIFIED IN TABLE 1, SHEET 6.
6. ANCHOR EMBEDMENT TO SUBSTRATE SHALL BE BEYOND WALL DRESSING OR STUCCO. FOR CONCRETE/CMU OPENINGS, EMBEDMENT SHALL BE BEYOND WOOD BUCKS, IF USED, INTO SUBSTRATE. INSTALLATIONS TO SOLID CONCRETE OR GROUT-FILLED CMU MAY INCLUDE BUT DO NOT REQUIRE 1X WOOD BUCKS BETWEEN THE PRODUCT AND THE SUBSTRATE. INSTALLATIONS TO HOLLOW CMU REQUIRE THE USE OF 1X BUCKS BETWEEN THE PRODUCT AND SUBSTRATE.
7. A MINIMUM CENTER-TO-CENTER SPACING SHALL BE MAINTAINED BETWEEN ALL FASTENERS: 3" FOR MASONRY, 1" FOR WOOD AND METAL.
8. WOOD OR MASONRY OPENINGS, BUCKS AND BUCK FASTENERS SHALL BE PROPERLY DESIGNED BY THE ARCHITECT OR ENGINEER OF RECORD AND INSTALLED TO TRANSFER WIND LOADS TO THE STRUCTURE. SUBSTRATES SHALL MEET THE MINIMUM STRENGTH REQUIREMENTS AS SHOWN IN TABLE 1, SHEET 6. CONCRETE AND MASONRY SUBSTRATES MAY NOT BE CRACKED.
9. SEALING AND FLASHING STRATEGIES FOR OVERALL WATER RESISTANCE OF INSTALLATION SHALL BE DONE BY OTHERS FOLLOWING THE CURRENT VERSION OF THE REFERENCE DOCUMENTS: FMA/AAMA 100(FIN WINDOWS), FMA/AAMA 200(FLANGE WINDOWS), FMA/WDMA 250(BOX WINDOWS), FMA/AAMA/WDMA 300(EXTERIOR DOORS)

**8100 PVC
SINGLE HUNG
IMPACT**

PROPRIETARY AND CONFIDENTIAL
THE INFORMATION CONTAINED IN THIS DRAWING IS THE SOLE PROPERTY OF CUSTOM WINDOW SYSTEMS, INC. ANY REPRODUCTION IN PART OR AS A WHOLE WITHOUT THE WRITTEN PERMISSION OF CUSTOM WINDOW SYSTEMS, INC IS PROHIBITED.

FLORIDA APPROVAL NO.:
17647



9/13/2023

LUCAS A. TURNER, P.E.
FL PE # 58201
Turner Engineering & Consulting, Inc.
2428 Old Natchez Trc Trl
Camden, TN 38320
PH. 941-380-1574

SHEET DESCRIPTION:
ANCHOR SCHEDULE AND NOTES

DRAWN BY: MCS	DATE: 8/22/2023
DWG #: CWS-882	REV.: F
SCALE: 1:15	SHEET 5 OF 6



1900 SW 44TH AVE.
OCALA, FLORIDA 34474
WWW.CWS.CC

8100 PVC SINGLE HUNG IMPACT

PROPRIETARY AND CONFIDENTIAL
THE INFORMATION CONTAINED IN THIS DRAWING IS THE SOLE PROPERTY OF CUSTOM WINDOW SYSTEMS, INC. ANY REPRODUCTION IN PART OR AS A WHOLE WITHOUT THE WRITTEN PERMISSION OF CUSTOM WINDOW SYSTEMS, INC IS PROHIBITED.

FLORIDA APPROVAL NO.:

17647



9/13/2023

LUCAS A. TURNER, P.E.
FL PE # 58201
Turner Engineering & Consulting, Inc.
2428 Old Natchez Trc Trl
Camden, TN 38320
PH. 941-380-1574

SHEET DESCRIPTION:

INSTALLATION DETAILS

DRAWN BY:	DATE:
MCS	8/22/2023
DWG #:	REV.:
CWS-882	F
SCALE:	SHEET
1:2	6 OF 6

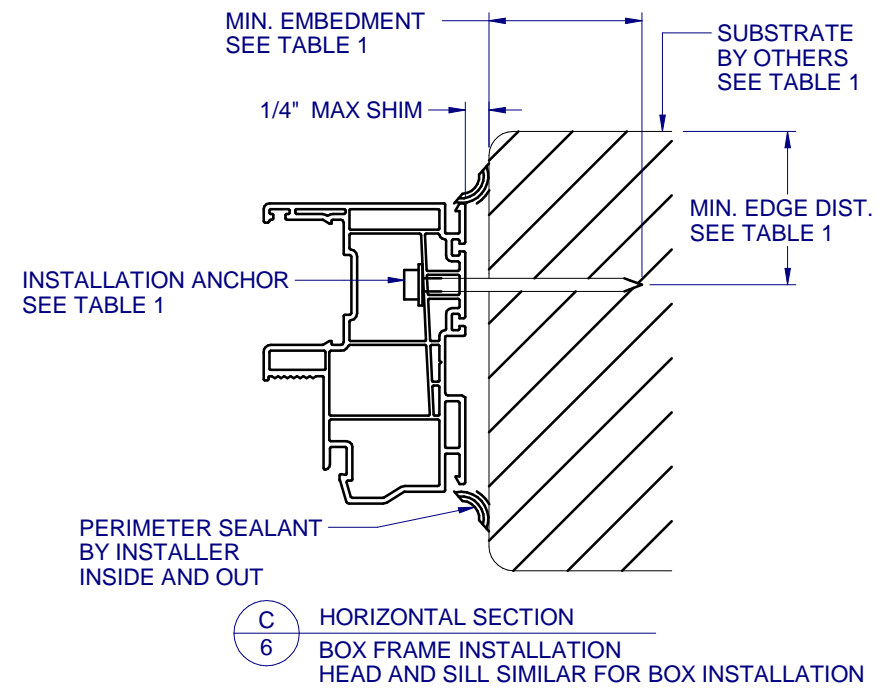
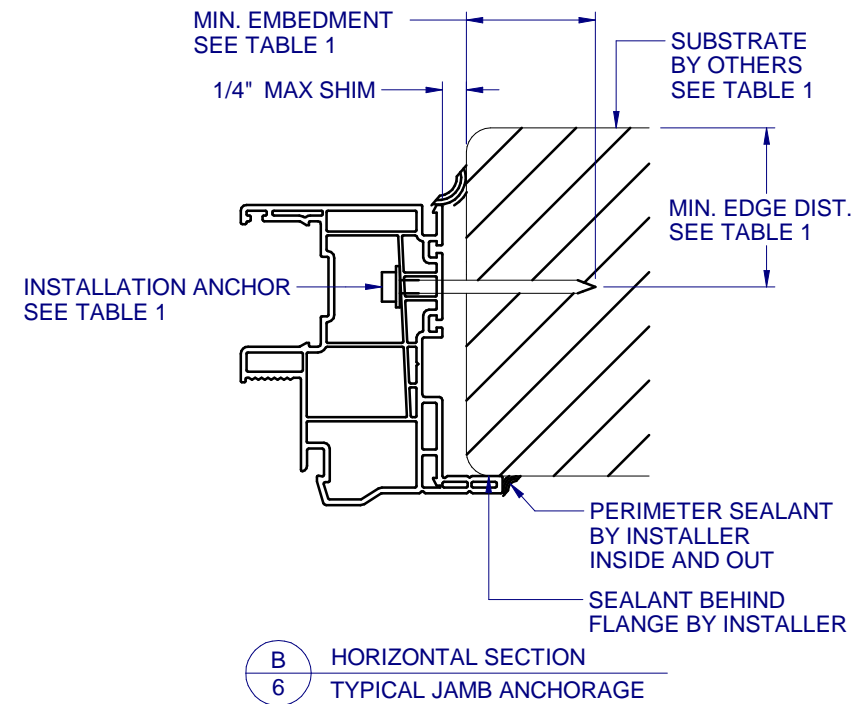
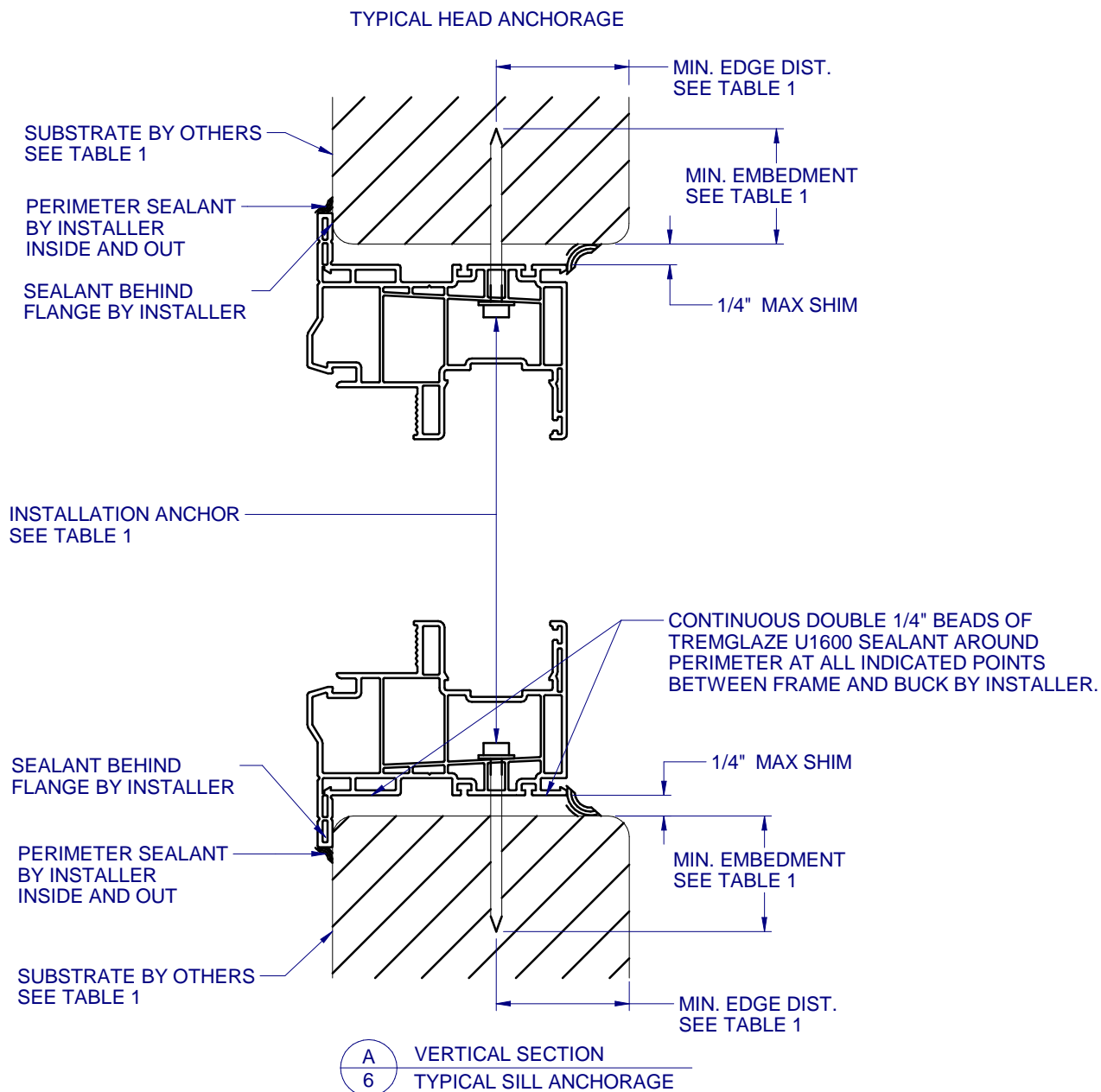

FLANGE REMOVAL NOTE: PARTIALLY OR FULLY REMOVING THE FLANGE, UP TO AND INCLUDING A BOX-FRAME APPLICATION IS ACCEPTABLE PROVIDED:

- MIN. 1/4" FILLET OF CONSTRUCTION-GRADE ADHESIVE CAULK IS APPLIED INSIDE AND OUT, FULL PERIMETER, BY INSTALLER.
- PRODUCT ANCHORAGE IS IN ACCORDANCE WITH REQUIREMENTS AS SHOWN FOR FLANGE WINDOWS.

TABLE 1: APPROVED INSTALLATION FASTENERS

SUBSTRATE TYPE	ANCHOR TYPE	MIN. EMBEDMENT	MIN. EDGE DIST.
CONCRETE (2.0 KSI MIN.)	3/16" ITW TAPCON	1-1/2"	1-1/8"
HOLLOW OR GROUT-FILLED CMU (117 PCF MIN.)	3/16" ITW TAPCON	1"	2"
CONCRETE (3.05 KSI MIN.)	3/16" DEWALT ULTRACON+	1-3/4"	1"
HOLLOW OR GROUT-FILLED CMU (ASTM C-90)	3/16" DEWALT ULTRACON+	1-1/4"	2-1/2"
2X MIN. SOUTHERN PINE (G=0.55)	3/16" ITW TAPCON OR DEWALT ULTRACON+	1-3/8"	7/8"
2X MIN. SOUTHERN PINE (G=0.55)	#10 WOOD SCREW	1-3/8"	7/8"
16 GAUGE (0.060") MIN. STEEL STUD (33 KSI YIELD MIN)	#10-16 HILTI KWIK-FLEX OR ITW TEKS SELF-DRILLING SCREW	FULL THREAD THRU 0.060"	7/16"
1/8" ALUM. (6063-T5 MIN.) OR 1/8" STEEL (33 KSI MIN.)	#10 GRADE 5 SELF-TAPPING / DRILLING SCREW	FULL THREAD THRU 0.125"	7/16"