



CLIP & CAULK™ INSTALLATION

Clip & Caulk

A Rout and Return “look” without the expense. No prefabrication is required. Cut panels on-site with standard carpentry tools. Color-matched panels, caulk, and flashing are available.

Before You Start	1
Preparing the Wall	
Installation Over Plywood Sheathing	2 - 3
Installation Over Plywood with Building Wrap	4 - 5
Installation Over Gypsum with or without Building Wrap	6 - 7
Installation Over Hat Channels	8 - 9
Edge-Sealing and Venting the Panels	10 - 12
Installing the Panels	12 - 13
Final Joint Caulking	13 - 14
Essential Equipment and Supplies	15
Additional Accessories	16
Panel Maintenance	Inside Back Cover

Failure to follow these installation instructions and guidelines will void your warranty. For technical and installation support, call 800.523.2347.

Panels with Metallic Paint Finishes:

The protective masking on the face of each panel should be left in place until work is complete on any given area of an installation. However, to help ensure good color uniformity, periodically remove the masking from half of a panel (peel masking upward from the bottom of the panel) to check for color, scratches, and dents.

On panels with metallic finishes, a good color match is much more difficult to achieve. In this case, two adjoining panels should be periodically checked by removing the masking from half of two panels as the installation progresses. The masking should then be taped back over the panel to protect it.

Should any defects be found, stop work immediately and call Laminators for assistance.

When installing panels with metallic finishes, it is very important that the directional arrows on the panel masking are oriented in the same direction.

Color variation is a characteristic of Aluminum composite panels with metallic paint finishes. Laminators Incorporated DOES NOT warrant a color match for these panels.

Substrate & Framing

Prior to installation, the installer **MUST** verify that the framing and substrate are in compliance with all architects' specifications.

Inspect BOTH primary and secondary wall framing to verify that all girts, angles, channels, studs, and sheathing and other structural panel support members and anchorage have been installed within the following tolerances:

1/4" in any 20' length vertically or horizontally

1/2" in any building elevation

Inspect sheathing to verify that sheathing joints are supported by framing and that installation is within flatness tolerances. These surfaces must be even, smooth, sound, clean, and dry. If the substrate or framing is not within architectural specifications, the installer must submit a written report to the General Contractor listing conditions that are detrimental to the installation of panels. Do NOT proceed with installation until unsatisfactory conditions have been corrected.

Summary of Installer Responsibility

The Panel Installer assumes total responsibility for all components of the panel installation including, but not limited to, attachment to sub-construction, panel-to-panel joints, joints between panels and dissimilar material, and the joint seal associated with panel system.

Installation Supplies & Accessories

See page 15 to be sure you are using materials that have been tested and approved by Laminators for use with Omega-Lite panels. Inventory all materials and accessories to ensure that all materials are available on-site. Call Tech Support if you need additional recommendations.

Receiving & Storage

Examination: Upon receipt of materials, perform a thorough examination to identify any damage that may have occurred during shipping. Any damage must be noted on the bill of lading at the time of receipt.

Storage: Panels are to be stored horizontally on pallets with a positive slope for drainage of water and should be covered with watertight and ventilated materials. *Standing water will damage panel finish.*

No more than 1500 pounds should be stacked on one pallet. Depending on panel size, this should be fewer than 50 panels at 30 pounds per panel and less than 2-1/2' high. Do not stack other materials on or in contact with panels to prevent staining, denting, or other damage. Storage temperature must not exceed 120°F (49°C).

Laminators' warranty does not cover water damage caused by improper storage or installation. Inspect panels on delivery, then store them on skids 8" above the ground. Place a breathable cover over them and store them in a ventilated space under roof.

If wet panels are discovered, uncrate them and dry them with towels to prevent wood rotting, paint attaining, or aluminum corrosion.

Panel Handling

Use clean work gloves to avoid hand injury from any sharp edges and to prevent smudging of the prefinished surfaces. Although panels are shipped with protective masking, always lift one panel completely off the next to prevent scratches. Do not slide one panel across another.

Protect panels from construction hazards. Good construction practice provides for panel protection and cleaning in the contract documents. Normally these are the general contractor's responsibility. Temporary protection may be required if welding, cutting, sandblasting, or other potentially damaging construction activities are scheduled nearby.

Cutting the Panels

Omega-Lite panels are designed to be cut to size on the job site. Even if the panels have been received cut to size, it may be necessary to do some minor trimming to account for areas of an elevation that may be out of square. To cut Omega-Lite panels, use a circular saw with a sharp, carbide-tipped blade (40-tooth minimum). Do not remove the protective masking from the panel face. After cutting, use a screwdriver or deburring tool to remove burrs or sharp edges from the panels. If you cut the panels, they must be edge-sealed and back-vented immediately. See page 10 for more details.

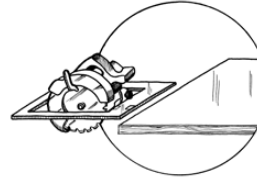

**Carbide-tipped
blade (40 tooth min.)
recommended**

**Safety tip: Wear safety glasses when cutting!
Wear gloves when handling cut edges!**

Ventilation is Important

The wood or exterior gypsum board of the substrate must be protected and ventilated. Trapped moisture can cause major damage in a short time. When mounting over exterior gypsum or masonry, use steel strapping or hat channels to separate panels from the structure for good air circulation.

Flashing

Laminators can supply flashing materials made from aluminum sheet painted to match the adjacent panel system or surface.

Use proper flashing technique when installing flashing with panels.

Complete CAD details and product specifications can be downloaded from our website **LaminatorsInc.com**

Installation Over Plywood Sheathing

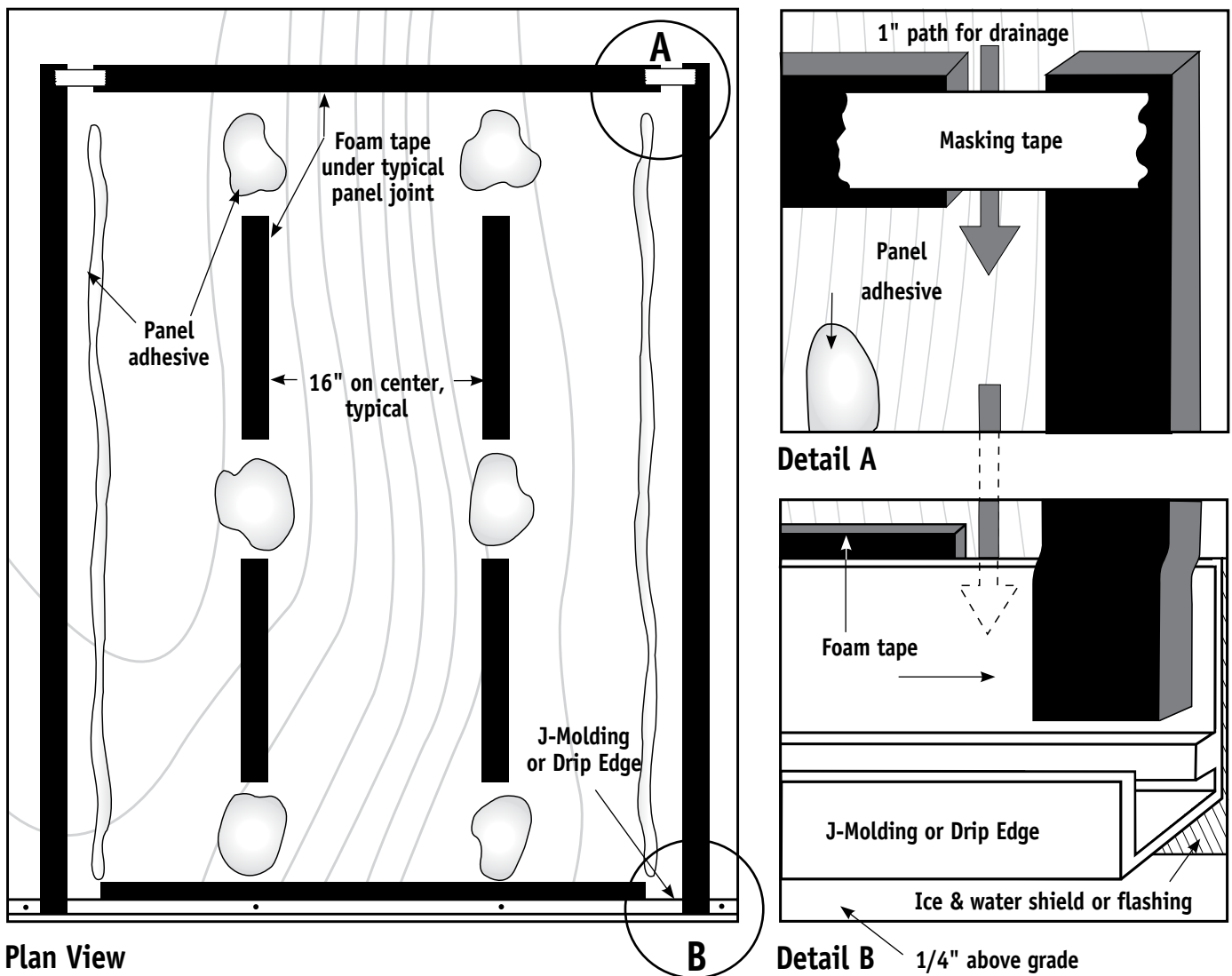

This installation process is the basis for mounting panels over a variety of substrates. You should read and understand this process before attempting to mount panels over other substrates such as plywood covered with building paper, exterior gypsum with or without building paper, etc.

In all cases, the same elements must be present:

- 1) A structural surface, such as plywood, that will hold mechanical fasteners, such as screws.
- 2) A surface that can be bonded to with panel adhesive.

If these two elements are not present, additional steps must be taken to provide them. Exterior grade gypsum, building wrap, or block walls are examples of substrates that will require additional preparation before panels can be mounted. These surfaces are covered in this manual.

The main drawing (*upper left*) depicts the layout for one panel at ground level. J-Molding is shown: either J- or drip edge molding can be used here. (*See 1-Piece, Tight-Fit Molding Guide for complete installation instructions for J- or Drip Edge Moldings.*) The detail drawings (**Detail A & B**) show close-up details from the main drawing. The instructions on the opposing page explain this process and the purpose of each element shown in the above drawings.

Note: To guard against water penetration, Laminators recommends that all these installation systems include a vapor permeable, air and water moisture barrier (appropriate for the climate and wall construction) installed on the substrate behind the metal wall panels.

Installation Over Plywood Sheathing

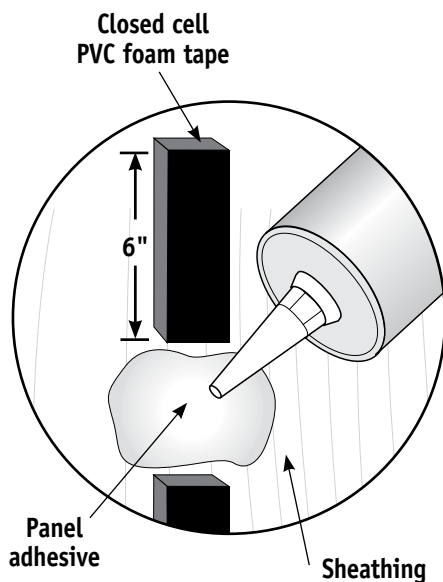
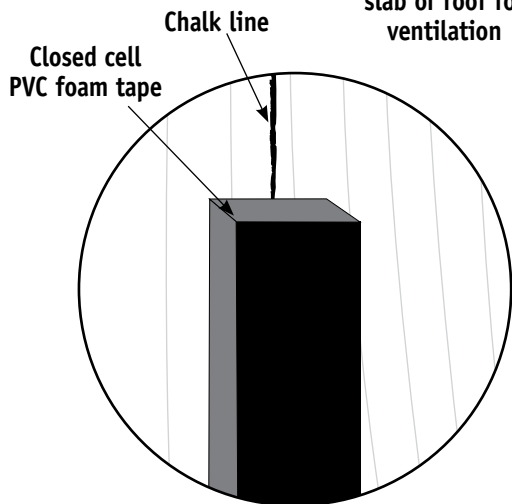
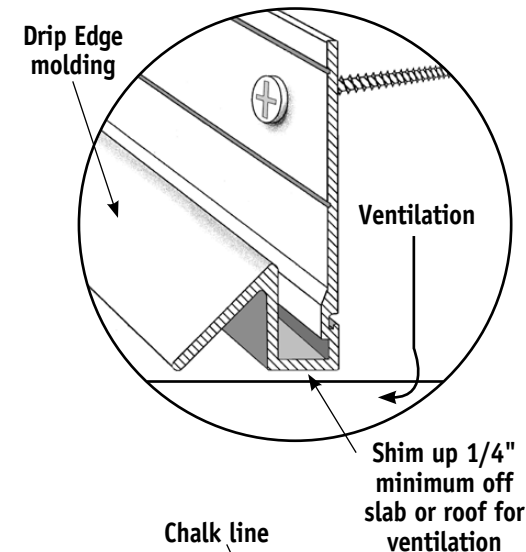

Step 1: Install J-Molding or Drip Edge

Start by installing drip edge moldings along the bottom edge of the wall for the panels to rest in. Keeping the molding 1/4" min. above ground level, use galvanized drywall screws to attach the molding to the plywood every 12" to 16" on-center. Use an ice and water shield or flashing to prevent water from getting to the plywood at ground level. This is shown in **Detail B** on the previous page.

See manufacturer's instructions for the proper use of ice and water shield.

Step 2: Apply closed cell PVC foam tape

Using chalk lines, mark locations where caulk joints between panels will occur. The main drawing on the previous page shows the locations of three caulk joints. Two of them are vertical joints, one to the extreme left, and one to the extreme right. A horizontal joint is shown at the top of the drawing. These joints are indicated by the foam tape. A 1" gap is shown where the horizontal joint intersects the vertical joint (**Detail A**). This gap provides a path for drainage and the masking tape "bridge" provides a backing for the caulk joint.

There are two reasons for installing foam tape behind joints. It prevents three-way caulk adhesion which would cause the caulk joint to fail almost immediately. It also acts as a primary seal against water.

Note: *It is important to keep the liner on the foam tape as it is applied to avoid stretching or inaccurate placement.*

Note: *For placement of foam tape: determine the middle of the joint and snap a line. Measure 1" away from center of joint and place your tape. Snap a new line in the center of the tape. To determine placement of panels at the joint, measure 1/4" on either side of the new center line on the foam tape.*

Step 3: Apply panel adhesive

Apply closed cell PVC foam tape behind the panel every 16" O.C. as shown in the main drawing on page 2. These strips of foam tape act as a shim and help to keep everything on the correct plane. Apply generous 3" dabs and 3/8" beads of panel adhesive as shown in the main drawing on page 2.

Many panel adhesives have a high solvent content that evaporates as it cures. This causes the adhesive to lose volume and shrink. Applying panel adhesive next to the foam tape will prevent the panels from being drawn in towards the plywood, ensuring that the panels will maintain a flat appearance.

Installation Over Plywood Sheathing with Building Wrap

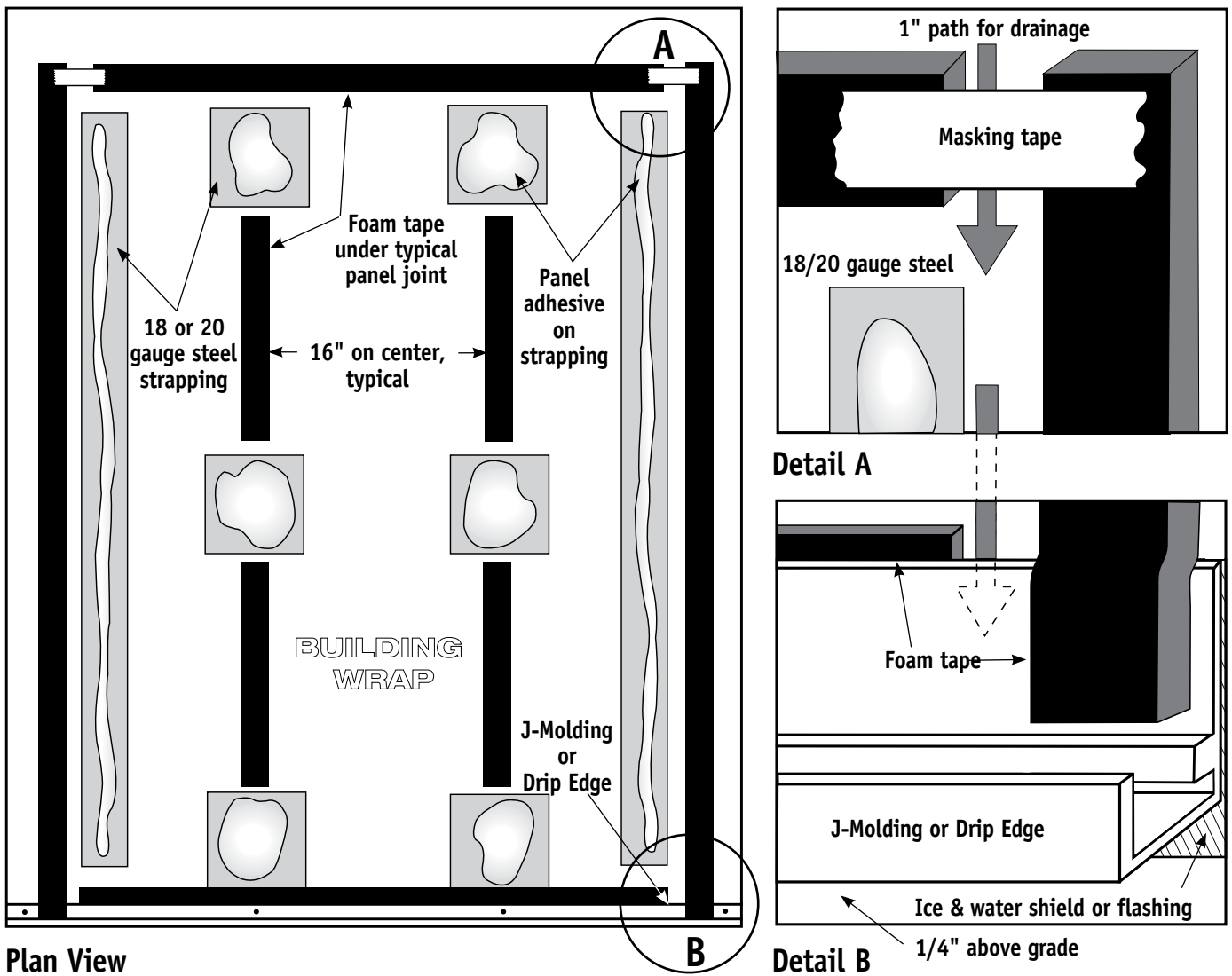

In cases where panels are to be installed over plywood sheathing that is covered with building wrap, the following process must be used. Remember, while the plywood sheathing is structural, building wrap is not.

In these situations, steel strapping needs to be installed so that the panels can be glued to a structural surface.

The main drawing (*upper left*) and two detail drawings (**Detail A & B**) show a wall layout for one panel at ground level.

Notice that 18 or 20 gauge steel strapping has been attached through the building paper to the plywood using galvanized drywall screws.

This gives the panel a surface to which it can bond. The instructions on the opposing page explain this process and the purpose of each element shown in the above drawings.

Installation Over Plywood Sheathing with Building Wrap

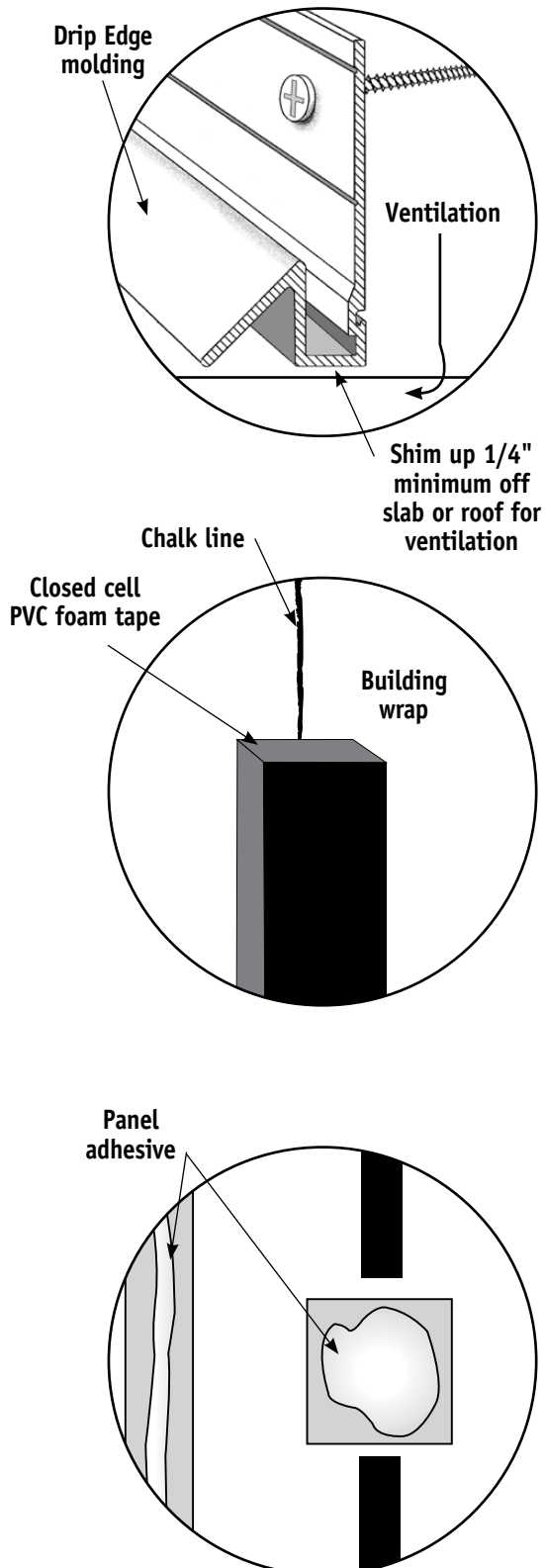

Step 1: Install J-Molding or Drip Edge

Start by installing drip edge moldings along the bottom edge of the wall for the panels to rest in. Keeping the molding 1/4" above ground level, use galvanized drywall screws to attach the molding to the plywood every 12" to 16" on-center. Use an ice and water shield or flashing to prevent water from getting to the plywood at ground level. This is shown in **Detail B** on the previous page.

See manufacturer's instructions for the proper use of ice and water shield.

Step 2: Apply closed cell PVC foam tape

Using a chalk line, mark locations where caulk joints between panels will occur. The main drawing on the previous page shows the locations of three caulk joints. Two of them are vertical joints, one to the extreme left, and one to the extreme right. A horizontal joint is shown at the top of the drawing. These joints are indicated by the foam tape. A 1" gap is shown where the horizontal joint intersects the vertical joint (**Detail A**). This gap provides a path for drainage, and the masking tape "bridge" provides a backing for the caulk joint.

There are two reasons for installing foam tape behind joints. It prevents three-way caulk adhesion which would cause the caulk joint to fail almost immediately. It also acts as a primary seal against water.

Note: *It is important to keep the liner on the foam tape as it is applied to avoid stretching or inaccurate placement.*

Note: *For placement of foam tape: determine the middle of the joint and snap a line. Measure 1" away from center of joint and place your tape. Snap a new line in the center of the tape. To determine placement of panels at the joint, measure 1/4" on either side of the new center line on the foam tape.*

Step 3: Apply panel adhesive

Apply closed cell PVC foam tape behind the panel every 16" O.C. as shown in the main drawing on the opposite page. These strips of foam tape act as a shim and help to keep everything on the correct plane. Apply generous 3" dabs and 3/8" thick beads of panel adhesive to steel straps. Strapping squares should be at least 3" x 3" and straps should be 3" wide x the panel height. Straps should be screwed down every 16"-24" O.C.

Many panel adhesives have a high solvent content that evaporates as it cures. This causes the adhesive to lose volume and shrink. Applying panel adhesive next to the foam tape will prevent the panels from being drawn in towards the plywood, ensuring that the panels will maintain a flat appearance.

Installation Over Gypsum (With or without building wrap)

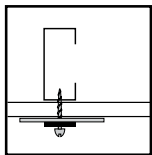
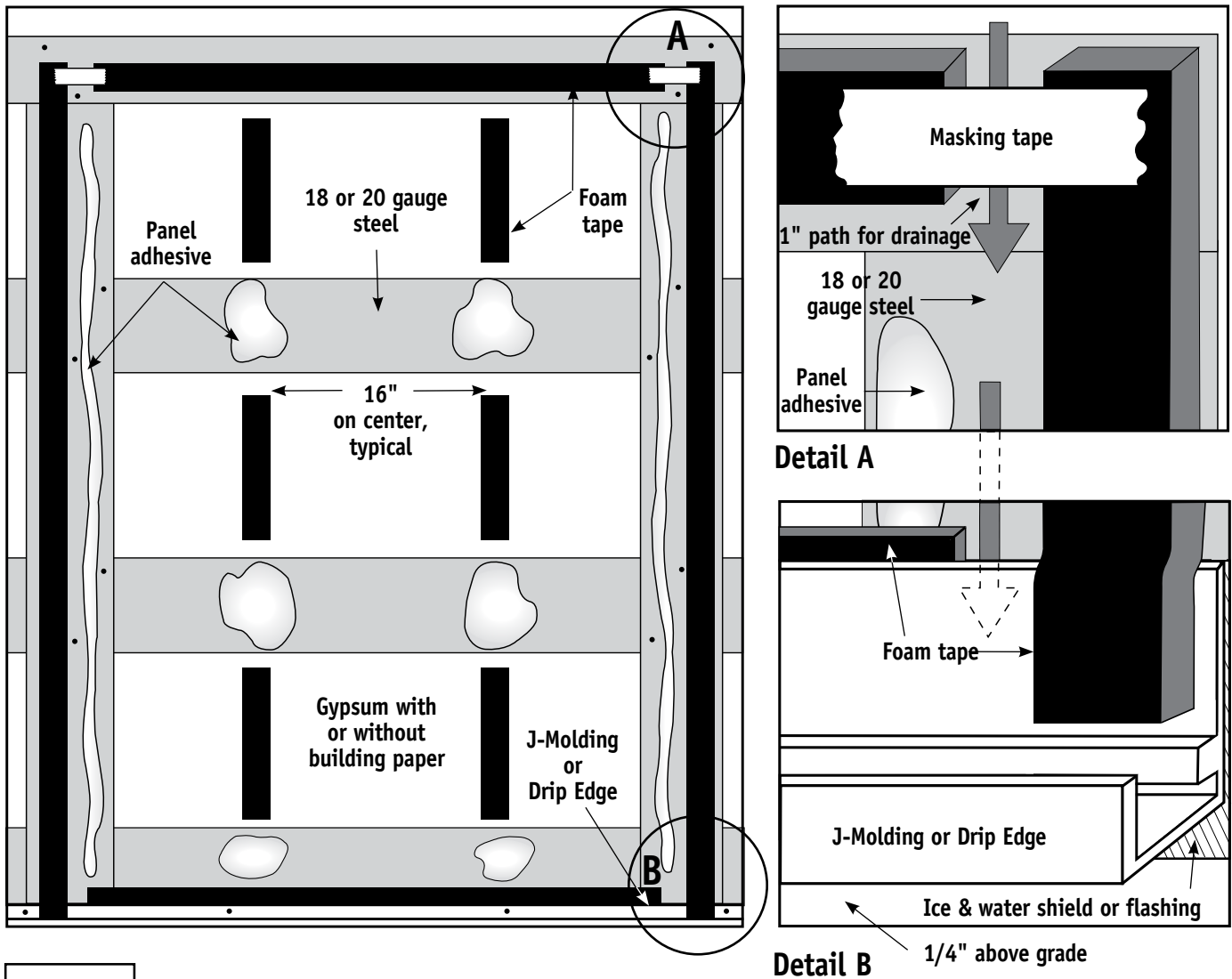

Section View

When installing panels over exterior grade gypsum, with or without building wrap, remember that neither exterior grade gypsum nor building wrap are structural.

For these installations, metal strapping must also be used so the panels can be anchored directly to the studs behind the gypsum.

For proper installation, 18 or 20 gauge steel strap must be used to create a surface that will both hold a screw and accept panel adhesive. Continuous pieces of 3"-wide steel strap must be used anywhere there is a joint between two panels, either vertically or horizontally.

Where steel strapping overlaps, they must be attached with low-profile screws. Minimum 2 screws per overlap. Strapping must also be used anywhere foam tape and panel adhesive are used. When steel strapping crosses the studs, the screws must pass through the steel strap and the exterior grade gypsum, and attach to the stud wall.

Installation Over Gypsum (With or without building wrap)

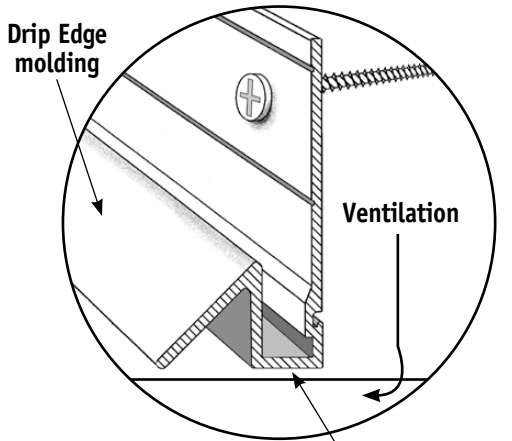

Step 1: Install J-Molding or Drip Edge

Start by installing drip edge moldings along the bottom edge of the wall for the panels to rest in. Keeping the molding 1/4" min. above ground level, use galvanized drywall screws to attach the molding to the plywood every 12" to 16" O.C. Use an ice and water shield or flashing to prevent water from getting to the plywood at ground level. This is shown in **Detail B** on the previous page.

See manufacturer's instructions for the proper use of ice and water shield.

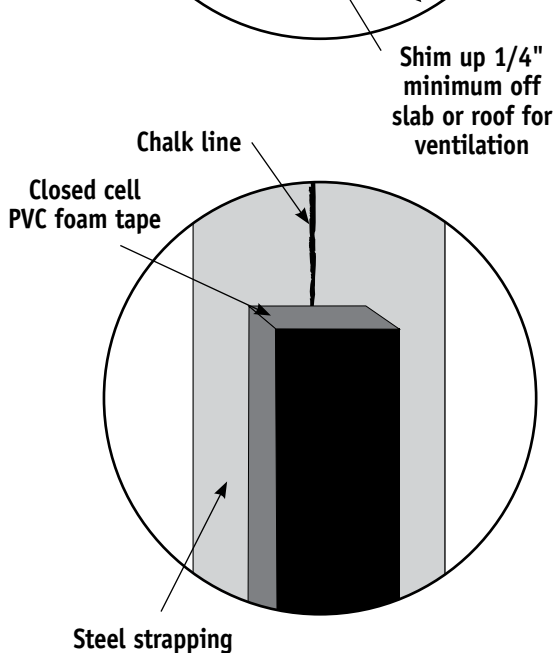

Step 2: Apply closed cell PVC foam tape

Using a chalk line, mark locations where caulk joints between panels will occur. The main drawing on the previous page shows the locations of three caulk joints. Two of them are vertical joints, one to the extreme left, and one to the extreme right. A horizontal joint is shown at the top of the drawing. These joints are indicated by the foam tape. A 1" gap is shown where the horizontal joint intersects the vertical joint (**Detail A**). This gap provides a path for drainage, and the masking tape "bridge" provides a backing for the caulk joint.

There are two reasons for installing foam tape behind joints. It prevents three-way caulk adhesion, which would cause the caulk joint to fail almost immediately. It also acts as a primary seal against water.

Note: It is important to keep the liner on the foam tape as it is applied to avoid stretching or inaccurate placement.

Note: For placement of foam tape: determine the middle of the joint and snap a line. Measure 1" away from center of joint and place your tape. Snap a new line in the center of the tape. To determine placement of panels at the joint, measure 1/4" on either side of the new center line on the foam tape.

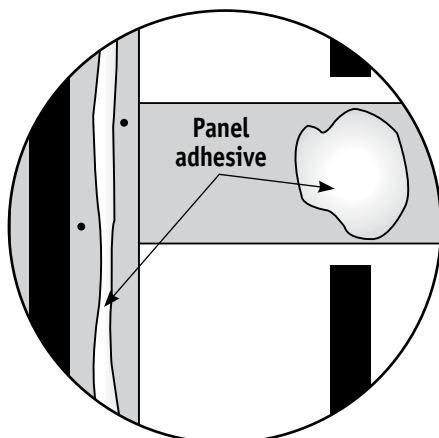

Step 3: Apply panel adhesive

Apply closed cell PVC foam tape behind the panel every 16" O.C. as shown in the main drawing on the opposite page. These strips of foam tape act as a shim and help to keep everything on the correct plane. Apply generous 3" dabs and 3/8" thick beads of panel adhesive to steel straps. Straps should be screwed down every 16"-24" O.C.

Many panel adhesives have a high solvent content that evaporates as it cures. This causes the adhesive to lose volume and shrink. Applying panel adhesive next to the foam tape will prevent the panels from being drawn in towards the gypsum, ensuring that the panels will maintain a flat appearance.

Installation Over Hat Channels (With or without building wrap)

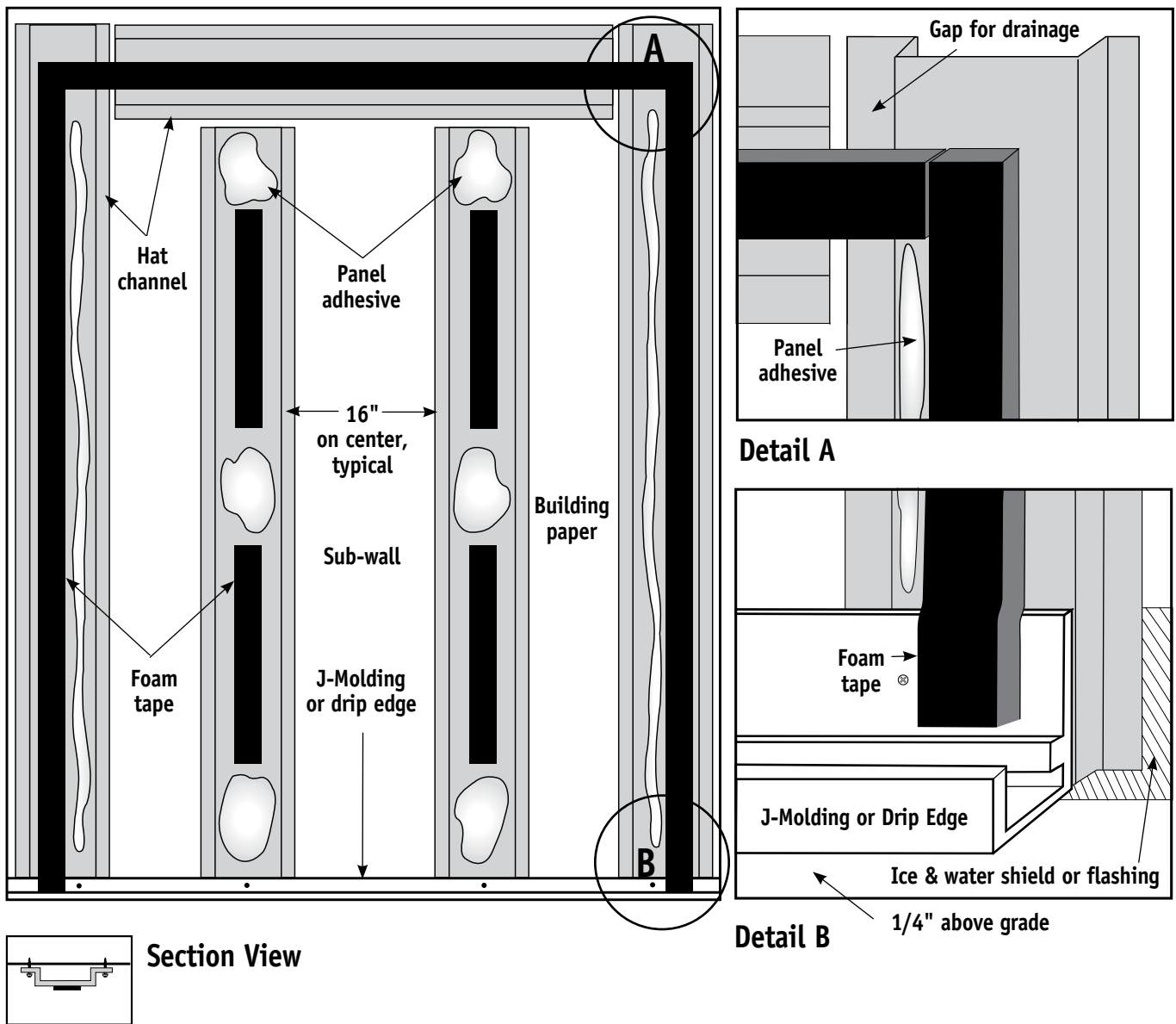

Again, the main drawing depicts the layout for one panel at ground level. As with previous substrates, J-Molding is shown at ground level. Either J-Molding or Drip Edge moldings can be used here. (See *1-Piece, Tight-Fit Installation Guide* for complete installation instructions for J- or Drip Edge Moldings.)

Hat channels are used for installing panels over surfaces such as brick or masonry that, while structural, cannot directly accept the Clip & Caulk System. They can also be used to create additional depth behind the panels if

required. Hat channels should be 3" wide across the face and a minimum of 1/2" in depth. Because of the depth created by the hat channel, drainage gaps are created with the foam tape itself rather than with masking tape.

See detail drawings A & B.

Installation Over Hat Channels (With or without building wrap)

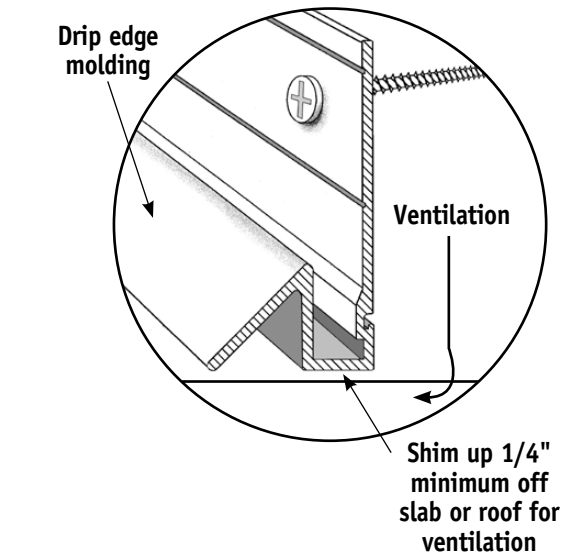

Step 1: Install J-Molding or Drip Edge

Start by installing drip edge moldings along the bottom edge of the wall for the panels to rest in. Keeping the molding 1/4" min. above ground level, use galvanized drywall screws to attach the molding to the plywood every 12" to 16" O.C. You may wish to use an ice and water shield to prevent water from getting to the plywood at ground level. This is shown in **Detail B** on the previous page.

See manufacturer's instructions for the proper use of ice and water shield.

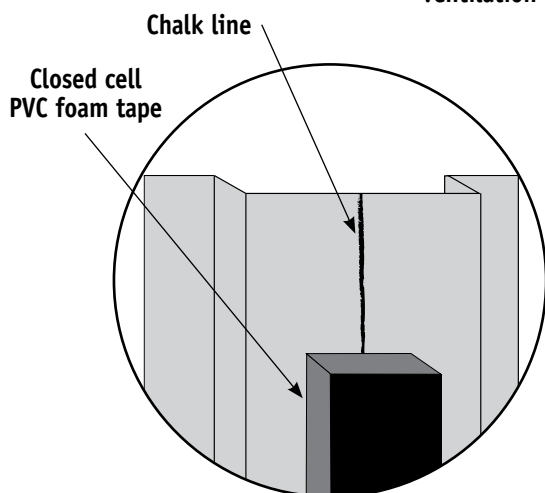

Step 2: Apply closed cell PVC foam tape

Using a chalk line, mark locations where caulk joints between panels will occur. The main drawing on the previous page shows the locations of three caulk joints. Two of them are vertical joints, one to the extreme left, and one to the extreme right. A horizontal joint is shown at the top of the drawing. These joints are indicated by the foam tape. A gap is shown where the horizontal hat channel meets the vertical hat channel (**Detail A**). This gap provides a path for drainage, and the foam tape "bridge" provides a backing for the caulk joint.

Note: It is important to keep the liner on the foam tape as it is applied to avoid stretching or inaccurate placement.

Note: For placement of foam tape: determine the middle of the joint and snap a line. Measure 1" away from center of joint and place your tape. Snap a new line in the center of the tape. To determine placement of panels at the joint, measure 1/4" on either side of the new center line on the foam tape.

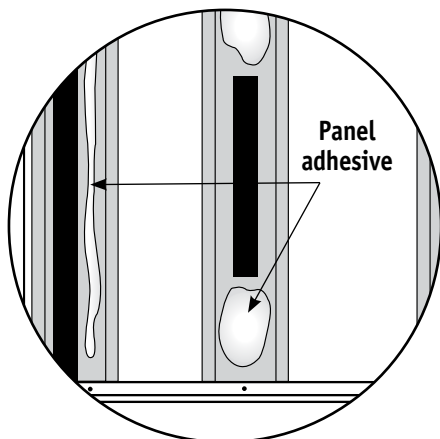

Step 3: Apply panel adhesive

Apply foam tape behind the panel every 16" O.C. as shown in the main drawing on the opposite page. These strips of foam tape act as a shim and help to keep everything on the correct plane. Apply generous 3" dabs and 3/8" thick beads of panel adhesive to the hat channels.

Many panel adhesives have a high solvent content that evaporates as it cures. This causes the adhesive to lose volume and shrink. Applying panel adhesive next to the foam tape will prevent the panels from being drawn in towards the substrate, ensuring that the panels will maintain a flat appearance.

To protect the integrity of the fluted panels, the panels are factory-sealed along the fluted edges and back-vented. Should you need to cut the panels, they must be edge-sealed immediately to a minimum depth of 3/8" to prevent debris from entering the flutes. The first panel edge should be fully cured before edge-sealing the second panel edge. In addition, if you cut the panels, make sure that there is at least one vent hole in the back of the panel and one vent hole through the core. Failure to do so will increase the likelihood of failed caulk joints. Refer to the following instructions for more information.

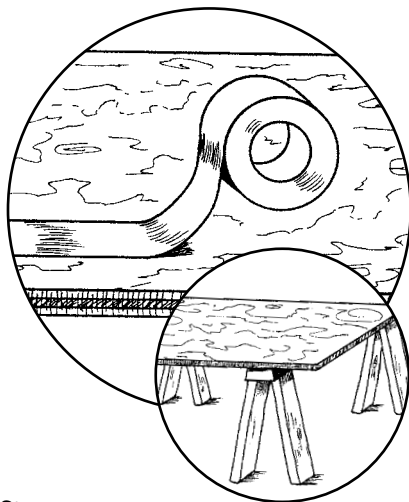

Set up a clean worktable

Using available materials (straight 2x4s, 3/4" flat sound plywood with smooth surface, or MDF plywood for precision work) construct a worktable at least 48" x 96" and at a comfortable working height. Place a strip of 2" masking tape along the short edge of the worktable. This will enable you to clean any excess caulk off the tabletop. To keep the panel from moving, drive two stop-screws into the tabletop at the end opposite the masking tape.

Step 1: Place panel on worktable

Center the edge of the panel you are about to seal over the masking tape on the worktable. Position the stop screws so that the panel does not move.

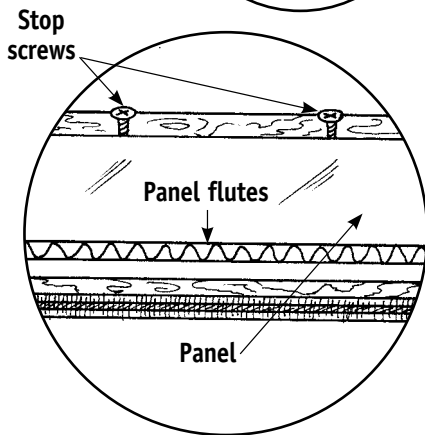

Step 2: Caulk fluted panel edges

Select a Laminators' approved silicone caulk (see page 15). Cut the end of the caulk tip at a 90° angle and a 3/16" diameter hole at the tip. Squeeze out a small amount of caulk, release the pressure, and wipe off the tip. Run a bead of caulk into the panel edge, forcing at least a minimum depth of 3/8" of caulk into the flutes. Continue for the entire length of the open flute panel edge.

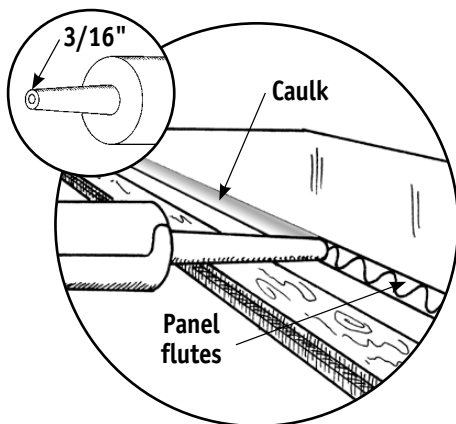

Caulk Manufacturers' Recommendation:

Panel surfaces and edges should be clean, dry, and free of all contaminants such as protective coatings, oils, grease, soap or detergent films, water, and dust.

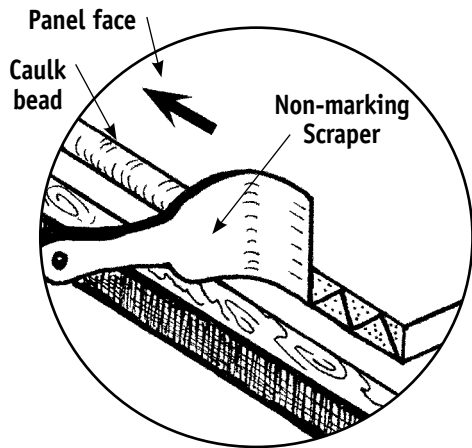

Step 3: Push caulk into flutes

Using a plastic scraper, force the bead of silicone caulk at least 3/8" into the flutes. After the edge has been caulked, pull the panel up and away from the caulk and the masking tape at a 45° angle.

Step 4: Remove excess caulk

Again, using a plastic scraper, clean any excess caulk off the masking and from the face and back of the panel. Clean the worktable surface before caulking another panel.

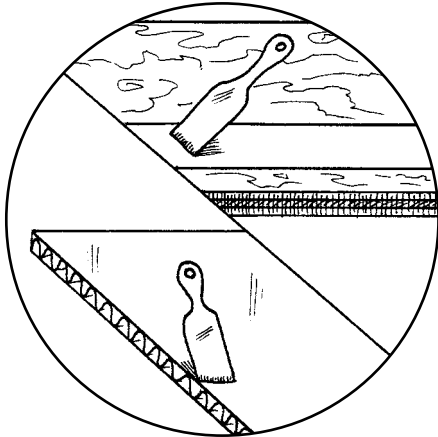

Step 5: To prevent caulk from bubbling

The first panel edge should be fully cured before edge-sealing the second panel edge. When caulking the panel edges, the silicone caulk should cure for a minimum of 1-1/2 hours. Overnight curing is preferred. Outside temperature and humidity will affect the amount of time needed for the caulk to cure. Final caulking of the joint should be done immediately after the panels have been installed on the wall surface and should be done in accordance with the caulk manufacturers' recommendation.

VENTING THE PANELS

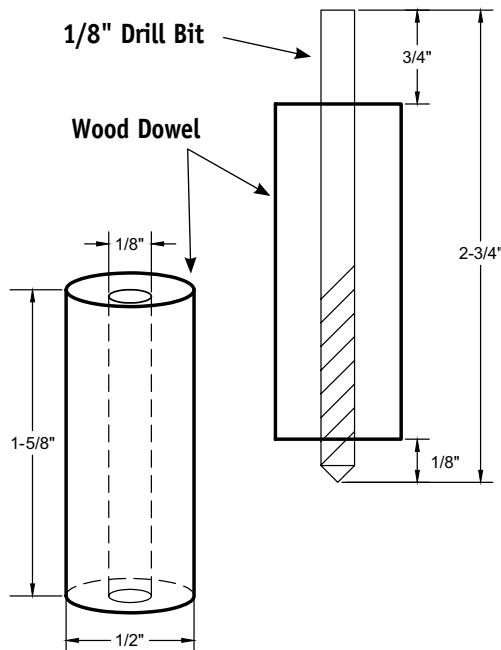

A Clip & Caulk installation with corrugated panels requires drilling and back-venting each panel prior to installation. Carefully follow the steps below to prevent failed caulk joints. Failure to do so may void your warranty.

Step 1: Prepare the Drill for Back-Venting the Panels

Create a drill stop to set the depth of the drill bit to prevent drilling through the face of the panel.

- 1) Cut 1/2" round dowel to a length of 1-5/8".
- 2) Drill 1/8" bit through dowel, leaving 1/8" of the bit exposed on the end, as shown at left.

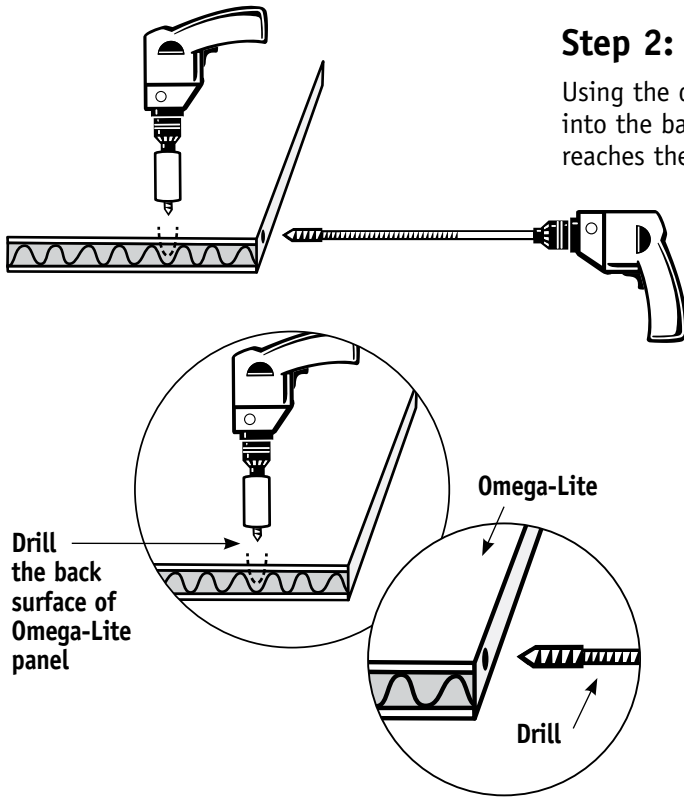

Step 2: Back-Vent the Panels

Using the drill prepared in the previous step, drill two 1/8" vent holes into the back of the panel. Penetrate the core, but stop before the bit reaches the back side of the face metal.

Step 3: Vent the Core

Laminators recommends using a 3-foot extended drill bit for this process, which is available from Laminators Incorporated. Be careful when using the extended drill bits as they are long and require additional support with a gloved hand to prevent them from breaking. It is imperative that the holes be drilled the entire length of the bit.

Using a 3-foot drill bit, drill through the panel perpendicular to the flutes. If panel is 3' or wider, drill from both sides. Drill two holes on each of the two solid sides of the core.

Note: It's important to note that back vents should not go up against a framing member or wet adhesive. Ensure that vents are open in the back of the panel prior to installation.

INSTALLING THE PANELS

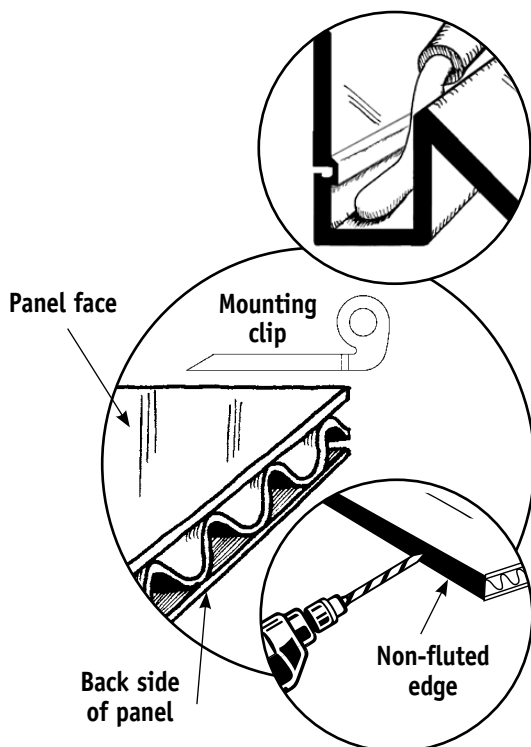

When installing panels with metallic finishes, it is very important that the directional arrows on the panel masking are oriented in the same direction.

Step 1: Install mounting clips

Insert mounting clips into the corrugations of the panels every 12" around panel perimeter. When you insert the clips on the "non-fluted" edge, drill 1/8" holes along this edge for easy clip attachment.

Step 2: Apply caulk to bottom molding

Using a Laminators' approved silicone caulk (see page 15), run enough caulk into the bottom molding so that it will seal the edge when the panel is inserted. Ensure that there are no skips in the caulk.

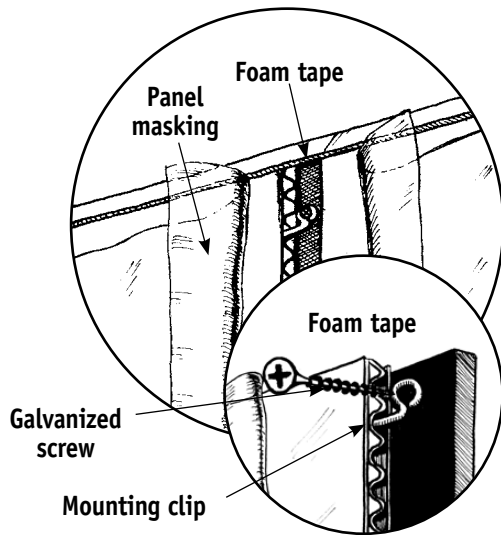

Step 3: Attach panels with mounting clips

Peel the panel masking back at the edges where the caulk joints fall. Using galvanized drywall or pan head screws, attach mounting clips through the closed cell PVC foam tape to the wall. Clips can be slightly bent, nudged, tightened, or loosened to align adjacent panels to give a very smooth surface.

1: 1/2" plywood or shims can be used as spacers to ensure that each panel has a uniform 1/2" gap between it and the next panel.

2: Caulk in indirect sunlight.

Note: If you can't proceed to final caulking, keep joint clean! If for any reason you cannot immediately caulk the panel joints the joints should be covered with painters' tape after the panel installation. 2" Scotch® Safe-Release Painters' Masking Tape (also known as Long Mask™ tape) is recommended. When you are able to caulk the panels, remove the tape and clean the joint.

Use methyl or ethyl alcohol to clean the joints, using a two-pass system. Spray the joint with a hand sprayer filled with alcohol, wipe with a clean, dry rag, and allow the joint to dry. Inspect the joint to be sure there is no water in the joint.

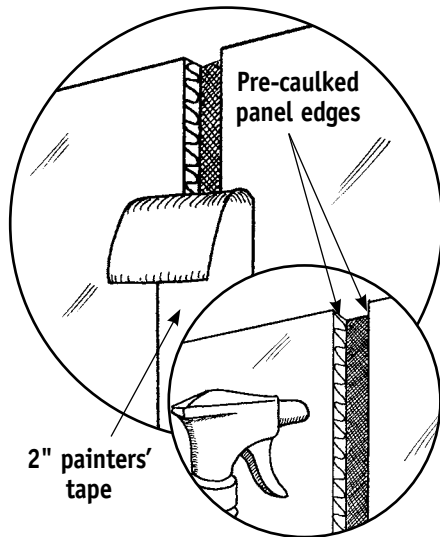

FINAL JOINT CAULKING

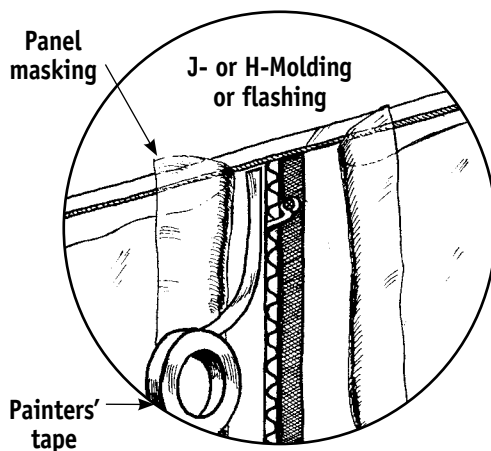

Step 1: Apply painters' tape

Apply painters' tape to adjacent panels on both sides of the joint. The tape should be placed approximately 1/16" away from the joint so that the caulk overlaps the face of the panel.

Note: Contaminated or dirty panel joints must be cleaned with alcohol, dried, and flame treated. Call Tech Support for specific instructions.

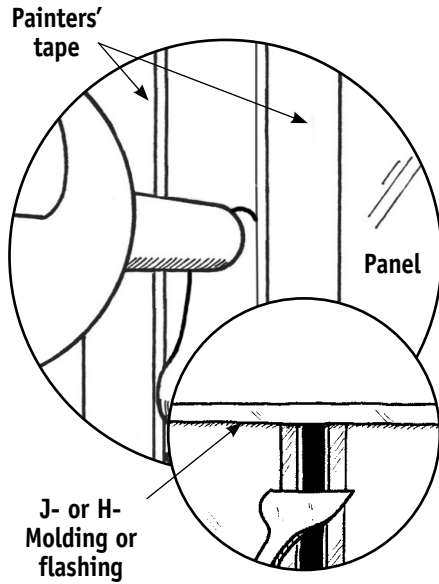

Step 2: Apply caulk to joint, then tool the joint

Run a bead of a Laminators' approved silicone caulk into the joints. Finish each joint with a non-marking, plastic scraper. The scraper should be pressed firmly against the panels and held at a sharp, downward angle (about 15°). Do one joint at a time so the caulk does not skin over before you can tool it.

When caulking 4-way intersections, caulk all vertical or horizontal joints (your choice) and let the caulk cure before caulking the intersecting joints.

Tooling the caulk will force caulk into the joint, resulting in a good bond. Tooling must be done before the caulk starts to skin over. Per manufacturers' instructions, skinning time can vary from 5 to 20 minutes. Only caulk 4' to 6' at a time to ensure a smooth finish.

Step 3: Remove tape

Peel the painters' tape off immediately after the joint is tooled.

Step 4: Remove panel masking

Finally, remove all protective masking from the panels.

Caution: All the masking must be removed within 2 weeks, otherwise it may affect the appearance of the panel and may be very difficult to remove.

Step 5: Apply trim to last panel in run

There are several end-of-run options. The most common ones include: a 1-piece H-Molding or a 2-piece J-Molding to cover the vertical edge of the last panel in a run. A panel can also terminate at a wall or mullion.

1-piece H-Molding: If a 1-piece molding is used, fill the channel with silicone caulk and attach it to the last panel edge of a run before installing the final panel. Use fasteners to secure the molding and backer rod and silicone caulk to finish the run as shown. Refer to 1-Piece, Tight-Fit Installation Guide.

2-piece J-Molding: If using 2-piece J-Moldings, run a bead of silicone caulk between the molding and the wall. Refer to 2-Piece, Snap-Fit Installation Guide.

In either case, all gaps should be caulked well with a Laminators' approved silicone caulk.

Aluminum Angle: Bend strips of aluminum 90° to create an angle. Place angle with one flat edge against the wall and perpendicular edge facing the end of the last panel, leaving a 3/8" space. Secure angle with screws. Run a bead of silicone caulk between angle and panel edge to seal the space between the angle and panel.

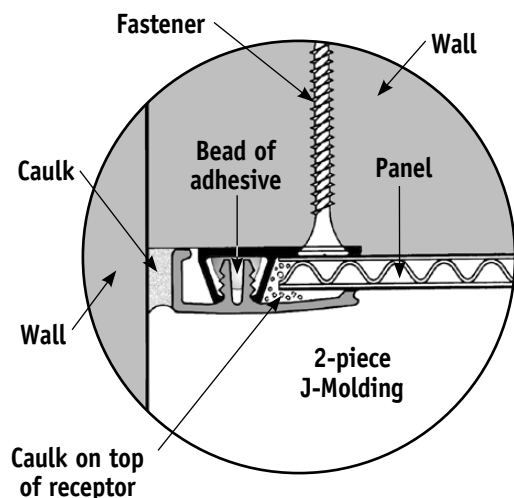
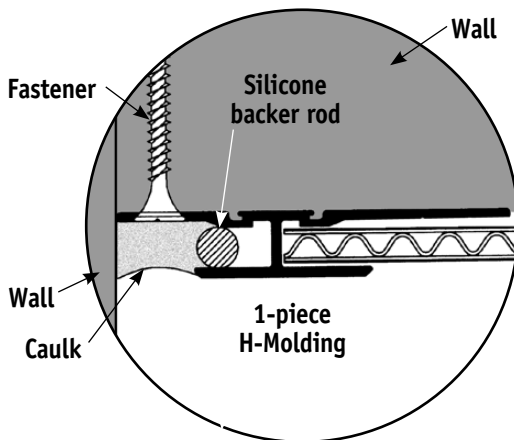

- Work table or saw horses and 3/4" particle board to create work table
- Aluminum brake capable of bending 0.032" aluminum
- Porter-Cable 3 HP router with guide or equivalent able to accept a 1/2" carbide shank
- Laminators' router bit (Part #RB 1/2)
 - Custom designed router bit only available from Laminators Inc. that forces bending into the middle of the groove and eliminates core show-through. Carbide with 1/2" shank.
- Miter saw or chop saw with 10" diameter blade
- Circular saw with 7-1/4", 40-tooth blade (min.)
- Jigsaw with 24-tooth, sheet metal cutting blade
- Caulking gun
- Screw gun
- Drill
 - 2-3/4" long (min.) 1/8" drill bit
 - 3-Foot long 1/8" drill bit (Part #DRILL BIT 36")
 - 1/2" round dowel to create drill stop
- Deburring tool (Part #DEBURRING TOOL)
- Aviation snips or heavy-duty scissors
- Plastic putty tool or scraper to remove excess caulk and adhesive from panels
- Metal single cut rectangular file with medium teeth
- Utility knife
- Tape measure
- Protective gear (safety glasses, gloves to handle panels, etc)

ESSENTIAL SUPPLIES

- Panels, moldings/extrusions as needed
 - J-Molding or Drip Edge (required) and end of run option (optional)
 - H-Molding for end of run option (optional)
- Color-matched flat stock
- Strapping
 - 0.40" aluminum or 20 ga. galvanized exterior sheet metal strips 3" x 8', 10', or 12'
- Furring strips or studs as needed
- Insulation, 3/4" foam to go between furring strips
- Ice & water shield or flashing
- Gaska Tape® V710, 3/16" x 2" or equivalent closed cell 7 lb. density polyvinyl chloride foam tape (Laminators Part #12847)
- Clip & Caulk metal clips (Laminators Part #50299FLAT, sold per 100)
- Silicone Caulk—The following caulks have been tested and meet requirements. Color-matched Pecora 890NST caulk is available from Laminators Inc. **Note:** *Minimum order quantities required for certain color-matched caulks.*
 - Pecora 890, 860, 896, 895
 - Dow Corning® 790, 995, 795, 983, 756, 791
 - GE SilGlaze® II, SilPruf®
 - Novaflex® Metal Roof Sealant
- Panel Adhesive— The following adhesives have been tested and meet requirements. Titebond® GREENChoice Premium Polyurethane Construction Adhesive is available from Laminators Incorporated.
 - Titebond® GREENChoice Premium Polyurethane Construction Adhesive (4222 VOC-compliant)
 - Titebond® Heavy-Duty Construction Adhesive (5262)
 - Liquid Nails 602 Subfloor (LN-602), 950 Polyurethane (LN-950), 902 for Subfloor (LN-902), or 901 for Heavy Construction (LN-901)
 - DAP 4000 Subfloor Adhesive
 - OSI Sealants PL400
- Screws
 - #6 x 1-1/4" bugle-head drywall or #8 or #10 x 1" Phillips Pan Head for securing clips into sheathing
 - #8 or #10 x 3/4" or longer, TEKS/3 screws to secure clips into steel studs
 - #6 x 1/2" and #6 x 1" Phillips Pan Head, TEKS/2 screws for mounting moldings to plywood or metal
- Wood shims to assist with spacing between panels
- Mineral spirits and rags to clean caulk from panels
- Touch-up paint

Note: Trademarks are registered by the companies noted.

How Much Will I Need?

For every 100 sq. ft. of Omega-Lite panels you will need:

- 3 tubes 11 oz. silicone caulk
- 1 tube 28 oz. panel adhesive
- 3 rolls 2" x 50' closed cell PVC foam tape
- 100 clips (1 per sq. ft.)

For the most current list of approved caulks and adhesives, visit our website.



In addition to the standard Clip & Caulk details, these standard extrusions are used by installers to complete attractive installations.

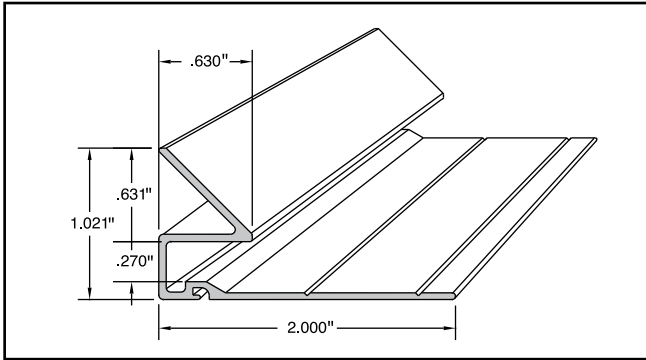

Item 4525X: Inside Corner (Drip Cap)

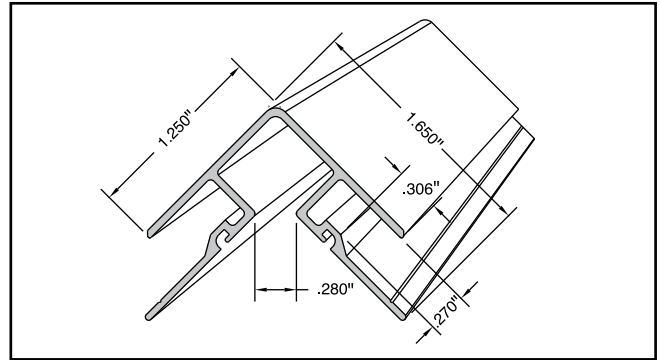

Item 4535X: Adjustable (Bendable) Outside Corner

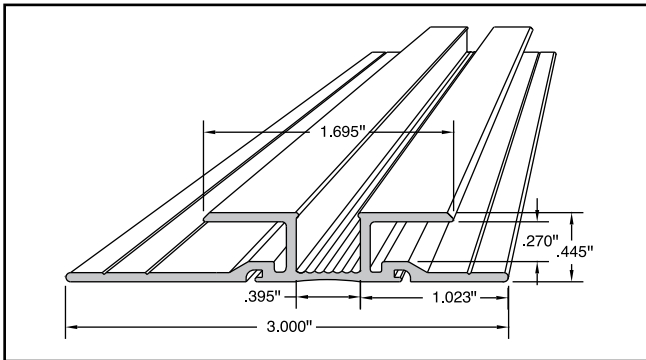

Item 4595X: Reveal H-Molding

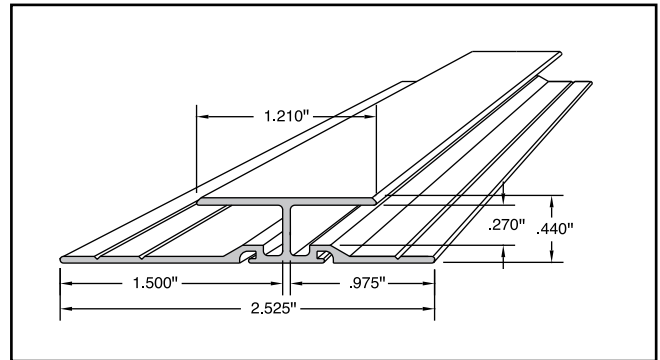

Item 4505X: H-Molding

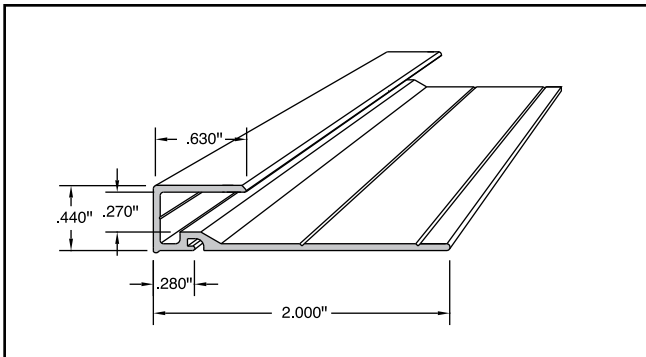

Item 4515X: J-Molding

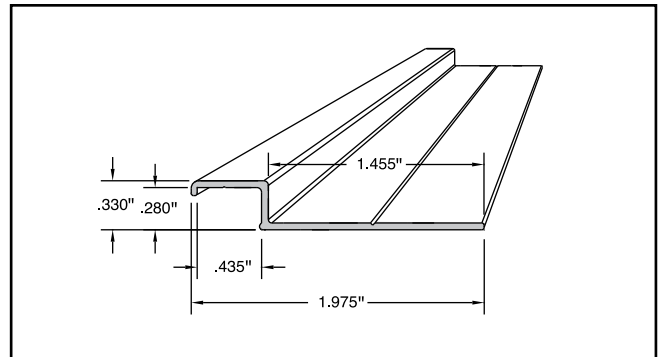

Item 4545X: Z-Molding

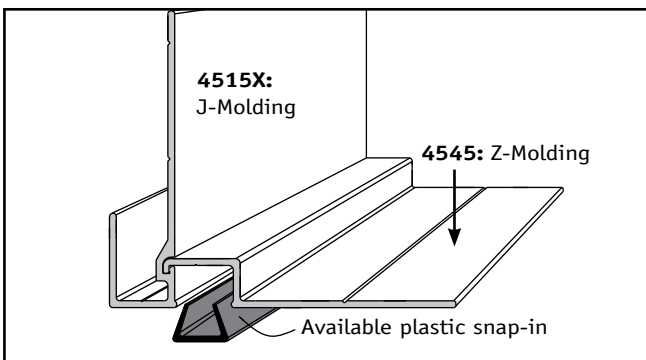

Fascia Soffit or Outside Corner (J-Molding & Z-Molding combined with plastic snap-in molding)

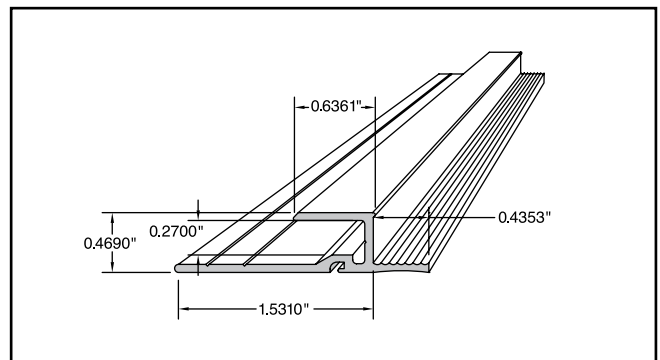

Item 4565X: Terminating J-Molding

Omega-Lite Panel Maintenance

Routine cleaning:

Omega-Lite panels should be washed periodically to keep them bright. Plain water and a clean cloth are all you need to remove ordinary dirt buildup. A mild, non-abrasive household detergent with a clean-water rinse can be used for more stubborn stains. Solvents such as alcohols, mineral spirits, naphtha, turpentine, and xylene can be applied with a soft cloth. Never soak panels in solvents.

For scratches and rub-marks:

Omega-Lite touch-up paint and re-paint instructions are available from Laminators. For larger paint repairs, call Laminators for standard paints designed for aluminum surfaces available at paint stores.

Keep harsh solvents away from finish:

Panel finishes are resistant to most but not all solvents and chemicals. You can safely use mineral spirits to remove uncured caulk and paints.

We suggest that the caulk build up enough strength in an overnight cure so that bubbles do not form.

Carefully review the caulk manufacturer's literature for skin formation, tack-free time, and cure times before using. Remember, your environmental condition is the biggest factor in deciding which caulk is appropriate for your project. Caulk only one joint at a time so that the caulk does not skin over before it can be tooled. Only caulk 4' to 6' at a time for a smooth finish.

It is important to only use caulk from our recommended list and to always test your caulk

in the environmental conditions you are currently working in to find the one that works best. Consult with us if your caulk is not performing as expected.

Apply a generous amount of panel adhesive to the sheathing to prevent it from drawing the panel towards the building as it dries; closed cell PVC foam tape should be placed out in the field of the panel where it will shim the adhesive to the proper thickness away from the furring or sheathing.

