

PERFORMANCE TEST REPORT

Rendered to:

GLASSCRAFT DOOR COMPANY

SERIES/MODEL: Portobello and Estancia

PRODUCT TYPE: 42" x 96" Single Inswing Hardwood Door

Title	Summary of Results
Uniform Load Deflection Test Pressure	+47.2 psf / -51.4 psf
Uniform Load Structural Test Pressure	+70.8 psf / -77.1 psf

Secure Electronic Seal
for Electronic Submittal

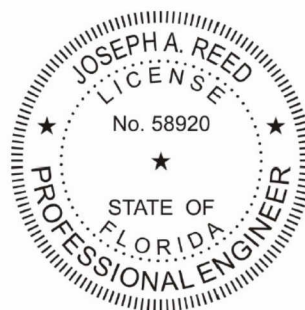

This report contains in its entirety:

- Cover Page: 1 page
- Report Body: 4 pages
- Sketch: 1 page
- Drawings: 5 pages



Digitally Signed by: Joseph A. Reed

Date: 2010.07.21 16:32:35 -04'00'

Reference should be made to Report No. 69320.01-801-44 for complete test specimen description and data.

PERFORMANCE TEST REPORT

Rendered to:

GLASSCRAFT DOOR COMPANY
2002 Brittmoore Road
Houston, Texas 77043-2209

Report No.: 69320.01-801-44

Revision 3: 07/21/10

Test Date: 12/05/06

Report Date: 12/08/06

**Record Retention End Date: 12/05/10

Project Summary: Architectural Testing, Inc. was contracted by GlassCraft Door Company to perform testing on a Series/Model Portobello and Estancia, 42" x 96" inswing hardwood door. Test specimen description and results are reported herein.

Test Method: The test specimen was evaluated in accordance with:

ASTM E 330-02, Test Method for Structural Performance of Exterior Windows, Curtain Walls and Doors by Uniform Static Air Pressure Difference

Test Specimen Description:

Series/Model: Portobello and Estancia

Product Type: 42" x 96" Inswing Hardwood Door

Overall Size: 43-5/8" wide by 98-3/4" high

Leaf Size: 42" wide by 96" high

Daylight Opening: 26-7/8" wide by 66" high

Glazing Details: Sealed insulating glass comprised of 1/8" thick tempered glass at the interior and 1/8" thick tempered decorative textured glass at the exterior. A 1/2" aluminum spacer system was used providing 3/4" overall thickness. Interior glazed with double sided butyl tape and a nailed-on wood glazing bead secured by 1" long by 0.04" by 0.05" rectangular shank brad nails with 0.05" by 0.08" heads (18 gauge brad nail) 1" from each corner and on 6" spacing thereafter.

Test Specimen Description: (Continued)

Weatherstripping: One five finger vinyl sweep at the bottom of the door leaf. One row of custom shaped foam-filled vinyl weatherstrip at the head and jambs.

Frame Construction: The door frame was constructed of 4-5/8" by 1-1/4" hardwood head and jambs, and included an adjustable extruded aluminum and composite threshold. The head and jambs were kerfed to accept the weatherstripping. The corners were coped and butted and secured with two #8 x 1-1/2" screws and five #8 x 3" screws at the threshold. And four #8 x 1-1/2" screws and two #8 x 3" screws at the head.

Leaf Construction: The door leaf was constructed of 1-3/4" thick hardwood and utilized a glued cove and bead joint, reinforced with 1/2" diameter by 4-1/2" long wood dowels. Two dowels were located at the top and middle rail to stile joint, and four dowels were located at the bottom rail to stile joint.

Hardware: One Schlage F-300 Series single-point lockset 36" from bottom of the leaf and one Schlage deadbolt located 41-5/8" from the bottom of the leaf. Four 4" butt type hinges were fastened to each leaf with four #8 x 3" screws. Each hinge was secured to the jamb with two #8 x 3" screws and two #8 x 1" flat head screws. The hinges were located at 7", 32-1/4", 57-1/2" and 82-3/4" from the top of the jamb. Surface bolts were attached to the top and bottom of the leaf with four #10 x 1" flat head machine screws with a 1-1/2" long blind nut. Strike plates for the surface bolts were attached to the head with two #8 x 3" screws and to the threshold with two #10 x 3" sheet metal screws.

Drainage: Sloped sill.

Installation: The jambs were secured to a #2 Yellow Pine test buck with pairs of #8 x 3" screws 6" from each corner and 24" on center. And, two #8 x 3" screws located at the head of the unit and two #8 x 3" screws through the strike plate (24 total).

Test Results: The results are tabulated as follows:

Uniform Load Deflection per ASTM E 330 (Deflections were taken on the door) (Load held for 25 seconds)	<u>Indicator Number</u>				
	1	2	3	4	5
47.2 psf (positive)	0.16"	0.45"	0.53"	0.39"	0.17"
51.4 psf (negative)	0.17"	0.31"	0.35"	0.28"	0.18"

Uniform Load Structural per ASTM E 330 (Permanent sets were taken on the door) (Load held for 10 seconds)	<u>Indicator Number</u>				
	1	2	3	4	5
70.8 psf (positive)	0.02"	0.03"	0.04"	0.04"	0.03"
77.1 psf (negative)	0.01"	0.03"	0.04"	0.03"	0.02"

Note: See Architectural Testing Sketch #1 for indicator locations

**Detailed drawings, data sheets, representative samples of test specimens, a copy of this report, or other pertinent project documentation will be retained by Architectural Testing, Inc. for a period of four years from the original test date. At the end of this retention period, such materials shall be discarded without notice and the service life of this report will expire.

Results obtained are tested values and were secured by using the designated test methods. This report does not constitute certification of this product nor an opinion or endorsement by this laboratory. It is the exclusive property of the client so named herein and relates only to the specimen(s) tested. This report may not be reproduced, except in full, without the written approval of Architectural Testing, Inc.

For ARCHITECTURAL TESTING, INC



Digitally Signed by: Andy Cost

Andy Cost
Laboratory Manager



Digitally Signed by: Joseph A. Reed

Joseph A. Reed, P.E.
Director – Engineering and Product Testing

JS/JAR:jar/cmd

Attachments (pages): This report is complete only when all attachments listed are included.

- Appendix-A: Sketch (1)
- Appendix-B: Drawings (5)

Revision Log

<u>Rev. #</u>	<u>Date</u>	<u>Page(s)</u>	<u>Revision(s)</u>
0	12/22/06	N/A	Original report issue
1	02/06/07	All	Florida P.E. Review
2	03/06/07	Cover page, Page 1	Changed Series/Model
3	07/21/10	1, 3	Replaced Expiration Date wording with Record Retention End Date. Replaced cosigner James Sturdevant with Andy Cost.

Appendix A

Sketch

REV	DATE	DESCRIPTION	BY

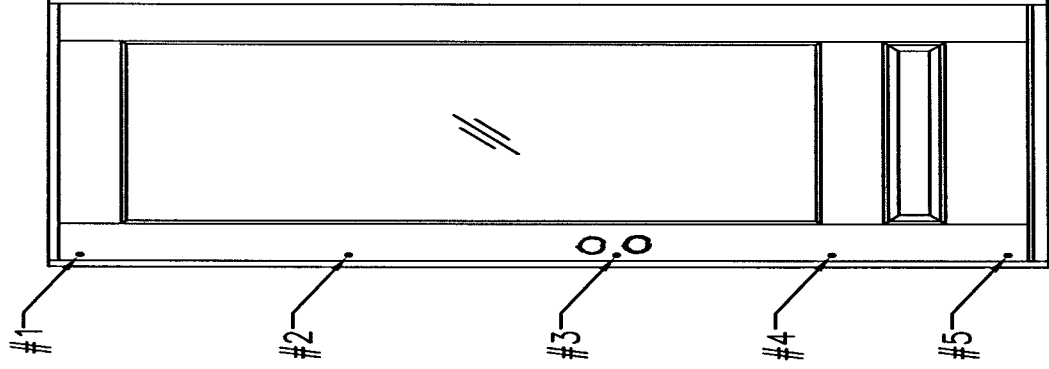

PROJECT NO.
69320.01
801-44

PROJECT NAME: INSWING HARDWOOD DOOR

CLIENT: GLASS CRAFT



DRAWING

INDICATOR SKETCH

DWG. BY: JFS
DATE: 12/08/06
SHEET 1 OF 1

Appendix B

Drawings

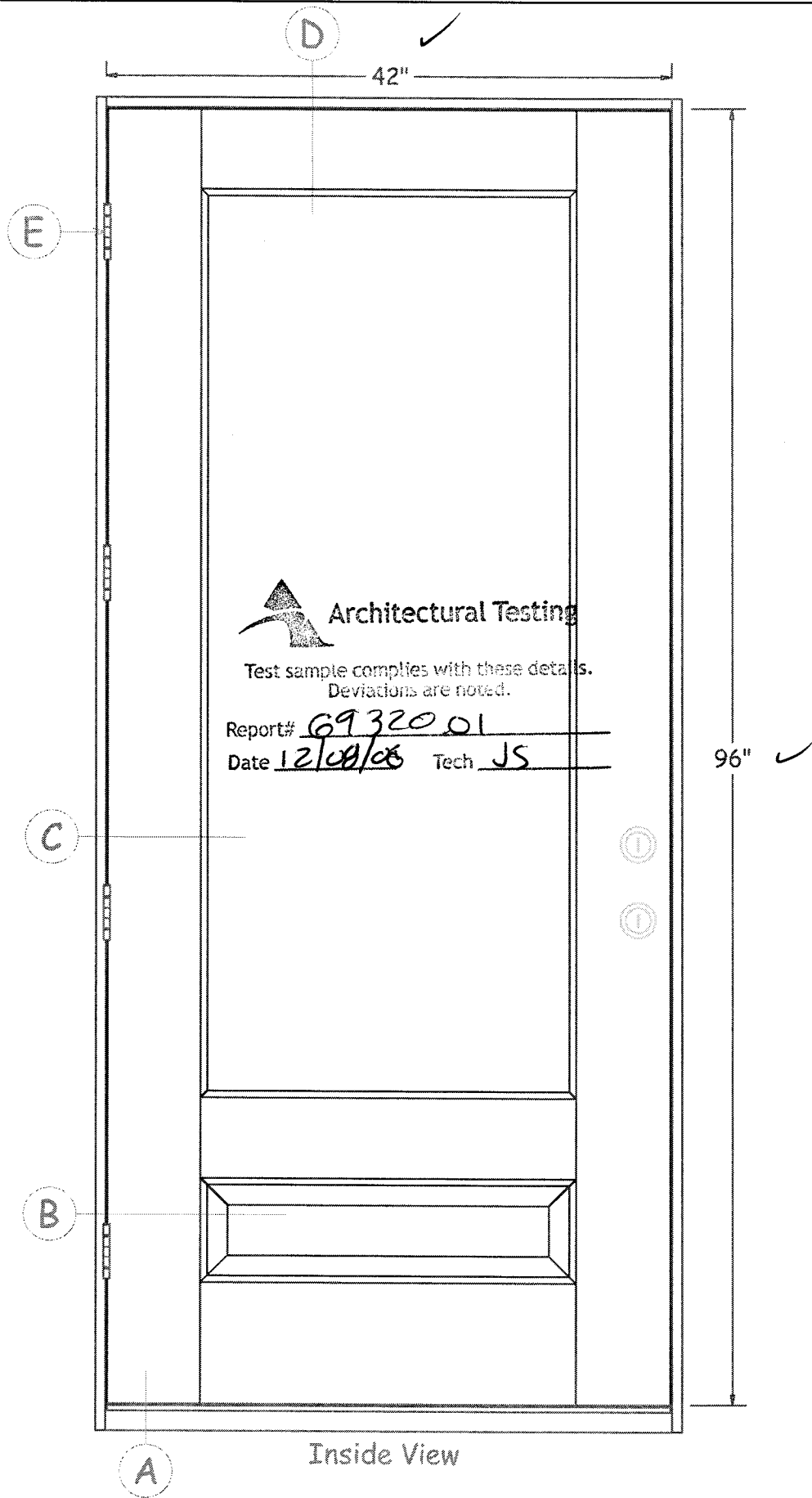

Inside View

Glass*Craft
 Door Company
 Houston Texas 77043 (713)-690-8282

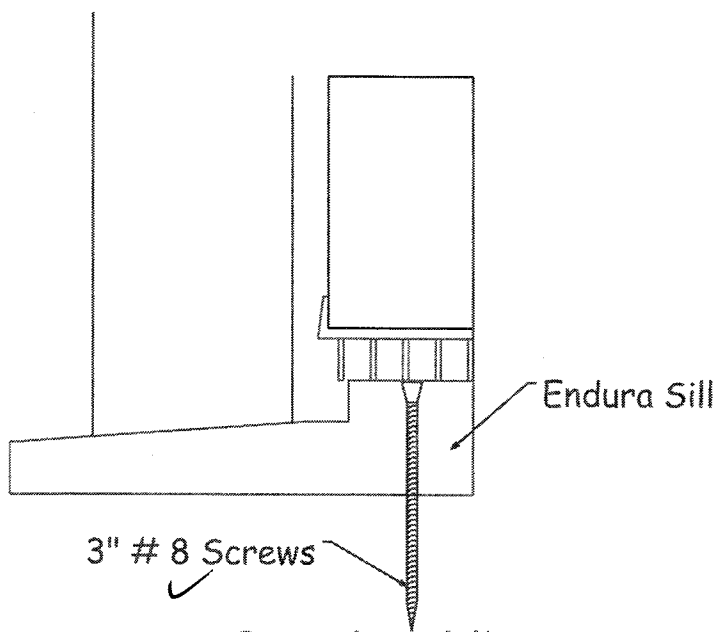

Section View

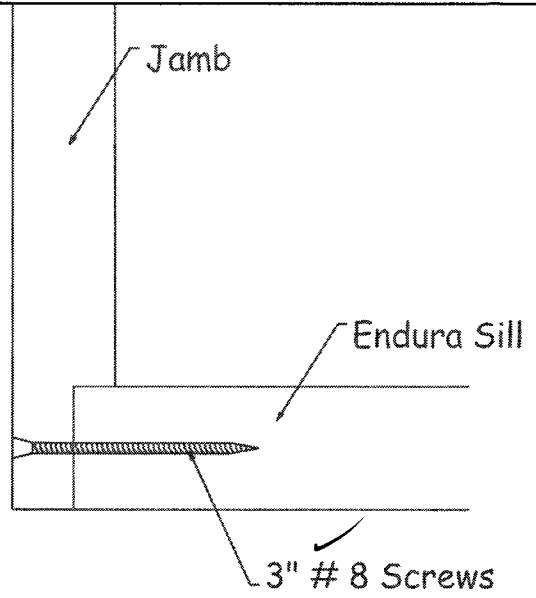

Inside View

A

Threshold In Swing

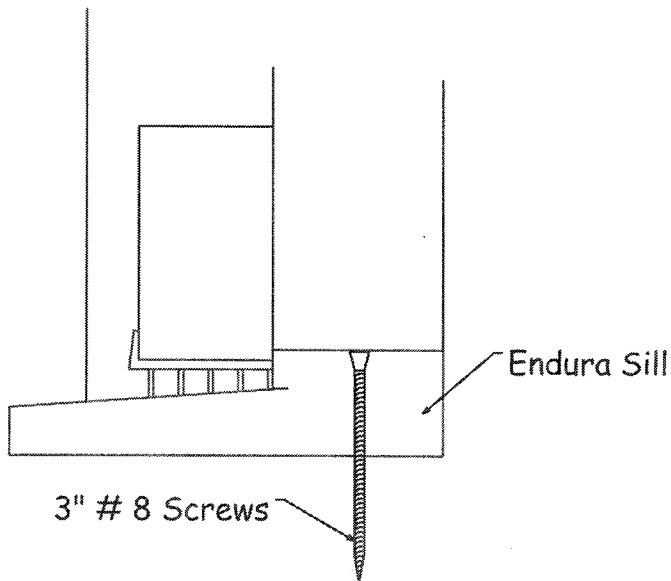

Section View

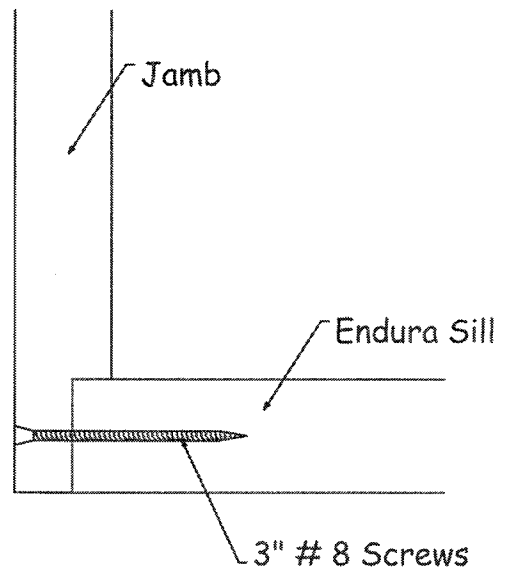

Inside View

A

Threshold Out Swing



Architectural Testing

Test sample complies with these details.
Deviations are noted.

Report# 69 320 01
Date 12/08/06 Tech JS

Glass*Craft

Door Company

Houston Texas 77043 (713)-690-8282

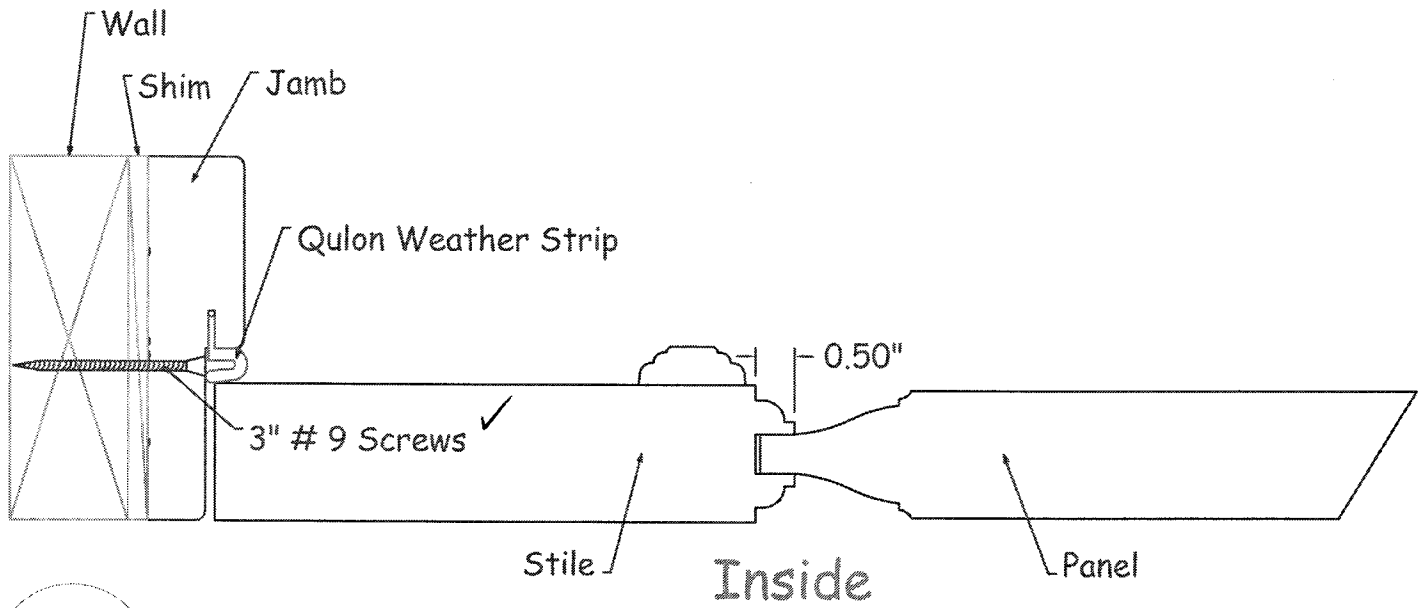

B Panel

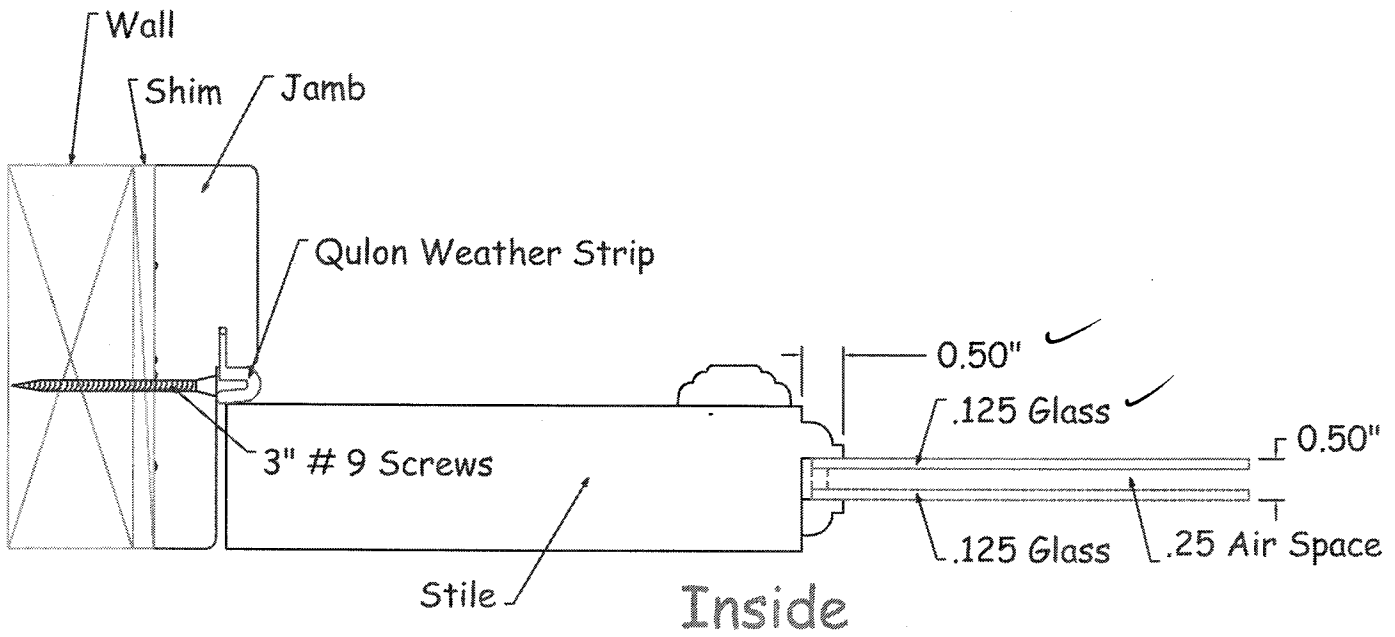

C Glass



Architectural Testing

Test sample complies with these details.
Deviations are noted.

Report# 69320.01
Date 12/8/06 Tech JS

Glass*Craft
Door Company
Houston Texas 77043 (713)-690-8282

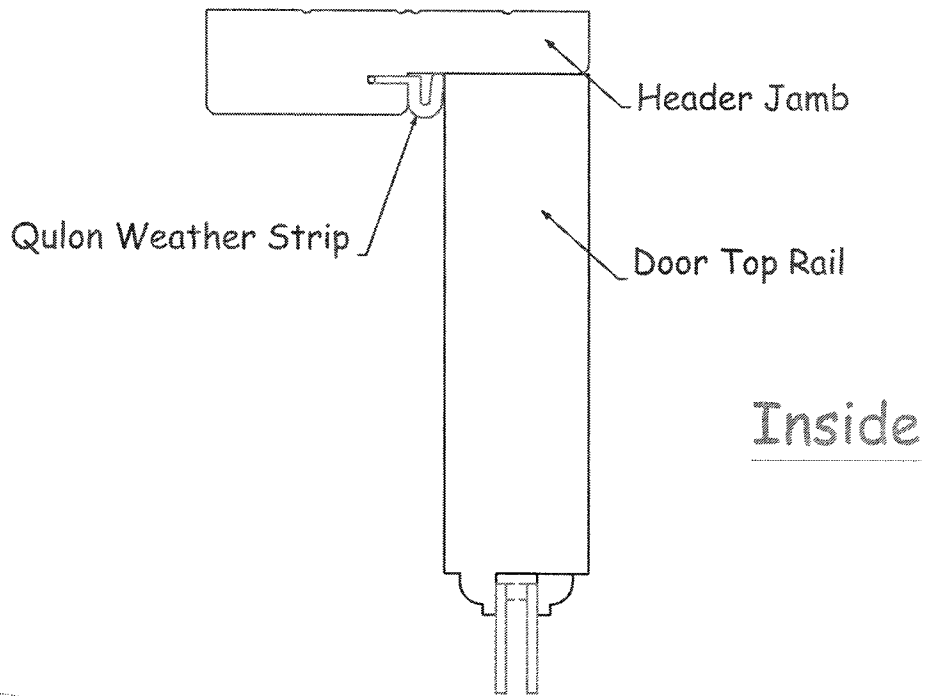

D

Header

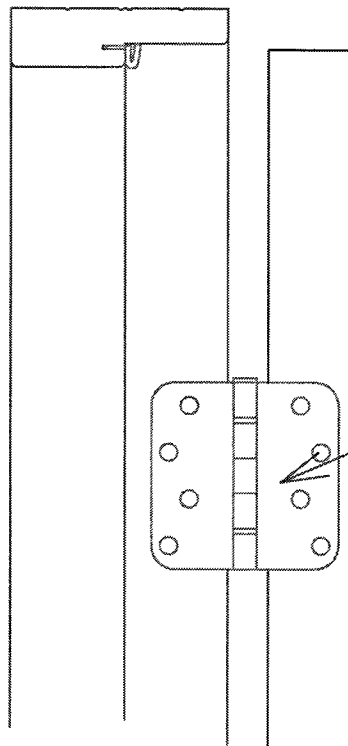

Penrond 4"x4"
5/8" Radius
Hinge



Architectural Testing

Test sample complies with these details.
Deviations are noted.

Report# 6932001

Date 12/08/06 Tech JS

E

Door Hinge

Glass*Craft

Door Company

Houston Texas 77043 (713)-690-8282

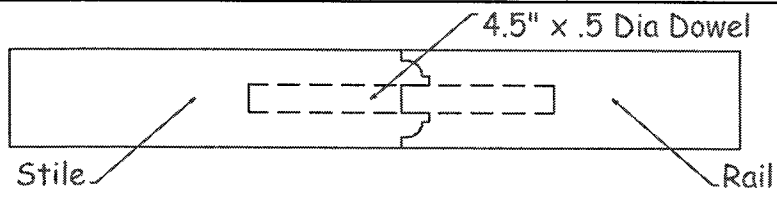

42"

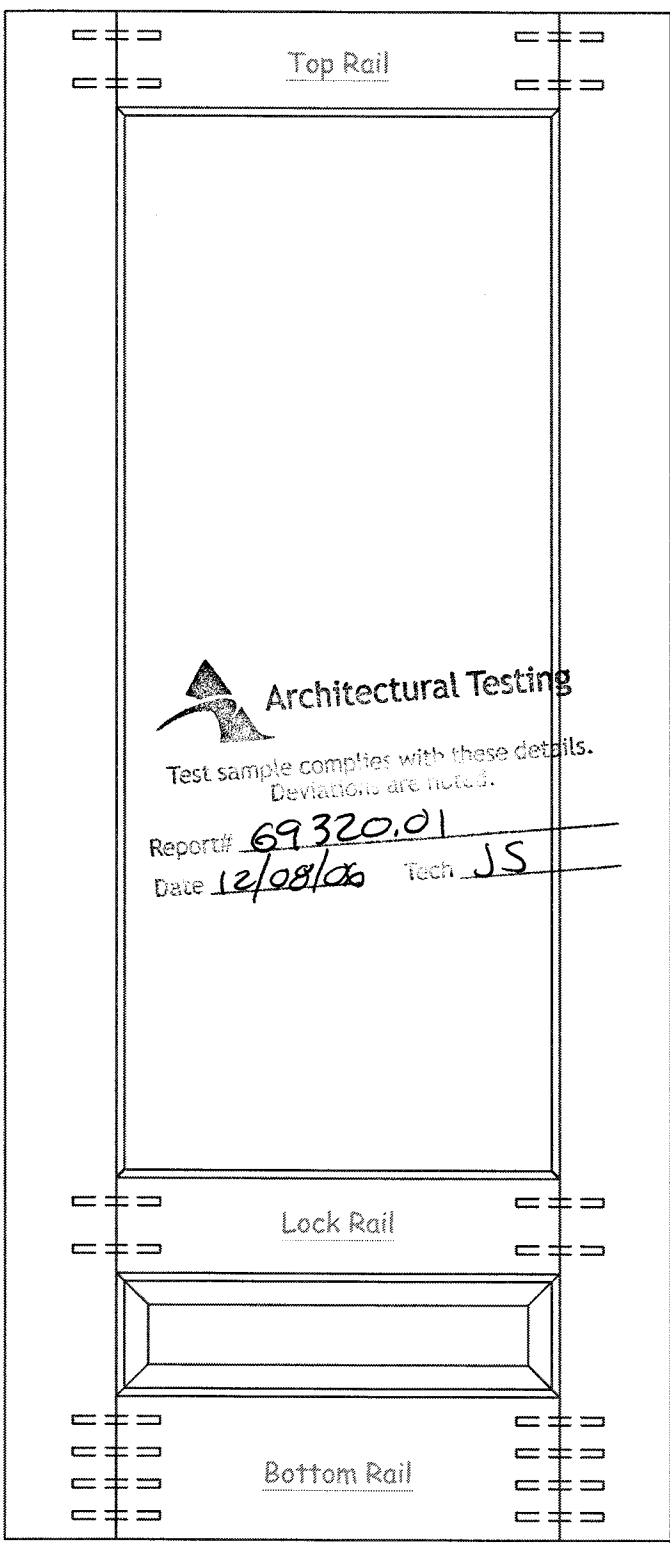

Architectural Testing
 Test sample complies with these details.
 Deviations are noted.
 Report# 69320.01
 Date 12/08/06 Tech JS

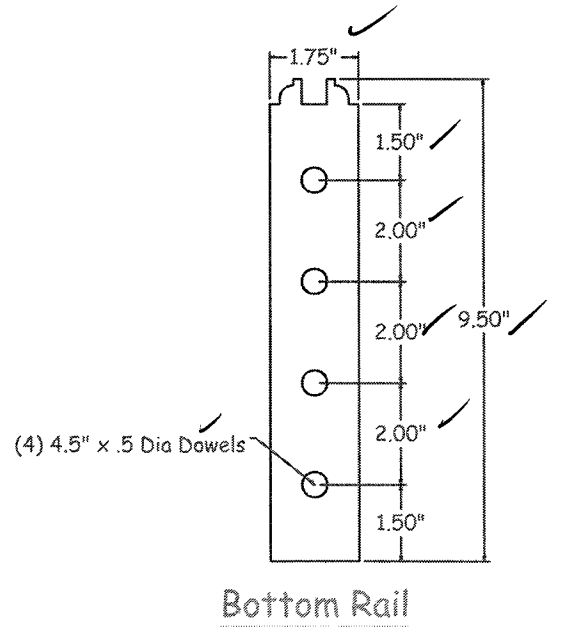
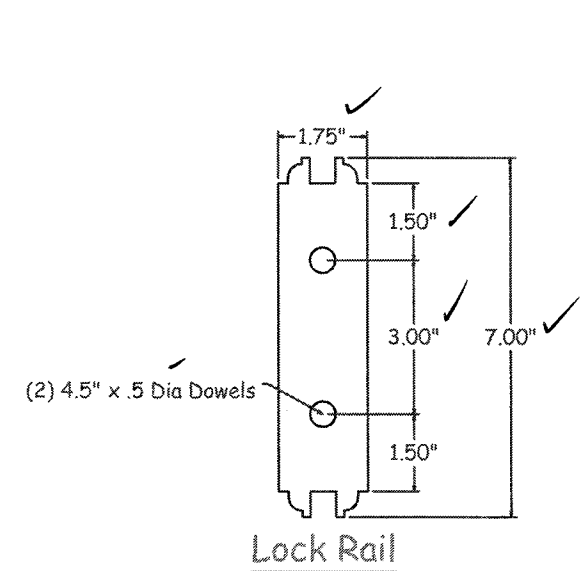
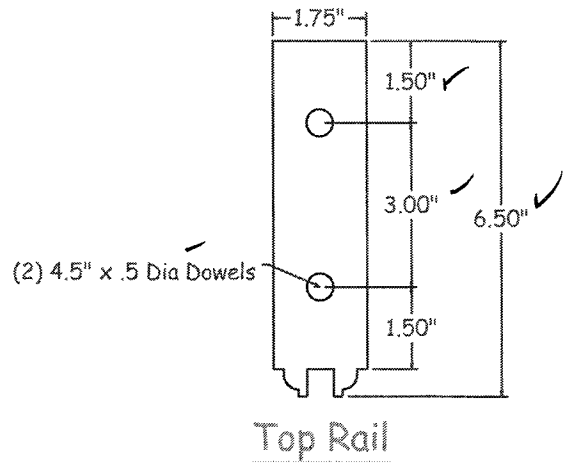

Glass*Craft
 Door Company
 Houston Texas 77043 (713)-690-8282