

# PICTURE WINDOW - NON-IMPACT

## GENERAL NOTES:

1. THE PRODUCT SHOWN HEREIN IS DESIGNED AND MANUFACTURED TO COMPLY WITH THE FLORIDA BUILDING CODE (FBC), CURRENT EDITION.
2. GLAZING OPTION: (SEE SHEET 3)
3. CONFIGURATIONS: "O". ARCHITECTURAL SHAPES INCLUDE, BUT ARE NOT LIMITED TO, THOSE SHOWN ON SHEET 2.
4. DESIGN PRESSURE RATING (SEE SHEET 4):  
 -NEGATIVE DESIGN LOADS BASED ON, TESTED PRESSURE AND GLASS TABLES ASTM E-1300-04e01/09.  
 -POSITIVE DESIGN LOADS BASED ON, TESTED PRESSURE, WATER INFILTRATION TEST PRESSURE AND GLASS TABLES ASTM E-1300-04e01/09.
5. ANCHORAGE: THE 33 1/3% STRESS INCREASE HAS NOT BEEN USED IN THE DESIGN OF THIS PRODUCT. SEE SHEET 6 FOR ANCHOR DETAILS. WINDLOAD DURATION FACTOR Cd=1.6 WAS USED FOR WOOD ANCHOR CALCULATIONS.
6. NOT APPROVED FOR IMPACT RESISTANCE. IMPACT PROTECTIVE SYSTEM IS REQUIRED IN WIND BORNE DEBRIS REGION.
7. ALL FRAMES FULLY WELDED.
8. SERIES / MODEL DESIGNATION PW-615.
9. THE DESIGNATION X AND O STAND FOR THE FOLLOWING:  
 O = FIXED SASH
10. SECTION CALLOUTS APPLY TO ALL ELEVATIONS IN A SIMILAR LOCATION.
11. PICTURE WINDOWS CAN BE INSTALLED IN ANY ORIENTATION.



## 615 PVC PICTURE WINDOW NON-IMPACT

PROPRIETARY AND CONFIDENTIAL  
 THE INFORMATION CONTAINED IN THIS DRAWING IS THE SOLE PROPERTY OF CUSTOM WINDOW SYSTEMS, INC. ANY REPRODUCTION IN PART OR AS A WHOLE WITHOUT THE WRITTEN PERMISSION OF CUSTOM WINDOW SYSTEMS, INC IS PROHIBITED.

FLORIDA APPROVAL NO.:  
 18147

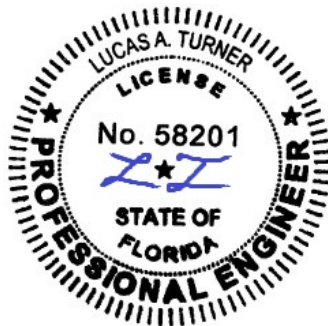

9/13/2023

LUCAS A. TURNER, P.E.  
 FL PE # 58201  
 Turner Engineering & Consulting, Inc.  
 2428 Old Natchez Trc Trl  
 Camden, TN 38320  
 PH. 941-380-1574

SHEET DESCRIPTION:  
 GENERAL NOTES AND ELEVATIONS

DRAWN BY: MCS	DATE: 8/31/2023
DWG #: CWS-1112	REV.: C
SCALE: 1:20	SHEET 1 OF 6

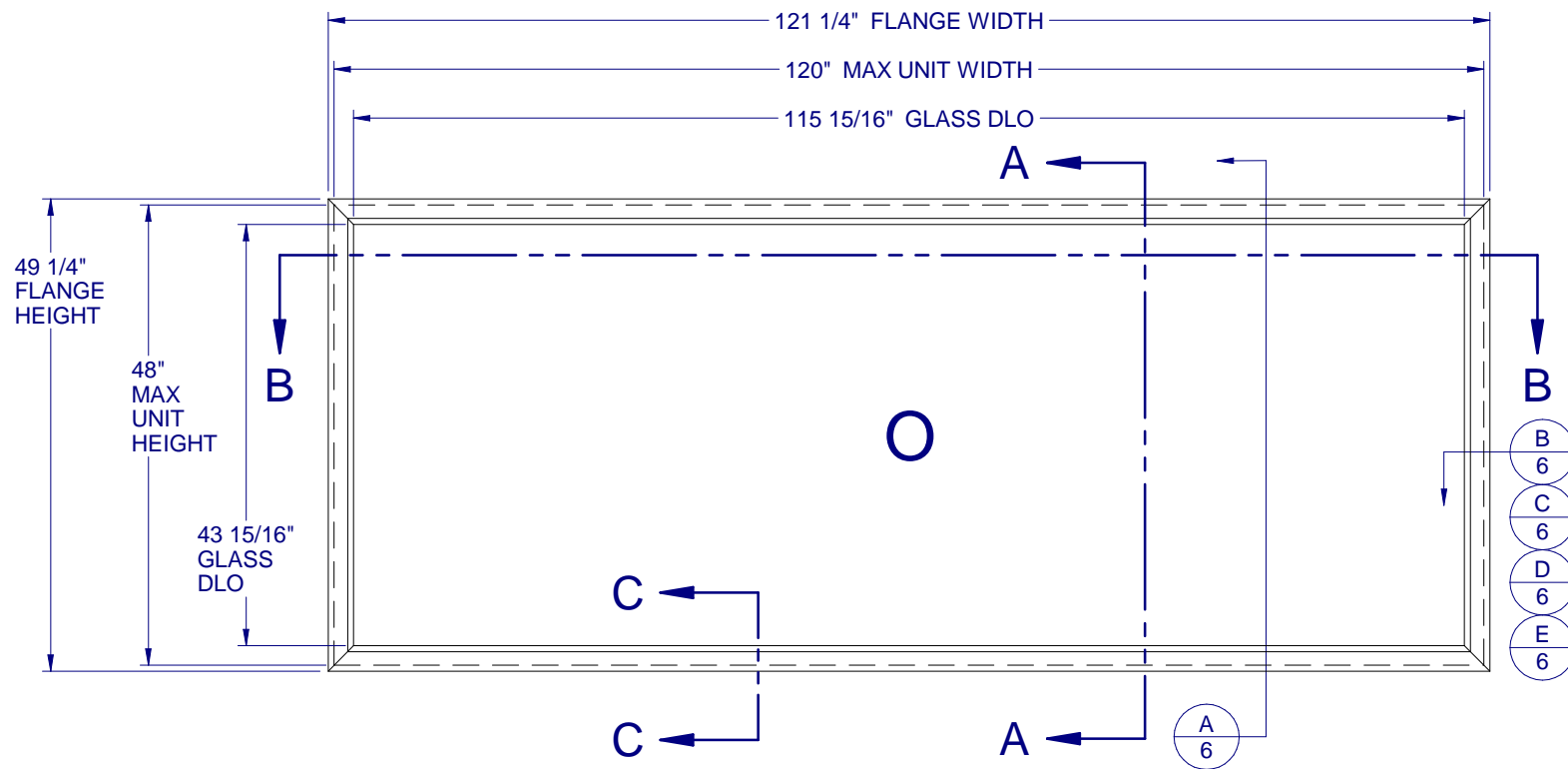

### TABLE OF CONTENTS

GENERAL NOTES & ELEVATIONS.....	1
ARCHITECTURAL SHAPES.....	2
SECTION VIEWS & GLAZING DETAIL.....	3
DP CHART, BOM & EXTRUSIONS.....	4
ANCHOR SCHEDULE & NOTES.....	5
INSTALLATION DETAILS.....	6

MAX. UNIT SIZE	DESIGN PRESSURE RATING	IMPACT RATING
120" x 48"	SEE COMPARATIVE ANALYSIS CHART, SHEET 4	NONE

**615 PVC  
PICTURE WINDOW  
NON-IMPACT**

PROPRIETARY AND CONFIDENTIAL  
THE INFORMATION CONTAINED IN  
THIS DRAWING IS THE SOLE  
PROPERTY OF CUSTOM WINDOW  
SYSTEMS, INC. ANY  
REPRODUCTION IN PART OR AS A  
WHOLE WITHOUT THE WRITTEN  
PERMISSION OF CUSTOM WINDOW  
SYSTEMS, INC IS PROHIBITED.

FLORIDA APPROVAL NO.:

18147



9/13/2023

LUCAS A. TURNER, P.E.  
FL PE # 58201  
Turner Engineering &  
Consulting, Inc.  
2428 Old Natchez Trc Trl  
Camden, TN 38320  
PH. 941-380-1574

SHEET DESCRIPTION:

**ARCHITECTURAL  
SHAPES**

DRAWN BY: MCS	DATE: 8/31/2023
DWG #: CWS-1112	REV.: C
SCALE: 1:20	SHEET 2 OF 6

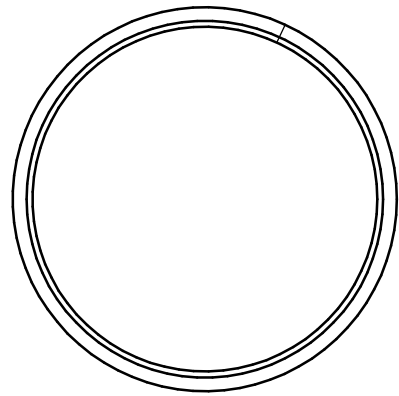

FULL CIRCLE

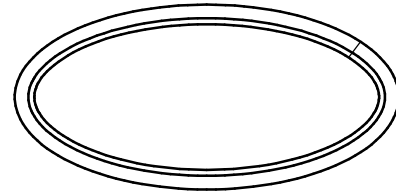

FULL ELLIPSE (OVAL)

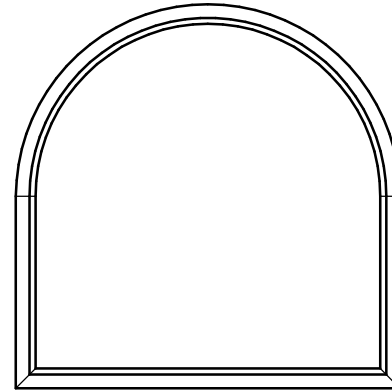

TOMBSTONE

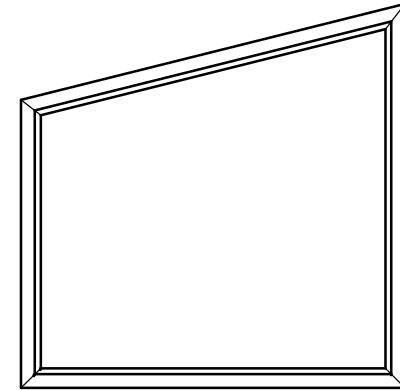

TRAPEZOID

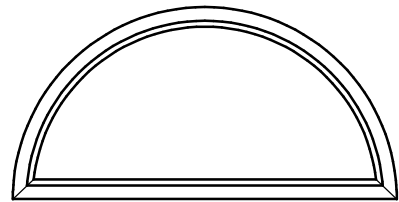

1/2 CIRCLE

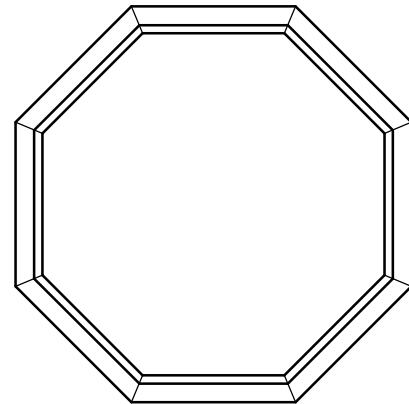

OCTAGON

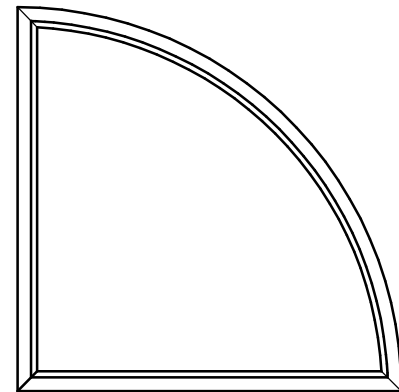

1/4 CIRCLE

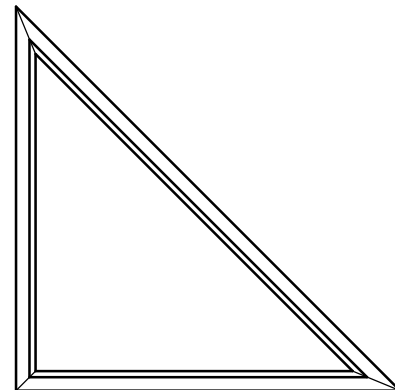

TRIANGLE

NOTES:

1. SEE SHEET 5 FOR DETAILED ANCHOR INSTALLATION REQUIREMENTS.
2. THRU FRAME - MASONRY, WOOD OR METAL OPENING.  
THRU FIN - WOOD OPENING.
3. OVERALL SIZE MUST NOT EXCEED THE MAX. WIDTH AND HEIGHT OF  
RECTANGULAR WINDOWS ON SHEET 1.
4. ANCHOR SPACING FOR ARCHITECTURAL FLANGE AND FIN WINDOWS  
MUST FOLLOW THE LAYOUTS SHOWN ON SHEET 5, WITH ANCHOR  
SPACING MEASURED ALONG THE LENGTH OF THE PRODUCT.



1900 SW 44TH AVE.  
OCALA, FLORIDA 34474  
WWW.CWS.CC

**615 PVC  
PICTURE WINDOW  
NON-IMPACT**

**PROPRIETARY AND CONFIDENTIAL**  
THE INFORMATION CONTAINED IN THIS DRAWING IS THE SOLE PROPERTY OF CUSTOM WINDOW SYSTEMS, INC. ANY REPRODUCTION IN PART OR AS A WHOLE WITHOUT THE WRITTEN PERMISSION OF CUSTOM WINDOW SYSTEMS, INC IS PROHIBITED.

FLORIDA APPROVAL NO.:  
18147



9/13/2023

LUCAS A. TURNER, P.E.  
FL PE # 58201  
Turner Engineering & Consulting, Inc.  
2428 Old Natchez Trc Trl  
Camden, TN 38320  
PH. 941-380-1574

SHEET DESCRIPTION:

**SECTION VIEWS AND  
GLAZING DETAIL**

DRAWN BY: MCS	DATE: 8/31/2023
DWG #: CWS-1112	REV.: C
SCALE: 1:1	SHEET 3 OF 6

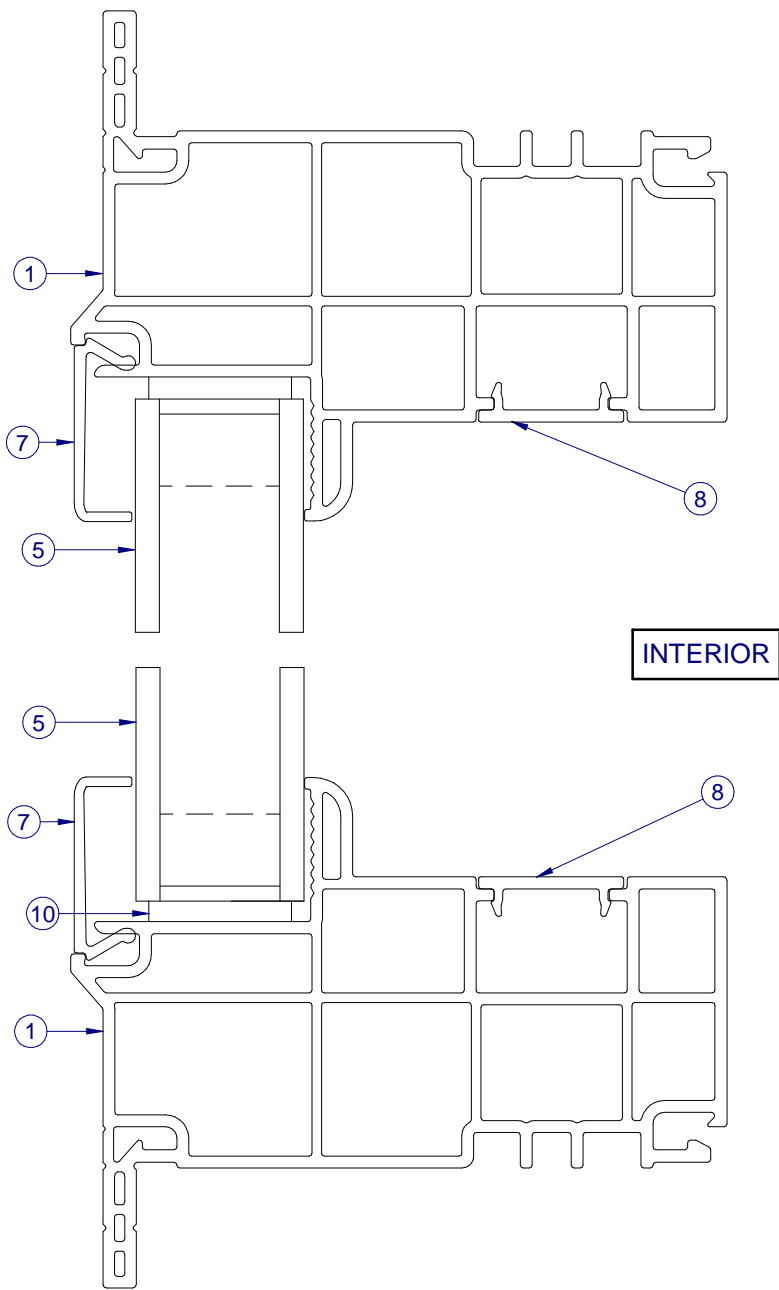

SECTION VIEW A-A

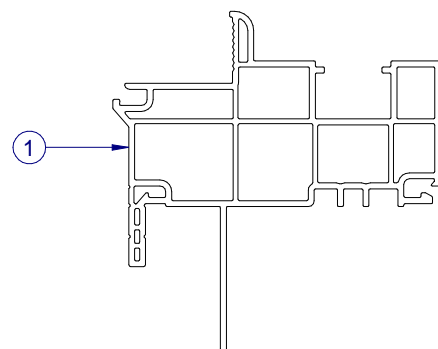

SECTION VIEW C-C  
ALTERNATE FIN FRAME  
(SCALE 1:2)

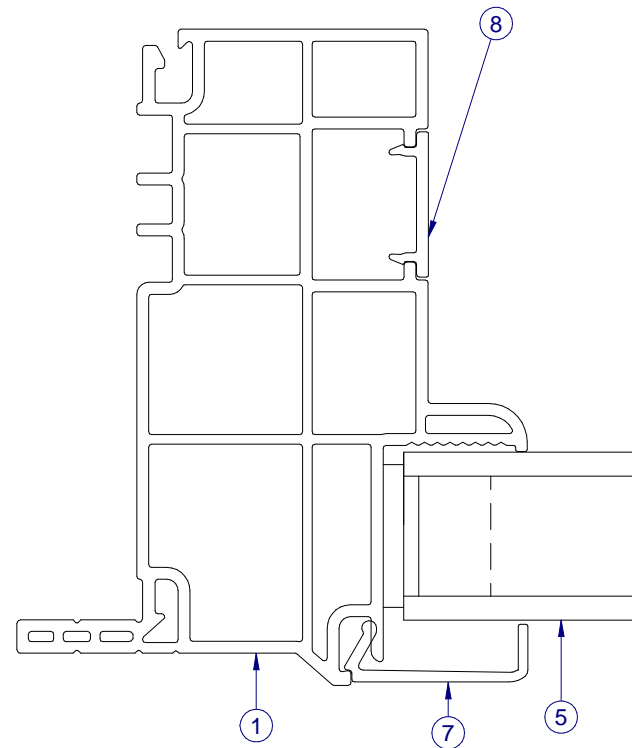

SECTION VIEW B-B

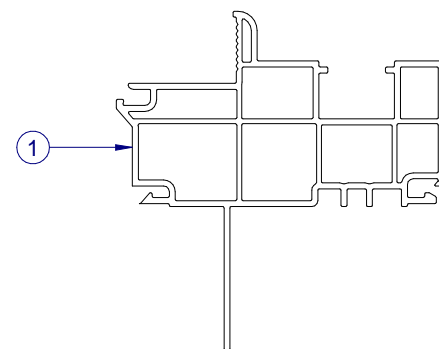

SECTION VIEW C-C  
ALTERNATE FIN ONLY FRAME  
(SCALE 1:2)

INTERIOR

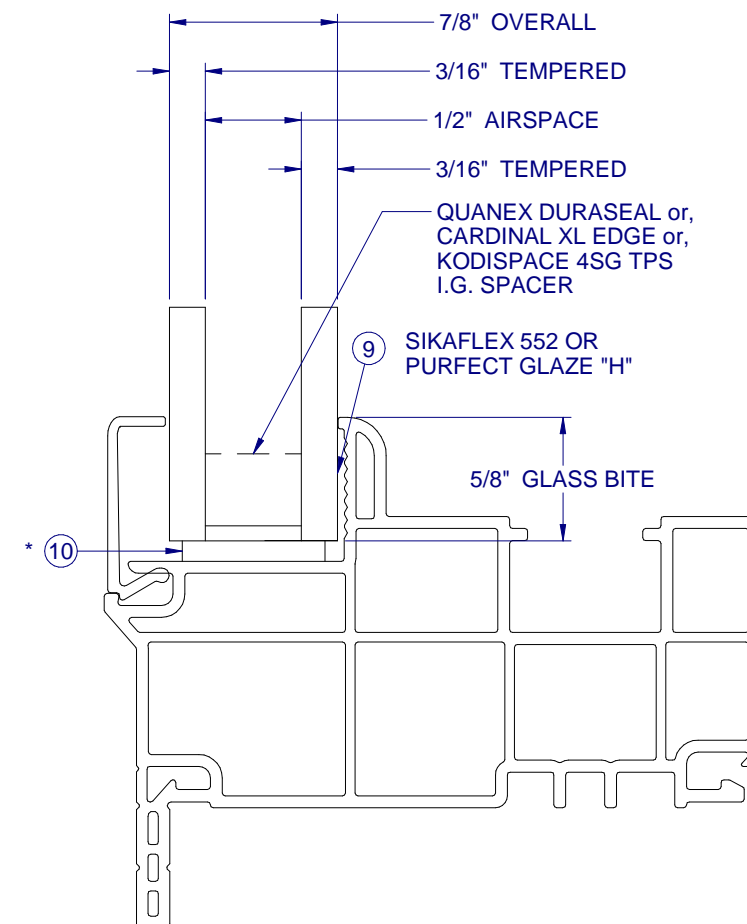
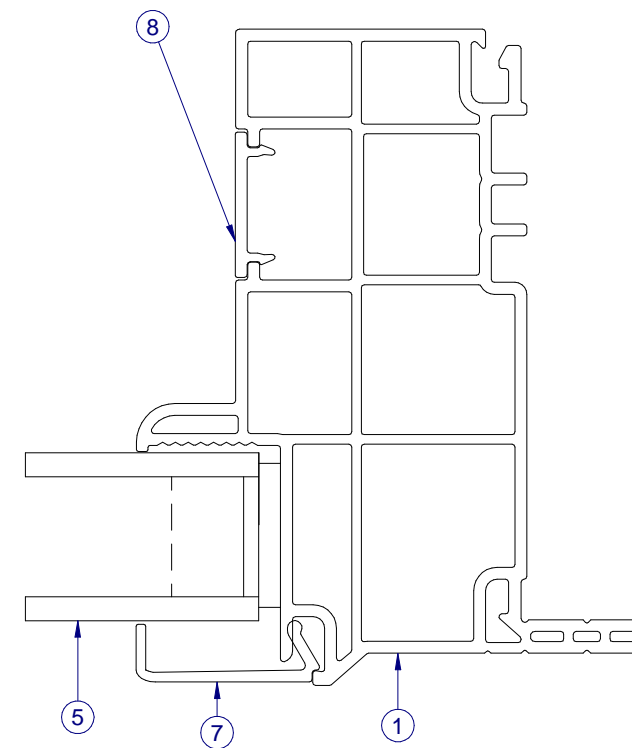

GLASS TYPE A  
1:1

\* SETTING BLOCKS PER FBC 2411.3.3.1

"O" CONFIGURATION DESIGN PRESSURES, PSF  
(POSITIVE AND NEGATIVE PRESSURES ARE EQUAL)

	GLASS TYPE	WINDOW SHORT DIMENSION, UNIT SIZE (IN.)						
		18	24	30	36	42	48	
WINDOW LONG DIMENSION, UNIT SIZE (IN.)	54	A	75.0	75.0	75.0	75.0	65.3	50.0
	60	A	75.0	75.0	75.0	75.0	65.3	50.0
	66	A	75.0	75.0	75.0	75.0	65.3	50.0
	72	A	75.0	75.0	75.0	75.0	65.3	50.0
	78	A	75.0	75.0	75.0	75.0	65.3	50.0
	84	A	75.0	75.0	75.0	75.0	65.3	50.0
	90	A	75.0	75.0	75.0	75.0	65.3	50.0
	96	A	75.0	75.0	75.0	75.0	65.3	50.0
	102	A	75.0	75.0	75.0	75.0	65.3	50.0
	108	A	75.0	75.0	75.0	71.1	63.1	50.0
114	A	75.0	75.0	75.0	66.7	59.0	50.0	
120	A	75.0	75.0	73.1	62.7	55.4	50.0	

ITEM	PART #	DESCRIPTION	MATERIAL
1	H-6128	MAIN FRAME, FLANGE, HEAD	PVC
5	GLASS	SEE SHEET 3	
7	S-6141	GLAZING BEAD	PVC
8	S-6218	FRAME FILLER	PVC
9		PURFECT GLAZE "H", SIKAFLEX 552	
10	P-5612	Setting Block, .12 x 1 x 2	



1900 SW 44TH AVE.  
OCALA, FLORIDA 34474  
WWW.CWS.CC

**615 PVC  
PICTURE WINDOW  
NON-IMPACT**

**FRAME CORNER  
CONSTRUCTION**

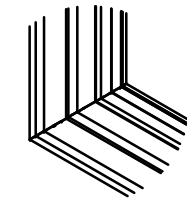

CORNER WELD  
(ALL SIDES)  
1:8

PROPRIETARY AND CONFIDENTIAL  
THE INFORMATION CONTAINED IN  
THIS DRAWING IS THE SOLE  
PROPERTY OF CUSTOM WINDOW  
SYSTEMS, INC. ANY  
REPRODUCTION IN PART OR AS A  
WHOLE WITHOUT THE WRITTEN  
PERMISSION OF CUSTOM WINDOW  
SYSTEMS, INC IS PROHIBITED.

FLORIDA APPROVAL NO.:  
18147



9/13/2023

LUCAS A. TURNER, P.E.  
FL PE # 58201  
Turner Engineering &  
Consulting, Inc.  
2428 Old Natchez Trc Trl  
Camden, TN 38320  
PH. 941-380-1574

SHEET DESCRIPTION:  
**DP CHART, BOM AND  
EXTRUSIONS**

DRAWN BY: MCS	DATE: 8/31/2023
DWG #: CWS-1112	REV.: C
SCALE: 1:1	SHEET 4 OF 6

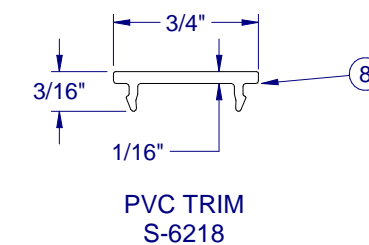
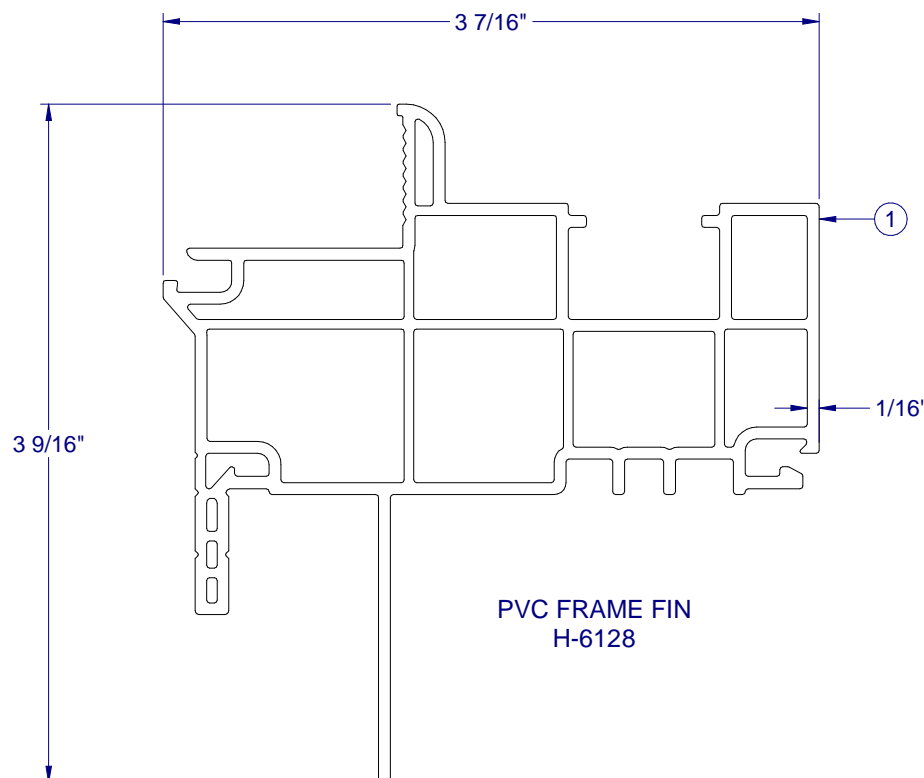
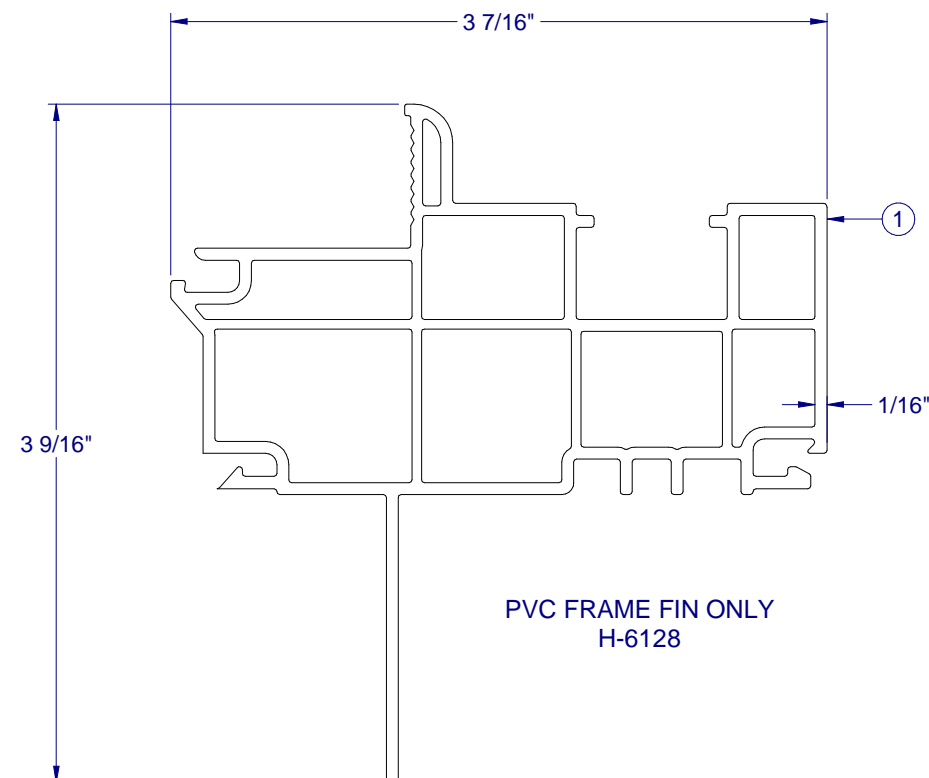
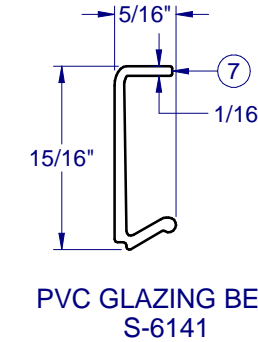
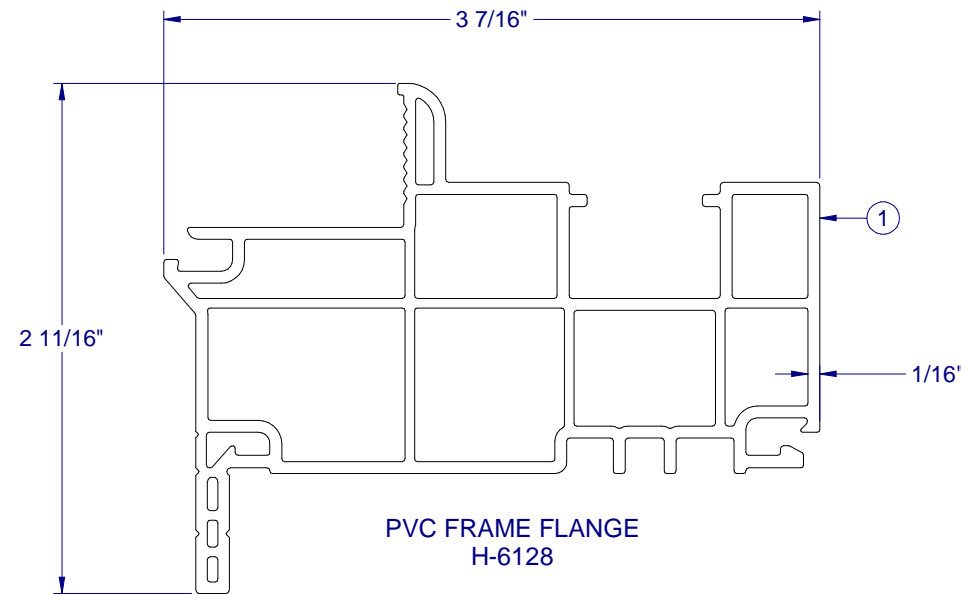

NOTE: IF SIZE INTENDED IS NOT SHOWN, USE NEXT LARGER SIZE.



1900 SW 44TH AVE.  
OCALA, FLORIDA 34474  
WWW.CWS.CC

**615 PVC  
PICTURE WINDOW  
NON-IMPACT**

PROPRIETARY AND CONFIDENTIAL  
THE INFORMATION CONTAINED IN  
THIS DRAWING IS THE SOLE  
PROPERTY OF CUSTOM WINDOW  
SYSTEMS, INC. ANY  
REPRODUCTION IN PART OR AS A  
WHOLE WITHOUT THE WRITTEN  
PERMISSION OF CUSTOM WINDOW  
SYSTEMS, INC IS PROHIBITED.

FLORIDA APPROVAL NO.:  
18147

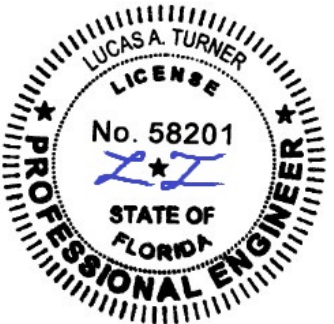

9/13/2023

LUCAS A. TURNER, P.E.  
FL PE # 58201  
Turner Engineering &  
Consulting, Inc.  
2428 Old Natchez Trc Trl  
Camden, TN 38320  
PH. 941-380-1574

SHEET DESCRIPTION:

**ANCHOR SCHEDULE AND  
NOTES**

DRAWN BY:	DATE:
MCS	8/31/2023
DWG #:	REV.:
CWS-1112	C
SCALE:	SHEET
1:25	5 OF 6

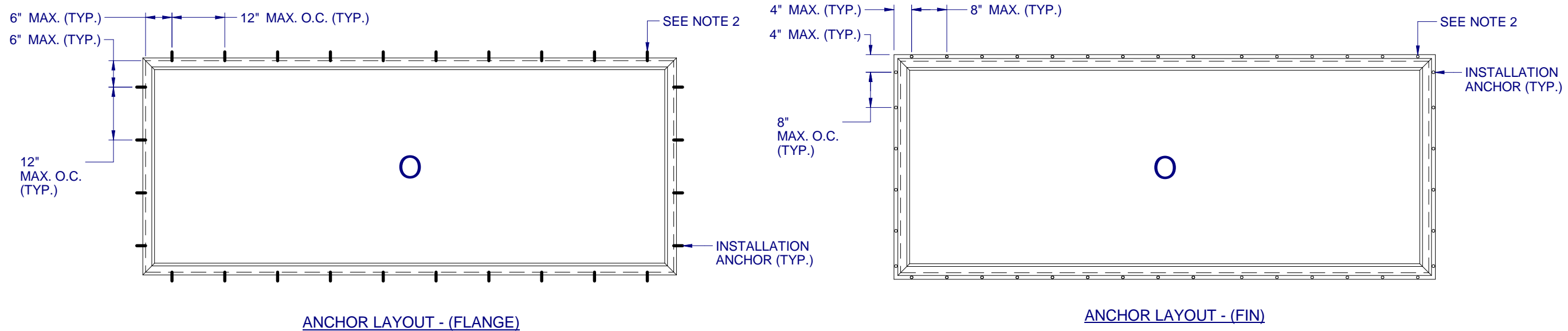

NOTES:

1. INSTALL ONE ANCHOR AT EACH INSTALLATION LOCATION. ANCHOR SPACING APPLIES TO ALL SHAPES (SEE SHEET 2) ALONG ALL FRAME EDGES. SILL ANCHOR SPACING SAME AS HEAD.
2. SHIM AS REQ AT EACH INSTALLATION ANCHOR USING LOAD BEARING SHIMS. MAX. ALLOWABLE SHIM STACK TO BE 1/4". USE SHIMS WHERE SPACE GREATER THAN 1/16" IS PRESENT. LOAD BEARING SHIMS SHALL BE CONSTRUCTED OF HIGH DENSITY PLASTIC OR BETTER. WOOD SHIMS ARE NOT ALLOWED.
3. ANCHOR TYPE, SIZE, SPACING AND EMBEDMENT SHALL BE AS SPECIFIED IN THESE DRAWINGS, SEE TABLE 1, SHEET 6.
4. ALL INSTALLATION ANCHORS MUST BE MADE OF OR PROTECTED WITH A CORROSION RESISTANT MATERIAL OR COATING. DISSIMILAR METALS OR MATERIALS IN CONTACT WITH PRESSURE TREATED WOOD MUST BE PROTECTED TO PREVENT REACTION.
5. INSTALLATION ANCHORS SHALL BE IN ACCORDANCE WITH ANCHOR MANUFACTURER'S INSTALLATION INSTRUCTIONS, AND ANCHORS SHALL NOT BE USED IN SUBSTRATES WITH STRENGTHS LESS THAN THE MINIMUM SPECIFIED IN TABLE 1, SHEET 6.
6. ANCHOR EMBEDMENT TO SUBSTRATE SHALL BE BEYOND WALL DRESSING OR STUCCO. FOR CONCRETE/CMU OPENINGS, EMBEDMENT SHALL BE BEYOND WOOD BUCKS, IF USED, INTO SUBSTRATE - 1X BUCKS ARE OPTIONAL.
7. A MINIMUM CENTER-TO-CENTER SPACING SHALL BE MAINTAINED BETWEEN ALL FASTENERS: 3" FOR MASONRY, 1" FOR WOOD AND METAL.
8. WOOD OR MASONRY OPENINGS, BUCKS AND BUCK FASTENERS SHALL BE PROPERLY DESIGNED BY THE ARCHITECT OR ENGINEER OF RECORD AND INSTALLED TO TRANSFER WIND LOADS TO THE STRUCTURE. SUBSTRATES SHALL MEET THE MINIMUM STRENGTH REQUIREMENTS AS SHOWN IN TABLE 1, SHEET 6. CONCRETE AND MASONRY SUBSTRATES MAY NOT BE CRACKED.
9. SEALING AND FLASHING STRATEGIES FOR OVERALL WATER RESISTANCE OF INSTALLATION SHALL BE DONE BY OTHERS FOLLOWING THE CURRENT VERSION OF THE REFERENCE DOCUMENTS: FMA/AAMA 100(FIN WINDOWS), FMA/AAMA 200(FLANGE WINDOWS), FMA/WDMA 250(BOX WINDOWS), FMA/AAMA/WDMA 300(EXTERIOR DOORS)



### 615 PVC PICTURE WINDOW NON-IMPACT

PROPRIETARY AND CONFIDENTIAL  
THE INFORMATION CONTAINED IN THIS DRAWING IS THE SOLE PROPERTY OF CUSTOM WINDOW SYSTEMS, INC. ANY REPRODUCTION IN PART OR AS A WHOLE WITHOUT THE WRITTEN PERMISSION OF CUSTOM WINDOW SYSTEMS, INC IS PROHIBITED.

FLORIDA APPROVAL NO.:  
18147



9/13/2023

LUCAS A. TURNER, P.E.  
FL PE # 58201  
Turner Engineering & Consulting, Inc.  
2428 Old Natchez Trc Trl  
Camden, TN 38320  
PH. 941-380-1574

SHEET DESCRIPTION:

#### INSTALLATION DETAILS

DRAWN BY:	DATE:
MCS	8/31/2023
DWG #:	REV.:
CWS-1112	C
SCALE:	SHEET
1:2	6 OF 6

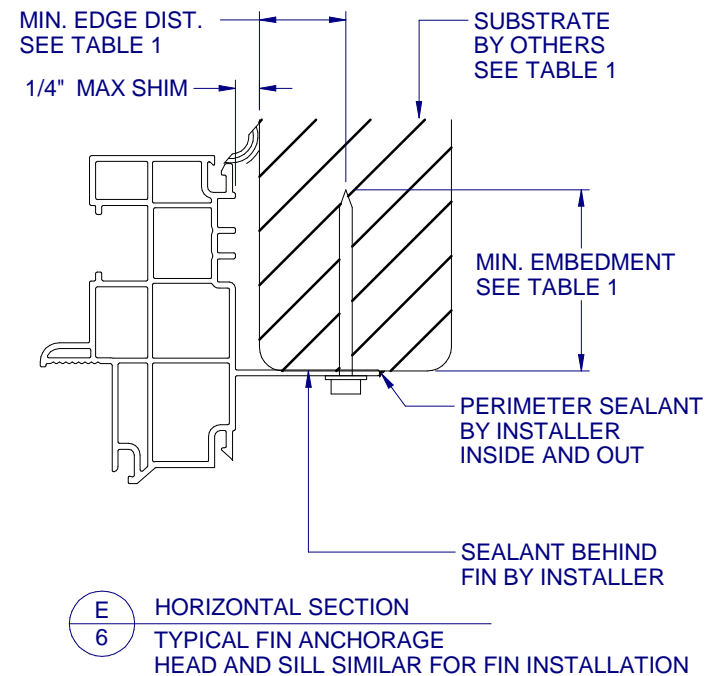
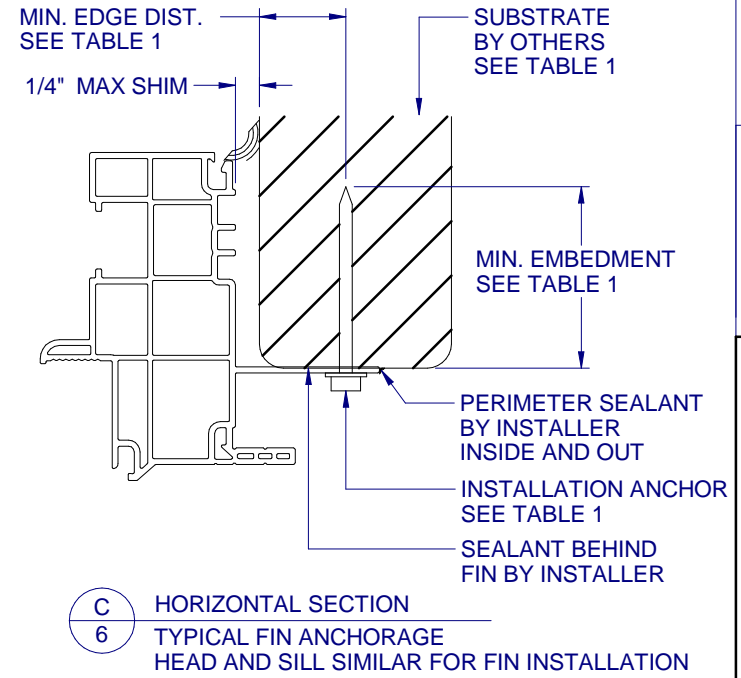
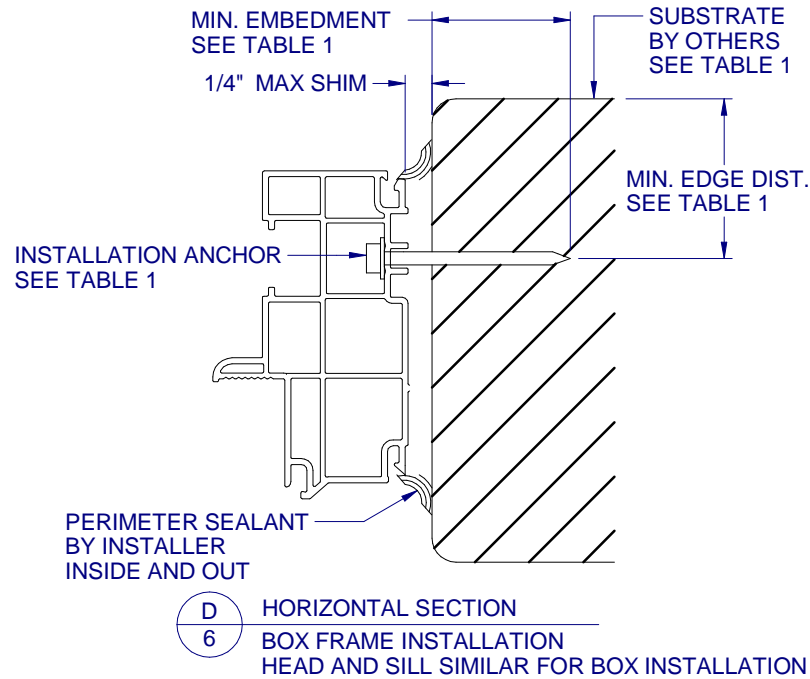
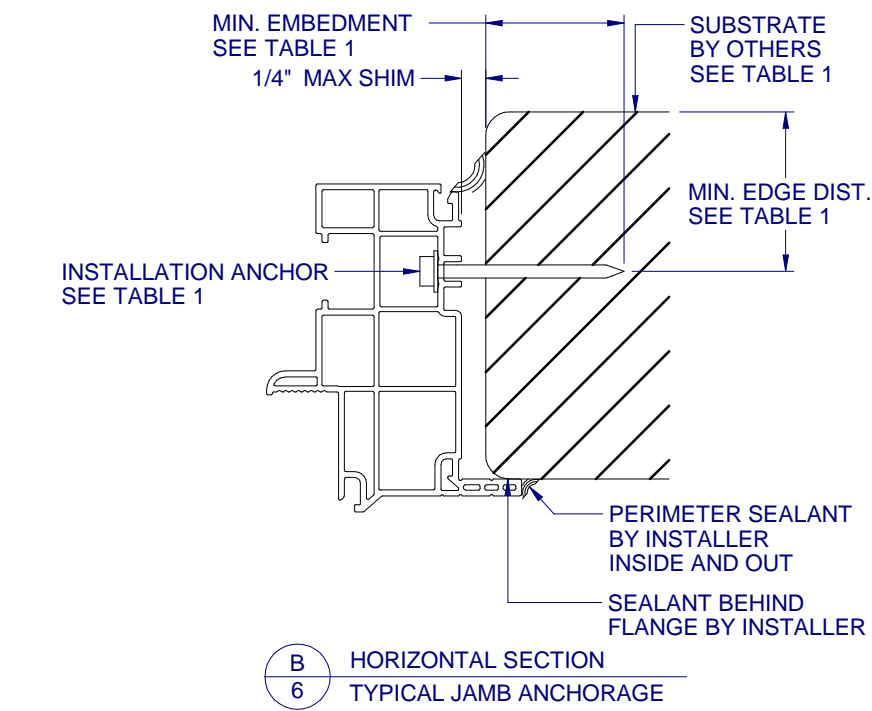
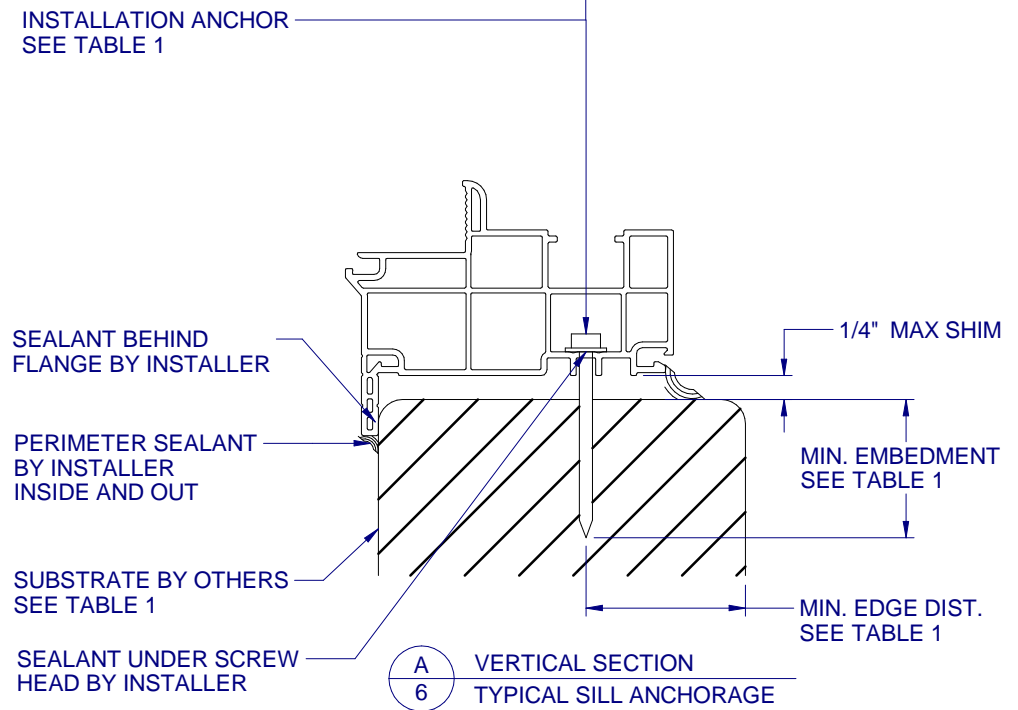
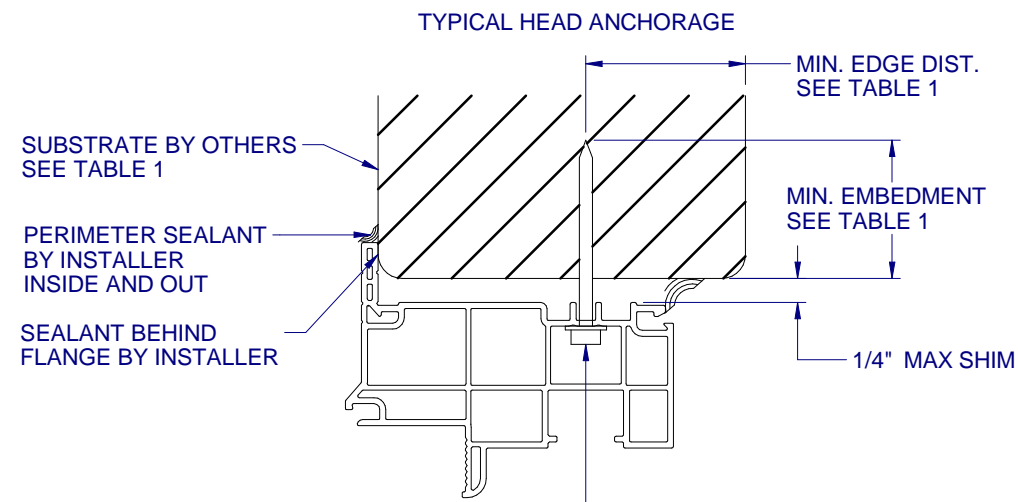

**TABLE 1: APPROVED INSTALLATION FASTENERS**

FRAME TYPE	SUBSTRATE TYPE	ANCHOR TYPE	MIN. EMBEDMENT	MIN. EDGE DIST.
FLANGE	CONCRETE (2.0 KSI MIN.)	3/16" ITW TAPCON	1-1/2"	1-1/8"
FLANGE	HOLLOW OR GROUT-FILLED CMU (117 PCF MIN.)	3/16" ITW TAPCON	1"	2"
FLANGE	CONCRETE (3.05 KSI MIN.)	3/16" DEWALT ULTRACON+	1-3/4"	1"
FLANGE	HOLLOW OR GROUT-FILLED CMU (ASTM C-90)	3/16" DEWALT ULTRACON+	1-1/4"	2-1/2"
FLANGE	2X MIN. SOUTHERN PINE (G=0.55)	3/16" ITW TAPCON OR DEWALT ULTRACON+	1-3/8"	7/8"
FLANGE	2X MIN. SOUTHERN PINE (G=0.55)	#10 WOOD SCREW	1-3/8"	7/8"
FLANGE	16 GAUGE (0.060") MIN. STEEL STUD (33 KSI YIELD MIN)	#10-16 HILTI KWIK-FLEX OR ITW TEKS SELF-DRILLING SCREW	FULL THREAD THRU 0.060"	7/16"
FLANGE	1/8" ALUM. (6063-T5 MIN.) OR 1/8" STEEL (33 KSI MIN.)	#10 GRADE 5 SELF-TAPPING / DRILLING SCREW	FULL THREAD THRU 0.125"	7/16"
FIN	2X MIN. SOUTHERN PINE (G=0.55)	#8 WOOD SCREW	1-1/2"	7/16"

FLANGE REMOVAL NOTE: PARTIALLY OR FULLY REMOVING THE FLANGE, UP TO AND INCLUDING A BOX-FRAME APPLICATION IS ACCEPTABLE PROVIDED:

- MIN. 1/4" FILLET OF CONSTRUCTION-GRADE ADHESIVE CAULK IS APPLIED INSIDE AND OUT, FULL PERIMETER, BY INSTALLER.
- PRODUCT ANCHORAGE IS IN ACCORDANCE WITH REQUIREMENTS AS SHOWN FOR FLANGE WINDOWS.