

# ALUMINUM ROOF PANELS

0.024" & 0.030" ALUMINUM 3" OLYMPIC RISERS AND  
0.027" & 0.040" ALUMINUM TWIN VEE CLEAR SPAN TABLES



**TABLE 1: 3" ALUMINUM OLYMPIC RISER PANEL**  
CLEAR SPANS BY ASD DESIGN PRESSURE

0.024" ALUMINUM PANEL				0.030" ALUMINUM PANEL			
MAXIMUM POSITIVE PRESSURE (ASD)	MAX PANEL CLEAR SPAN	MAXIMUM NEGATIVE PRESSURE (ASD)	MAX PANEL CLEAR SPAN	MAXIMUM POSITIVE PRESSURE (ASD)	MAX PANEL CLEAR SPAN	MAXIMUM NEGATIVE PRESSURE (ASD)	MAX PANEL CLEAR SPAN
+10 PSF	10' - 0"	-10 PSF	10' - 0"	+10 PSF	11' - 2"	-10 PSF	11' - 2"
+15 PSF	9' - 8"	-15 PSF	9' - 10"	+15 PSF	11' - 2"	-15 PSF	11' - 2"
+20 PSF	9' - 2"	-20 PSF	8' - 2"	+20 PSF	10' - 10"	-20 PSF	10' - 10"
+25 PSF	8' - 7"	-25 PSF	6' - 5"	+25 PSF	10' - 5"	-25 PSF	10' - 5"
+30 PSF	8' - 0"	-30 PSF	4' - 9"	+30 PSF	10' - 1"	-30 PSF	10' - 1"
+35 PSF	7' - 6"			+35 PSF	9' - 8"	-35 PSF	9' - 8"
+40 PSF	6' - 11"			+40 PSF	9' - 3"	-40 PSF	9' - 3"
+45 PSF	6' - 4"			+45 PSF	8' - 10"	-45 PSF	8' - 10"
+50 PSF	5' - 10"			+50 PSF	8' - 5"	-50 PSF	8' - 5"
+55 PSF	5' - 3"			+55 PSF	8' - 1"	-55 PSF	8' - 1"
+60 PSF	4' - 9"			+60 PSF	7' - 8"	-60 PSF	7' - 8"
				+65 PSF	7' - 3"		
				+70 PSF	6' - 10"		
				+75 PSF	6' - 5"		
				+80 PSF	6' - 1"		
				+85 PSF	5' - 8"		
				+90 PSF	5' - 3"		
				+95 PSF	4' - 10"		

**TABLE 3- SAMPLE ASD WIND PRESSURES FOR HOST ATTACHED CANOPY ROOF:**

**ROOF PRESSURES FOR OPEN -HOST ATTACHED**

WIND SPEED (MPH)	ASCE EXPOSURE CATEGORY	(PSF) hc/hc<0.9		(PSF) 0.9<hc/hc<1	
		(+)	(-)	(+)	(-)
120	B	11	-11	11	-17
	C	13	-13	13	-21
	D	16	-16	16	-25
130	B	13	-13	13	-20
	C	15	-15	15	-24
	D	18	-18	18	-29
140	B	15	-14	15	-23
	C	18	-17	18	-28
	D	21	-21	21	-34
150	B	17	-17	17	-26
	C	20	-20	20	-32
	D	24	-24	24	-39
160	B	19	-19	19	-30
	C	23	-23	23	-36
	D	28	-27	28	-44
170	B	21	-21	21	-34
	C	26	-26	26	-41
	D	31	-31	31	-49

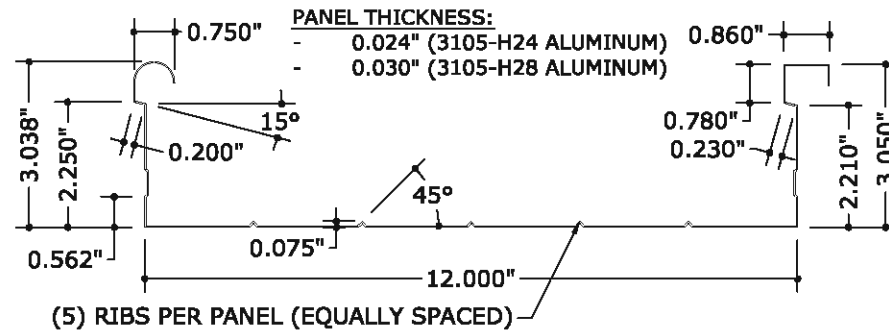

**1 3" METAL RISER PANELS**  
1 N.T.S. SECTION VIEW

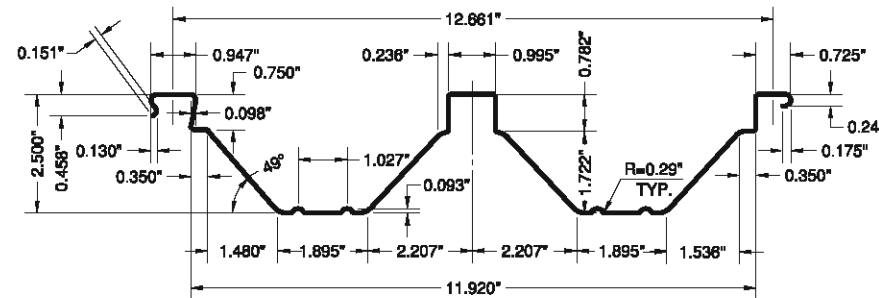

**2 2.5" TWIN VEE PANELS**  
1 N.T.S. SECTION VIEW

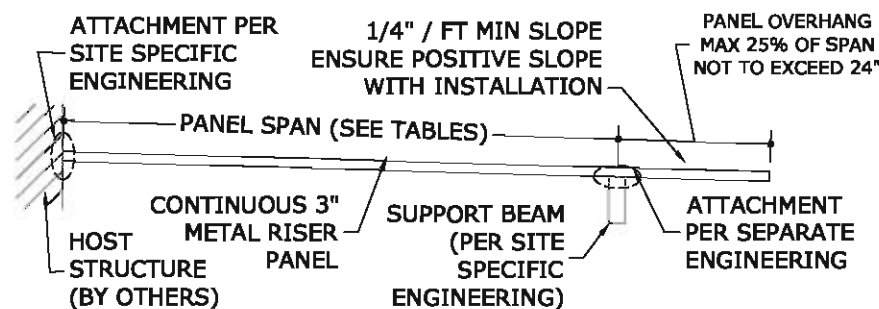

**3 3" METAL RISER ROOF PANELS**  
1 N.T.S. ELEVATION

**DESIGN NOTES**

1. THE DESIGN PRESSURE VALUES LISTED IN THE TABLES HEREIN ARE ALLOWABLE (ASD) PRESSURES. IF ULTIMATE DESIGN PRESSURES ARE REQUIRED, MULTIPLY THE ALLOWABLE DESIGN PRESSURES BY 1.67 (ULTIMATE PRESSURE = ALLOWABLE PRESSURE \* 1.67).
2. THIS PRODUCT IS APPROVED FOR NON-HABITABLE (CATEGORY I) STRUCTURES ONLY.
3. ALL ROOF PANEL SPANS LISTED HEREIN ASSUME A MAXIMUM DEFLECTION OF L/90.
4. LINEAR INTERPOLATION OF THE ROOF PANEL SPANS LISTED HEREIN IS PERMITTED.
6. DESIGN PRESSURES NOTED HEREIN ARE BASED ON MAXIMUM TESTED PRESSURES DIVIDED BY A 1.5 SAFETY FACTOR. IF A 2.0 SAFETY FACTOR IS REQUIRED BY LOCAL JURISDICTION, SPANS SHALL BE MULTIPLIED BY A REDUCTION FACTOR OF 0.66. FOR OPTIMIZED SPANS WITH A SAFETY FACTOR OF 2.0 OR GREATER, SITE SPECIFIC ENGINEERING IS REQUIRED.
7. A 300LB POINT LOAD HAS NOT BEEN CONSIDERED IN THESE CALCULATIONS DUE TO THE NATURE OF THE INTENDED APPLICATION. END USER SHALL BE NOTIFIED THAT PANELS ARE NOT DESIGNED FOR HUMAN LOADING.

**GENERAL NOTES**

1. THE SYSTEM DESCRIBED HEREIN HAS BEEN DESIGNED AND TESTED PER ASTM E330 (TEST REPORT #'S F7038.01-401-44-R0 & F7038.02-401-44-R0 BY ARCHITECTURAL TESTING, INC.) IN ACCORDANCE WITH THE FLORIDA BUILDING CODE, SEVENTH EDITION (2020), THE 2018 INTERNATIONAL BUILDING CODE (IBC) AND THE INTERNATIONAL RESIDENTIAL CODE (IRC). THESE METAL ROOF PANELS ARE ACCEPTABLE FOR ALL AREAS AS DEFINED BY THE TEXAS DEPARTMENT OF INSURANCE.
2. NO 33-1/3% INCREASE IN ALLOWABLE STRESS HAS BEEN USED IN THE DESIGN OF THIS SYSTEM.
3. SITE SPECIFIC POSITIVE AND NEGATIVE DESIGN PRESSURES CALCULATED FOR USE WITH THIS SYSTEM SHALL BE DETERMINED SEPARATELY PER ASCE 7 AND THE REFERENCED BUILDING CODE. DESIGN PRESSURES MUST BE LESS THAN OR EQUAL TO THE POSITIVE AND NEGATIVE DESIGN PRESSURES LISTED HEREIN.
4. THE SYSTEM DETAILED HEREIN IS GENERIC AND DOES NOT PROVIDE INFORMATION FOR A SPECIFIC SITE. FOR SITE CONDITIONS DIFFERENT FROM THE CONDITIONS DETAILED HEREIN, A LICENSED ENGINEER OR REGISTERED ARCHITECT SHALL PREPARE SITE SPECIFIC DOCUMENTS FOR USE IN CONJUNCTION WITH THIS DOCUMENT.
5. THESE INSTALLATION INSTRUCTIONS ARE PART OF A PRODUCT APPROVAL EVALUATION AND SHALL ONLY BE USED IN CONJUNCTION WITH THE EVALUATION REPORT SUBMITTED FOR THE SAME PRODUCT APPROVAL.
6. PERMIT HOLDER SHALL VERIFY THE ADEQUACY OF THE EXISTING STRUCTURE TO WITHSTAND SUPERIMPOSED LOADS. BRICK VENEER PER ASTM C62 (BY OTHERS) SHALL BE ANCHORED PROPERLY TO TRANSFER ANY APPLICABLE LOADS TO THE EXISTING HOST STRUCTURE.
7. ALUMINUM RISER PANELS SHALL BE 3105-H24 (FOR 0.024" & 0.027" THICK PANELS) AND 3105-H28 (FOR 0.030" & 0.040" THICK PANELS) OR EQUIVALENT ALUMINUM ALLOY.
8. ALL PANEL ATTACHMENTS SHALL BE CERTIFIED PER SEPARATE ENGINEERING ON A SITE SPECIFIC BASIS.
9. CONTRACTOR IS RESPONSIBLE TO INSULATE OR PROTECT ALL MEMBERS FROM DISSIMILAR MATERIALS TO PREVENT ELECTROLYSIS.
10. THE CONTRACTOR IS RESPONSIBLE FOR WATER/WEATHER PROOFING MATERIALS AND INSTALLATION SUCH AS FLASHING, CAULKING, ETC.

**TABLE 2: ALUMINUM TWIN VEE PANEL**  
CLEAR SPANS BY ASD DESIGN PRESSURE

0.027" ALUMINUM PANEL				0.040" ALUMINUM PANEL			
MAXIMUM POSITIVE PRESSURE (ASD)	MAX PANEL CLEAR SPAN	MAXIMUM NEGATIVE PRESSURE (ASD)	MAX PANEL CLEAR SPAN	MAXIMUM POSITIVE PRESSURE (ASD)	MAX PANEL CLEAR SPAN	MAXIMUM NEGATIVE PRESSURE (ASD)	MAX PANEL CLEAR SPAN
+10 PSF	11' - 2"	-10 PSF	8' - 5"	+10 PSF	11' - 2"	-10 PSF	11' - 2"
+15 PSF	10' - 10"	-15 PSF	6' - 10"	+15 PSF	11' - 2"	-15 PSF	10' - 3"
+20 PSF	9' - 4"	-20 PSF	5' - 11"	+20 PSF	11' - 2"	-20 PSF	8' - 10"
+25 PSF	8' - 4"	-25 PSF	5' - 4"	+25 PSF	11' - 2"	-25 PSF	7' - 11"
+30 PSF	7' - 8"	-30 PSF	4' - 10"	+30 PSF	11' - 2"	-30 PSF	7' - 3"
+35 PSF	7' - 1"	-35 PSF	4' - 6"	+35 PSF	10' - 4"	-35 PSF	6' - 8"
+40 PSF	6' - 7"	-40 PSF	4' - 2"	+40 PSF	9' - 8"	-40 PSF	6' - 3"
+45 PSF	6' - 3"	-45 PSF	3' - 11"	+45 PSF	9' - 1"	-45 PSF	5' - 11"
+50 PSF	5' - 11"	-50 PSF	3' - 9"	+50 PSF	8' - 7"	-50 PSF	5' - 7"
+55 PSF	5' - 8"	-55 PSF	3' - 7"	+55 PSF	8' - 3"	-55 PSF	5' - 4"
+60 PSF	5' - 5"	-60 PSF	3' - 5"	+60 PSF	7' - 10"	-60 PSF	5' - 1"
+65 PSF	5' - 2"			+65 PSF	7' - 7"		
+70 PSF	5' - 0"			+70 PSF	7' - 3"		
+75 PSF	4' - 10"			+75 PSF	7' - 0"		
+80 PSF	4' - 8"			+80 PSF	6' - 10"		
+85 PSF	4' - 6"			+85 PSF	6' - 7"		
+90 PSF	4' - 5"			+90 PSF	6' - 5"		

**FOR TABLE 3**

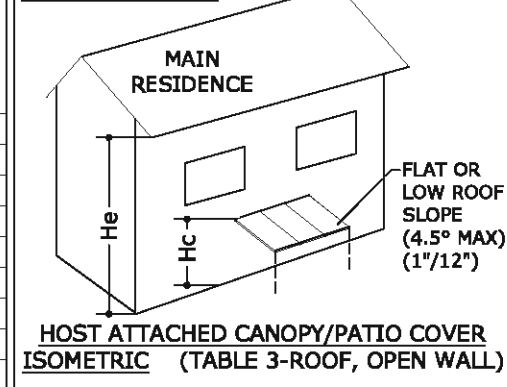

- SAMPLE WIND PRESSURE TABLE NOTES:**
- TABLE 3 PROVIDES SAMPLE ASD WIND PRESSURES FOR HOST-ATTACHED, OPEN CANOPY ROOFS USING THE ASCE 7-16 ATTACHED CANOPY METHODOLOGY (REFER DIAGRAM).
  - ALTERNATE CONSTRUCTION OR LOAD COMBINATIONS REQUIRE CERTIFIED SITE-SPECIFIC CALCULATIONS.
  - SNOW / SNOW DRIFT TO BE CONSIDERED FOR WORST CASE LOADING CRITERIA
  - VISIT [ECALC.IO/WIND](http://ECALC.IO/WIND) FOR ADDITIONAL WIND SPEED TO WIND PRESSURE CALCULATIONS & CERTIFICATION

**SPAN TABLE NOTES:**

1. THE SPANS LISTED HEREIN ARE APPLICABLE FOR NON-HABITABLE "OPEN" AND "SCREENED" ROOFS ONLY.
2. POSITIVE AND NEGATIVE DESIGN PRESSURE SHALL BE DETERMINED SEPARATELY PER ASCE 7 BASED ON SITE SPECIFIC APPLICATION AND COMPARED TO THE APPLICABLE TABLE ABOVE. THE LIMITING POSITIVE OR NEGATIVE PRESSURE SPAN VALUE SHALL BE USED FOR INSTALLATION.
3. ROOF PANEL ATTACHMENTS SHALL BE CERTIFIED ON A SITE SPECIFIC BASIS
4. MAXIMUM PANEL OVERHANGS SHALL BE AS FOLLOWS:
  - OVERHANG FOR DESIGN PRESSURES ABOVE +/- 45 PSF = 12.0" MAXIMUM AND LIMITED TO 25% OF CLEAR SPAN

DRWN	CHKD	DATE
CCB	RWN	9/29/20

REMARKS  
2020 FBC

THIS DOCUMENT IS THE PROPERTY OF ENGINEERING EXPRESS, AND SHALL NOT BE REPRODUCED IN WHOLE OR PART WITHOUT WRITTEN CONSENT OF ENGINEERING EXPRESS. ALTERATIONS, ADDITIONS, OR OTHER MARKINGS TO THIS DOCUMENT ARE NOT PERMITTED AND INVALIDATE OUR CERTIFICATION.

COPYRIGHT ENGINEERING EXPRESS®

VISIT [ECALC.IO/32093](http://ECALC.IO/32093)

FOR SITE SPECIFIC DEVIATIONS & MORE INFORMATION ABOUT THIS DOCUMENT OR SCAN THIS QR CODE  
VISIT [ENGINEERINGEXPRESS.COM/FOURSEASONS](http://ENGINEERINGEXPRESS.COM/FOURSEASONS) FOR ADDITIONAL PLANS, REPORTS & RESOURCES

