

# TRANE TECHNOLOGIES

AMERICAN STANDARD CONDENSER (ROOF MOUNTED)

VALID FOR USE INSIDE AND OUTSIDE THE HVHZ (SEE LIMITATIONS HEREIN)

NON-SITE-SPECIFIC STRUCTURAL PERFORMANCE EVALUATION. A DESIGN PROFESSIONAL SHALL BE RESPONSIBLE FOR CERTIFYING THE APPLICATION OF THIS INFORMATION TO ANY SITE-SPECIFIC LOCATION.

NOTE: THIS EVALUATION CERTIFIES BOTH UNIT INTEGRITY AND ANCHORAGE TO HOST STRUCTURE FOR WIND RESISTANCE (FOR ROOFTOP USE ONLY). SEE LIMITATIONS HEREIN.

FRANK BENNARDO, P.E.  
PE# 0046549 CA# 9885

FEBRUARY 19, 2024

**NOTE REGARDING USE OF THIS DOCUMENT & USE OUTSIDE FLORIDA:**

NON-SITE-SPECIFIC STRUCTURAL PERFORMANCE EVALUATION. THIS PRODUCT EVALUATION IS VALID FOR USE IN **FLORIDA ONLY**. USE OF THIS EVALUATION REQUIRES A REVIEW & CERTIFICATION BY A LOCAL DESIGN PROFESSIONAL WHO SHALL BE RESPONSIBLE FOR THE PROPER ADAPTATION OF THIS GENERAL PERFORMANCE EVALUATION TO ANY SITE-SPECIFIC PROJECT. CONTACT THIS OFFICE AT **ENGINEERINGEXPRESS.COM/QUOTE** FOR ASSISTANCE WITH YOUR PROJECT-SPECIFIC NEEDS & FOR ADAPTATION & CERTIFICATION OF THIS DOCUMENT OUTSIDE OF FLORIDA.

FL 19588.2



POSTAL ADDRESS:  
2234 NORTH FEDERAL HWY # 7664  
BOCA RATON, FL 33431  
ENGINEERINGEXPRESS.COM

## GENERAL NOTES

- THIS SYSTEM HAS BEEN DESIGNED AND SHALL BE FABRICATED IN ACCORDANCE WITH THE REQUIREMENTS OF THE FLORIDA BUILDING CODE EIGHTH EDITION (2023) & ASCE 7-22. THIS SYSTEM MAY BE USED WITHIN AND OUTSIDE THE HIGH VELOCITY HURRICANE ZONE (HVHZ). REQUIRED DESIGN PRESSURES SHALL BE FOUND ON A SITE SPECIFIC BASIS FOR USE WITH THE ALLOWABLE LOADS LISTED HEREIN. THIS DESIGN IS NOT INTENDED TO CERTIFY IMPACT RESISTANCE OF THE MECHANICAL UNIT CABINTRY.
- DESIGN & CERTIFICATION OF THE UNIT CABINTRY IS APPROVED THROUGH TEST REPORT#0708.01-15 BY AMERICAN TEST LAB OF SOUTH FLORIDA. DESIGN PRESSURES NOTED HEREIN ARE BASED ON MAXIMUM TESTED PRESSURES DIVIDED BY 1.5 SAFETY FACTOR. PRESSURE VALUES IN THIS APPROVAL ARE (ASD) ALLOWABLE DESIGN PRESSURES UNLESS NOTED OTHERWISE.
- BASEPAN MATERIAL CHOPPED FIBER LAMINATE W/ Fy=15 KSI. PLASTIC COMPONENTS USED WITHIN THE HVHZ MUST MEET ALL APPLICABLE FIRE/SMOKE/UV PERFORMANCE REQUIREMENTS AS SET FORTH IN THE ABOVE-NOTED BUILDING CODE.
- ALL SUPPORTING FRAMES SHOWN HEREIN SHALL BE BY OTHERS AND IS NOT PART OF THIS CERTIFICATION. A MINIMUM 0.087" THICK ALUMINUM (6063-T6 MIN.) OR STEEL (Fy=33 KSI MIN.) FLANGE IS REQUIRED. **ADDITIONALLY A 1"x3"x1/8" REINFORCEMENT PLATE SHALL BE USED AT THE UNDERSIDE OF THE FLANGE FOR AN OVERALL FLANGE THICKNESS OF 0.337" MIN.**
- ALL DIMENSIONS AND THE MINIMUM WEIGHT OF MECHANICAL UNIT SHALL CONFORM TO LIMITATIONS STATED HEREIN. ALL MECHANICAL SPECIFICATIONS (CLEAR SPACE, TONNAGE, ETC.) SHALL BE AS PER MANUFACTURER RECOMMENDATIONS AND ARE THE EXPRESS RESPONSIBILITY OF THE CONTRACTOR.
- ALL SHEET METAL SCREWS USED TO FASTEN BRACKETS TO MECHANICAL UNITS SHALL BE #10 (16 MIN THREADS PER INCH) ASTM F593 410 STAINLESS STEEL OR EQUIVALENT ONLY. BOLTS USED TO FASTEN ALUMINUM ANGLES TO SUPPORTING FRAME (BY OTHERS) SHALL BE ASTM F593 410 STAINLESS STEEL OR EQUIVALENT AND SHALL UTILIZE SAE GRADE WASHERS & NUTS. PROVIDE (5) PITCHES MINIMUM PAST THE THREAD PLANE FOR SHEET METAL SCREWS. ALL FASTENERS SHALL HAVE APPROPRIATE CORROSION PROTECTION TO PREVENT ELECTROLYSIS. ALL FASTENER CONNECTIONS TO ALUMINUM SHALL PROVIDE 2xDIAMETER EDGE DISTANCE.
- FASTENERS SHALL BE CADMIUM-PLATED OR OTHERWISE CORROSION-RESISTANT MATERIAL AND SHALL COMPLY WITH "SPECIFICATIONS FOR ALUMINUM STRUCTURES" SECTION J.3.7.2 BY THE ALUMINUM ASSOCIATION INC., AND ANY APPLICABLE FEDERAL, STATE AND OR LOCAL CODES. REFER TO FASTENER MANUFACTURER'S PUBLISHED DATA SHEETS AND RECOMMENDATIONS FOR FASTENER INSTALLATION INSTRUCTIONS.
- ALL CONCRETE SPECIFIED HEREIN IS NOT PART OF THIS CERTIFICATION. AS A MINIMUM, ALL CONCRETE SHALL BE STRUCTURAL CONCRETE 4" MIN. THICK AND SHALL HAVE MINIMUM COMPRESSIVE STRENGTH OF 3000 PSI, UNLESS NOTED OTHERWISE.
- THE CONTRACTOR IS RESPONSIBLE TO INSULATE ALL MEMBERS FROM DISSIMILAR MATERIALS TO PREVENT ELECTROLYSIS.
- ELECTRICAL GROUND, WHEN REQUIRED, TO BE DESIGNED & INSTALLED BY OTHERS.
- THE ADEQUACY OF ANY EXISTING STRUCTURE TO WITHSTAND SUPERIMPOSED LOADS SHALL BE VERIFIED BY THE ONSITE DESIGN PROFESSIONAL AND IS NOT INCLUDED IN THIS CERTIFICATION. THE SYSTEM DETAILED HEREIN IS GENERIC AND DOES NOT PROVIDE INFORMATION FOR A SPECIFIC SITE. FOR SITE CONDITIONS DIFFERENT FROM THE CONDITIONS DETAILED HEREIN, A LICENSED ENGINEER OR REGISTERED ARCHITECT SHALL PREPARE SITE-SPECIFIC DOCUMENTS FOR USE IN CONJUNCTION WITH THIS DOCUMENT.
- WATER-TIGHTNESS OF EXISTING HOST SUBSTRATE SHALL BE THE FULL RESPONSIBILITY OF THE INSTALLING CONTRACTOR. CONTRACTOR SHALL ENSURE THAT ANY REMOVED OR ALTERED WATERPROOFING MEMBRANE IS RESTORED AFTER FABRICATION AND INSTALLATION OF STRUCTURE PROPOSED HEREIN. THIS ENGINEER SHALL NOT BE RESPONSIBLE FOR ANY WATERPROOFING OR LEAKAGE ISSUES WHICH MAY OCCUR AS WATER-TIGHTNESS SHALL BE THE FULL RESPONSIBILITY OF THE INSTALLING CONTRACTOR.
- ENGINEER SEAL AFFIXED HERETO VALIDATE STRUCTURAL DESIGN AS SHOWN ONLY. USE OF THIS SPECIFICATION BY CONTRACTOR, et. al. INDEMNIFIES & SAVES HARMLESS THIS ENGINEER FOR ALL COST & DAMAGES INCLUDING LEGAL FEES & APPELLATE FEES RESULTING FROM MATERIAL FABRICATION, SYSTEM ERECTION, & CONSTRUCTION PRACTICES BEYOND THAT WHICH IS CALLED FOR BY LOCAL, STATE & FEDERAL CODES & FROM DEVIATIONS OF THIS PLAN.
- EXCEPT AS EXPRESSLY PROVIDED HEREIN, NO ADDITIONAL CERTIFICATIONS OR AFFIRMATIONS ARE INTENDED.
- ALTERATIONS, ADDITIONS, AND OTHER MARKINGS TO THIS DOCUMENT ARE NOT PERMITTED AND INVALIDATE THIS CERTIFICATION.

## TERMINOLOGY:

THE FOLLOWING ABBREVIATIONS MAY APPEAR IN THIS APPROVAL:

"ADDTL." FOR "ADDITIONAL", "AHJ" FOR "AUTHORITY HAVING JURISDICTION", "ALUM" FOR "ALUMINUM", "ASD" FOR "ALLOWABLE STRESS DESIGN", "BO" FOR "BUILD-OUT", "CS" FOR "CARBON STEEL", "EA." FOR "EACH", "E.D."/"EDGE"/"EDGE DIST." FOR "EDGE DISTANCE", "ELEV" FOR "ELEVATION", "EMBED" FOR "EMBEDMENT", "EQ"/"EQUIV." FOR "EQUIVALENT", "EXT" FOR "EXTERIOR", "FBC" FOR "FLORIDA BUILDING CODE", "ft" OR " ' " FOR "FEET", "G" FOR "SPECIFIC GRAVITY", "GA" FOR "GAUGE", "GALV" FOR "GALVANIZED", "GFB" FOR "GROUT-FILLED BLOCK", "GR" FOR "GRADE", "HOLLOW" FOR "HOLLOW BLOCK", "HORIZ" FOR "HORIZONTAL", "HVHZ" FOR "HIGH-VELOCITY HURRICANE ZONE", "in" OR " ' " FOR "INCHES", "INT" FOR "INTERIOR", "KSI" FOR "1,000 lb / in<sup>2</sup>", "L" FOR "LENGTH", "LB" FOR "POUND", "MAX" FOR "MAXIMUM", "MIN" FOR "MINIMUM", "N.T.S." FOR "NOT TO SCALE", "O.C." FOR "ON-CENTER", "P.E." FOR "PROFESSIONAL ENGINEER", "PERP" FOR "PERPENDICULAR", "PSF" FOR "POUNDS PER SQUARE FOOT (lb/ft<sup>2</sup>)", "PSI" FOR "POUNDS PER SQUARE INCH (lb/in<sup>2</sup>)", "QTY" FOR "QUANTITY", "REF." FOR "REFERENCE", "SCHED." FOR "SCHEDULE", "SDS" FOR "SELF-DRILLING SCREWS", "SMS" FOR "SHEET METAL SCREWS", "SPECS" FOR "SPECIFICATIONS", "SS" FOR "STAINLESS STEEL", "SUB" FOR "SUBMITTAL", "TAS" FOR "TESTING APPLICATION STANDARD", "TYP." FOR "TYPICAL", "ULT" FOR "ULTIMATE LOADS", "U.N.O." FOR "UNLESS NOTED OTHERWISE", "UTS" OR "Fu" FOR "ULTIMATE TENSILE STRENGTH/STRESS", "VERT" FOR "VERTICAL", "WLL" FOR "WORKING LOAD LIMIT", "W/" FOR "WITH", "W/O" FOR "WITHOUT", "YS" FOR "YIELD STRENGTH", "#" FOR "NUMBER", "&" FOR "AND", AND "Ø" FOR "DIAMETER".

VISIT [ECALC.IO/GLOSSARY](https://ecalculator.com) OR CONTACT ENGINEERING EXPRESS FOR ADDITIONAL ABBREVIATION/TERMINOLOGY CLARIFICATIONS.

## TRANE TECHNOLOGIES

6200 TROUP HWY  
TYLER, TX 75707  
PHONE: (903) 730-4602

AMERICAN STANDARD CONDENSER (ROOF MOUNTED)  
FLORIDA BUILDING CODE EIGHTH EDITION (2023)  
FLORIDA STATEWIDE APPROVAL (FSA)

REMARKS	DRWN	CHKD	DATE
PREV. SUBMITTAL (20-28639)	CCB	FLB	11/19/21
2023 FBC UPDATE	EPR	RWN	10/23/23
ADD MODELS	EPR	EPR	02/19/24

COPYRIGHT ENGINEERING EXPRESS®

23-68286

SCALE: NTS UNLESS NOTED

1 OF 3

NOTE: SEE NEXT PAGE FOR PRODUCT INSTALLATION DETAILS AND ANCHOR SCHEDULE TABLE.

### VISIT [ECALC.IO/TRANE](https://ecalculator.com)

FOR SITE-SPECIFIC DEVIATIONS & MORE INFORMATION ABOUT THIS DOCUMENT OR SCAN THIS QR CODE

VISIT [ENGINEERINGEXPRESS.COM/STORE](https://engineeringexpress.com/store) FOR ADDITIONAL PLANS, REPORTS & RESOURCES



c:\users\eric\engineering express\production - documents\projects\23-133-68286 2023 fbc update american standard condenser-roof mounted-steel tie-down clip system\work\2023 fbc\drawings & cad\23-68286g - cad\23-68286g - fl19588.2 - dwg2.dwg

2/19/2024 10:24 PM ERIC

c:\users\eric\engineering\_express\production - documents\projects\23-123-68286\2023 fbc update american standard condenser-roof mounted-steel tie-down clip system\work\2023 fbc\drawings & cad\23-68286g - fl19588.2 - dwg2.dwg

FRANK BENNARDO, P.E.  
PE# 0046549 CA# 9885

FEBRUARY 19, 2024

FL

APPROVED DESIGN  
PRESSURES (ASD):

LATERAL	UPLIFT
200 PSF	100 PSF

FRANK L. BENNARDO  
LICENSE  
No. PE0046549  
STATE OF FLORIDA  
PROFESSIONAL ENGINEER  
02/27/2024

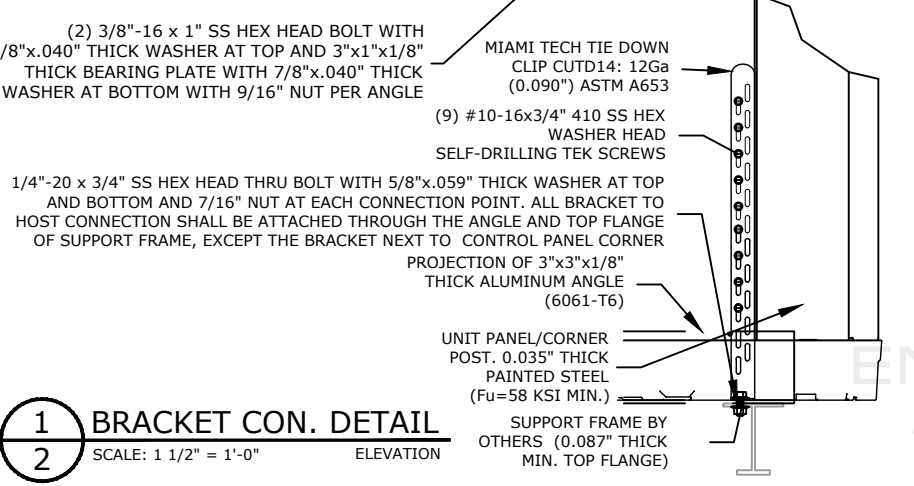
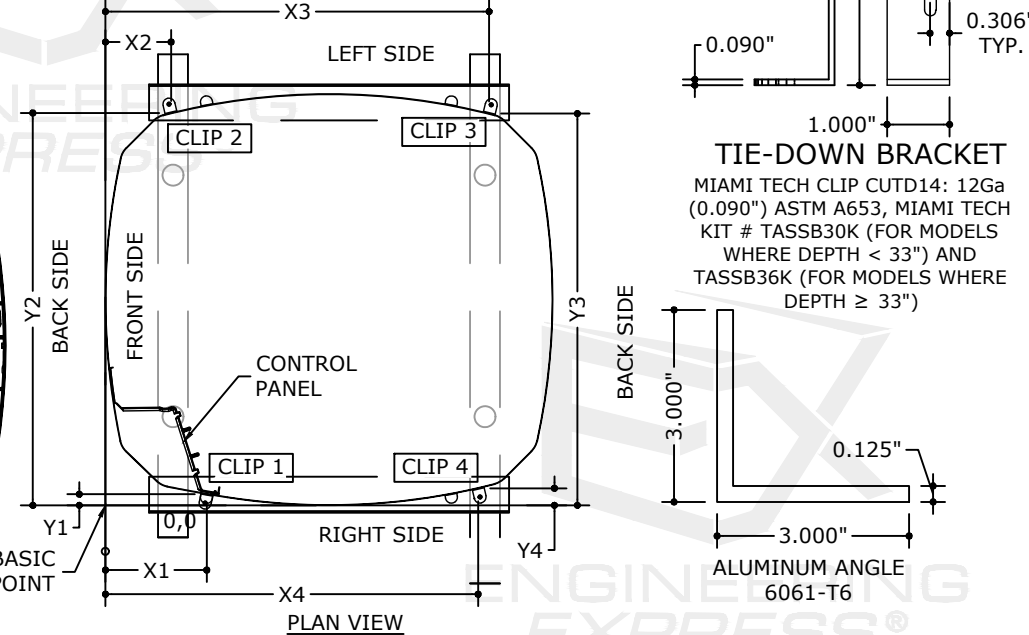
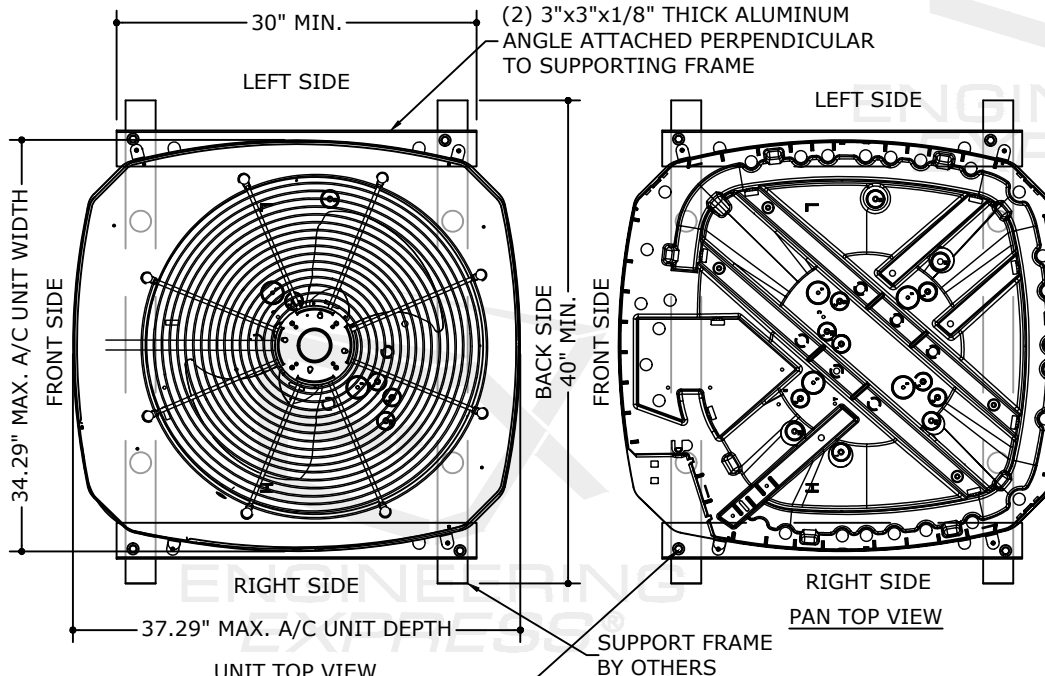
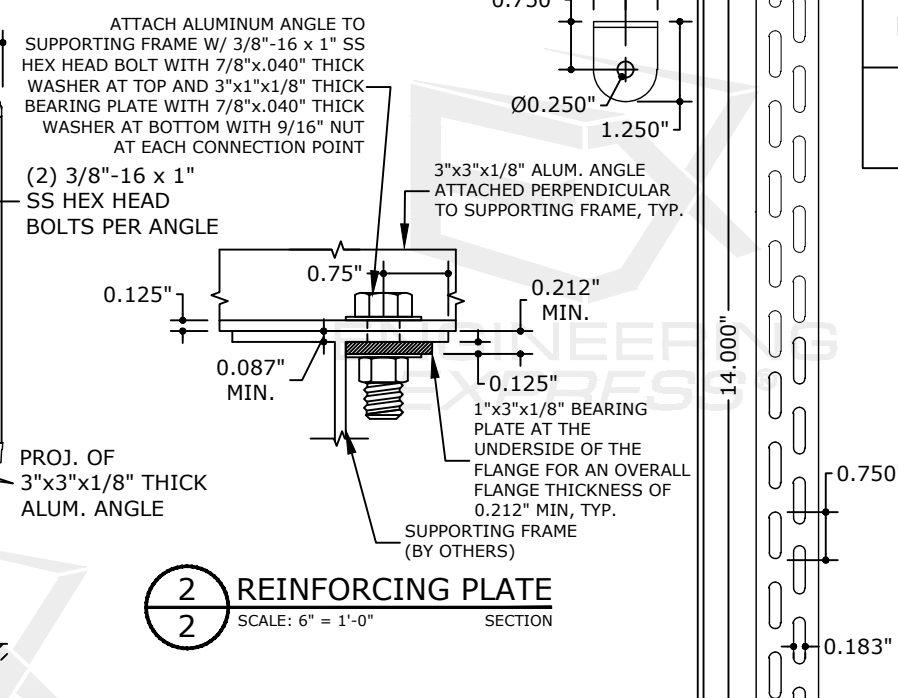
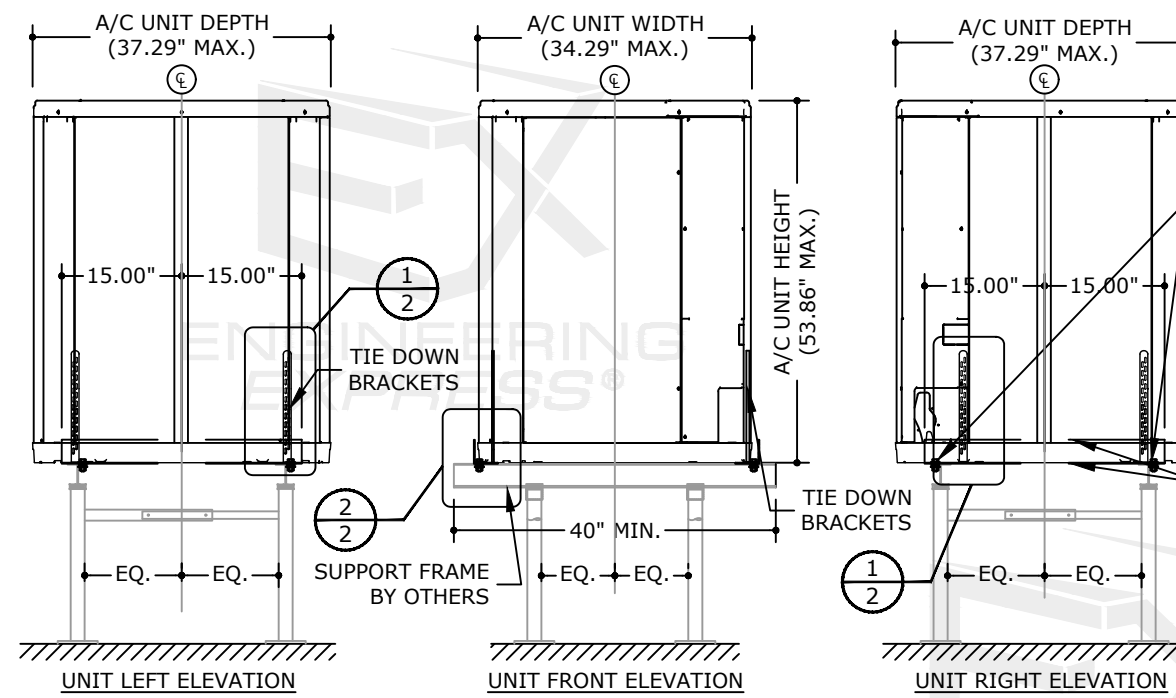

APPLICABLE MODELS:  
2/4A6B, 4A6C, 4A6H, 4A6Z, 4A6V,  
2/4A7B, 2/4A7C, 4A7A, 4A7Z, 4A7V, 2/4TTA, 2/4TTB, 2/4TWB,  
5A6C, 5A6H, 5A6V, 5A7A, 5A7C, 5A7V

AMERICAN STANDARD UNITS													
DESIGNATION	ITEM	UNIT WEIGHT (LB)	UNIT DIMENSIONS (IN)			ANCHOR LOCATION DIMENSIONS (IN)							
			WIDTH	DEPTH	HEIGHT	CLIP 1		CLIP 2		CLIP 3		CLIP 4	
						X1	Y1	X2	Y2	X3	Y3	X4	Y4
TYPICAL UNIT	1	120	25.69	28.42	32.77	6 1/2	5/8	4 3/8	24 3/8	24 3/8	24 3/8	23 5/8	1
	2	120	25.69	28.42	25.60	6 1/2	5/8	4 3/8	24 3/8	24 3/8	24 3/8	23 5/8	1
	3	120	29.69	32.65	40.70	7 3/8	3/4	4 3/4	28 1/4	28	28 1/4	27 1/4	1 1/4
	4	120	29.69	32.65	28.77	7 3/8	3/4	4 3/4	28 1/4	28	28 1/4	27 1/4	1 1/4
	5	245	34.29	37.29	45.77	8 1/2	7/8	5 1/2	32 3/4	32	32 5/8	31	1 3/8
	6	120	34.29	37.29	29.18	8 1/2	7/8	5 1/2	32 3/4	32	32 5/8	31	1 3/8

FL 19588.2

**ENGINEERING EXPRESS**

POSTAL ADDRESS:  
2234 NORTH FEDERAL HWY # 7664  
BOCA RATON, FL 33431  
ENGINEERINGEXPRESS.COM

**TRANE TECHNOLOGIES**

6200 TROUP HWY  
TYLER, TX 75707  
PHONE: (903) 730-4602

AMERICAN STANDARD CONDENSER (ROOF MOUNTED)  
FLORIDA BUILDING CODE EIGHTH EDITION (2023)  
FLORIDA STATEWIDE APPROVAL (FSA)

REMARKS	DRWN	CHKD	DATE
PREV. SUBMITTAL (20-28639)	CCB	FLB	11/19/21
2023 FBC UPDATE	EPR	RWN	10/23/23
ADD MODELS	EPR	EPR	02/19/24

COPYRIGHT ENGINEERING EXPRESS®

23-68286

SCALE: NTS UNLESS NOTED

2 OF 3

**APPENDIX A: DESIGN WIND PRESSURE GUIDE**

Max. Ult. Wind Speed (V <sub>ult</sub> )	Max. MRH (Roof Height)	Exposure Category	Required Design Wind Pressures (ASD)	
			Lateral Pressure	Uplift Pressure
140 mph	At-Grade (0 ft)	C	± 26 psf	0* psf
		D	± 31 psf	0* psf
	100 ft	C	± 63 psf	50 psf
		D	± 71 psf	56 psf
	200 ft	C	± 72 psf	57 psf
		D	± 80 psf	63 psf
175 mph	At-Grade (0 ft)	C	± 40 psf	0* psf
		D	± 49 psf	0* psf
	100 ft	C	± 98 psf	77 psf
		D	± 111 psf	87 psf
	200 ft	C	± 113 psf	89 psf
		D	± 124 psf	98 psf
186 mph	At-Grade (0 ft)	C	± 46 psf	0* psf
		D	± 54 psf	0* psf
	100 ft	C	± 111 psf	87 psf
		D	± 125 psf	99 psf
	200 ft	C	± 127 psf	100 psf
		D	± 140 psf	111 psf

±100 psf

Note: Any table values with the format shown left, if present, indicate design wind pressures and site conditions that are **not approved for use** by this evaluation. Seek additional engineering or contact this firm for design solutions.

**DIRECTIVE:** This design pressure guide is for reference only and shall be approved for use by the Authority Having Jurisdiction (AHJ). If the design pressures listed in this guide are not used, required design pressures shall be calculated separately. For site-specific scenarios classified as Exposure Category B, the required design pressures stated for Exposure Category C in the above guide shall be used or design pressures shall be calculated separately. For heights and parameters beyond the parameters listed in this guide, visit our Online Calculator via the website link (<https://ecalc.io/forces>) or QR Code below, or obtain calculations separately by others.

The required ASD design pressures listed in this guide were calculated per the table's listed corresponding site conditions. The project design professional or permitting contractor shall verify that the site-specific conditions are equal to or less than the approved design parameters listed in the guide. Per the note below table: any values shown as "XX psf", indicate wind pressures and corresponding site conditions that are **not valid for use** with this evaluation (exceeds the max. rated pressures).

\*Note: Per the codes and standards referenced herein, uplift is not required for mechanical equipment at-grade. If uplift at-grade is required by the AHJ, contact this firm for a site-specific evaluation.

**At-Grade (0 ft MRH) Required Design Pressures:**

- o ASCE 7 "Design Wind Loads: Other Structures"
- o Structure Shape = Square, flat terrain
- o Height of structure (unit + stand or curb, if used) = 6 ft max.
- o Width of unit = 1 ft min., Depth of unit = 11 in min.

**Rooftop (>15 ft MRH) Required Design Pressures:**

- o ASCE 7 "Design Wind Loads: Other Structures: Rooftop Structures and Equipment for Buildings"
- o Structure Shape = Square, flat terrain
- o z = up to 7 ft, where z = height of stand or curb + ½ unit height
- o Lateral GC<sub>f</sub> = 1.90; Uplift GC<sub>f</sub> = 1.50

**UNIT REACTIONS FROM WIND GUIDE**

**DIRECTIVE:** This guide is intended for use by a design professional. Design parameters shall abide all specifications and limitations stated in this report. Design professional shall consider all forces, including seismic and snow loads, per the governing building code. Unit reactions obtained from this guide shall be verified by a registered Professional Engineer. Reactions are applicable for unit-to-host connections only. Sample calculations are provided below.

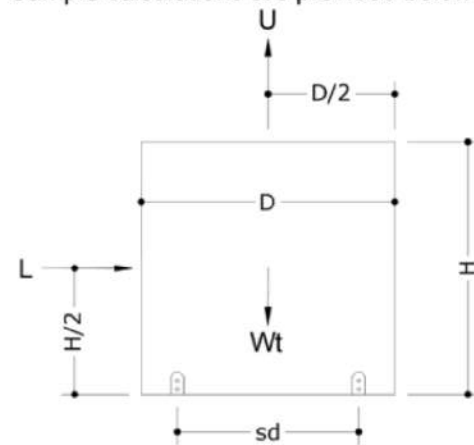

**Design Parameters:**

- Lateral Wind Pressure, P<sub>lat</sub>
- Uplift Wind Pressure, P<sub>up</sub>
- Unit Height, H
- Unit Depth, D
- Unit Width, W
- Unit Weight, Wt
- Support Spacing across Depth, sd
- Support Spacing across Width, sw

**Unit Reaction Equations:**

**Long Side (Width x Height):**

- Sliding Force, L = P<sub>lat</sub> x W x H
- Uplift Force, U = P<sub>up</sub> x W x D
- Total Tension per Long Side = ( L x H/2 + U x sd/2 - Wt x 0.6 x sd/2 ) / sd

**Short Side (Depth x Height):**

- Sliding Force, L = P<sub>lat</sub> x D x H
- Uplift Force, U = P<sub>up</sub> x W x D
- Total Tension per Short Side = ( L x H/2 + U x sw/2 - Wt x 0.6 x sw/2 ) / sw

**Example:** A (48" W x 36" D x 42" H), 250 lb net weight unit at wind pressures of 120 psf lateral and 95 psf uplift, on a 24" wide roof stand, shall have the following unit reactions:

**Long Side (Width x Height):**

- Sliding Force, L = P<sub>lat</sub> x W x H  
= (120 psf) x (48 in) x (42 in) x (1 in<sup>2</sup> / 144 ft<sup>2</sup>) = **1680 lb**
- Uplift Force, U = P<sub>up</sub> x W x D  
= (95 psf) x (48 in) x (36 in) x (1 in<sup>2</sup> / 144 ft<sup>2</sup>) = **1140 lb**
- Total Tension per Long Side =  
= ( L x H/2 + U x sd/2 - Wt x 0.6 x sd/2 ) / sd  
= ( (1680 lb x 42/2 in) + (1140 lb x 24/2 in) - (250 lb x 0.6 x 24/2 in) ) / 24 in = **1965 lb**

**Short Side (Depth x Height):**

- Sliding Force, L = P<sub>lat</sub> x D x H  
= (120 psf) x (36 in) x (42 in) x (1 in<sup>2</sup> / 144 ft<sup>2</sup>) = **1260 lb**
- Uplift Force, U = P<sub>up</sub> x W x D  
= (95 psf) x (48 in) x (36 in) x (1 in<sup>2</sup> / 144 ft<sup>2</sup>) = **1140 lb**
- Total Tension per Short Side =  
= ( L x H/2 + U x sw/2 - Wt x 0.6 x sw/2 ) / sw  
= ( (1260 lb x 42/2 in) + (1140 lb x 48/2 in) - (250 lb x 0.6 x 48/2 in) ) / 48 in = **1046 lb**

**IN ALL CONDITIONS IT IS THE RESPONSIBILITY OF THE PERMIT HOLDER TO ENSURE THE HOST STRUCTURE IS CAPABLE OF WITHSTANDING THE RATED GRAVITY, LATERAL, AND UPLIFT FORCES BY SITE-SPECIFIC DESIGN. NO WARRANTY OF ANY KIND, EXPRESSED OR IMPLIED, IS OFFERED BY ENGINEERING EXPRESS AS TO THE INTEGRITY OF THE HOST STRUCTURE TO CARRY DESIGN FORCE LOADS INCURRED BY THIS UNIT.**

FRANK BENNARDO, P.E.  
PE# 0046549 CA# 9885

FEBRUARY 19, 2024

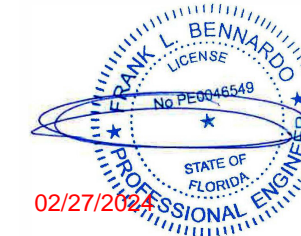

FL

FL 19588.2

**ENGINEERING EXPRESS®**  
POSTAL ADDRESS:  
2234 NORTH FEDERAL HWY # 7664  
BOCA RATON, FL 33431  
ENGINEERINGEXPRESS.COM

**TRANE TECHNOLOGIES**

6200 TROUP HWY  
TYLER, TX 75707  
PHONE: (903) 730-4602  
AMERICAN STANDARD CONDENSER (ROOF MOUNTED)  
FLORIDA BUILDING CODE EIGHTH EDITION (2023)  
FLORIDA STATEWIDE APPROVAL (FSA)

REMARKS	DRWN	CHKD	DATE
PREV. SUBMITTAL (20-28639)	CCB	FLB	11/19/21
2023 FBC UPDATE	EPR	RWN	10/23/23
ADD MODELS	EPR	EPR	02/19/24

23-68286

SCALE: NTS UNLESS NOTED

3 OF 3

c:\users\eric\engineering express\production - documents\projects\23-123-68286\2023 fbc update american standard condenser-roof mounted-steel tie-down clip system\work\2023 fbc\drawings & cad\23-68286g - cad\23-68286g - dwg2.dwg