

REVISIONS			
REV	DESCRIPTION	DATE	APPROVED

NOTES:

1. THE PRODUCT SHOWN HEREIN IS DESIGNED AND MANUFACTURED TO COMPLY WITH REQUIREMENTS OF THE FLORIDA BUILDING CODE.
2. WOOD FRAMING AND MASONRY OPENING TO BE DESIGNED AND ANCHORED TO PROPERLY TRANSFER ALL LOADS TO STRUCTURE. FRAMING AND MASONRY OPENING IS THE RESPONSIBILITY OF THE ARCHITECT OR ENGINEER OF RECORD.
3. 1X BUCK OVER MASONRY/CONCRETE IS OPTIONAL.
4. WHERE SHIM OR BUCK THICKNESS IS LESS THAN 1-1/2" UNITS MUST BE ANCHORED THROUGH THE FRAME IN ACCORDANCE WITH MANUFACTURER'S PUBLISHED INSTALLATION INSTRUCTIONS. ANCHORS SHALL BE SECURELY FASTENED DIRECTLY INTO MASONRY, CONCRETE OR OTHER STRUCTURAL SUBSTRATE MATERIAL.
5. WHERE WOOD BUCK THICKNESS IS 1-1/2" OR GREATER, BUCK SHALL BE SECURELY FASTENED TO MASONRY, CONCRETE OR OTHER STRUCTURAL SUBSTRATE. UNITS MAY BE ANCHORED THROUGH FRAME TO SECURED WOOD BUCK IN ACCORDANCE WITH MANUFACTURER'S PUBLISHED INSTALLATION INSTRUCTIONS.
6. WHERE 1X BUCK IS NOT USED DISSIMILAR MATERIALS MUST BE SEPARATED WITH APPROVED COATING OR MEMBRANE. SELECTION OF COATING OR MEMBRANE IS THE RESPONSIBILITY OF THE ARCHITECT OR ENGINEER OF RECORD.
7. BUCKS SHALL EXTEND BEYOND UNIT FRAME INTERIOR FACE SO THAT FULL FRAME SUPPORT IS PROVIDED.
8. SHIM AS REQUIRED AT EACH ANCHOR LOCATION WITH LOAD BEARING SHIM. SHIM WHERE SPACE OF 1/16" OR GREATER OCCURS. MAXIMUM ALLOWABLE SHIM STACK TO BE 1/4".
9. SHIMS SHALL BE LOCATED, APPLIED AND MADE FROM MATERIALS AND THICKNESS CAPABLE OF SUSTAINING APPLICABLE LOADS.
10. WIND LOAD DURATION FACTOR Cd=1.6 WAS USED FOR WOOD ANCHOR CALCULATIONS.
11. FRAME MATERIAL: FOAM PVC CO-EX.
12. UNITS MUST BE GLAZED PER ASTM E1300-04/09, SEE SHEET 2 FOR GLASS DETAILS.
13. APPROVED IMPACT PROTECTIVE SYSTEM IS NOT REQUIRED FOR THIS PRODUCT IN WIND BORNE DEBRIS REGIONS.
14. FOR ANCHORING THROUGH FRAME INTO WOOD FRAMING OR 2X BUCK USE #10 WOOD SCREWS WITH SUFFICIENT LENGTH TO ACHIEVE A 1 1/4" MINIMUM EMBEDMENT INTO SUBSTRATE. LOCATE ANCHORS AS SHOWN IN ELEVATIONS AND INSTALLATION DETAILS.

15. FOR ANCHORING THROUGH FRAME INTO MASONRY/CONCRETE USE 1/4" TAPCONS WITH SUFFICIENT LENGTH TO ACHIEVE A 1 1/4" MINIMUM EMBEDMENT INTO SUBSTRATE WITH 2" MINIMUM EDGE DISTANCE. LOCATE ANCHORS AS SHOWN IN ELEVATIONS AND INSTALLATION DETAILS.
16. FOR ANCHORING THROUGH FRAME INTO METAL STRUCTURE USE #10 SMS OR SELF DRILLING SCREWS WITH SUFFICIENT LENGTH TO ACHIEVE 3 THREADS MINIMUM BEYOND STRUCTURE INTERIOR WALL. LOCATE ANCHORS AS SHOWN IN ELEVATIONS AND INSTALLATION DETAILS.
17. ALL FASTENERS TO BE CORROSION RESISTANT.
18. INSTALLATION ANCHORS SHALL BE INSTALLED IN ACCORDANCE WITH ANCHOR MANUFACTURER'S INSTALLATION INSTRUCTIONS AND ANCHORS SHALL NOT BE USED IN SUBSTRATES WITH STRENGTHS LESS THAN THE MINIMUM STRENGTH SPECIFIED BELOW:
 - A. WOOD: MINIMUM SPECIFIC GRAVITY OF G=0.42
 - B. CONCRETE: MINIMUM COMPRESSIVE STRENGTH OF 2,000 PSI.
 - C. MASONRY: HOLLOW/FILLED BLOCK PER ASTM C90 WITH Fm=2,000PSI MINIMUM.
 - D. METAL STRUCTURE: STEEL 18GA (.048") FY=33KSI/FU=52KSI OR ALUMINUM 6063-T5 FU=30KSI .054" THICK MINIMUM

SIGNED: 05/06/2019

TABLE OF CONTENTS	
SHEET NO.	DESCRIPTION
1	NOTES
2	ELEVATION AND GLAZING DETAILS
3 - 5	INSTALLATION DETAILS
6 - 7	COMPONENTS

NAN YA PLASTICS CORPORATION USA 8989 NORTH LOOP EAST HOUSTON, TX 77029		
SERIES "PRBJ" FIBERGLASS OUTSWING FOLDING DOOR - IMPACT NOTES		
DRAWN: A.R.	DWG NO. 08-03406	REV -
SCALE NTS	DATE 04/03/19	SHEET 1 OF 7
L. ROBERTO LOMAS P.E. 1432 WOODFORD RD LEWISVILLE, NC 27023 434-688-0609 rllomas@lrlomaspe.com		

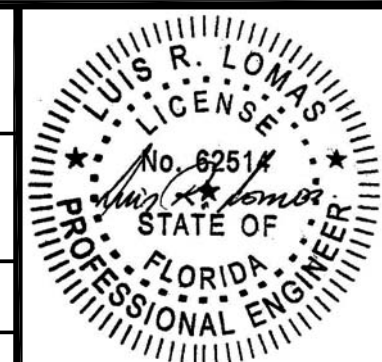

Luis R. Lomas P.E.
FL No.: 62514

REVISIONS			
REV	DESCRIPTION	DATE	APPROVED

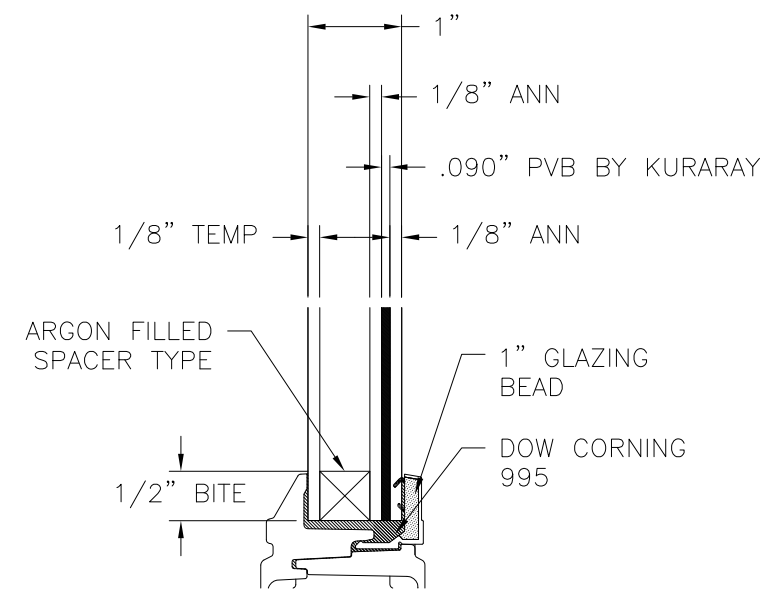
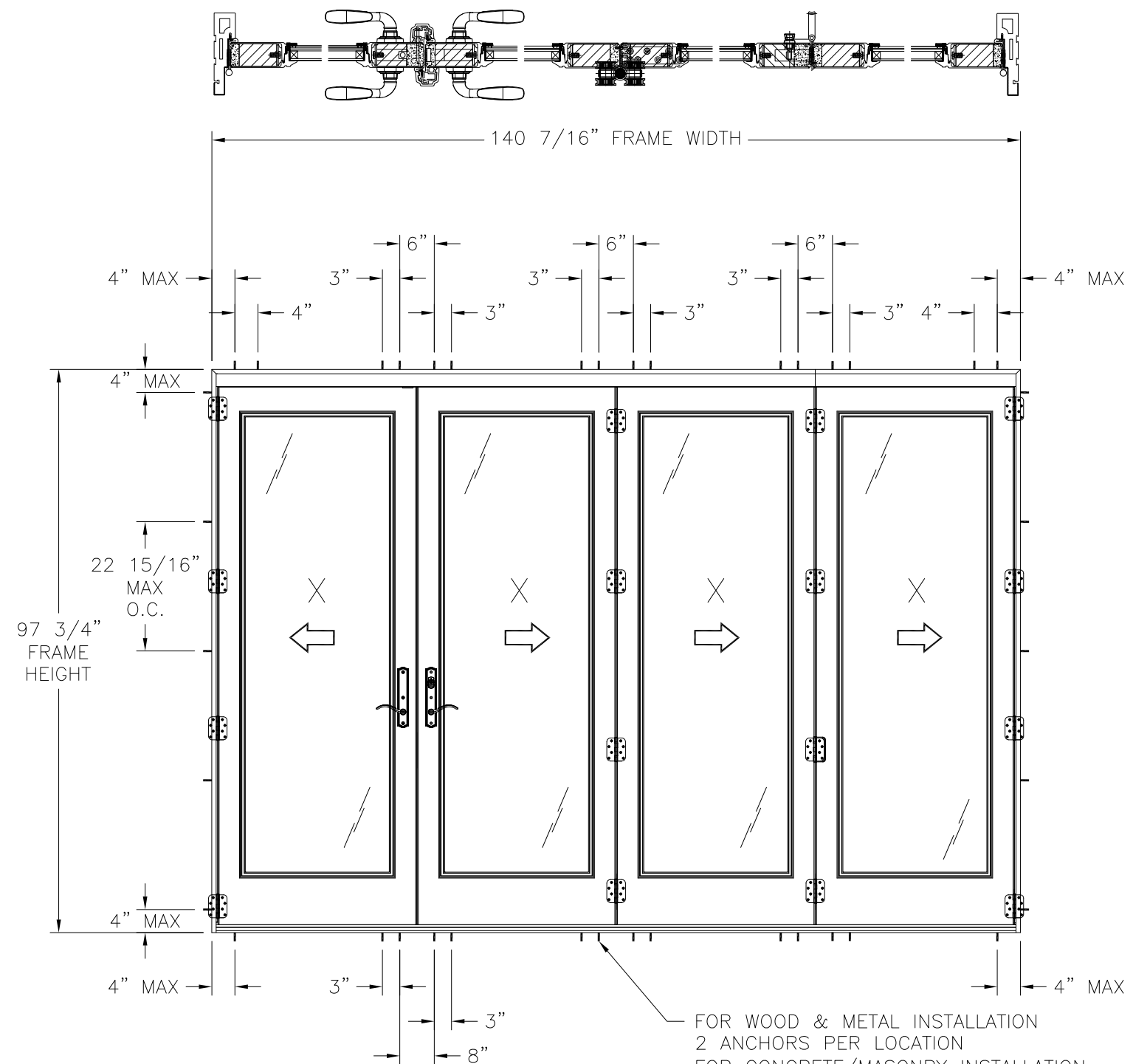

GLAZING DETAIL

HARDWARE SCHEDULE	
A.	(1) SLAB MULTI-POINT LOCK WITH KEEPER (STAINLESS STEEL)
B.	TOP AND BOTTOM DRIVE BAR SYSTEM WITH KEEPERS (STAINLESS STEEL, STEEL)
C.	(1) FLUSH BOLT SYSTEM WITH KEEPERS (DIE CAST, STEEL)
D.	(1) STEEL 4 X 3 1/4 DOOR HINGE (A & B)
E.	(1) HANDLE SET AT ACTIVE AND PASSIVE PANEL WITH ASTRAGAL
F.	WOOD REINFORCEMENT 2 5/8" (A) (WHITE PINE)
G.	WOOD REINFORCEMENT 2 1/8" (B) (WHITE PINE)
H.	WOOD REINFORCEMENT 1 3/8" (C) (WHITE PINE)
I.	STEEL REINFORCEMENT 1/8" (SPHC)
J.	SCREW 11/32" X 19/32" (NYLON 66)
K.	T-ASTRAGAL REINFORCEMENT (ALUMINUM)

- NOTES:**
 1. PANEL SIZE.: 34 1/2" X 93 5/16"
 2. D.L.O.: 25" X 79"

SIGNED: 05/06/2019

SERIES "PRBJ" FIBERGLASS OUTSWING FOLDING DOOR

DESIGN PRESSURE RATING	IMPACT RATING
±50.0PSF	LARGE AND SMALL MISSILE IMPACT

MISSILE LEVEL D, WIND ZONE 4
 (4) PANELS SHOWN, UNLIMITED NUMBER OF PANELS IN UNLIMITED CONFIGURATIONS IS APPLICABLE AS LONG AS INDIVIDUAL PANEL AREA DOES NOT EXCEED 22.35 FT²

NAN YA PLASTICS CORPORATION USA
 8989 NORTH LOOP EAST
 HOUSTON, TX 77029

SERIES "PRBJ" FIBERGLASS
 OUTSWING FOLDING DOOR - IMPACT
 ELEVATION AND GLAZING DETAIL

DRAWN: A.R.	DWG NO. 08-03406	REV -
SCALE NTS	DATE 04/03/19	SHEET 2 OF 7

L. ROBERTO LOMAS P.E.
 1432 WOODFORD RD LEWISVILLE, NC 27023
 434-688-0609 rllomas@rlomaspe.com

Luis R. Lomas P.E.
 FL No.: 62514

REVISIONS			
REV	DESCRIPTION	DATE	APPROVED

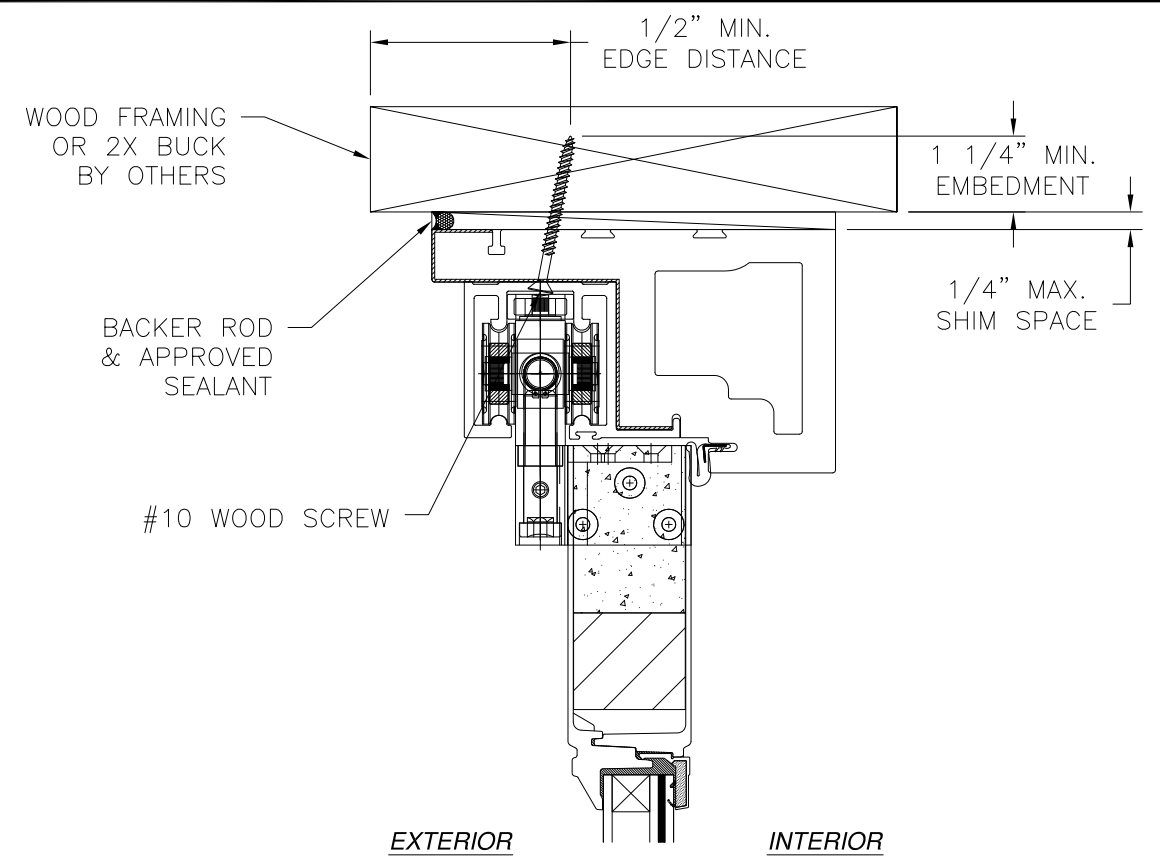

EXTERIOR INTERIOR

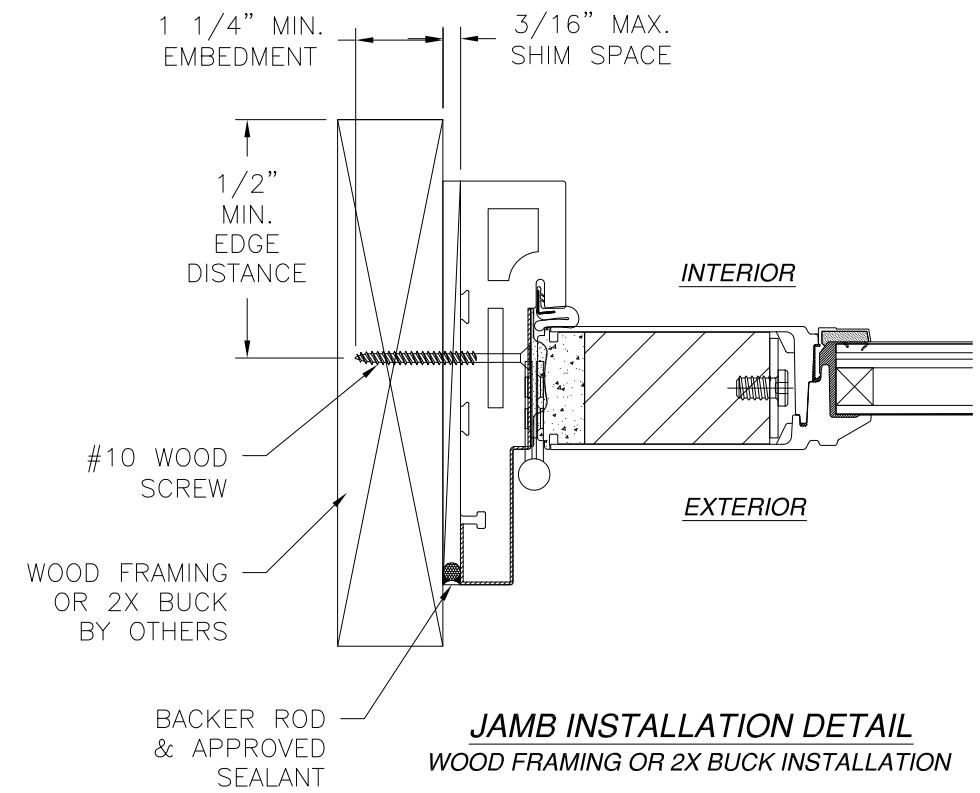

JAMB INSTALLATION DETAIL
WOOD FRAMING OR 2X BUCK INSTALLATION

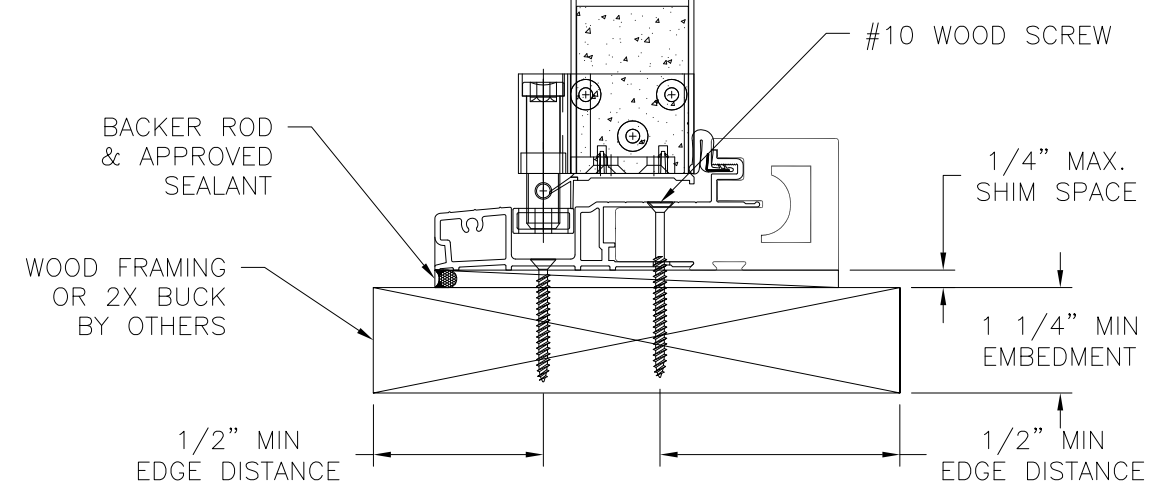

VERTICAL CROSS SECTION
WOOD FRAMING OR 2X BUCK INSTALLATION

- NOTES:**
1. INTERIOR AND EXTERIOR FINISHES, BY OTHERS, NOT SHOWN FOR CLARITY.
 2. PERIMETER AND JOINT SEALANT BY OTHERS TO BE DESIGNED IN ACCORDANCE WITH ASTM E2112

SIGNED: 05/06/2019

NAN YA PLASTICS CORPORATION USA
8989 NORTH LOOP EAST
HOUSTON, TX 77029

SERIES "PRBJ" FIBERGLASS
OUTSWING FOLDING DOOR - IMPACT
INSTALLATION DETAILS

DRAWN: A.R.	DWG NO. 08-03406	REV -
SCALE NTS	DATE 04/03/19	SHEET 3 OF 7

L. ROBERTO LOMAS P.E.
1432 WOODFORD RD LEWISVILLE, NC 27023
434-688-0609 rllomas@rlomaspe.com

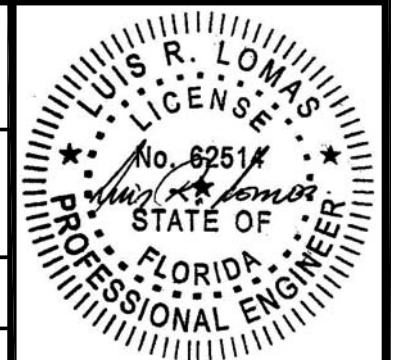

Luis R. Lomas P.E.
FL No.: 62514

REVISIONS			
REV	DESCRIPTION	DATE	APPROVED

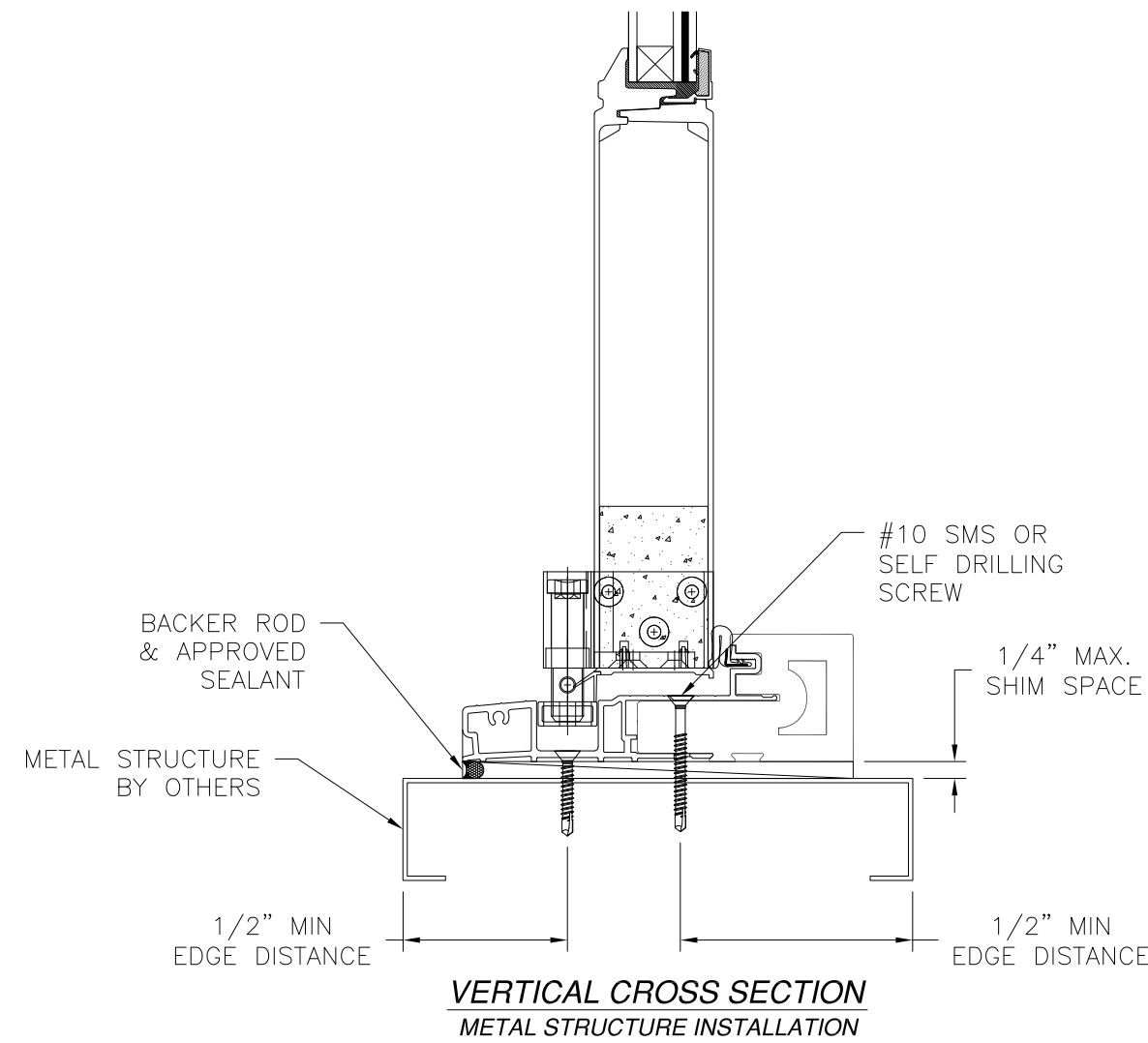
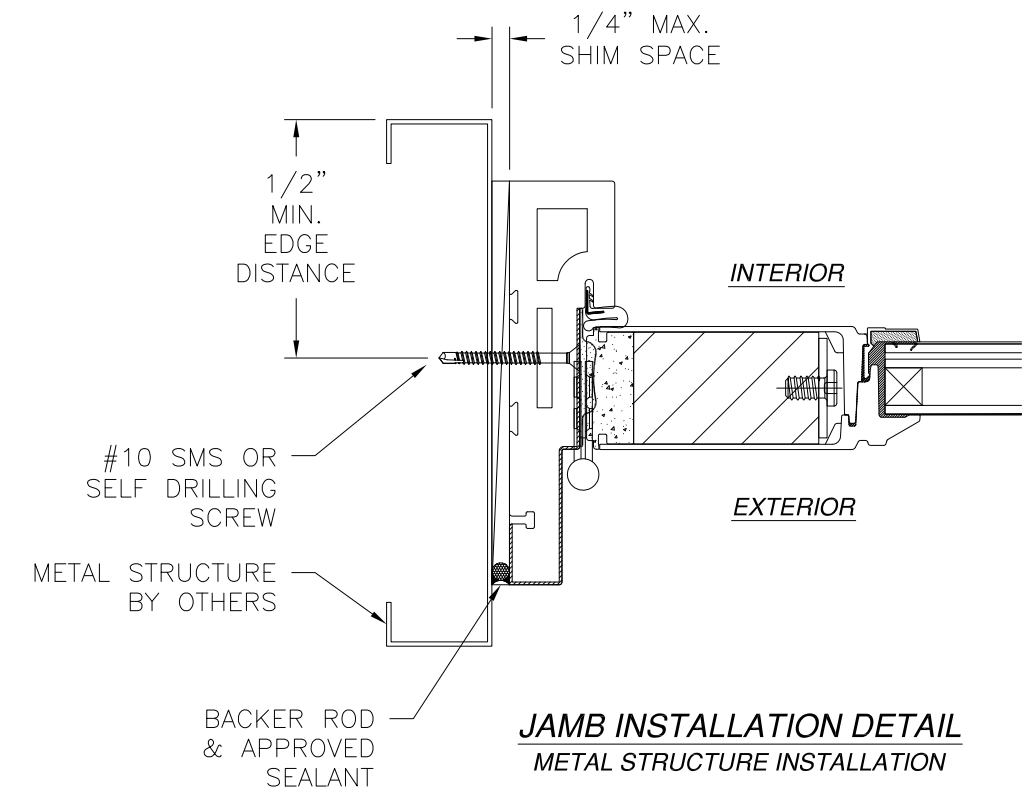
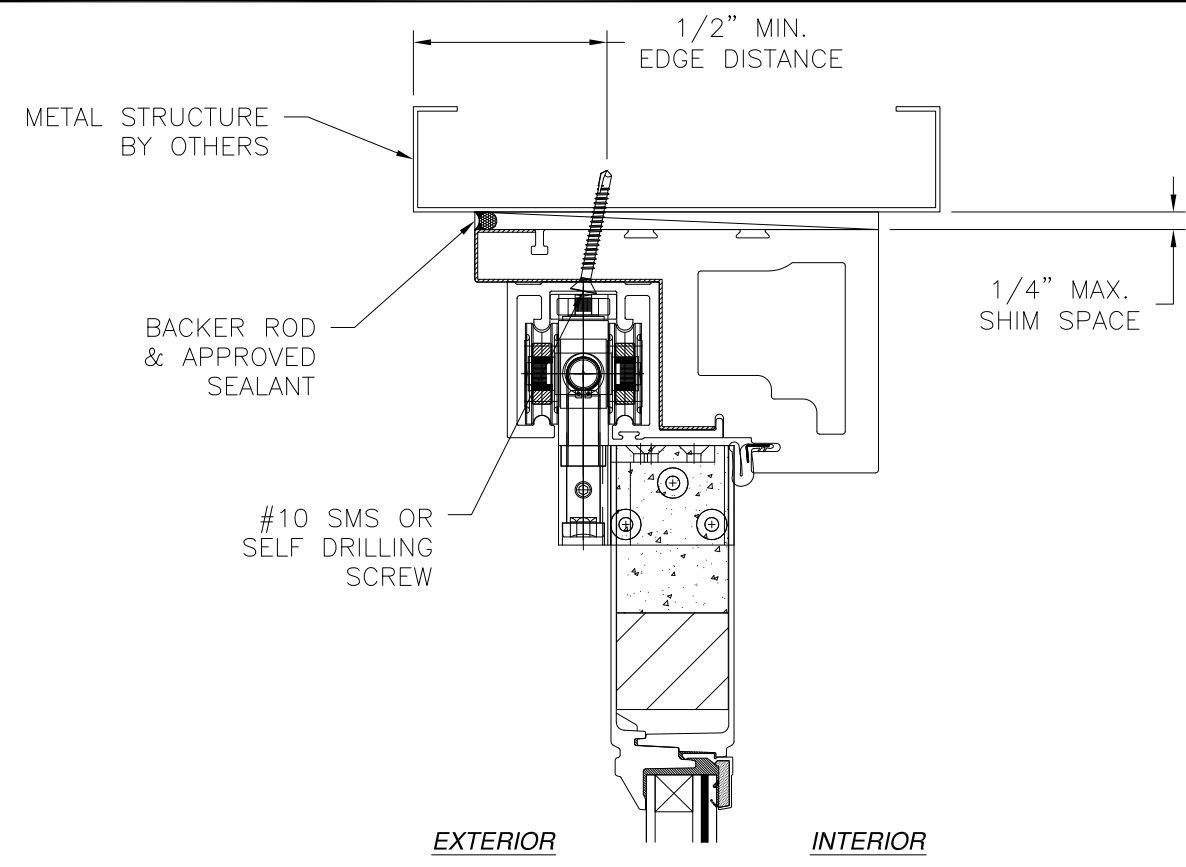

- NOTES:
1. INTERIOR AND EXTERIOR FINISHES, BY OTHERS, NOT SHOWN FOR CLARITY.
 2. PERIMETER AND JOINT SEALANT BY OTHERS TO BE DESIGNED IN ACCORDANCE WITH ASTM E2112

SIGNED: 05/06/2019

NAN YA PLASTICS CORPORATION USA
8989 NORTH LOOP EAST
HOUSTON, TX 77029

SERIES "PRBJ" FIBERGLASS
OUTSWING FOLDING DOOR - IMPACT
INSTALLATION DETAILS

DRAWN: A.R.	DWG NO. 08-03406	REV -
SCALE NTS	DATE 04/03/19	SHEET 4 OF 7

L. ROBERTO LOMAS P.E.
1432 WOODFORD RD LEWISVILLE, NC 27023
434-688-0609 rllomas@rlomaspe.com

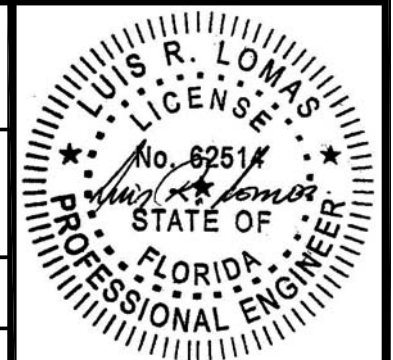

Luis R. Lomas P.E.
FL No.: 62514

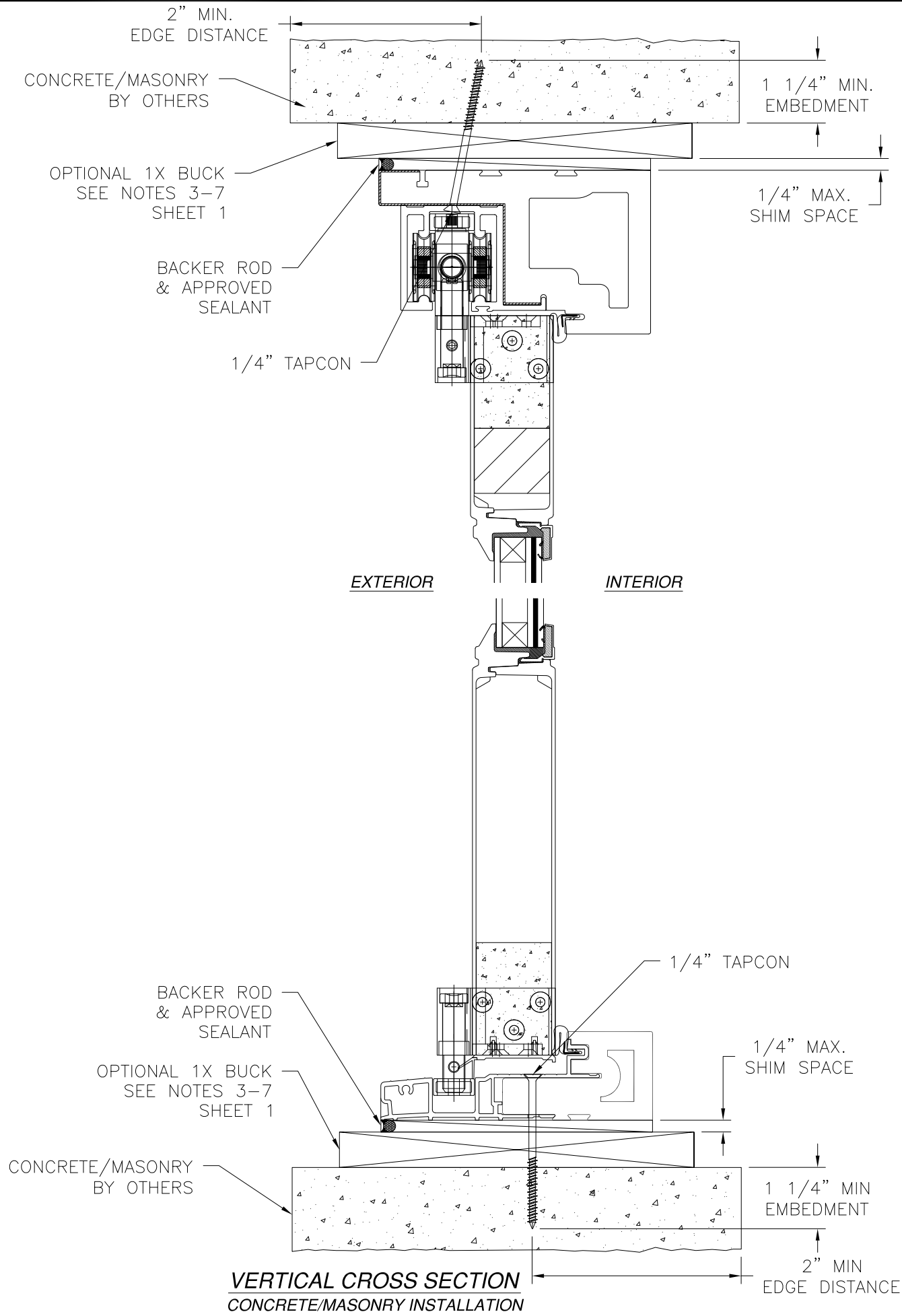

**VERTICAL CROSS SECTION
CONCRETE/MASONRY INSTALLATION**

REVISIONS			
REV	DESCRIPTION	DATE	APPROVED

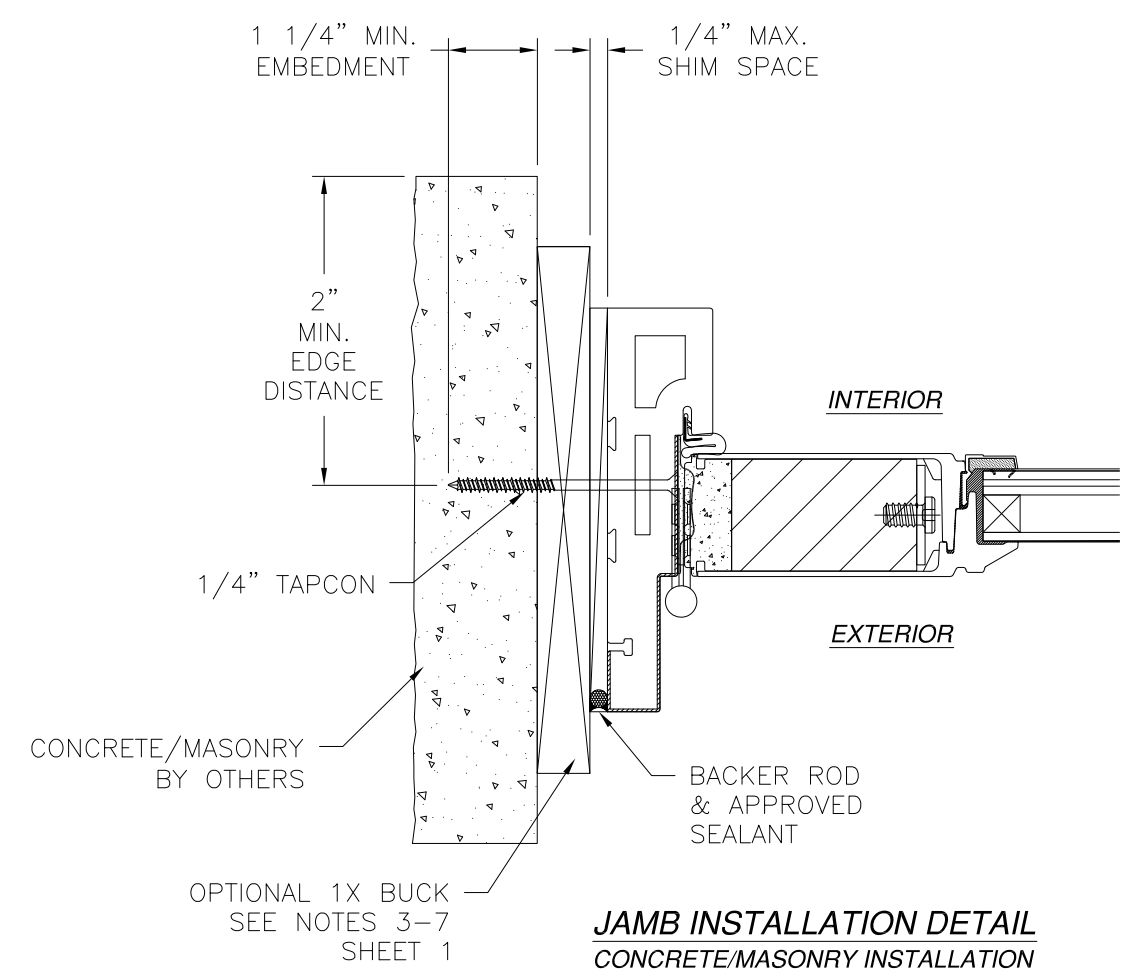

**JAMB INSTALLATION DETAIL
CONCRETE/MASONRY INSTALLATION**

- NOTES:**
1. INTERIOR AND EXTERIOR FINISHES, BY OTHERS, NOT SHOWN FOR CLARITY.
 2. PERIMETER AND JOINT SEALANT BY OTHERS TO BE DESIGNED IN ACCORDANCE WITH ASTM E2112

SIGNED: 05/06/2019

NAN YA PLASTICS CORPORATION USA
 8989 NORTH LOOP EAST
 HOUSTON, TX 77029

SERIES "PRBJ" FIBERGLASS
 OUTSWING FOLDING DOOR - IMPACT
 INSTALLATION DETAILS

DRAWN: A.R.	DWG NO. 08-03406	REV -
SCALE NTS	DATE 04/03/19	SHEET 5 OF 7

L. ROBERTO LOMAS P.E.
 1432 WOODFORD RD LEWISVILLE, NC 27023
 434-688-0609 rllomas@rlomaspe.com

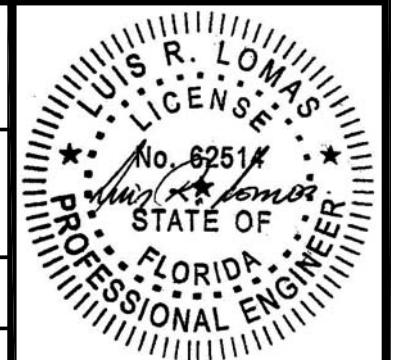

Luis R. Lomas P.E.
 FL No.: 62514

REVISIONS			
REV	DESCRIPTION	DATE	APPROVED

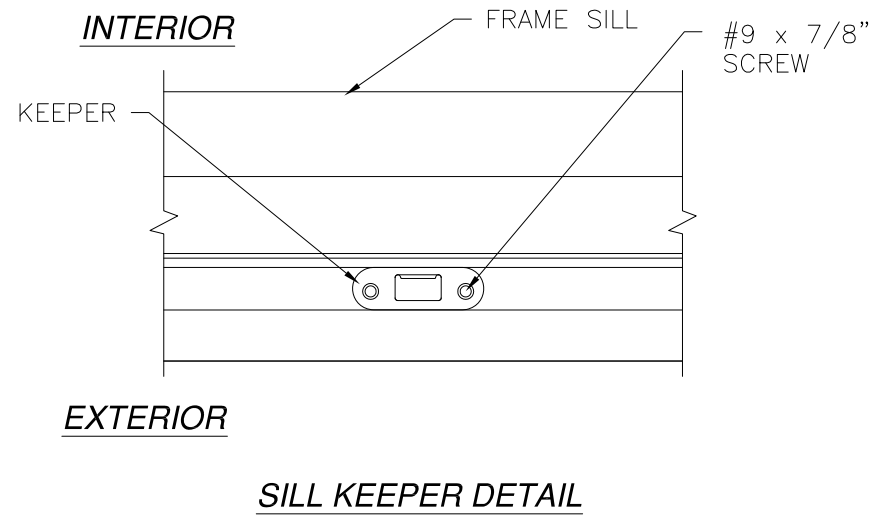
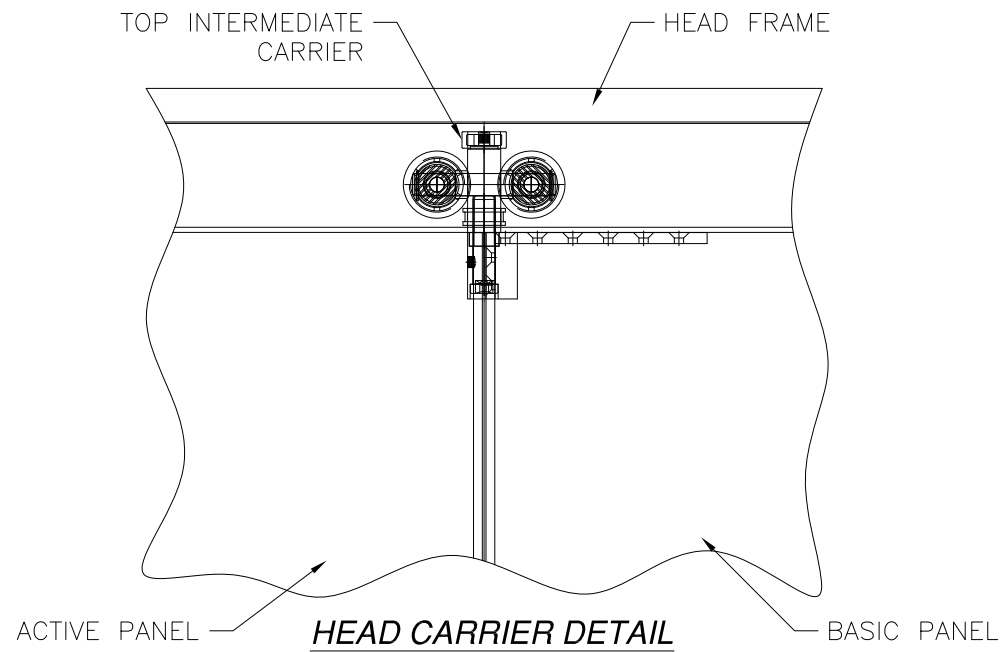
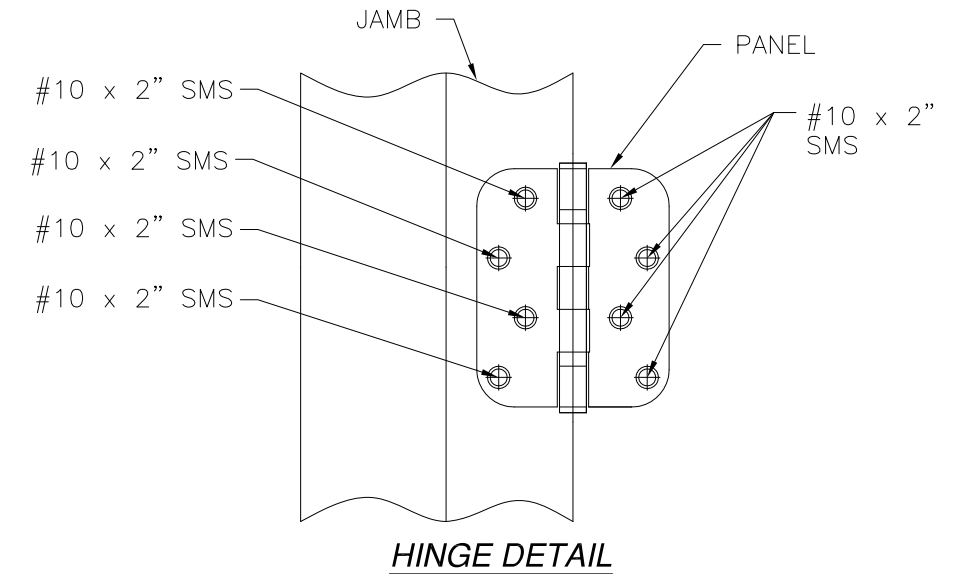
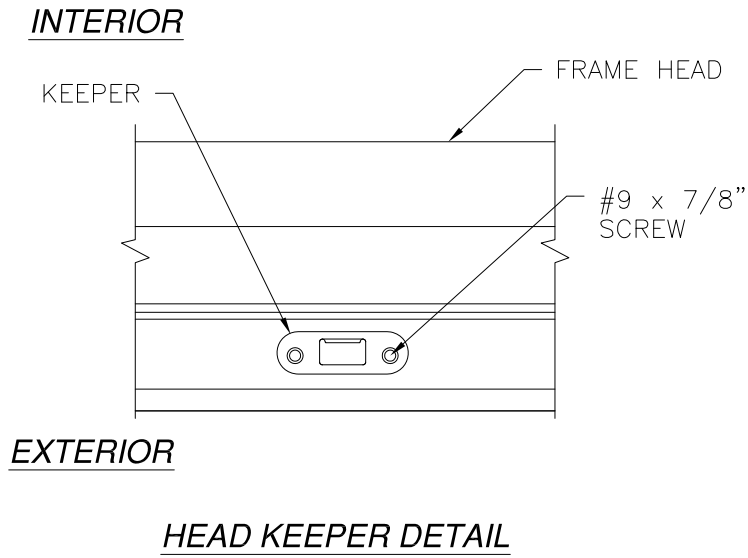
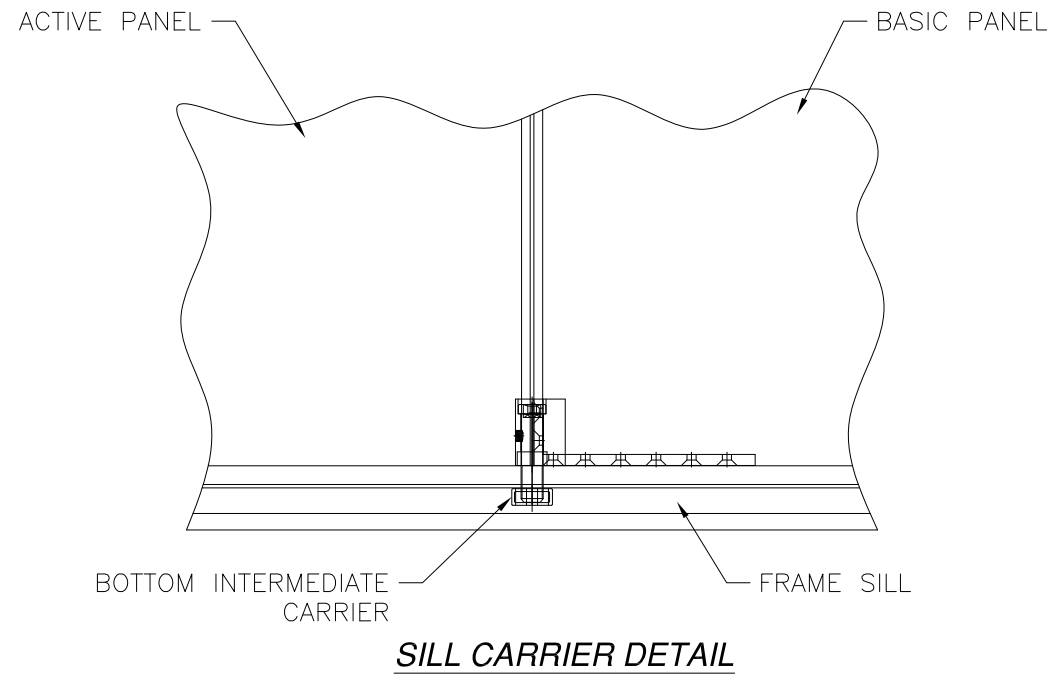

NAN YA PLASTICS CORPORATION USA
 8989 NORTH LOOP EAST
 HOUSTON, TX 77029

SERIES "PRBJ" FIBERGLASS
 OUTSWING FOLDING DOOR - IMPACT
 COMPONENTS DETAILS

DRAWN: A.R.	DWG NO. 08-03406	REV -
SCALE NTS	DATE 04/03/19	SHEET 6 OF 7

L. ROBERTO LOMAS P.E.
 1432 WOODFORD RD LEWISVILLE, NC 27023
 434-688-0609 rllomas@rlomaspe.com

SIGNED: 05/06/2019

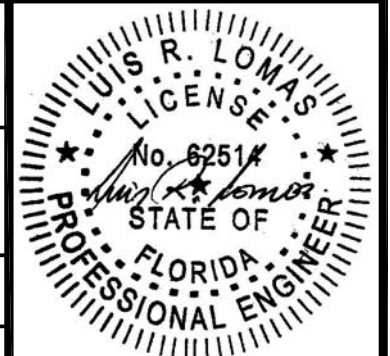

Luis R. Lomas P.E.
 FL No.: 62514

REVISIONS			
REV	DESCRIPTION	DATE	APPROVED

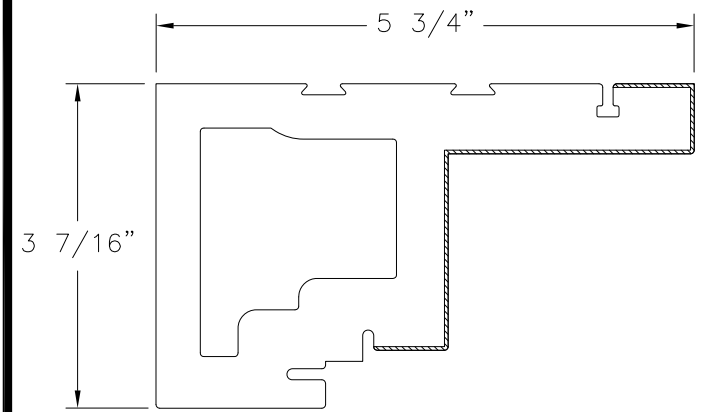

HEAD FRAME
FOAM PVC CO-EX

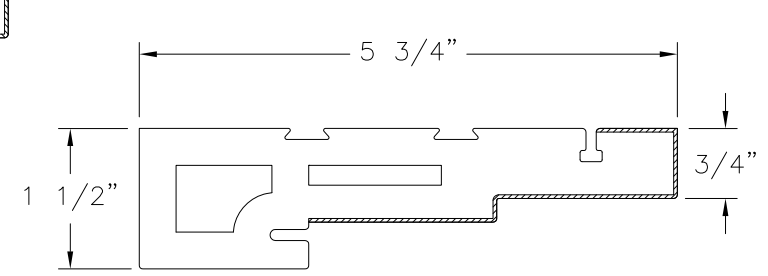

JAMB FRAME
FOAM PVC CO-EX

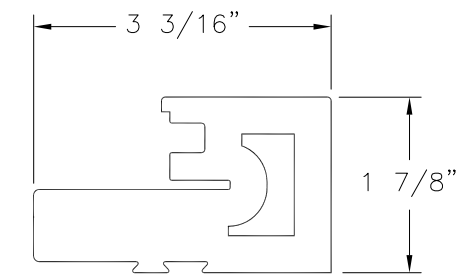

OUTSWING SILL-A
FOAM PVC CO-EX

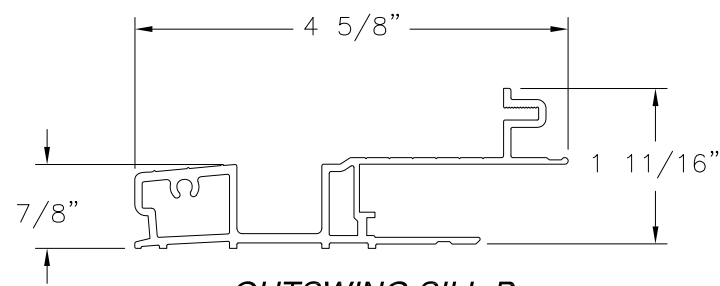

OUTSWING SILL-B
ALUMINUM 6063-T5

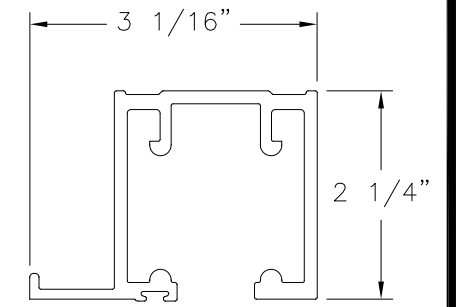

HEAD TRACK
ALUMINUM 6063-T5

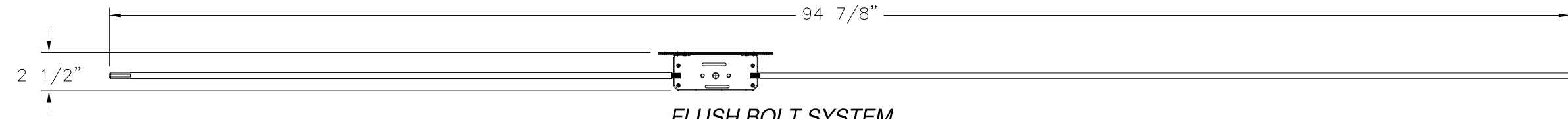

FLUSH BOLT SYSTEM
STEEL BY JAM YUAN ENTERPRISES CO., LTD.

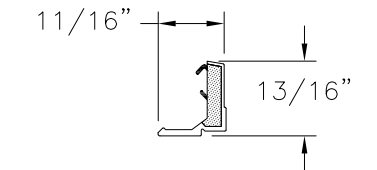

GLAZING BEAD
PVC

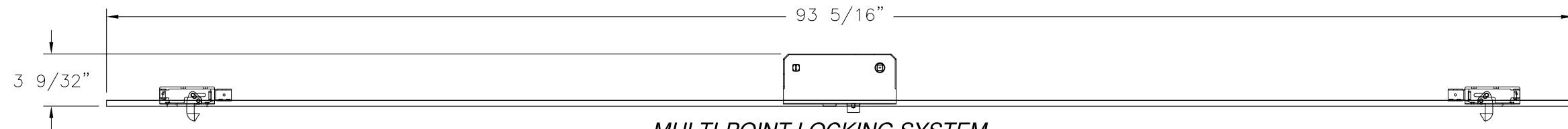

MULTI-POINT LOCKING SYSTEM
STAINLESS STEEL BY JAM YUAN ENTERPRISES CO., LTD.

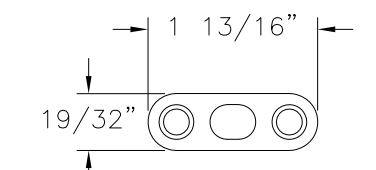

DRIVE BAR PLATE
STAINLESS STEEL (SSP16)
BY JAM YUAN ENTERPRISES CO., LTD

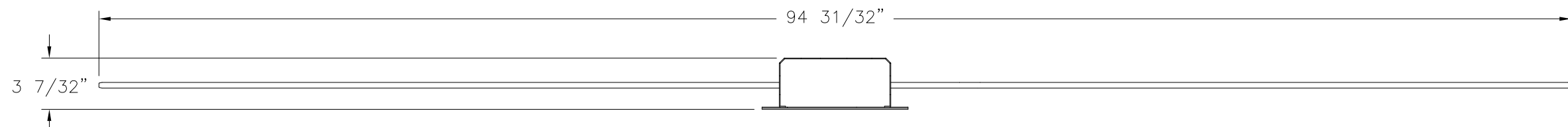

TOP/BOTTOM BAR SYSTEM
STAINLESS STEEL BY JAM YUAN ENTERPRISES CO., LTD.

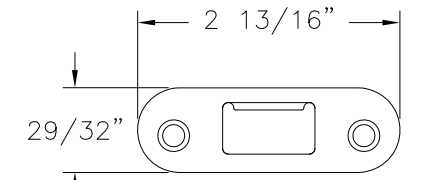

TOP/BOTTOM BAR KEEPER
STAINLESS STEEL (SSF2H)
BY JIUH-CHUAN LOCKS CO., LTD

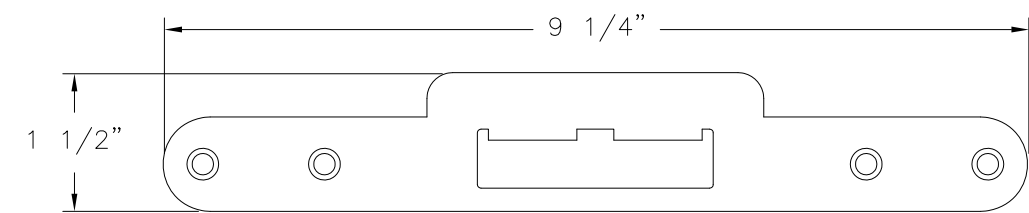

SLAB MULTI-POINT LOCK KEEPER
STAINLESS STEE (SS92F) BY JAM YUAN ENTERPRISES CO., LTD

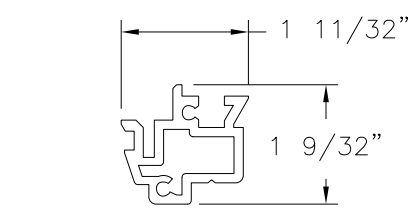

REINFORCEMENT (A)
ALUMINUM

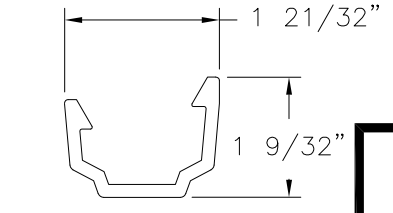

T-ASTRAGAL (A)
RIGID PVC

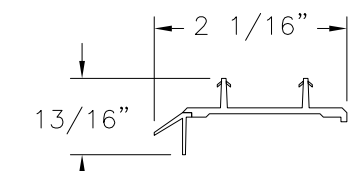

DOOR BOTTOM
FOAM & RIGID PVC

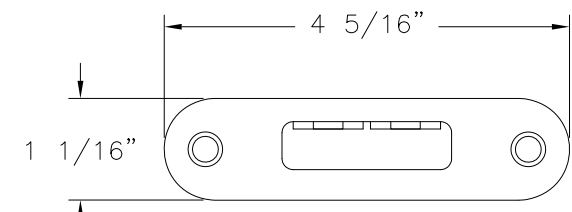

HOOK KEEPER
STAINLESS STEEL (SS92G) BY JIUH-CHUAN LOCKS CO., LTD

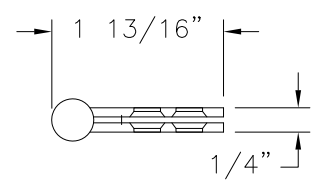

DOOR HINGE A
STEEL

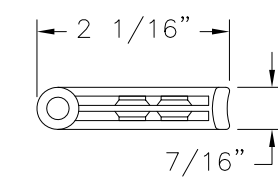

DOOR HINGE B
STEEL

SIGNED: 05/06/2019

NAN YA PLASTICS CORPORATION USA
8989 NORTH LOOP EAST
HOUSTON, TX 77029

SERIES "PRBJ" FIBERGLASS
OUTSWING FOLDING DOOR - IMPACT
COMPONENTS

DRAWN: A.R.	DWG NO. 08-03406	REV -
SCALE NTS	DATE 04/03/19	SHEET 7 OF 7

L. ROBERTO LOMAS P.E.
1432 WOODFORD RD LEWISVILLE, NC 27023
434-688-0609 rllomas@rlomaspe.com

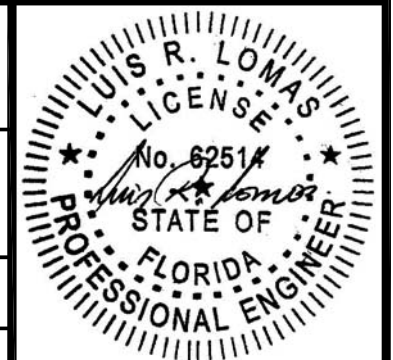

Luis R. Lomas P.E.
FL No.: 62514