

# REGENCY PLUS, INC.

## SERIES TECH 5505 VINYL HORIZONTAL SLIDING (XOX) WINDOW INSTALLATION ANCHORAGE DETAILS

### NOTES:

1. THE PRODUCT SHOWN HEREIN IS DESIGNED AND MANUFACTURED TO COMPLY WITH REQUIREMENTS OF THE CURRENT FLORIDA BUILDING CODE INCLUDING THE HIGH VELOCITY HURRICANE ZONE (HVHZ).
2. 2X WOOD FRAMING, 1X OR 2X WOOD BUCK, METAL FRAMING AND CONCRETE/MASONRY OPENING TO BE DESIGNED AND ANCHORED TO PROPERLY TRANSFER ALL LOADS TO STRUCTURE. FRAMING AND CONCRETE/MASONRY OPENING IS THE RESPONSIBILITY OF THE ARCHITECT OR ENGINEER OF RECORD.
3. 1X BUCK OVER CONCRETE/MASONRY IS OPTIONAL. WHEN 1X BUCK IS USED, INSTALLATION ANCHORS WILL PASS THROUGH WINDOW FRAME AND 1X BUCK INTO CONCRETE/MASONRY SUBSTRATE. WHEN USED, 1X BUCKS SHALL BE DESIGNED AND ANCHORED TO PROPERLY TRANSFER ALL LOADS TO STRUCTURE AND IS THE RESPONSIBILITY OF THE ARCHITECT OR ENGINEER OF RECORD. DISSIMILAR MATERIALS MUST BE SEPARATED WITH APPROVED COATING OR MEMBRANE. SELECTION OF COATING OR MEMBRANE IS THE RESPONSIBILITY OF THE ARCHITECT OR ENGINEER OF RECORD. CONCRETE/MASONRY SUBSTRATE. DISSIMILAR MATERIALS MUST BE SEPARATED WITH APPROVED COATING OR MEMBRANE. SELECTION OF COATING OR MEMBRANE IS THE RESPONSIBILITY OF THE ARCHITECT OR ENGINEER OF RECORD.
4. THE PRODUCT SHOWN HEREIN HAS BEEN TESTED TO TAS 201, TAS 202 AND TAS 203. SEE TEST REPORT NO. NCTL-110-21458-1, DATED 10/18/18 BY NATIONAL CERTIFIED TESTING LABORATORIES, YORK, PA, SIGNED AND SEALED BY HAROLD E. RUPP, FLORIDA P.E.
5. MATERIAL:
  - 5.1. FRAME: EXTRUDED RIGID PVC BY VISION EXTRUSIONS GROUP LIMITED PER CURRENT MIAMI-DADE NOTICE OF ACCEPTANCE (NOA).
  - 5.2. REINFORCEMENT:
    - 5.2.1. GALVANIZED STEEL BAR (0.72" X 0.355", Fy = 30-50 ksi & Fu = 37.5-68.7 ksi) - ACTIVE STILES
    - 5.2.2. GALVANIZED STEEL C-CHANNEL (0.73" X 0.434" X 0.060" THICK, Fy = 30-50 ksi & Fu = 37.5-68.7 ksi) - RAILS AND FIXED MEETING STILE.
    - 5.2.3. GALVANIZED STEEL TUBE (0.935" X 0.73" X 0.060" THICK, Fy = 30-50 ksi & Fu = 37.5-68.7 ksi) - FIXED MEETING STILE
  - 5.3. LAMINATE GLASS INTERLAYER: TROSIFOL INTERLAYER BY KURARAY AMERICA, INC. PER CURRENT MIAMI-DADE NOTICE OF ACCEPTANCE (NOA).
6. GLAZING:
  - 6.1. GLAZING DETAIL AS TESTED:
    - 6.1.1. OVERALL: 7/8" NOMINAL INSULATING LAMINATED GLASS.
    - 6.1.2. GLASS THICKNESS: (1) LITE OF 1/8" NOMINAL TEMPERED GLASS TO THE INTERIOR AND (1) LITE OF LAMINATED GLASS TO THE EXTERIOR.
    - 6.1.3. LAMINATED LITE: (2) LITES OF 1/8" NOMINAL ANNEALED GLASS SEPARATED BY A 0.090" TROSIFOL INTERLAYER BY KURARAY AMERICA, INC.
    - 6.1.4. SPACER TYPE/SIZE: CARDINAL XL EDGE 7/16" STAINLESS STEEL SPACER (TYPE SS-D)
    - 6.1.5. GLAZING SYSTEM: INTERIOR GLAZED WITH (2)-LEAF DUAL DUROMETER AND SIKA FLEX "552" BACKBEDDING WITH A SNAP-IN (2)-LEAF DUAL DUROMETER RIGID VINYL GLAZING BEAD.
  - 6.2. ALL SETTING BLOCKS AND GASKET MATERIALS SHALL BE IN COMPLIANCE WITH THE CURRENT EDITION OF THE FLORIDA BUILDING CODE. SETTING BLOCKS SHALL BE NEOPRENE WITH A 70 TO 90 SHORE A DUROMETER. GASKET MATERIALS SHALL BE EDPM WITH A MINIMUM 60 SHORE A DUROMETER.
  - 6.3. AS TESTED GLAZING MEETS ASTM E1300-09e FOR THE DESIGN CONDITIONS SHOWN IN THIS PRODUCT APPROVAL DOCUMENT.
7. APPROVED IMPACT PROTECTIVE SYSTEM IS NOT REQUIRED FOR THIS PRODUCT IN WIND BORNE DEBRIS REGIONS INCLUDING THE HVHZ.
8. SHIM AS REQUIRED AT EACH INSTALLATION ANCHOR WITH LOAD BEARING SHIM. SHIM WHERE SPACE OF 1/16" OR GREATER OCCURS. MAXIMUM ALLOWABLE SHIM STACK TO BE 1/4".
9. FOR ANCHORING INTO CONCRETE/MASONRY USE 1/4" HEX HEAD TAPCONS WITH SUFFICIENT LENGTH TO ACHIEVE A 1 1/2" MINIMUM EMBEDMENT INTO CONCRETE WITH 1 1/2" MINIMUM EDGE DISTANCE AND 1" MINIMUM EMBEDMENT INTO MASONRY WITH 2" MINIMUM EDGE DISTANCE. LOCATE ANCHORS AS SHOWN IN ELEVATIONS AND INSTALLATION DETAILS. 4" MINIMUM SPACING BETWEEN ADJACENT ANCHORS REQUIRED. ANCHOR LOCATIONS HAVE +/- 1" TOLERANCE.
10. FOR ANCHORING INTO WOOD FRAMING OR 2X BUCK USE ONE OF THE FOLLOWING:
  - 10.1. #12 PAN HEAD WOOD SCREWS WITH SUFFICIENT LENGTH TO ACHIEVE A 1 3/8" MINIMUM EMBEDMENT INTO SUBSTRATE WITH 7/8" MINIMUM EDGE DISTANCE AND MINIMUM ANCHOR-TO-ANCHOR SPACING OF 2" ON CENTER. LOCATE ANCHORS AS SHOWN IN ELEVATIONS AND INSTALLATION DETAILS. ANCHOR LOCATIONS HAVE +/- 1" TOLERANCE.
  - 10.2. #14 PAN HEAD WOOD SCREWS WITH SUFFICIENT LENGTH TO ACHIEVE A 1 1/2" MINIMUM EMBEDMENT INTO SUBSTRATE WITH 1" MINIMUM EDGE DISTANCE AND MINIMUM ANCHOR-TO-ANCHOR SPACING OF 2" ON CENTER. LOCATE ANCHORS AS SHOWN IN ELEVATIONS AND INSTALLATION DETAILS. ANCHOR LOCATIONS HAVE +/- 1" TOLERANCE.
11. FOR ANCHORING INTO METAL STRUCTURE USE #14 PAN OR HEX HEAD SMS OR SELF DRILLING SCREWS WITH SUFFICIENT LENGTH TO ACHIEVE 3 THREADS MINIMUM BEYOND STRUCTURE INTERIOR WALL WITH 3/4" MINIMUM EDGE DISTANCE AND MINIMUM ANCHOR-TO-ANCHOR SPACING OF 2" ON CENTER. LOCATE ANCHORS AS SHOWN IN ELEVATIONS AND INSTALLATION DETAILS. ANCHOR LOCATIONS HAVE +/- 1" TOLERANCE.
12. ALL FASTENERS TO BE CORROSION RESISTANT OR HAVE A CORROSION RESISTANT COATING
13. INSTALLATION ANCHORS SHALL BE INSTALLED IN ACCORDANCE WITH ANCHOR MANUFACTURER'S INSTALLATION INSTRUCTIONS AND ANCHORS SHALL NOT BE USED IN SUBSTRATES WITH STRENGTHS LESS THAN THE MINIMUM STRENGTH SPECIFIED BELOW:
  - 13.1. WOOD - MINIMUM SPECIFIC GRAVITY OF (G) 0.42 (NON-HVHZ) AND 0.55 (HVHZ)
  - 13.2. CONCRETE - MINIMUM COMPRESSIVE STRENGTH OF 2500 PSI
  - 13.3. MASONRY - STRENGTH CONFORMANCE TO ASTM C-90, MEDIUM WEIGHT WITH DENSITY > 117 PCF
  - 13.4. METAL STRUCTURE: STEEL 18GA (0.0428"), Fy = 33KSI / Fu = 45 KSI OR ALUMINUM 6063-T5 0.048" THICK MINIMUM
    - 13.4.1. STEEL SUBSTRATE TO MEET MINIMUM FBC HVHZ CODE REQUIREMENTS.
14. APPROVED CONFIGURATIONS: XOX, OX AND XO. OX AND XO INSTALLATION MUST MEET THE FOLLOWING PARAMETERS.
  - 14.1. FRAME HEIGHT WILL NOT EXCEED THAT OF THE XOX. OPERABLE SASH SIZE WILL NOT EXCEED THAT OF THE XOX. FRAME WIDTH WILL BE LIMITED BY SASH SIZE AND DLO LIMITATIONS.
  - 14.2. DAYLIGHT OPENING (DLO) WILL BE THE SAME AS OR LESS THAN THAT SHOWN ON SHEET 2.
  - 14.3. ANCHOR LOCATION AND QUANTITIES USED IN INSTALLATION WILL MEET OR EXCEED THOSE REQUIRED OF THE XOX.
  - 14.4. WEEP HOLE QUANTITY, LOCATION AND SPACING WILL MEET THOSE OF THE XOX. SPACING CAN BE REDUCED AS NEEDED DUE TO THE LOWER FRAME WIDTH.

TABLE OF CONTENTS	
SHEET	DESCRIPTION
1	NOTES
2	ELEVATION & ANCHOR LOCATION
3	VERTICAL INSTALLATION DETAILS
4	HORIZONTAL INSTALLATION DETAILS
5	BILL OR MATERIALS

PROJECT #422-0616	UPDATED REFERENCES	5/31/23	RJA
	UPDATED TO CURRENT FBC	10/27/20	RJA
	REVISED NOTES	5/3/19	RJA
	DESCRIPTION	DATE	BY
C	B	A	REV

**REGENCY PLUS, INC.**  
2000 LOCUST GAP HIGHWAY  
MT. CARMEL, PA 17851

TITLE: SERIES TECH 5505 VINYL HORIZONTAL SLIDING (XOX) WINDOW

DATE: 12/5/18  
DRAWING NO: RPLS0077  
SHEET: 1 OF 5

PREPARED BY:   
SCALE: N.T.S.  
REV: C

Robert J. Amoruso, P.E.  
Florida P.E. No. 49752

PTC Product Design Group, LLC  
PO Box 520775  
Longwood, FL 32752-0775  
321-690-1788 info@ptc-corp.com  
FBPE Certificate of Authorization  
No. 25935

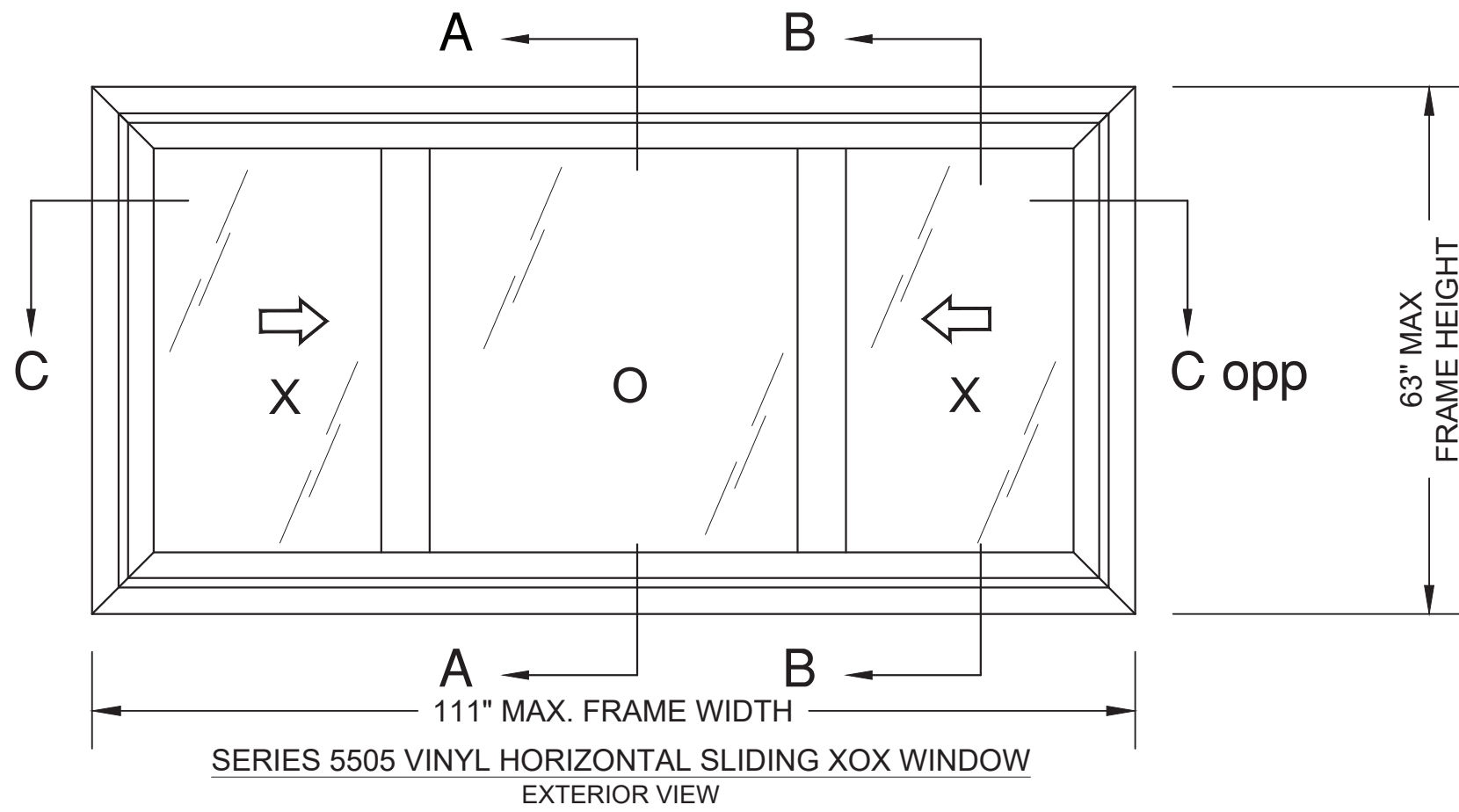

DESIGN PRESSURE RATING (PSF)	IMPACT RATING
+55.0/-55.0	LARGE MISSILE IMPACT (SMALL MISSILE ENVELOPED)

- NOTES:
- MAXIMUM ACTIVE PANEL SIZE: 32" X 59-7/8"
  - DAYLIGHT OPENING SIZE:
    - ACTIVE.: 28-3/4" X 56-5/8"
    - FIXED: 41" X 57-1/2"
  - WEEP HOLE SIZE AND LOCATIONS
    - INTERIOR SILL
      - SIZE: 19.05 MM (0.75") WIDE BY 4.57 MM (0.180") HIGH NOTCH
      - LOCATION: EACH END AND 800MM (31.5") FROM EACH END OF THE INTERIOR SILL INSERT
    - EXTERIOR SILL
      - 19.05 MM (0.75") WIDE BY 6.35 MM (0.25") HIGH NOTCH
      - LOCATION: EACH END OF THE EXTERIOR SILL TRACK
    - INTERIOR SILL
      - SIZE: 9.53 MM (0.375") DIAMETER
      - LOCATION: 419 MM (16.5") AND 826 MM (32.5") FROM EACH END AND MIDSPAN OF THE INTERIOR SILL TRACK
    - EXTERIOR SILL
      - SIZE: 25.4 MM (1") WIDE BY 6.35 MM (0.25") HIGH
      - LOCATION: EACH END OF THE EXTERIOR SILL TRACK
    - EXTERIOR SILL
      - SIZE: 32 MM (1.25") WIDE BY 6.35 MM (0.25") HIGH WITH PLASTIC WEEP COVER
      - LOCATION: 76 MM (3") FROM EACH END OF THE EXTERIOR SILL FACE

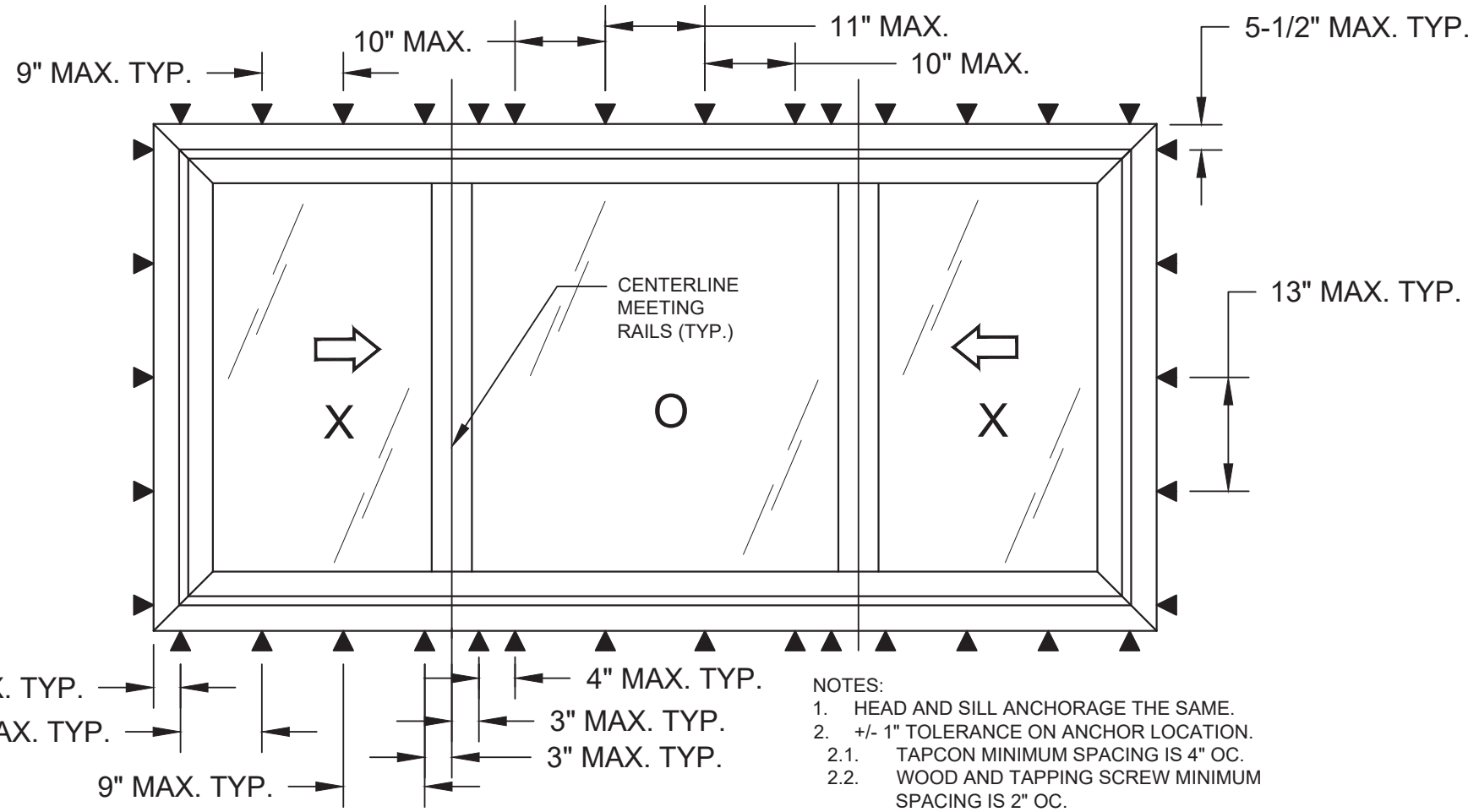

- NOTES:
- HEAD AND SILL ANCHORAGE THE SAME.
  - +/- 1" TOLERANCE ON ANCHOR LOCATION.
    - TAPCON MINIMUM SPACING IS 4" OC.
    - WOOD AND TAPPING SCREW MINIMUM SPACING IS 2" OC.

PROJECT #422-0616	5/31/23	RJA	BY
	10/27/20	RJA	DATE
	5/3/19	RJA	DESCRIPTION
UPDATED REFERENCES	UPDATED TO CURRENT FBC	REVISED NOTES	DESCRIPTION
C	B	A	REV

**REGENCY PLUS, INC.**  
 2000 LOCUST GAP HIGHWAY  
 MT. CARMEL, PA 17851  
 TITLE: SERIES TECH 5505 VINYL HORIZONTAL SLIDING (XOX) WINDOW  
 ELEVATION AND ANCHOR LOCATIONS

DATE:	12/5/18
DRAWING NO.:	RPLS0077
DRAWN BY:	RJA
SCALE:	N.T.S.
REV:	C
SHEET:	2 OF 5

PREPARED BY:

Robert J. Amoruso, P.E.  
Florida P.E. No. 49752

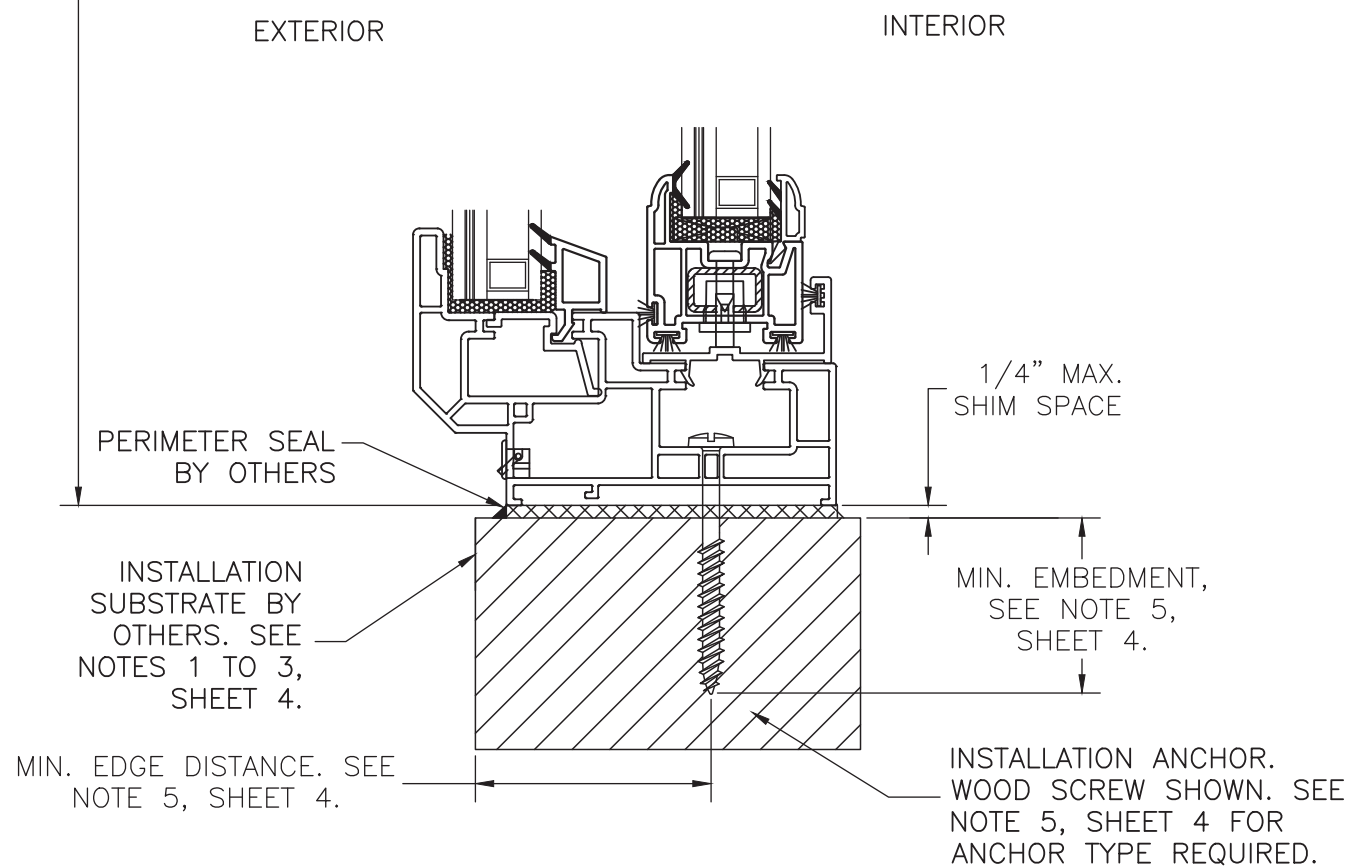
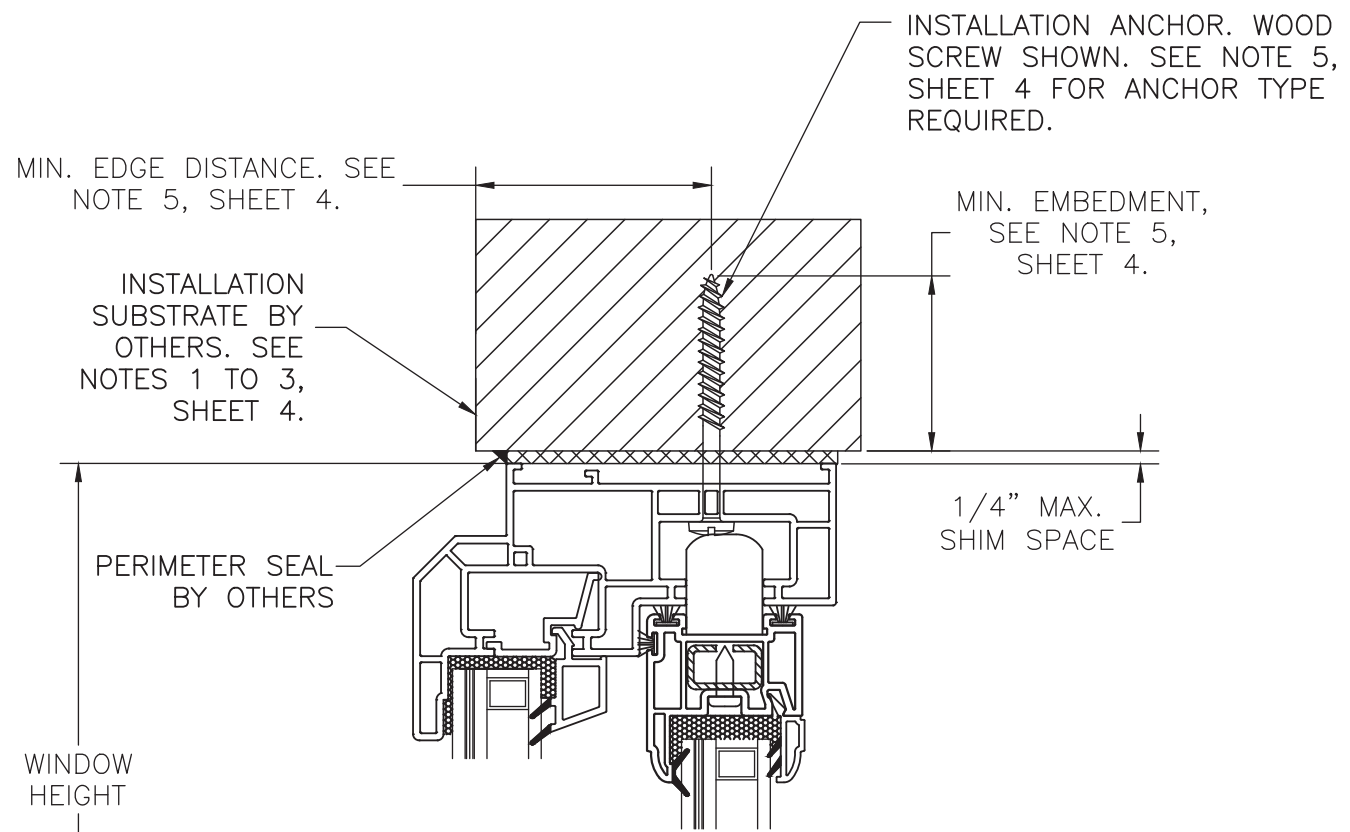

**VERTICAL CROSS SECTION A-A**  
 WOOD FRAMING, 2X WOOD BUCK,  
 CONCRETE/MASONRY OR METAL FRAME  
 APPROVED

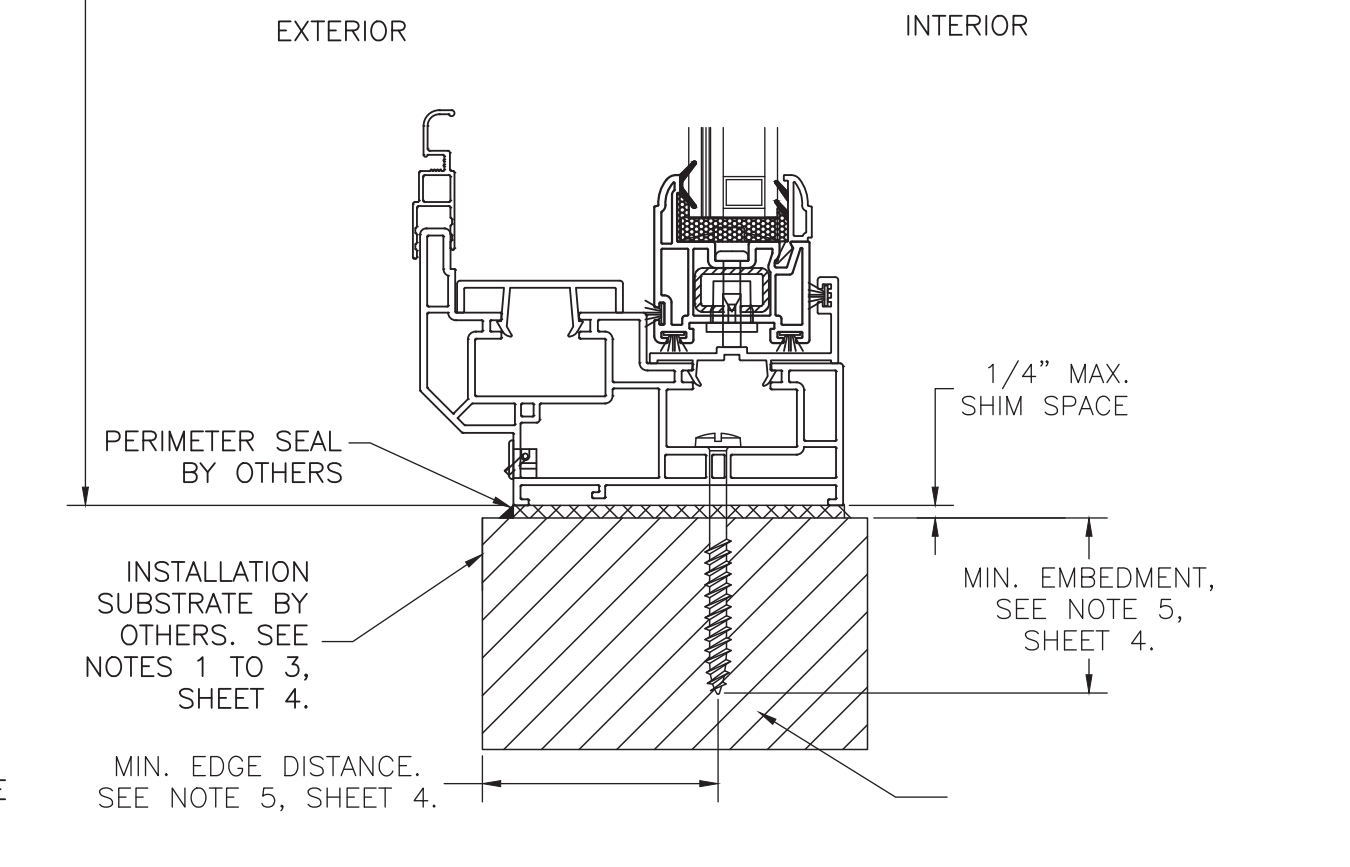
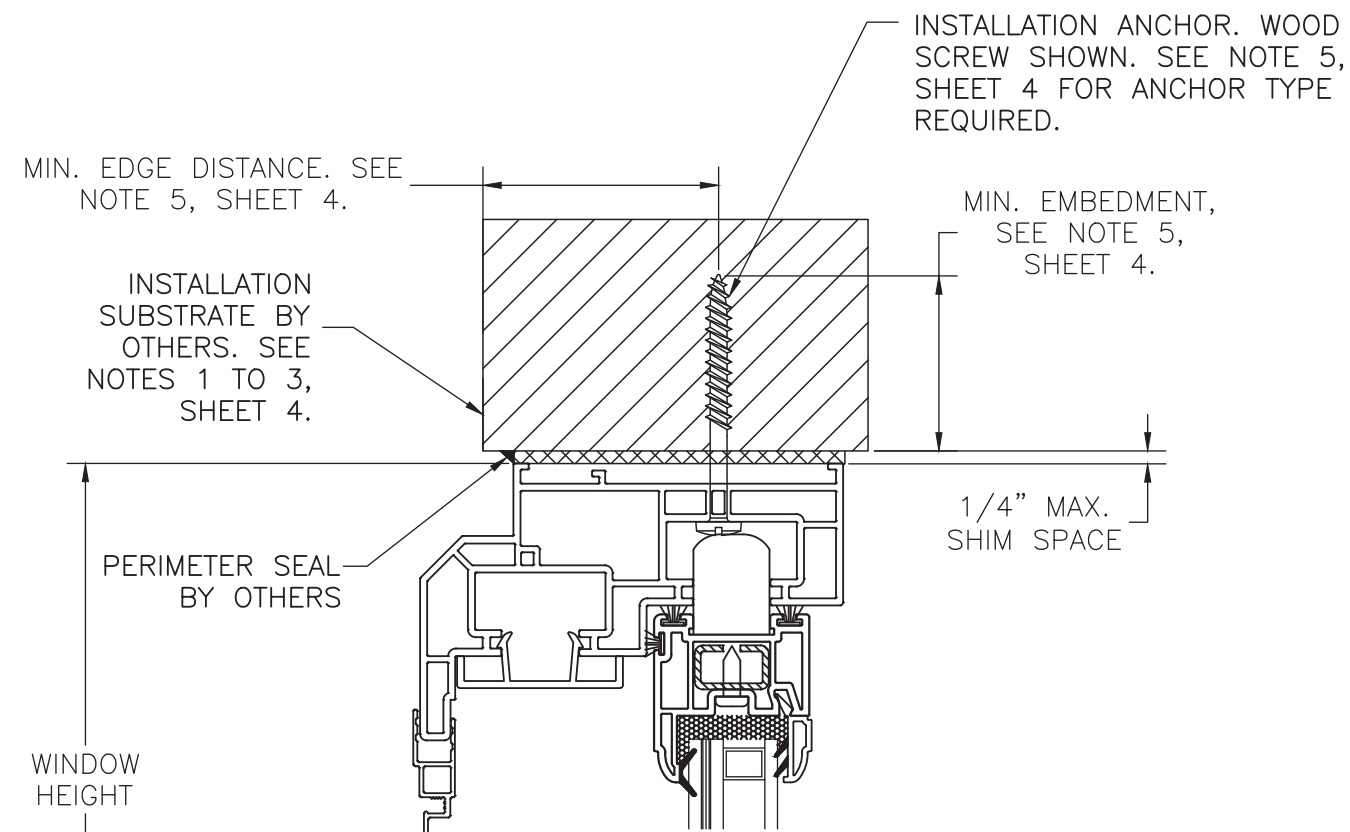

**VERTICAL CROSS SECTION B-B**  
 WOOD FRAMING, 2X WOOD BUCK,  
 CONCRETE/MASONRY OR METAL FRAME  
 APPROVED

PROJECT #422-0616

REV	DESCRIPTION	DATE	BY
C	UPDATED REFERENCES	5/31/23	RJA
B	UPDATED TO CURRENT FBC	10/27/20	RJA
A	REVISED NOTES	5/3/19	RJA

**REGENCY PLUS, INC.**  
 2000 LOCUST GAP HIGHWAY  
 MT. CARMEL, PA 17851

TITLE: SERIES TECH 5505 VINYL HORIZONTAL SLIDING (XOX) WINDOW  
 VERTICAL INSTALLATION DETAILS

DATE: 12/5/18  
 DRAWING NO: RPLS0077  
 SHEET: 3 OF 5

PREPARED BY: **FBPE**

SCALE: N.T.S.  
 REV: C

Robert J. Amoruso, P.E.  
 Florida P.E. No. 49752

**INSTALLATION NOTES:**

1. APPROVED INSTALLATION SUBSTRATES INCLUDE THE FOLLOWING:
  - 1.1. WOOD FRAMING,
  - 1.2. STEEL STUD FRAMING,
  - 1.3. ALUMINUM FRAMING, AND
  - 1.4. CONCRETE AND/OR MASONRY.
2. 2X WOOD FRAMING, 1X OR 2X WOOD BUCK, METAL FRAMING AND CONCRETE/MASONRY OPENING TO BE DESIGNED AND ANCHORED TO PROPERLY TRANSFER ALL LOADS TO STRUCTURE. FRAMING AND CONCRETE/MASONRY OPENING IS THE RESPONSIBILITY OF THE ARCHITECT OR ENGINEER OF RECORD.
3. 1X BUCK OVER CONCRETE/MASONRY IS OPTIONAL. WHEN 1X BUCK IS USED, INSTALLATION ANCHORS WILL PASS THROUGH WINDOW FRAME AND 1X BUCK INTO CONCRETE/MASONRY SUBSTRATE. WHEN USED, 1X BUCKS SHALL BE DESIGNED AND ANCHORED TO PROPERLY TRANSFER ALL LOADS TO STRUCTURE AND IS THE RESPONSIBILITY OF THE ARCHITECT OR ENGINEER OF RECORD. DISSIMILAR MATERIALS MUST BE SEPARATED WITH APPROVED COATING OR MEMBRANE. SELECTION OF COATING OR MEMBRANE IS THE RESPONSIBILITY OF THE ARCHITECT OR ENGINEER OF RECORD.
4. SHIM AS REQUIRED AT EACH INSTALLATION ANCHOR WITH LOAD BEARING SHIM. SHIM WHERE SPACE OF 1/16" OR GREATER OCCURS. MAXIMUM ALLOWABLE SHIM STACK TO BE 1/4".
5. SUBSTRATE ANCHORING METHODS:
  - 5.1. FOR ANCHORING INTO CONCRETE/MASONRY USE 1/4" HEX HEAD TAPCONS WITH SUFFICIENT LENGTH TO ACHIEVE A 1 1/2" MINIMUM EMBEDMENT INTO CONCRETE WITH 1 1/2" MINIMUM EDGE DISTANCE AND 1" MINIMUM EMBEDMENT INTO MASONRY WITH 2" MINIMUM EDGE DISTANCE. LOCATE ANCHORS AS SHOWN IN ELEVATIONS AND INSTALLATION DETAILS. 4" MINIMUM SPACING BETWEEN ADJACENT ANCHORS REQUIRED. ANCHOR LOCATIONS HAVE +/- 1" TOLERANCE.
  - 5.2. FOR ANCHORING INTO WOOD FRAMING OR 2X BUCK USE ONE OF THE FOLLOWING:
    - 5.2.1. #12 PAN HEAD WOOD SCREWS WITH SUFFICIENT LENGTH TO ACHIEVE A 1 3/8" MINIMUM EMBEDMENT INTO SUBSTRATE WITH 7/8" MINIMUM EDGE DISTANCE AND MINIMUM ANCHOR-TO-ANCHOR SPACING OF 2" ON CENTER. LOCATE ANCHORS AS SHOWN IN ELEVATIONS AND INSTALLATION DETAILS. ANCHOR LOCATIONS HAVE +/- 1" TOLERANCE.
    - 5.2.2. #14 PAN HEAD WOOD SCREWS WITH SUFFICIENT LENGTH TO ACHIEVE A 1 1/2" MINIMUM EMBEDMENT INTO SUBSTRATE WITH 1" MINIMUM EDGE DISTANCE AND MINIMUM ANCHOR-TO-ANCHOR SPACING OF 2" ON CENTER. LOCATE ANCHORS AS SHOWN IN ELEVATIONS AND INSTALLATION DETAILS. ANCHOR LOCATIONS HAVE +/- 1" TOLERANCE.
  - 5.3. FOR ANCHORING INTO METAL STRUCTURE USE #14 PAN OR HEX HEAD SMS OR SELF DRILLING SCREWS WITH SUFFICIENT LENGTH TO ACHIEVE 3 THREADS MINIMUM BEYOND STRUCTURE INTERIOR WALL WITH 3/4" MINIMUM EDGE DISTANCE AND MINIMUM ANCHOR-TO-ANCHOR SPACING OF 2" ON CENTER. LOCATE ANCHORS AS SHOWN IN ELEVATIONS AND INSTALLATION DETAILS. ANCHOR LOCATIONS HAVE +/- 1" TOLERANCE.
6. INTERIOR AND EXTERIOR FINISHES BY OTHERS. NOT SHOWN FOR CLARITY.
7. PERIMETER AND JOINT SEALANT BY OTHERS TO BE DESIGNED AND/OR SPECIFIED IN ACCORDANCE WITH ASTM E2112.

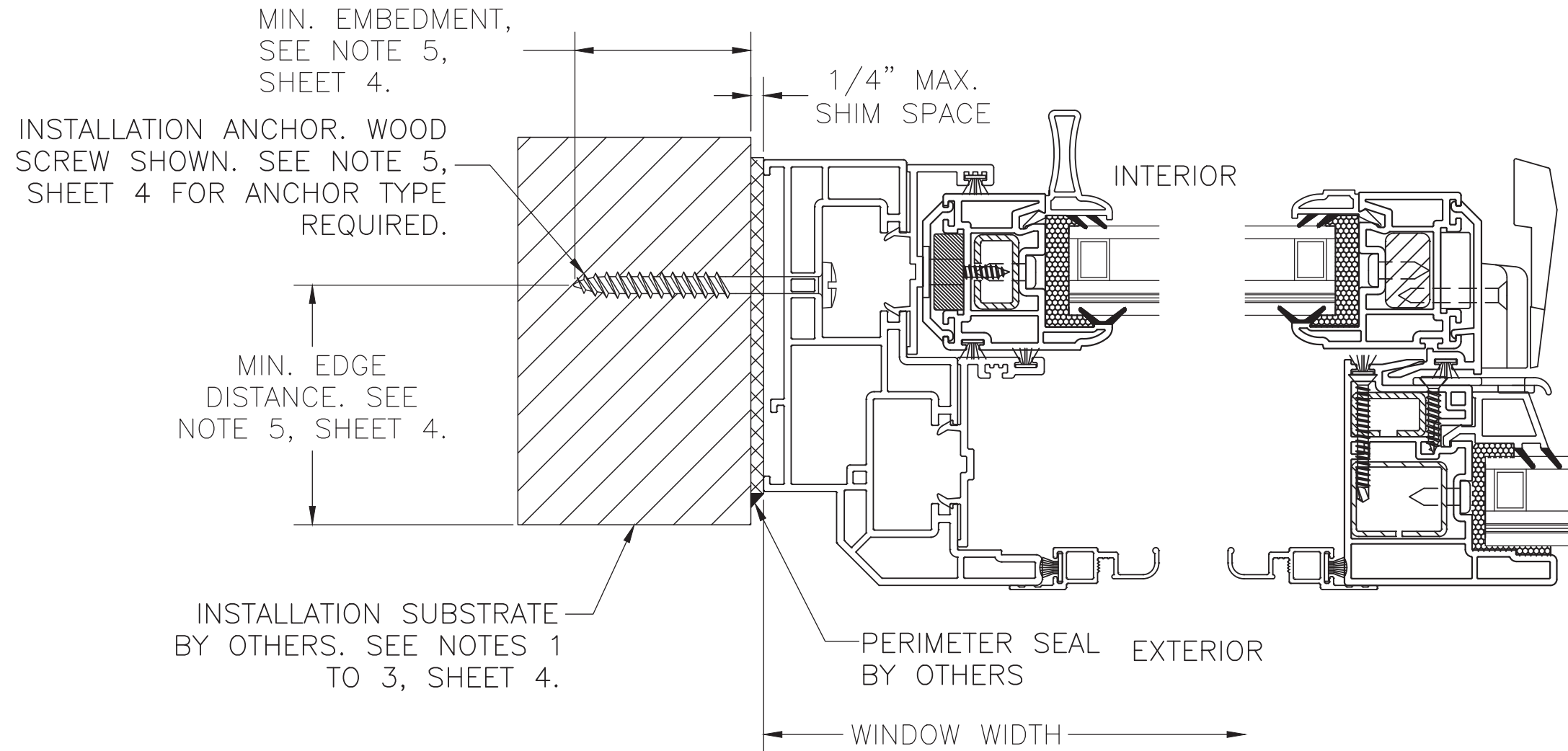

HORIZONTAL (JAMB) CROSS SECTION C-C  
 WOOD FRAMING, 2X WOOD BUCK, CONCRETE/MASONRY  
 OR METAL FRAME APPROVED

PROJECT #422-0616	5/31/23	RJA	BY				
	10/27/20	RJA	DATE				
	5/3/19	RJA	DATE				
C	UPDATED REFERENCES	B	UPDATED TO CURRENT FBC	A	REVISED NOTES	REV	DESCRIPTION

**REGENCY PLUS, INC.**  
 2000 LOCUST GAP HIGHWAY  
 MT. CARMEL, PA 17851

TITLE: SERIES TECH 5505 VINYL HORIZONTAL SLIDING (XOX) WINDOW HORIZONTAL INSTALLATION DETAILS

DATE: 12/5/18  
 DRAWING NO: RPLS0077  
 SHEET: 4 OF 5

PREPARED BY: **PTC**

DRAWN BY: RJA  
 SCALE: N.T.S.  
 REV: C

Robert J. Amoruso, P.E.  
 Florida P.E. No. 49752



**Series Tech 5505 XOX 3-Lite Impact Slider / Bill of Material**

Supplier	Part Numbers	Description	Quantity	Supplier	Part Numbers	Description	Quantity
VISION EXTR. GRP. LTD	IV White 1060 / 7720	Master Frame (H)	2	Hygrade Metals	ST-226-144-0.052	Impost Mullion (H)	2
VISION EXTR. GRP. LTD	IV White 1060 / 7720	Master Frame (W)	2	Hygrade Metals	ST-888-168-0.062	Impost Mullion (H)	2
VISION EXTR. GRP. LTD	IV White 1073 / 7724	Pocket Cover Heights / Vents (W)	2	Joseph Fazzio Steel	615242-120-Solid	Operating Sash Lock Side / (H-1)	2
VISION EXTR. GRP. LTD	IV White 1073 / 7724	Pocket Cover Heights / (W)	1	Product Design	H-884	Screen Clip Clear	4
VISION EXTR. GRP. LTD	IV White 1073 / 7724	Pocket Cover Heights / Vents (H)	4	Product Design	H-3150	Screen Clip Clear	2
VISION EXTR. GRP. LTD	IV White 1070 / 7736	Sash Stop Frame Cover / Vents (W)	2	Product Design	H-808WHZ	Weep Hole Cover White	2
VISION EXTR. GRP. LTD	IV White 1079 / 7737	Pocket Insert / Center Section PW (W)	2	Product Design	WR03-R3	Stainless Steel Ball Bearing Rollers	4
VISION EXTR. GRP. LTD	IV White 1103 / 7726	PW Glazing Bead (Fixed Center Section) (W)	2	Industrial Sales	VEN-VG-1208B	Black Glazing Tape 1/8 x 3/8 x 85' (Fixed Center Section)	4
VISION EXTR. GRP. LTD	IV White 1080 / 7753	PW Glazing Bead (Fixed Center Section) (H)	2	RH Products	HH-66 Vinyl Cement	Interlock Cover (Operating Sash) / Vents (H)	2
VISION EXTR. GRP. LTD	IV White 1063 / 7735	Impost Mullion (Fixed Center Section) (H)	2	S.I.L. Plastic	00156-C001	Liftrail End Caps White	4
VISION EXTR. GRP. LTD	IV White 1282 / 7750	Sash Frame (Operating Sash) / Vents (H)	4	Smith Staple	BEA 80/10	Stainless Steel Staples 3/8 x 1/2 Sash (W)	16
VISION EXTR. GRP. LTD	IV White 1282 / 7750	Sash Frame (Operating Sash) / Vents (W)	4	Lindenmeyr	W0511022	30PP12-18P50-9/16 X1 3/8 X 3 Foam Block	2
VISION EXTR. GRP. LTD	IV White 1067 / 7745	Glazing Bead Stop (Operating Sash) / Vents (W)	4	James Spring Wire	CS025	Hurricane Grade Spring	4
VISION EXTR. GRP. LTD	IV White 1067 / 7745	Glazing Bead Stop (Operating Sash) / Vents (H)	2	Novagard Silicones	02-MX0150010C2	Accessory Parts Installation Translucent	1
VISION EXTR. GRP. LTD	IV White 1068 / 7747	Glazing Liftrail Handle (Operating Sash) / Vents (H)	2	Sika US	552 Sikaflex Black	Wet Glaze (Operating Sash) / (Fixed Center Section)	3
VISION EXTR. GRP. LTD	IV White 1180 / 7727	Interlock Cover (Operating Sash) / Vents (H)	2	Vision Industries	1057A-003-EW	Hurricane Tilt Latch	4
VISION EXTR. GRP. LTD	IV White 1078 / 7725	Sash Cover (Operating Sash) / Vents (H)	2	Vision Industries	3220SS-003-EW	Safe Seal Lock	4
Ultra-Fab	W23303NW0000	.210 x .300 Fin Seal Pocket Cover (W) / 1073 / 7724	3	Vision Industries	8292A-003-EW	Safe Seal Keeper	4
Ultra-Fab	W23303NW0000	.210 x .300 Fin Seal Pocket Cover (H) / 1073 / 7724	4	Frank Lowe	2NB-8K-0.125-032-064	Glass Setting Blocks Sash (W) Top / Sash (H)	8
Ultra-Fab	W23303NW0000	.210 x .300 Fin Seal Impost Mullion (H) / 1063 / 7735	2	Frank Lowe	2NB-8K-0.125-032-064	Glass Setting Blocks Fixed (W) Base	2
Ultra-Fab	W23301NW0000	.187 x .300 Fin Seal Interlock Cover (H) / 1180 / 7727	2	Frank Lowe	2NB-8K-0.125-028-028	Glass Setting Blocks Sash (W) Base	4
Ultra-Fab	W23301NW0000	.187 x .300 Fin Seal Interlock Cover (Top / Blocks) / 1180 / 7727	4	GLF Corporation	137341	# 8-18 x 0.850 Flat Wafer Shoulder / Sash / Hurricane Latch	4
Ultra-Fab	W23301NW0000	.187 x .300 Fin Seal Sash Frame (H) / 1282 / 7750 / Energi	4	GLF Corporation	120376	# 8 x 1 1/4" Tek White / Locks	8
Ultra-Fab	W23301NW0000	.187 x .300 Fin Seal Sash Frame (W) / 1282 / 7750 / Exterior Top	2	GLF Corporation	116821	# 6 x 1" Tek White / Keepers	8
Ultra-Fab	W23223NW0000	.210 x .220 Fin Seal Sash Frame (W) / 1282 / 7750 / Exterior Base	2	GLF Corporation	156180	# 6 x 1 1/4" Tek White / Impost Mullion Rebar (H)	14
Ultra-Fab	W112257W0000	.270 x .220 Fin Seal Sash Frame (H) / Single Leg Screen Frame	4	GLF Corporation	120913	# 8 x 3 1/2" Phil Pan HD SMS Salt Spray / Impost Mullion (H)	8
Shapes Unlimited	06516NEW192	Single Leg Frame New White	6	GLF Corporation	145030	# 0625 x 0.194 Washer / Impost Mullion (H)	8
Shapes Unlimited	06515NEW192	Double Leg Frame New White	2	GLF Corporation	117595	# 6 x 5/8" Tek / Impost Mullion Rebar (H)	18
Adept	2584	Tension Springs	4	GLF Corporation	117595	# 6 x 5/8" Tek / Sash Rebar (H)	32
Phifer	3002606	Fiberglass Screen Cloth Charcoal / 28" x 600'	2	GLF Corporation	117595	# 6 x 5/8" Tek / Sash Rebar (W)	16
Imperial Plastic USA	EX-FLX-Q165-BK	Screen Spline (H / W)	8	GLF Corporation	116506	# 5 x 3/8" Tek / Screen Clips White	6
Hygrade Metals	CK252X260	Aluminum Corner Keys	8	Cardinal	Hurricane Laminate Impact	Operating Vent Sash E366 2.7mm / 0.9.0 PVB Interlayer IG	2
Hygrade Metals	ST-226-144-0.052	Operating Sash / (W-2)-(H-1)	6	Cardinal	Hurricane Laminate Impact	Fixed Center Section Sash E366 2.7mm / 0.9.0 PVB Interlayer IG	1

PROJECT #422-06'16	RJA	RJA	RJA	BY
	5/31/23	10/27/20	5/3/19	DATE
	UPDATED REFERENCES	UPDATED TO CURRENT FBC	REVISED NOTES	DESCRIPTION
	C	B	A	REV

**REGENCY PLUS, INC.**  
 2000 LOCUST GAP HIGHWAY  
 MT. CARMEL, PA 17851

TITLE: SERIES TECH 5505 VINYL HORIZONTAL SLIDING (XOX) WINDOW  
 BILL OF MATERIALS

DATE: 12/5/18  
 DRAWING NO: RPLS0077  
 SHEET: 5 OF 5

DRAWN BY: RJA  
 SCALE: N.T.S.  
 REV: C



Robert J. Amoruso, P.E.  
 Florida P.E. No. 49752