

GLASS TYPE 'A'
7/16" OVERALL LAM. GLASS

GLASS TYPE 'B'
7/8" OVERALL INSUL. LAM. GLASS

GLAZING OPTIONS

1/4" AIR SPACE CONSISTING OF:

- SPACER:**
'HELIMA' LOW PROFILE ALUMINUM SPACER BY 'LINGERMANN GMBH' AROUND THE PERIMETER OF THE GLASS.
PERIMETER SEALANT:
SILICONE
DOWSIL 791
GE 2000
OR
'DURASEAL' EDGE SEAL SYSTEM BY 'QUANEX'

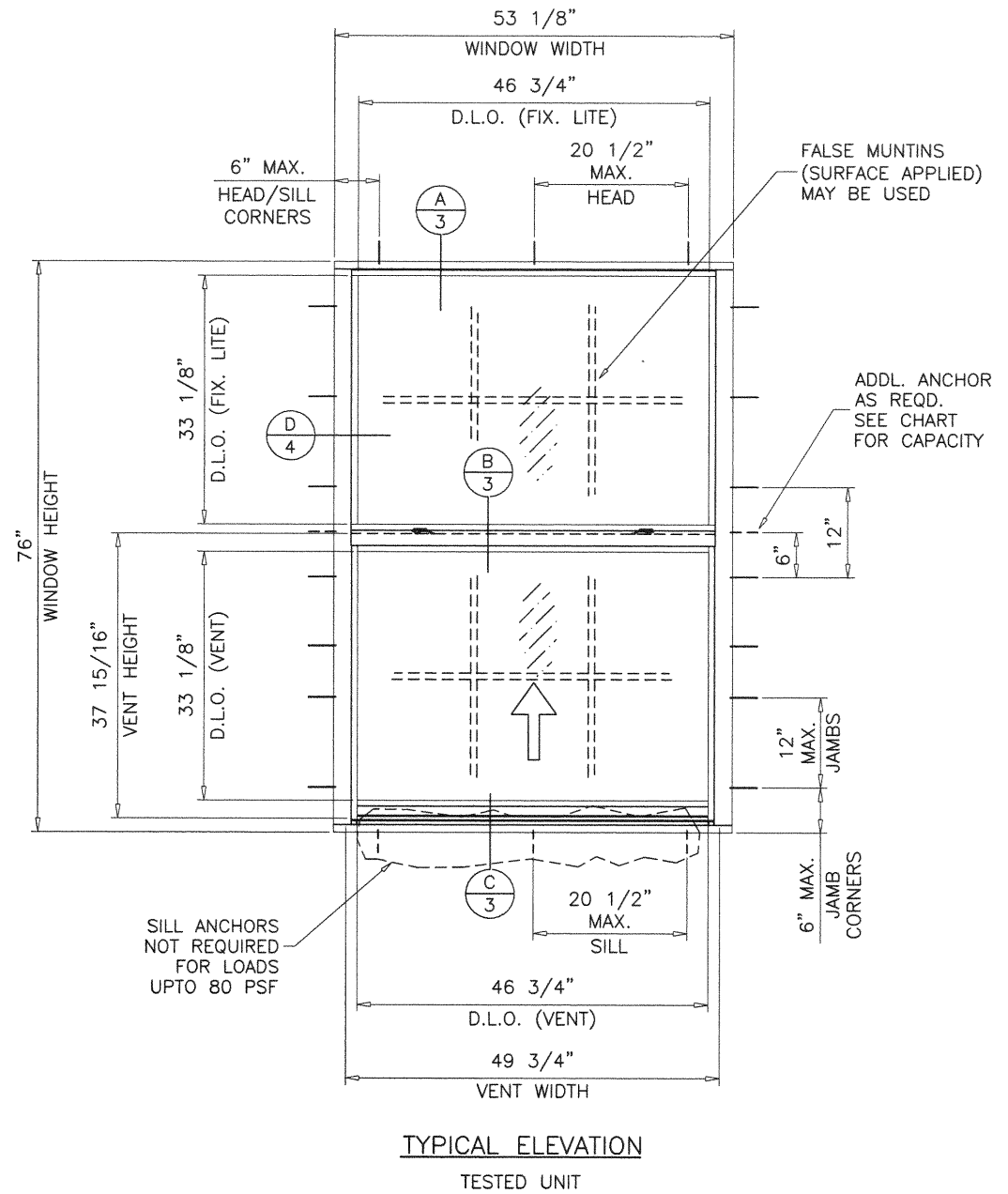

TYPICAL ELEVATION
TESTED UNIT

Sealed: 8/12/2020

THESE WINDOWS ARE RATED FOR SMALL MISSILE IMPACT. F.B.C. APPROVED IMPACT RESISTANT SHUTTERS REQUIRED FOR INSTALLATIONS UP TO 30 FT. OF GRADE. SHUTTERS NOT REQD. FOR INSTALLATIONS ABOVE 30 FT. OF GRADE.

- A- CONTRACTOR TO BE RESPONSIBLE FOR THE SELECTION, PURCHASE AND INSTALLATION OF THIS PRODUCT BASED ON THIS PRODUCT EVALUATION PROVIDED HE/SHE DOES NOT DEVIATE FROM THE CONDITIONS DETAILED ON THIS DOCUMENT.
- B- THIS PRODUCT EVALUATION DOCUMENT WILL BE CONSIDERED INVALID IF ALTERED BY ANY MEANS.
- C- SITE SPECIFIC PROJECTS SHALL BE PREPARED BY A FLORIDA REGISTERED ENGINEER OR ARCHITECT WHICH WILL BECOME THE ENGINEER OF RECORD (E.O.R.) FOR THE PROJECT AND WHO WILL BE RESPONSIBLE FOR THE PROPER USE OF THE P.E.D. ENGINEER OF RECORD, ACTING AS A DELEGATED ENGINEER TO THE P.E.D. ENGINEER SHALL SUBMIT TO THIS LATTER THE SITE SPECIFIC DRAWINGS FOR REVIEW.
- D- THIS P.E.D. SHALL BEAR THE DATE AND ORIGINAL SEAL AND SIGNATURE OF THE PROFESSIONAL ENGINEER OF RECORD THAT PREPARED IT.



SERIES MG-200

ALUMINUM SINGLE HUNG WINDOW

DESIGN LOAD RATINGS FOR THESE WINDOWS TO BE AS PER CHARTS SHOWN ON SHEET 2.

APPROVAL APPLIES TO SINGLE UNITS OR SIDE BY SIDE COMBINATIONS OF S.H./S.H. OR SINGLE HUNG WITH OTHER WINDOW TYPES IN MODULES OF TWO OR MORE WINDOWS USING F.B.C. APPROVED MULLIONS IN BETWEEN. LOWER DESIGN PRESSURE FROM WINDOWS OR MULLION APPROVAL WILL APPLY TO ENTIRE SYSTEM.

THIS PRODUCT HAS BEEN DESIGNED AND TESTED TO COMPLY WITH THE REQUIREMENTS OF THE 2017 (6TH EDITION)/2020 (7TH EDITION) FLORIDA BUILDING CODE INCLUDING HIGH VELOCITY HURRICANE ZONE (HVHZ).

1BY OR 2BY WOOD BUCKS & BUCK FASTENERS BY OTHERS, MUST BE DESIGNED AND INSTALLED ADEQUATELY TO TRANSFER APPLIED PRODUCT LOADS TO THE BUILDING STRUCTURE.

ANCHORS SHALL BE CORROSION RESISTANT, SPACED AS SHOWN ON DETAILS AND INSTALLED PER MANUF'S INSTRUCTIONS. SPECIFIED EMBEDMENT TO BASE MATERIAL SHALL BE BEYOND WALL DRESSING OR STUCCO.

A LOAD DURATION INCREASE IS USED IN DESIGN OF ANCHORS INTO WOOD ONLY.

ALL SHIMS TO BE HIGH IMPACT, NON-METALLIC AND NON-COMPRESSIBLE.

MATERIALS INCLUDING BUT NOT LIMITED TO STEEL/METAL SCREWS, THAT COME INTO CONTACT WITH OTHER DISSIMILAR MATERIALS SHALL MEET THE REQUIREMENTS OF THE 2017/2020 FLORIDA BLDG. CODE & ADOPTED STANDARDS.

THIS PRODUCT APPROVAL IS GENERIC AND DOES NOT PROVIDE INFORMATION FOR A SITE SPECIFIC PROJECT, i.e. LIFE SAFETY OF THIS PRODUCT, ADEQUACY OF STRUCTURE RECEIVING THIS PRODUCT AND SEALING AROUND OPENING FOR WATER INFILTRATION RESISTANCE ETC.

CONDITIONS NOT SHOWN IN THIS DRAWING ARE TO BE ANALYZED SEPARATELY, AND TO BE REVIEWED BY BUILDING OFFICIAL.

DESIGN LOADS SHOWN ARE BASED ON 'ALLOWABLE STRESS DESIGN (ASD)'.

MANUFACTURER'S LABEL SHALL BE LOCATED ON A READILY VISIBLE LOCATION IN ACCORDANCE WITH SECTION 1709.9.3 OF FLORIDA BUILDING CODE. LABELING TO COMPLY WITH SECTION 1709.9.2.

af c
AL-FAROOQ CORPORATION
ENGINEERS & PRODUCT DEVELOPMENT
9360 SUNSET DRIVE, SUITE 220
MIAMI, FLORIDA 33173 (C.A.N. 3538)
TEL. (305) 262-6978 FAX. (305) 262-6978
COMP-ANL\W16-21MG

MG-200 ALUM SINGLE HUNG WINDOW (S.M.I.)
MR-GLASS DOORS & WINDOWS MANUFACTURING, LLC
8051 N.W. 79th Place
Medley, FL. 33166
Tel. (305) 764-3963 Fax. (305) 470-8285

no	date	description
A	01.12.18	UPDATED TO 2017 FBC
B	07.24.20	UPDATED TO 2020 FBC

date:	04-15-16
scale:	1/2"=1'-0"
dr. by:	TARIQ
chk. by:	

drawing no.
W16-21
sheet 1 of 7

EQUAL LITES WINDOWS			
DESIGN LOAD CAPACITY - PSF			
FLANGE DIMS.		GLASS TYPES 'A' & 'B'	
WIDTH	HEIGHT	EXT.(+)	INT.(-)
19-1/8"	26" (4)	80.0	140.0
26-1/2"		80.0	140.0
30"		80.0	140.0
37"		80.0	140.0
48"		80.0	140.0
53-1/8"	38-3/8" (4)	80.0	140.0
19-1/8"		80.0	140.0
26-1/2"		80.0	140.0
30"		80.0	140.0
37"		80.0	140.0
48"	80.0	140.0	
53-1/8"	50-5/8" (6)	80.0	140.0
19-1/8"		80.0	140.0
26-1/2"		80.0	140.0
30"		80.0	140.0
37"		80.0	140.0
48"	80.0	140.0	
53-1/8"	63" (6)	80.0	140.0
19-1/8"		80.0	140.0
26-1/2"		80.0	140.0
30"		80.0	140.0
37"		80.0	140.0
48"	80.0	140.0	
53-1/8"	74-1/4" (8)	80.0	140.0
19-1/8"		80.0	140.0
26-1/2"		80.0	140.0
30"		80.0	140.0
37"		80.0	140.0
48"	80.0	140.0	
53-1/8"	76" (8)	80.0	140.0
19-1/8"		80.0	140.0
26-1/2"		80.0	140.0
30"		80.0	140.0
37"		80.0	140.0
48"	80.0	140.0	
53-1/8"	84" (8)	80.0	128.5
19-1/8"		80.0	140.0
26-1/2"		80.0	140.0
30"		80.0	140.0
37"		80.0	140.0
48"	80.0	140.0	
53-1/8"	74-1/4"	80.0	140.0
19-1/8"		80.0	140.0
26-1/2"		80.0	140.0
30"		80.0	140.0
37"	76"	80.0	140.0
48"		80.0	140.0
53-1/8"	84"	80.0	140.0
19-1/8"		80.0	124.7
26-1/2"	74-1/4"	80.0	140.0
30"		80.0	140.0
37"	76"	80.0	140.0
48"		80.0	140.0
53-1/8"	84"	80.0	140.0
19-1/8"		80.0	140.0
26-1/2"	74-1/4"	80.0	140.0
30"		80.0	140.0
37"	76"	80.0	140.0
48"		80.0	140.0
53-1/8"	84"	80.0	140.0
19-1/8"		80.0	140.0

ADDL. ANCHOR AT MTG. RAIL

NO. IN PARENTHESIS INDICATE NO. OF ANCHORS PER JAMB.

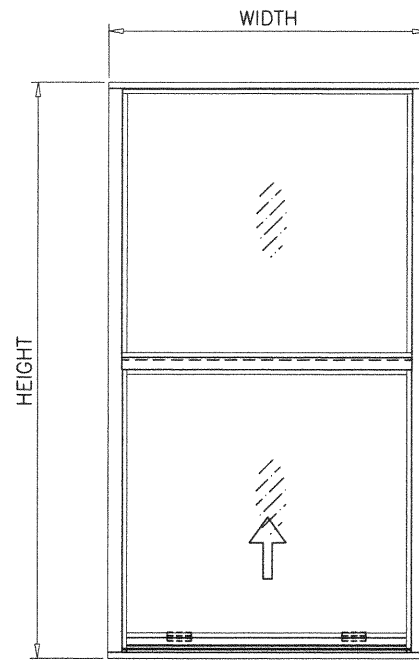

EQUAL LITES

UNEQUAL LITES WINDOWS			
DESIGN LOAD CAPACITY - PSF			
FLANGE DIMS.		GLASS TYPES 'A' & 'B'	
WIDTH	HEIGHT	EXT.(+)	INT.(-)
19-1/8"	50-5/8" (6)	80.0	140.0
26-1/2"		80.0	140.0
30"		80.0	140.0
32"		80.0	140.0
36"		80.0	140.0
37"		80.0	140.0
46"		80.0	140.0
48"		80.0	140.0
53-1/8"		80.0	140.0
19-1/8"		63" (6)	80.0
26-1/2"	80.0		140.0
30"	80.0		140.0
32"	80.0		140.0
36"	80.0		140.0
37"	80.0		140.0
46"	74-1/4" (8)	80.0	140.0
19-1/8"		80.0	140.0
26-1/2"		80.0	140.0
30"		80.0	140.0
32"		80.0	140.0
36"	76" (8)	80.0	140.0
19-1/8"		80.0	140.0
26-1/2"		80.0	140.0
30"		80.0	140.0
32"	84" (8)	80.0	140.0
19-1/8"		80.0	140.0
26-1/2"		80.0	140.0
30"	76"	80.0	140.0
32"		80.0	140.0
36"	84"	80.0	140.0
19-1/8"		80.0	140.0
26-1/2"	76"	80.0	140.0
30"		80.0	140.0
32"	84"	80.0	140.0
19-1/8"		80.0	140.0

NO. IN PARENTHESIS INDICATE NO. OF ANCHORS PER JAMB.

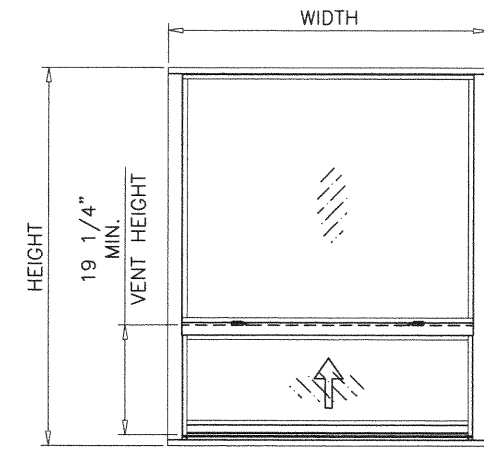

UNEQUAL LITES (ORIEL TYPE)

NOTE:
GLASS CAPACITIES ON THIS SHEET ARE
BASED ON ASTM E1300-09 (3 SEC. GUSTS)
AND FLORIDA BUILDING COMMISSION
DECLARATORY STATEMENT DCA05-DEC-219

Sealed:8/12/2020

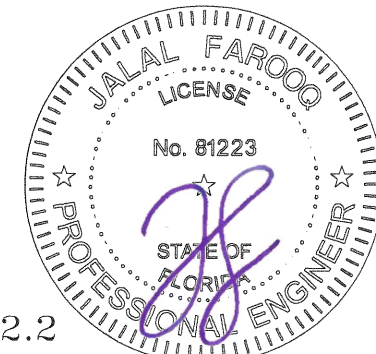

FL #20352.2

af c
AL-FAROOQ CORPORATION
ENGINEERS & PRODUCT DEVELOPMENT
9360 SUNSET DRIVE, SUITE 220 (C.A.N. 3538)
MIAMI, FLORIDA 33173
TEL. (305) 264-8100 FAX. (305) 262-8978
COMP-ANL\W16-21 MG

MG-200 ALUM SINGLE HUNG WINDOW (S.M.I.)
MR-GLASS DOORS & WINDOWS MANUFACTURING, LLC
8051 N.W. 79th Place
Medley, FL. 33166
Tel. (305) 764-3963 Fax. (305) 470-8285

revisions:	no.	date	by	description

date: 04-15-16	scale: -	dr. by: TARIQ	chk. by:
----------------	----------	---------------	----------

drawing no.
W16-21
sheet 2 of 7

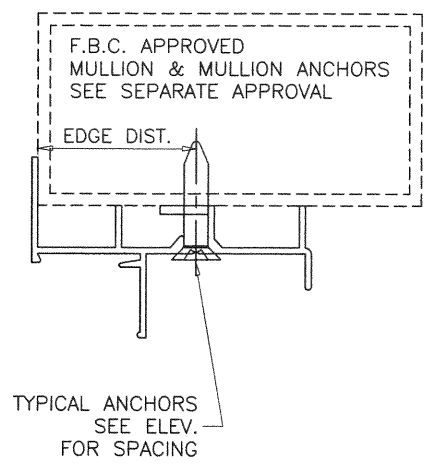
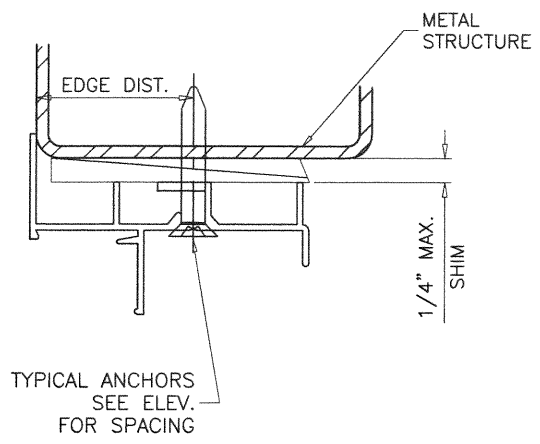
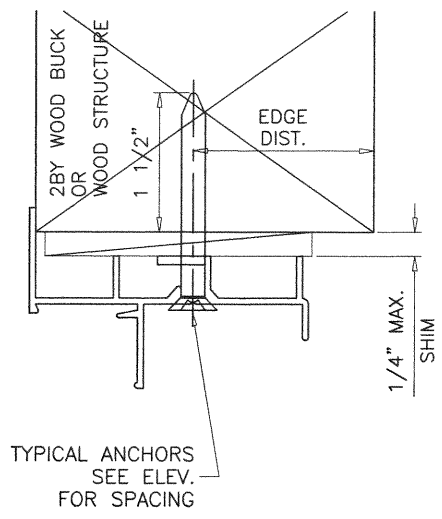
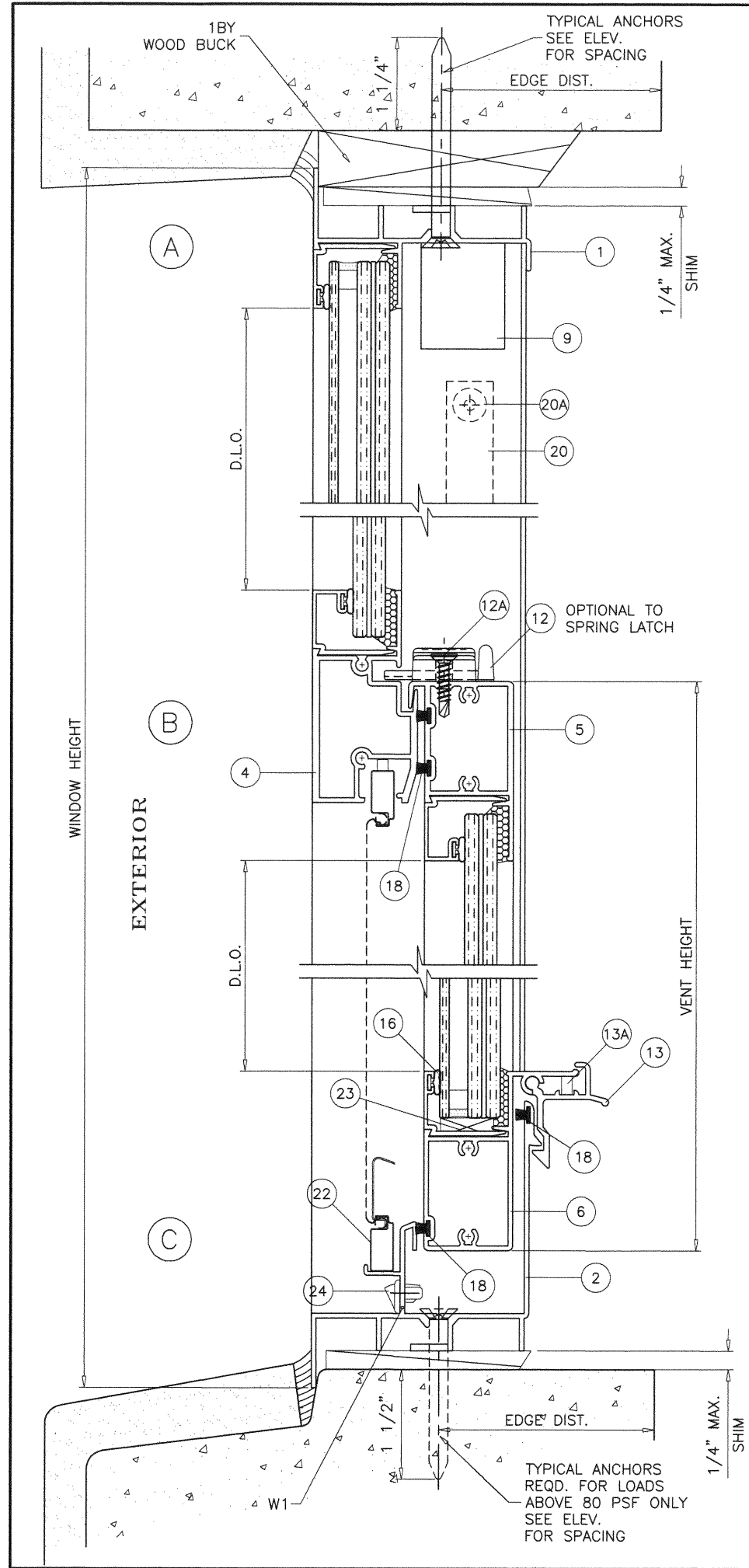

WOOD BUCKS AND METAL STRUCTURE NOT BY MR-GLASS MUST SUSTAIN LOADS IMPOSED BY GLAZING SYSTEM AND TRANSFER THEM TO THE BUILDING STRUCTURE.

WEEPHOLES:

W1 = 1-1/2" X 5/16" WEEPHOLES AT 5-1/2" FROM EACH END

TYPICAL ANCHORS: SEE ELEV. FOR SPACING
 1/4" DIA. ULTRACON+ BY 'DEWALT' (Fu=164 KSI, Fy=148 KSI)
 INTO 2BY WOOD BUCKS OR WOOD STRUCTURES
 1-1/2" MIN. PENETRATION INTO WOOD (HEAD/SILL/JAMBS)
 THRU 1BY BUCKS INTO CONC. OR BLOCKS
 1-1/4" MIN. EMBED INTO CONCRETE (HEAD/SILL/JAMBS)
 1-1/4" MIN. EMBED INTO BLOCKS (JAMBS)
 DIRECTLY INTO CONCRETE OR BLOCKS
 1-1/2" MIN. EMBED INTO CONCRETE (HEAD/SILL/JAMBS)
 1-1/4" MIN. EMBED INTO BLOCKS (JAMBS)

#14 SMS OR SELF-DRILLING SCREWS (GRADE 2 CRS)
 INTO F.B.C. APPROVED MULLIONS
 OR
 INTO METAL STRUCTURES (HEAD/SILL/JAMBS)
 (3) THREADS MIN. TO EXTEND BEYOND METAL THICKNESS
 ALUMINUM: 1/8" THK. MIN. (6063-T5 MIN.)
 STEEL: 1/8" THK. MIN. (Fy = 36 KSI MIN.)
 (STEEL IN CONTACT WITH ALUMINUM TO BE PLATED OR PAINTED)

CRITICAL EDGE DISTANCE
 INTO CONCRETE AND BLOCKS = 2-1/2" MIN.
 INTO WOOD STRUCTURE = 1" MIN.
 INTO METAL STRUCTURE = 3/4" MIN.

WOOD AT HEAD, SILL OR JAMBS SG = 0.55 MIN.
 CONCRETE AT HEAD, SILL OR JAMBS f'c = 3000 PSI MIN.
 C-90 HOLLOW/FILLED BLOCK AT JAMBS f'm = 2000 PSI MIN.

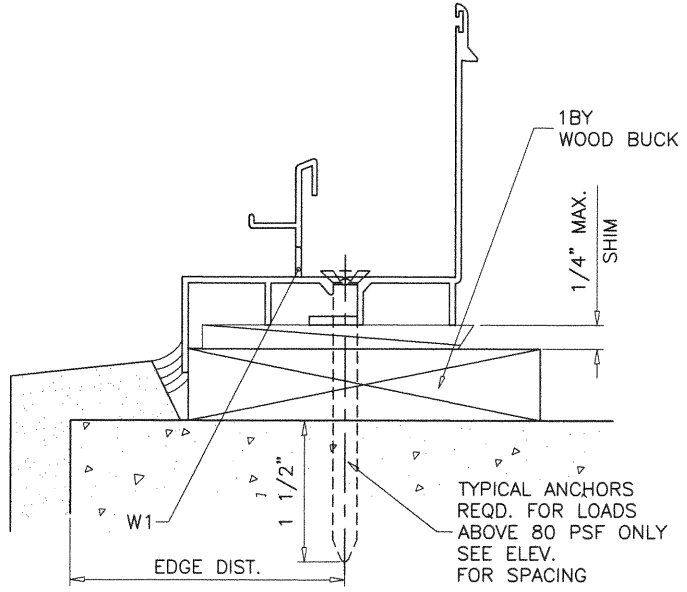

Sealed:8/12/2020

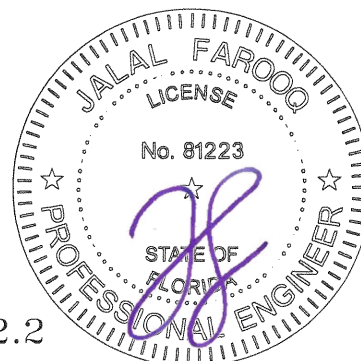

FL #20352.2

af c
AL-FAROOQ CORPORATION
 ENGINEERS & PRODUCT DEVELOPMENT
 9360 SUNSET DRIVE, SUITE 220
 MIAMI, FLORIDA 33173 (C.A.N. 3538)
 TEL. (305) 264-8100 FAX. (305) 262-6978
 COMP-ANL\W16-21MG

MG-200 ALUM SINGLE HUNG WINDOW (S.M.I.)
 MR-GLASS DOORS & WINDOWS MANUFACTURING, LLC
 8051 N.W. 79th Place
 Medley, FL 33166
 Tel. (305) 764-3963 Fax. (305) 470-8285

no.	date	by	description

date: 04-15-16
 scale: 1/2" = 1"
 dr. by: TARIQ
 chk. by:

drawing no.
W16-21
 sheet 3 of 7

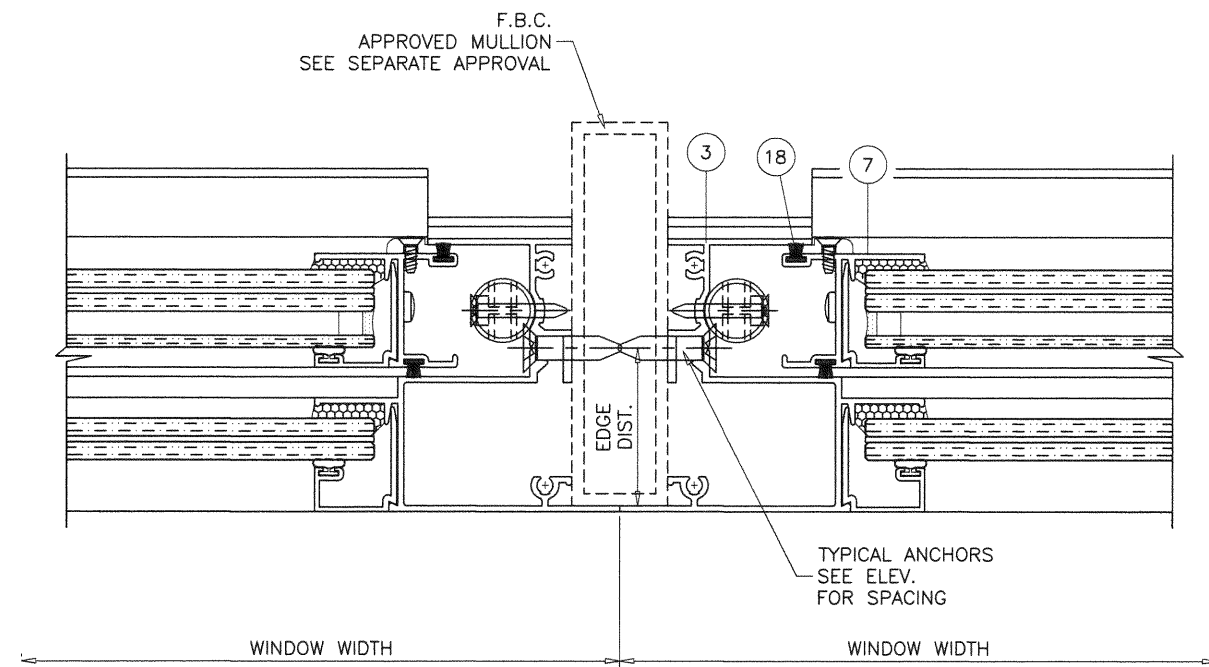
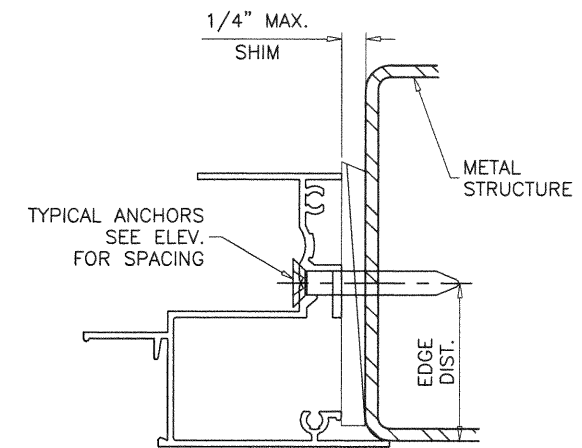
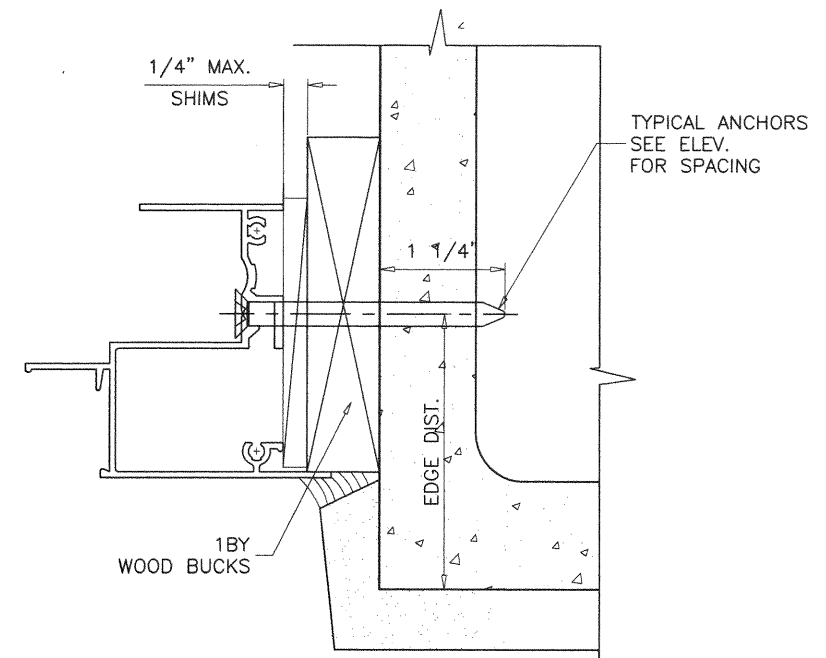
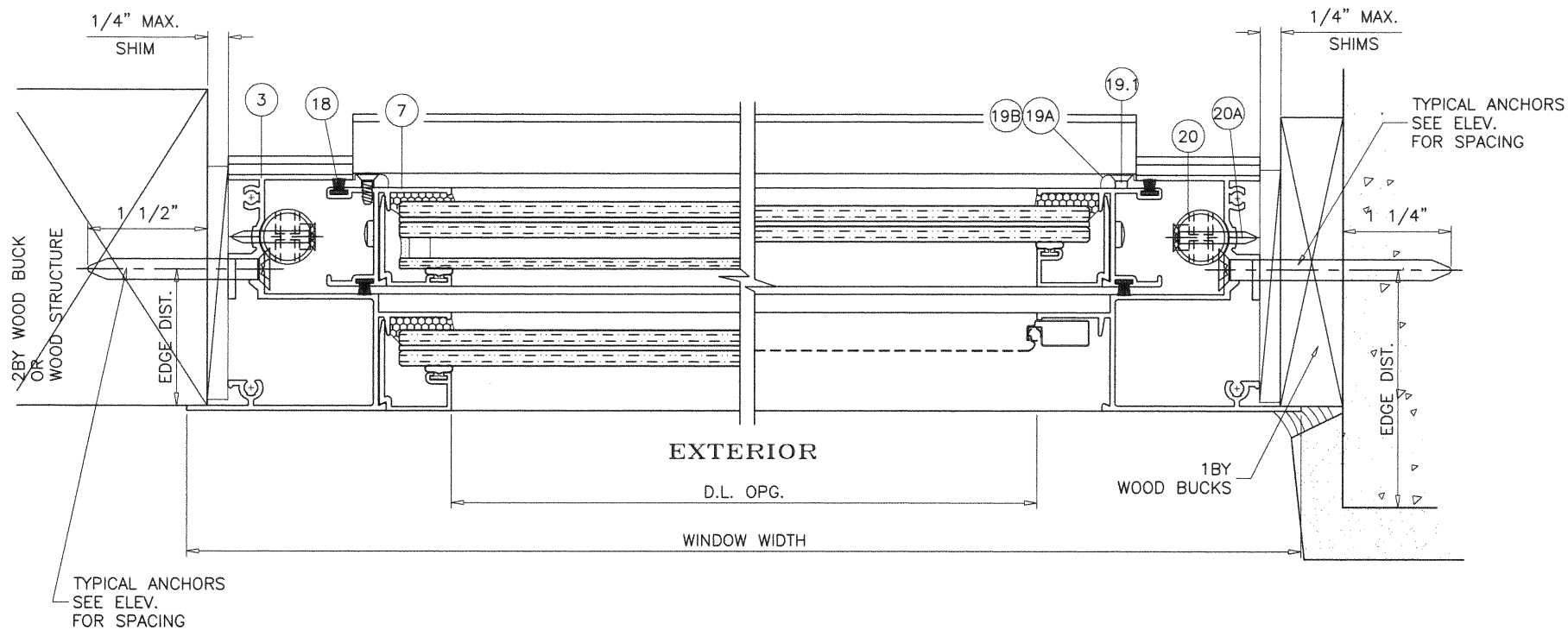

afc

AL-FAROOQ CORPORATION
 ENGINEERS & PRODUCT DEVELOPMENT
 9360 SUNSET DRIVE, SUITE 220
 MIAMI, FLORIDA 33173 (C.A.N. 3538)
 TEL. (305) 264-8100 FAX. (305) 262-8978

COMP-ANL\W16-21MG

MG-200 ALUM SINGLE HUNG WINDOW (S.M.I.)
 MR-GLASS DOORS & WINDOWS MANUFACTURING, LLC
 8051 N.W. 79th Place
 Medley, FL. 33166
 Tel. (305) 764-3963 Fax. (305) 470-8285

no.	date	by	description

date: 04-15-16	scale: 1/2" = 1"	dr. by: TARIQ	chk. by:
----------------	------------------	---------------	----------

drawing no.
W16-21
 sheet 4 of 7

Sealed:8/12/2020

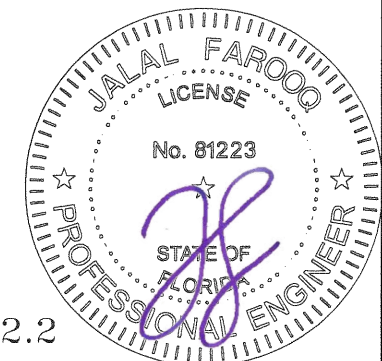

FL #20352.2

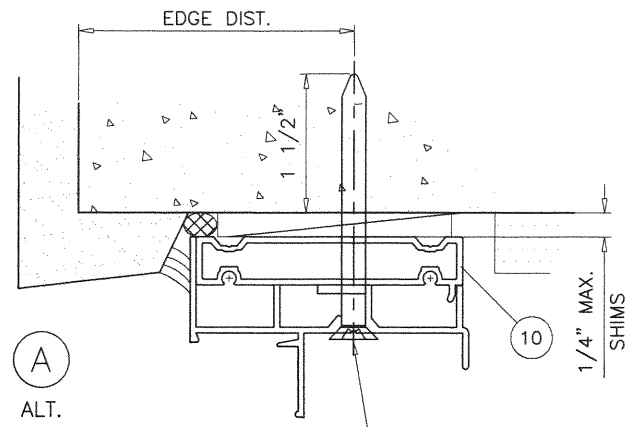

(A)
ALT.

TYPICAL ANCHORS
SEE ELEV.
FOR SPACING

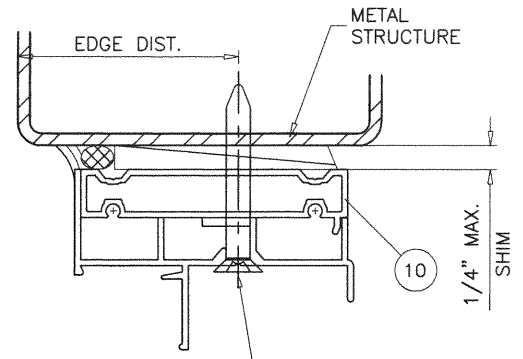

TYPICAL ANCHORS
SEE ELEV.
FOR SPACING

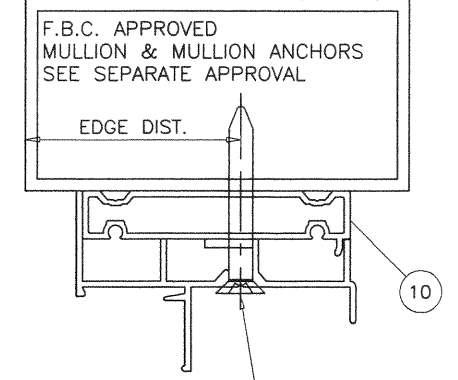

TYPICAL ANCHORS
SEE ELEV.
FOR SPACING

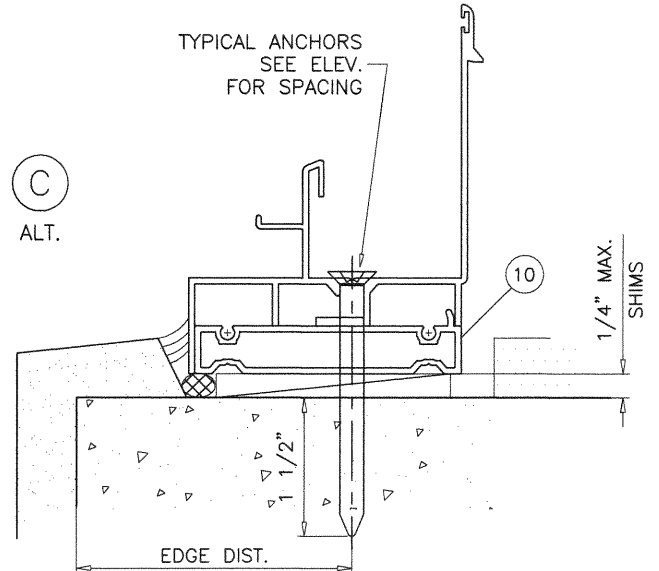

(C)
ALT.

TYPICAL ANCHORS
SEE ELEV.
FOR SPACING

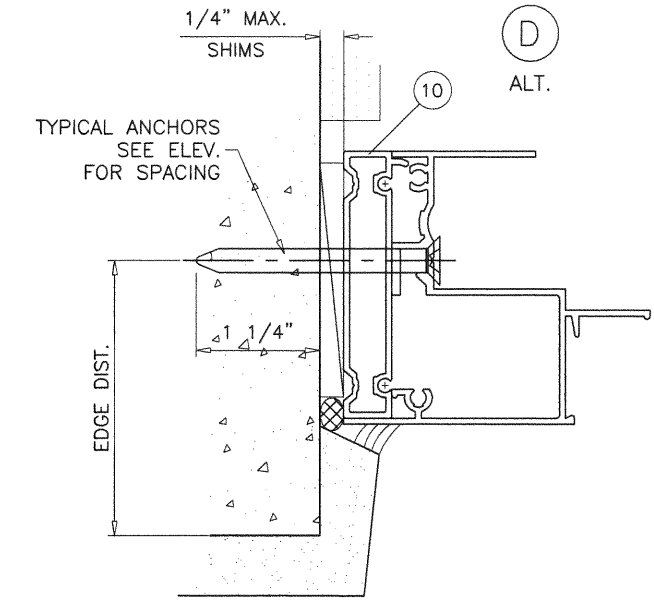

(D)
ALT.

TYPICAL ANCHORS
SEE ELEV.
FOR SPACING

INSTALLATION DETAILS WITH FLUSH FRAME ADAPTER

Sealed: 8/12/2020

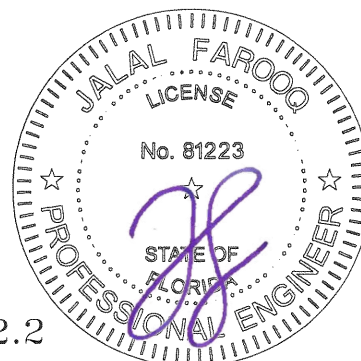

FL #20352.2

afc
AL-FAROOQ CORPORATION
ENGINEERS & PRODUCT DEVELOPMENT
9360 SUNSET DRIVE, SUITE 220 (C.A.N. 3538)
MIAMI, FLORIDA 33173
TEL. (305) 264-8100 FAX. (305) 262-6978
COMP-ANL\W16-21MG

MG-200 ALUM SINGLE HUNG WINDOW (S.M.I.)
MR-GLASS DOORS & WINDOWS MANUFACTURING, LLC
8051 N.W. 79th Place
Medley, FL. 33166
Tel. (305) 764-3963 Fax. (305) 470-8285

no.	date	description

date: 04-15-16
scale: 1/2" = 1"
dr. by: TARIQ
chk. by:

drawing no.
W16-21
sheet 5 of 7

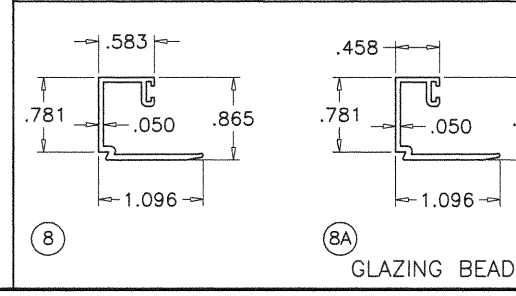
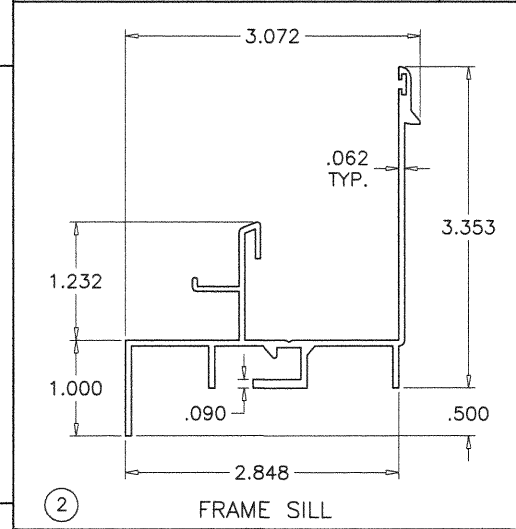
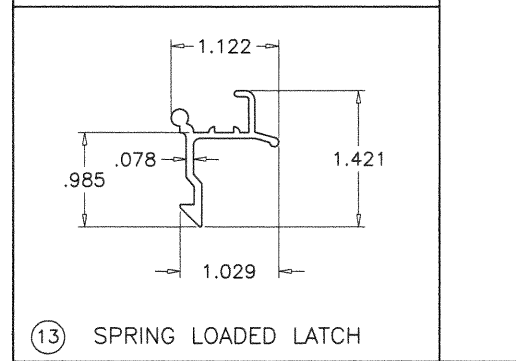
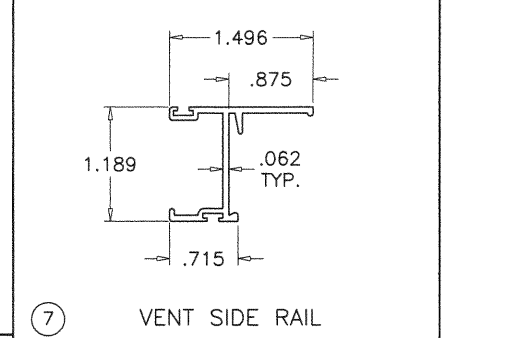
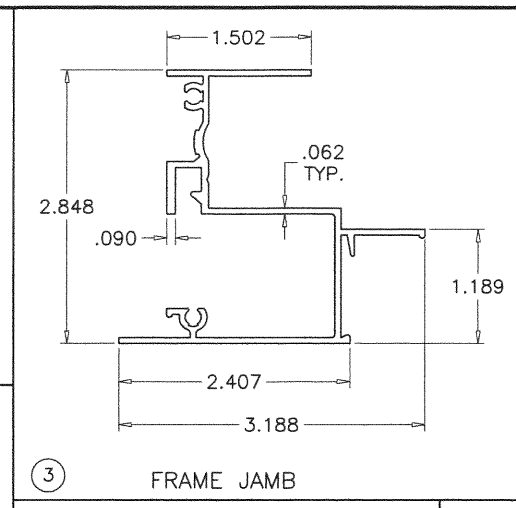
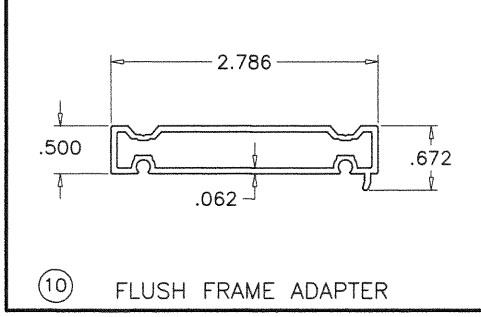
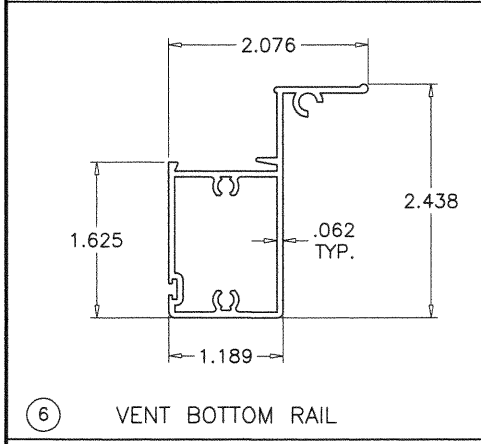
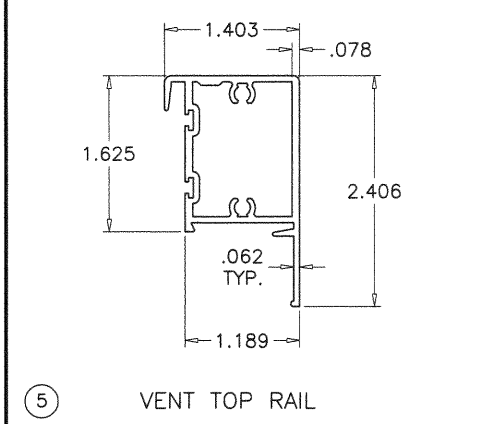
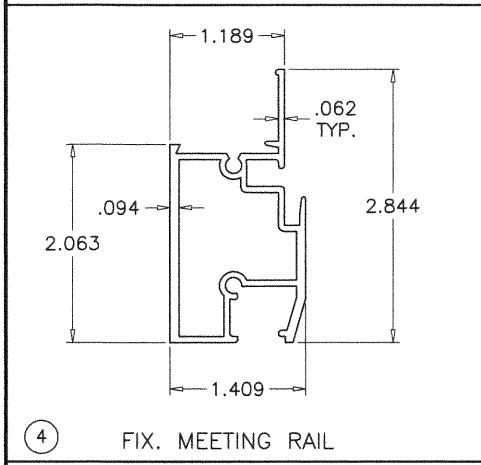
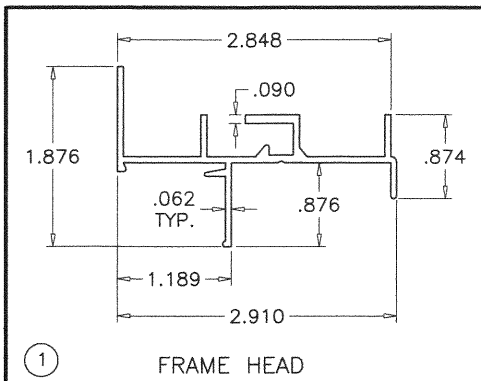

ITEM #	PART #	REQD.	DESCRIPTION	MATERIAL	MANF./SUPPLIER/REMARKS
1	MG201	1	FRAME HEAD	6063-T6	-
2	MG202	1	FRAME SILL	6063-T6	-
3	MG203	2	FRAME JAMB	6063-T6	-
4	MG204	1	FIXED MTG. RAIL	6063-T6	-
5	MG205	1	VENT TOP RAIL	6063-T6	-
6	MG206	1	VENT BOTTOM RAIL	6063-T6	-
7	MG207	2	VENT SIDE RAIL	6063-T6	-
8A	MG209	AS RQD.	GLAZING BEAD (7/16" GLASS)	6063-T6	-
8B	MG210	AS RQD.	GLAZING BEAD (INSUL. LAM. GLASS)	6063-T6	-
9	-	2/VENT	SASH STOP	6063-T6	-
10	MG212	AS REQD.	FLUSH FRAME ADAPTER	6063-T6	-
11	-	-	-	-	-
12	SL203P	2/ VENT	SWEEP LATCH	ZAMAK	SULLIVAN & ASSOC.
12A	#8 X 5/8"	2/ LATCH	LATCH INST. SCREWS	ST. STEEL	OH SMS
13	MG211	2/ VENT	SPRING LOADED LATCH	6063-T6	ALTERNATE TO SWEEP LATCH
13A	-	2/ LATCH	LATCH SPRING	ST. STEEL	-
14	#10 X 1"	AS REQD.	FRAME & VENT ASSEMBLY SCREWS	CRS	PH SMS
16	E202	AS REQD.	GLAZING BEAD BULB	NEOPRENE	ULTRAFAB
18	W73231NK000B	AS REQD.	SIDE RAIL FIN SEAL W/STRIPPING	-	ULTRAFAB
19A	MG221	2/ VENT	VENT BOTTOM GUIDE	CELCON	M&M PLASTICS
19B	MG222	2/ VENT	VENT TOP GUIDE	CELCON	M&M PLASTICS
19.1	#6 X 5/8"	1/ GUIDE	SASH GUIDE INST. SCREW	CRS	FH SMS TYPE B
20	SL-14A-044	2/VENT	ULTRALIFT SPIRAL BALANCE	-	CALDWELL
20A	#10 X 1-1/4"	1/ BALANCE	BALANCE INST. SCREW	-	OH SMS TYPE B
22	-	1	5/16" BOX SCREEN	-	OPTIONAL
23	-	2/ LITE	SETTING BLOCK AT 1/4 POINTS	EPDM	DUROMETER 80±5 SHORE A
24	-	2	HI-FLOW WEEPER	-	PREFERRED ENGINEERING PRODUCTS

af c
AL-FAROOQ CORPORATION
 ENGINEERS & PRODUCT DEVELOPMENT
 9360 SUNSET DRIVE, SUITE 220
 MIAMI, FLORIDA 33173 (C.A.N. 3538)
 TEL. (305) 264-8100 FAX. (305) 262-8978
 COMP-ANL\W16-21MG

MG-200 ALUM SINGLE HUNG WINDOW (S.M.I.)
 MR-GLASS DOORS & WINDOWS MANUFACTURING, LLC
 8051 N.W. 79th Place
 Medley, FL. 33166
 Tel. (305) 764-3963 Fax. (305) 470-8285

revisions:	no.	date	by	description

date: 04-15-16
 scale: 1/2" = 1"
 dr. by: TARIQ
 chk. by:

drawing no.
W16-21
 sheet 6 of 7

Sealed:8/12/2020

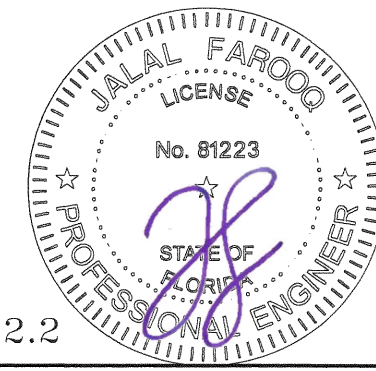

FL #20352.2

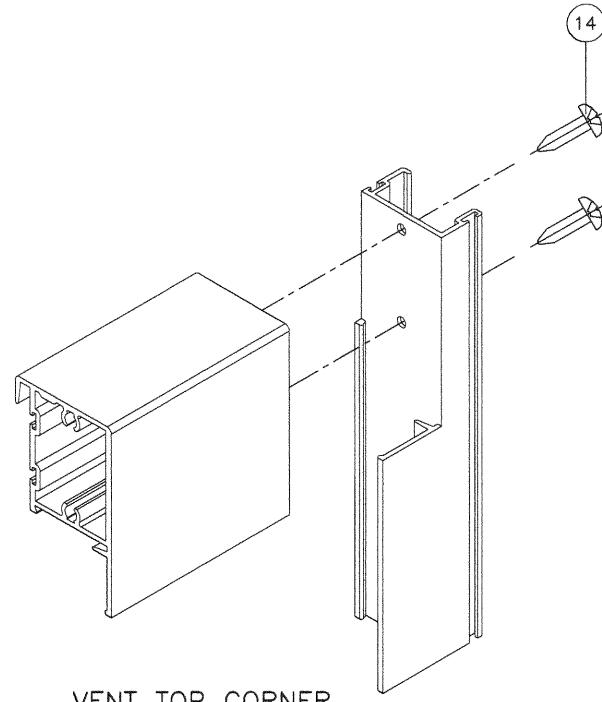

VENT TOP CORNER

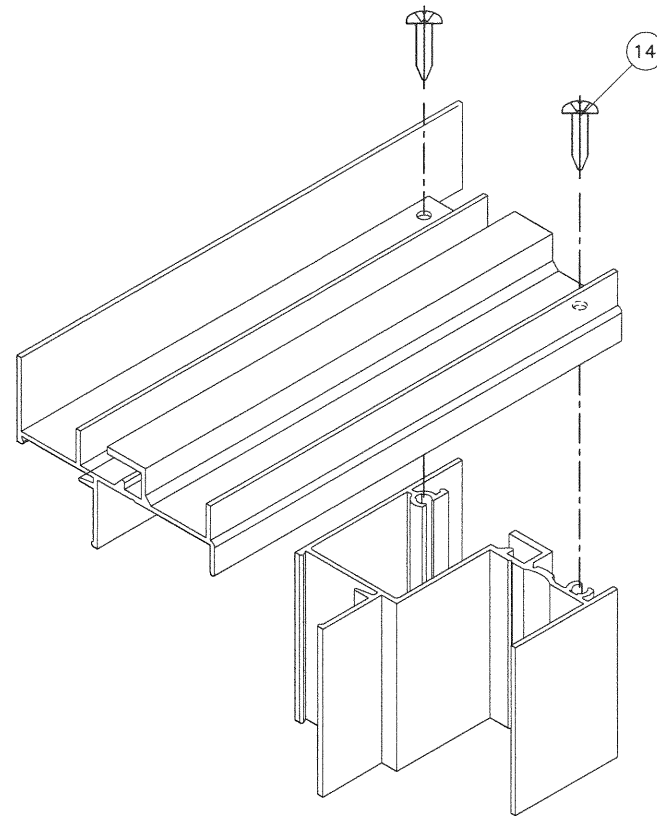

FRAME TOP CORNER

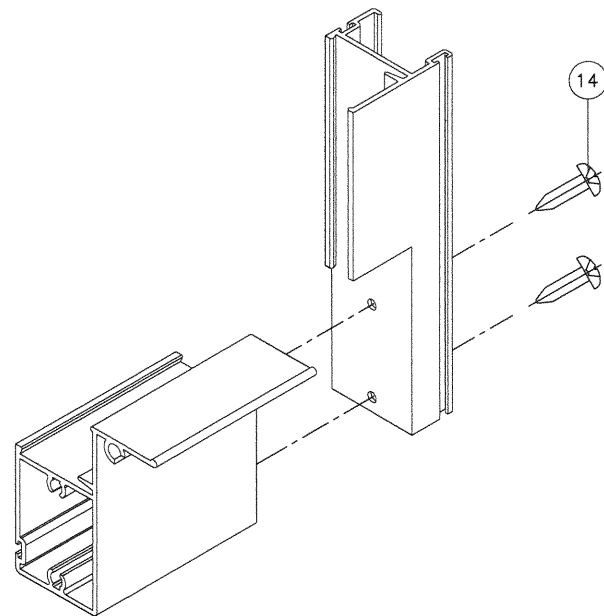

VENT BOTTOM CORNER

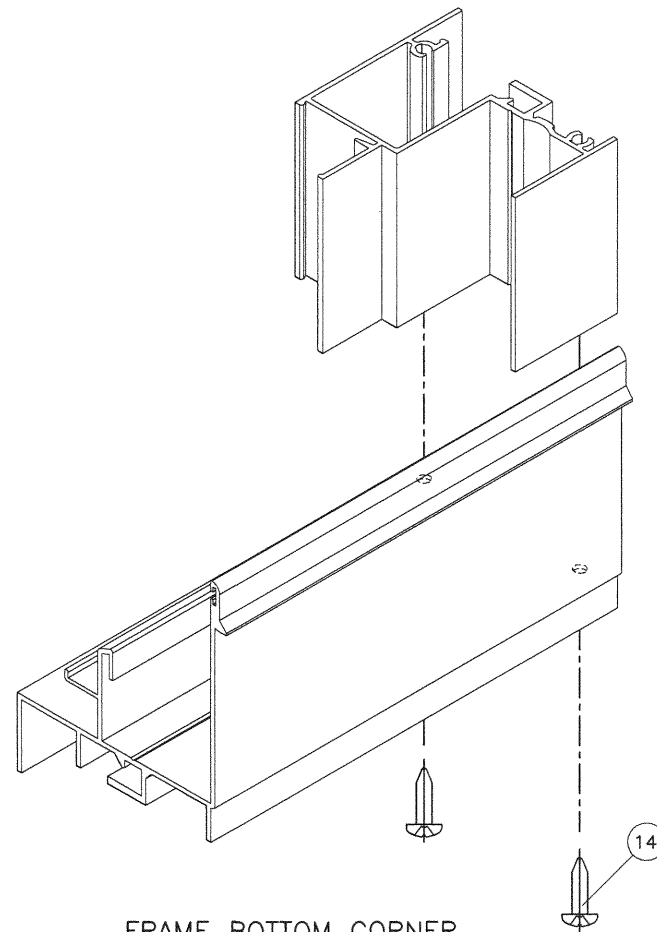

FRAME BOTTOM CORNER

Sealed:8/12/2020

FL #20352.2

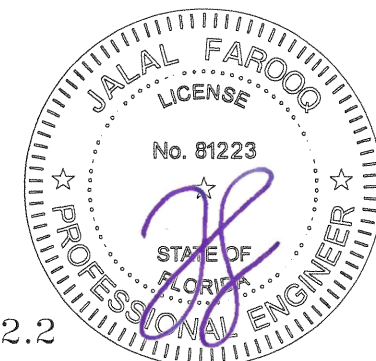

afc
AL-FAROOQ CORPORATION
 ENGINEERS & PRODUCT DEVELOPMENT
 9360 SUNSET DRIVE, SUITE 220 (C.A.N. 3538)
 MIAMI, FLORIDA 33173
 TEL. (305) 264-8100 FAX. (305) 262-6978
 COMP-ANL\W16-21MG

MG-200 ALUM SINGLE HUNG WINDOW (S.M.I.)
 MR-GLASS DOORS & WINDOWS MANUFACTURING, LLC
 8051 N.W. 79th Place
 Medley, FL. 33166
 Tel. (305) 764-3963 Fax. (305) 470-8285

revisions:	
no.	date by description

date: 04-15-16
 scale: 1/2" = 1"
 dr. by: TARIQ
 chk. by:

drawing no.
W16-21
 sheet 7 of 7