

**TYPICAL ELEVATIONS**  
TESTED UNITS

**SERIES MG-300**  
**ALUMINUM HORIZONTAL SLIDING WINDOW**

DESIGN LOAD RATINGS FOR THESE WINDOWS TO BE AS PER CHARTS SHOWN ON SHEET 3.

APPROVAL APPLIES TO SINGLE UNITS OR SIDE BY SIDE COMBINATIONS OF H.R./H.R. OR HORIZ. ROLLING WITH OTHER WINDOW TYPES IN MODULES OF TWO OR MORE WINDOWS USING F.B.C. APPROVED MULLIONS IN BETWEEN. LOWER DESIGN PRESSURE FROM WINDOWS OR MULLION APPROVAL WILL APPLY TO ENTIRE SYSTEM.

THIS PRODUCT HAS BEEN DESIGNED AND TESTED TO COMPLY WITH THE REQUIREMENTS OF THE 2014 (5TH EDITION) FLORIDA BUILDING CODE INCLUDING HIGH VELOCITY HURRICANE ZONE (HVHZ).

WOOD BUCKS BY OTHERS, MUST BE ANCHORED PROPERLY TO TRANSFER LOADS TO THE STRUCTURE.

ANCHORS SHALL BE AS LISTED, SPACED AS SHOWN ON DETAILS, ANCHORS EMBEDMENT TO BASE MATERIAL SHALL BE BEYOND WALL DRESSING OR STUCCO.

ANCHORING OR LOADING CONDITIONS NOT SHOWN IN THESE DETAILS ARE NOT PART OF THIS APPROVAL.

A LOAD DURATION INCREASE IS USED IN DESIGN OF ANCHORS INTO WOOD ONLY.

ALL SHIMS TO BE HIGH IMPACT, NON-METALLIC AND NON-COMPRESSIBLE.

MATERIALS INCLUDING BUT NOT LIMITED TO STEEL/METAL SCREWS, THAT COME INTO CONTACT WITH OTHER DISSIMILAR MATERIALS SHALL MEET THE REQUIREMENTS OF THE 2014 FLORIDA BUILDING CODE.

MANUFACTURER'S LABEL SHALL BE LOCATED ON A READILY VISIBLE LOCATION IN ACCORDANCE WITH SECTION 1710.8.3 OF FLORIDA BUILDING CODE. LABELING TO COMPLY WITH SECTION 1710.8.2.

THESE WINDOWS ARE RATED FOR SMALL MISSILE IMPACT. F.B.C. APPROVED IMPACT RESISTANT SHUTTERS REQUIRED FOR INSTALLATIONS UP TO 30 FT. OF GRADE. SHUTTERS NOT REQD. FOR INSTALLATIONS ABOVE 30 FT. OF GRADE.

- A- THIS PRODUCT EVALUATION DOCUMENT (P.E.D.) PREPARED BY THIS ENGINEER IS GENERIC AND DOES NOT PROVIDE INFORMATION FOR A SITE SPECIFIC PROJECT; i.e. WHERE THE SITE CONDITIONS DEVIATE FROM THE P.E.D.
- B- CONTRACTOR TO BE RESPONSIBLE FOR THE SELECTION, PURCHASE AND INSTALLATION OF THIS PRODUCT BASED ON THIS PRODUCT EVALUATION PROVIDED HE/SHE DOES NOT DEVIATE FROM THE CONDITIONS DETAILED ON THIS DOCUMENT.
- C- THIS PRODUCT EVALUATION DOCUMENT WILL BE CONSIDERED INVALID IF ALTERED BY ANY MEANS.
- D- SITE SPECIFIC PROJECTS SHALL BE PREPARED BY A FLORIDA REGISTERED ENGINEER OR ARCHITECT WHICH WILL BECOME THE ENGINEER OF RECORD (E.O.R.) FOR THE PROJECT AND WHO WILL BE RESPONSIBLE FOR THE PROPER USE OF THE P.E.D. ENGINEER OF RECORD, ACTING AS A DELEGATED ENGINEER TO THE P.E.D. ENGINEER SHALL SUBMIT TO THIS LATTER THE SITE SPECIFIC DRAWINGS FOR REVIEW.
- E- THIS P.E.D. SHALL BEAR THE DATE AND ORIGINAL SEAL AND SIGNATURE OF THE PROFESSIONAL ENGINEER OF RECORD THAT PREPARED IT.

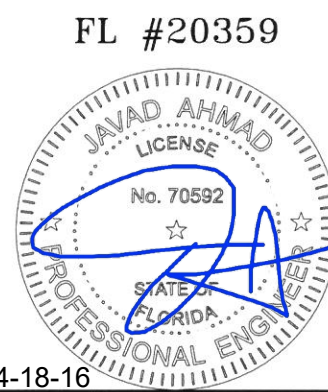

Sealed 4-18-16

**af c**  
**AL-FAROOQ CORPORATION**  
ENGINEERS & PRODUCT DEVELOPMENT  
9360 SUNSET DRIVE, SUITE 220  
MIAMI, FLORIDA 33173 (C.A.N. 3538)  
TEL. (305) 264-8100 FAX. (305) 262-6978  
COMP-ANL W16-28MG

MG-300 ALUM HORIZ. ROLLING WDW. (S.M.I.)  
**MR. GLASS DOORS & WINDOWS INC.**  
8120 N.W. 84 STREET  
MEDLEY, FL. 33166  
TEL. (305) 470-8284 FAX. (305) 470-8285

no.	date	by	description

date: 04-15-16  
scale: 1/2"=1'-0"  
dr. by: TARIQ  
chk. by:  

drawing no.  
**W16-28**  
sheet 1 of 8







DESIGN LOAD CAPACITY - PSF (XO OR OX SIZES)			
FRAME DIMS.		GLASS TYPES 'A' & 'A1'	
WIDTH	HEIGHT	EXT.(+)	INT.(-)
26-1/2"	26"	90.0	140.0
37"		90.0	140.0
53-1/8"		90.0	140.0
63"		90.0	140.0
74"		90.0	140.0
26-1/2"	38-3/8"	90.0	140.0
37"		90.0	140.0
53-1/8"		90.0	140.0
63"		90.0	140.0
74"		90.0	140.0
26-1/2"	50-5/8"	90.0	140.0
37"		90.0	140.0
53-1/8"		90.0	140.0
63"		90.0	140.0
74"		90.0	140.0
26-1/2"	63"	90.0	140.0
37"		90.0	140.0
53-1/8"		90.0	140.0
63"		90.0	140.0
74"		90.0	125.0
24"	24"	90.0	140.0
36"		90.0	140.0
48"		90.0	140.0
60"		90.0	140.0
72"		90.0	140.0
24"	36"	90.0	140.0
36"		90.0	140.0
48"		90.0	140.0
60"		90.0	140.0
72"		90.0	140.0
24"	48"	90.0	140.0
36"		90.0	140.0
48"		90.0	140.0
60"		90.0	140.0
72"		90.0	140.0
24"	60"	90.0	140.0
36"		90.0	140.0
48"		90.0	140.0
60"		90.0	140.0
72"		90.0	136.1

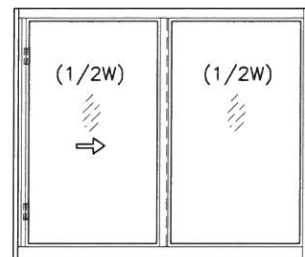

OPERATING VENTS TO BE 1/2 OF THE WDW. WIDTH  
'XO OR OX'

DESIGN LOAD CAPACITY - PSF (XO OR OX SIZES)			
FRAME DIMS.		GLASS TYPES 'A' & 'A1'	
WIDTH	HEIGHT	EXT.(+)	INT.(-)
55-1/2"	26"	90.0	140.0
79-11/16"		90.0	140.0
83-1/4"		90.0	140.0
55-1/2"	38-3/8"	90.0	140.0
79-11/16"		90.0	140.0
83-1/4"		90.0	140.0
55-1/2"	50-5/8"	90.0	140.0
55-1/2"	63"	90.0	140.0
54"	24"	90.0	140.0
63"		90.0	140.0
72"		90.0	140.0
81"	36"	90.0	140.0
54"		90.0	140.0
63"		90.0	140.0
72"	48"	90.0	140.0
81"		90.0	140.0
54"		90.0	140.0
63"	60"	90.0	140.0
72"		90.0	140.0
54"		90.0	140.0

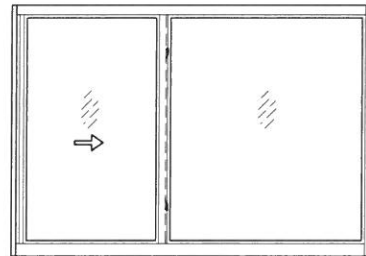

OPERATING VENTS TO BE 1/4 TO 1/3 OF THE WDW. WIDTH  
'XO OR OX'

DESIGN LOAD CAPACITY - PSF (XOX SIZES)			
FRAME DIMS.		GLASS TYPES 'A' & 'A1'	
WIDTH	HEIGHT	EXT.(+)	INT.(-)
74"	26"	90.0	140.0
106-1/4"		90.0	140.0
111"		90.0	140.0
74"	38-3/8"	90.0	140.0
106-1/4"		90.0	140.0
111"		90.0	140.0
74"	50-5/8"	90.0	140.0
106-1/4"		90.0	140.0
111"		90.0	140.0
74"	63"	90.0	140.0
106-1/4"		90.0	129.0
111"		90.0	125.7
108"		90.0	140.0
72"	24"	90.0	140.0
84"		90.0	140.0
96"		90.0	140.0
108"		90.0	140.0
72"	36"	90.0	140.0
84"		90.0	140.0
96"		90.0	140.0
108"		90.0	140.0
72"	48"	90.0	140.0
84"		90.0	140.0
96"		90.0	140.0
108"		90.0	140.0
72"	60"	90.0	140.0
84"		90.0	140.0
96"		90.0	140.0
108"		90.0	136.5

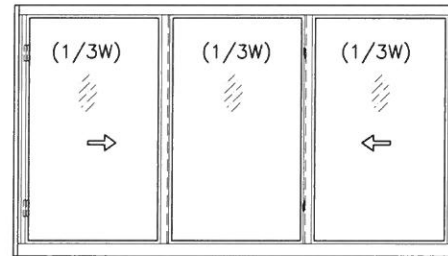

OPERATING VENTS TO BE 1/3 OF THE WDW. WIDTH  
'XOX'

DESIGN LOAD CAPACITY - PSF (XOX SIZES)			
FRAME DIMS.		GLASS TYPES 'A' & 'A1'	
WIDTH	HEIGHT	EXT.(+)	INT.(-)
74"	26"	90.0	140.0
106-1/4"		90.0	140.0
111"		90.0	140.0
74"	38-3/8"	90.0	140.0
106-1/4"		90.0	140.0
111"		90.0	140.0
74"	50-5/8"	90.0	140.0
106-1/4"		90.0	140.0
111"		90.0	140.0
74"	63"	90.0	140.0
106-1/4"		90.0	140.0
111"		90.0	140.0
108"		90.0	140.0
72"	24"	90.0	140.0
84"		90.0	140.0
96"		90.0	140.0
108"		90.0	140.0
72"	36"	90.0	140.0
84"		90.0	140.0
96"		90.0	140.0
108"		90.0	140.0
72"	48"	90.0	140.0
84"		90.0	140.0
96"		90.0	140.0
108"		90.0	140.0
72"	60"	90.0	140.0
84"		90.0	140.0
96"		90.0	140.0
108"		90.0	140.0

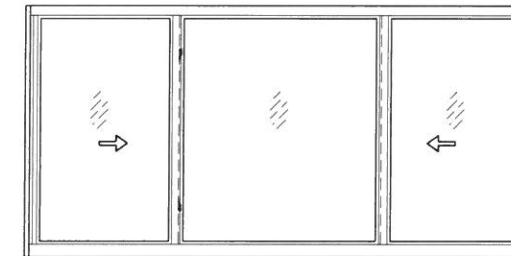

OPERATING VENTS TO BE 1/4 TO 1/3 OF THE WDW. WIDTH  
'XOX'

NOTE:  
GLASS CAPACITIES ON THIS SHEET ARE  
BASED ON ASTM E1300-09 (3 SEC. GUSTS)  
AND FLORIDA BUILDING COMMISSION  
DECLARATORY STATEMENT DCA05-DEC-219

FL #20359

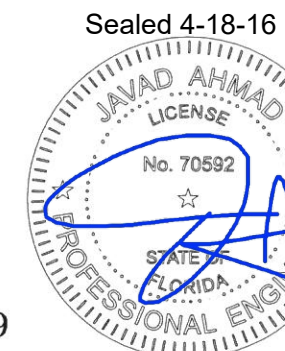

Sealed 4-18-16

**af c**  
**AL-FAROOQ CORPORATION**  
ENGINEERS & PRODUCT DEVELOPMENT  
9360 SUNSET DRIVE, SUITE 220  
MIAMI, FLORIDA 33173 (C.A.N. 3538)  
TEL. (305) 264-8100 FAX. (305) 262-6978  
COMP-ANL\W16-28MG

MG-300 ALUM HORIZ. ROLLING WDW. (S.M.I.)  
**MR. GLASS DOORS & WINDOWS INC.**  
8120 N.W. 84 STREET  
MEDLEY, FL. 33166  
TEL. (305) 470-8284 FAX. (305) 470-8285

no	date	by description

date: 04-15-16  
scale: -  
dr. by: TARIQ  
chk. by:

drawing no.  
**W16-28**  
sheet 3 of 8



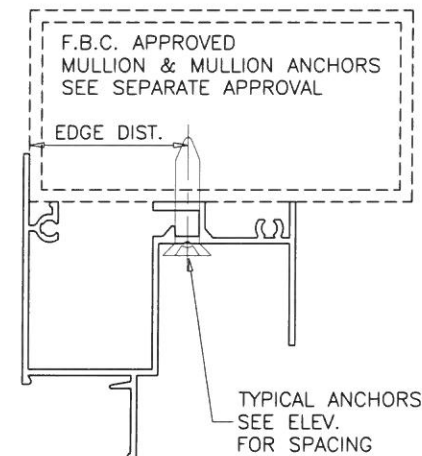
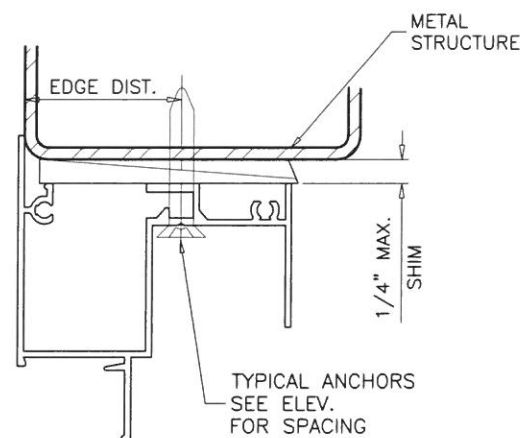
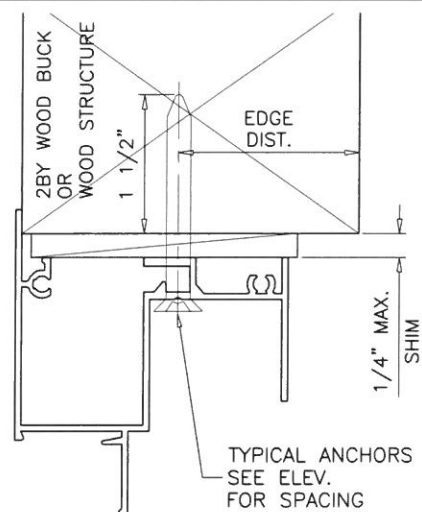
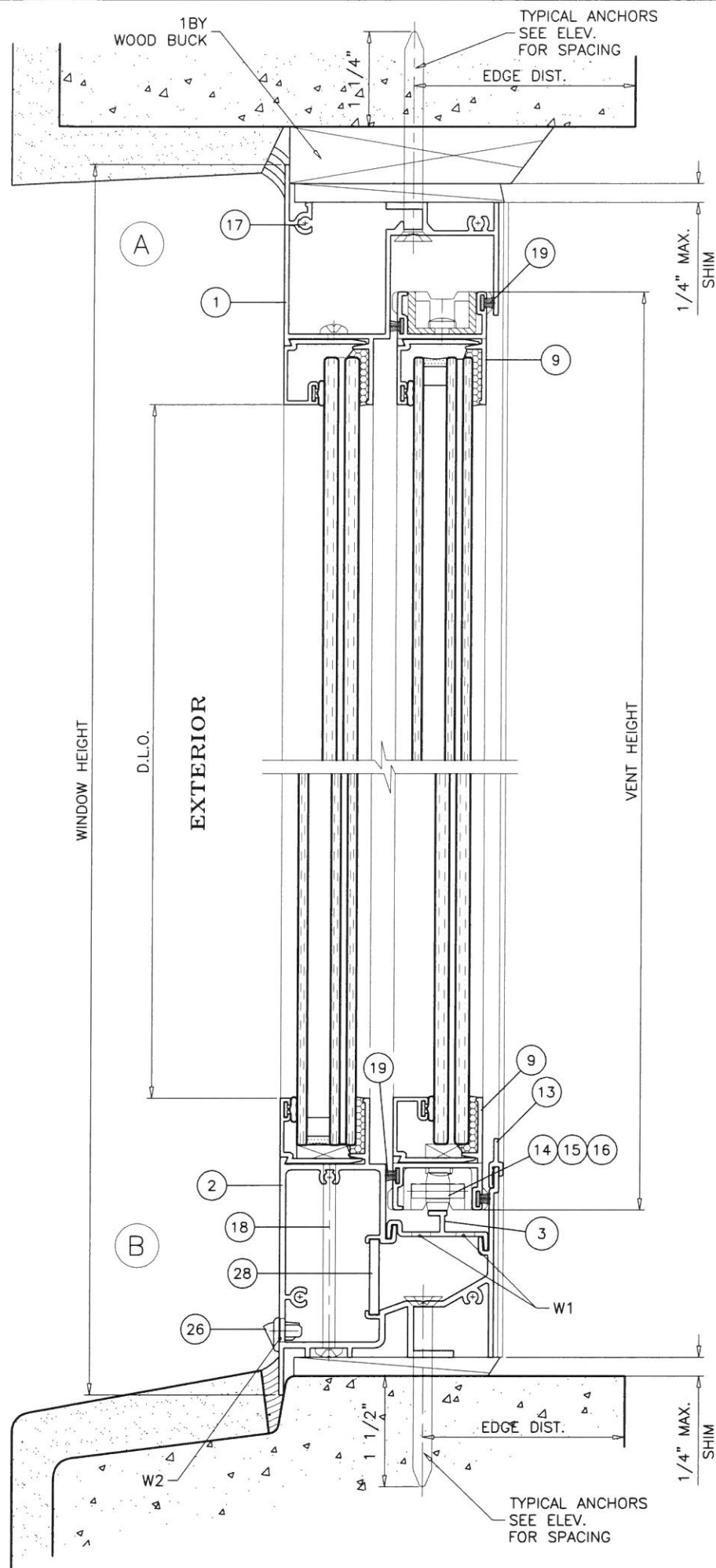

WOOD BUCKS AND METAL STRUCTURE NOT BY MR. GLASS MUST SUSTAIN LOADS IMPOSED BY GLAZING SYSTEM AND TRANSFER THEM TO THE BUILDING STRUCTURE.

**WEEPHOLES:**

W1 = 1" X 1/4" WEEPHOLES AT 2-1/4" FROM EACH END  
 W2 = 1-3/4" X 3/8" WEEPHOLES AT 5-1/2" FROM EACH END WITH PLASTIC BAFFLE

**SEALANTS:**

ALL FRAME CORNERS, FIXED MEETING RAIL TRACK INSERT AT EACH END AND INSTALLATION SCREWS IN SILL SEALED WITH ALUMINUM COLORED SEALANT.

**TYPICAL ANCHORS:** SEE ELEV. FOR SPACING

**1/4" DIA. ULTRACON BY 'ELCO'** (Fu=177 KSI, Fy=155 KSI)  
 INTO 2BY WOOD BUCKS OR WOOD STRUCTURES  
 1-1/2" MIN. PENETRATION INTO WOOD (HEAD/SILL/JAMBS)

THRU 1BY BUCKS INTO CONC. OR MASONRY  
 1-1/4" MIN. EMBED INTO CONCRETE (HEAD/SILL/JAMBS)  
 1-1/4" MIN. EMBED INTO MASONRY (JAMBS)

DIRECTLY INTO CONC. OR MASONRY  
 1-1/2" MIN. EMBED INTO CONCRETE (HEAD/SILL/JAMBS)  
 1-1/4" MIN. EMBED INTO MASONRY (JAMBS)

**#14 SMS OR SELF DRILLING SCREWS** (GRADE 2 CRS)

INTO F.B.C. APPROVED MULLIONS  
 ALUMINUM : 1/8" THK. MIN. (6063-T5 MIN.) (NO SHIM SPACE)

INTO METAL STRUCTURES  
 STEEL : 1/8" THK. MIN. (Fy = 36 KSI MIN.)  
 (STEEL IN CONTACT WITH ALUMINUM TO BE PLATED OR PAINTED)

**TYPICAL EDGE DISTANCE**

INTO CONCRETE AND MASONRY = 2-1/2" MIN.  
 INTO WOOD STRUCTURE = 1" MIN.  
 INTO METAL STRUCTURE = 3/4" MIN.

WOOD AT HEAD, SILL OR JAMBS SG = 0.55 MIN.  
 CONCRETE AT HEAD, SILL OR JAMBS f'c = 3000 PSI MIN.  
 C-90 HOLLOW/FILLED BLOCK AT JAMBS f'm = 2000 PSI MIN.

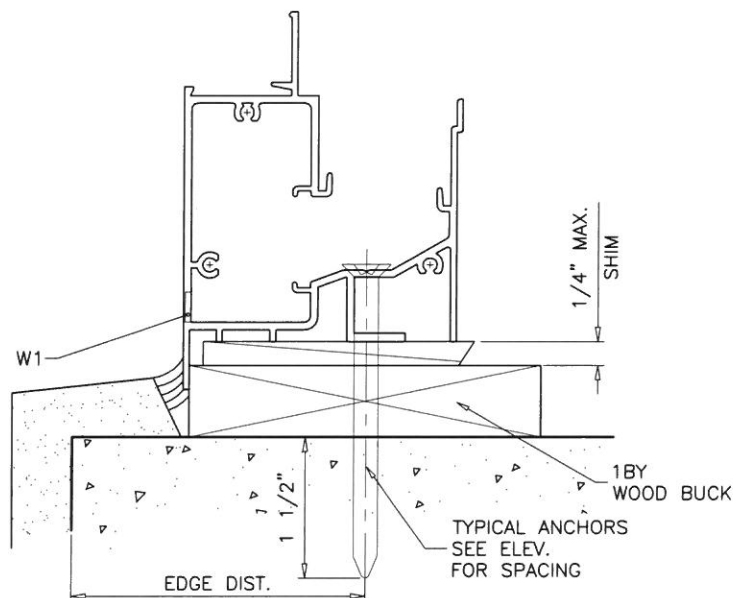

FL #20359

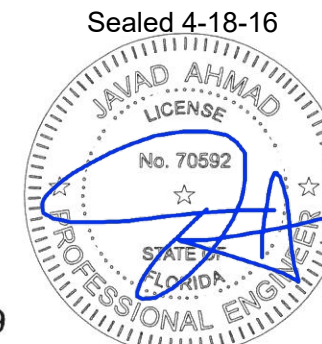

**af c**  
**AL-FAROOQ CORPORATION**  
 ENGINEERS & PRODUCT DEVELOPMENT  
 9360 SUNSET DRIVE, SUITE 220  
 MIAMI, FLORIDA 33173 (C.A.N. 3538)  
 TEL. (305) 264-8100 FAX. (305) 262-6978  
 COMP-ANL\W16-28MG

MG-300 ALUM HORIZ. ROLLING WDW. (S.M.I.)  
**MR. GLASS DOORS & WINDOWS INC.**  
 8120 N.W. 84 STREET  
 MEDLEY, FL. 33166  
 TEL. (305) 470-8284 FAX. (305) 470-8285

revisions:	no	date	by	description

date: 04-15-16  
 scale: 1/2" = 1"  
 dr. by: TARIQ  
 chk. by:

drawing no.  
**W16-28**  
 sheet 4 of 8



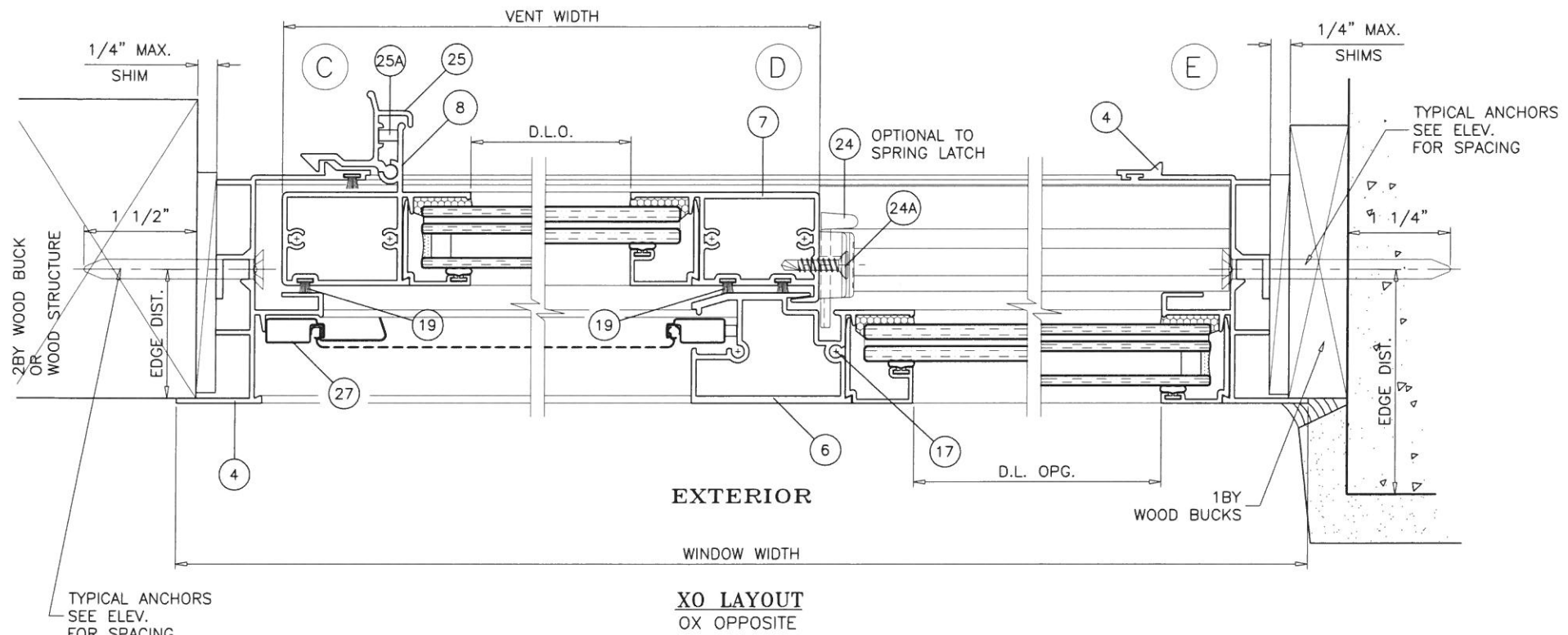

EXTERIOR  
WINDOW WIDTH  
**XO LAYOUT**  
OX OPPOSITE

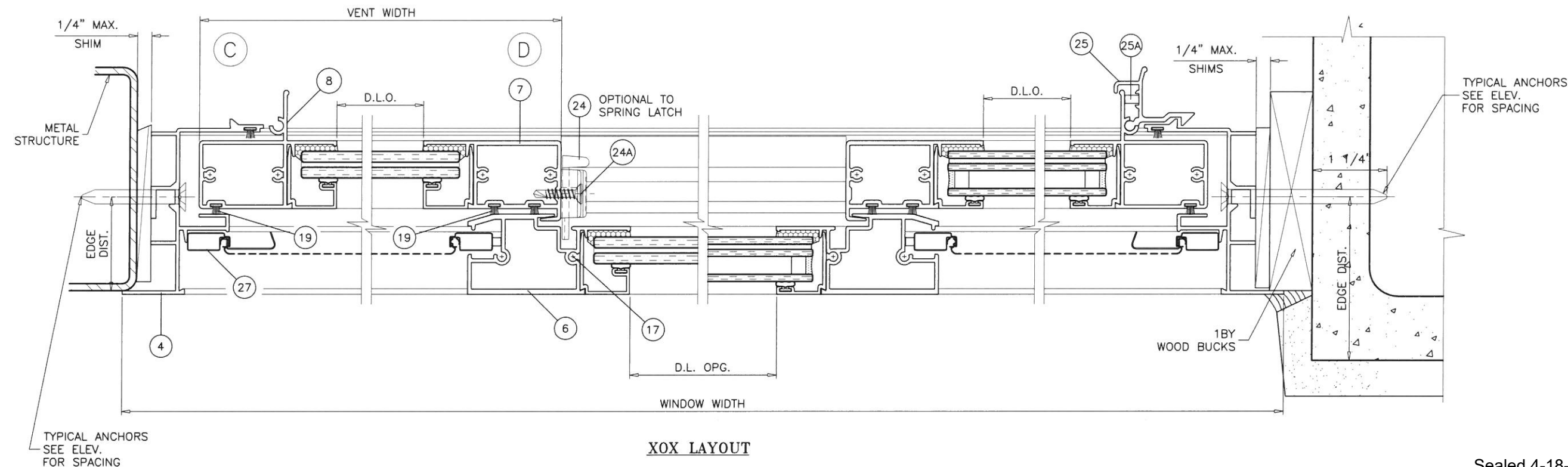

WINDOW WIDTH  
**XOX LAYOUT**

**af c**  
**AL-FAROOQ CORPORATION**  
ENGINEERS & PRODUCT DEVELOPMENT  
9360 SUNSET DRIVE, SUITE 220  
MIAMI, FLORIDA 33173 (C.A.N. 3538)  
TEL. (305) 264-8100 FAX. (305) 262-6978  
COMP-ANL\W16-28MG

MG-300 ALUM HORIZ. ROLLING WDW. (S.M.I.)  
**MR. GLASS DOORS & WINDOWS INC.**  
8120 N.W. 84 STREET  
MEDLEY, FL. 33166  
TEL. (305) 470-8284 FAX. (305) 470-8285

revisions:

no	date	by	description

date: 04-15-16  
scale: 1/2" = 1"  
dr. by: TARIQ  
chk. by:

drawing no.  
**W16-28**  
sheet 5 of 8

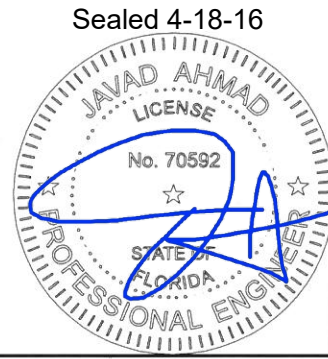

FL #20359

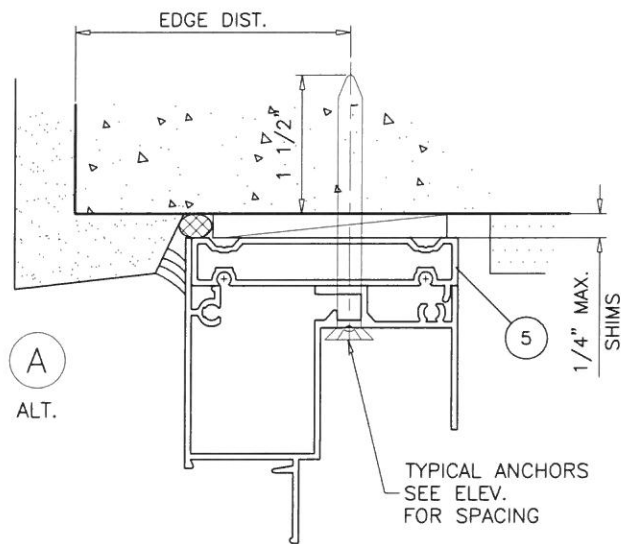

A  
ALT.

TYPICAL ANCHORS  
SEE ELEV.  
FOR SPACING

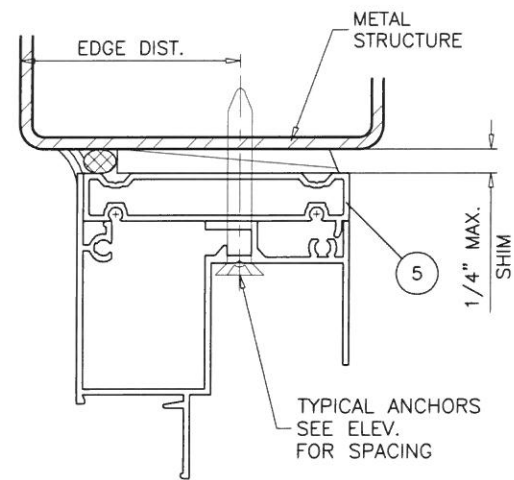

TYPICAL ANCHORS  
SEE ELEV.  
FOR SPACING

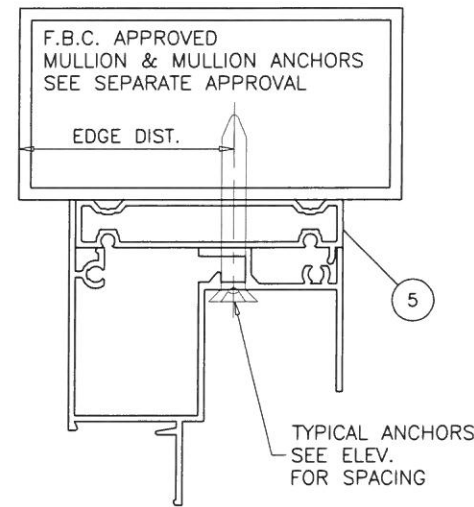

TYPICAL ANCHORS  
SEE ELEV.  
FOR SPACING

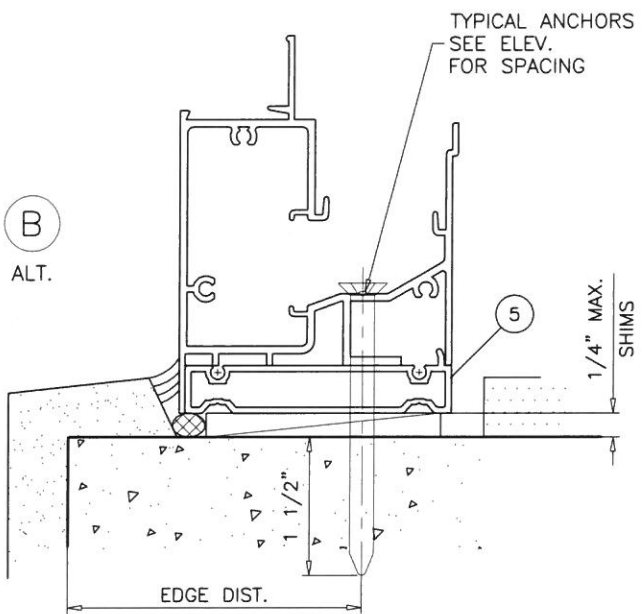

B  
ALT.

TYPICAL ANCHORS  
SEE ELEV.  
FOR SPACING

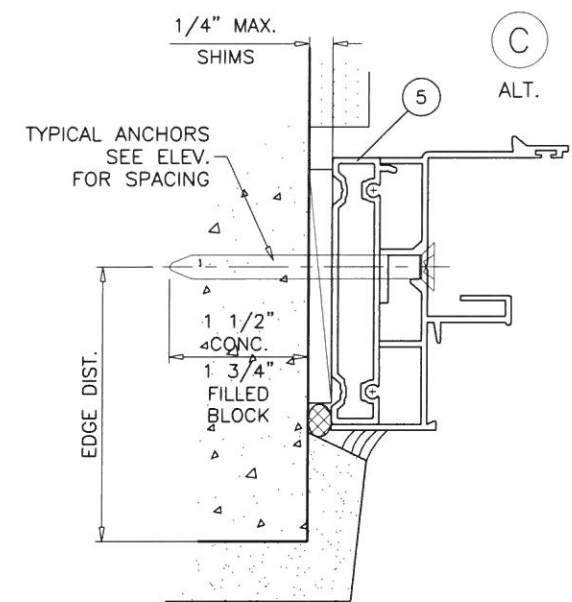

C  
ALT.

TYPICAL ANCHORS  
SEE ELEV.  
FOR SPACING

INSTALLATION DETAILS WITH FLUSH FRAME ADAPTER

FL #20359

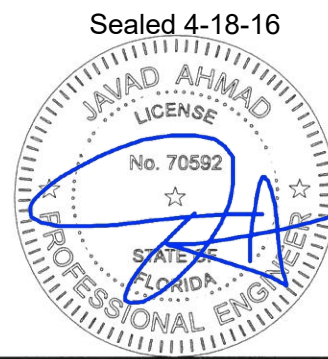

Sealed 4-18-16

**af c**  
**AL-FAROOQ CORPORATION**  
 ENGINEERS & PRODUCT DEVELOPMENT  
 9360 SUNSET DRIVE, SUITE 220  
 MIAMI, FLORIDA 33173 (C.A.N. 3538)  
 TEL. (305) 264-8100 FAX. (305) 262-6978  
 COMP-ANL\W16-28MG

MG-300 ALUM HORIZ. ROLLING WDW. (S.M.I.)  
**MR. GLASS DOORS & WINDOWS INC.**  
 8120 N.W. 84 STREET  
 MEDLEY, FL. 33166  
 TEL. (305) 470-8284 FAX. (305) 470-8285

revisions:	no	date	by	description

date: 04-15-16  
 scale: 1/2" = 1"  
 dr. by: TARIQ  
 chk. by:

drawing no.  
**W16-28**  
 sheet 6 of 8



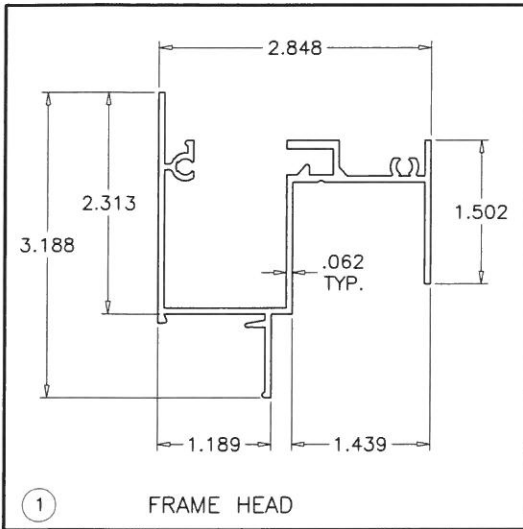

1 FRAME HEAD

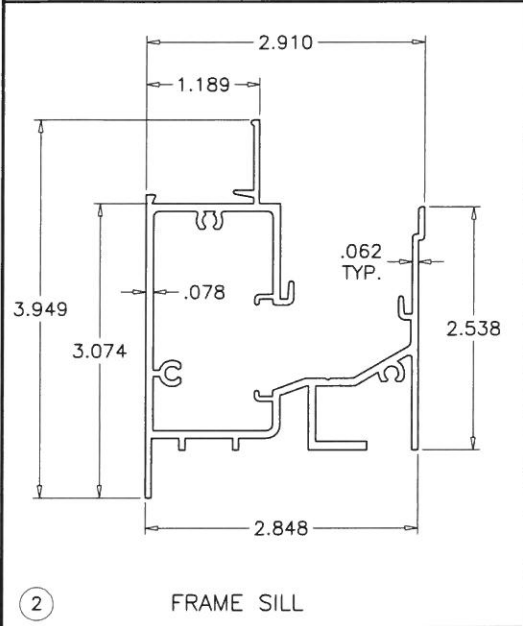

2 FRAME SILL

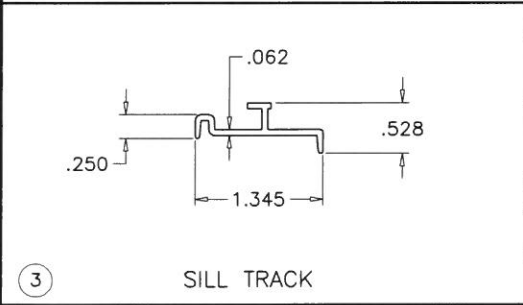

3 SILL TRACK

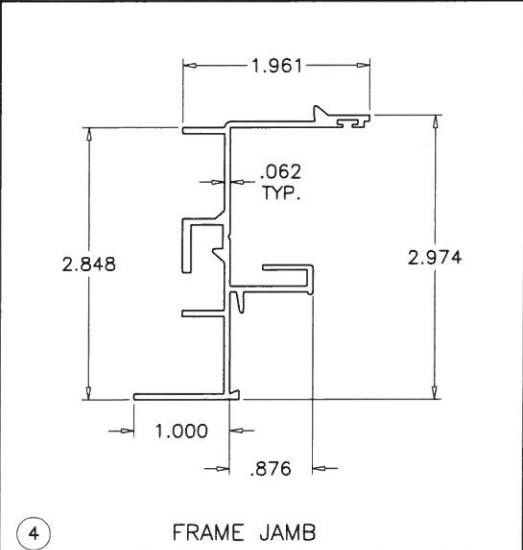

4 FRAME JAMB

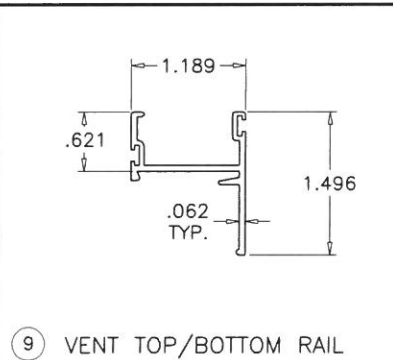

9 VENT TOP/BOTTOM RAIL

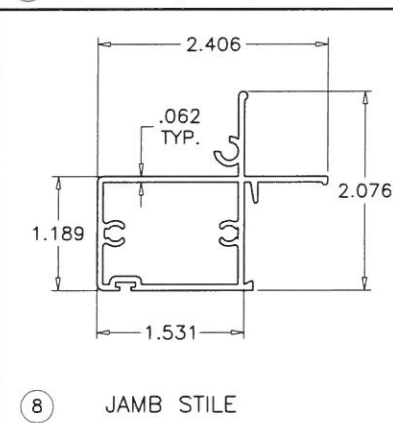

8 JAMB STILE

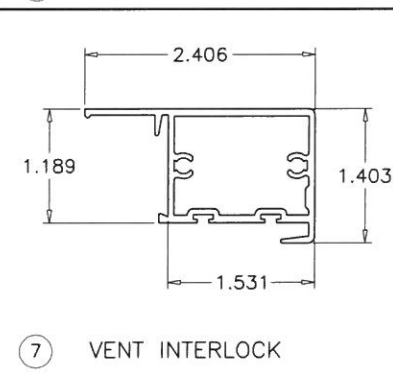

7 VENT INTERLOCK

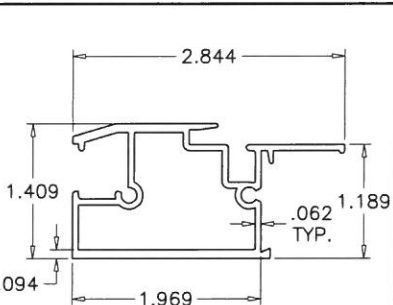

6 FIXED MTG. RAIL

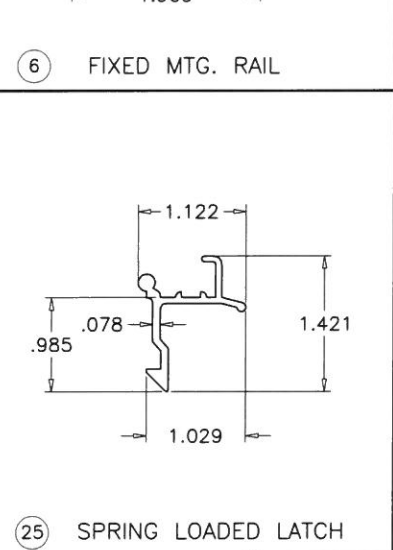

25 SPRING LOADED LATCH

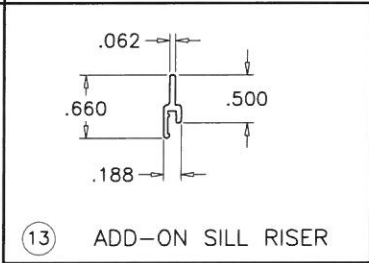

13 ADD-ON SILL RISER

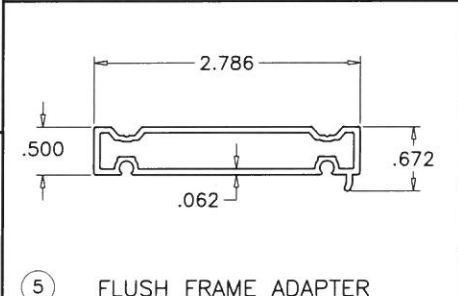

5 FLUSH FRAME ADAPTER

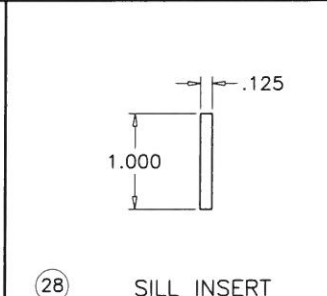

28 SILL INSERT

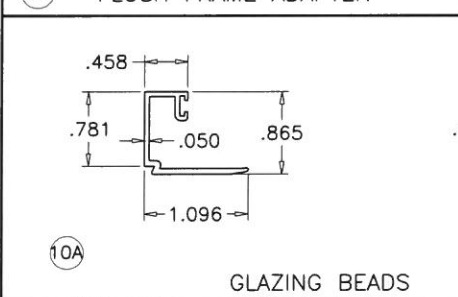

10A

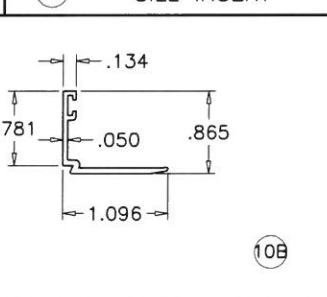

10B

ITEM	PART #	QUANTITY	DESCRIPTION	MATERIAL	MANF./SUPPLIER/REMARKS
1	MG203	1	FRAME HEAD	6063-T6	-
2	MG301	1	FRAME SILL	6063-T6	-
3	MG302	1	SILL TRACK INSERT	6063-T6	-
4	MG303	AS REQD.	FRAME JAMB	6063-T6	-
5	MG212	AS REQD.	FLUSH FRAME ADAPTER	6063-T6	-
6	MG204	1/ VENT	FIXED MTG. RAIL	6063-T6	-
7	MG205	1/ VENT	VENT INTERLOCK	6063-T6	-
8	MG304	1/ VENT	JAMB STILE	6063-T6	-
9	MG207	2/ VENT	TOP AND BOTTOM RAIL	6063-T6	-
10A	MG209	AS REQD.	GLAZING BEAD (7/16" GLASS)	6063-T6	-
10B	MG210	AS REQD.	GLAZING BEAD (INSUL. LAM. GLASS)	6063-T6	-
13	MG305	AS RTEQD.	ADD-ON SILL RISER	6063-T6	-
14	MG321	4/ VENT	ROLLER HOUSING & GUIDE	CELCON	-
15	MG322	2/ VENT	ROLLER	BRASS	-
16	MG323	2/ VENT	ROLLER PIN	ST. STEEL	-
17	#10 X 1"	AS REQD.	FRAME/VENT ASSEMBLY SCREWS	CRS	PH SMS
18	#10 X 3-1/2"	2/ VENT	FIX. RAIL SILL SCREWS (SILL END)	CRS	PH SMS
19	W222322	AS REQD.	FIN SEAL W'STRIPPING	-	ULTRAFAB
22	E202	AS REQD.	GLAZING BEAD BULB	NEOPRENE	ULTRAFAB
24	SL203P	2/ VENT	SWEEP LATCH, AT 10-1/4" FROM EACH END	ZAMAK	SULLIVAN & ASSOC.
24A	#8 X 5/8"	2/ LATCH	LATCH INST. SCREW	ST. STEEL	FH SMS
25	MG211	2/ VENT	SPRING LOADED LATCH	6063-T6	ALTERNATE TO SWEEP LATCH
25A	-	1/ LATCH	LATCH SPRING	ST. STEEL	-
26	-	2/ WDW.	HI-FLOW WEEPER	-	PREFERRED ENGINEERING PRODUCTS
27	-	1/ VENT	5/16" BOX SCREEN	-	OPTIONAL
28	-	AS REQD.	SILL INSERT, 2" LONG	6063-T6	AT MTG. STILE LOCATION
29	-	AS REQD.	SETTING BLOCK AT 1/4 POINTS	EPDM	DUROMETER 80±5 SHORE A

**af c**  
**AL-FAROOQ CORPORATION**  
 ENGINEERS & PRODUCT DEVELOPMENT  
 9360 SUNSET DRIVE, SUITE 220  
 MIAMI, FLORIDA 33173 (C.A.N. 3538)  
 TEL. (305) 264-8100 FAX. (305) 262-6978  
 COMP-ANL\W16-28MG

MG-300 ALUM HORIZ. ROLLING WDW. (S.M.I.)  
**MR. GLASS DOORS & WINDOWS INC.**  
 8120 N.W. 84 STREET  
 MEDLEY, FL. 33166  
 TEL. (305) 470-8284 FAX. (305) 470-8285

revisions:	no	date	by	description

date: 04-15-16  
 scale: 1/2" = 1"  
 dr. by: TARIQ  
 chk. by:  
 drawing no.  
**W16-28**  
 sheet 7 of 8

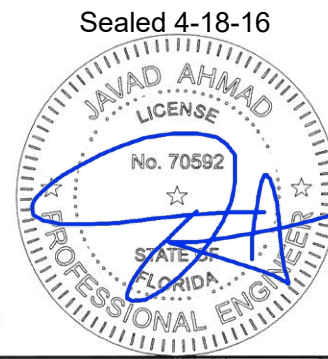

FL #20359

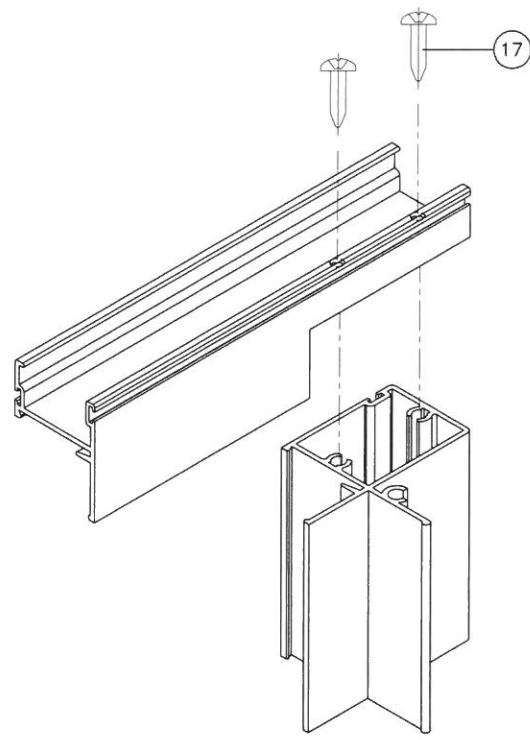

VENT TOP/BOTTOM CORNER

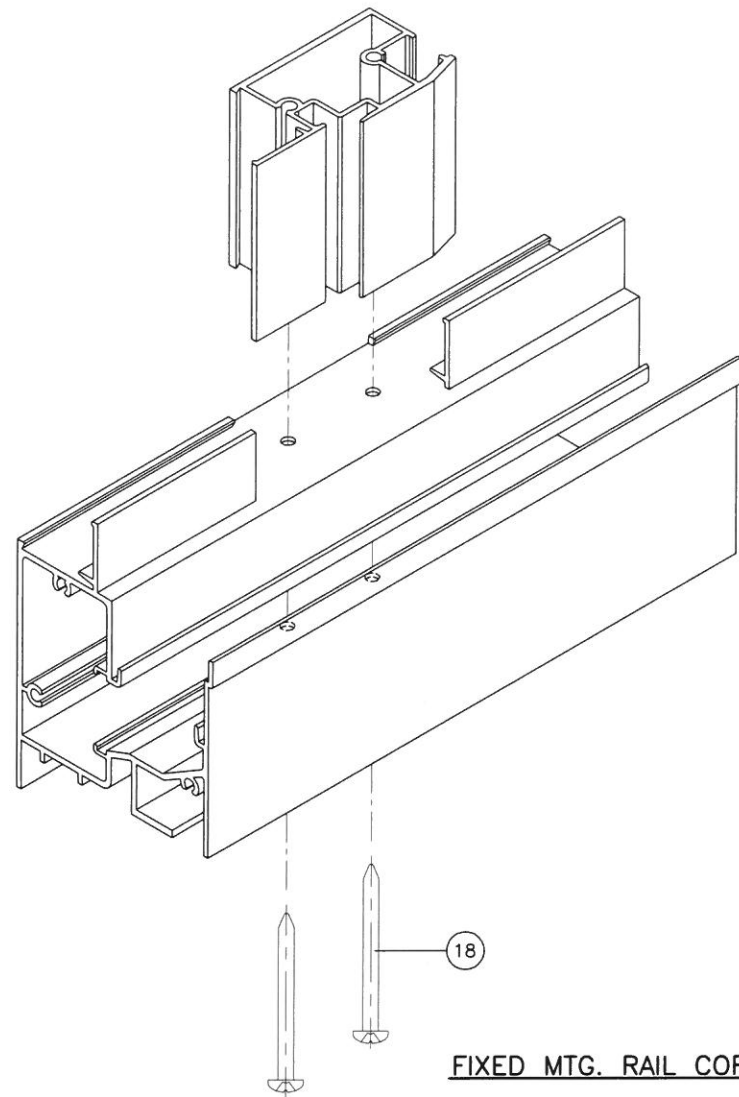

FIXED MTG. RAIL CORNER

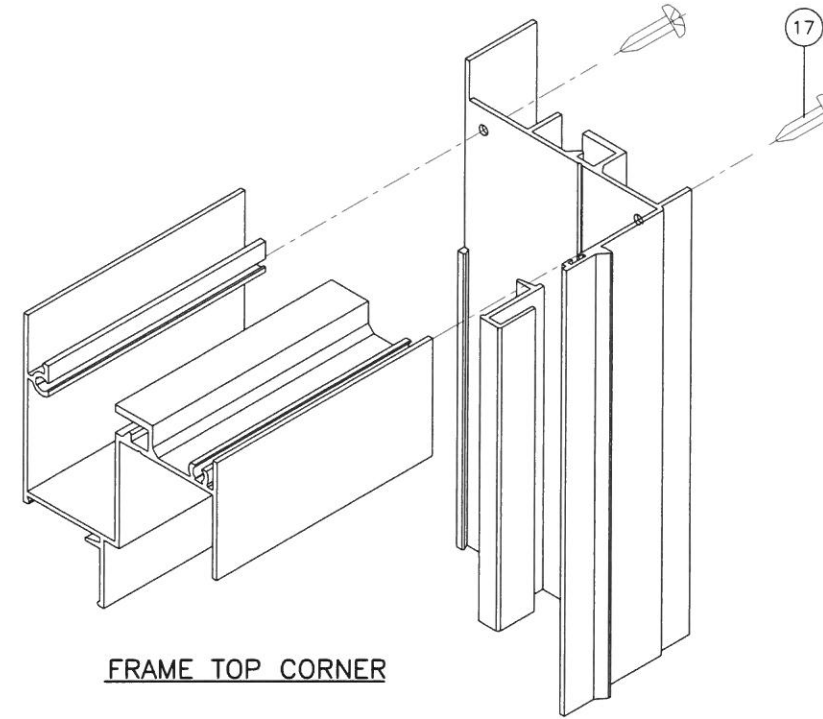

FRAME TOP CORNER

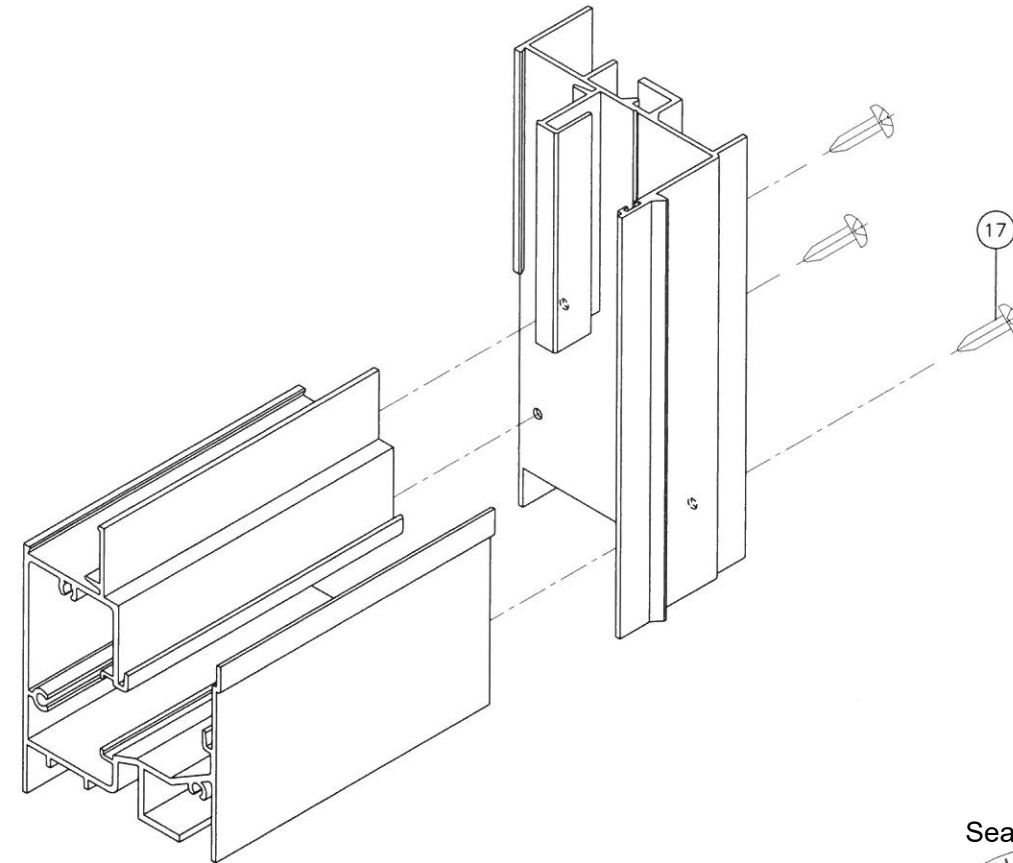

FRAME BOTTOM CORNER

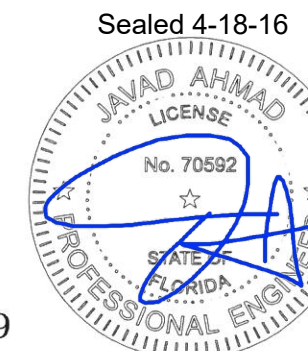

FL #20359

**afc**

**AL-FAROOQ CORPORATION**  
ENGINEERS & PRODUCT DEVELOPMENT  
9360 SUNSET DRIVE, SUITE 220  
MIAMI, FLORIDA 33173 (C.A.N. 3538)  
TEL. (305) 264-8100 FAX. (305) 262-6978  
COMP-ANL\W16-28MG

MG-300 ALUM HORIZ. ROLLING WDW. (S.M.I.)  
**MR. GLASS DOORS & WINDOWS INC.**  
8120 N.W. 84 STREET  
MEDLEY, FL. 33166  
TEL. (305) 470-8284 FAX. (305) 470-8285

revisions:	
no	date

date: 04-15-16  
scale: 1/2" = 1"  
dr. by: TARIQ  
chk. by:

drawing no.  
**W16-28**  
sheet 8 of 8