

Interior Elevation

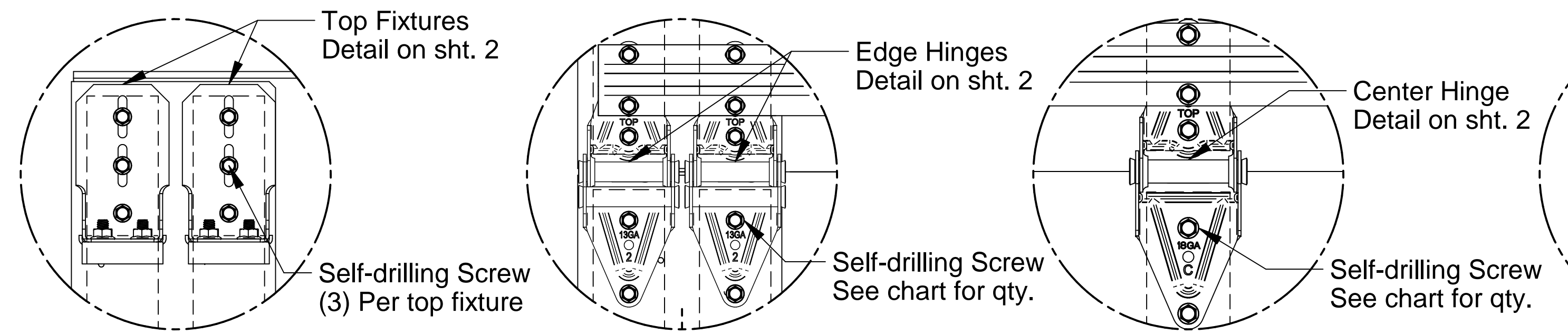

Top Fixture Attachment

Edge Hinge Attachment

Center Hinge Attachment

Corner Bracket Attachment

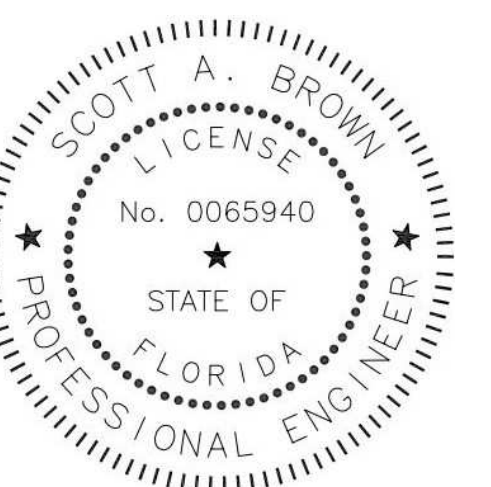

Scott A. Brown, P.E. Lic. No. 65940
Willett, Hofmann & Associates, Inc.
809 E. 2nd Street, Dixon, IL 61021
FBPE CA Lic. No. 35415
Structural Adequacy for Wind Load

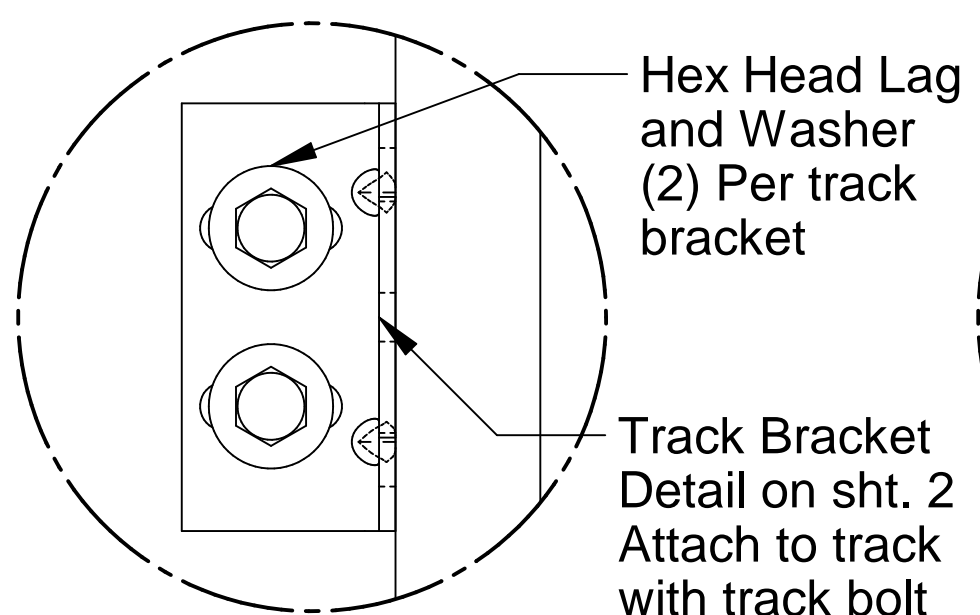

Track Bracket Attachment

Alternate mounting details on sht. 4

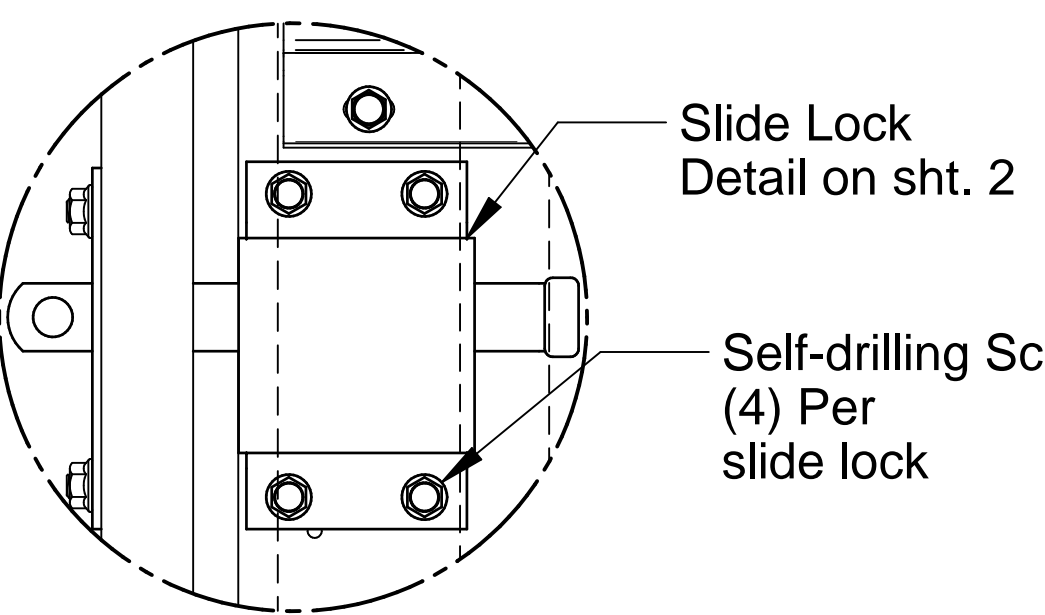

Slide Lock Attachment

Req'd on doors without operators.

Wind loaded sectional doors are designed, tested, and sold by PSF. The AHJ of a given jobsite is responsible for determining the appropriate PSF.

Complies with the Wind Load requirements of the IBC/IRC 2021

Self-drilling Screws Required			
Upper Section	Lower Section	Edge Hinge	Center Hinge
Full-View Aluminum	Raynor EnergyCore	5	5
Full-View Aluminum	Full-View Aluminum	6	6
Raynor EnergyCore	Full-View Aluminum	5	5
Raynor EnergyCore	Raynor EnergyCore	4	4

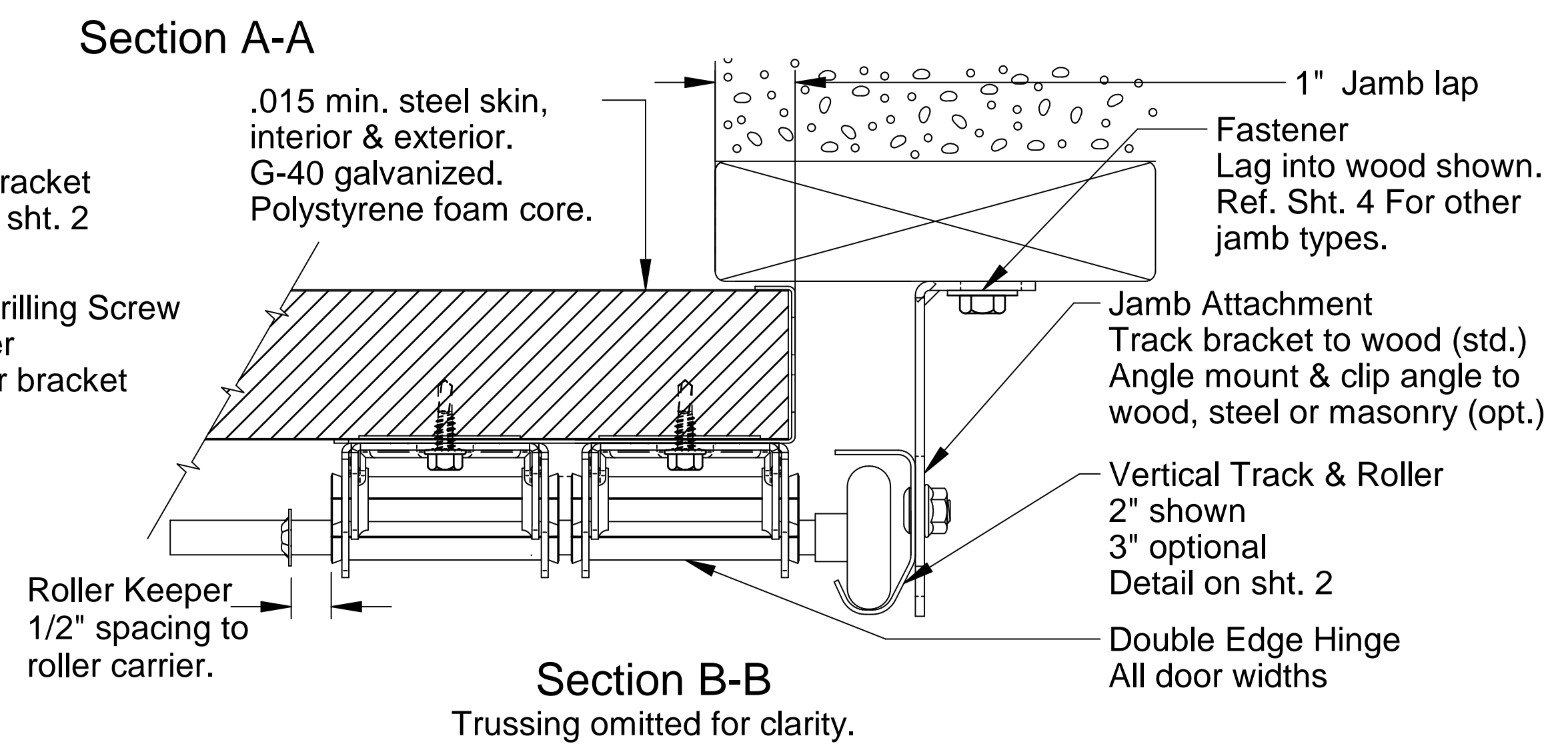

Doors tested per ANSI/DASMA 108 for static air pressure
ANSI/DASMA 115 for impact and cyclic pressure

EC200 / EC224				
Max. Section Width	Max. Opening Width	Stiles	Design Load	
20'-2"	20'-0"	4	26.3	-29.3

FL#20374

Rev.	Description	ECO	Date	ECO: 9063.01
A	New release for production.	9063.01	05/02/24	Date: 05/02/24

Scale: None
Drawn by: J. Poitras
Checked by: R. Frey
Date: 05/02/24

1101 East River Road
Dixon, IL 61021

Title: Spec, Wind Load Raynor EnergyCore

No. P-3410
Sheet 1 of 4
Rev A

Installation Hardware

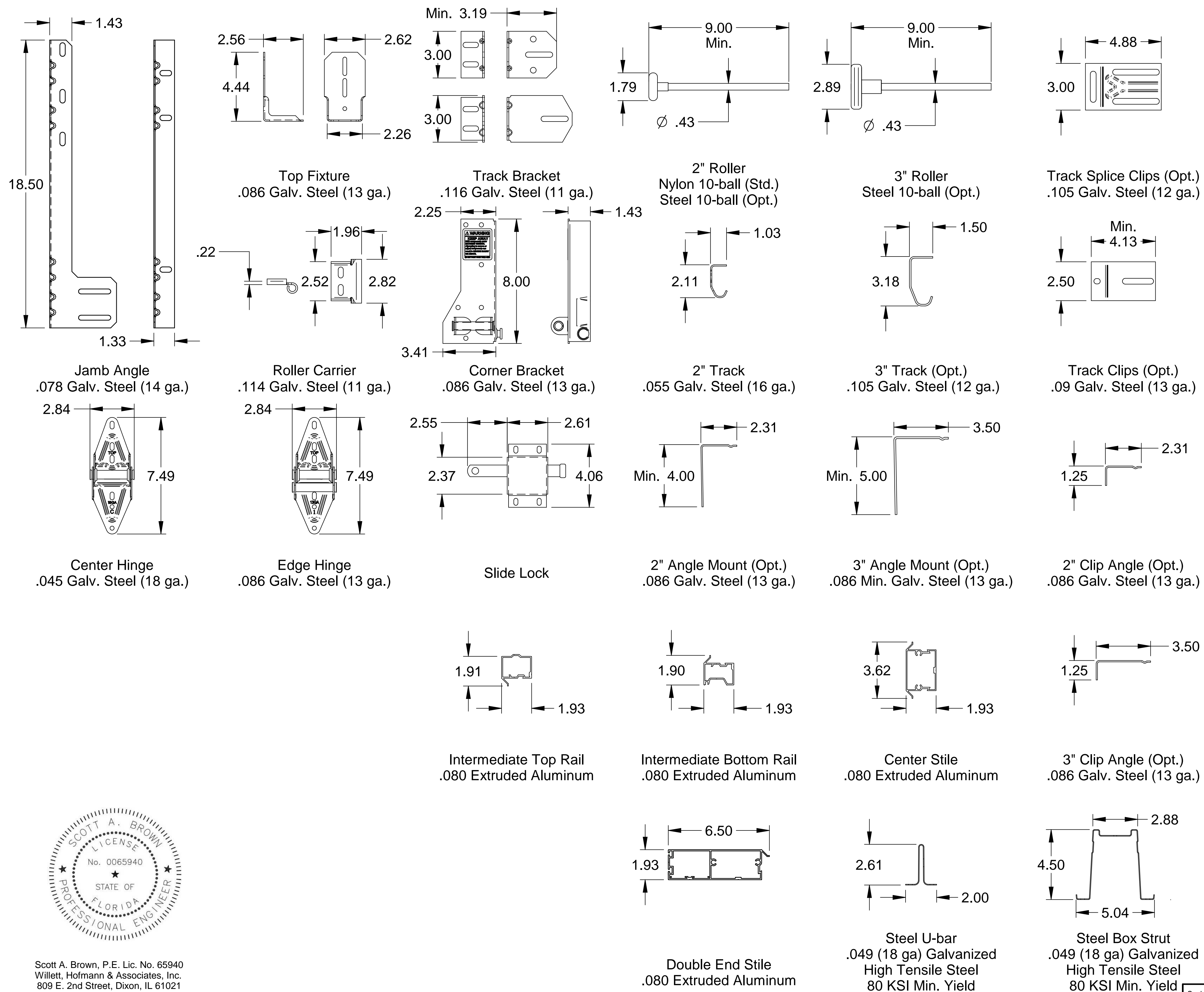

Fasteners & Small Hardware

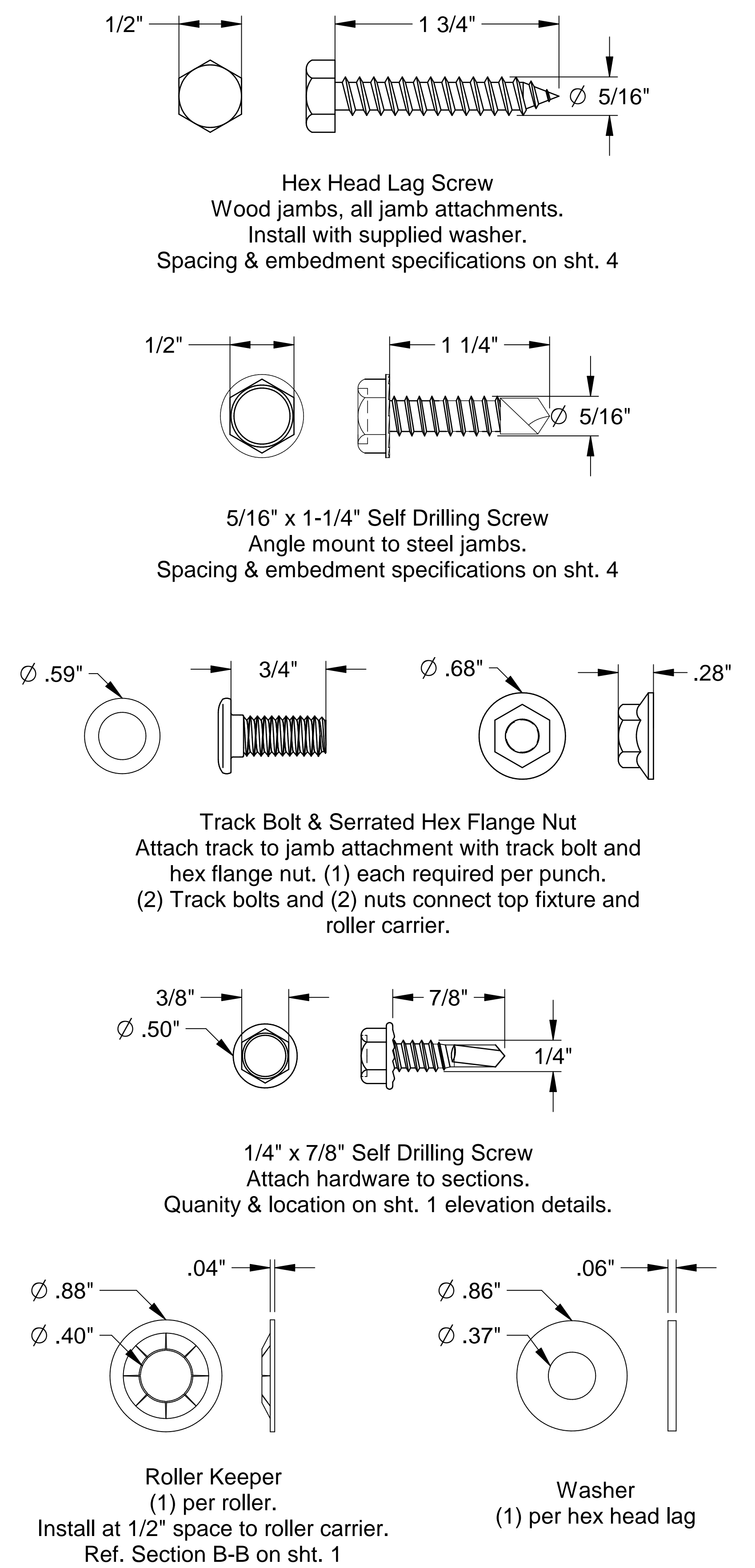

Scott A. Brown, P.E. Lic. No. 65940
Willett, Hofmann & Associates, Inc.
809 E. 2nd Street, Dixon, IL 61021
FBPE CA Lic. No. 35415
Structural Adequacy for Wind Load

Scale: None	 1101 East River Road Dixon, IL 61021	Title: Spec, Wind Load Raynor EnergyCore	
Drawn by: J. Poitras		No. P-3410	Sheet 2
Checked by: R. Frey			Rev A
Date: 05/02/24		ECO: 9063.01	

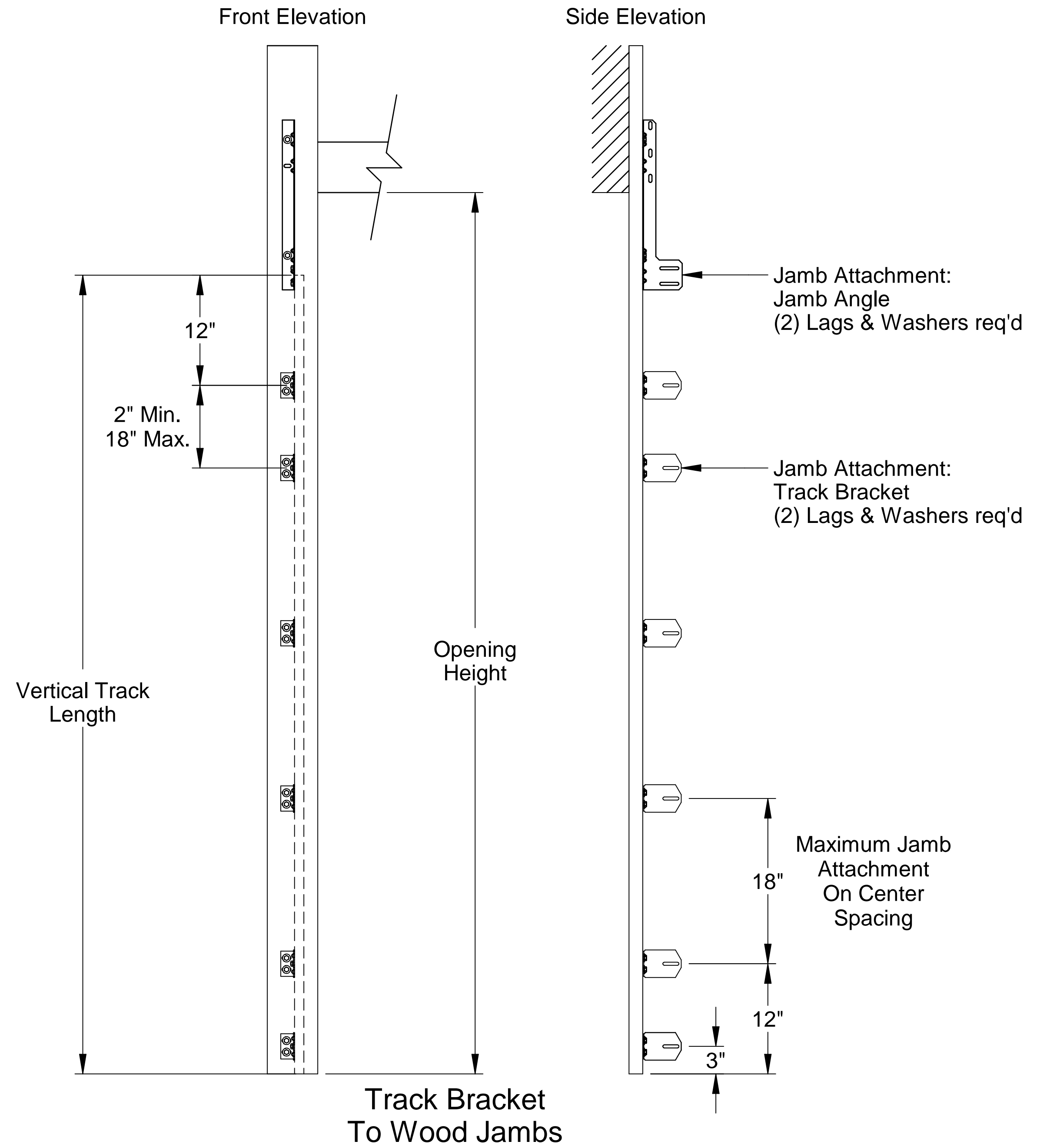
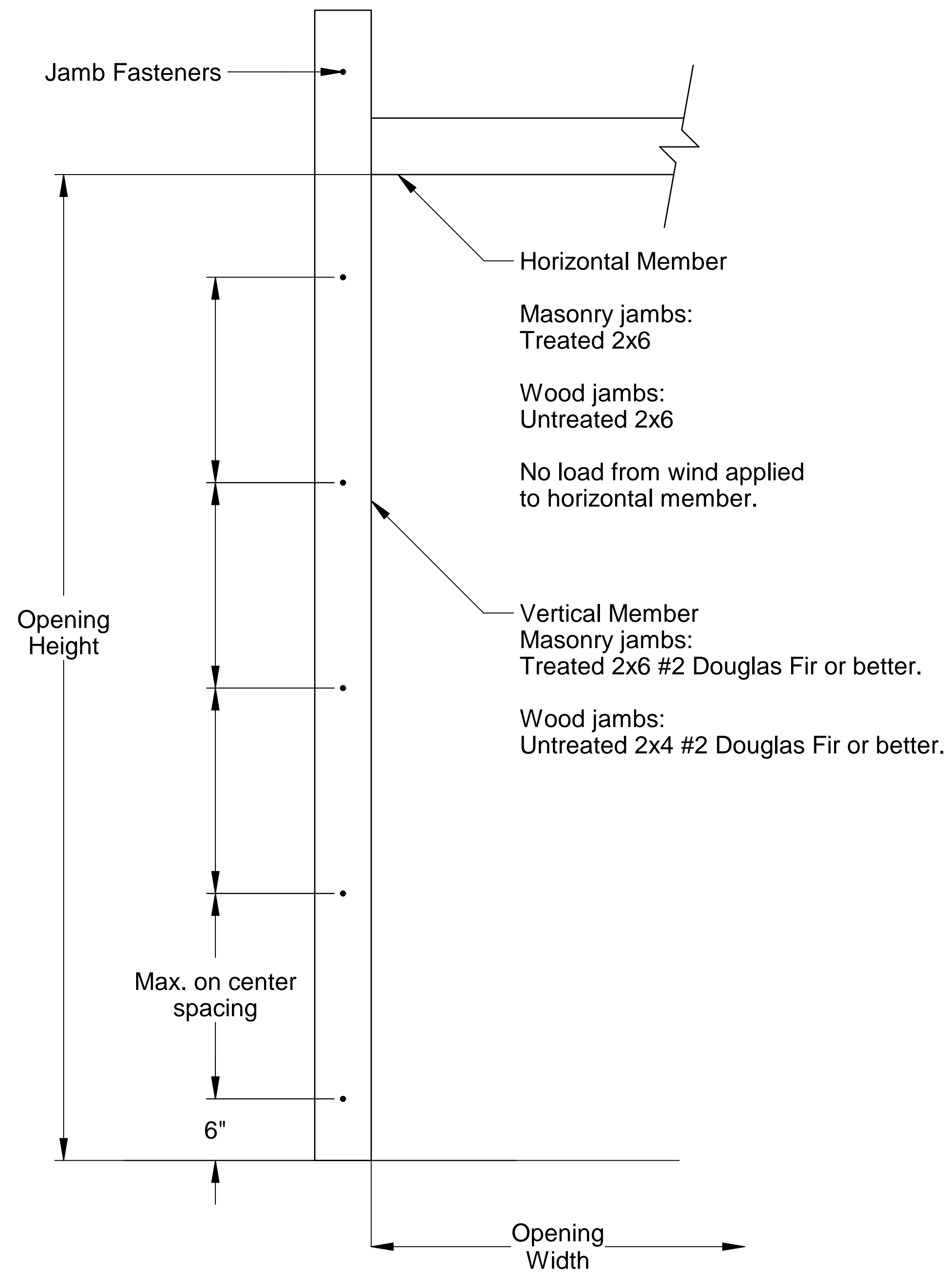

2x6 Attachment to Structure						
Structure Type	Fastener Type	Minimum Embedment	Minimum Edge Distance	Minimum on Center Spacing	Maximum on Center Spacing	Allowable Tension Load
2500 PSI Min. Concrete	1/4" Tapcon+ (Plus) with 1-1/8" OD Washer	2"	2.5	6"	23"	526
Southern Pine	3/8" x 3" Lag with 1-1/8" OD Washer	1.50"	1.50"	1.50"	24"	655
Spruce Pine Fir	3/8" x 3" LAG with 1-1/8" OD Washer	1.50"	1.50"	1.50"	21"	482

- Maximum Positive Load per Jamb = $(20'-2" \times 26.3 \text{ PSF}) / 2 = 266 \text{ lbs. per foot.}$
- Maximum Negative Load per Jamb = $(20'-2" \times -29.3 \text{ PSF}) / 2 = 296 \text{ lbs. per foot.}$
- Design of the supporting structure shall be the sole responsibility of the building designer and shall be designed for the jamb loads listed in notes 1 and 2.
- DASMA Technical Data Sheet TDS-161 may be used for alternate jamb attachments. Alternate jamb attachments may be used if approved by a registered Professional Engineer.
- 3/8" diameter lag screws required 1/4" pilot hole and 1-1/2" minimum required distance.
- Masonry fasteners by others.
- Garage doors evaluated as attached to enclosed buildings.
- Garage doors evaluated as components and cladding.



Scott A. Brown, P.E. Lic. No. 65940
 Willett, Hofmann & Associates, Inc.
 809 E. 2nd Street, Dixon, IL 61021
 FBPE CA Lic. No. 35415
 Structural Adequacy for Wind Load

Scale: None	<p>1101 East River Road Dixon, IL 61021</p>	Title: Spec, Wind Load Raynor EnergyCore	
Drawn by: J. Poitras		No. P-3410	Sheet 3
Checked by: R. Frey			Rev A
Date: 05/02/24		ECO: 9063.01	

Angle Mount to Structure:
Wall Leg Spacing

Angle Mount to Structure:
Track Leg Spacing

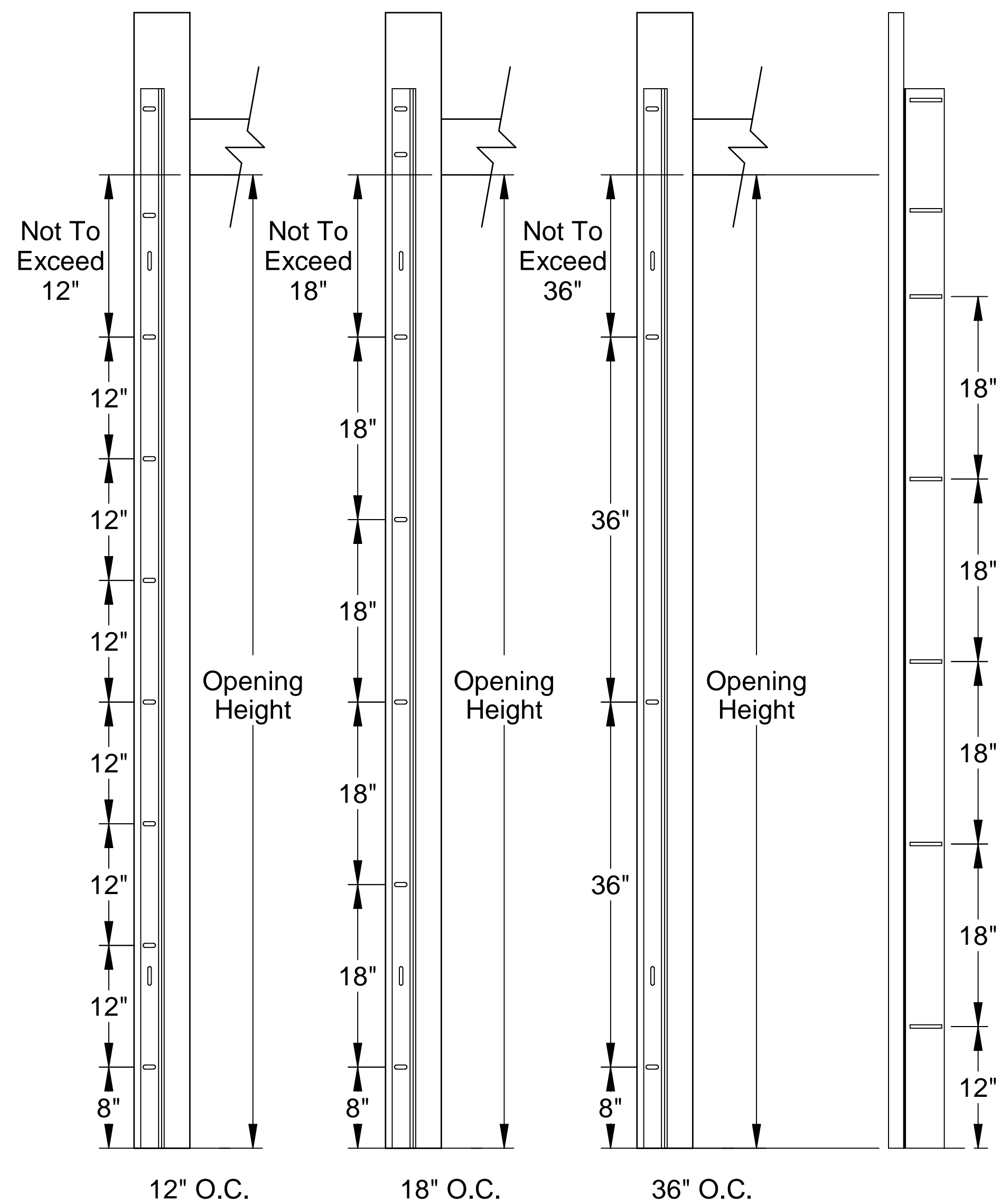

Alternate Fastener Charts

Angle Mount					
Jamb Type	Fastener Type	Minimum Embedment (in.)	Minimum Edge Distance (in.)	Maximum on Center Spacing (in.)	Allowable Tension Load (lbs.)
2500 PSI Min. Concrete	3/8" ITW Trubolt	2-1/2"	2-1/2"	36"	893
	1/4" Tapcon+ (Plus) with 1-1/8" OD Washer	2"	1-5/8"	18"	687
	1/4" x 2-5/8" Screw-Bolt+ with 9/16" OD Washer	2-1/2"	1-1/2"	18"	651
Steel	5/16" x 1-1/4" SAE J78, Min. AISI 1022 with 5/16" Washer	3/16"	1-1/2"	36"	971
Wood	5/16" x 1-3/4" Lag with 5/16" Washer	1-1/2"	1-1/2"	12"	352
Grout Filled CMU Block	3/8" Simpson Titen HD	2-3/4"	4"	18"	480

Alternate fasteners may be used if approved by a registered Professional Engineer.

Clip Angle					
Jamb Type	Fastener Type	Minimum Embedment (in.)	Minimum Edge Distance (in.)	Maximum on Center Spacing (in.)	Allowable Tension Load (lbs.)
2500 PSI Min. Concrete	3/8" ITW Trubolt	2-1/2"	2-1/2"	24"	893
	1/4" Tapcon+ (Plus) with 1-1/8" OD Washer	2"	1-5/8"	24"	687
	1/4" x 2-5/8" Screw-Bolt+ with 9/16" OD Washer	2-1/2"	1-1/2"	24"	651
Steel	5/16" x 1" SAE J78, Min. AISI 1022 with 5/16" Washer	3/16"	1-1/2"	24"	971
Wood	5/16" x 1-3/4" Lag with 5/16" Washer	1-1/2"	1-1/2"	* 12"	352
Grout Filled CMU Block	3/8" Simpson Titen HD	2-3/4"	4"	* 12"	480

Alternate fasteners may be used if approved by a registered Professional Engineer.

*Field drilling required

Clip Angle to Structure:
Wall Leg Spacing Clip Angle to Structure:
Track Leg Spacing

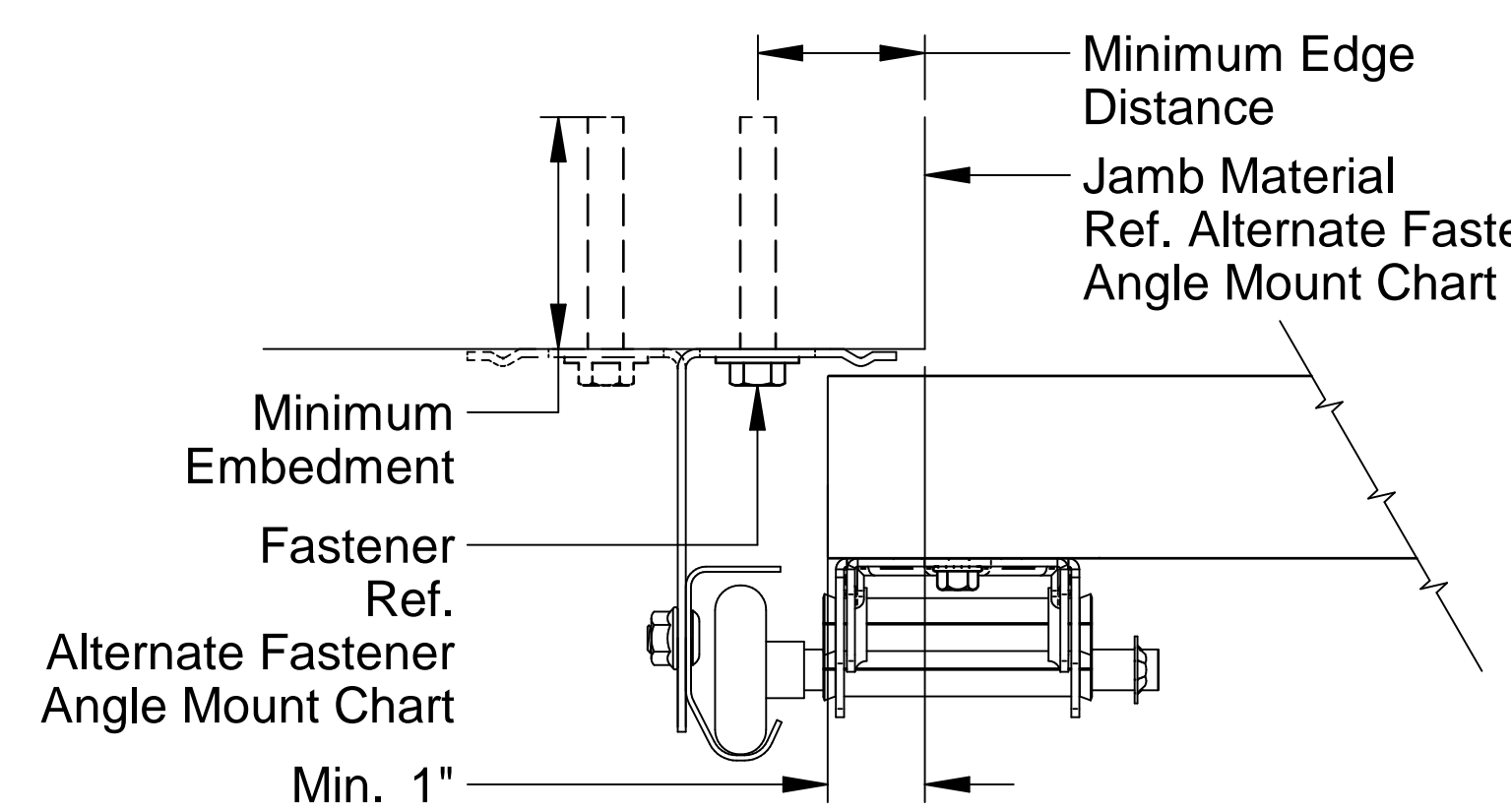
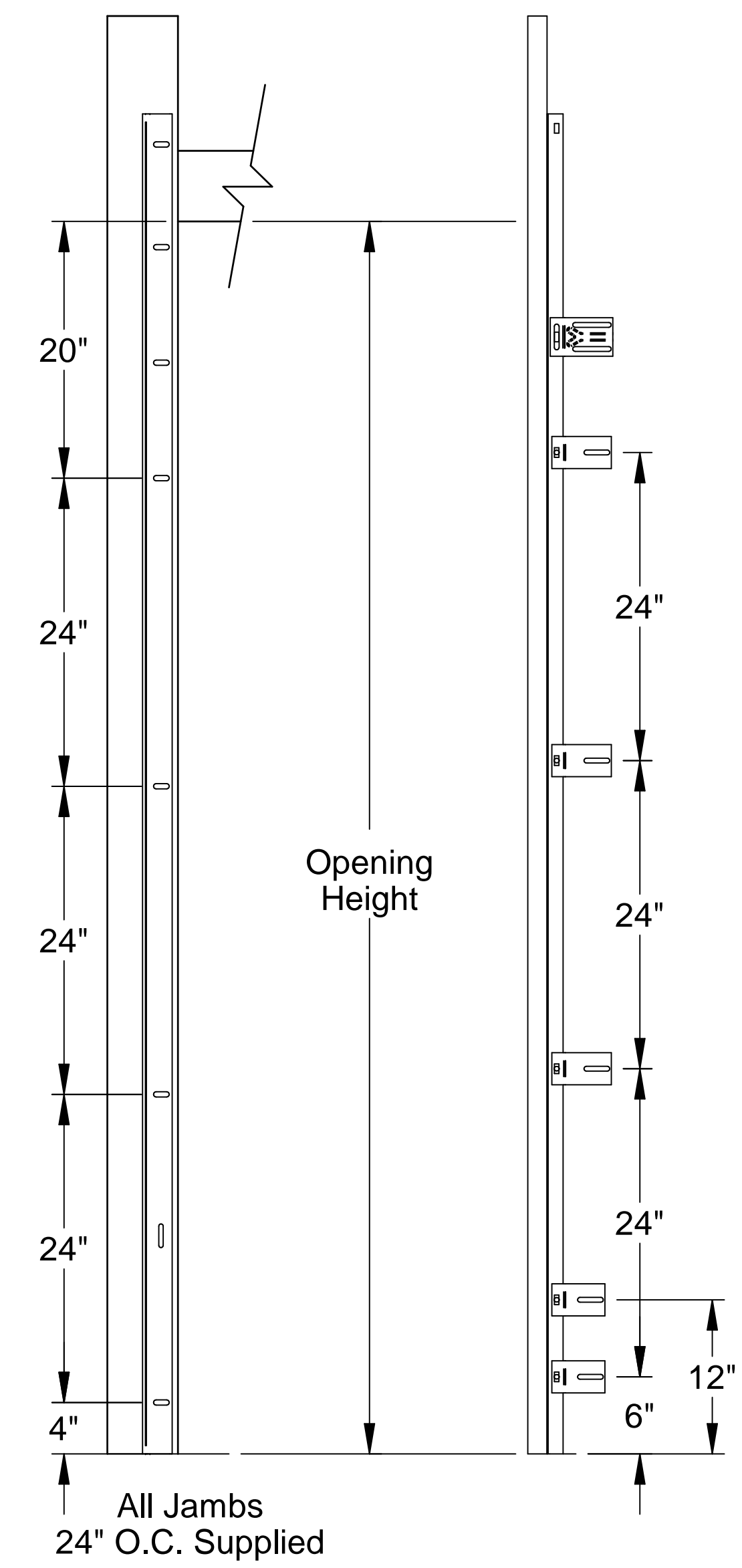

Angle Mount To Structure
2" Angle Shown
Leg-in solid, leg-out dashed
3" Available

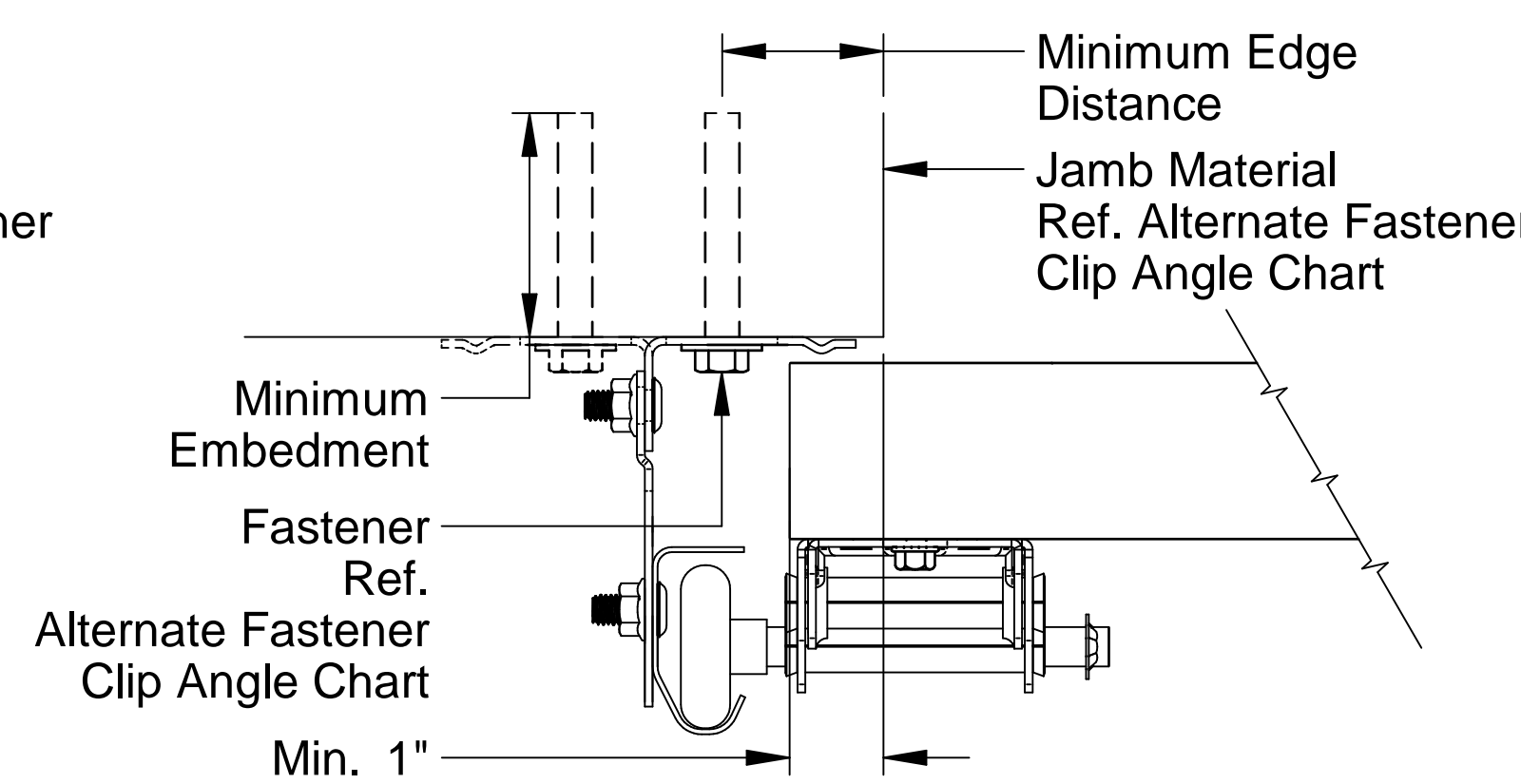

Clip Angle To Structure
2" Angle Shown
Leg-in solid, leg-out dashed
3" Available

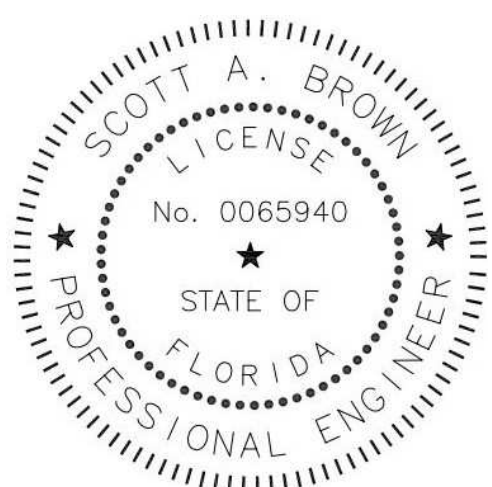

Scott A. Brown, P.E. Lic. No. 65940
Willett, Hofmann & Associates, Inc.
809 E. 2nd Street, Dixon, IL 61021
FBPE CA Lic. No. 35415
Structural Adequacy for Wind Load

Scale: None	<p>1101 East River Road Dixon, IL 61021</p>	Title: Spec, Wind Load Raynor EnergyCore	
Drawn by: J. Poitras		No. P-3410	Sheet 4
Checked by: R. Frey			
Date: 05/02/24		ECO: 9063.01	