

REVISIONS			
REV	DESCRIPTION	DATE	APPROVED

NOTES:

1. THE PRODUCT SHOWN HEREIN IS DESIGNED AND MANUFACTURED TO COMPLY WITH REQUIREMENTS OF THE FLORIDA BUILDING CODE INCLUDING THE HVHZ.
2. WOOD FRAMING AND MASONRY OPENING TO BE DESIGNED AND ANCHORED TO PROPERLY TRANSFER ALL LOADS TO STRUCTURE. FRAMING AND MASONRY OPENING IS THE RESPONSIBILITY OF THE ARCHITECT OR ENGINEER OF RECORD.
3. SHIM AS REQUIRED AT EACH ANCHOR LOCATION WITH LOAD BEARING SHIM. SHIM WHERE SPACE OF 1/16" OR GREATER OCCURS. MAXIMUM ALLOWABLE SHIM STACK TO BE 1/2".
4. SHIMS SHALL BE LOCATED, APPLIED AND MADE FROM MATERIALS AND THICKNESS CAPABLE OF SUSTAINING APPLICABLE LOADS.
5. WIND LOAD DURATION FACTOR Cd=1.6 WAS USED FOR WOOD ANCHOR CALCULATIONS.
6. FRAME MATERIAL: EXTRUDED ALUMINUM 6063-T6.
7. UNITS MUST BE GLAZED PER ASTM E1300-04/09, SEE SHEET 9 FOR GLASS DETAILS.
8. APPROVED IMPACT PROTECTIVE SYSTEM IS NOT REQUIRED FOR THIS PRODUCT IN WIND BORNE DEBRIS REGIONS WHEN INSTALLED AT 30FT OR HIGHER ABOVE GROUND LEVEL.
9. FOR ANCHORING INTO WOOD FRAMING OR 2X BUCK USE 1/2" LAG SCREWS WITH SUFFICIENT LENGTH TO ACHIEVE A 2" MINIMUM EMBEDMENT INTO SUBSTRATE. LOCATE ANCHORS AS SHOWN IN ELEVATIONS AND INSTALLATION DETAILS.
10. FOR ANCHORING INTO GROUT FILLED MASONRY OR CONCRETE USE 1/2" WEDGE BOLTS WITH SUFFICIENT LENGTH TO ACHIEVE A 3 1/2" MINIMUM EMBEDMENT INTO SUBSTRATE WITH 6" MINIMUM EDGE DISTANCE. LOCATE ANCHORS AS SHOWN IN ELEVATIONS AND INSTALLATION DETAILS.
11. FOR ANCHORING INTO METAL STRUCTURE USE 1/2"-13 SMS WITH LOCKWASHER AND NUT. LOCATE ANCHORS AS SHOWN IN ELEVATIONS AND INSTALLATION DETAILS.
12. ALL FASTENERS TO BE CORROSION RESISTANT.
13. INSTALLATION ANCHORS SHALL BE INSTALLED IN ACCORDANCE WITH ANCHOR MANUFACTURER'S INSTALLATION INSTRUCTIONS AND ANCHORS SHALL NOT BE USED IN SUBSTRATES WITH STRENGTHS LESS THAN THE MINIMUM STRENGTH SPECIFIED BELOW:
  - A. WOOD: MINIMUM SPECIFIC GRAVITY OF G=0.42
  - B. CONCRETE: MINIMUM COMPRESSIVE STRENGTH OF 2,000 PSI.
  - C. MASONRY: GROUT FILLED BLOCK PER ASTM C90 WITH Fm=2,000PSI MINIMUM.
  - D. METAL STRUCTURE: STEEL 1/4" THICK MINIMUM FY=33KSI/FU=52KSI

SIGNED: 12/15/2016

TABLE OF CONTENTS	
SHEET NO.	DESCRIPTION
1	NOTES
2 - 4	ELEVATIONS AND RATING CHARTS
5 - 8	CROSS SECTIONS
9	GLAZING DETAILS
10 - 21	INSTALLATION DETAILS
22 - 24	COMPONENTS

<b>US ALUMINUM</b> DIVISION OF C.R. LAURENCE CO., INC. 2503 E. VERNON AVE., LOS ANGELES, CA 90058		
STORM WALL XL HURRICANE RESISTANT CURTAIN WALL - WET GLAZED - SMI HVHZ NOTES		
DRAWN: R.L.	DWG NO. 08-03021	REV -
SCALE NTS	DATE 12/07/16	SHEET 1 OF 24
L. ROBERTO LOMAS P.E. 1432 WOODFORD RD LEWISVILLE, NC 27023 434-688-0609 rllomas@rlomaspe.com		

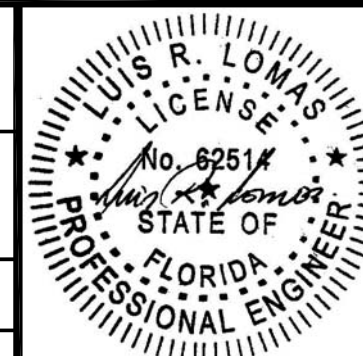

Luis R. Lomas P.E.  
FL No.: 62514

REVISIONS			
REV	DESCRIPTION	DATE	APPROVED

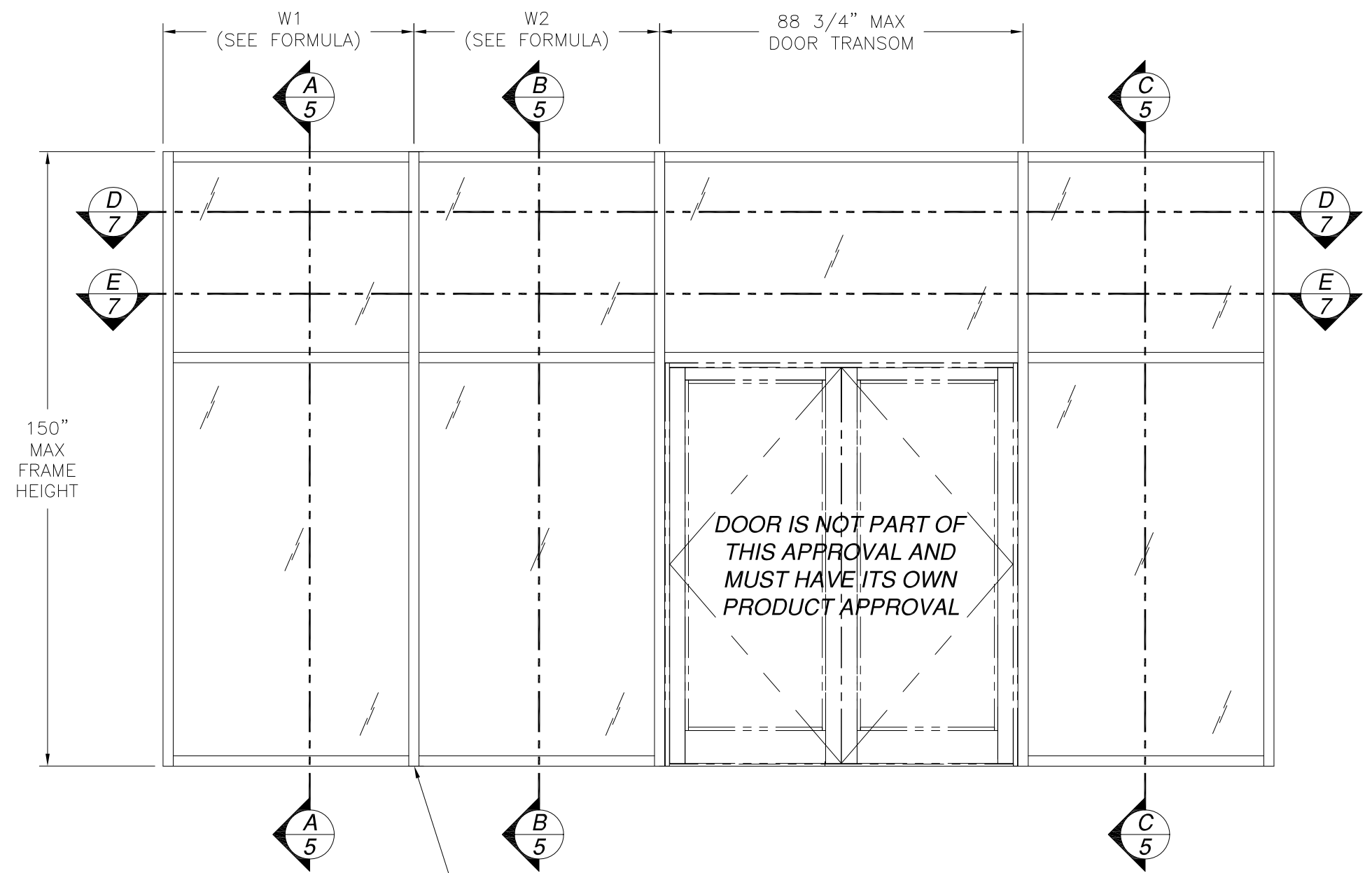

- PROCEDURE TO DETERMINE RATING:**
1. DETERMINE TRIBUTARY WIDTH PER FORMULA BELOW
  2. SELECT JAMB AND MULLION PROFILES TO BE USED FROM SHEET 7.
  3. REFER TO CHARTS IN SHEET 4 TO DETERMINE RATINGS FOR JAMB AND MULLION SELECTED IN STEP 2.
  4. DETERMINE THE TYPE OF ANCHOR CLIP AND SUBSTRATE WHERE PRODUCT IS TO BE INSTALLED. SEE SHEETS 10 - 17
  5. REFER TO CHARTS IN SHEETS 18 AND 19 TO DETERMINE RATING OF ANCHORING SELECTED IN STEP 4.
  6. SELECT GLASS TO BE USED, REFER TO SHEET 9
  7. REFER TO CHART #5 IN SHEET 9 TO DETERMINE RATING OF GLASS SELECTED IN STEP 6.
  8. THE MINIMUM OF ALL RATINGS WILL DETERMINE THE RATING OF THE TOTAL PRODUCT.

$$\text{TRIBUTARY WIDTH} = \frac{W1 + W2}{2}$$

DOOR IS NOT PART OF THIS APPROVAL AND MUST HAVE ITS OWN PRODUCT APPROVAL

FOR ANCHORING  
SEE DETAILS  
IN SHEETS 11-18  
TYP

**STORM WALL XL HURRICANE RESISTANT CURTAIN WALL**  
**SINGLE SPAN**  
 EXTERIOR VIEW  
 UNLIMITED NUMBER OF PANELS IS ALLOWED AS LONG AS INDIVIDUAL PANELS  
 AREA DO NOT EXCEED 52.25 FT<sup>2</sup>  
 AND USE VERTICAL CONDITIONS AS SHOWN

SIGNED: 12/15/2016

<b>US ALUMINUM</b> DIVISION OF C.R. LAURENCE CO., INC. 2503 E. VERNON AVE., LOS ANGELES, CA 90058		
STORM WALL XL HURRICANE RESISTANT CURTAIN WALL - WET GLAZED - SMI HVHZ SINGLE SPAN ELEVATION		
DRAWN: R.L.	DWG NO. 08-03021	REV -
SCALE NTS	DATE 12/07/16	SHEET 2 OF 24
L. ROBERTO LOMAS P.E. 1432 WOODFORD RD LEWISVILLE, NC 27023 434-688-0609 rllomas@rlomaspe.com		

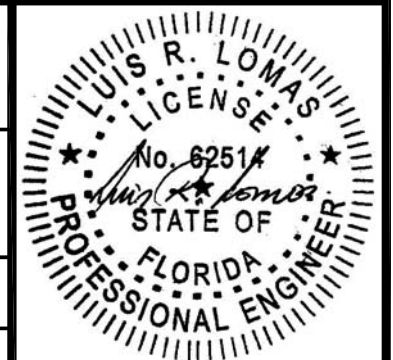

Luis R. Lomas P.E.  
FL No.: 62514

REVISIONS			
REV	DESCRIPTION	DATE	APPROVED

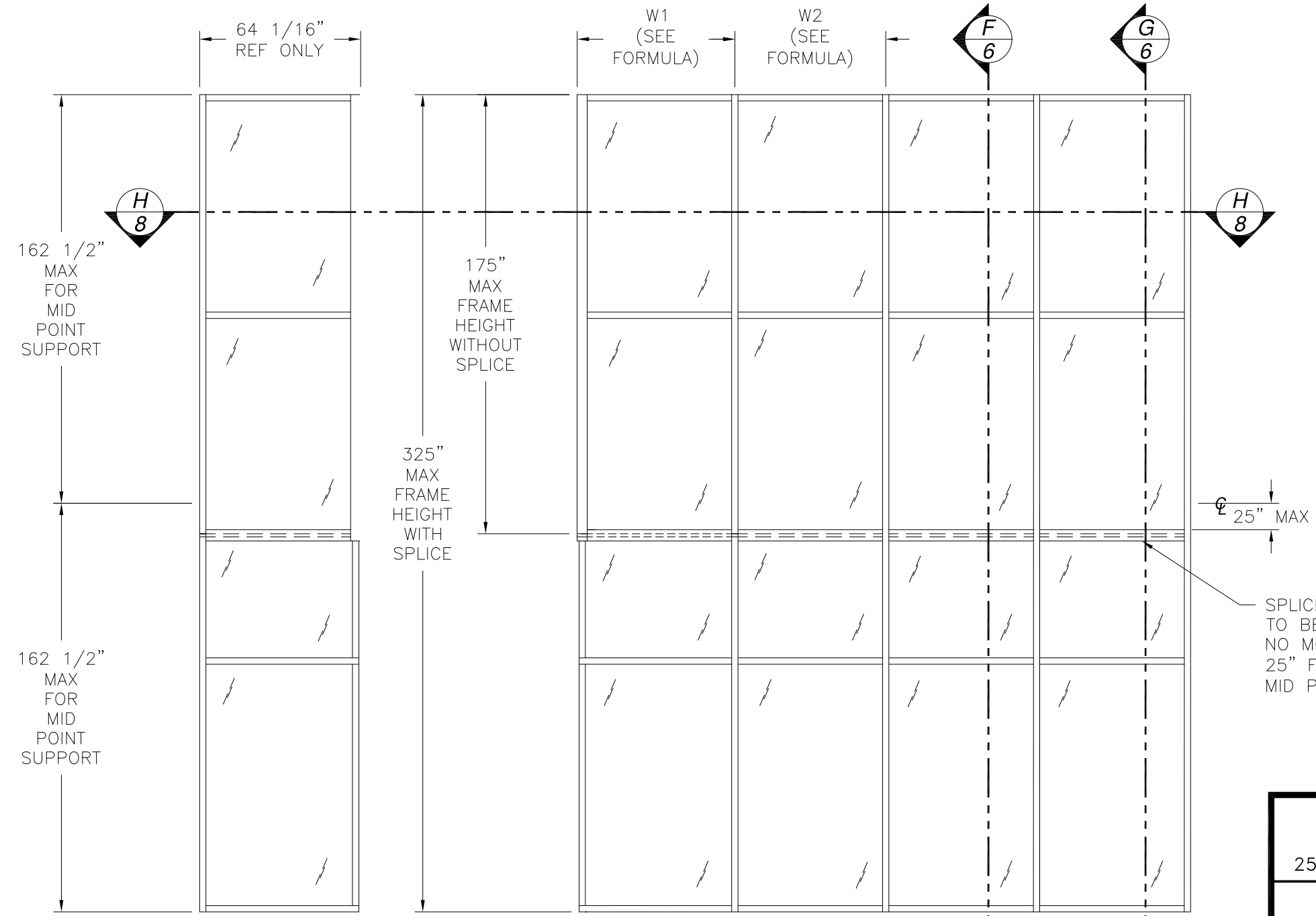

- PROCEDURE TO DETERMINE RATING:**
1. DETERMINE TRIBUTARY WIDTH PER FORMULA BELOW
  2. SELECT JAMB AND MULLION PROFILES TO BE USED FROM SHEET 7.
  3. REFER TO CHARTS IN SHEET 4 TO DETERMINE RATINGS FOR JAMB AND MULLION SELECTED IN STEP 2.
  4. DETERMINE THE TYPE OF ANCHOR CLIP AND SUBSTRATE WHERE PRODUCT IS TO BE INSTALLED. SEE SHEETS 10 - 17
  5. REFER TO CHARTS IN SHEETS 18 AND 19 TO DETERMINE RATING OF ANCHORING SELECTED IN STEP 4.
  6. SELECT GLASS TO BE USED, REFER TO SHEET 9
  7. REFER TO CHART #5 IN SHEET 9 TO DETERMINE RATING OF GLASS SELECTED IN STEP 6.
  8. THE MINIMUM OF ALL RATINGS WILL DETERMINE THE RATING OF THE TOTAL PRODUCT.

$$\text{TRIBUTARY WIDTH} = \frac{W1 + W2}{2}$$

⊕ 25" MAX

SPLICE TO BE LOCATED NO MORE THAN 25" FROM MID POINT

**STORM WALL XL TWIN SPAN**  
 EXTERIOR VIEW  
 UNLIMITED NUMBER OF PANELS IS ALLOWED AS LONG AS INDIVIDUAL PANELS  
 AREA DO NOT EXCEED 52.25 FT<sup>2</sup>  
 AND USE VERTICAL CONDITIONS AS SHOWN

**US ALUMINUM**  
 DIVISION OF C.R. LAURENCE CO., INC.  
 2503 E. VERNON AVE., LOS ANGELES, CA 90058

STORM WALL XL HURRICANE RESISTANT  
 CURTAIN WALL – WET GLAZED – SMI HVHZ  
 TWIN SPAN ELEVATION

DRAWN: R.L.	DWG NO. 08-03021	REV -
SCALE NTS	DATE 12/07/16	SHEET 3 OF 24

L. ROBERTO LOMAS P.E.  
 1432 WOODFORD RD LEWISVILLE, NC 27023  
 434-688-0609 rllomas@rlomaspe.com

SIGNED: 12/15/2016



Luis R. Lomas P.E.  
 FL No.: 62514

**Chart #1**  
**Design pressure for Mullion "A", "B" and "C" (psf)**  
**Design pressure for Jamb "B" and "C" (psf)**

Frame Height (in)	Design pressures are positive and negative								
	Tributary Width (in)								
	24.0	30.0	36.0	42.0	48.0	54.0	60.0	66.0	72.0
60.0	100.0	100.0	100.0	100.0	100.0	100.0	100.0	100.0	100.0
66.0	100.0	100.0	100.0	100.0	100.0	100.0	100.0	100.0	100.0
72.0	100.0	100.0	100.0	100.0	100.0	100.0	100.0	100.0	100.0
78.0	100.0	100.0	100.0	100.0	100.0	100.0	100.0	100.0	100.0
84.0	100.0	100.0	100.0	100.0	100.0	100.0	100.0	100.0	100.0
90.0	100.0	100.0	100.0	100.0	100.0	100.0	100.0	100.0	100.0
96.0	100.0	100.0	100.0	100.0	100.0	100.0	100.0	100.0	100.0
102.0	100.0	100.0	100.0	100.0	100.0	100.0	100.0	100.0	100.0
108.0	100.0	100.0	100.0	100.0	100.0	100.0	100.0	100.0	100.0
114.0	100.0	100.0	100.0	100.0	100.0	100.0	100.0	100.0	100.0
120.0	100.0	100.0	100.0	100.0	100.0	100.0	100.0	100.0	100.0
126.0	100.0	100.0	100.0	100.0	100.0	100.0	100.0	100.0	99.2
132.0	100.0	100.0	100.0	100.0	100.0	100.0	100.0	100.0	94.7
138.0	100.0	100.0	100.0	100.0	100.0	100.0	100.0	98.8	90.6
144.0	100.0	100.0	100.0	100.0	100.0	100.0	100.0	94.7	86.8
150.0	100.0	100.0	100.0	100.0	100.0	100.0	100.0	90.9	83.3

SMALL MISSILE IMPACT AND HVHZ

**Chart #2**  
**Design pressure for Mullion "D" (psf)**  
**Design pressure for Jamb "A" (psf)**

Frame Height (in)	Design pressures are positive and negative								
	Tributary Width (in)								
	24.0	30.0	36.0	42.0	48.0	54.0	60.0	66.0	72.0
60.0	65.0	65.0	65.0	65.0	65.0	65.0	65.0	65.0	65.0
66.0	65.0	65.0	65.0	65.0	65.0	65.0	65.0	65.0	65.0
72.0	65.0	65.0	65.0	65.0	65.0	65.0	65.0	65.0	60.2
78.0	65.0	65.0	65.0	65.0	65.0	65.0	65.0	60.6	55.6
84.0	65.0	65.0	65.0	65.0	65.0	65.0	61.9	56.3	51.6
90.0	65.0	65.0	65.0	65.0	65.0	64.2	57.8	52.5	48.2
96.0	65.0	65.0	65.0	65.0	65.0	60.2	54.2	49.3	45.1
102.0	65.0	65.0	65.0	65.0	63.7	56.7	51.0	46.4	42.5
108.0	65.0	65.0	65.0	65.0	57.4	51.1	46.0	41.8	38.3
114.0	65.0	65.0	65.0	55.8	48.8	43.4	39.1	35.5	32.6
120.0	65.0	65.0	55.8	47.9	41.9	37.2	33.5	30.5	27.9

SMALL MISSILE IMPACT AND HVHZ

**Chart #3**  
**Design pressure for Mullion "A", "B" and "G" (psf)**  
**Design pressure for Jamb "C" and Corner (psf)**

Frame Height (in)	Design pressures are positive and negative								
	Tributary Width (in)								
	24.0	30.0	36.0	42.0	48.0	54.0	60.0	66.0	72.0
60.0	100.0	100.0	100.0	100.0	100.0	100.0	100.0	100.0	100.0
66.0	100.0	100.0	100.0	100.0	100.0	100.0	100.0	100.0	100.0
72.0	100.0	100.0	100.0	100.0	100.0	100.0	100.0	100.0	100.0
78.0	100.0	100.0	100.0	100.0	100.0	100.0	100.0	100.0	100.0
84.0	100.0	100.0	100.0	100.0	100.0	100.0	100.0	100.0	100.0
90.0	100.0	100.0	100.0	100.0	100.0	100.0	100.0	100.0	100.0
96.0	100.0	100.0	100.0	100.0	100.0	100.0	100.0	100.0	100.0
102.0	100.0	100.0	100.0	100.0	100.0	100.0	100.0	100.0	100.0
108.0	100.0	100.0	100.0	100.0	100.0	100.0	100.0	100.0	100.0
114.0	100.0	100.0	100.0	100.0	100.0	100.0	100.0	100.0	100.0
120.0	100.0	100.0	100.0	100.0	100.0	100.0	100.0	100.0	100.0
126.0	100.0	100.0	100.0	100.0	100.0	100.0	100.0	100.0	100.0
132.0	100.0	100.0	100.0	100.0	100.0	100.0	100.0	100.0	100.0
138.0	100.0	100.0	100.0	100.0	100.0	100.0	100.0	100.0	100.0
144.0	100.0	100.0	100.0	100.0	100.0	100.0	100.0	100.0	100.0
150.0	100.0	100.0	100.0	100.0	100.0	100.0	100.0	100.0	97.2
156.0	100.0	100.0	100.0	100.0	100.0	100.0	100.0	100.0	93.5
162.0	100.0	100.0	100.0	100.0	100.0	100.0	100.0	98.2	90.0
168.0	100.0	100.0	100.0	100.0	100.0	100.0	100.0	94.7	86.8
174.0	100.0	100.0	100.0	100.0	100.0	100.0	100.0	91.4	83.8
175.0	100.0	100.0	100.0	100.0	100.0	100.0	100.0	90.9	83.3

SMALL MISSILE IMPACT AND HVHZ  
 FULL LENGTH WITHOUT SPLICE

**Chart #4**  
**Design pressure for Mullion "A", "B" and "G" with splice (psf)**  
**Design pressure for Jamb "C" and Corner with splice (psf)**

Frame Height (in)	Design pressures are positive and negative								
	Tributary Width (in)								
	24.0	30.0	36.0	42.0	48.0	54.0	60.0	66.0	72.0
210.0	100.0	100.0	100.0	100.0	100.0	100.0	100.0	100.0	100.0
216.0	100.0	100.0	100.0	100.0	100.0	100.0	100.0	100.0	100.0
222.0	100.0	100.0	100.0	100.0	100.0	100.0	100.0	100.0	100.0
228.0	100.0	100.0	100.0	100.0	100.0	100.0	100.0	100.0	100.0
234.0	100.0	100.0	100.0	100.0	100.0	100.0	100.0	100.0	100.0
240.0	100.0	100.0	100.0	100.0	100.0	100.0	100.0	100.0	100.0
246.0	100.0	100.0	100.0	100.0	100.0	100.0	100.0	100.0	100.0
252.0	100.0	100.0	100.0	100.0	100.0	100.0	100.0	100.0	100.0
258.0	100.0	100.0	100.0	100.0	100.0	100.0	100.0	100.0	100.0
264.0	100.0	100.0	100.0	100.0	100.0	100.0	100.0	100.0	100.0
270.0	100.0	100.0	100.0	100.0	100.0	100.0	100.0	100.0	100.0
276.0	100.0	100.0	100.0	100.0	100.0	100.0	100.0	100.0	98.1
282.0	100.0	100.0	100.0	100.0	100.0	100.0	100.0	100.0	96.0
288.0	100.0	100.0	100.0	100.0	100.0	100.0	100.0	100.0	94.0
294.0	100.0	100.0	100.0	100.0	100.0	100.0	100.0	100.0	92.1
300.0	100.0	100.0	100.0	100.0	100.0	100.0	100.0	98.5	90.3
306.0	100.0	100.0	100.0	100.0	100.0	100.0	100.0	96.6	88.5
312.0	100.0	100.0	100.0	100.0	100.0	100.0	100.0	94.7	86.8
318.0	100.0	100.0	100.0	100.0	100.0	100.0	100.0	92.9	85.2
324.0	100.0	100.0	100.0	100.0	100.0	100.0	100.0	91.2	83.6
325.0	100.0	100.0	100.0	100.0	100.0	100.0	100.0	90.9	83.3

SMALL MISSILE IMPACT AND HVHZ  
 FULL LENGTH WITH SUPPORT AT MIDDLE POINT AND SPLICE  
 DISTANCE BETWEEN SPLICE AND MID POINT MUST NOT EXCEED 25"

REVISIONS			
REV	DESCRIPTION	DATE	APPROVED

SIGNED: 12/15/2016

**US ALUMINUM**  
 DIVISION OF C.R. LAURENCE CO., INC.  
 2503 E. VERNON AVE., LOS ANGELES, CA 90058

STORM WALL XL HURRICANE RESISTANT  
 CURTAIN WALL – WET GLAZED – SMI HVHZ  
 MULLION AND JAMB CHARTS

DRAWN: R.L.	DWG NO. 08-03021	REV -
SCALE NTS	DATE 12/07/16	SHEET 4 OF 24

L. ROBERTO LOMAS P.E.  
 1432 WOODFORD RD LEWISVILLE, NC 27023  
 434-688-0609 rllomas@rlomaspe.com

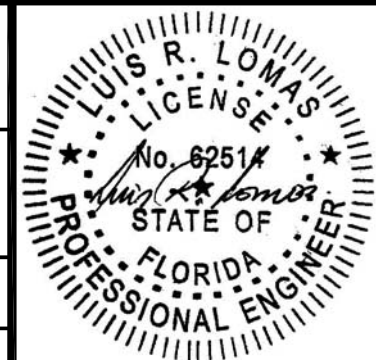

Luis R. Lomas P.E.  
 FL No.: 62514

**FOR ILLUSTRATION PURPOSES ONLY**  
**FOR INSTALLATION DETAILS SEE SHEETS 10 - 17**

REVISIONS			
REV	DESCRIPTION	DATE	APPROVED

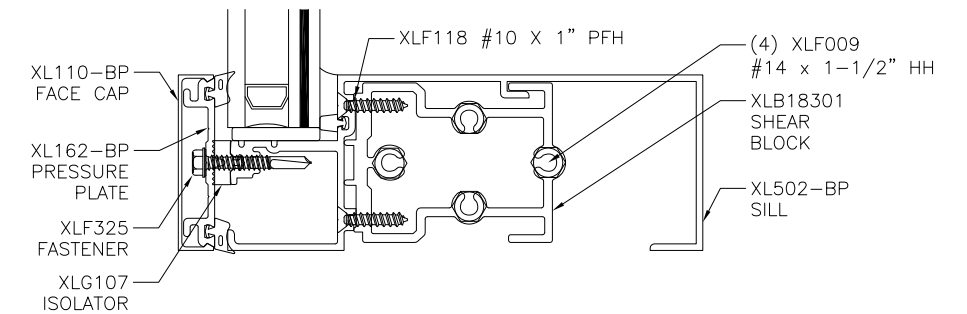
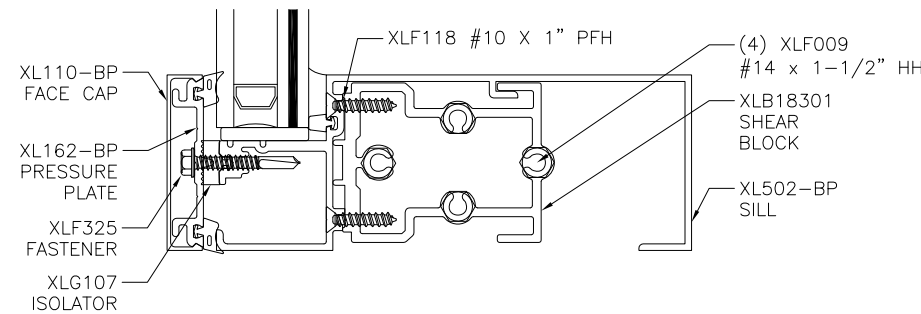
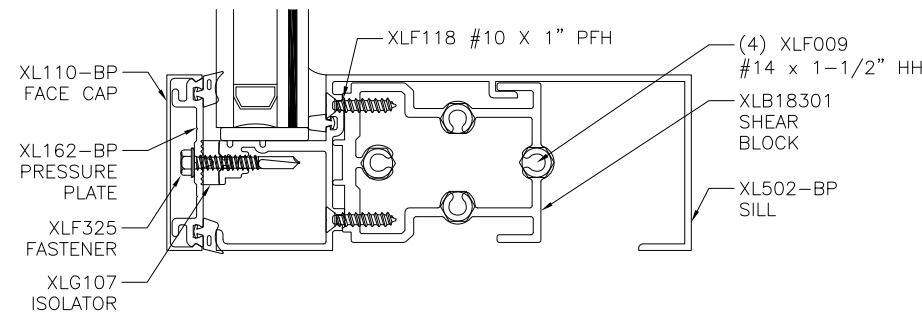
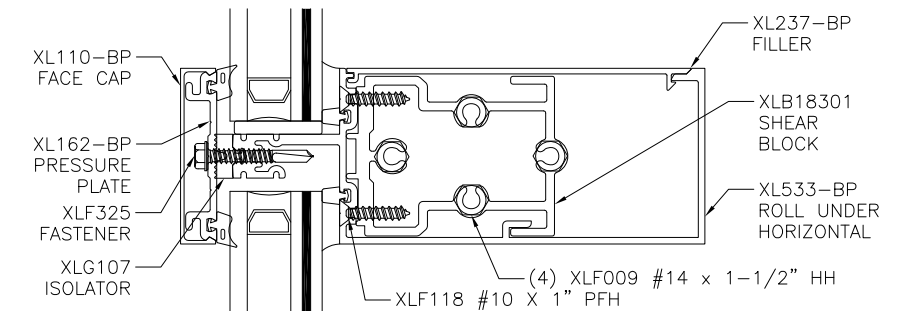
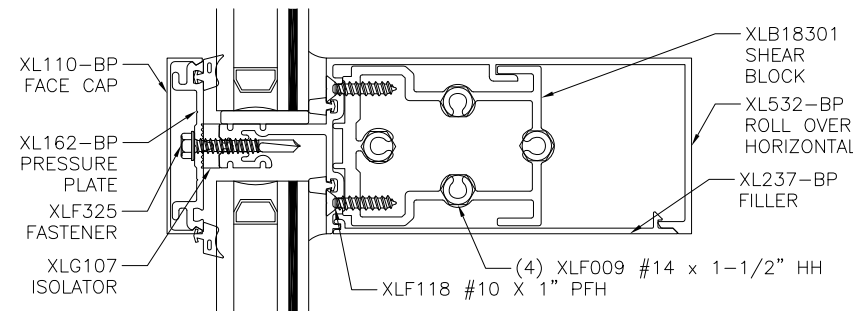
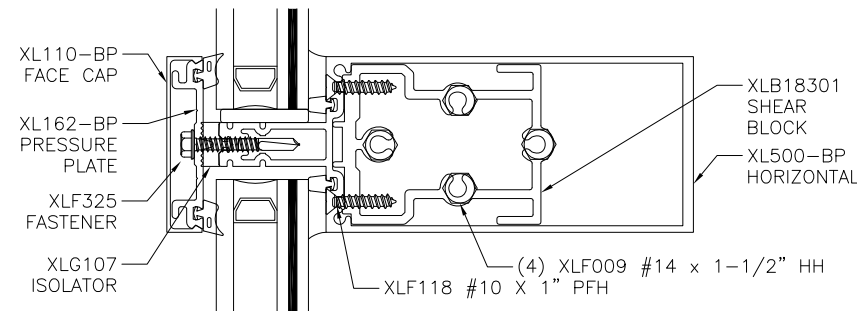
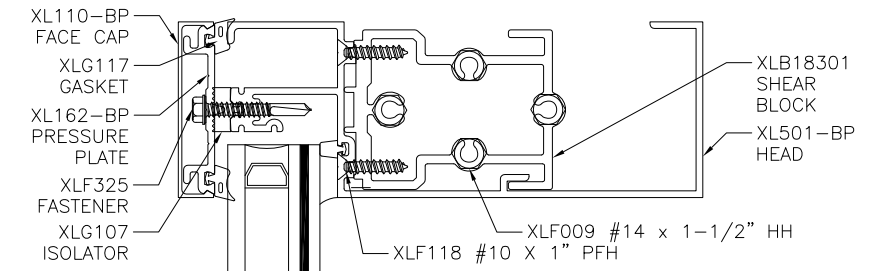
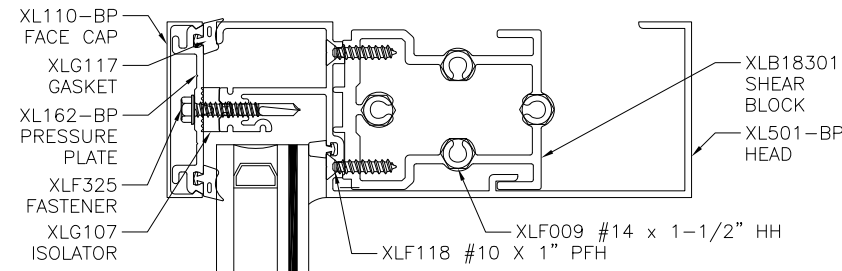
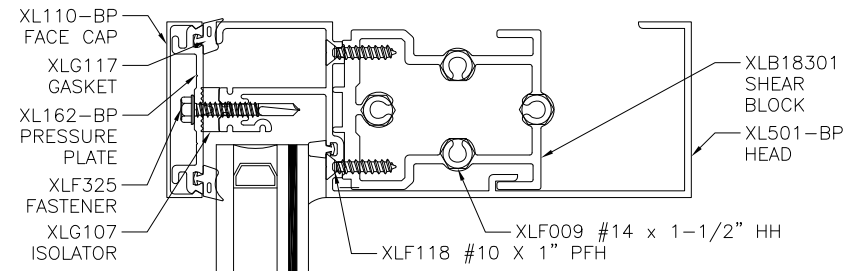

**A**  
5 VERTICAL CROSS SECTION

**B**  
5 VERTICAL CROSS SECTION

**C**  
5 VERTICAL CROSS SECTION

SIGNED: 12/15/2016

**US ALUMINUM**  
 DIVISION OF C.R. LAURENCE CO., INC.  
 2503 E. VERNON AVE., LOS ANGELES, CA 90058

STORM WALL XL HURRICANE RESISTANT  
 CURTAIN WALL - WET GLAZED - SMI HVHZ  
 VERTICAL CROSS SECTIONS

DRAWN: R.L.	DWG NO. 08-03021	REV -
SCALE NTS	DATE 12/07/16	SHEET 5 OF 24

L. ROBERTO LOMAS P.E.  
 1432 WOODFORD RD LEWISVILLE, NC 27023  
 434-688-0609 rllomas@rlomaspe.com



Luis R. Lomas P.E.  
 FL No.: 62514

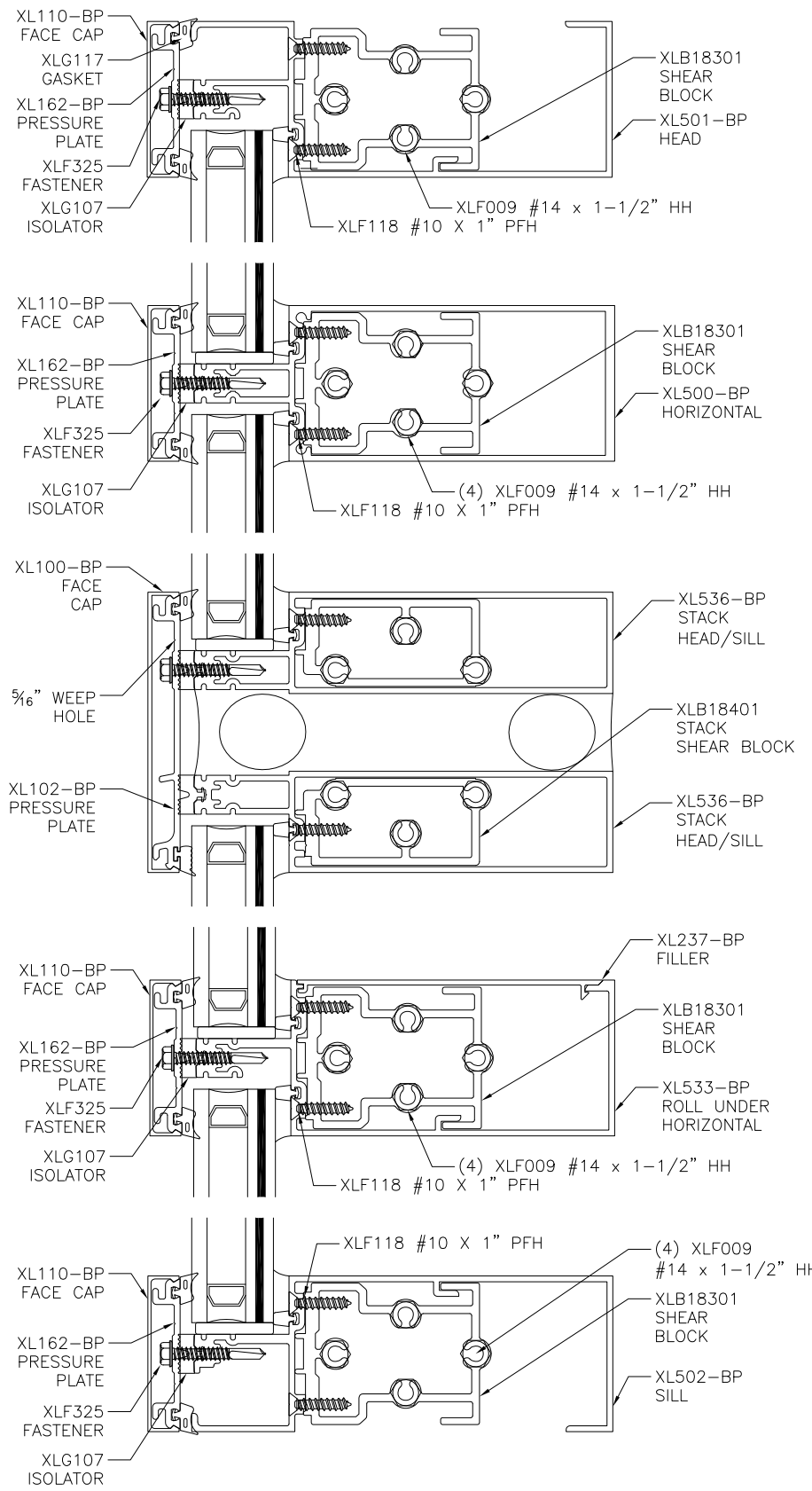

**F**  
6 VERTICAL CROSS SECTION

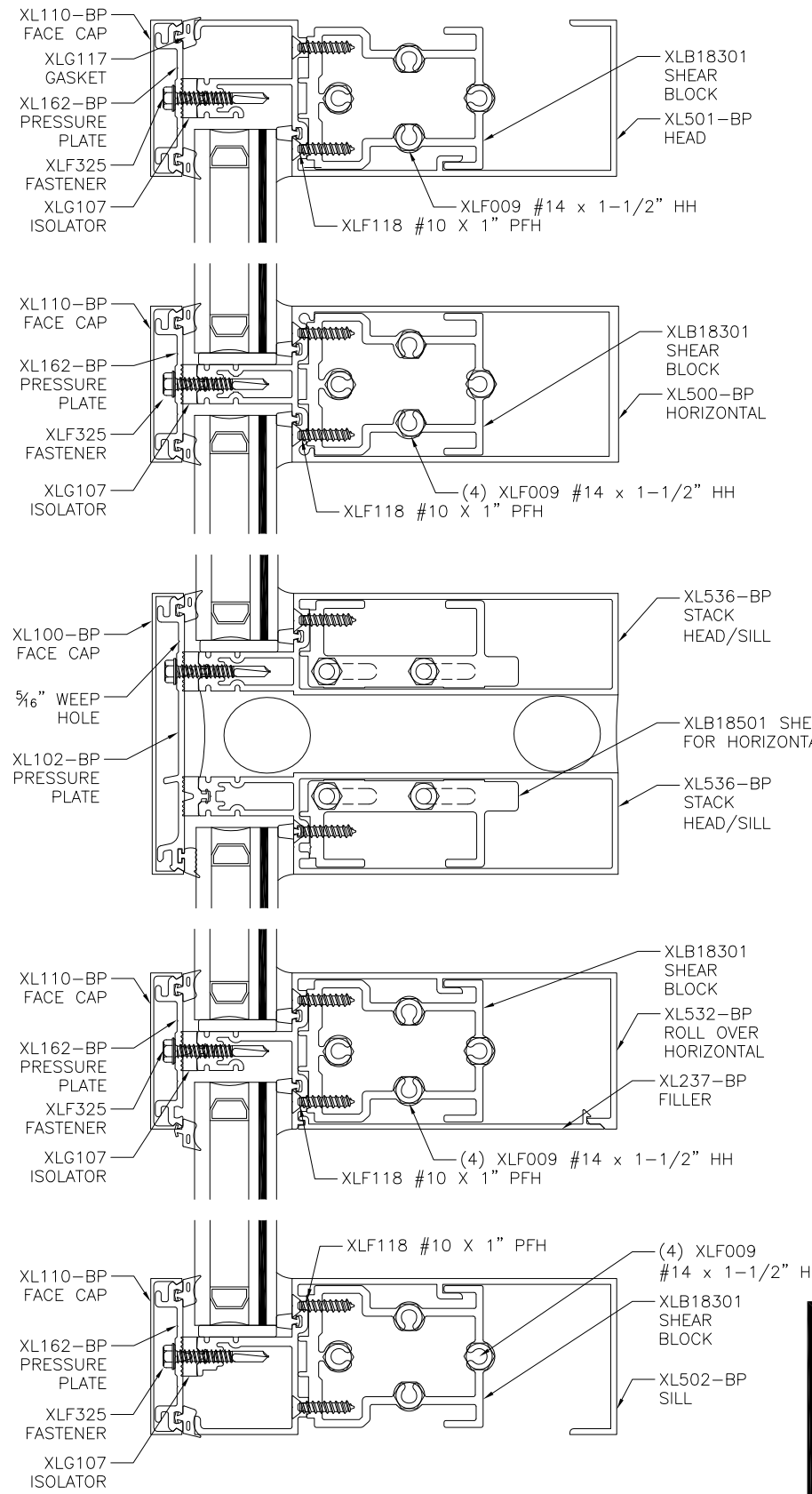

**G**  
6 VERTICAL CROSS SECTION

REVISIONS			
REV	DESCRIPTION	DATE	APPROVED

**US ALUMINUM**  
DIVISION OF C.R. LAURENCE CO., INC.  
2503 E. VERNON AVE., LOS ANGELES, CA 90058

STORM WALL XL HURRICANE RESISTANT  
CURTAIN WALL - WET GLAZED - SMI HVHZ  
VERTICAL CROSS SECTIONS

DRAWN: R.L.	DWG NO. 08-03021	REV -
SCALE NTS	DATE 12/07/16	SHEET 6 OF 24

L. ROBERTO LOMAS P.E.  
1432 WOODFORD RD LEWISVILLE, NC 27023  
434-688-0609 rllomas@rlomaspe.com

SIGNED: 12/15/2016



Luis R. Lomas P.E.  
FL No.: 62514

**FOR ILLUSTRATION PURPOSES ONLY**  
**FOR INSTALLATION DETAILS SEE SHEETS 10 - 17**

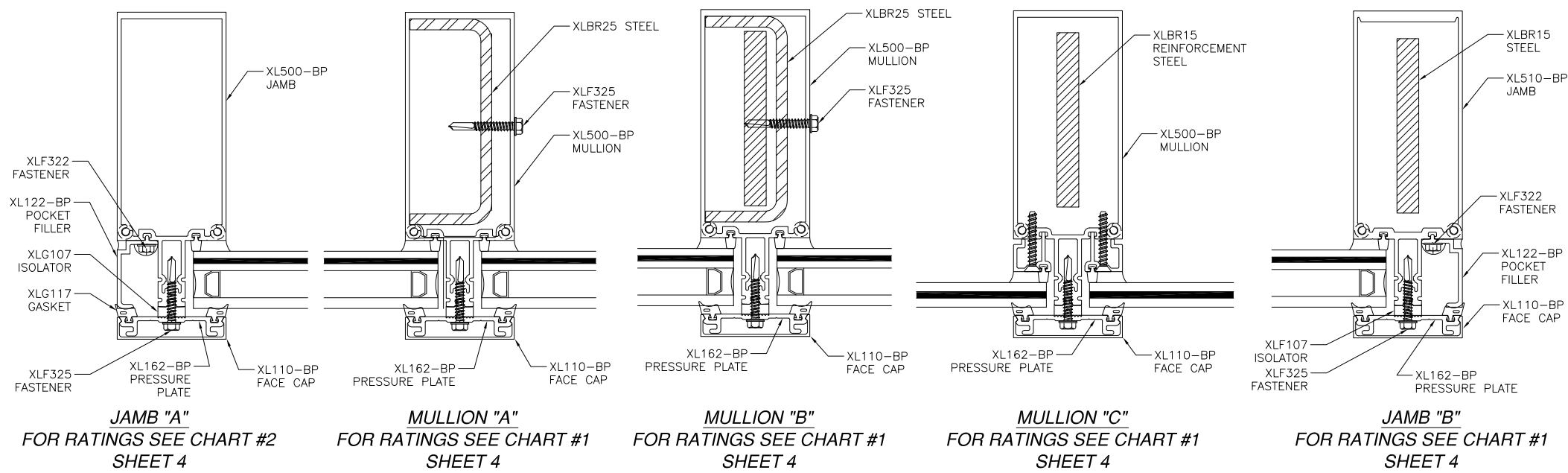

**D**  
7 **HORIZONTAL CROSS SECTION**

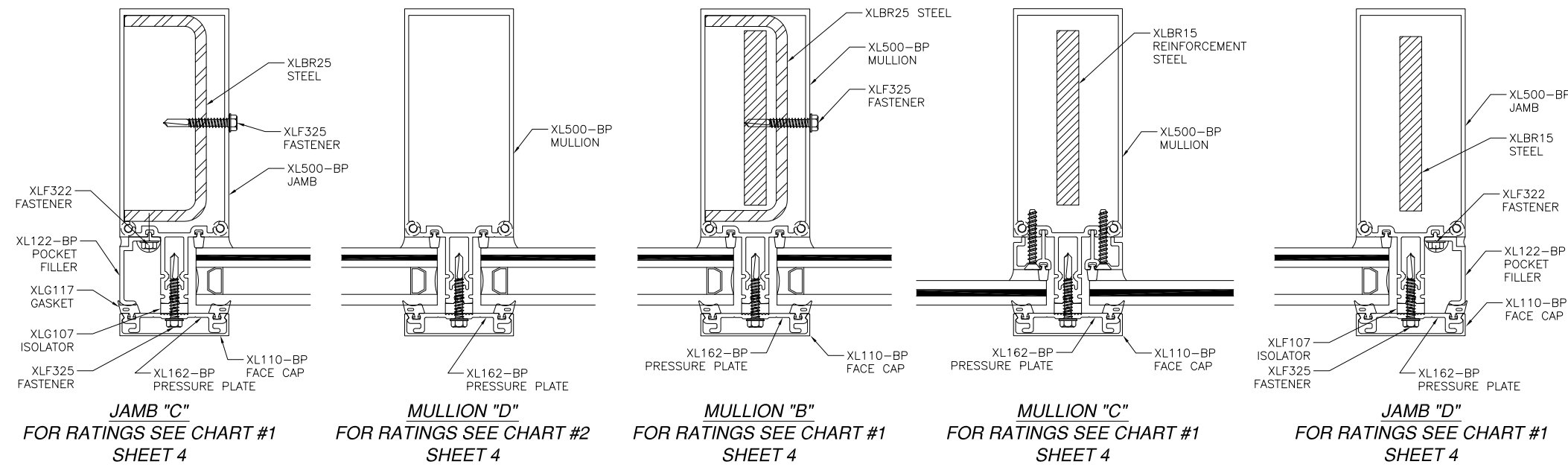

**E**  
7 **HORIZONTAL CROSS SECTION**

**FOR ILLUSTRATION PURPOSES ONLY**  
**FOR INSTALLATION DETAILS SEE SHEETS 10 - 17**

REVISIONS			
REV	DESCRIPTION	DATE	APPROVED

US ALUMINUM  
DIVISION OF C.R. LAURENCE CO., INC.  
2503 E. VERNON AVE., LOS ANGELES, CA 90058

STORM WALL XL HURRICANE RESISTANT  
CURTAIN WALL - WET GLAZED - SMI HVHZ  
HORIZONTAL CROSS SECTIONS

DRAWN: R.L.	DWG NO. 08-03021	REV -
SCALE NTS	DATE 12/07/16	SHEET 7 OF 24

L. ROBERTO LOMAS P.E.  
1432 WOODFORD RD LEWISVILLE, NC 27023  
434-688-0609 rllomas@rlomaspe.com

SIGNED: 12/15/2016

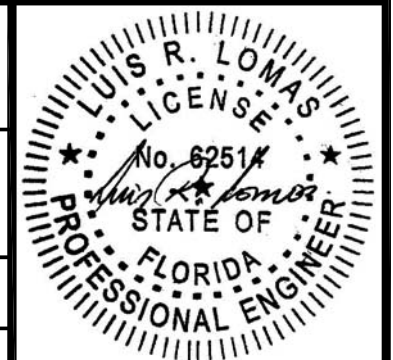

Luis R. Lomas P.E.  
FL No.: 62514

REVISIONS			
REV	DESCRIPTION	DATE	APPROVED

**FOR ILLUSTRATION PURPOSES ONLY**  
**FOR INSTALLATION DETAILS SEE SHEETS 10 - 17**

JAMB "C"  
 FOR RATINGS  
 SEE  
 CHARTS #5 & #6  
 SHEET 4

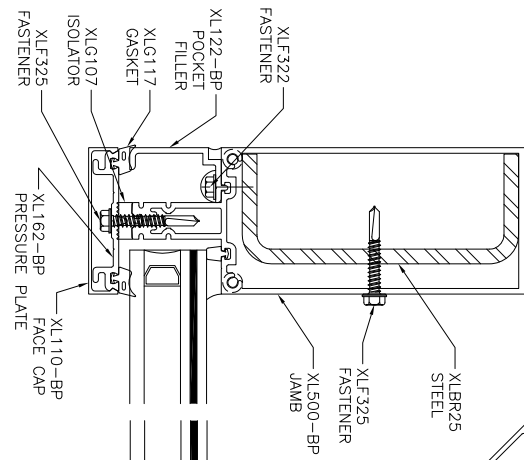

**CORNER MULLION**  
 FOR RATINGS SEE CHARTS #3 & #4

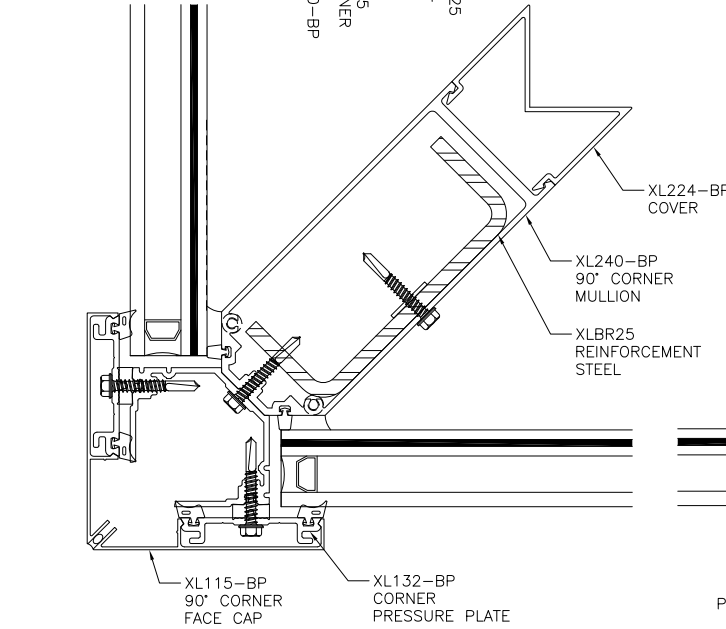

**MULLION "A"**  
 FOR RATINGS SEE CHARTS #3 & #4

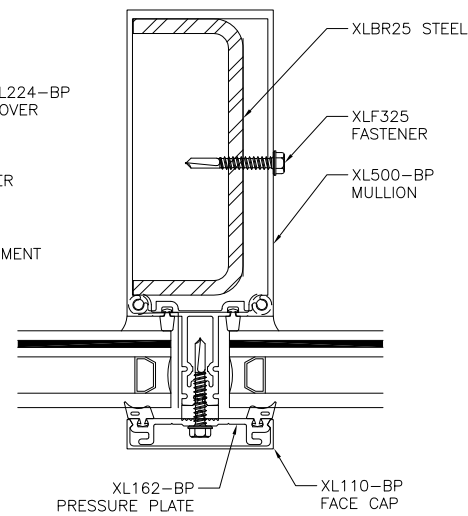

**MULLION "B"**  
 FOR RATINGS SEE CHARTS #3 & #4

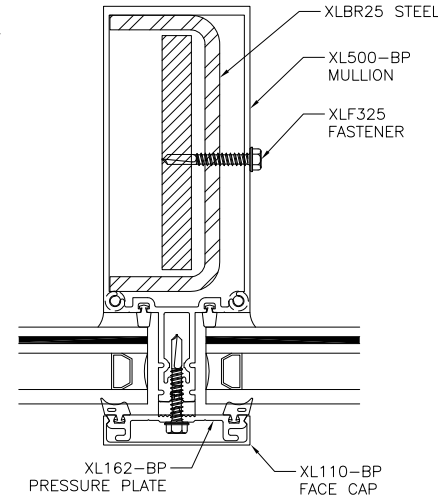

**MULLION "G"**  
 FOR RATINGS SEE CHARTS #3 & #4

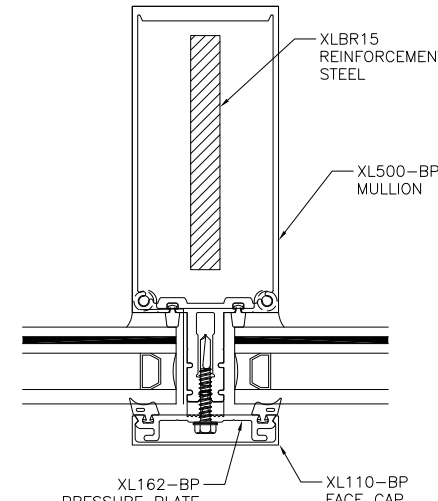

**JAMB "C"**  
 FOR RATINGS SEE CHARTS #3 & #4

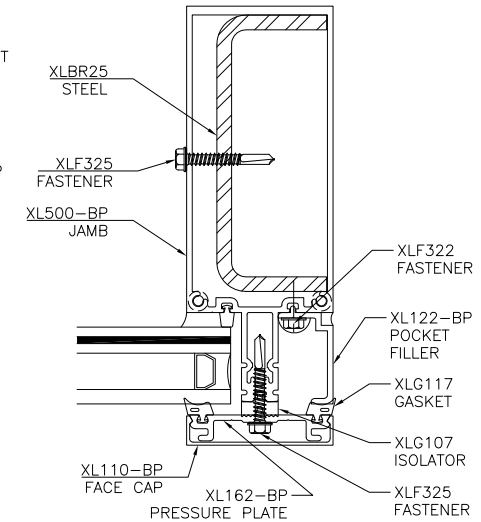

**H**  
**8** HORIZONTAL CROSS SECTION

SIGNED: 12/15/2016

**US ALUMINUM**  
 DIVISION OF C.R. LAURENCE CO., INC.  
 2503 E. VERNON AVE., LOS ANGELES, CA 90058

STORM WALL XL HURRICANE RESISTANT  
 CURTAIN WALL - WET GLAZED - SMI HVHZ  
 HORIZONTAL CROSS SECTIONS

DRAWN: R.L.	DWG NO. 08-03021	REV -
SCALE NTS	DATE 12/07/16	SHEET 8 OF 24

L. ROBERTO LOMAS P.E.  
 1432 WOODFORD RD LEWISVILLE, NC 27023  
 434-688-0609 rllomas@rlomaspe.com

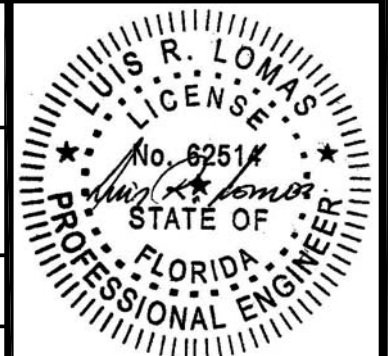

Luis R. Lomas P.E.  
 FL No.: 62514



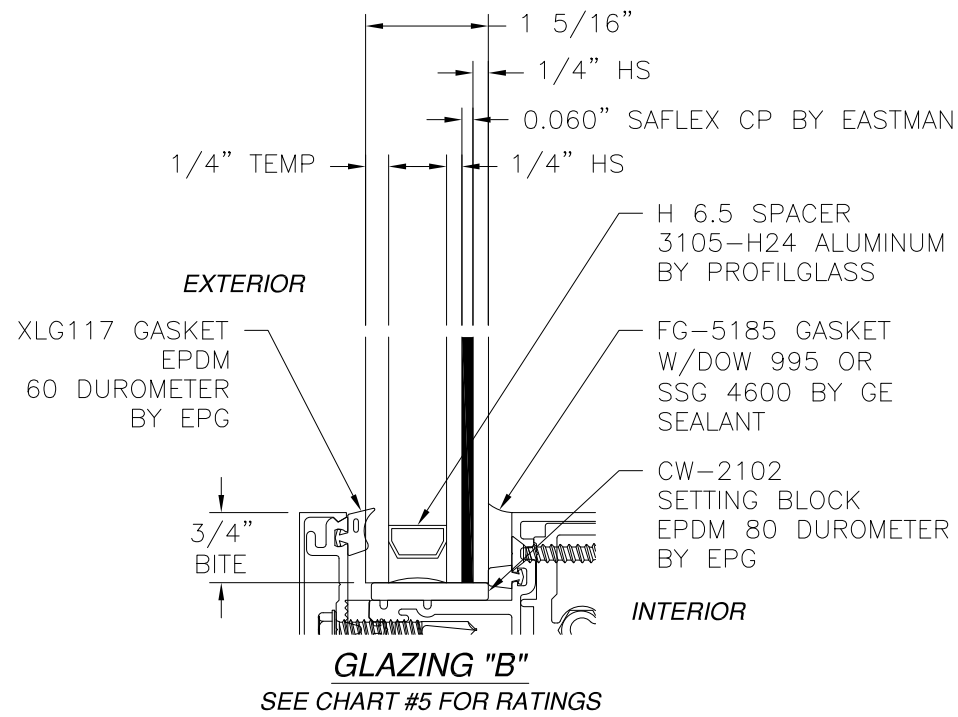
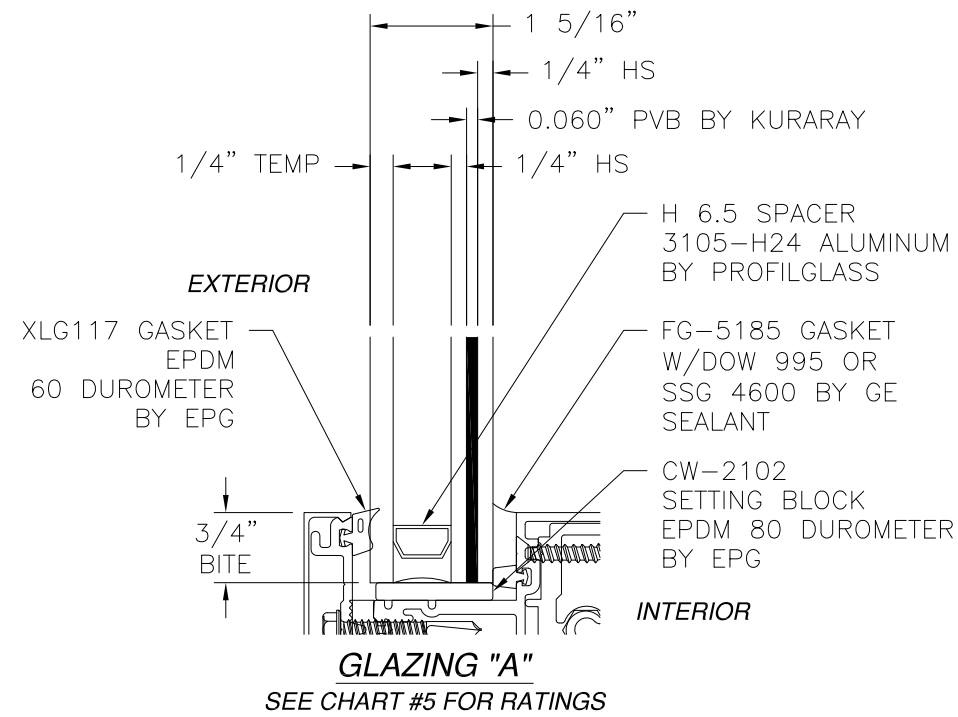

REVISIONS			
REV	DESCRIPTION	DATE	APPROVED

**Chart #5**  
Design pressure per glass "A" and "B" (psf)

D.L.O. Height (in)	D.L.O. width (in)								
	21.5	27.5	33.5	39.5	45.5	51.5	57.5	63.5	69.5
36.0	100.0	100.0	100.0	100.0	100.0	100.0	100.0	100.0	100.0
42.0	100.0	100.0	100.0	100.0	100.0	100.0	100.0	100.0	100.0
48.0	100.0	100.0	100.0	100.0	100.0	100.0	100.0	100.0	100.0
54.0	100.0	100.0	100.0	100.0	100.0	100.0	100.0	100.0	100.0
60.0	100.0	100.0	100.0	100.0	100.0	100.0	100.0	100.0	100.0
66.0	100.0	100.0	100.0	100.0	100.0	100.0	100.0	100.0	100.0
72.0	100.0	100.0	100.0	100.0	100.0	100.0	100.0	100.0	100.0
78.0	100.0	100.0	100.0	100.0	100.0	100.0	100.0	100.0	100.0
84.0	100.0	100.0	100.0	100.0	100.0	100.0	100.0	100.0	94.6
90.0	100.0	100.0	100.0	100.0	100.0	100.0	100.0	96.6	88.2
96.0	100.0	100.0	100.0	100.0	100.0	100.0	100.0	90.6	82.7

SIGNED: 12/15/2016

**US ALUMINUM**  
DIVISION OF C.R. LAURENCE CO., INC.  
2503 E. VERNON AVE., LOS ANGELES, CA 90058

STORM WALL XL HURRICANE RESISTANT  
CURTAIN WALL - WET GLAZED - SMI HVHZ  
GLAZING DETAILS

DRAWN: R.L.	DWG NO. 08-03021	REV -
SCALE NTS	DATE 12/07/16	SHEET 9 OF 24

L. ROBERTO LOMAS P.E.  
1432 WOODFORD RD LEWISVILLE, NC 27023  
434-688-0609 rllomas@rlomaspe.com

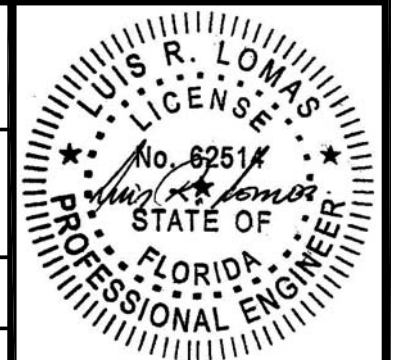

Luis R. Lomas P.E.  
FL No.: 62514

REVISIONS			
REV	DESCRIPTION	DATE	APPROVED

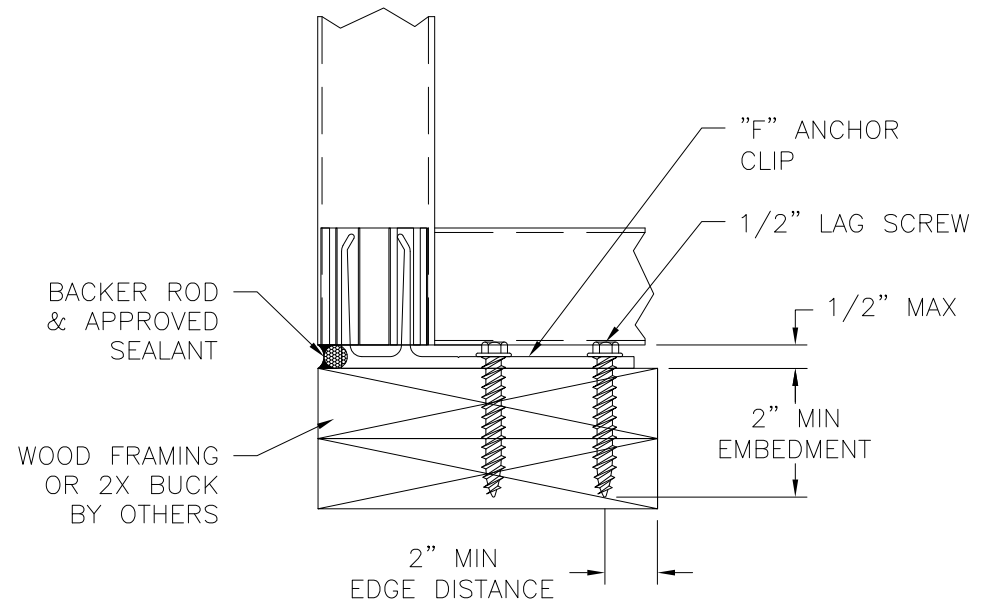
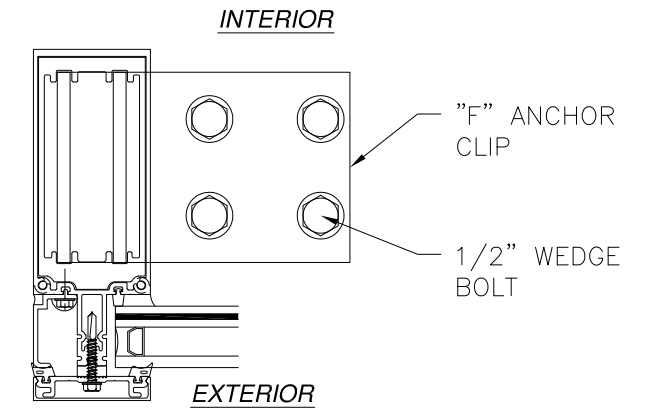
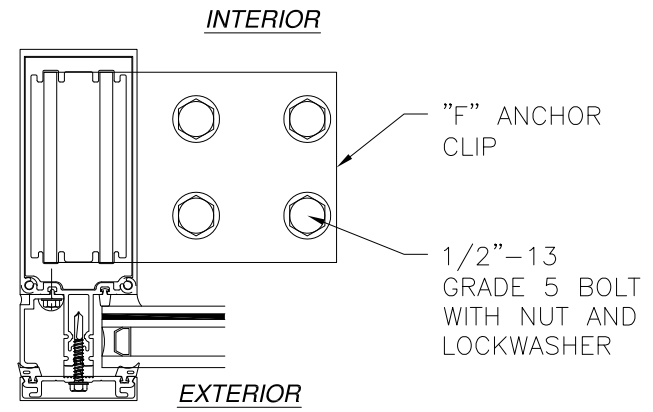
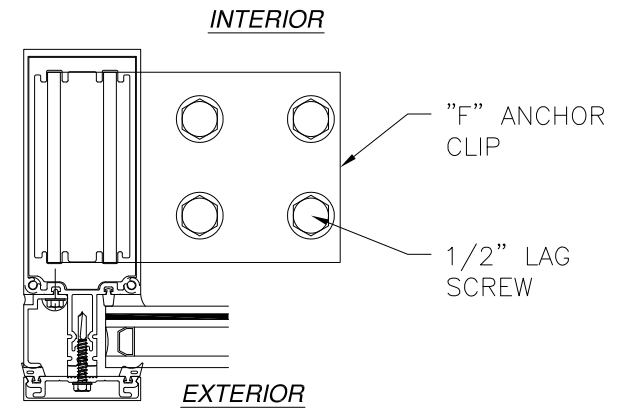

**JAMB INSTALLATION DETAIL**  
**WITH "F" ANCHOR CLIP**  
 WOOD FRAMING OR 2X BUCK INSTALLATION  
 SILL SHOWN, HEAD SIMILAR  
 SEE CHART #7 FOR RATINGS

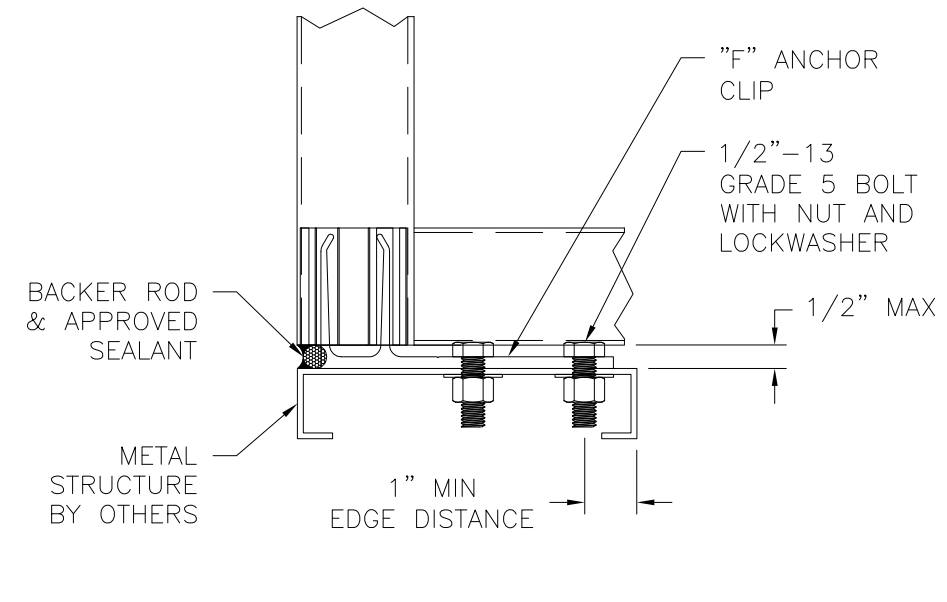

**JAMB INSTALLATION DETAIL**  
**WITH "F" ANCHOR CLIP**  
 METAL STRUCTURE INSTALLATION  
 SILL SHOWN, HEAD SIMILAR  
 SEE CHART #8 FOR RATINGS

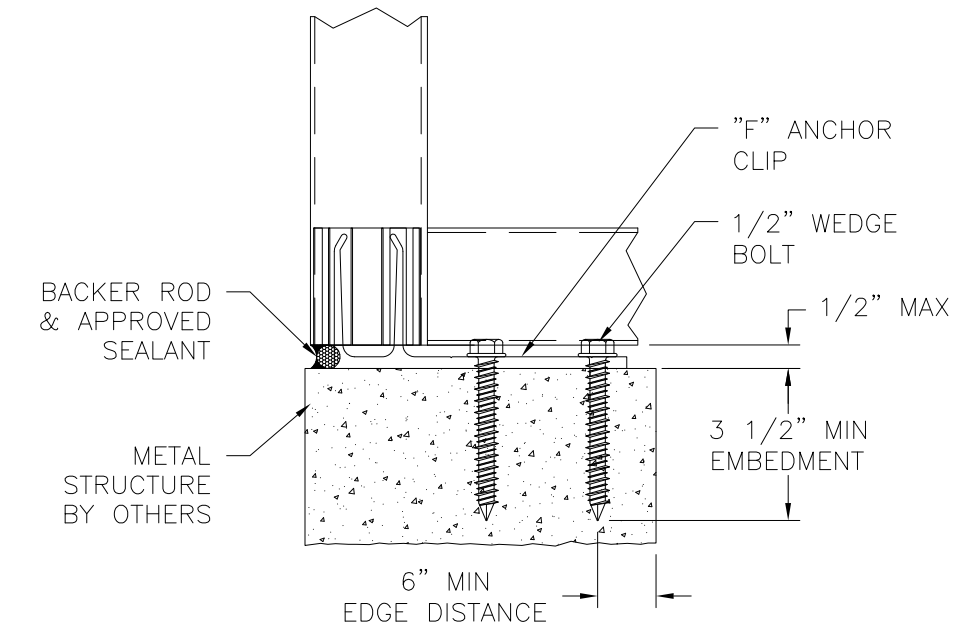

**JAMB INSTALLATION DETAIL**  
**WITH "F" ANCHOR CLIP**  
 CONCRETE INSTALLATION  
 SILL SHOWN, HEAD SIMILAR  
 SEE CHART #9 FOR RATINGS

- NOTES:
1. INTERIOR AND EXTERIOR FINISHES, BY OTHERS, NOT SHOWN FOR CLARITY.
  2. PERIMETER AND JOINT SEALANT BY OTHERS TO BE DESIGNED IN ACCORDANCE WITH ASTM E2112

SIGNED: 12/15/2016

**US ALUMINUM**  
 DIVISION OF C.R. LAURENCE CO., INC.  
 2503 E. VERNON AVE., LOS ANGELES, CA 90058

STORM WALL XL HURRICANE RESISTANT  
 CURTAIN WALL - WET GLAZED - SMI HVHZ  
 INSTALLATION DETAILS

DRAWN: R.L.	DWG NO. 08-03021	REV -
SCALE NTS	DATE 12/07/16	SHEET 10 OF 24

L. ROBERTO LOMAS P.E.  
 1432 WOODFORD RD LEWISVILLE, NC 27023  
 434-688-0609 rllomas@rlomaspe.com

Luis R. Lomas P.E.  
 FL No.: 62514

REVISIONS			
REV	DESCRIPTION	DATE	APPROVED

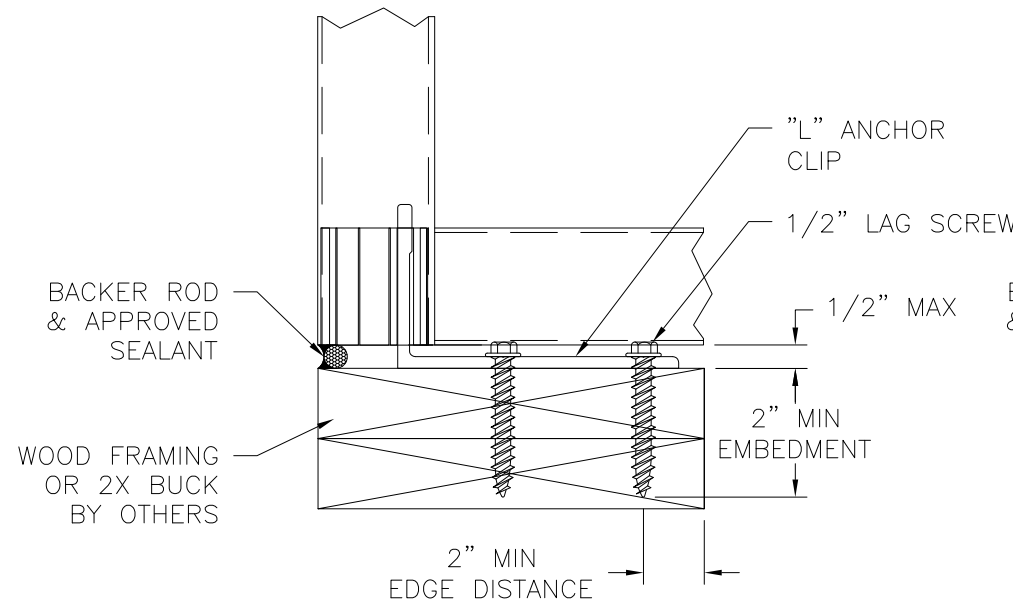
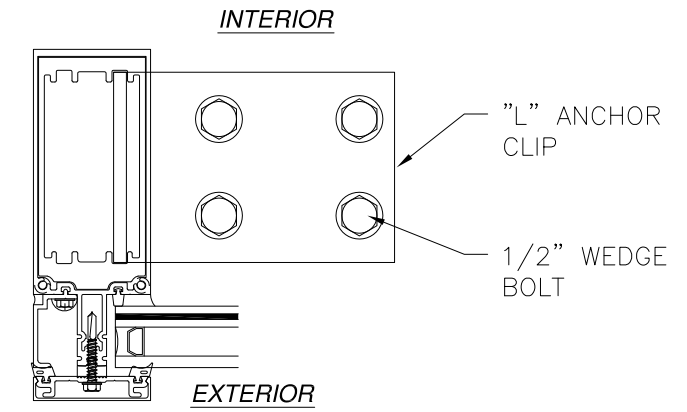
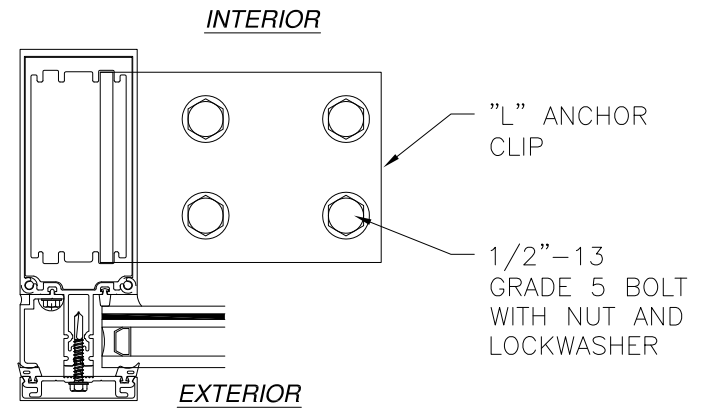
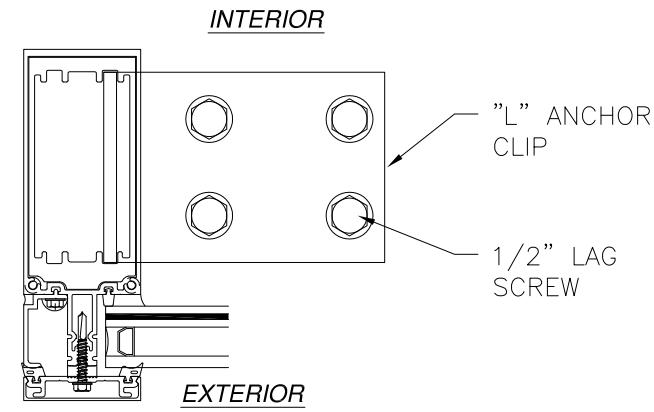

**JAMB INSTALLATION DETAIL  
WITH "L" ANCHOR CLIP  
WOOD FRAMING OR 2X BUCK INSTALLATION  
SILL SHOWN, HEAD SIMILAR  
SEE CHART #7 FOR RATINGS**

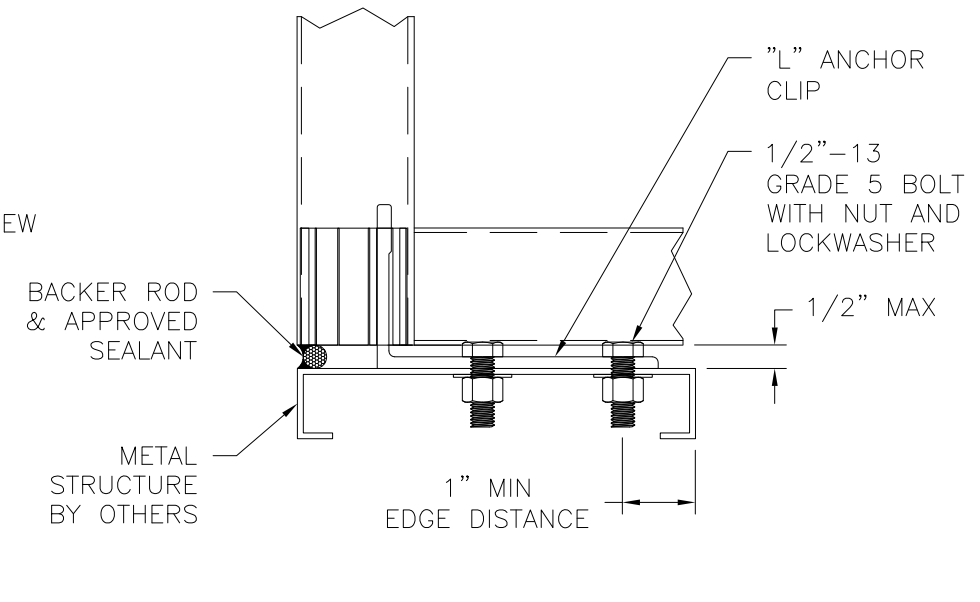

**JAMB INSTALLATION DETAIL  
WITH "L" ANCHOR CLIP  
METAL STRUCTURE INSTALLATION  
SILL SHOWN, HEAD SIMILAR  
SEE CHART #8 FOR RATINGS**

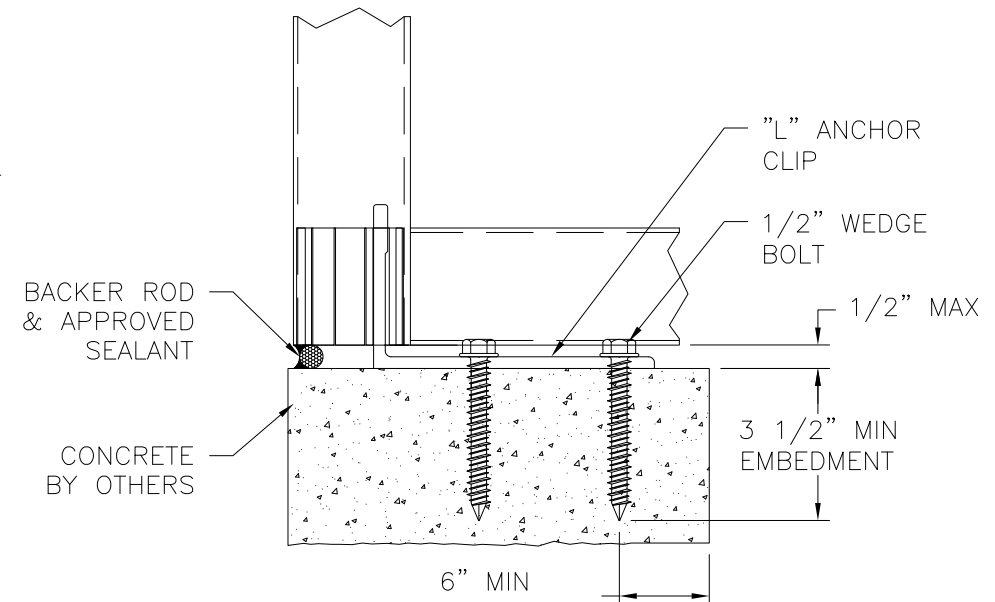

**JAMB INSTALLATION DETAIL  
WITH "L" ANCHOR CLIP  
CONCRETE INSTALLATION  
SILL SHOWN, HEAD SIMILAR  
SEE CHART #9 FOR RATINGS**

- NOTES:**
1. INTERIOR AND EXTERIOR FINISHES, BY OTHERS, NOT SHOWN FOR CLARITY.
  2. PERIMETER AND JOINT SEALANT BY OTHERS TO BE DESIGNED IN ACCORDANCE WITH ASTM E2112

SIGNED: 12/15/2016

**US ALUMINUM**  
DIVISION OF C.R. LAURENCE CO., INC.  
2503 E. VERNON AVE., LOS ANGELES, CA 90058

STORM WALL XL HURRICANE RESISTANT  
CURTAIN WALL - WET GLAZED - SMI HVHZ  
INSTALLATION DETAILS

DRAWN: R.L.	DWG NO. 08-03021	REV -
SCALE NTS	DATE 12/07/16	SHEET 11 OF 24

L. ROBERTO LOMAS P.E.  
1432 WOODFORD RD LEWISVILLE, NC 27023  
434-688-0609 rllomas@rlomaspe.com

Luis R. Lomas P.E.  
FL No.: 62514

REVISIONS			
REV	DESCRIPTION	DATE	APPROVED

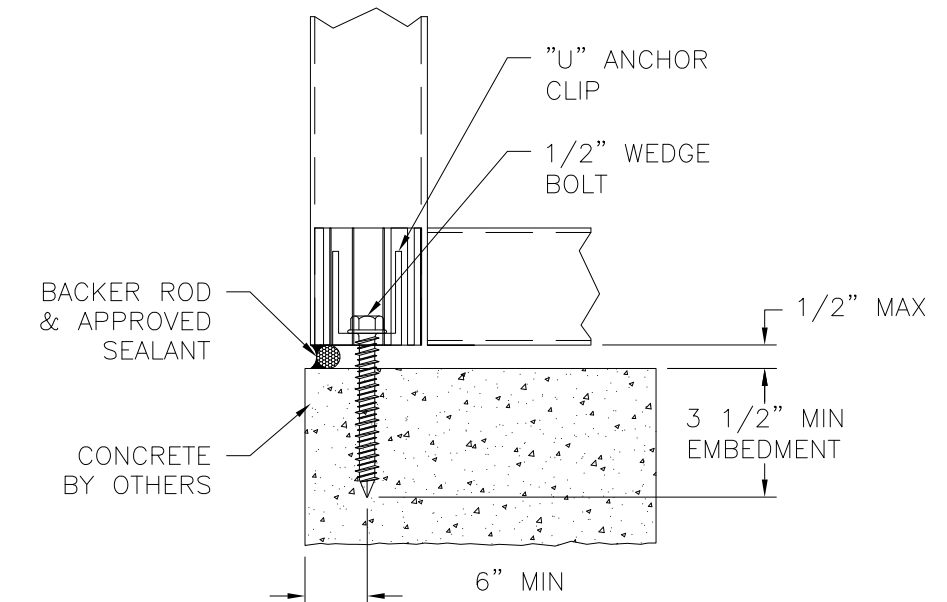
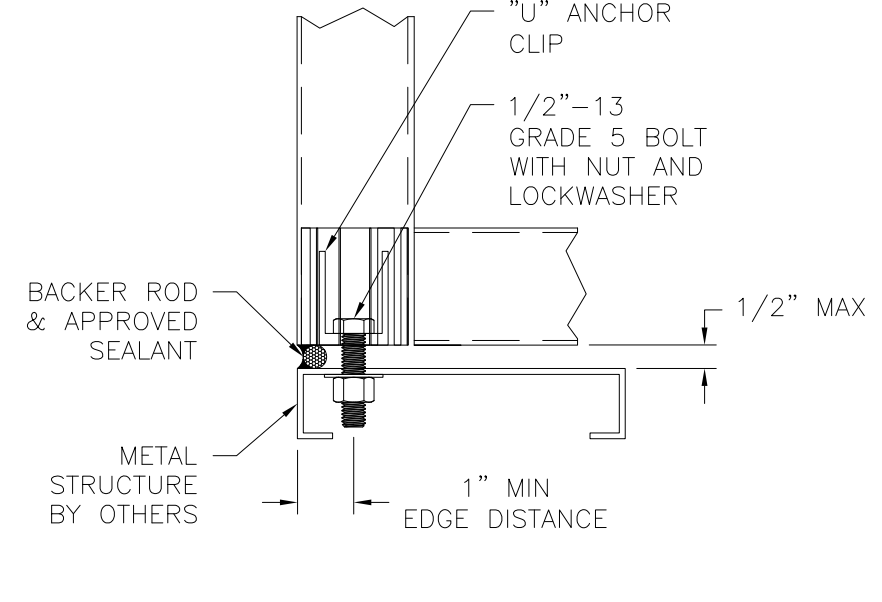
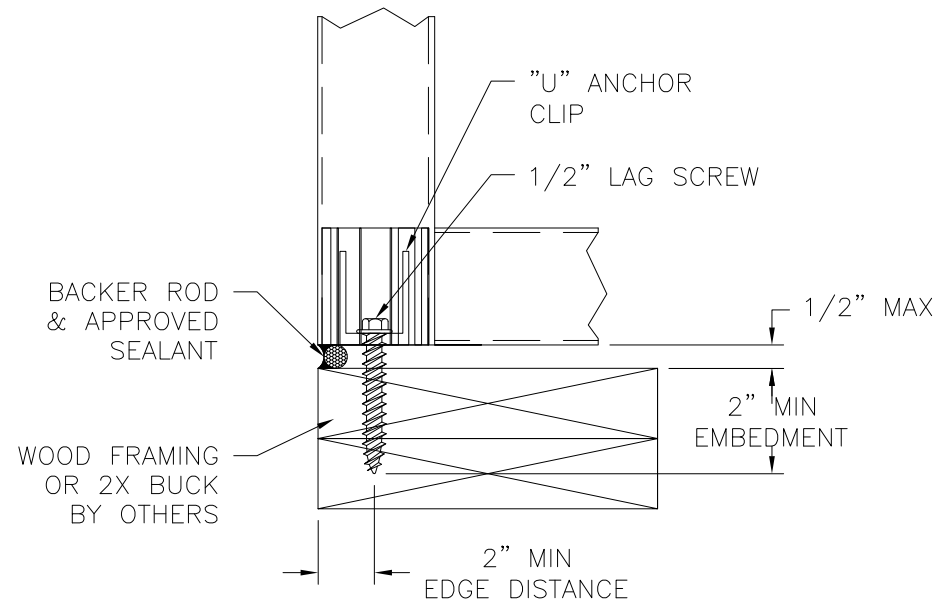
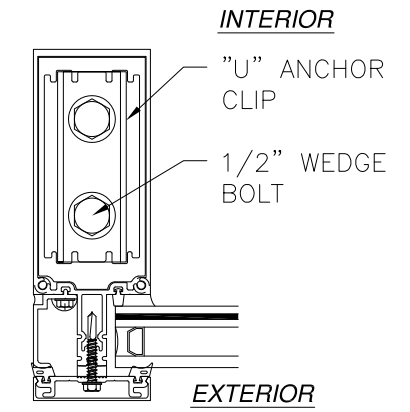
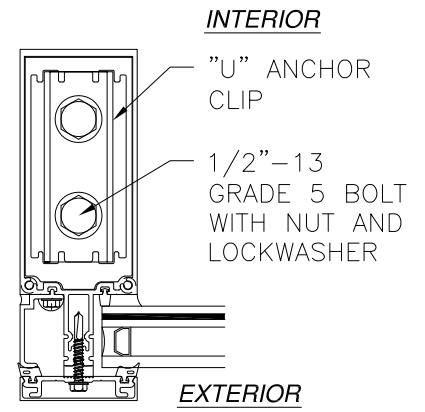
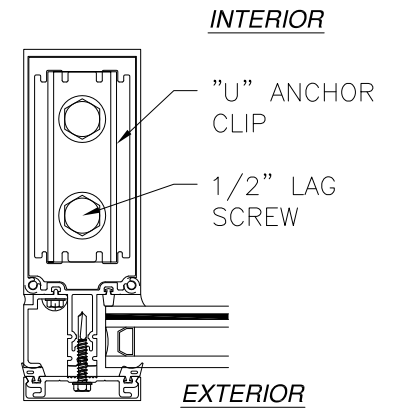

**JAMB INSTALLATION DETAIL  
WITH "U" ANCHOR CLIP**  
WOOD FRAMING OR 2X BUCK INSTALLATION  
SILL SHOWN, HEAD SIMILAR  
SEE CHART #6 FOR RATINGS

**JAMB INSTALLATION DETAIL  
WITH "U" ANCHOR CLIP**  
METAL STRUCTURE INSTALLATION  
SILL SHOWN, HEAD SIMILAR  
SEE CHART #8 FOR RATINGS

**JAMB INSTALLATION DETAIL  
WITH "U" ANCHOR CLIP**  
CONCRETE INSTALLATION  
SILL SHOWN, HEAD SIMILAR  
SEE CHART #9 FOR RATINGS

- NOTES:
1. INTERIOR AND EXTERIOR FINISHES, BY OTHERS, NOT SHOWN FOR CLARITY.
  2. PERIMETER AND JOINT SEALANT BY OTHERS TO BE DESIGNED IN ACCORDANCE WITH ASTM E2112

SIGNED: 12/15/2016

**US ALUMINUM**  
DIVISION OF C.R. LAURENCE CO., INC.  
2503 E. VERNON AVE., LOS ANGELES, CA 90058

STORM WALL XL HURRICANE RESISTANT  
CURTAIN WALL - WET GLAZED - SMI HVHZ  
INSTALLATION DETAILS

DRAWN: R.L.	DWG NO. 08-03021	REV -
SCALE NTS	DATE 12/07/16	SHEET 12 OF 24

L. ROBERTO LOMAS P.E.  
1432 WOODFORD RD LEWISVILLE, NC 27023  
434-688-0609 rllomas@rlomaspe.com

Luis R. Lomas P.E.  
FL No.: 62514

REVISIONS			
REV	DESCRIPTION	DATE	APPROVED

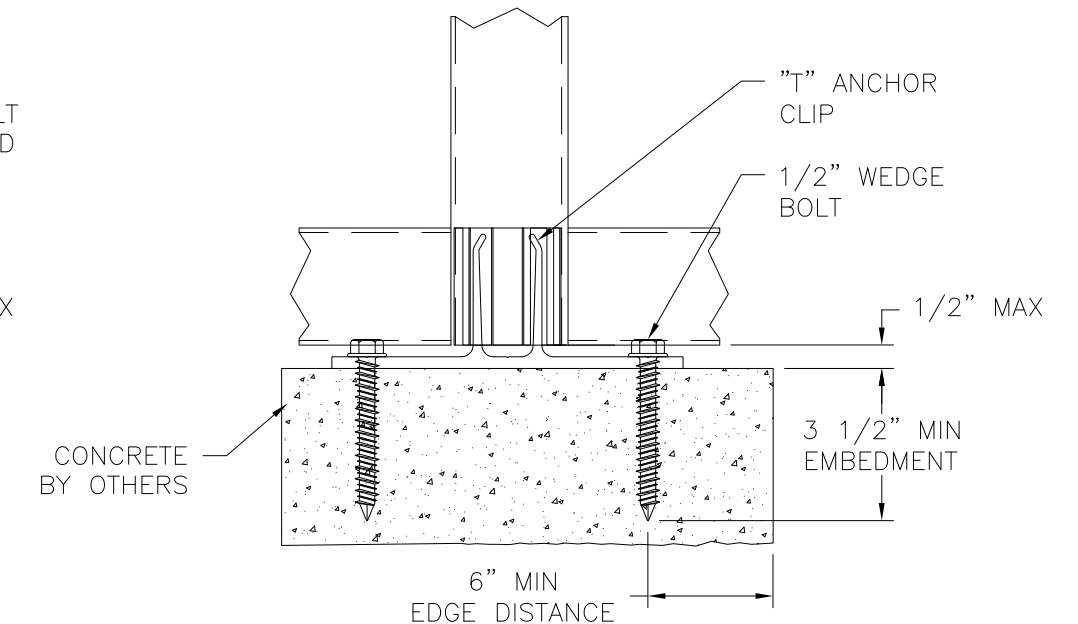
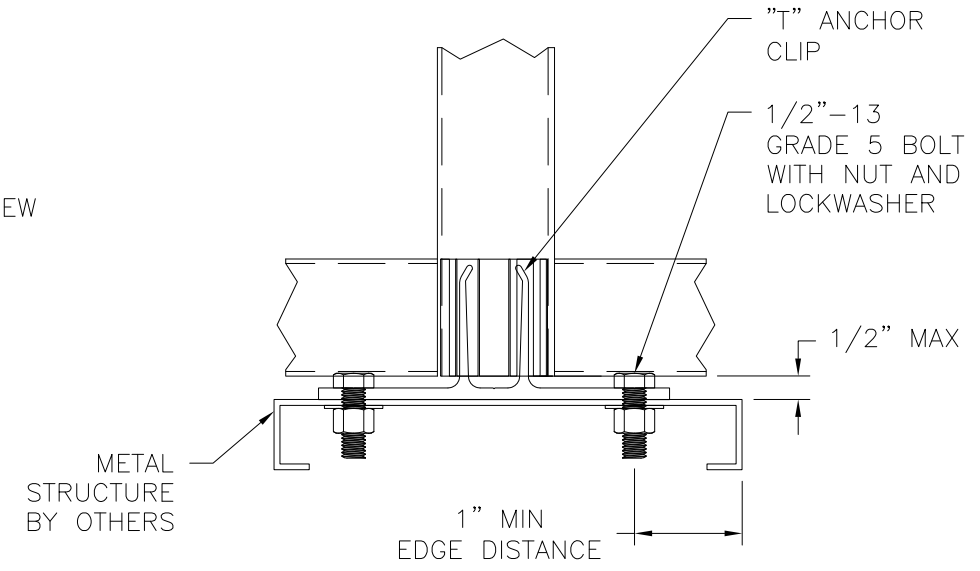
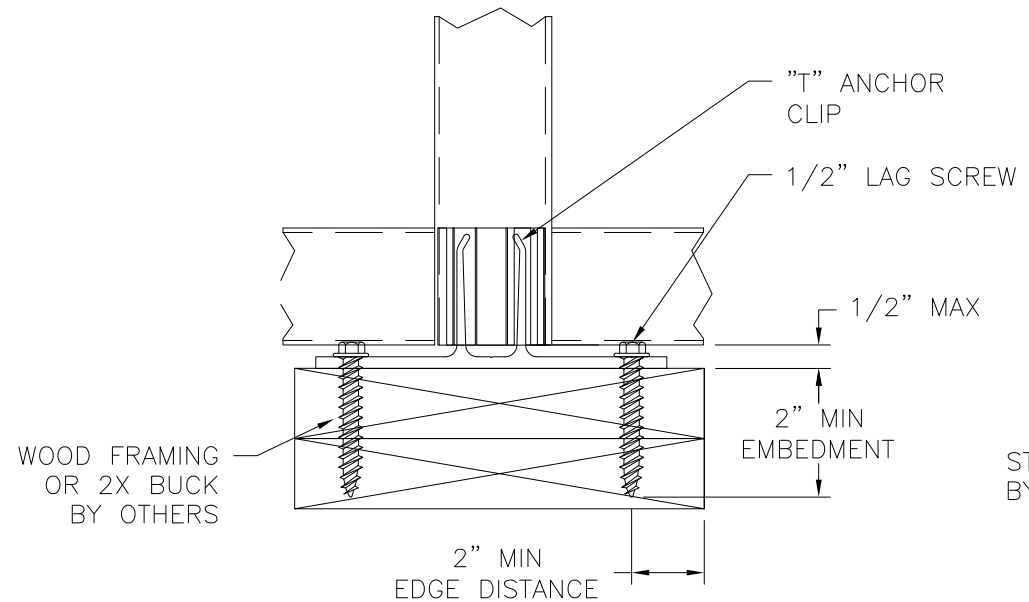
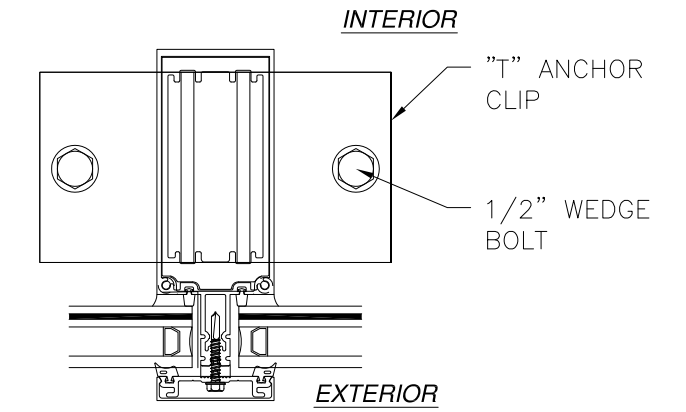
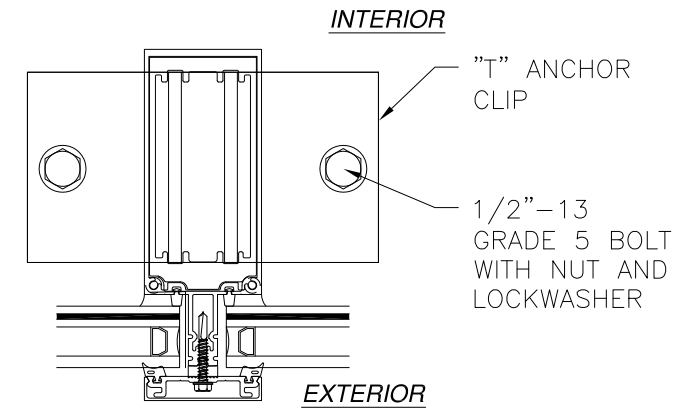
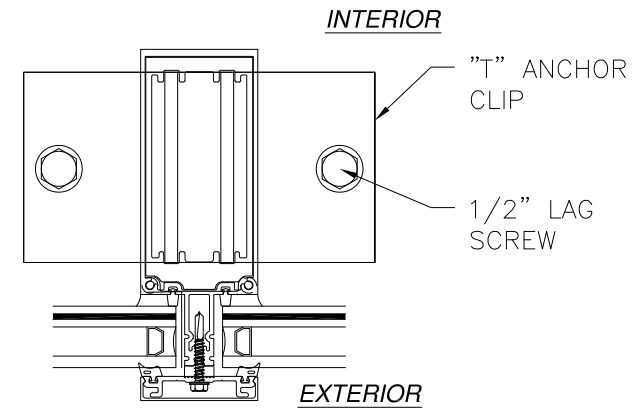

**MULLION INSTALLATION DETAIL  
WITH "T" ANCHOR CLIP  
WOOD FRAMING OR 2X BUCK INSTALLATION  
SILL SHOWN, HEAD SIMILAR  
SEE CHART #10 FOR RATINGS**

**MULLION INSTALLATION DETAIL  
WITH "T" ANCHOR CLIP  
METAL STRUCTURE INSTALLATION  
SILL SHOWN, HEAD SIMILAR  
SEE CHART #12 FOR RATINGS**

**MULLION INSTALLATION DETAIL  
WITH "T" ANCHOR CLIP  
CONCRETE INSTALLATION  
SILL SHOWN, HEAD SIMILAR  
SEE CHART #13 FOR RATINGS**

- NOTES:**
1. INTERIOR AND EXTERIOR FINISHES, BY OTHERS, NOT SHOWN FOR CLARITY.
  2. PERIMETER AND JOINT SEALANT BY OTHERS TO BE DESIGNED IN ACCORDANCE WITH ASTM E2112

SIGNED: 12/15/2016

**US ALUMINUM**  
DIVISION OF C.R. LAURENCE CO., INC.  
2503 E. VERNON AVE., LOS ANGELES, CA 90058

STORM WALL XL HURRICANE RESISTANT  
CURTAIN WALL - WET GLAZED - SMI HVHZ  
INSTALLATION DETAILS

DRAWN: R.L.	DWG NO. 08-03021	REV -
SCALE NTS	DATE 12/07/16	SHEET 13 OF 24

L. ROBERTO LOMAS P.E.  
1432 WOODFORD RD LEWISVILLE, NC 27023  
434-688-0609 rllomas@rlomaspe.com

Luis R. Lomas P.E.  
FL No.: 62514

REVISIONS			
REV	DESCRIPTION	DATE	APPROVED

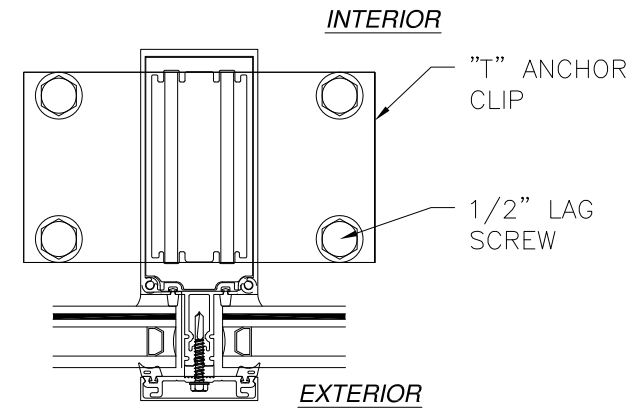

**MULLION INSTALLATION DETAIL  
WITH "T" ANCHOR CLIP  
WOOD FRAMING OR 2X BUCK INSTALLATION  
SILL SHOWN, HEAD SIMILAR  
SEE CHART #11 FOR RATINGS**

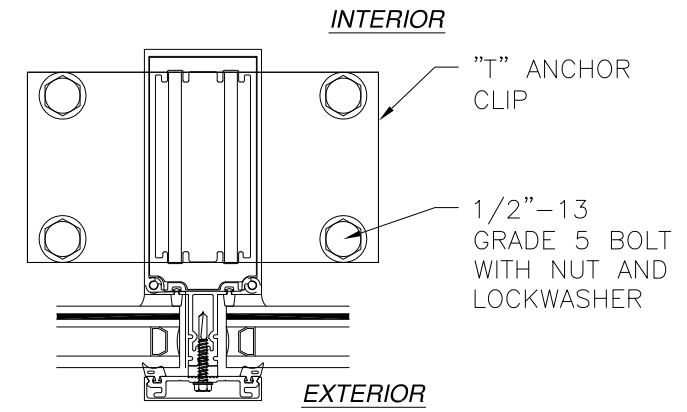

**MULLION INSTALLATION DETAIL  
WITH "T" ANCHOR CLIP  
METAL STRUCTURE INSTALLATION  
SILL SHOWN, HEAD SIMILAR  
SEE CHART #12 FOR RATINGS**

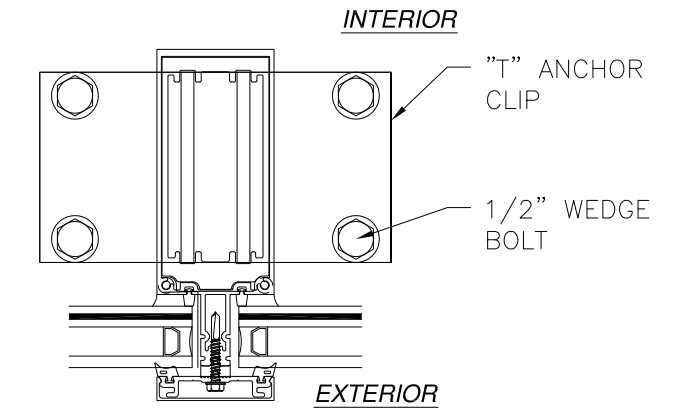

**MULLION INSTALLATION DETAIL  
WITH "T" ANCHOR CLIP  
CONCRETE INSTALLATION  
SILL SHOWN, HEAD SIMILAR  
SEE CHART #14 FOR RATINGS**

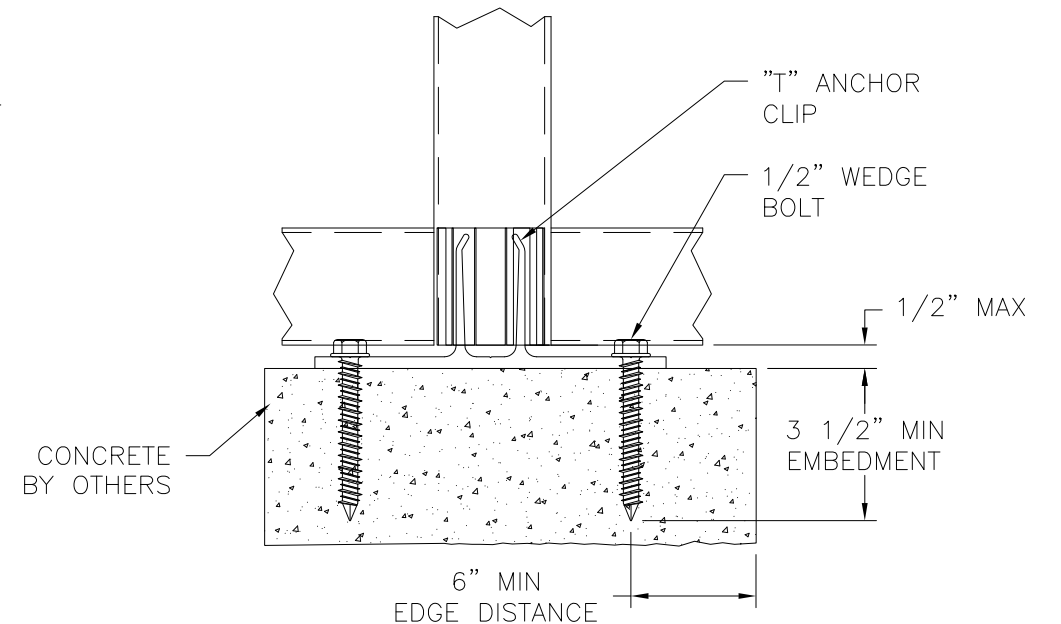
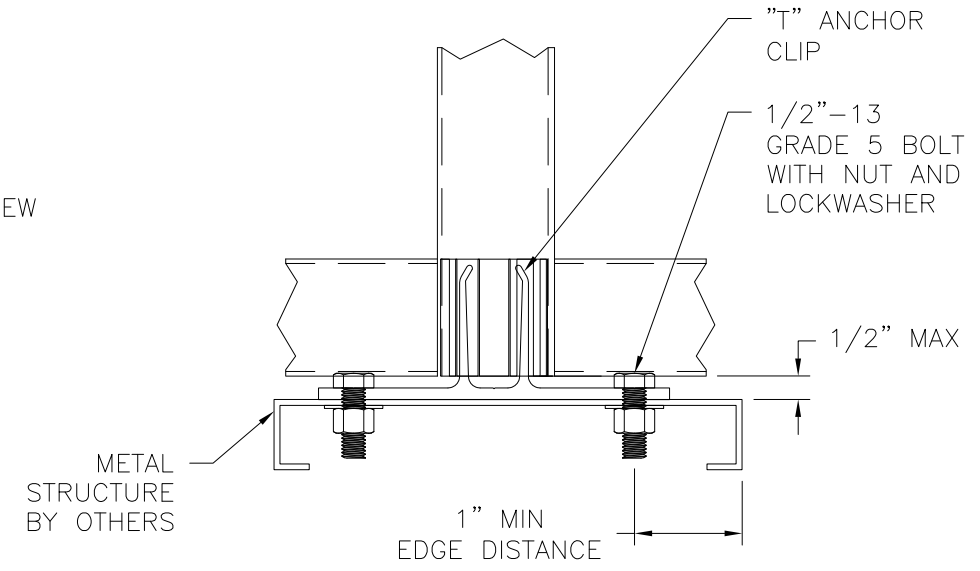
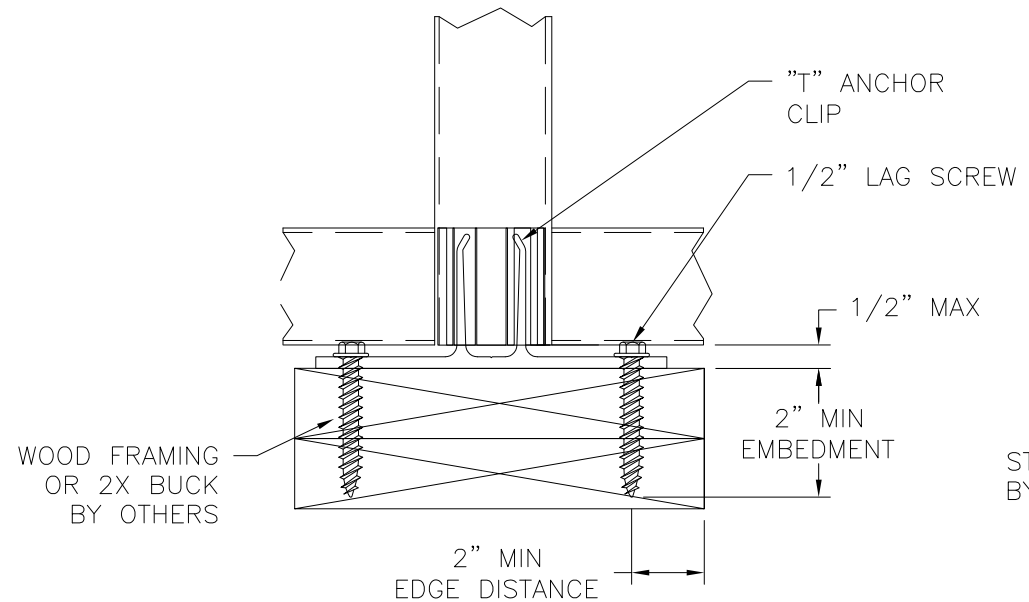

- NOTES:**
1. INTERIOR AND EXTERIOR FINISHES, BY OTHERS, NOT SHOWN FOR CLARITY.
  2. PERIMETER AND JOINT SEALANT BY OTHERS TO BE DESIGNED IN ACCORDANCE WITH ASTM E2112

SIGNED: 12/15/2016

**US ALUMINUM**  
DIVISION OF C.R. LAURENCE CO., INC.  
2503 E. VERNON AVE., LOS ANGELES, CA 90058

STORM WALL XL HURRICANE RESISTANT  
CURTAIN WALL - WET GLAZED - SMI HVHZ  
INSTALLATION DETAILS

DRAWN: R.L.	DWG NO. 08-03021	REV -
SCALE NTS	DATE 12/07/16	SHEET 14 OF 24

L. ROBERTO LOMAS P.E.  
1432 WOODFORD RD LEWISVILLE, NC 27023  
434-688-0609 rllomas@rlomaspe.com

Luis R. Lomas P.E.  
FL No.: 62514

REVISIONS			
REV	DESCRIPTION	DATE	APPROVED

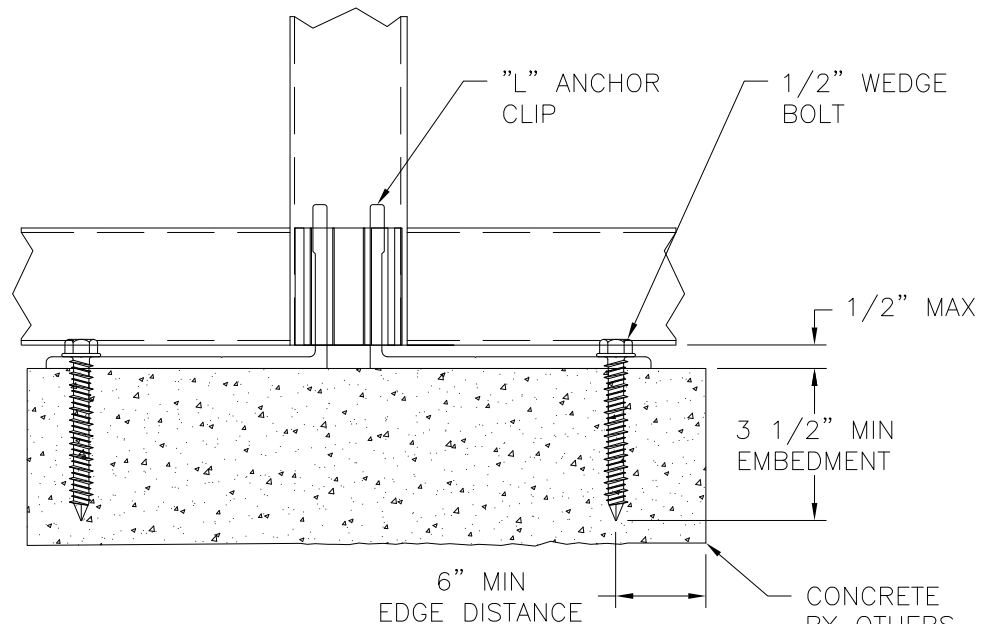
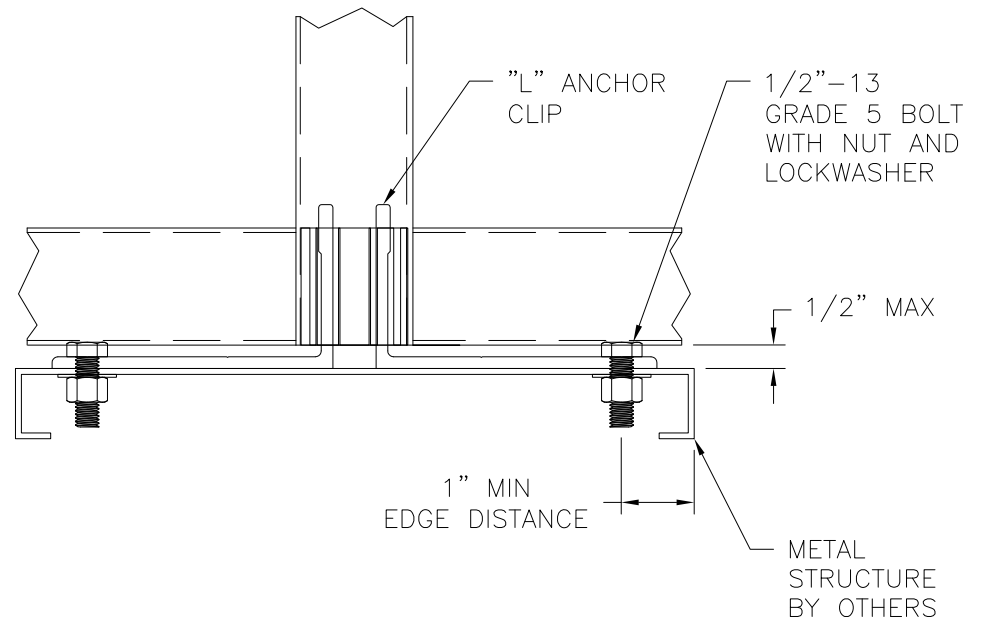
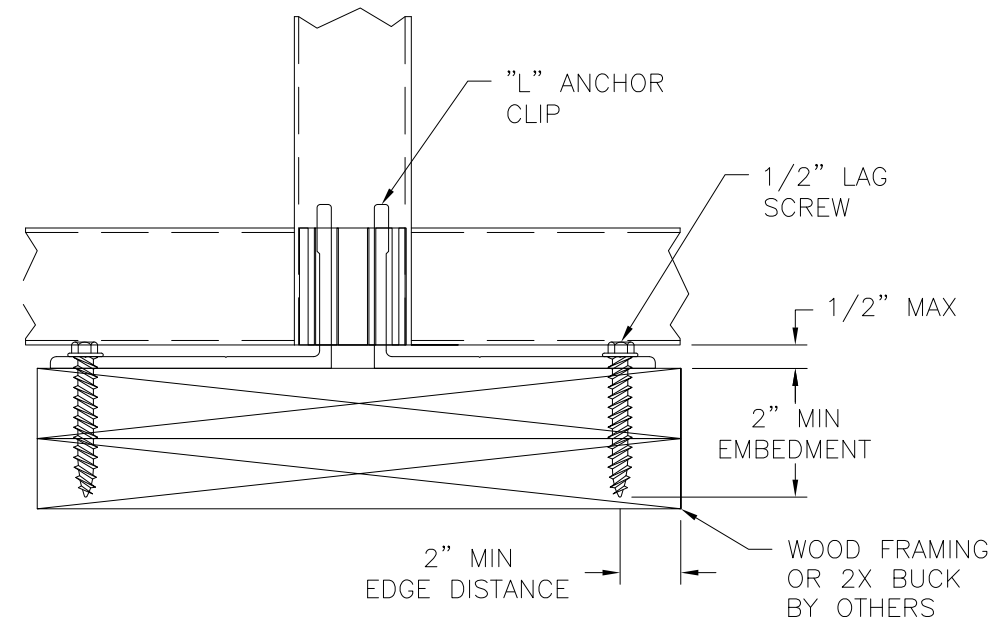
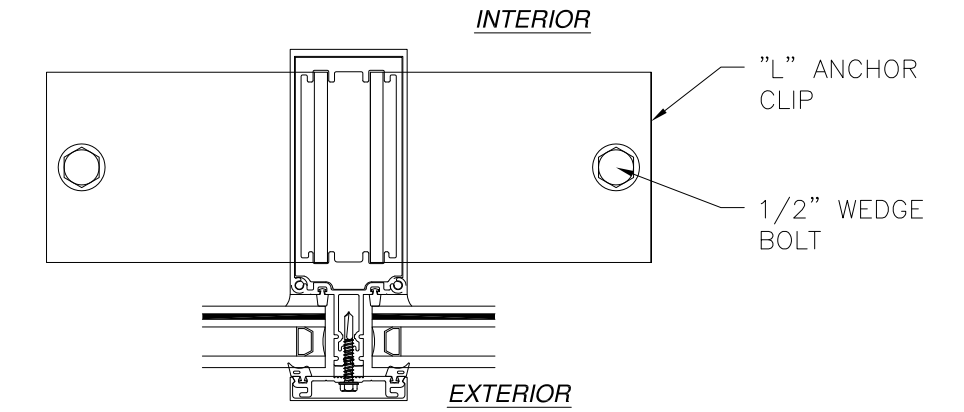
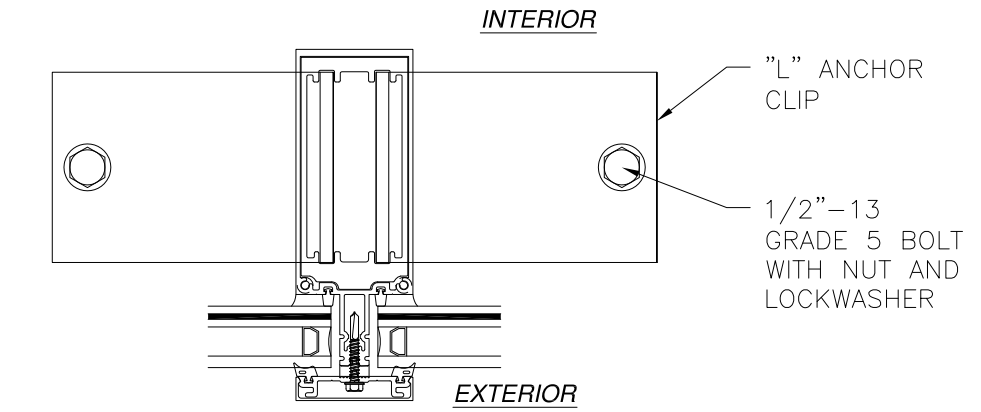
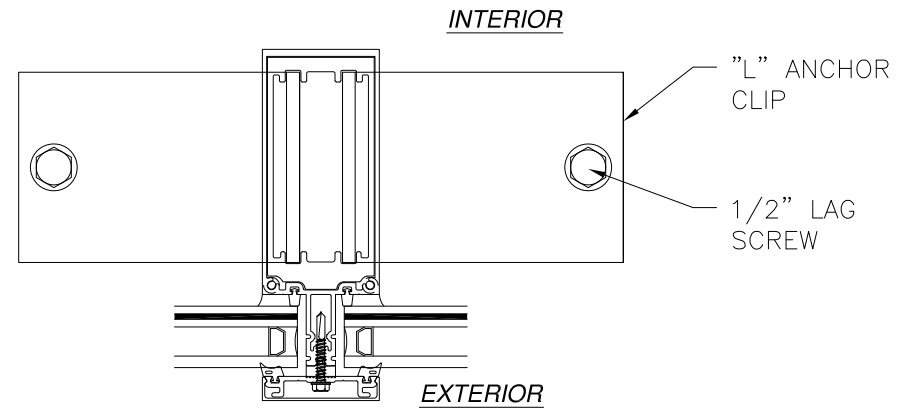

**MULLION INSTALLATION DETAIL  
WITH "L" ANCHOR CLIP**  
WOOD FRAMING OR 2X BUCK INSTALLATION  
SILL SHOWN, HEAD SIMILAR  
SEE CHART #10 FOR RATINGS

**MULLION INSTALLATION DETAIL  
WITH "L" ANCHOR CLIP**  
METAL STRUCTURE INSTALLATION  
SILL SHOWN, HEAD SIMILAR  
SEE CHART #12 FOR RATINGS

**MULLION INSTALLATION DETAIL  
WITH "L" ANCHOR CLIP**  
CONCRETE INSTALLATION  
SILL SHOWN, HEAD SIMILAR  
SEE CHART #13 FOR RATINGS

- NOTES:
1. INTERIOR AND EXTERIOR FINISHES, BY OTHERS, NOT SHOWN FOR CLARITY.
  2. PERIMETER AND JOINT SEALANT BY OTHERS TO BE DESIGNED IN ACCORDANCE WITH ASTM E2112

SIGNED: 12/15/2016

**US ALUMINUM**  
DIVISION OF C.R. LAURENCE CO., INC.  
2503 E. VERNON AVE., LOS ANGELES, CA 90058

STORM WALL XL HURRICANE RESISTANT  
CURTAIN WALL – WET GLAZED – SMI HVHZ  
INSTALLATION DETAILS

DRAWN: R.L.	DWG NO. 08-03021	REV -
SCALE NTS	DATE 12/07/16	SHEET 15 OF 24

L. ROBERTO LOMAS P.E.  
1432 WOODFORD RD LEWISVILLE, NC 27023  
434-688-0609 rllomas@rlomaspe.com

Luis R. Lomas P.E.  
FL No.: 62514

REVISIONS			
REV	DESCRIPTION	DATE	APPROVED

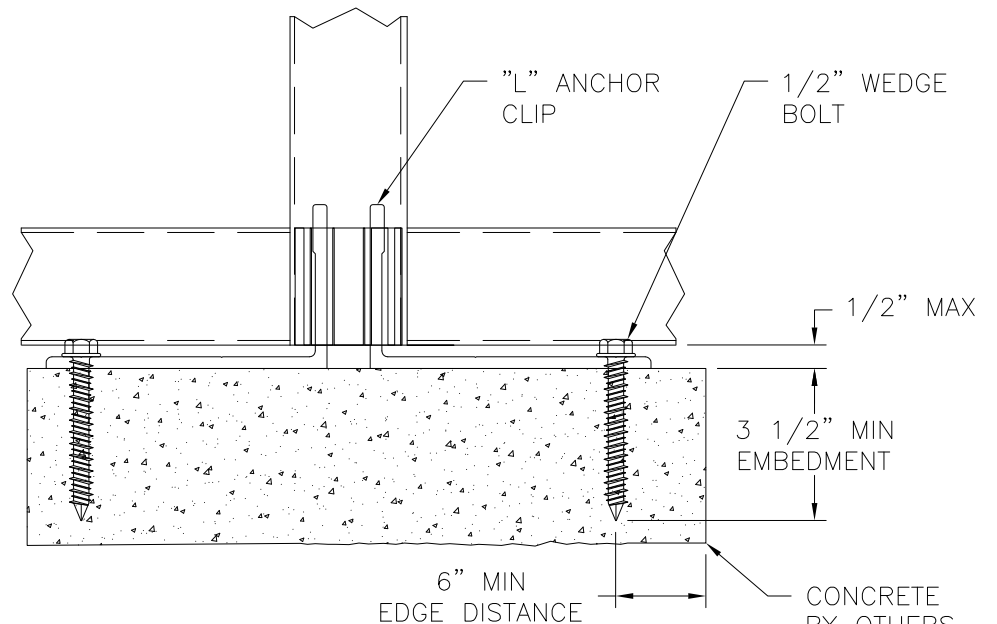
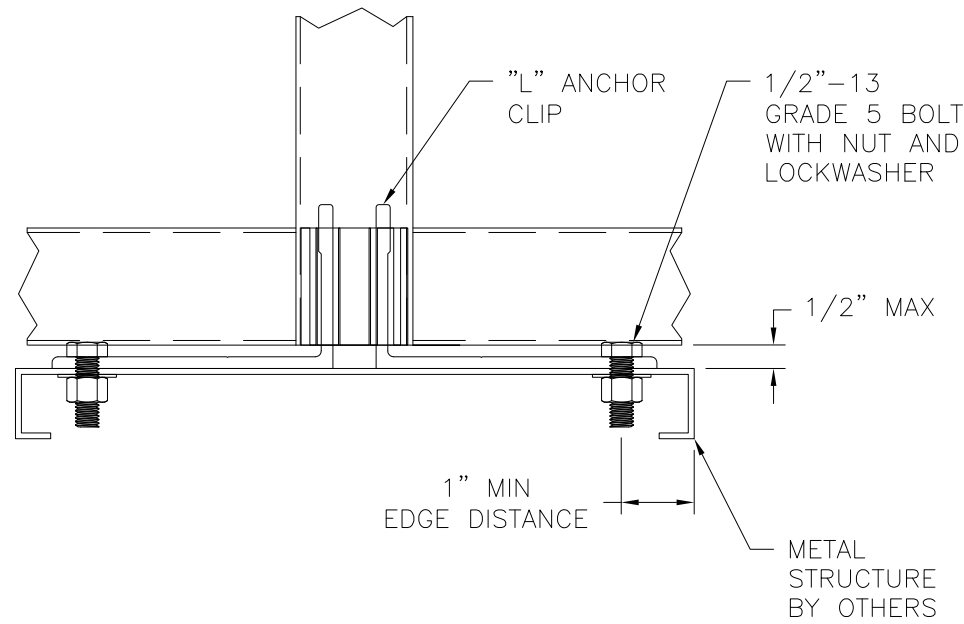
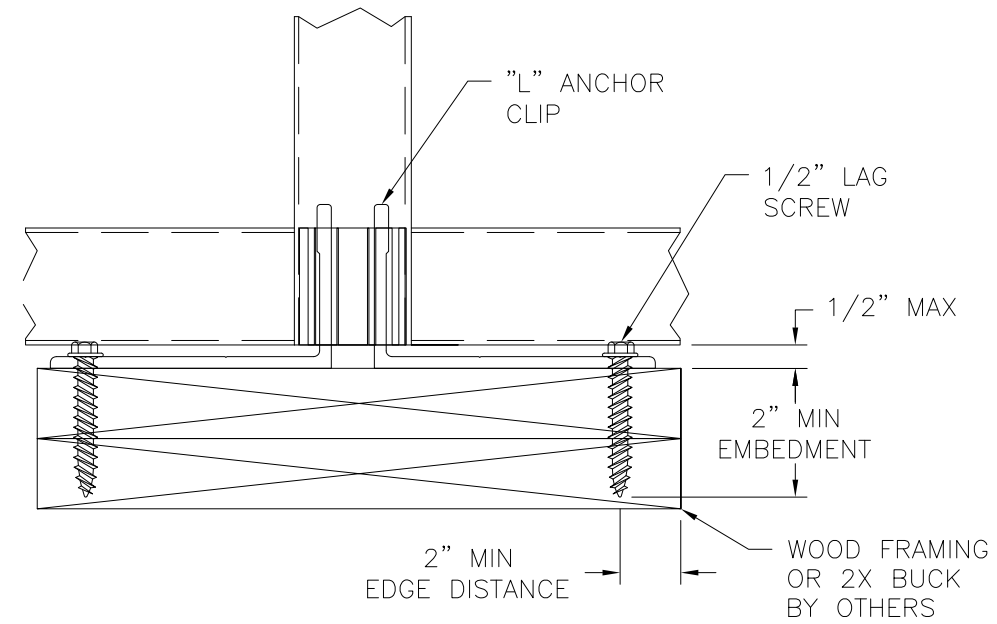
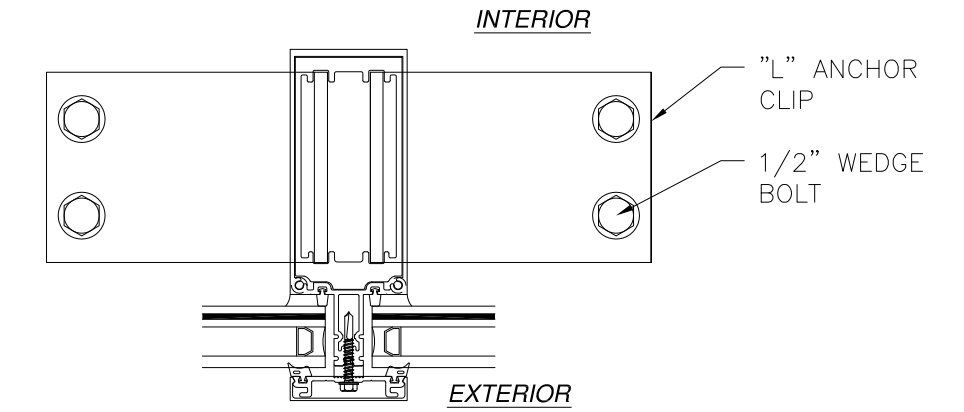
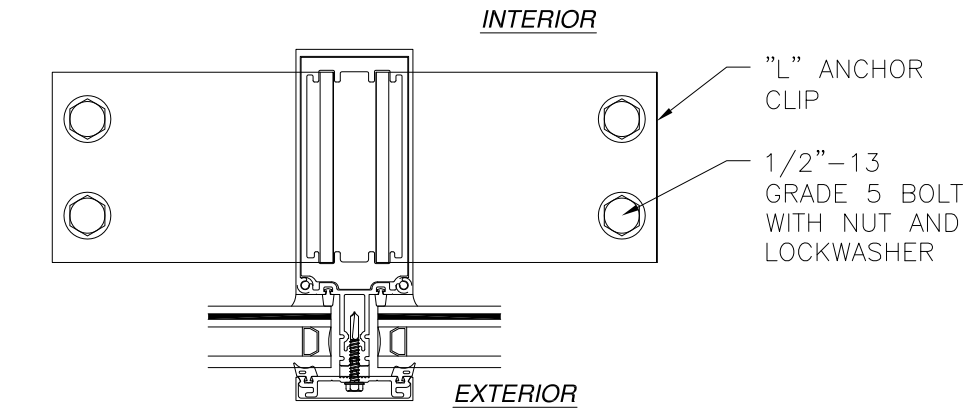
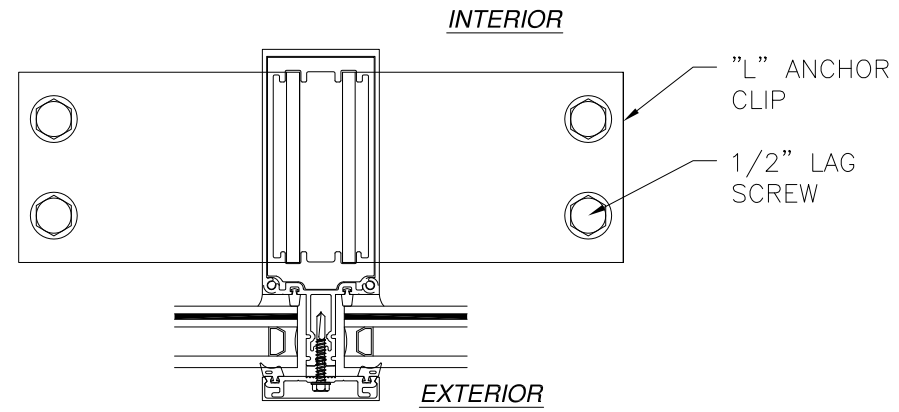

**MULLION INSTALLATION DETAIL  
WITH "L" ANCHOR CLIP**  
WOOD FRAMING OR 2X BUCK INSTALLATION  
SILL SHOWN, HEAD SIMILAR  
SEE CHART #11 FOR RATINGS

**MULLION INSTALLATION DETAIL  
WITH "L" ANCHOR CLIP**  
METAL STRUCTURE INSTALLATION  
SILL SHOWN, HEAD SIMILAR  
SEE CHART #12 FOR RATINGS

**MULLION INSTALLATION DETAIL  
WITH "L" ANCHOR CLIP**  
CONCRETE INSTALLATION  
SILL SHOWN, HEAD SIMILAR  
SEE CHART #14 FOR RATINGS

- NOTES:
1. INTERIOR AND EXTERIOR FINISHES, BY OTHERS, NOT SHOWN FOR CLARITY.
  2. PERIMETER AND JOINT SEALANT BY OTHERS TO BE DESIGNED IN ACCORDANCE WITH ASTM E2112

SIGNED: 12/15/2016

**US ALUMINUM**  
DIVISION OF C.R. LAURENCE CO., INC.  
2503 E. VERNON AVE., LOS ANGELES, CA 90058

STORM WALL XL HURRICANE RESISTANT  
CURTAIN WALL - WET GLAZED - SMI HVHZ  
INSTALLATION DETAILS

DRAWN: R.L.	DWG NO. 08-03021	REV -
SCALE NTS	DATE 12/07/16	SHEET 16 OF 24

L. ROBERTO LOMAS P.E.  
1432 WOODFORD RD LEWISVILLE, NC 27023  
434-688-0609 rllomas@rlomaspe.com

Luis R. Lomas P.E.  
FL No.: 62514



REVISIONS			
REV	DESCRIPTION	DATE	APPROVED

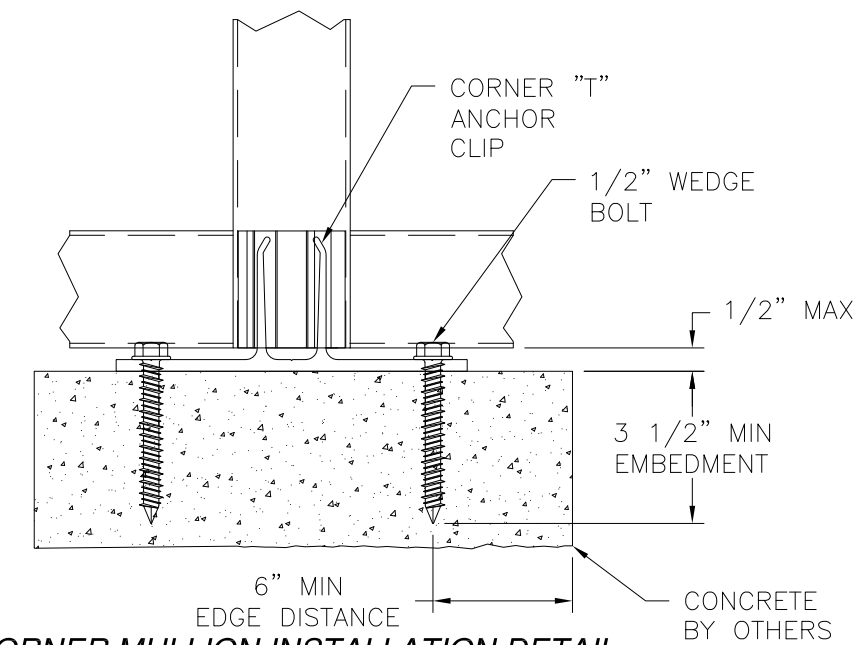
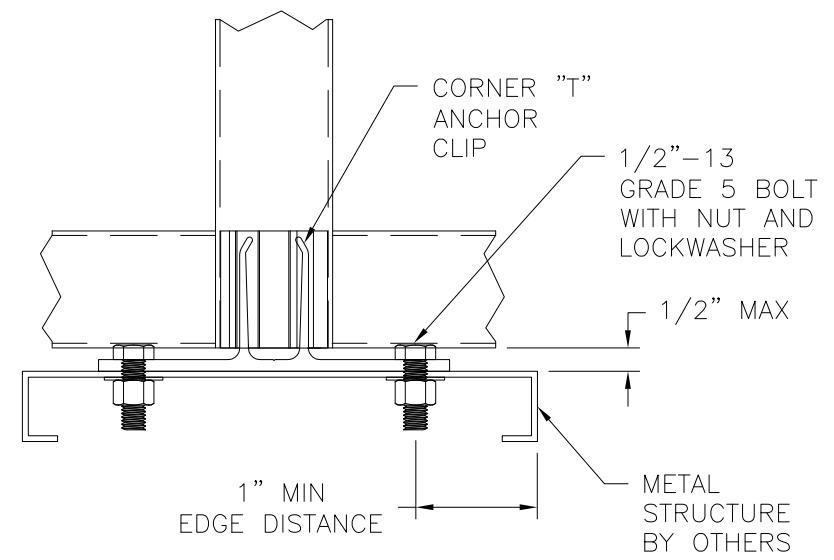
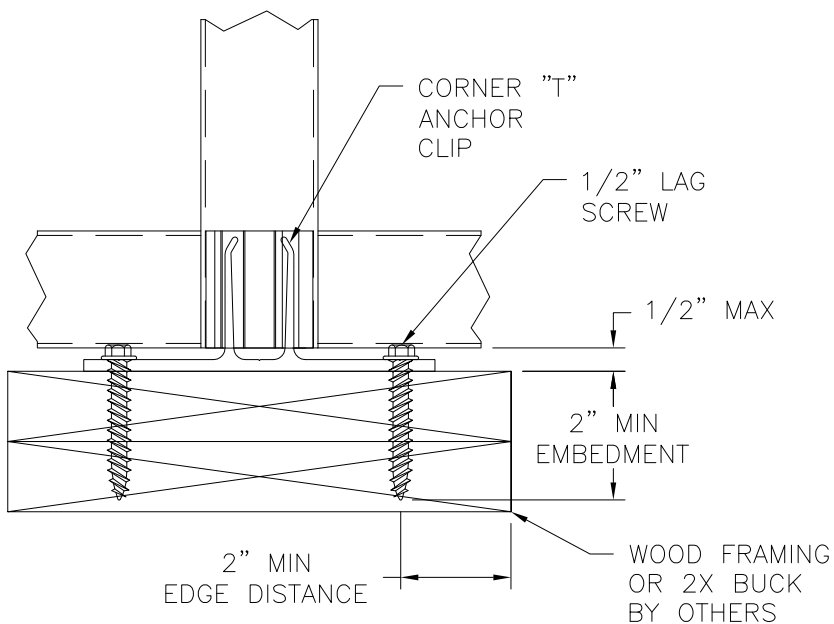
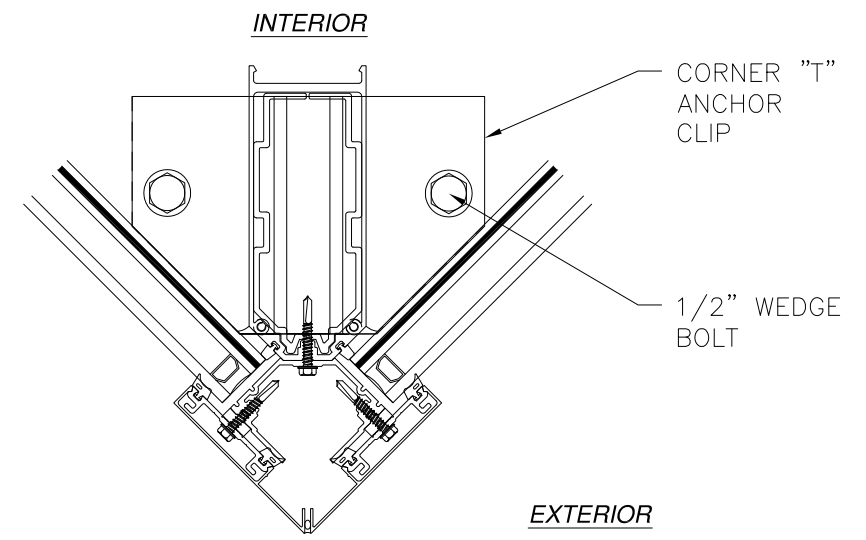
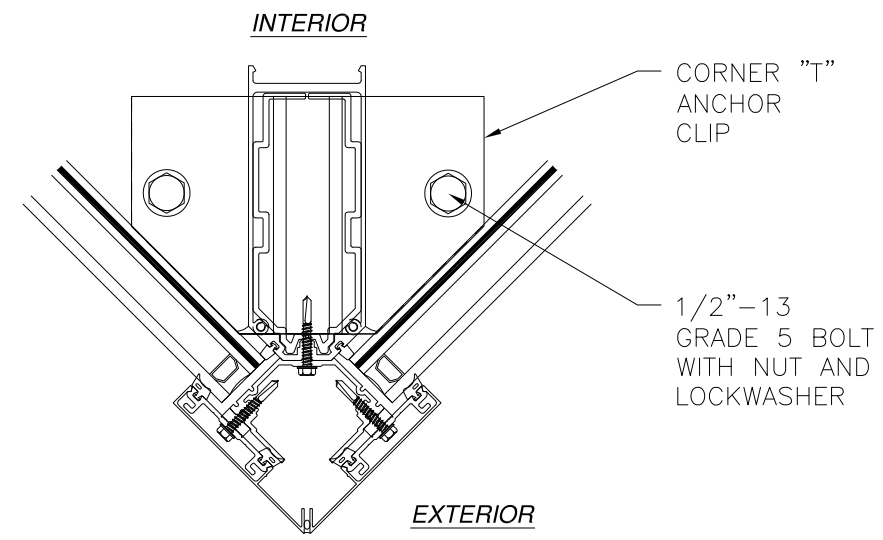
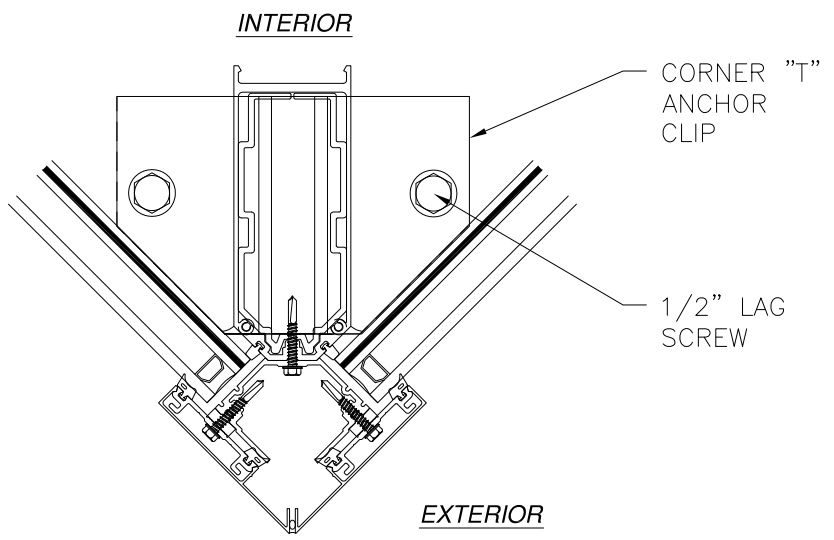

**CORNER MULLION INSTALLATION DETAIL WITH "T" ANCHOR CLIP**  
**WOOD FRAMING OR 2X BUCK INSTALLATION**  
 SILL SHOWN, HEAD SIMILAR  
 SEE CHART #10 FOR RATINGS

**CORNER MULLION INSTALLATION DETAIL WITH "T" ANCHOR CLIP**  
**METAL STRUCTURE INSTALLATION**  
 SILL SHOWN, HEAD SIMILAR  
 SEE CHART #12 FOR RATINGS

**CORNER MULLION INSTALLATION DETAIL WITH "T" ANCHOR CLIP**  
**CONCRETE INSTALLATION**  
 SILL SHOWN, HEAD SIMILAR  
 SEE CHART #13 FOR RATINGS

SIGNED: 12/15/2016

- NOTES:
1. INTERIOR AND EXTERIOR FINISHES, BY OTHERS, NOT SHOWN FOR CLARITY.
  2. PERIMETER AND JOINT SEALANT BY OTHERS TO BE DESIGNED IN ACCORDANCE WITH ASTM E2112

**US ALUMINUM**  
 DIVISION OF C.R. LAURENCE CO., INC.  
 2503 E. VERNON AVE., LOS ANGELES, CA 90058

STORM WALL XL HURRICANE RESISTANT  
 CURTAIN WALL - WET GLAZED - SMI HVHZ  
 INSTALLATION DETAILS

DRAWN: R.L.	DWG NO. 08-03021	REV -
SCALE NTS	DATE 12/07/16	SHEET 17 OF 24

L. ROBERTO LOMAS P.E.  
 1432 WOODFORD RD LEWISVILLE, NC 27023  
 434-688-0609 rllomas@rlomaspe.com

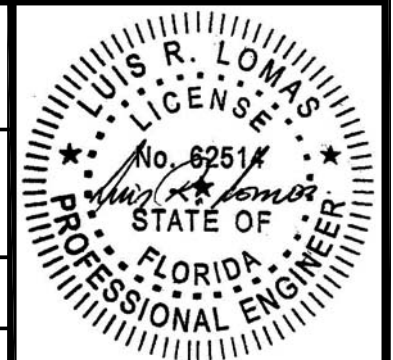

Luis R. Lomas P.E.  
 FL No.: 62514





REVISIONS			
REV	DESCRIPTION	DATE	APPROVED

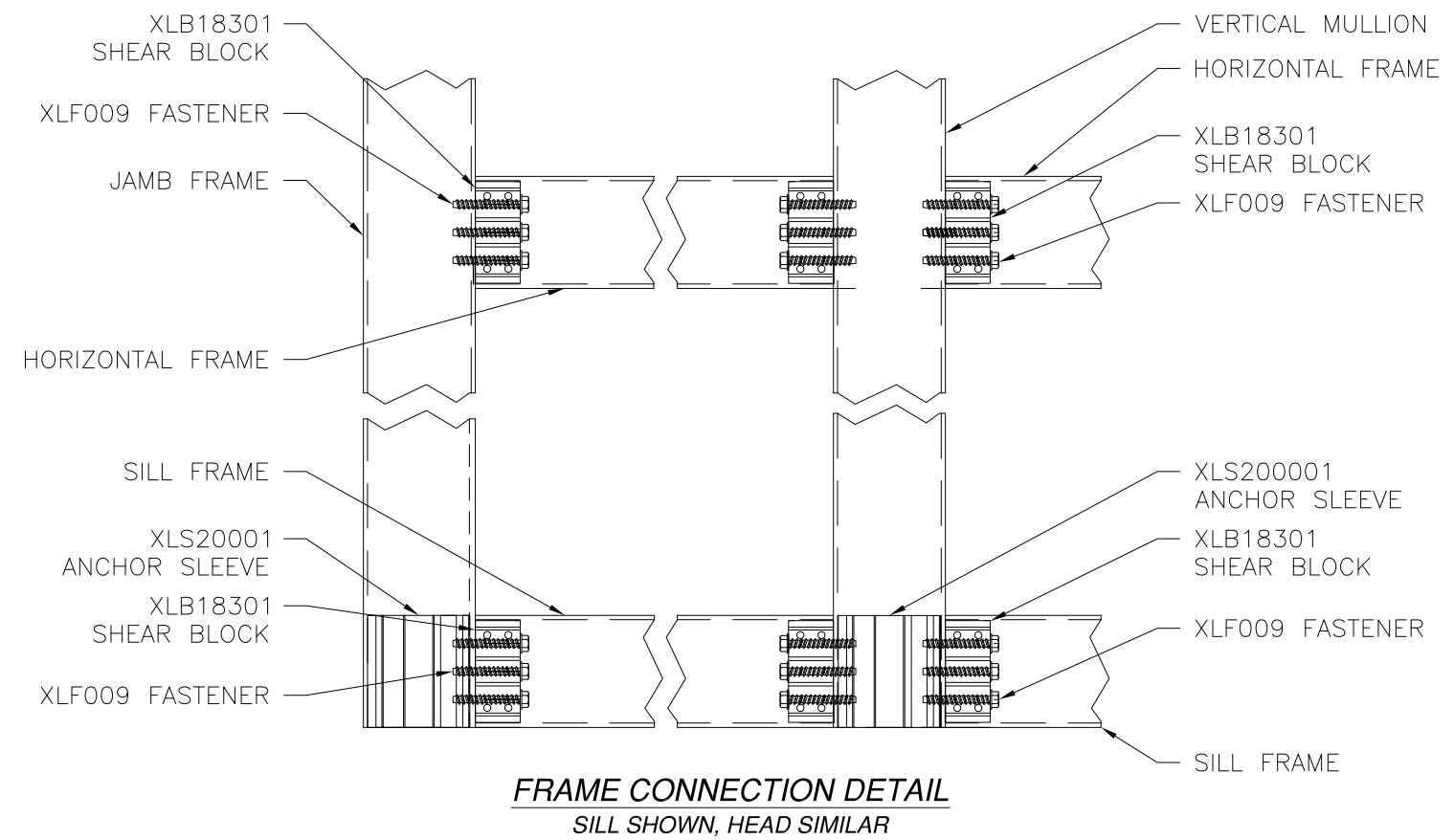

**FRAME CONNECTION DETAIL**  
SILL SHOWN, HEAD SIMILAR

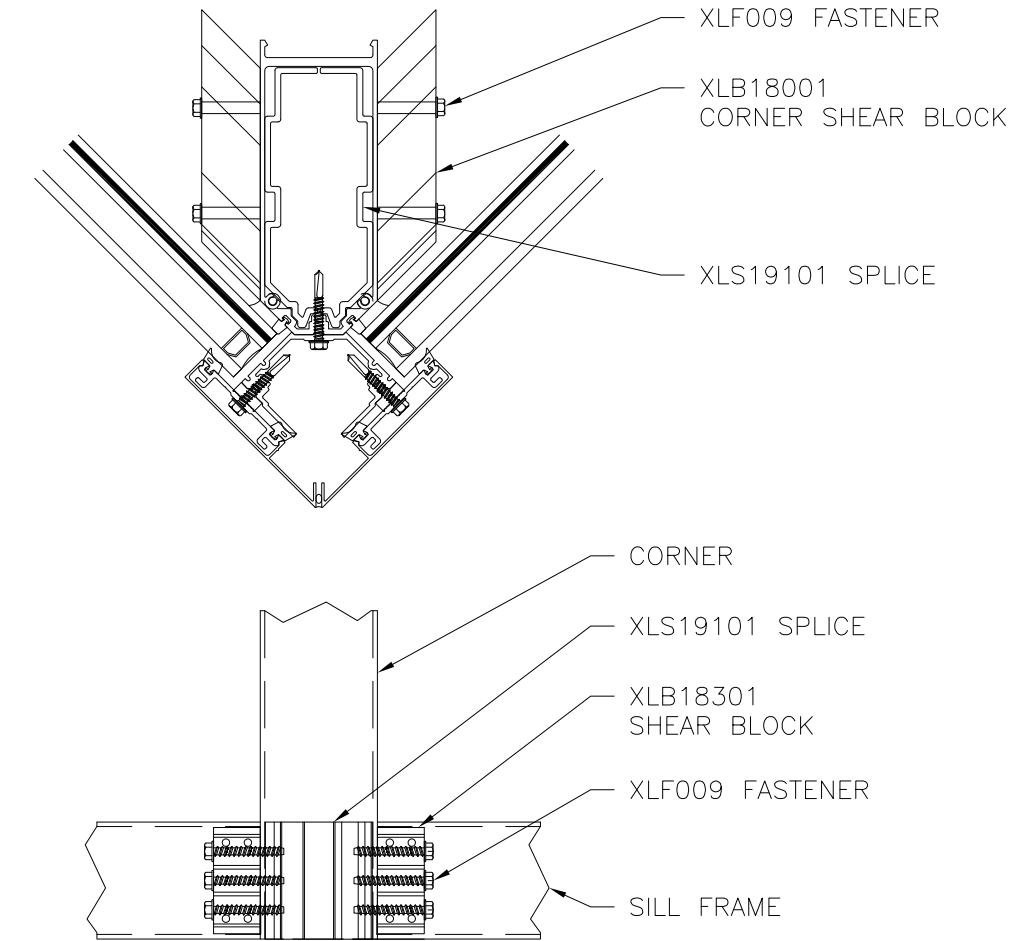

**CORNER FRAME CONNECTION DETAIL**  
SILL SHOWN, HEAD SIMILAR

SIGNED: 12/15/2016

**US ALUMINUM**  
DIVISION OF C.R. LAURENCE CO., INC.  
2503 E. VERNON AVE., LOS ANGELES, CA 90058

STORM WALL XL HURRICANE RESISTANT  
CURTAIN WALL – WET GLAZED – SMI HVHZ  
INSTALLATION DETAILS

DRAWN: R.L.	DWG NO. 08-03021	REV -
SCALE NTS	DATE 12/07/16	SHEET 20 OF 24

L. ROBERTO LOMAS P.E.  
1432 WOODFORD RD LEWISVILLE, NC 27023  
434-688-0609 rllomas@rlomaspe.com

Luis R. Lomas P.E.  
FL No.: 62514

REVISIONS			
REV	DESCRIPTION	DATE	APPROVED

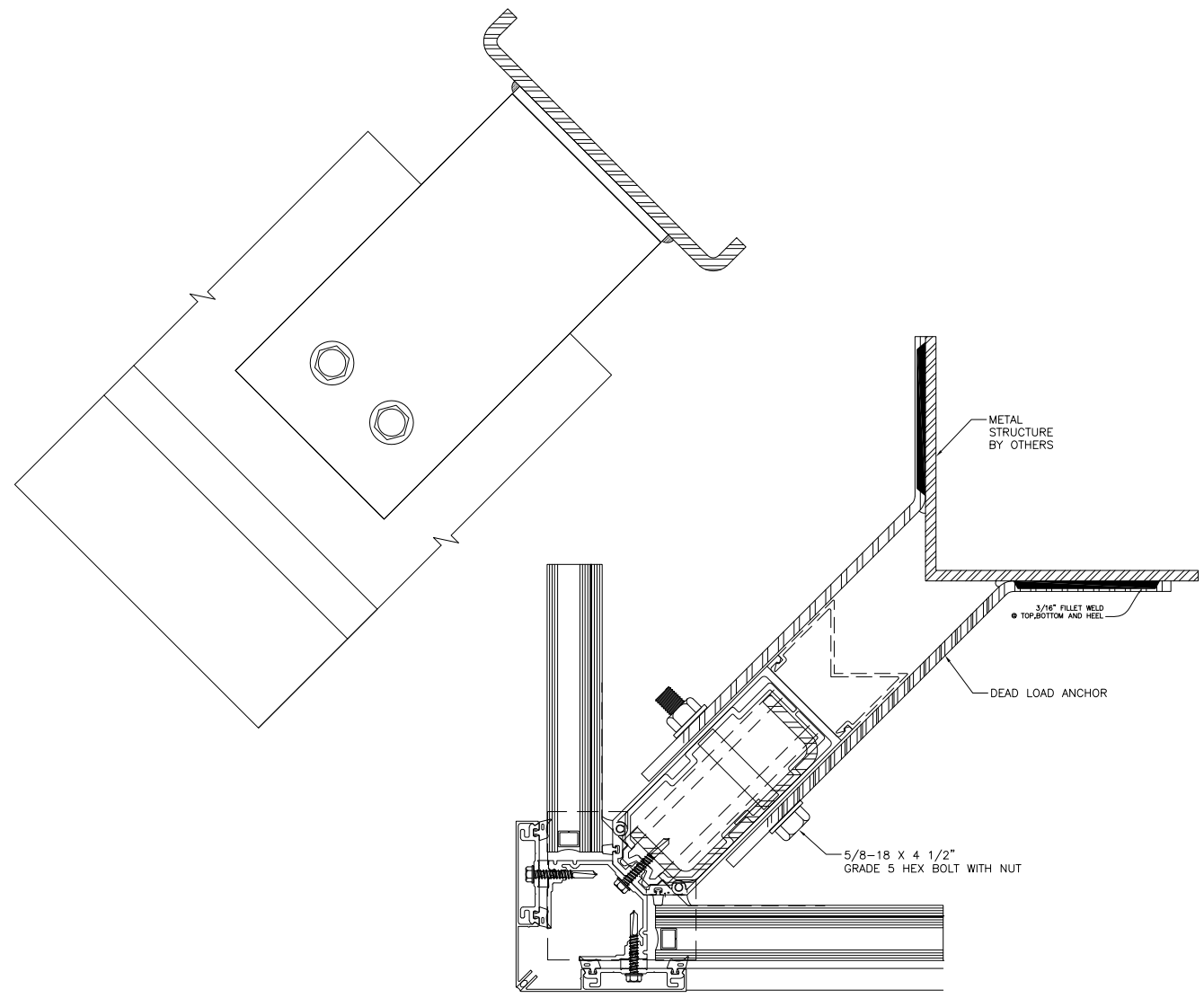

**CORNER DEAD LOAD ANCHORS  
AT MIDSPAN DETAIL**

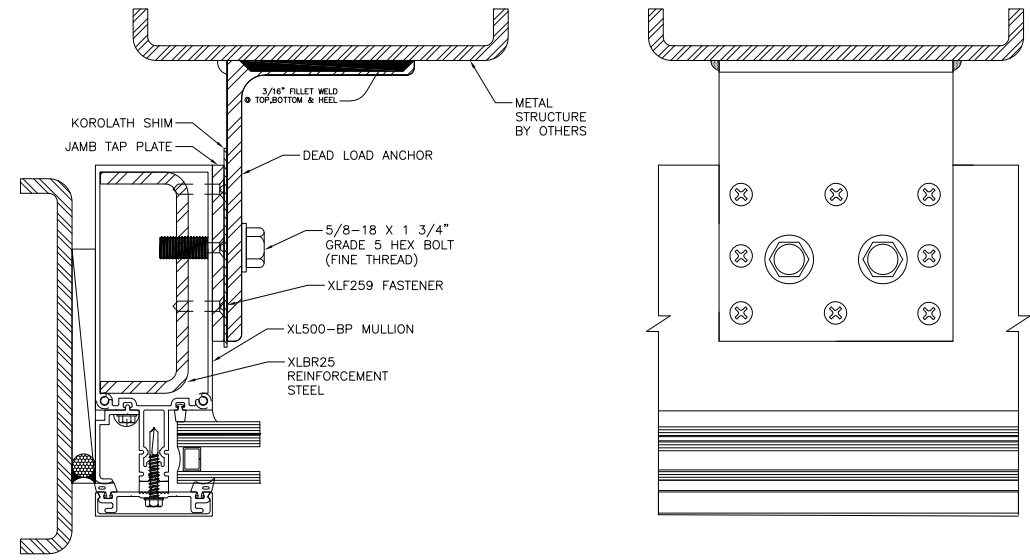

**JAMB DEAD LOAD ANCHORS  
AT MIDSPAN DETAIL**

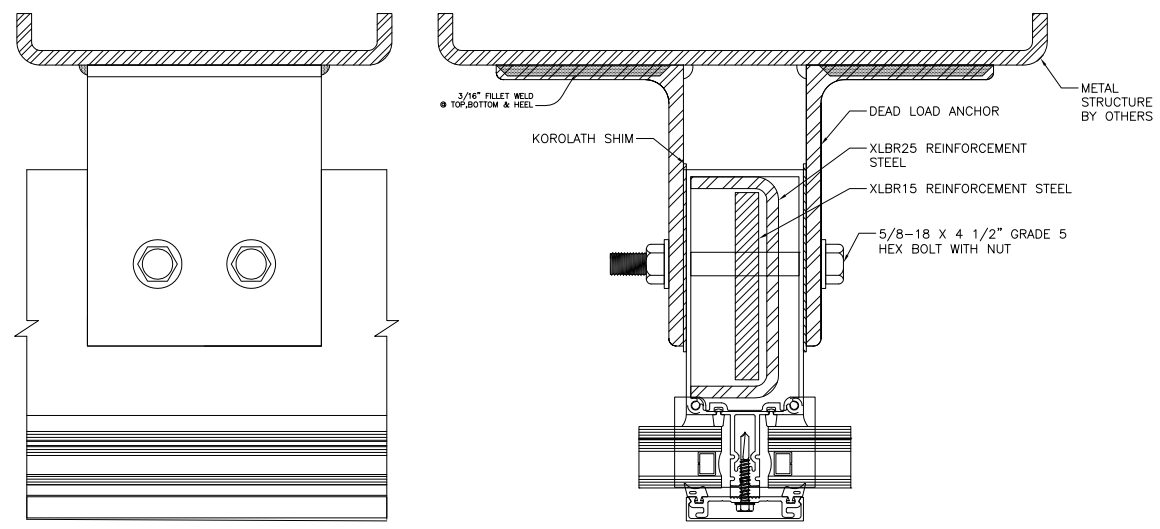

**MULLION DEAD LOAD ANCHORS  
AT MIDSPAN DETAIL**

SIGNED: 12/15/2016

**US ALUMINUM**  
 DIVISION OF C.R. LAURENCE CO., INC.  
 2503 E. VERNON AVE., LOS ANGELES, CA 90058

STORM WALL XL HURRICANE RESISTANT  
 CURTAIN WALL – WET GLAZED – SMI HVHZ  
 INSTALLATION DETAILS

DRAWN: R.L.	DWG NO. 08-03021	REV -
SCALE NTS	DATE 12/07/16	SHEET 21 OF 24

L. ROBERTO LOMAS P.E.  
 1432 WOODFORD RD LEWISVILLE, NC 27023  
 434-688-0609 rllomas@rlomaspe.com

Luis R. Lomas P.E.  
 FL No.: 62514

REVISIONS			
REV	DESCRIPTION	DATE	APPROVED

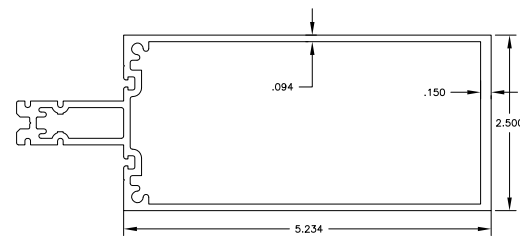

XL500-BP MULLION

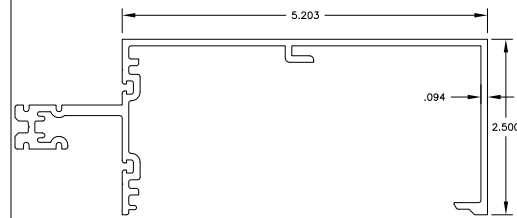

XL532-BP ROLL OVER HORIZONTAL

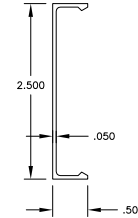

XL110-BP FACE CAP

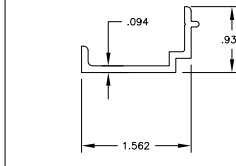

XL122-BP FILLER

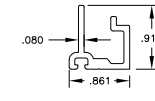

XL130-BP ADAPTOR

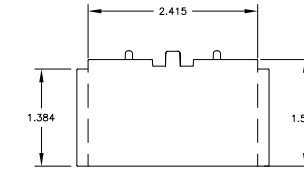

XLD350 SSG BRIDGE

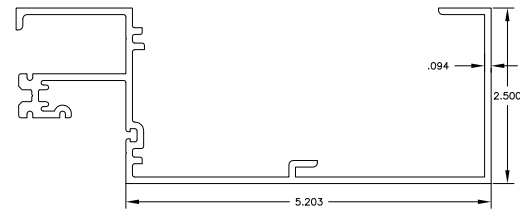

XL501-BP HEAD

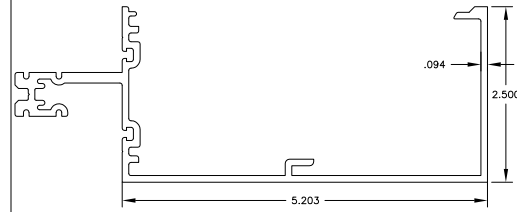

XL533-BP ROLL UNDER HORIZONTAL

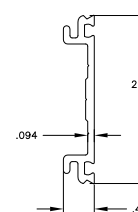

XL162-BP PRESSURE PLATE

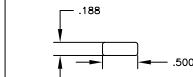

XLSB2101 SETTING BLOCK



XLSB2102 SETTING BLOCK

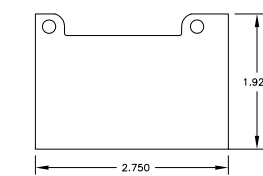

XLC338 JAMB CAP

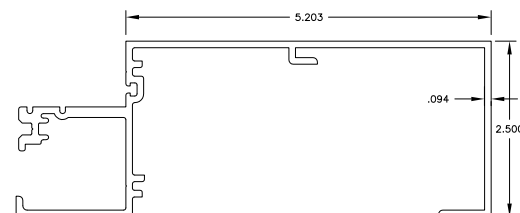

XL502-BP SILL

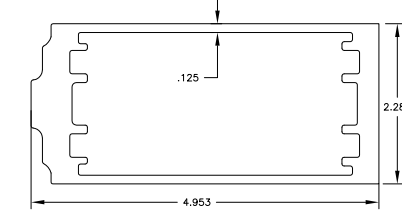

XLS200 STANDARD SLEEVE

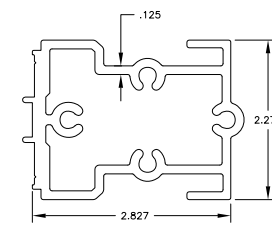

XLB18301 SHEAR BLOCK

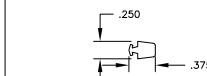

FG-5185 GASKET

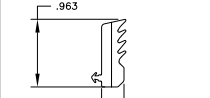

XLG1015 GASKET

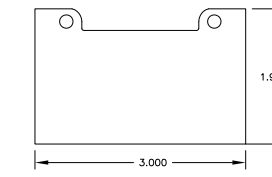

XLC325 MULL CAP

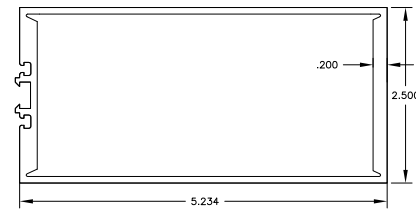

XL504-BP SSG MULLION

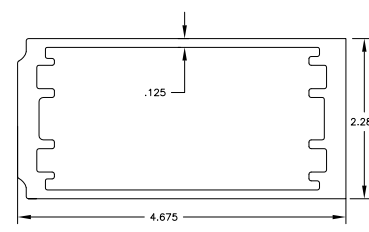

XLS20101 HEAVY SLEEVE

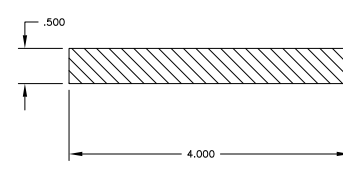

XLBR15 STEEL REINFORCEMENT

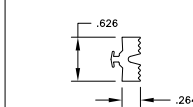

XLG107 ISOLATOR

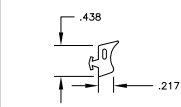

XLG117 GASKET

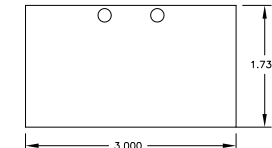

XLS358 SSG MULL CAP

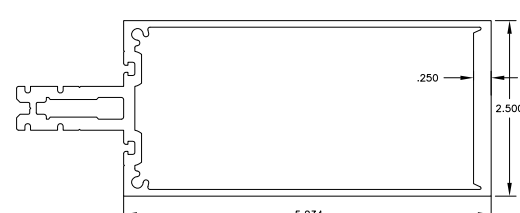

XL510-BP HEAVY MULLION

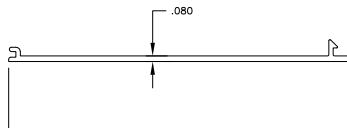

XL237-BP FILLER

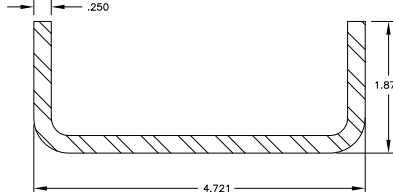

XLBR25 STEEL REINFORCEMENT

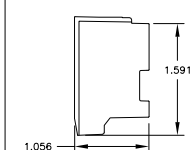

XLD352 ZONE PLUG

SIGNED: 12/15/2016

**US ALUMINUM**  
 DIVISION OF C.R. LAURENCE CO., INC.  
 2503 E. VERNON AVE., LOS ANGELES, CA 90058

STORM WALL XL HURRICANE RESISTANT  
 CURTAIN WALL - WET GLAZED - SMI HVHZ  
 COMPONENTS

DRAWN: R.L.	DWG NO. 08-03021	REV -
SCALE NTS	DATE 12/07/16	SHEET 22 OF 24

L. ROBERTO LOMAS P.E.  
 1432 WOODFORD RD LEWISVILLE, NC 27023  
 434-688-0609 rllomas@rlomaspe.com

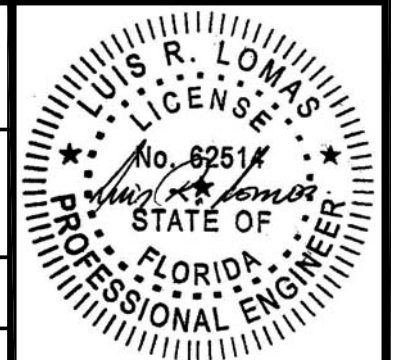

Luis R. Lomas P.E.  
 FL No.: 62514

REVISIONS			
REV	DESCRIPTION	DATE	APPROVED

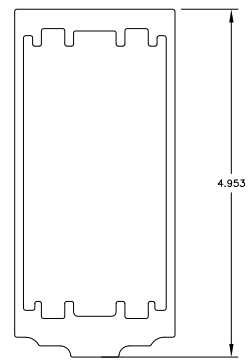

XLS20001  
STANDARD ANCHOR SLEEVE

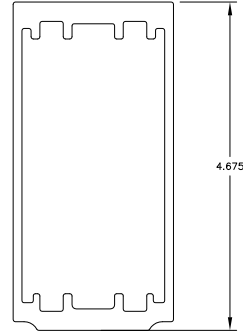

XLS20101 HEAVY  
ANCHOR SLEEVE

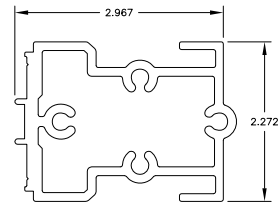

XLB18301  
SHEAR BLOCK

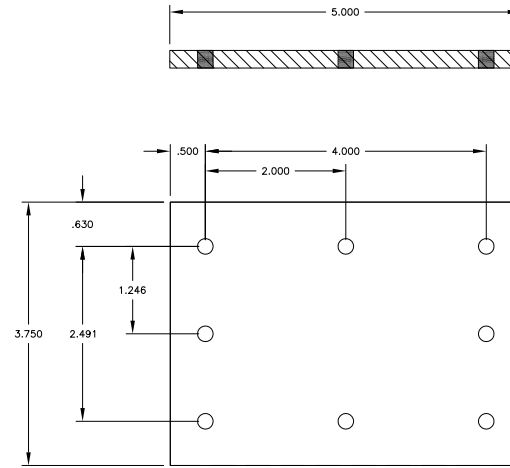

JAMB TAP PLATE  
1/4" STEEL

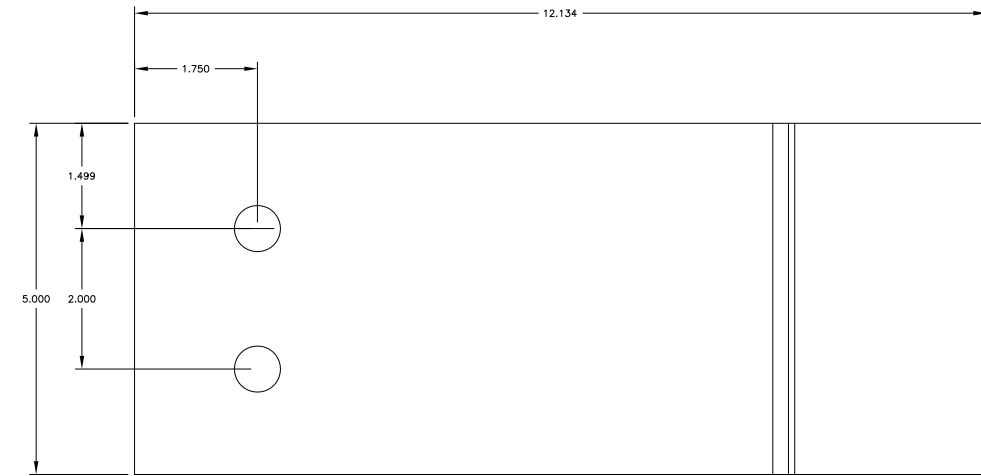
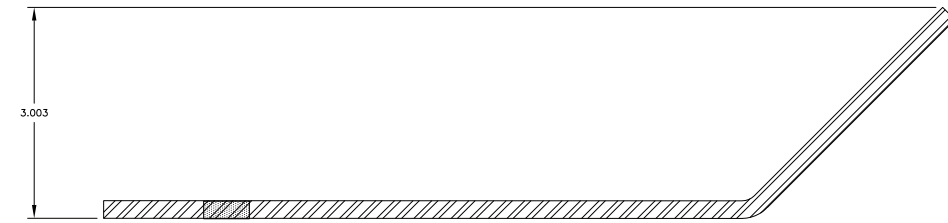

CORNER DEAD LOAD  
ANCHOR  
5/16" STEEL ANGLE

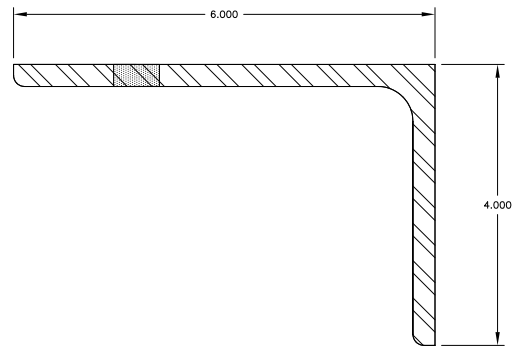

DEAD LOAD ANCHOR  
5/16" STEEL ANGLE

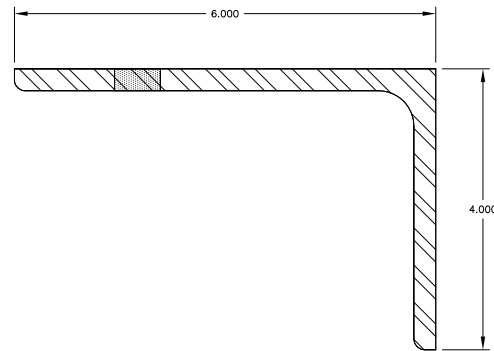

WIND LOAD ANCHOR  
5/16" STEEL ANGLE

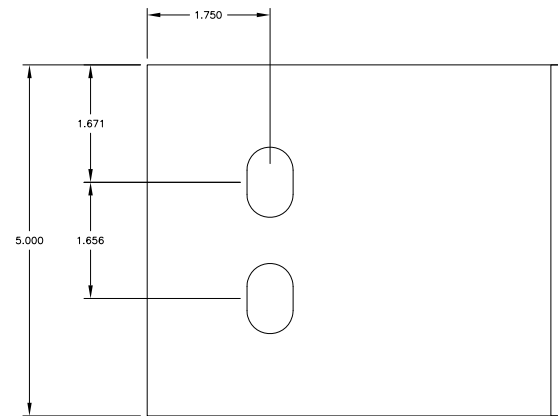
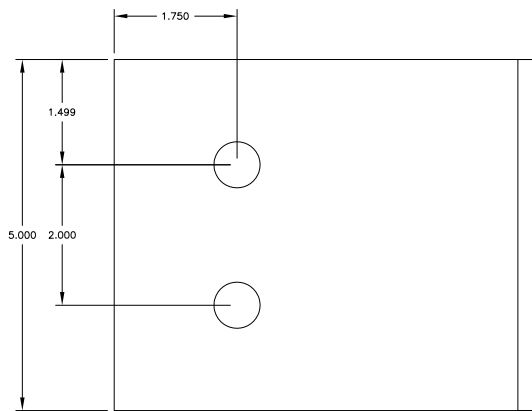

US ALUMINUM  
DIVISION OF C.R. LAURENCE CO., INC.  
2503 E. VERNON AVE., LOS ANGELES, CA 90058

STORM WALL XL HURRICANE RESISTANT  
CURTAIN WALL - WET GLAZED - SMI HVHZ  
COMPONENTS

DRAWN: R.L.	DWG NO. 08-03021	REV -
SCALE NTS	DATE 12/07/16	SHEET 23 OF 24

L. ROBERTO LOMAS P.E.  
1432 WOODFORD RD LEWISVILLE, NC 27023  
434-688-0609 rllomas@rlomaspe.com

SIGNED: 12/15/2016

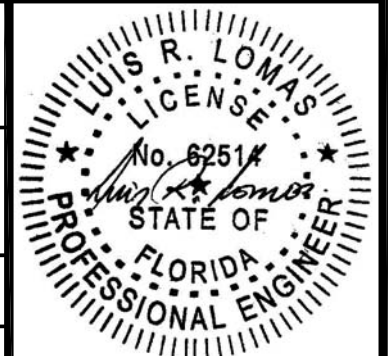

Luis R. Lomas P.E.  
FL No.: 62514

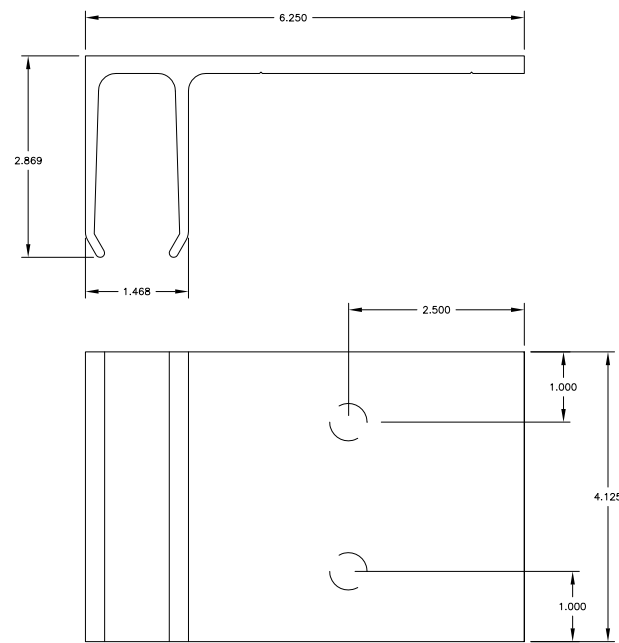

XLA10301 "F" ANCHOR CLIP  
6063-T6 ALUMINUM

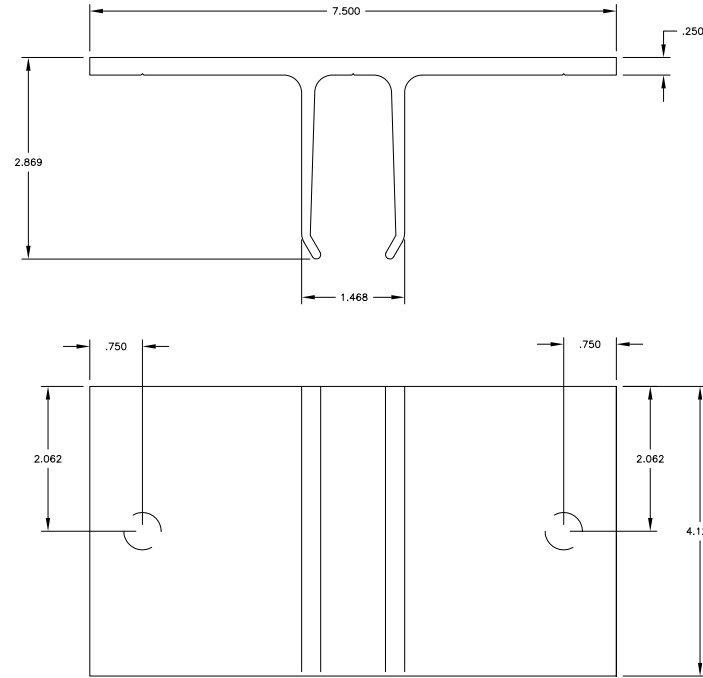

XLA10501 "T" ANCHOR CLIP  
6063-T6 ALUMINUM

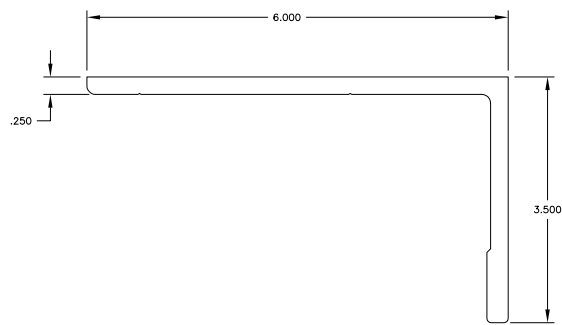

XLA17401 "L" ANCHOR CLIP  
6063-T6 ALUMINUM

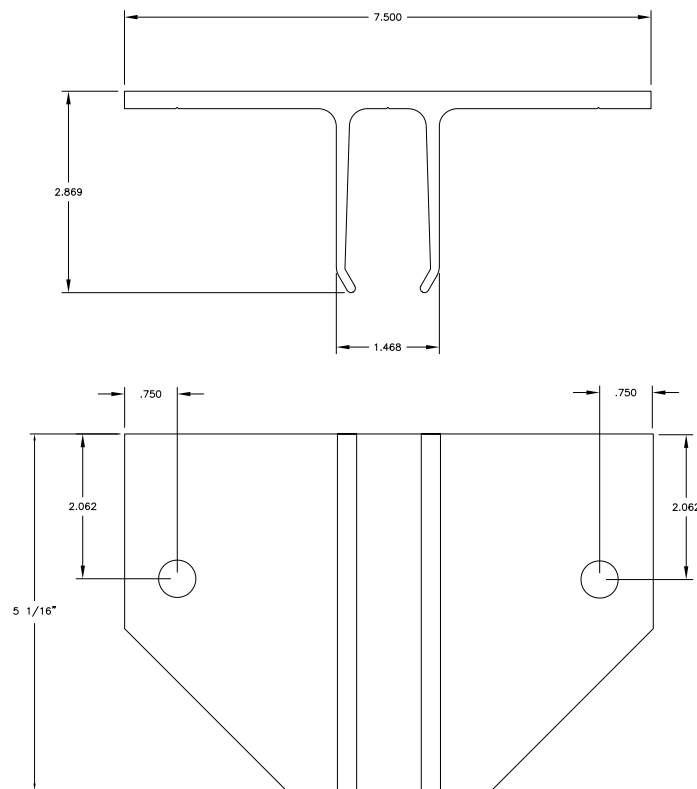

XLA10503 CORNER "T" ANCHOR CLIP  
6063-T6 ALUMINUM

REVISIONS			
REV	DESCRIPTION	DATE	APPROVED

**US ALUMINUM**  
DIVISION OF C.R. LAURENCE CO., INC.  
2503 E. VERNON AVE., LOS ANGELES, CA 90058

STORM WALL XL HURRICANE RESISTANT  
CURTAIN WALL – WET GLAZED – SMI HVHZ  
COMPONENTS

DRAWN: R.L.	DWG NO. 08-03021	REV -
SCALE NTS	DATE 12/07/16	SHEET 24 OF 24

L. ROBERTO LOMAS P.E.  
1432 WOODFORD RD LEWISVILLE, NC 27023  
434-688-0609 rllomas@rlomaspe.com

SIGNED: 12/15/2016

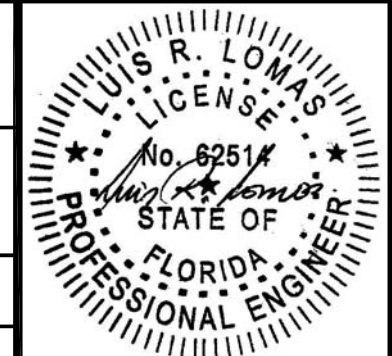

Luis R. Lomas P.E.  
FL No.: 62514