

REVISIONS			
REV	DESCRIPTION	DATE	APPROVED
A	REVISED PER NEW CODE	10/26/2023	R.L.

NOTES:

1. THE PRODUCT SHOWN HEREIN IS DESIGNED AND MANUFACTURED TO COMPLY WITH REQUIREMENTS OF THE FLORIDA BUILDING CODE.
2. WOOD FRAMING AND MASONRY OPENING TO BE DESIGNED AND ANCHORED TO PROPERLY TRANSFER ALL LOADS TO STRUCTURE. FRAMING AND MASONRY OPENING IS THE RESPONSIBILITY OF THE ARCHITECT OR ENGINEER OF RECORD.
3. WHERE SHIM OR BUCK THICKNESS IS LESS THAN 1-1/2" WINDOW UNITS MUST BE ANCHORED THROUGH THE FRAME IN ACCORDANCE WITH MANUFACTURER'S PUBLISHED INSTALLATION INSTRUCTIONS. ANCHORS SHALL BE SECURELY FASTENED DIRECTLY INTO MASONRY, CONCRETE OR OTHER STRUCTURAL SUBSTRATE MATERIAL.
4. WHERE WOOD BUCK THICKNESS IS 1-1/2" OR GREATER, BUCK SHALL BE SECURELY FASTENED TO MASONRY, CONCRETE OR OTHER STRUCTURAL SUBSTRATE. WINDOW UNITS MAY BE ANCHORED THROUGH FRAME TO SECURED WOOD BUCK IN ACCORDANCE WITH MANUFACTURER'S PUBLISHED INSTALLATION INSTRUCTIONS.
5. WHERE 1X BUCK IS NOT USED DISSIMILAR MATERIALS MUST BE SEPARATED WITH APPROVED COATING OR MEMBRANE. SELECTION OF COATING OR MEMBRANE IS THE RESPONSIBILITY OF THE ARCHITECT OR ENGINEER OF RECORD.
6. BUCKS SHALL EXTEND BEYOND WINDOW INTERIOR FACE SO THAT FULL FRAME SUPPORT IS PROVIDED.
7. SHIM AS NEEDED AT EACH ANCHOR LOCATION WITH LOAD BEARING SHIM. SHIM WHERE SPACE OF 1/16" OR GREATER OCCURS. MAXIMUM ALLOWABLE SHIM STACK TO BE 1/4".
8. SHIMS SHALL BE LOCATED, APPLIED AND MADE FROM MATERIALS AND THICKNESS CAPABLE OF SUSTAINING APPLICABLE LOADS.
9. WIND LOAD DURATION FACTOR Cd=1.6 WAS USED FOR WOOD ANCHOR CALCULATIONS.
10. FRAME MATERIAL: EXTRUDED RIGID PVC.
11. UNITS MUST BE GLAZED PER ASTM E1300.
12. APPROVED IMPACT PROTECTIVE SYSTEM IS NOT REQUIRED FOR THIS PRODUCT IN WIND BORNE DEBRIS REGIONS.

13. FOR ANCHORING THROUGH FIN INTO WOOD FRAMING OR 2X BUCK USE #6 WOOD SCREWS WITH SUFFICIENT LENGTH TO ACHIEVE A 1 1/4" MINIMUM EMBEDMENT INTO SUBSTRATE. LOCATE ANCHORS AS SHOWN IN ELEVATIONS AND INSTALLATION DETAILS.
14. FOR ANCHORING THROUGH FRAME INTO WOOD FRAMING OR 2X BUCK USE #8 WOOD SCREWS WITH SUFFICIENT LENGTH TO ACHIEVE A 1 1/4" MINIMUM EMBEDMENT INTO SUBSTRATE. LOCATE ANCHORS AS SHOWN IN ELEVATIONS AND INSTALLATION DETAILS.
15. FOR ANCHORING THROUGH FRAME INTO MASONRY/CONCRETE USE 3/16" TAPCONS WITH SUFFICIENT LENGTH TO ACHIEVE A 1 1/4" MINIMUM EMBEDMENT INTO SUBSTRATE WITH 2" MINIMUM EDGE DISTANCE. LOCATE ANCHORS AS SHOWN IN ELEVATIONS AND INSTALLATION DETAILS.
16. FOR ANCHORING THROUGH FRAME INTO METAL STRUCTURE USE #8 SMS OR SELF DRILLING SCREWS WITH SUFFICIENT LENGTH TO ACHIEVE 3 THREADS MINIMUM BEYOND STRUCTURE INTERIOR WALL. LOCATE ANCHORS AS SHOWN IN ELEVATIONS AND INSTALLATION DETAILS.
17. ALL FASTENERS TO BE CORROSION RESISTANT.
18. INSTALLATION ANCHORS SHALL BE INSTALLED IN ACCORDANCE WITH ANCHOR MANUFACTURER'S INSTALLATION INSTRUCTIONS AND ANCHORS SHALL NOT BE USED IN SUBSTRATES WITH STRENGTHS LESS THAN THE MINIMUM STRENGTH SPECIFIED BELOW:
  - 18.1. WOOD: MINIMUM SPECIFIC GRAVITY OF G=0.42
  - 18.2. CONCRETE: MINIMUM COMPRESSIVE STRENGTH OF 2,000 PSI.
  - 18.3. MASONRY: HOLLOW/FILLED BLOCK PER ASTM C90 WITH Fm=2,000PSI MINIMUM.
  - 18.4. METAL STRUCTURE: STEEL 18GA (.048") FY=33KSI/FU=52KSI OR ALUMINUM 6063-T5 FU=30KSI 1/8" THICK MINIMUM

SIGNED: 10/26/2023

TABLE OF CONTENTS	
SHEET NO.	DESCRIPTION
1	NOTES
2	ELEVATIONS
3 - 12	INSTALLATION DETAILS
13	COMPONENTS

MI WINDOWS AND DOORS LLC 650 WEST MARKET STREET GRATZ, PA 17030		
SERIES 1630 HS REINFORCED IMPACT 73" X 48" NOTES		
DRAWN: A.R.	DWG NO. 08-03144	REV A
SCALE NTS	DATE 07/19/17	SHEET 1 OF 13
L. ROBERTO LOMAS P.E. 208 7th Ave, INDIALANTIC, FL 32903 434-688-0609 rllomas@lrlomaspe.com		

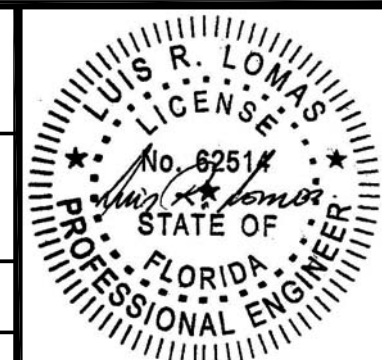

Luis R. Lomas P.E.  
FL No.: 62514

REVISIONS			
REV	DESCRIPTION	DATE	APPROVED
A	REVISED PER NEW CODE	10/26/2023	R.L.

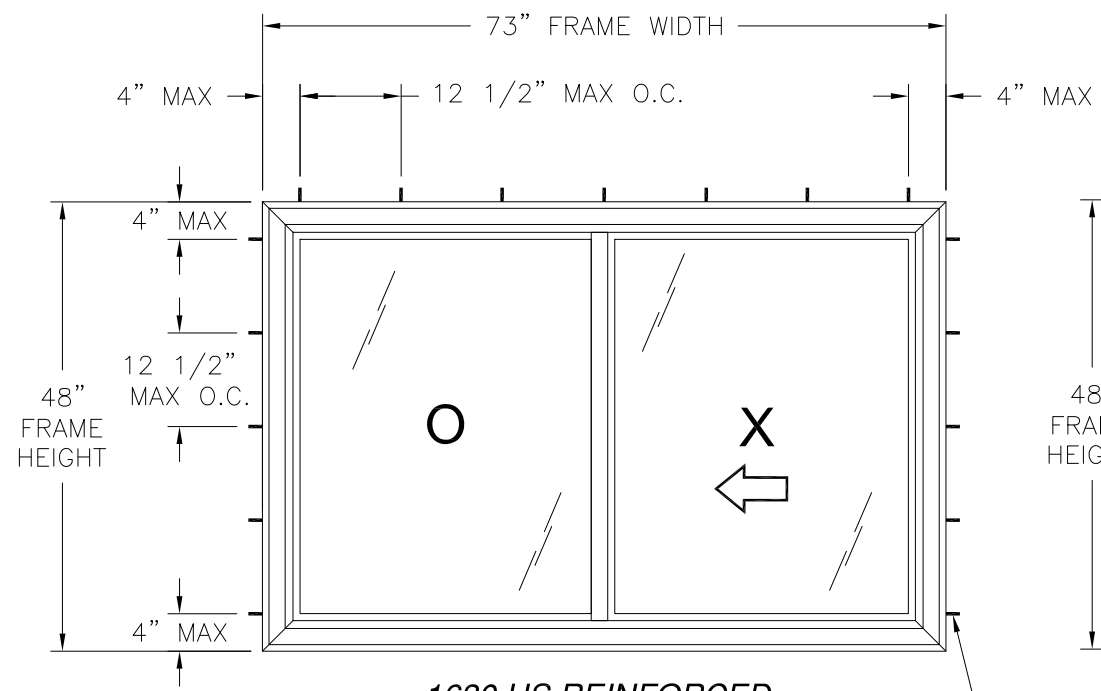

**1630 HS REINFORCED**  
EXTERIOR VIEW  
FINLESS & FLANGE INSTALLATION

FOR NUMBER OF ANCHORS REQUIRED SEE CHART #1

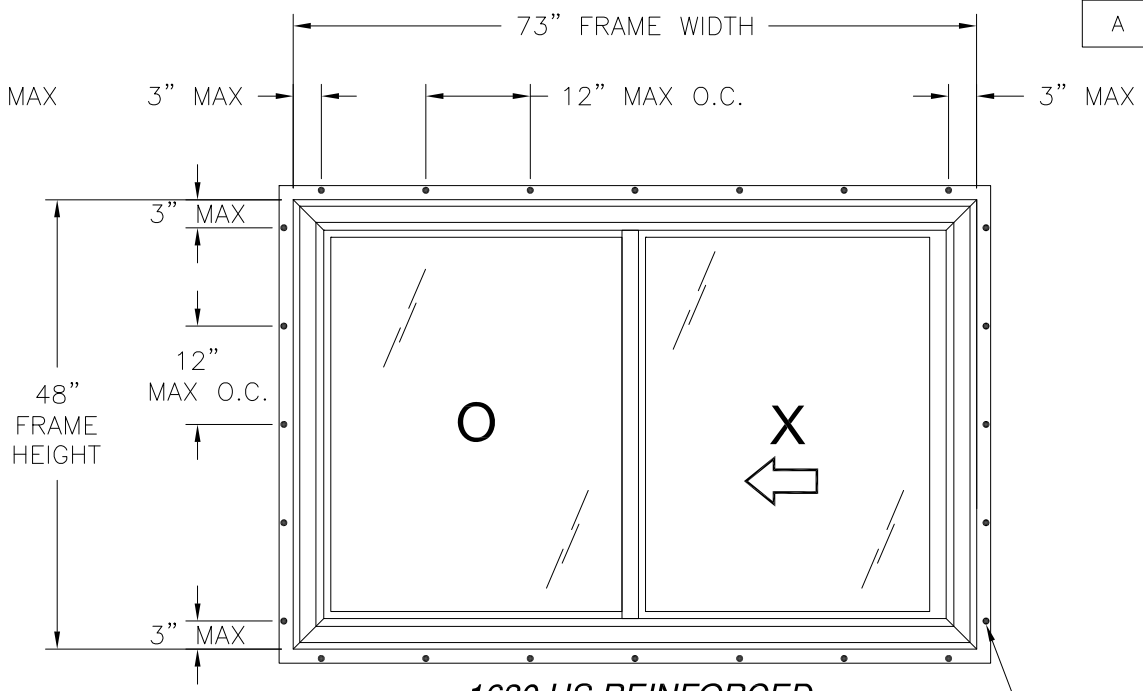

**1630 HS REINFORCED**  
EXTERIOR VIEW  
FIN INSTALLATION

FOR NUMBER OF ANCHORS REQUIRED SEE CHART #2

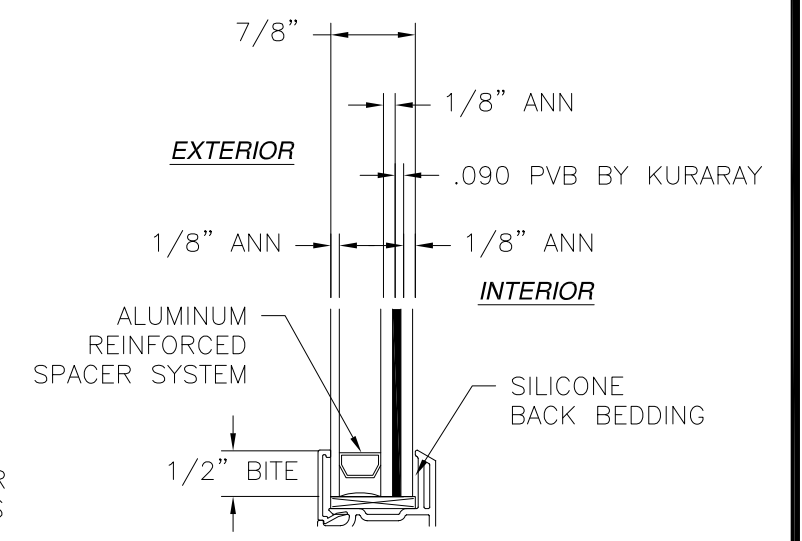

**GLAZING DETAIL**

DESIGN PRESSURE RATING	IMPACT RATING
<b>±50PSF</b>	<b>LARGE AND SMALL MISSILE IMPACT</b>

MISSILE LEVEL D, WIND ZONE 3

Chart #1														
Number of anchor locations required														
Frame Height (in)	Frame Width (in)													
	36.00		42.00		48.00		54.00		60.00		66.00		73.00	
	Head	Jamb	Head	Jamb	Head	Jamb	Head	Jamb	Head	Jamb	Head	Jamb	Head	Jamb
36.00	4	4	4	4	5	4	5	4	6	4	6	4	7	4
42.00	4	4	4	4	5	4	5	4	6	4	6	4	7	4
48.00	4	5	4	5	5	5	5	5	6	5	6	5	7	5

Chart #2														
Number of anchor locations required														
Frame Height (in)	Frame Width (in)													
	36.00		42.00		48.00		54.00		60.00		66.00		73.00	
	H & S	Jamb	H & S	Jamb	H & S	Jamb	H & S	Jamb	H & S	Jamb	H & S	Jamb	H & S	Jamb
36.00	4	4	4	4	5	4	5	4	6	4	6	4	7	4
42.00	4	4	4	4	5	4	5	4	6	4	6	4	7	4
48.00	4	5	4	5	5	5	5	5	6	5	6	5	7	5

- NOTES:
- SASH SIZE: 36 5/8" X 44 3/4"
  - D.L.O.: 32 11/16" X 43 1/2"

HARDWARE SCHEDULE	
A.	(2) SASH ROLLERS AT BOTTOM RAIL 1 1/2" FROM CORNER OF STILES
B.	(2) METAL LOCK WITH KEEPERS AT LOCK STILE 14" FROM BOTTOM AND TOP RAILS
C.	ALUMINUM REINFORCEMENT (M-2115) AT LOCK STILE
D.	ALUMINUM REINFORCEMENT (AE-000162) AT FIXED MEETING STILE

MI WINDOWS AND DOORS LLC  
650 WEST MARKET STREET  
GRATZ, PA 17030

SERIES 1630 HS REINFORCED  
IMPACT 73" X 48"  
ELEVATIONS

DRAWN: A.R.	DWG NO. 08-03144	REV A
SCALE NTS	DATE 07/19/17	SHEET 2 OF 13

L. ROBERTO LOMAS P.E.  
208 7th Ave, INDIALANTIC, FL 32903  
434-688-0609 rllomas@rlomaspe.com

SIGNED: 10/26/2023

Luis R. Lomas P.E.  
FL No.: 62514

REVISIONS			
REV	DESCRIPTION	DATE	APPROVED
A	REVISED PER NEW CODE	10/26/2023	R.L.

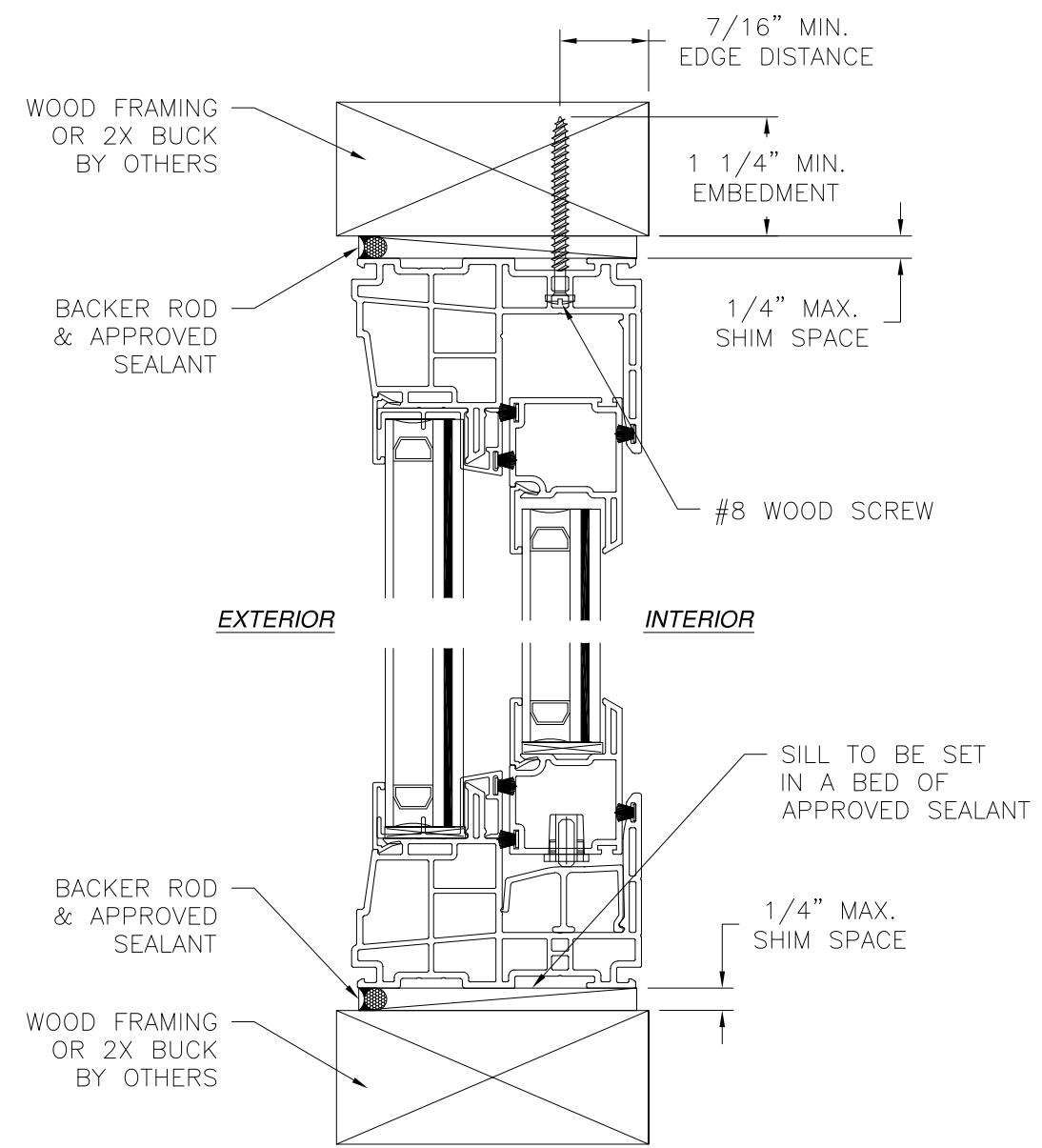

**VERTICAL CROSS SECTION**  
WOOD FRAMING OR 2X BUCK INSTALLATION

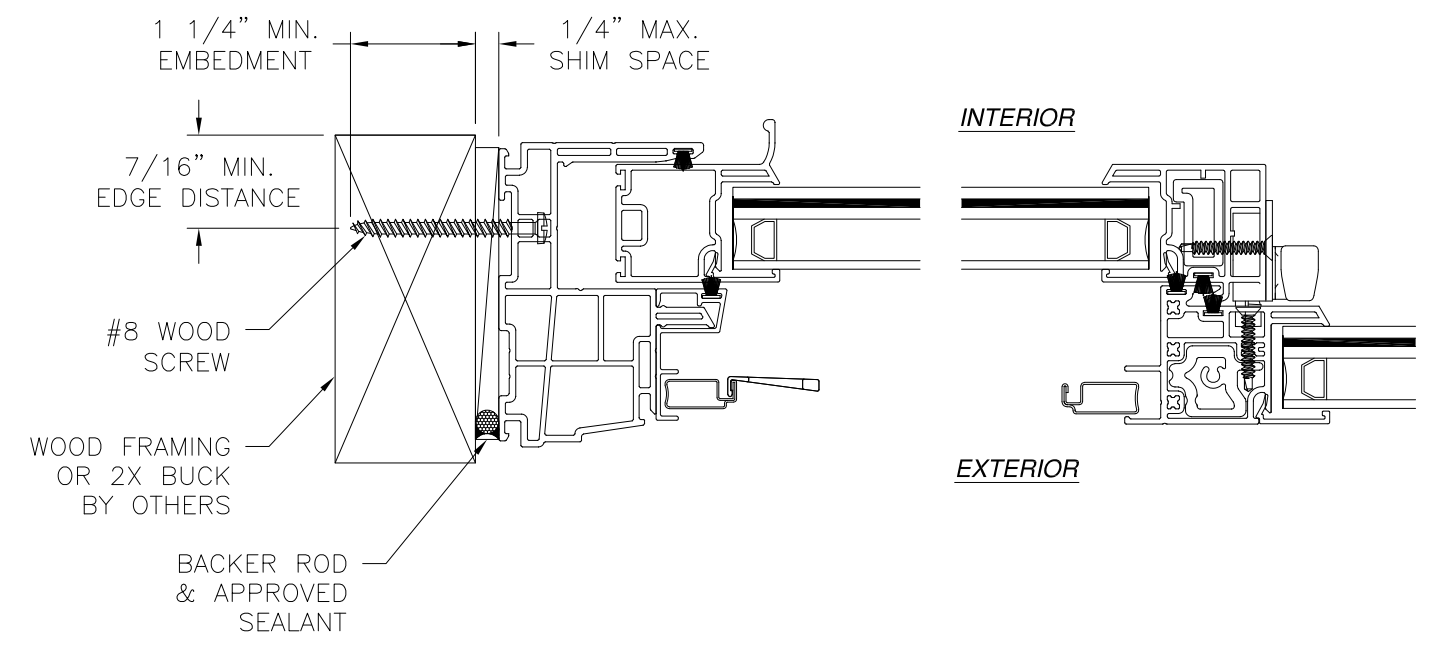

**JAMB INSTALLATION DETAIL**  
WOOD FRAMING OR 2X BUCK INSTALLATION

- NOTES:**
1. INTERIOR AND EXTERIOR FINISHES, BY OTHERS, NOT SHOWN FOR CLARITY.
  2. PERIMETER AND JOINT SEALANT BY OTHERS TO BE DESIGNED IN ACCORDANCE WITH ASTM E2112

MI WINDOWS AND DOORS LLC  
650 WEST MARKET STREET  
GRATZ, PA 17030

SERIES 1630 HS REINFORCED  
IMPACT 73" X 48"  
FINLESS INSTALLATION DETAILS

DRAWN: A.R.	DWG NO. 08-03144	REV A
SCALE NTS	DATE 07/19/17	SHEET 3 OF 13

L. ROBERTO LOMAS P.E.  
208 7th Ave, INDIALANTIC, FL 32903  
434-688-0609 rllomas@lrlomaspe.com

SIGNED: 10/26/2023

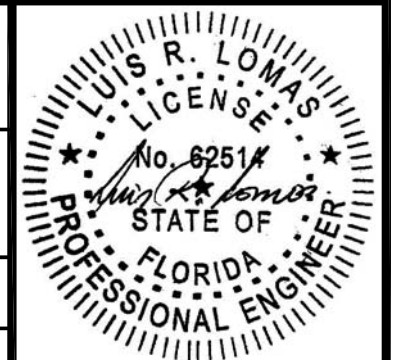

Luis R. Lomas P.E.  
FL No.: 62514

REVISIONS			
REV	DESCRIPTION	DATE	APPROVED
A	REVISED PER NEW CODE	10/26/2023	R.L.

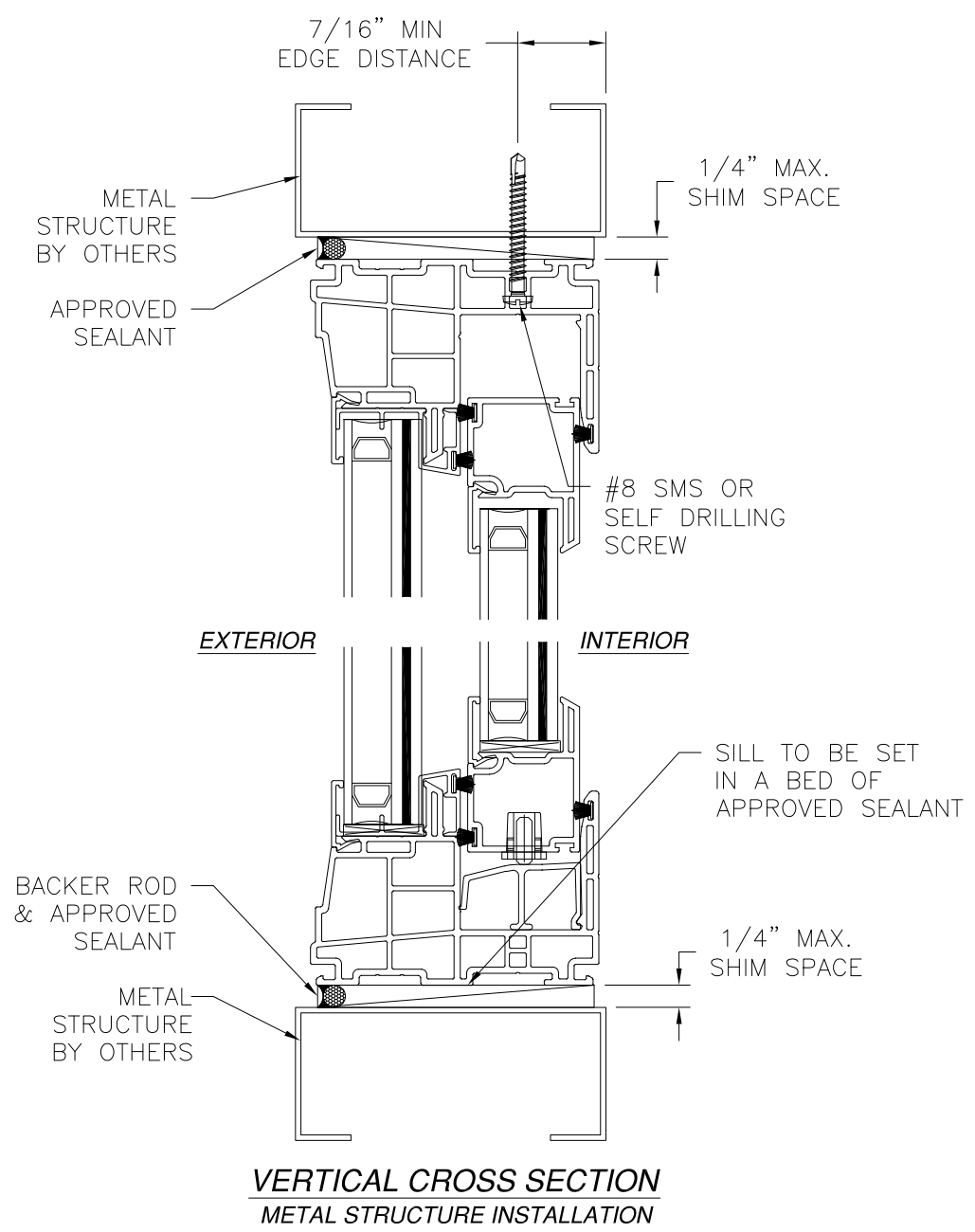

**VERTICAL CROSS SECTION**  
METAL STRUCTURE INSTALLATION

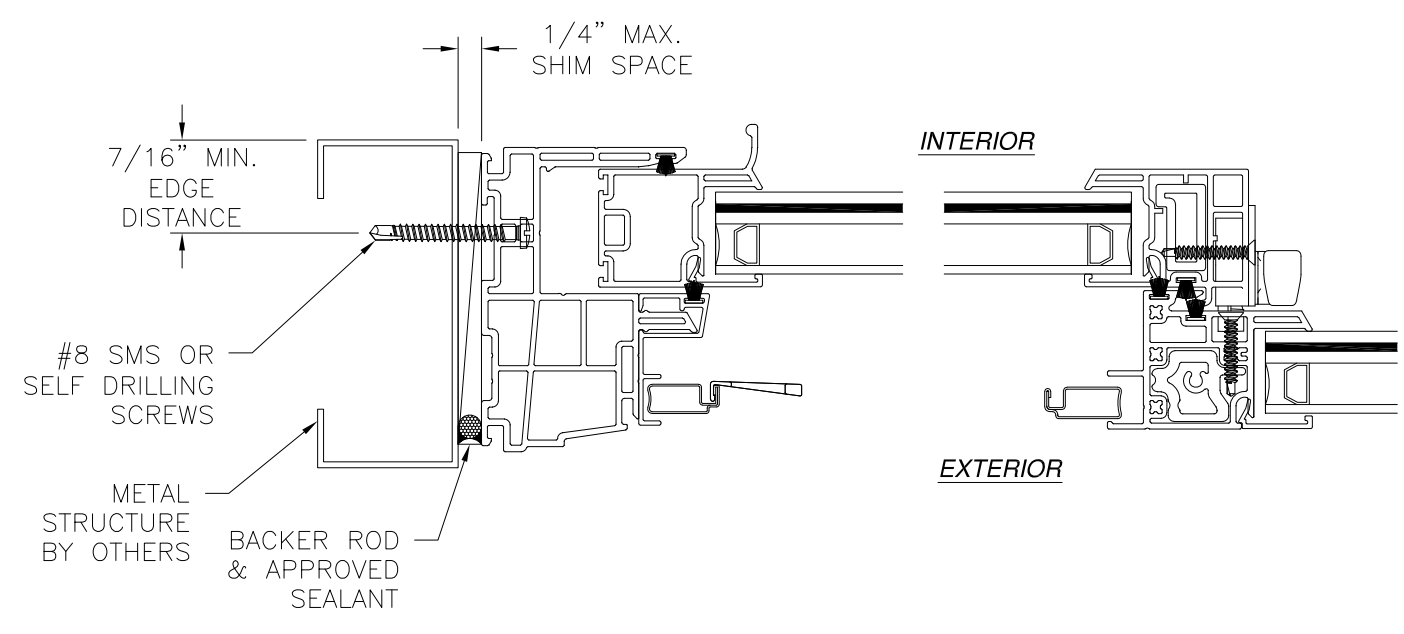

**JAMB INSTALLATION DETAIL**  
METAL STRUCTURE INSTALLATION

- NOTES:**
1. INTERIOR AND EXTERIOR FINISHES, BY OTHERS, NOT SHOWN FOR CLARITY.
  2. PERIMETER AND JOINT SEALANT BY OTHERS TO BE DESIGNED IN ACCORDANCE WITH ASTM E2112

MI WINDOWS AND DOORS LLC  
650 WEST MARKET STREET  
GRATZ, PA 17030

SERIES 1630 HS REINFORCED  
IMPACT 73" X 48"  
FINLESS INSTALLATION DETAILS

DRAWN: A.R.	DWG NO. 08-03144	REV A
SCALE NTS	DATE 07/19/17	SHEET 4 OF 13

L. ROBERTO LOMAS P.E.  
208 7th Ave, INDIALANTIC, FL 32903  
434-688-0609 rllomas@rlomaspe.com

SIGNED: 10/26/2023

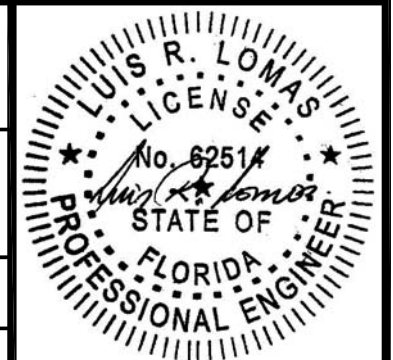

Luis R. Lomas P.E.  
FL No.: 62514

REVISIONS			
REV	DESCRIPTION	DATE	APPROVED
A	REVISED PER NEW CODE	10/26/2023	R.L.

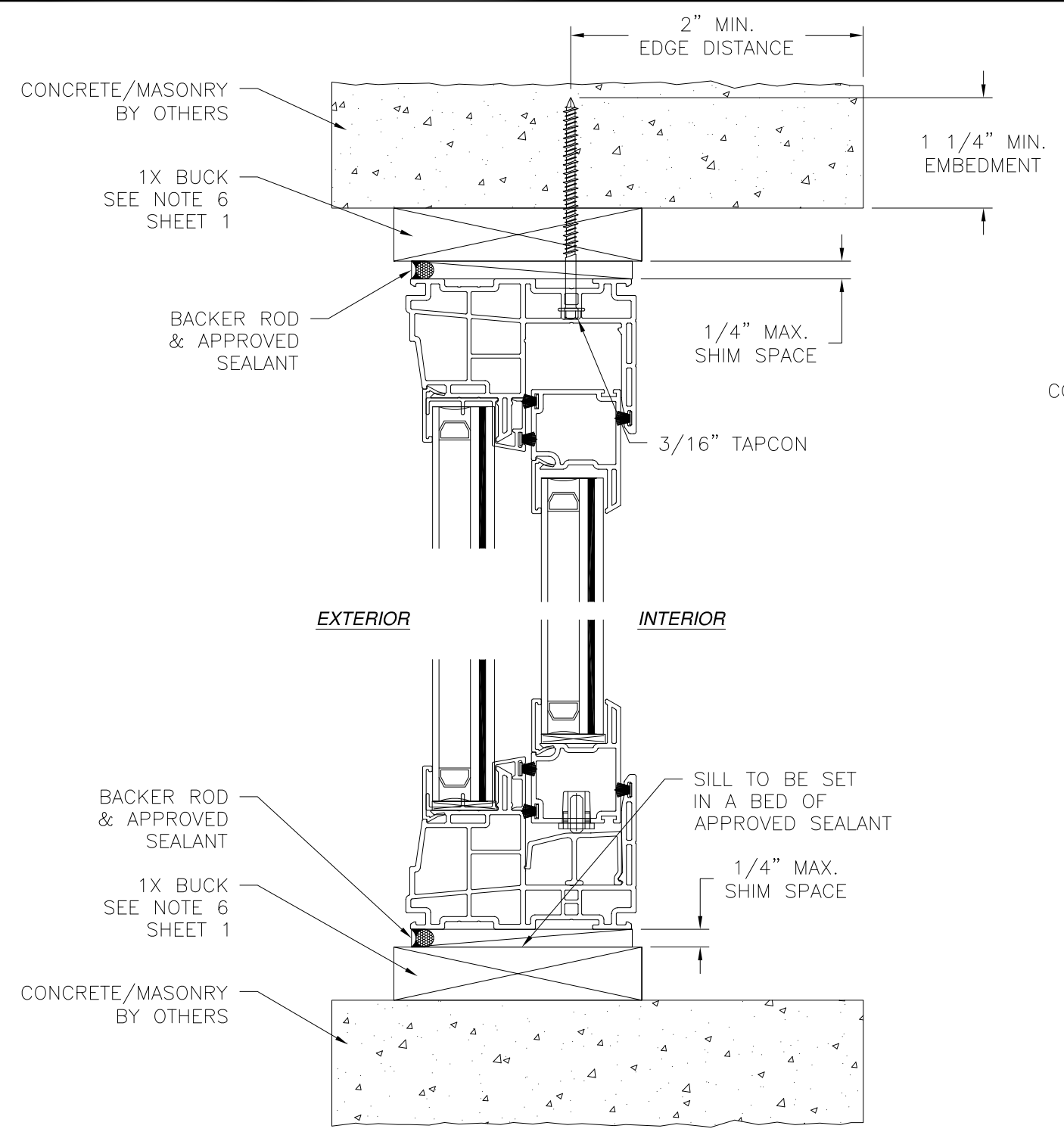

**VERTICAL CROSS SECTION**  
 CONCRETE/MASONRY WITH 1X BUCK INSTALLATION  
 FOR CONCRETE/MASONRY WITHOUT 1X BUCK REFER TO  
 JAMB INSTALLATION DETAIL

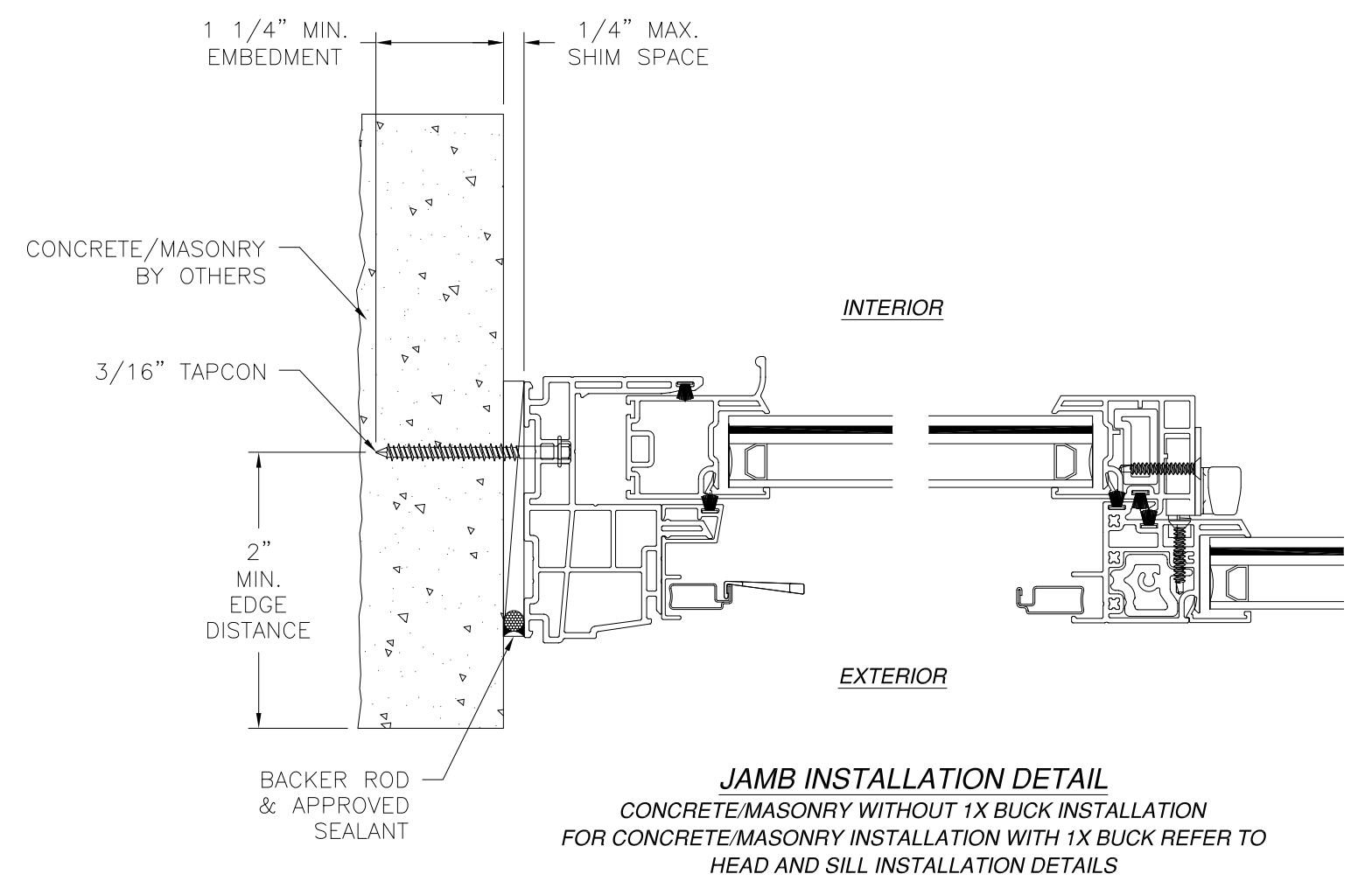

**JAMB INSTALLATION DETAIL**  
 CONCRETE/MASONRY WITHOUT 1X BUCK INSTALLATION  
 FOR CONCRETE/MASONRY WITH 1X BUCK REFER TO  
 HEAD AND SILL INSTALLATION DETAILS

- NOTES:
1. INTERIOR AND EXTERIOR FINISHES, BY OTHERS, NOT SHOWN FOR CLARITY.
  2. PERIMETER AND JOINT SEALANT BY OTHERS TO BE DESIGNED IN ACCORDANCE WITH ASTM E2112

MI WINDOWS AND DOORS LLC  
 650 WEST MARKET STREET  
 GRATZ, PA 17030

SERIES 1630 HS REINFORCED  
 IMPACT 73" X 48"  
 FINLESS INSTALLATION DETAILS

DRAWN: A.R.	DWG NO. 08-03144	REV A
SCALE NTS	DATE 07/19/17	SHEET 5 OF 13

L. ROBERTO LOMAS P.E.  
 208 7th Ave, INDIALANTIC, FL 32903  
 434-688-0609 rllomas@lrlomaspe.com

SIGNED: 10/26/2023

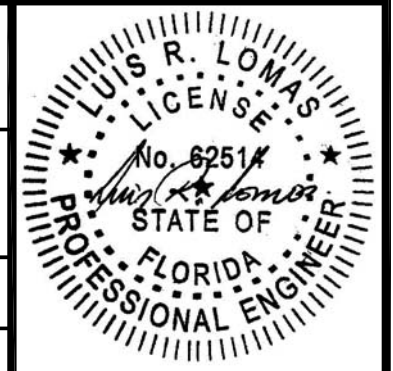

Luis R. Lomas P.E.  
 FL No.: 62514

REVISIONS			
REV	DESCRIPTION	DATE	APPROVED
A	REVISED PER NEW CODE	10/26/2023	R.L.

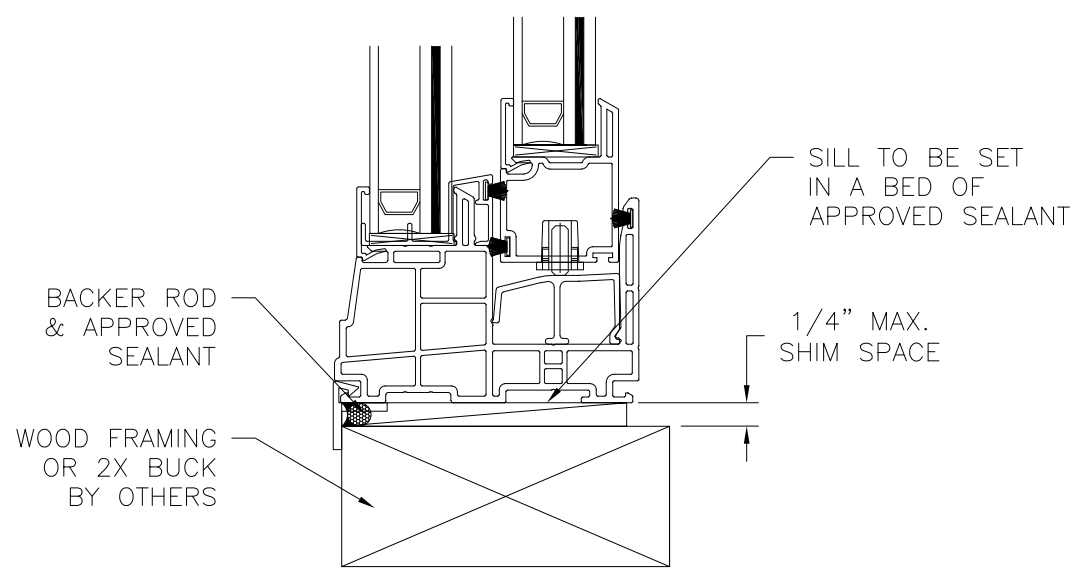
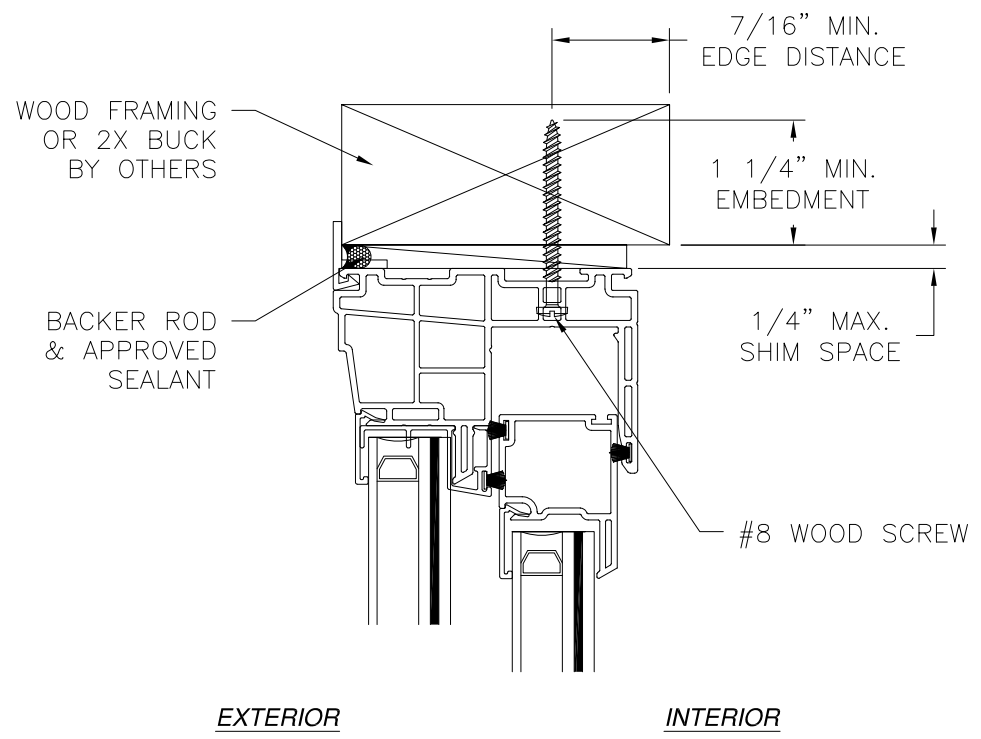

**VERTICAL CROSS SECTION**  
WOOD FRAMING OR 2X BUCK INSTALLATION

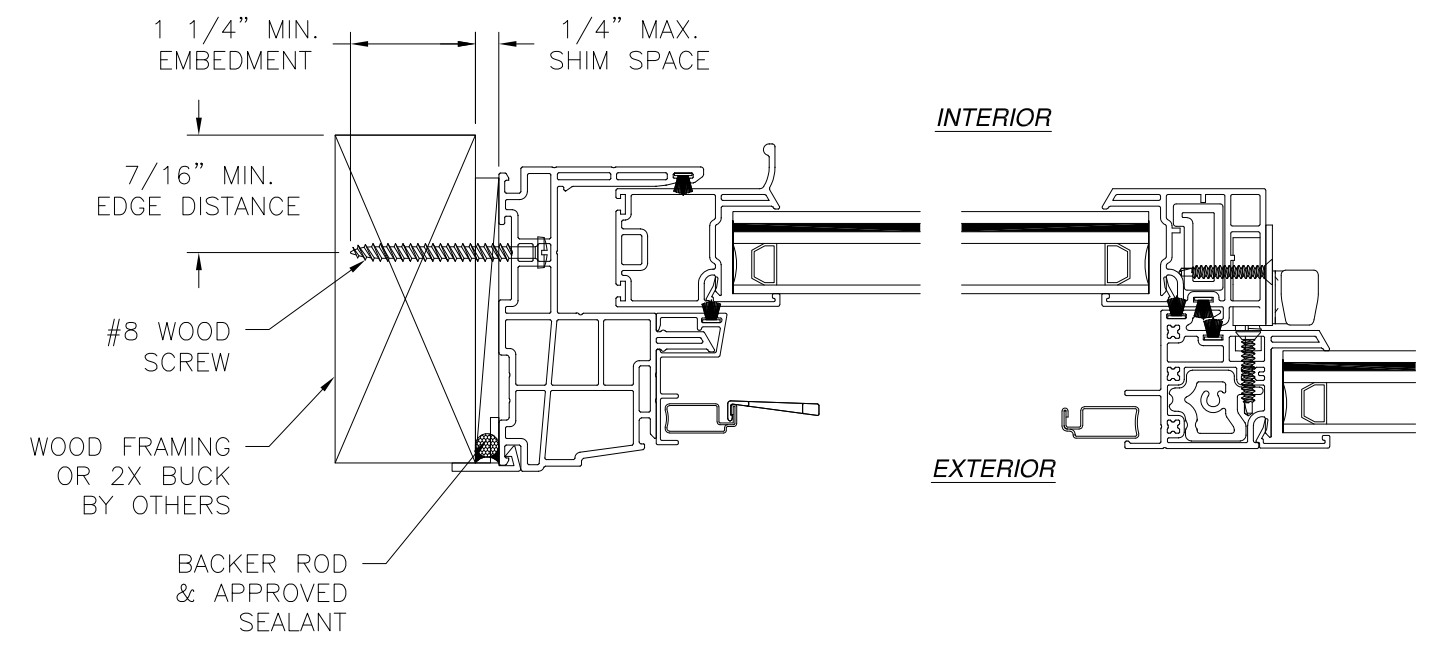

**JAMB INSTALLATION DETAIL**  
WOOD FRAMING OR 2X BUCK INSTALLATION

- NOTES:**
1. INTERIOR AND EXTERIOR FINISHES, BY OTHERS, NOT SHOWN FOR CLARITY.
  2. PERIMETER AND JOINT SEALANT BY OTHERS TO BE DESIGNED IN ACCORDANCE WITH ASTM E2112

MI WINDOWS AND DOORS LLC  
650 WEST MARKET STREET  
GRATZ, PA 17030

SERIES 1630 HS REINFORCED  
IMPACT 73" X 48"  
FLANGE INSTALLATION DETAILS

DRAWN: A.R.	DWG NO. 08-03144	REV A
SCALE NTS	DATE 07/19/17	SHEET 6 OF 13

L. ROBERTO LOMAS P.E.  
208 7th Ave, INDIALANTIC, FL 32903  
434-688-0609 rllomas@lrlomaspe.com

SIGNED: 10/26/2023

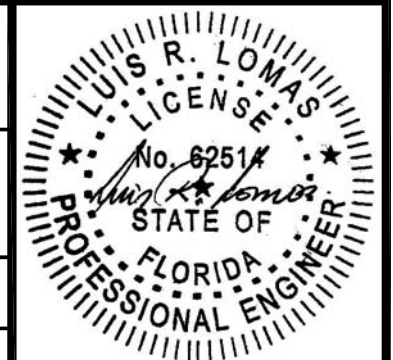

Luis R. Lomas P.E.  
FL No.: 62514

REVISIONS			
REV	DESCRIPTION	DATE	APPROVED
A	REVISED PER NEW CODE	10/26/2023	R.L.

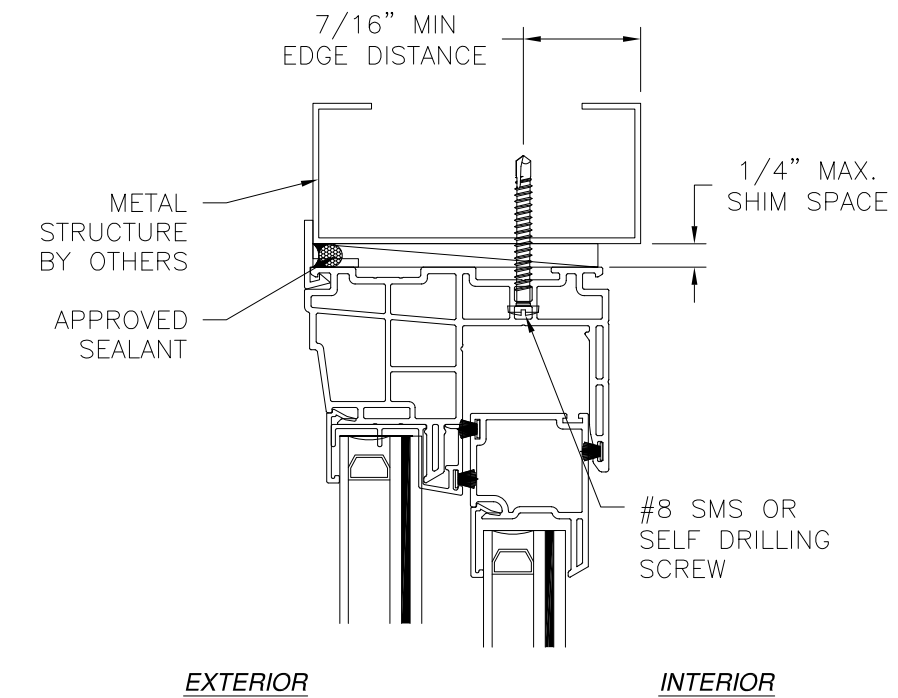

EXTERIOR INTERIOR

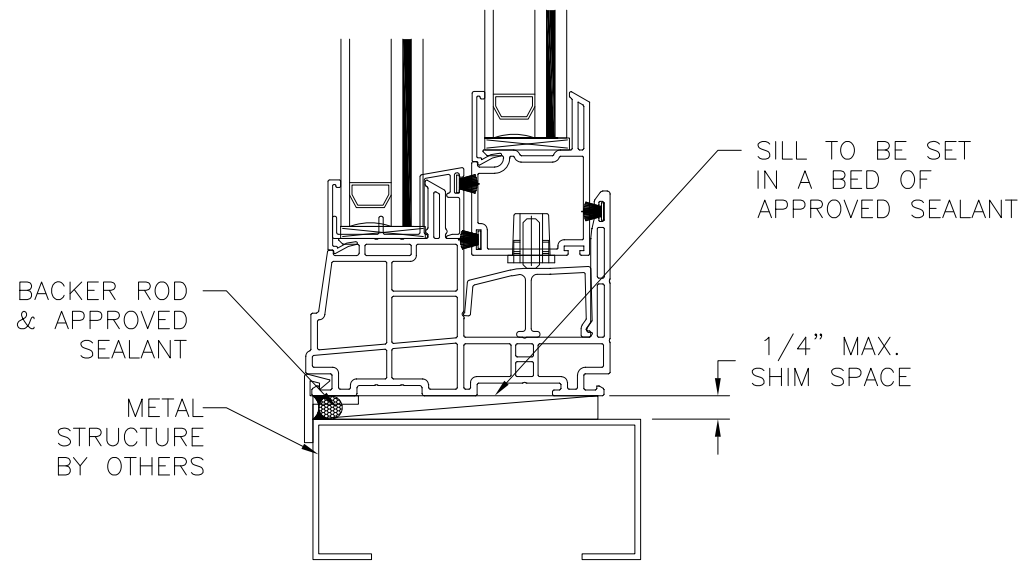

**VERTICAL CROSS SECTION**  
METAL STRUCTURE INSTALLATION

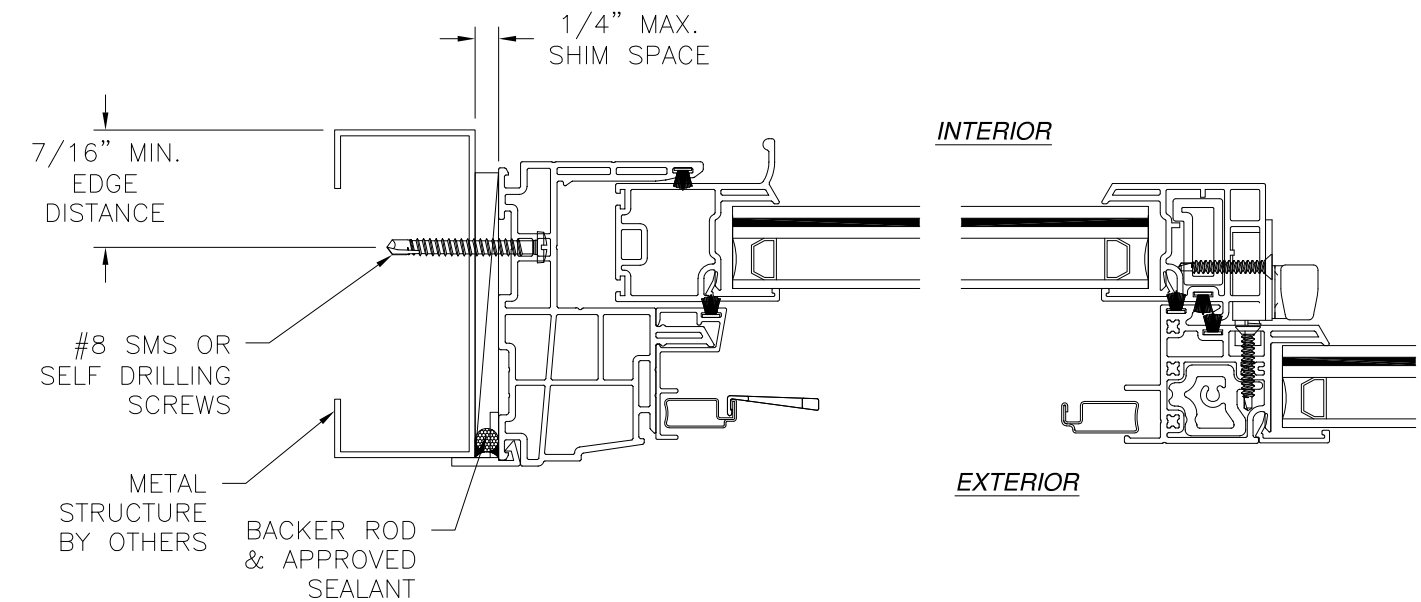

**JAMB INSTALLATION DETAIL**  
METAL STRUCTURE INSTALLATION

- NOTES:
1. INTERIOR AND EXTERIOR FINISHES, BY OTHERS, NOT SHOWN FOR CLARITY.
  2. PERIMETER AND JOINT SEALANT BY OTHERS TO BE DESIGNED IN ACCORDANCE WITH ASTM E2112

MI WINDOWS AND DOORS LLC 650 WEST MARKET STREET GRATZ, PA 17030		
SERIES 1630 HS REINFORCED IMPACT 73" X 48" FLANGE INSTALLATION DETAILS		
DRAWN: A.R.	DWG NO. 08-03144	REV A
SCALE NTS	DATE 07/19/17	SHEET 7 OF 13
L. ROBERTO LOMAS P.E. 208 7th Ave, INDIALANTIC, FL 32903 434-688-0609 rllomas@lrlomaspe.com		

SIGNED: 10/26/2023

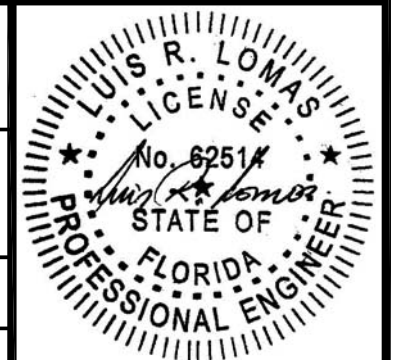

Luis R. Lomas P.E.  
FL No.: 62514

REVISIONS			
REV	DESCRIPTION	DATE	APPROVED
A	REVISED PER NEW CODE	10/26/2023	R.L.

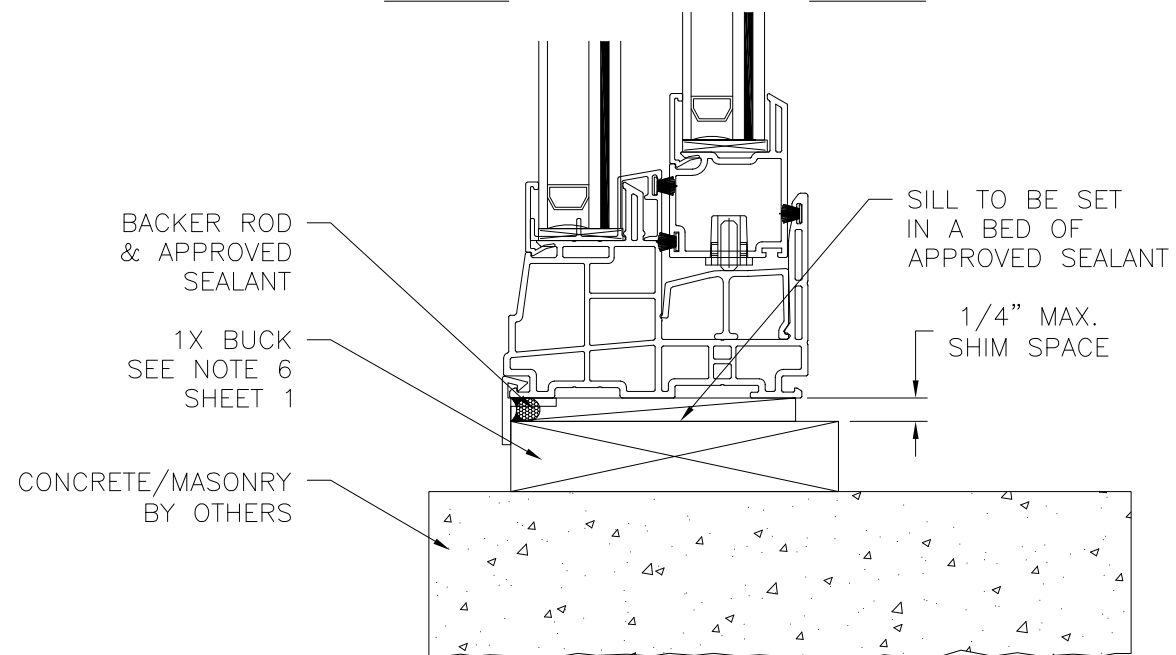
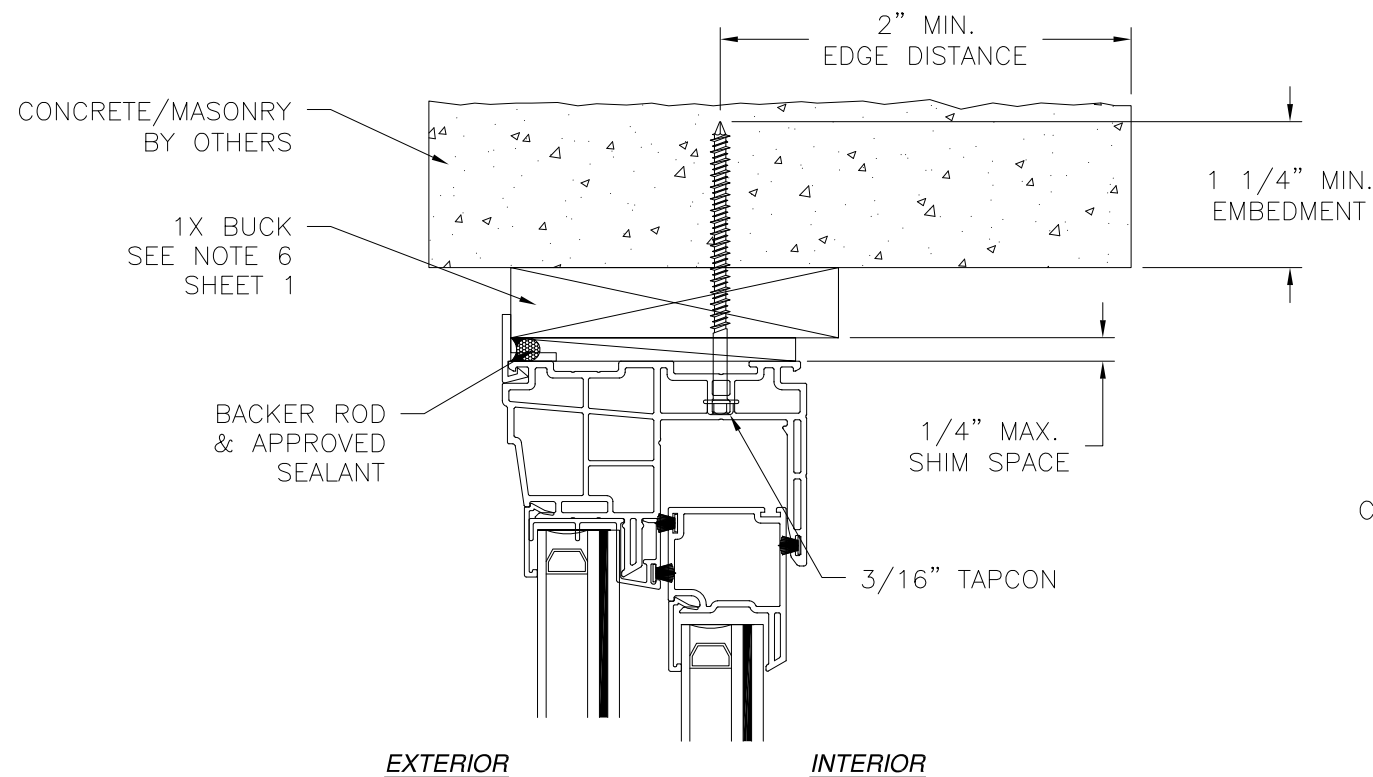

**VERTICAL CROSS SECTION**  
 CONCRETE/MASONRY WITH 1X BUCK INSTALLATION  
 FOR CONCRETE/MASONRY WITHOUT 1X BUCK REFER TO  
 JAMB INSTALLATION DETAIL

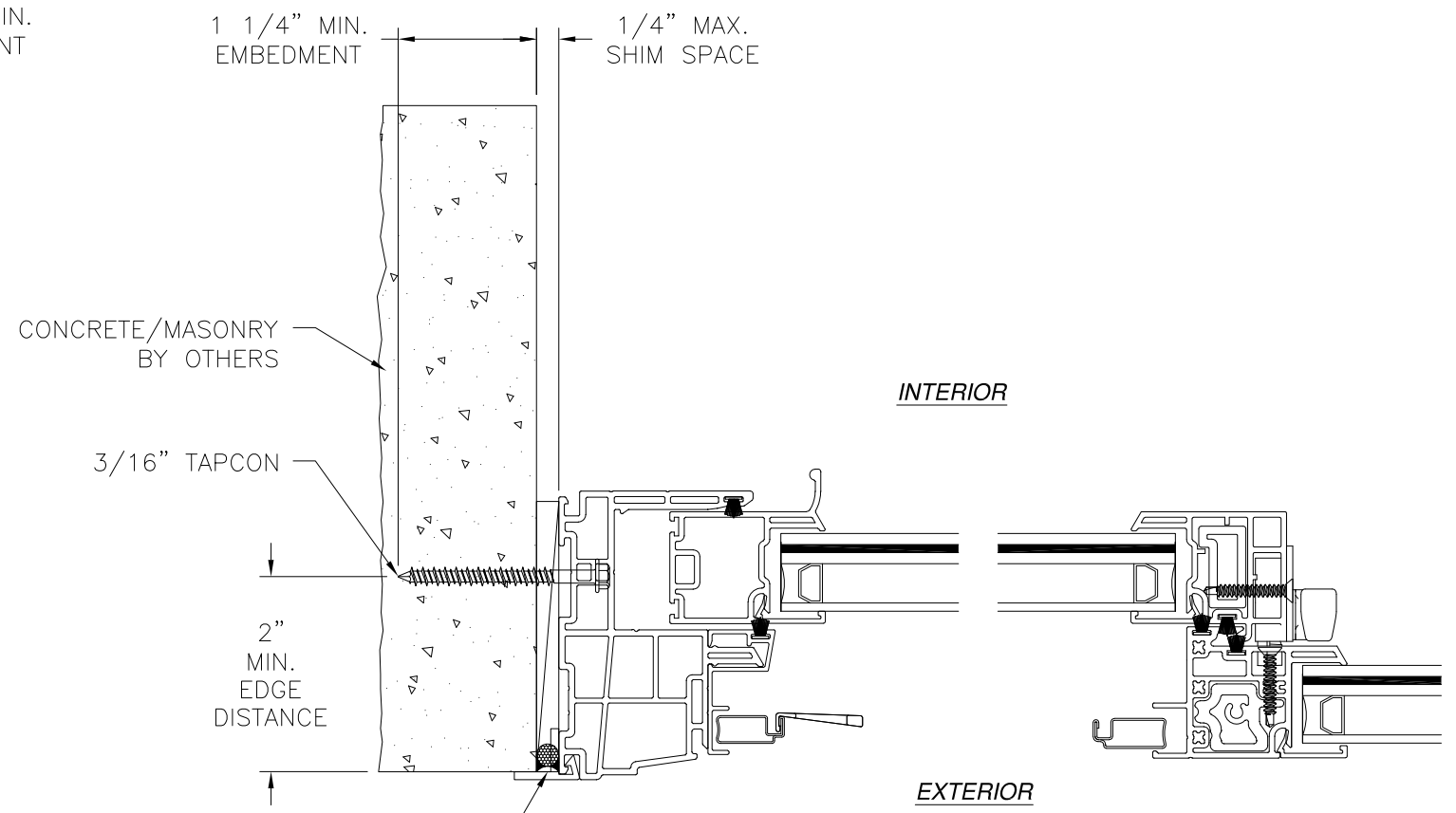

**JAMB INSTALLATION DETAIL**  
 CONCRETE/MASONRY WITHOUT 1X BUCK INSTALLATION  
 FOR CONCRETE/MASONRY WITH 1X BUCK REFER TO  
 HEAD AND SILL INSTALLATION DETAILS

- NOTES:**
1. INTERIOR AND EXTERIOR FINISHES, BY OTHERS, NOT SHOWN FOR CLARITY.
  2. PERIMETER AND JOINT SEALANT BY OTHERS TO BE DESIGNED IN ACCORDANCE WITH ASTM E2112

SIGNED: 10/26/2023

MI WINDOWS AND DOORS LLC  
 650 WEST MARKET STREET  
 GRATZ, PA 17030

SERIES 1630 HS REINFORCED  
 IMPACT 73" X 48"  
 FLANGE INSTALLATION DETAILS

DRAWN: A.R.	DWG NO. 08-03144	REV A
SCALE NTS	DATE 07/19/17	SHEET 8 OF 13

L. ROBERTO LOMAS P.E.  
 208 7th Ave, INDIALANTIC, FL 32903  
 434-688-0609 rllomas@lrlomaspe.com



Luis R. Lomas P.E.  
 FL No.: 62514



REVISIONS			
REV	DESCRIPTION	DATE	APPROVED
A	REVISED PER NEW CODE	10/26/2023	R.L.

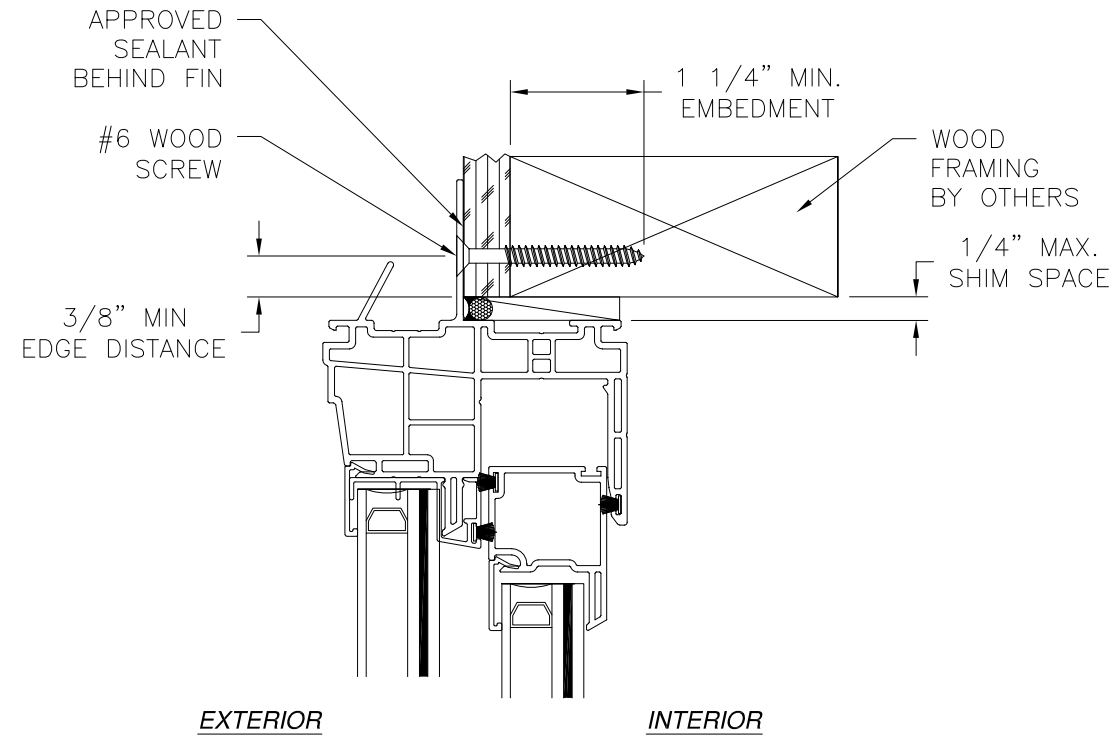

**VERTICAL CROSS SECTION**  
WOOD FRAMING OR 2X BUCK INSTALLATION

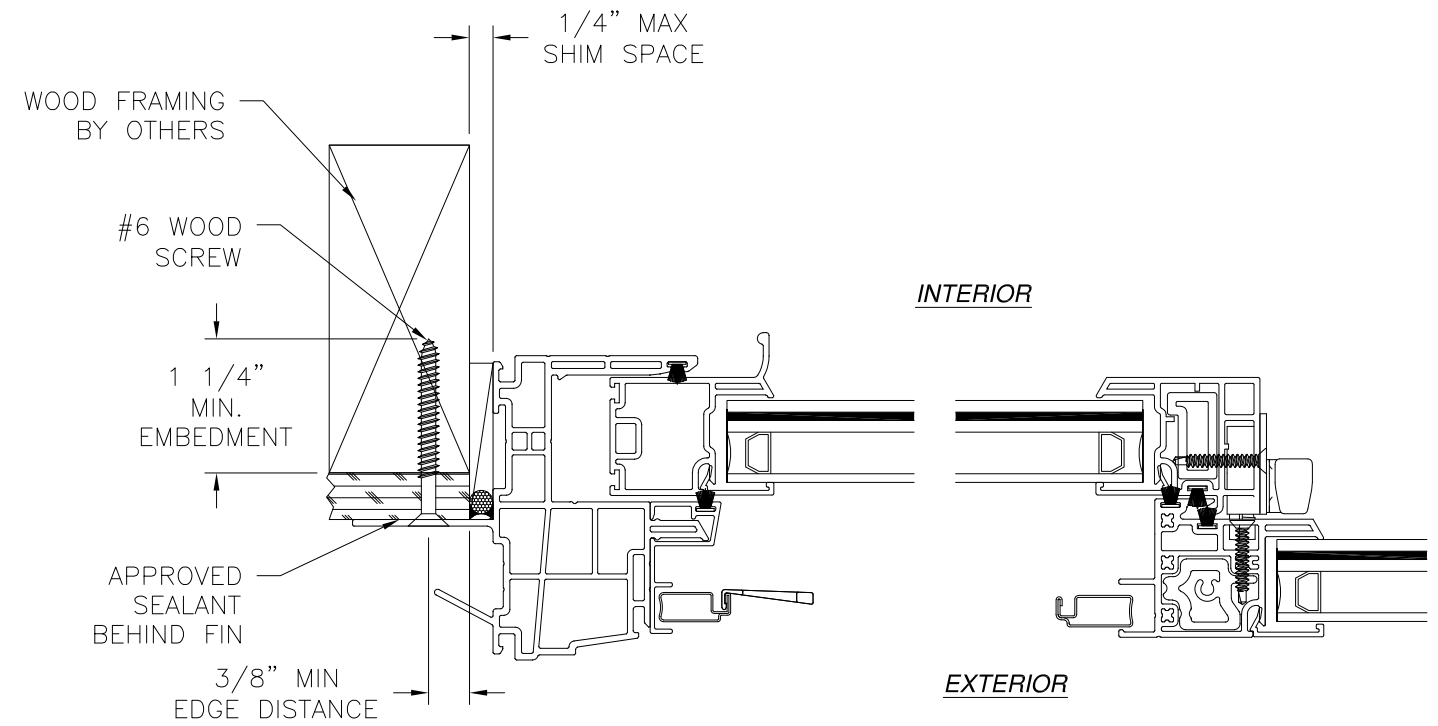
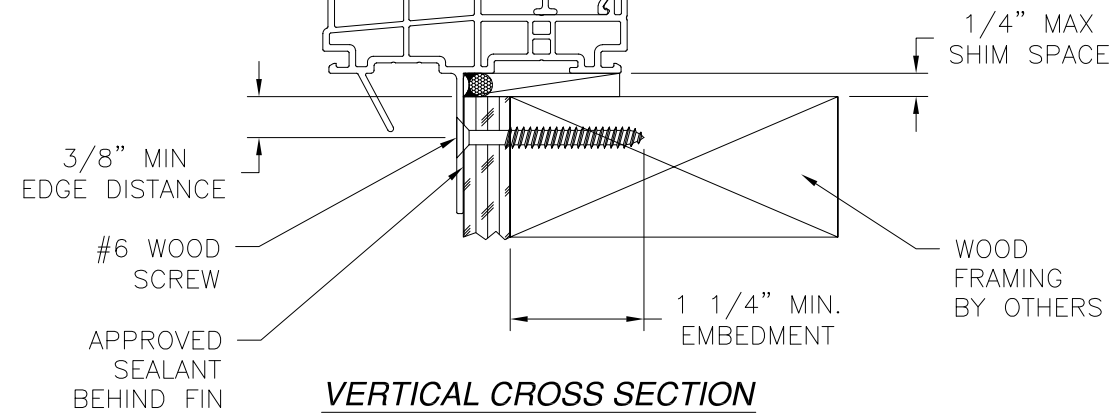

**JAMB INSTALLATION DETAIL**  
WOOD FRAMING OR 2X BUCK INSTALLATION

- NOTES:**
- INTERIOR AND EXTERIOR FINISHES, BY OTHERS, NOT SHOWN FOR CLARITY.
  - PERIMETER AND JOINT SEALANT BY OTHERS TO BE DESIGNED IN ACCORDANCE WITH ASTM E2112

MI WINDOWS AND DOORS LLC 650 WEST MARKET STREET GRATZ, PA 17030		
SERIES 1630 HS REINFORCED IMPACT 73" X 48" FIN WITH J CHANNEL INSTALLATION DETAILS		
DRAWN: A.R.	DWG NO. 08-03144	REV A
SCALE NTS	DATE 07/19/17	SHEET 9 OF 13
L. ROBERTO LOMAS P.E. 208 7th Ave, INDIALANTIC, FL 32903 434-688-0609 rllomas@lrlomaspe.com		

SIGNED: 10/26/2023

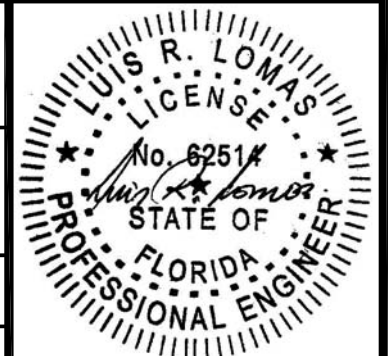

Luis R. Lomas P.E.  
FL No.: 62514

REVISIONS			
REV	DESCRIPTION	DATE	APPROVED
A	REVISED PER NEW CODE	10/26/2023	R.L.

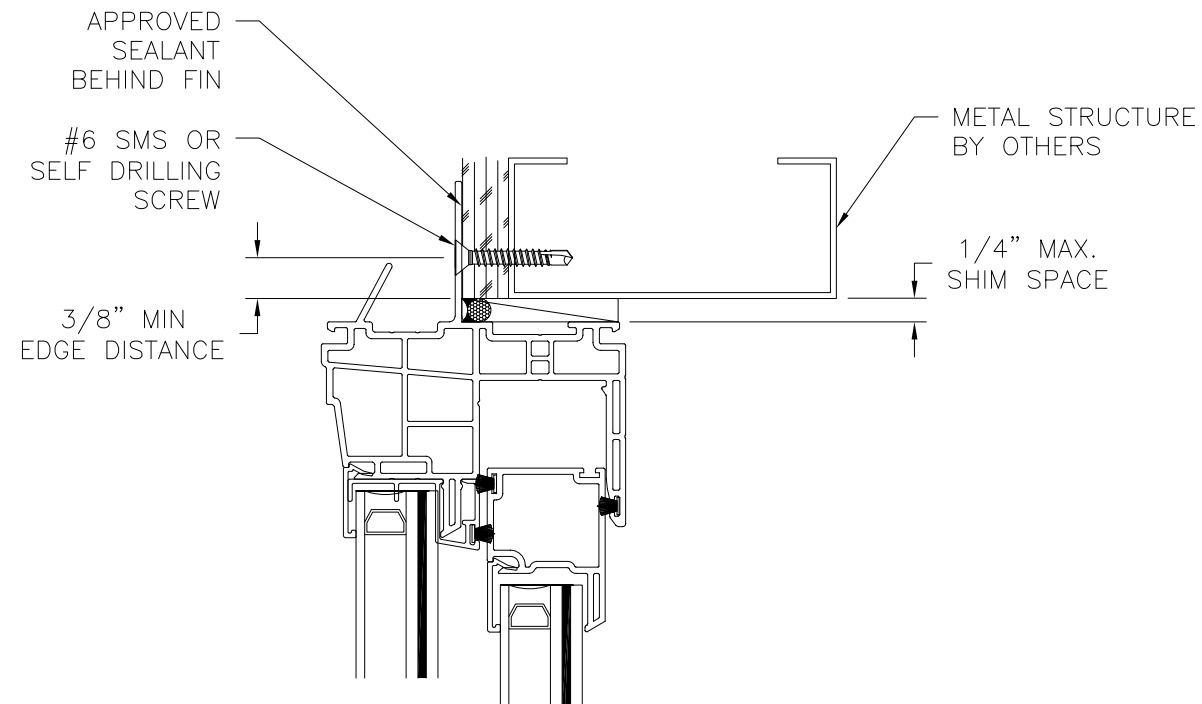

EXTERIOR

INTERIOR

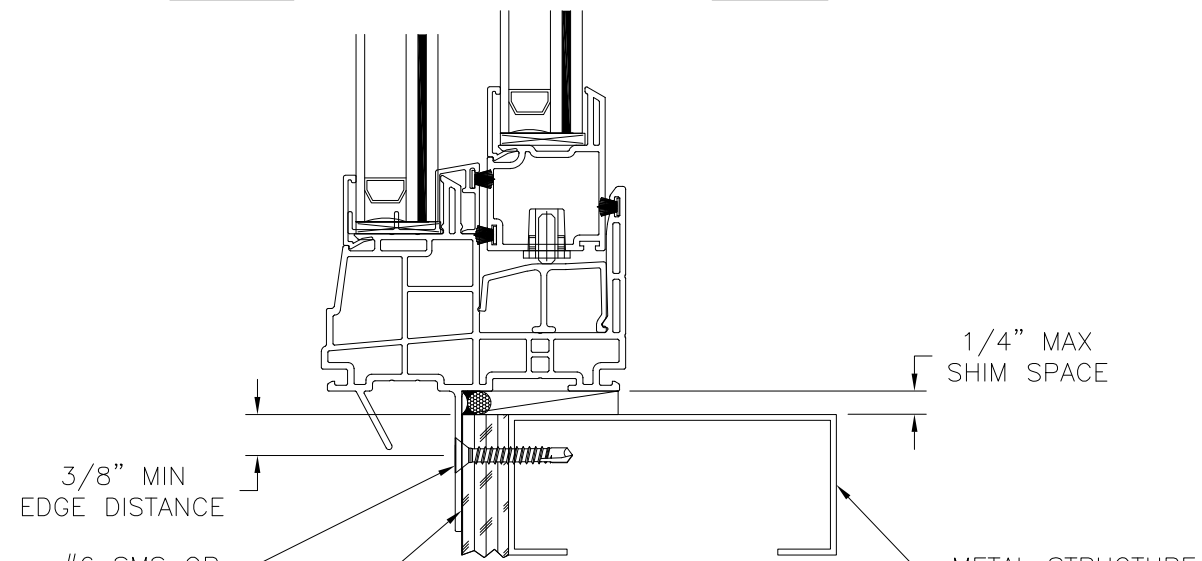

**VERTICAL CROSS SECTION**  
METAL STRUCTURE INSTALLATION

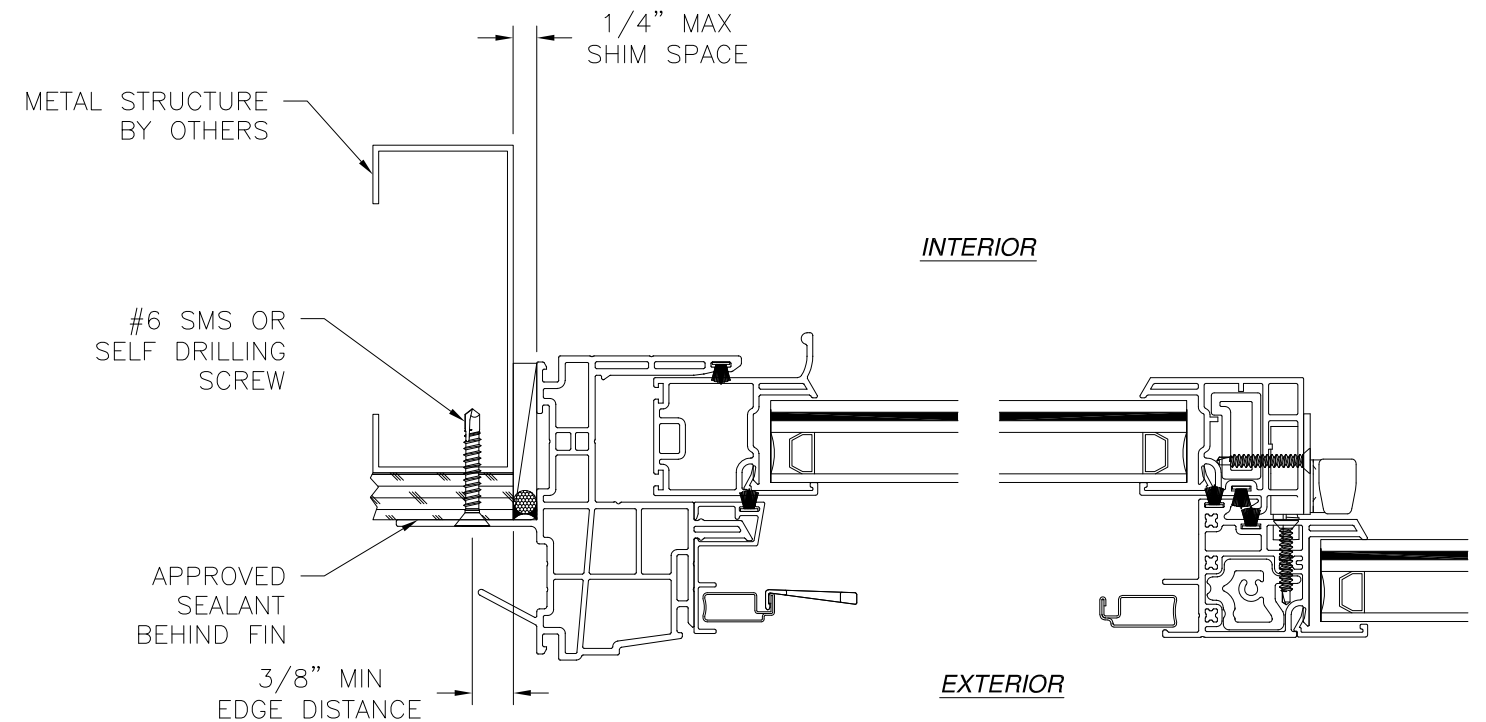

INTERIOR

EXTERIOR

**JAMB INSTALLATION DETAIL**  
METAL STRUCTURE INSTALLATION

**NOTES:**

1. INTERIOR AND EXTERIOR FINISHES, BY OTHERS, NOT SHOWN FOR CLARITY.
2. PERIMETER AND JOINT SEALANT BY OTHERS TO BE DESIGNED IN ACCORDANCE WITH ASTM E2112

SIGNED: 10/26/2023

MI WINDOWS AND DOORS LLC 650 WEST MARKET STREET GRATZ, PA 17030		
SERIES 1630 HS REINFORCED IMPACT 73" X 48" FIN WITH J CHANNEL INSTALLATION DETAILS		
DRAWN: A.R.	DWG NO. 08-03144	REV A
SCALE NTS	DATE 07/19/17	SHEET 10 OF 13
L. ROBERTO LOMAS P.E. 208 7th Ave, INDIALANTIC, FL 32903 434-688-0609 rllomas@rlomaspe.com		

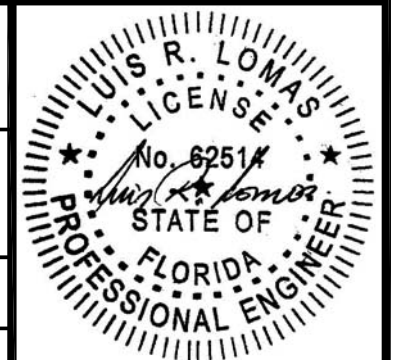

Luis R. Lomas P.E.  
FL No.: 62514

REVISIONS			
REV	DESCRIPTION	DATE	APPROVED
A	REVISED PER NEW CODE	10/26/2023	R.L.

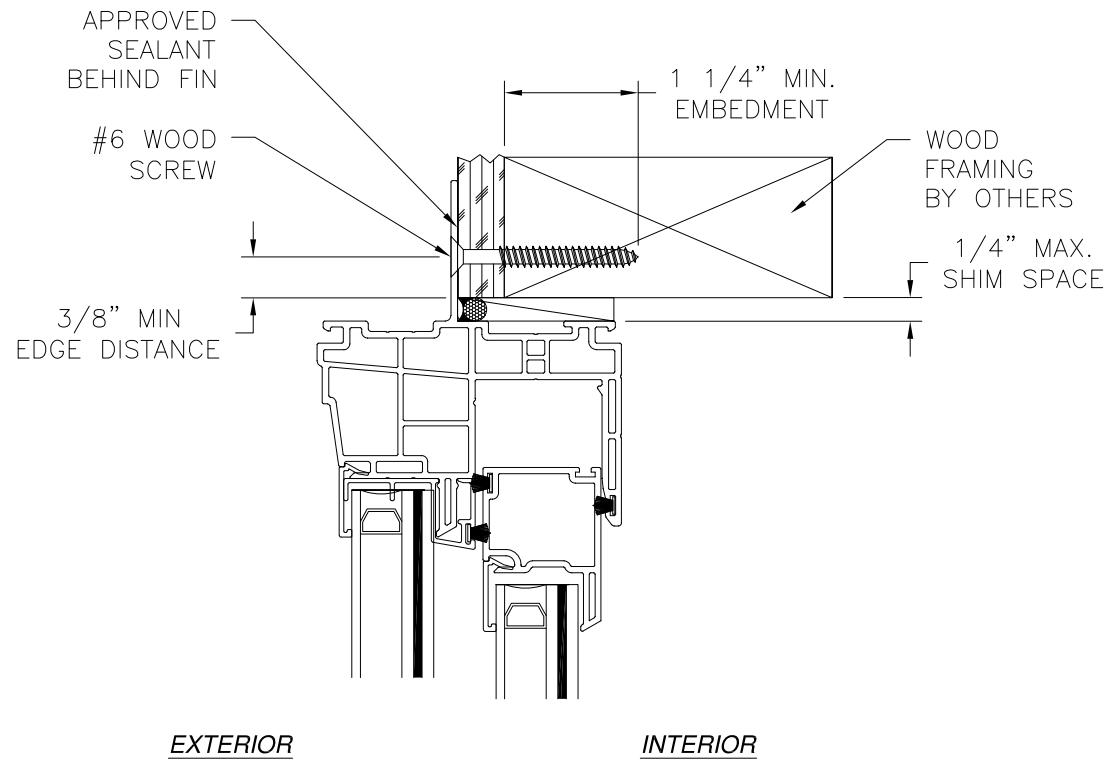

EXTERIOR INTERIOR

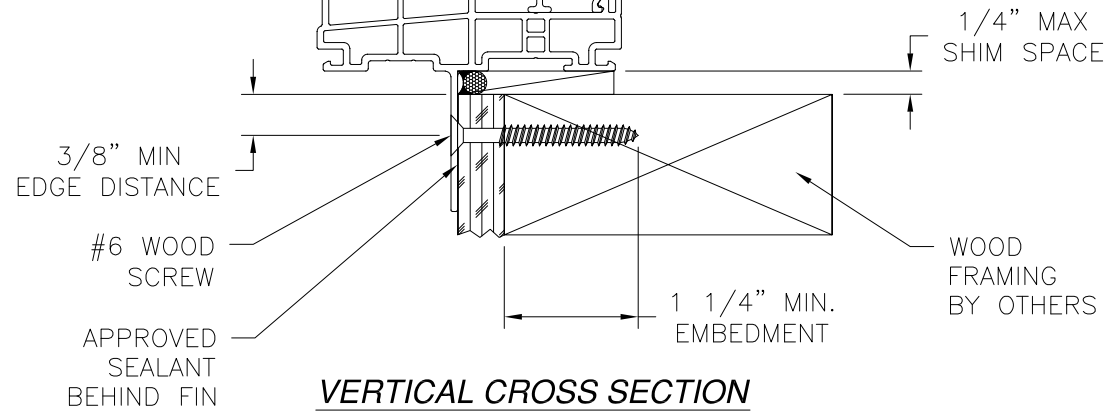

**VERTICAL CROSS SECTION**  
WOOD FRAMING OR 2X BUCK INSTALLATION

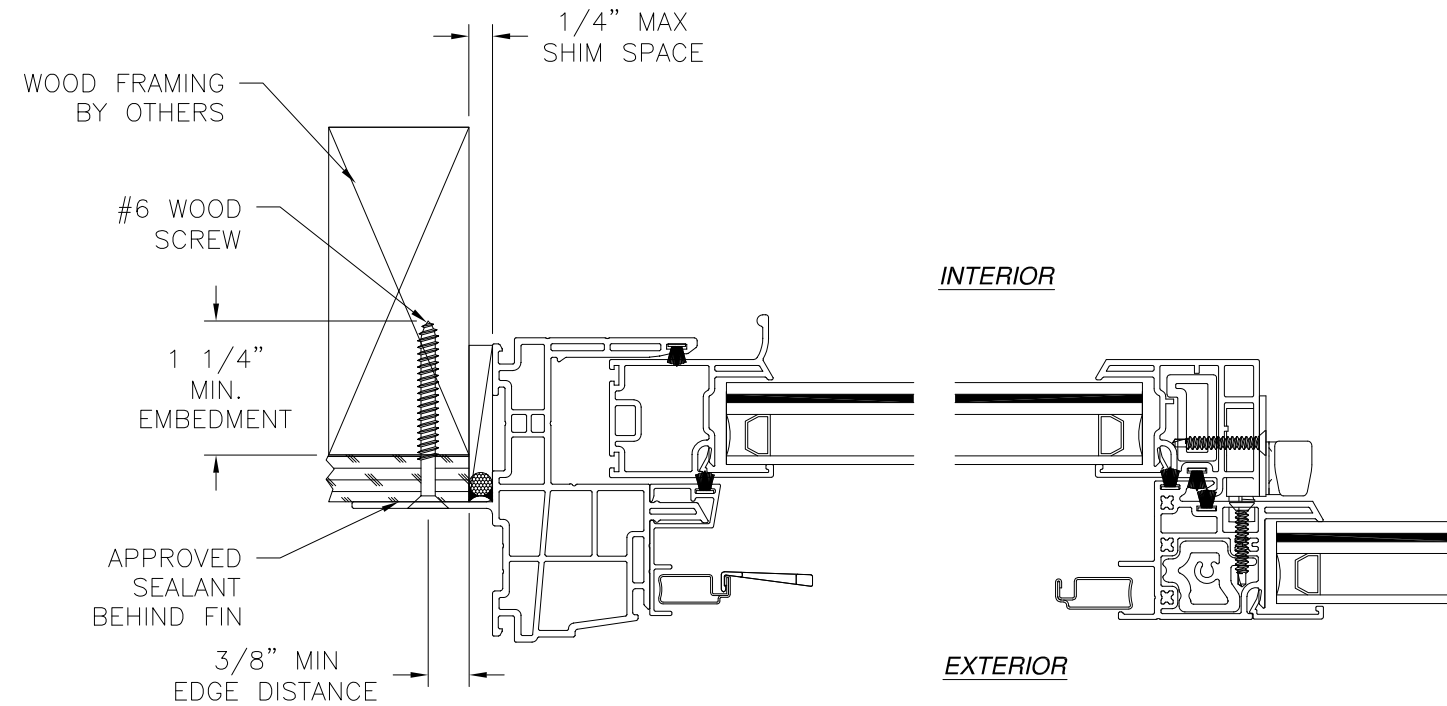

**JAMB INSTALLATION DETAIL**  
WOOD FRAMING OR 2X BUCK INSTALLATION

- NOTES:**
- INTERIOR AND EXTERIOR FINISHES, BY OTHERS, NOT SHOWN FOR CLARITY.
  - PERIMETER AND JOINT SEALANT BY OTHERS TO BE DESIGNED IN ACCORDANCE WITH ASTM E2112

MI WINDOWS AND DOORS LLC  
650 WEST MARKET STREET  
GRATZ, PA 17030

SERIES 1630 HS REINFORCED  
IMPACT 73" X 48"  
FIN INSTALLATION DETAILS

DRAWN: A.R.	DWG NO. 08-03144	REV A
SCALE NTS	DATE 07/19/17	SHEET 11 OF 13

L. ROBERTO LOMAS P.E.  
208 7th Ave, INDIALANTIC, FL 32903  
434-688-0609 rllomas@lrlomaspe.com

SIGNED: 10/26/2023

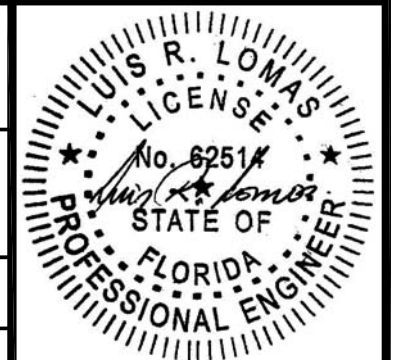

Luis R. Lomas P.E.  
FL No.: 62514

REVISIONS			
REV	DESCRIPTION	DATE	APPROVED
A	REVISED PER NEW CODE	10/26/2023	R.L.

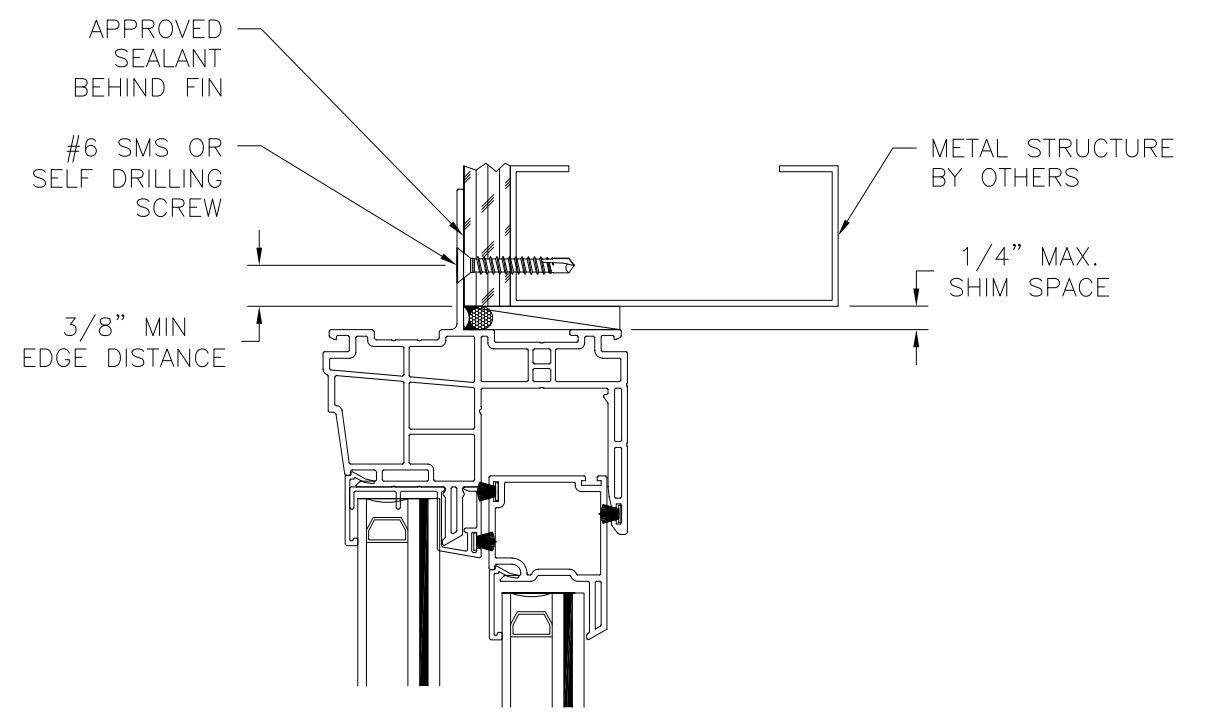

EXTERIOR INTERIOR

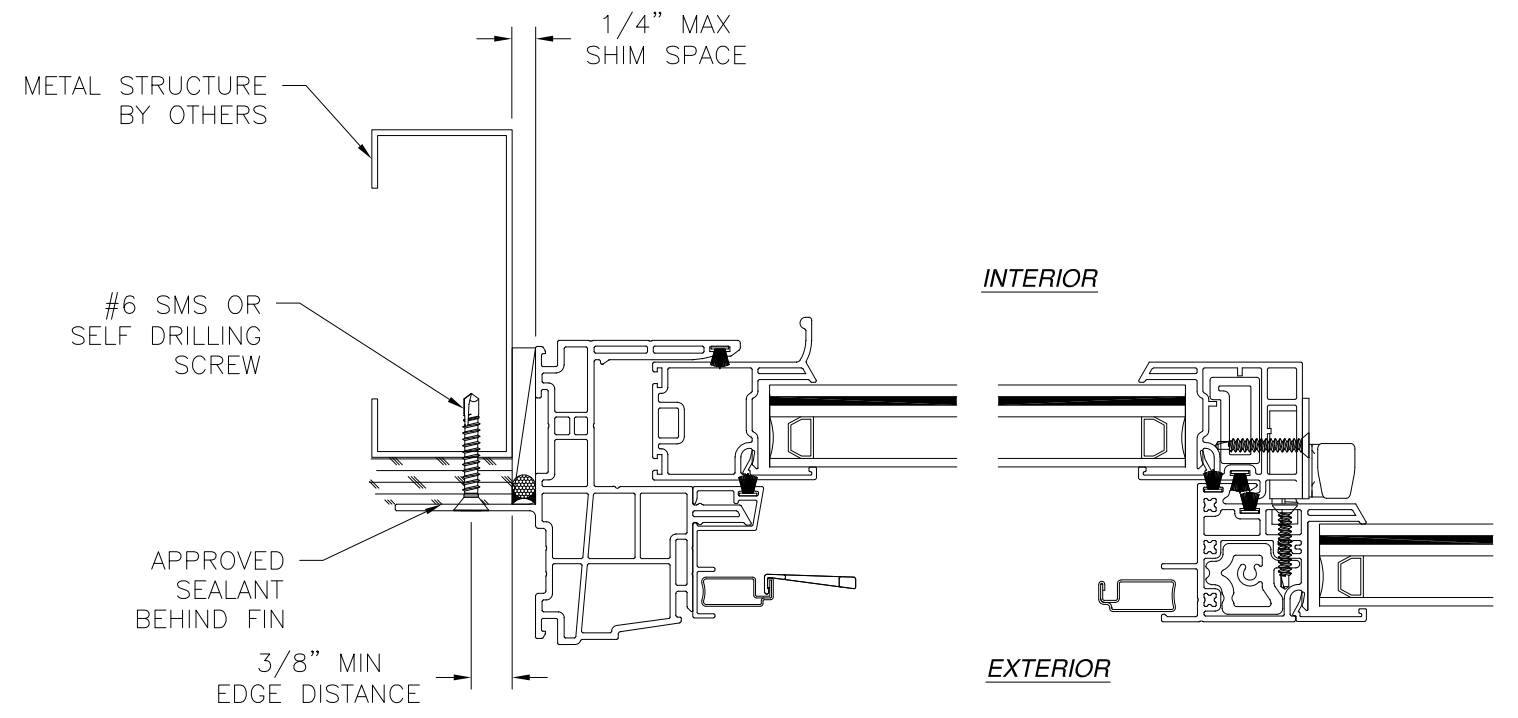

INTERIOR

EXTERIOR

**JAMB INSTALLATION DETAIL**  
METAL STRUCTURE INSTALLATION

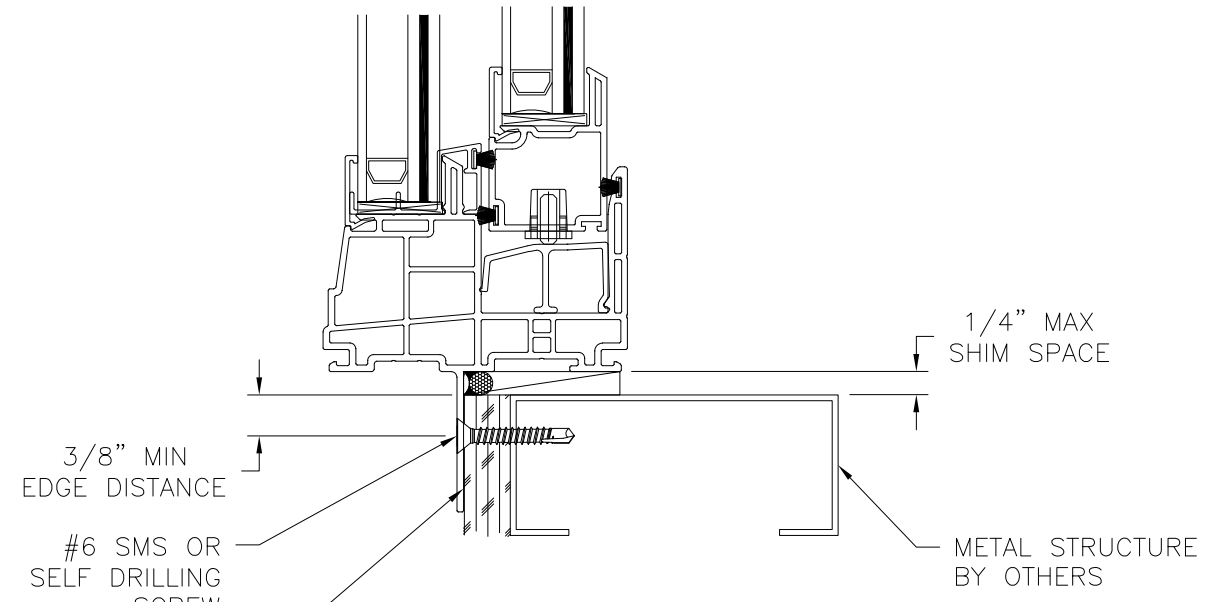

**VERTICAL CROSS SECTION**  
METAL STRUCTURE INSTALLATION

- NOTES:**
1. INTERIOR AND EXTERIOR FINISHES, BY OTHERS, NOT SHOWN FOR CLARITY.
  2. PERIMETER AND JOINT SEALANT BY OTHERS TO BE DESIGNED IN ACCORDANCE WITH ASTM E2112

SIGNED: 10/26/2023

MI WINDOWS AND DOORS LLC 650 WEST MARKET STREET GRATZ, PA 17030		
SERIES 1630 HS REINFORCED IMPACT 73" X 48" FIN INSTALLATION DETAILS		
DRAWN: A.R.	DWG NO. 08-03144	REV A
SCALE NTS	DATE 07/19/17	SHEET 12 OF 13
L. ROBERTO LOMAS P.E. 208 7th Ave, INDIALANTIC, FL 32903 434-688-0609 rllomas@lrlomaspe.com		

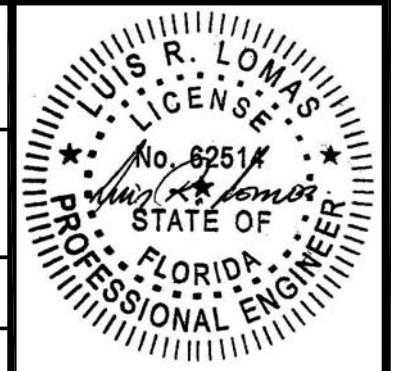

Luis R. Lomas P.E.  
FL No.: 62514

REVISIONS			
REV	DESCRIPTION	DATE	APPROVED
A	REVISED PER NEW CODE	10/26/2023	R.L.

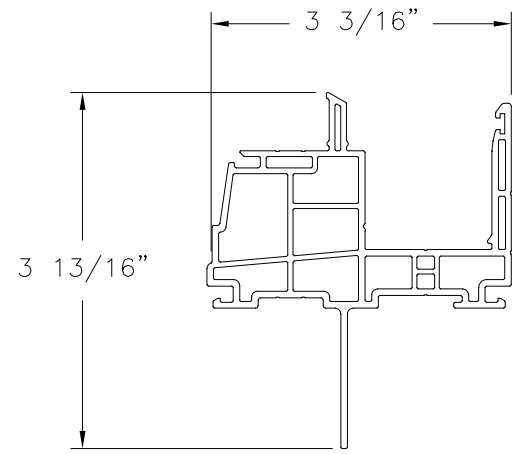

**MAIN FRAME FIN (V-1019)**  
RIGID VINYL PVC

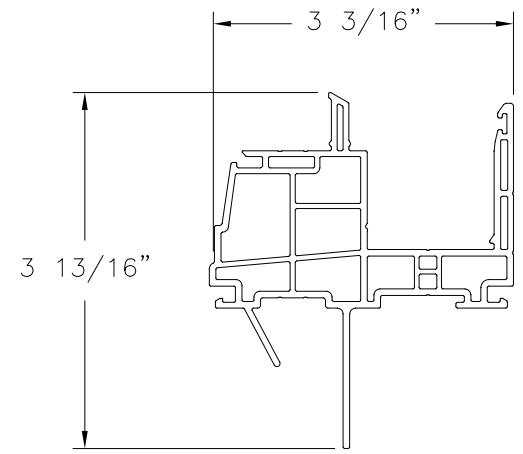

**MAIN FRAME FIN W/ J CHANNEL (V-1018)**  
RIGID VINYL PVC

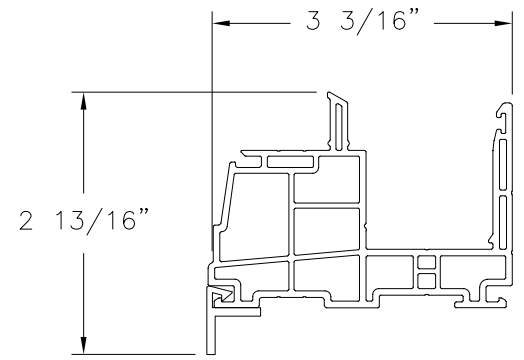

**MAIN FRAME FINLESS FLANGE (V-1022)**  
RIGID VINYL PVC

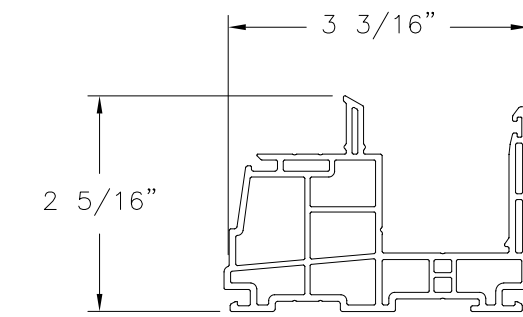

**MAIN FRAME FINLESS (V-1020)**  
RIGID VINYL PVC

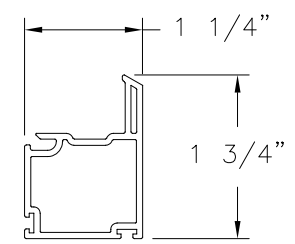

**SASH, HORIZONTAL RAIL (V-670)**  
RIGID VINYL PVC

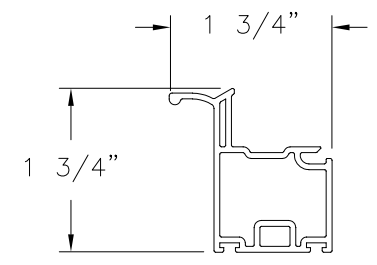

**SASH, PULL RAIL (V-672)**  
RIGID VINYL PVC

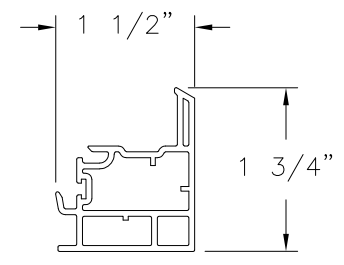

**SASH, LOCK RAIL (V-675)**  
RIGID VINYL PVC

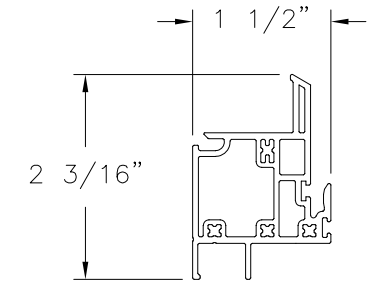

**FIXED MEETING RAIL (V-1016)**  
RIGID VINYL PVC

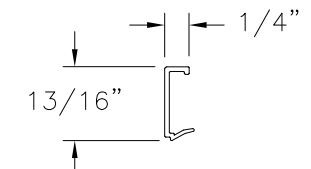

**GLAZING BEAD (V-904)**  
RIGID VINYL PVC

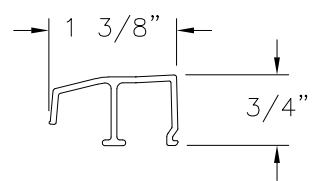

**SINGLE SLIDE ROLLER TRACK (M-2345)**  
ALUMINUM 6063-T5

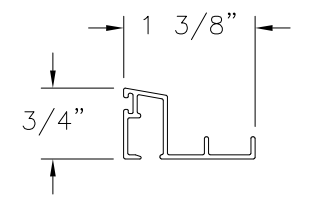

**OPERABLE SCREEN TRACK (M-2340)**  
ALUMINUM 6063-T5

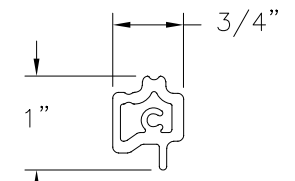

**MEETING RAIL REINFORCEMENT (M-2343)**  
ALUMINUM 6063-T5

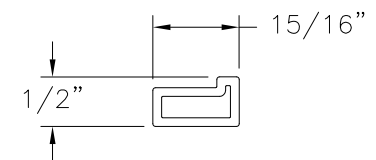

**LOCK RAIL REINFORCEMENT (M-2115)**  
ALUMINUM 6063-T5

MI WINDOWS AND DOORS LLC  
650 WEST MARKET STREET  
GRATZ, PA 17030

SERIES 1630 HS REINFORCED  
IMPACT 73" X 48"  
COMPONENTS

DRAWN: A.R.	DWG NO. 08-03144	REV A
SCALE NTS	DATE 07/19/17	SHEET 13 OF 13

L. ROBERTO LOMAS P.E.  
208 7th Ave, INDIALANTIC, FL 32903  
434-688-0609 rllomas@rlomaspe.com

SIGNED: 10/26/2023

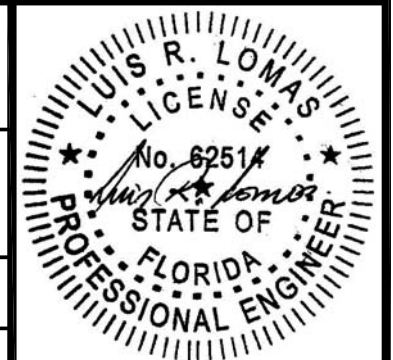

Luis R. Lomas P.E.  
FL No.: 62514